

0.180" 4-Character 5x7 Dot Matrix Serial Input Dot Addressable Intelligent Display® Devices

Lead (Pb) Free Product / RoHS Compliant



SCE574x



SCE574xP-SIP

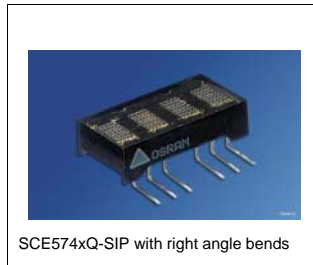

SCE574xQ-SIP with right angle bends

Standard Red SCE5740
Green SCE5743

Yellow SCE5741
High Efficiency Green SCE5744

Super-red SCE5742
Orange SCE5745

DESCRIPTION

The SCE574x is a four digit, dot addressable 5 x 7 dot matrix, serial input, alphanumeric Intelligent Display device. The four digits are packaged in a rugged, high quality, optically transparent, plastic 14 pin DIP with 2.54 mm (0.1") pin spacing.

The SCE574xP is a SIP version of SCE574x. The SCE574xQ is also a SIP version of the SCE574x but the leads are at right angles to the package so that the part can be mounted vertically. The SIP version parts have only 7 pins. The SIP parts do not have the option of using an external clock. All the electrical descriptions for the SCE574x apply to the SIP versions except the allusions to the external clock.

The on-Board CMOS has a 140 bit RAM, one bit associated with one LED, each to generate User Defined Characters. In Power Down Mode, quiescent current is < 50 µA.

The SCE574x is designed to work with the serial port of most common microprocessors. Data is transferred into the display through the Serial Data Input (DATA), clocked by the Serial Data Clock (SDCLK), and enabled by the Load Input (LOAD).

The SCE574x Clock I/O (Clk I/O) and Clock Select (CLK-SEL) pins offer the user the capability to supply a high speed external multiplex clock. This feature can minimize audio in-band interference for portable communication equipment or eliminate the visual synchronization effects found in high vibration environments such as avionic equipment.

A divide by 16 prescaler is built into the part and can be accessed by software to reduce the multiplex frequency if a high speed external clock is used.

ALSO AVAILABLE WITH OPTIONS

(see [page 8](#))

- SCE574xP-SIP
- SCE574xQ-SIP with right angle bends

FEATURES

- Four 4.57 mm (0.180") 5 x 7 Dot Matrix Characters in Red, Yellow, Super-red, Green, High Efficiency Green, Orange
- Optimum Display Surface Efficiency (display area to package ratio)
- High Speed Data Input Rate: 5.0 MHz
- ROMless Serial Input, Dot Addressable Display Ideal for User Defined Characters
- Built-in Decoders, Multiplexers and LED Drivers
- Wide Viewing Angle, X Axis ± 55°, Y Axis ± 55°

ATTRIBUTES

- 140 Bit RAM for User Defined Characters
- Eight Dimming Levels plus eight fine dimming levels.
- Power Down Model (< 250 mW)
- Hardware/Software Clear Functions
- External Clock-SCE574x only

Ordering Information

Type	Color of Emission	Character Height mm (inch)	Ordering Code
SCE5740	standard red	4.57 (0.180)	Q68100A1369
SCE5741	yellow		Q68100A1370
SCE5742	super-red		Q68100A1371
SCE5743	green		Q68100A1372
SCE5744	high efficiency green		Q68100A1373
SCE5745	orange		Q68100A1374

Package Outlines

Dimensions in mm (inch)

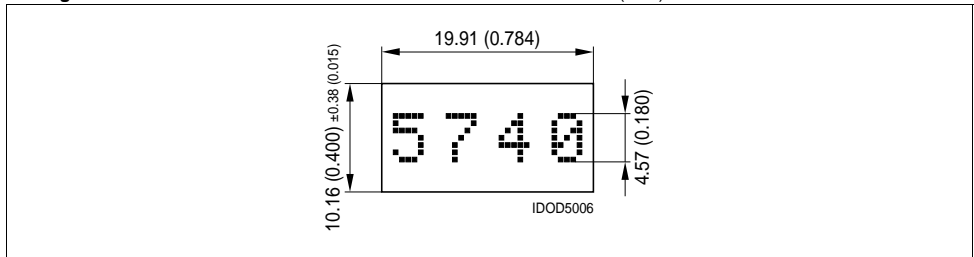

Maximum Ratings

Parameter	Symbol	Value	Unit
Operating temperature range	T_{op}	- 40 ... + 85	°C
Storage temperature range	T_{stg}	- 40 ... + 100	°C
DC Supply Voltage	V_{CC}	-0.5 to + 7.0	V
Input Voltage Levels Relative to GND		-0.5 to $V_{CC} + 0.5$	V
Solder Temperature 1.59 mm (0.063") below seating plane, $t < 5.0$ s	T_s	260	°C
Relative Humidity		85	%
ESD (100 pF, 1.5 kΩ)	V_Z	2.0	kV
Input Current		130	mA
Maximum Number of LEDs on at 100% Brightness		64	
Maximum Power Dissipation		0.6	W

Optical Characteristics at 25°C

($V_{CC}=5.0$ V at 100% brightness level, viewing angle: X axis $\pm 55^\circ$, Y axis $\pm 65^\circ$)

Description	Symbol	Values						Unit
		Red SCE5740	Yellow SCE5741	Super-red SCE5742	Green SCE5743	High Efficiency Green SCE5744	Orange SCE5745	
Luminous Intensity (min.) (typ.)	I_v	30 60	60 150	60 150	60 150	80 180	60 150	$\mu\text{cd}/\text{dot}$ $\mu\text{cd}/\text{dot}$
Peak Wavelength (typ.)	λ_{peak}	655	583	630	565	568	605	nm
Dominant Wavelength (typ.)	λ_{dom}	639	585	620	573	574	610	nm

Notes:

1. Dot to dot intensity matching at 100% brightness is 1.8:1.
2. Displays within a given intensity category have an intensity matching of 1.5:1 (max.).

Electrical Characteristics (over operating temperature)

Parameter	Min.	Typ.	Max.	Units	Conditions
V_{CC}	4.5	5.0	5.5	V	—
I_{CC} (Power Down) ^{1) 2)}	—	—	50	μ A	$V_{CC}=5.0$ V, all inputs=0 V or V_{CC}
I_{CC} 4 digits 20 dots/character ³⁾	90	115	130	mA	$V_{CC}=5.0$ V, “#” displayed in all 4 digits at 100% brightness at 25°C
I_{IL} Input current	—	—	-10	μ A	$V_{CC}=5.0$ V, $V_{IN}=0$ (all inputs)
I_{IH} Input current	—	—	10	μ A	$V_{CC}=V_{IN}=5.0$ V (all inputs)
V_{IH}	3.5	—	—	V	$V_{CC}=4.5$ V to 5.5 V
V_{IL}	—	—	1.5	V	$V_{CC}=4.5$ V to 5.5 V
Row Multiplex Rate	375	768	1086	Hz	—
θ_{JC-pin}	—	—	45	$^{\circ}$ C/W	—

Notes:

- 1) Unused inputs must be tied high.
- 2) External oscillator must be stopped.
- 3) Peak current $\frac{5}{3} \times I_{CC}$.

Electrical Characteristics for SCE574x only

Parameter	Min.	Typ.	Max.	Units	Conditions
I_{OH} (CLK I/O)	—	-28	—	mA	$V_{CC}=4.5$ V, $V_{OH}=2.4$ V
I_{OL} (CLK I/O)	—	23	—	mA	$V_{CC}=4.5$ V, $V_{OL}=0.4$ V
F_{ext} External Clock Input Frequency	120	—	3	MHz	$V_{CC}=5.0$ V, $CLKSEL=0$
F_{osc} Internal Clock Input Frequency	120	—	347	kHz	$V_{CC}=5.0$ V, $CLKSEL=1$
Clock I/O Bus Loading	—	—	240	pF	—
Clock Out Rise Time	—	—	500	ns	$V_{CC}=4.5$ V, $V_{OH}=2.4$ V
Clock Out Fall Time	—	—	500	ns	$V_{CC}=4.5$ V, $V_{OH}=0.4$ V

Input/Output Circuits

Figures „Inputs“ and „Clock I/O“ show the input and output resistor/diode networks used for ESD protection and to eliminate substrate latch-up caused by input voltage over/under shoot.

Inputs

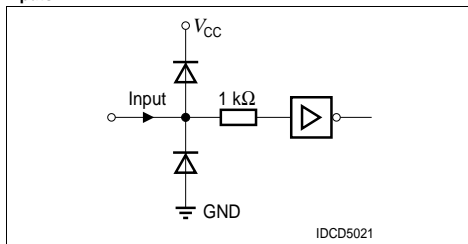

Clock I/O (SCE574X only)

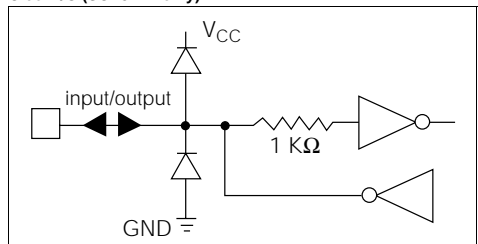

Switching Specifications

(over operating temperature range and $V_{CC}=4.5\text{ V to }5.5\text{ V}$)

Symbol	Description	Min.	Units
T_{RC}	Reset Active Time	600	ns
T_{LDS}	Load Setup Time	50	ns
T_{DS}	Data Setup Time	50	ns
T_{SDCLK}	Clock Period	200	ns
T_{BL}	Time Between Loads	600	ns

Symbol	Description	Min.	Units
T_{SDCW}	Clock Width	70	ns
T_{LDH}	Load Hold Time	0	ns
T_{DH}	Data Hold Time	25	ns
T_{WR}	Total Write Time	2.2	μs

Note:

T_{SDCW} is the minimum time the SDCLK may be low or high.
The SDCLK period must be a minimum of 200 ns.

Timing Diagram—Data Write Cycle

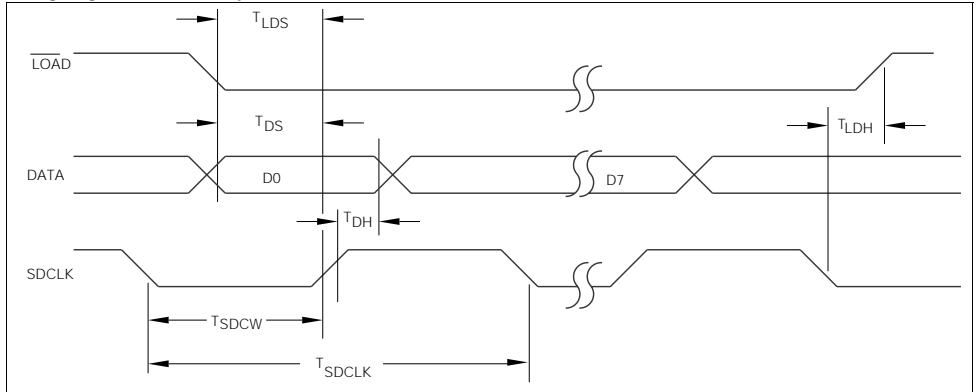

Timing Diagram—Instruction Cycle

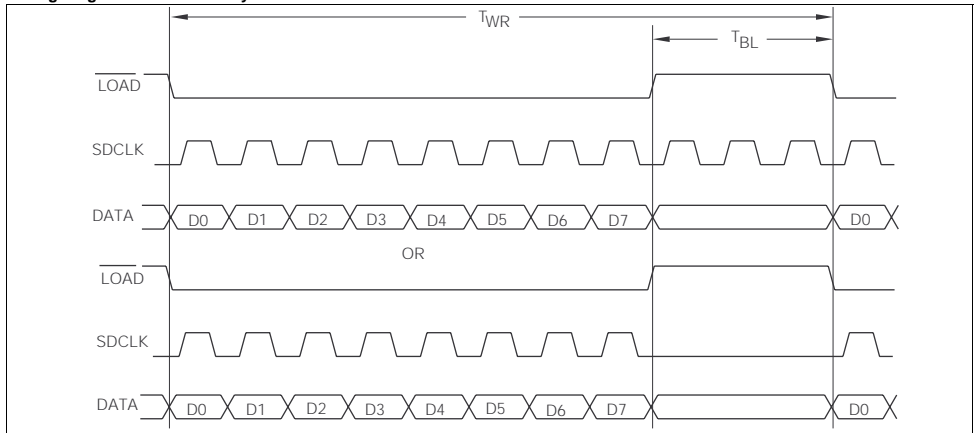

Top View

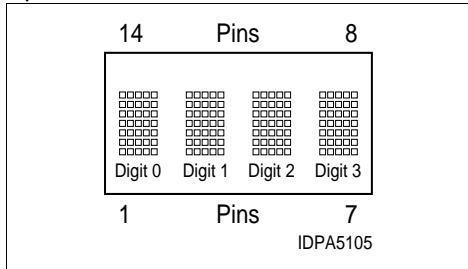

Pin Assignment

Pin	Function	Pin	Function
1	V _{CC}	14	CLK SELECT
2	LOAD	13	no pin
3	DATA	12	no pin
4	no connection	11	no pin
5	SDCLK	10	no pin
6	RST	9	no pin
7	GND	8	CLK I/O

Dot Matrix Format

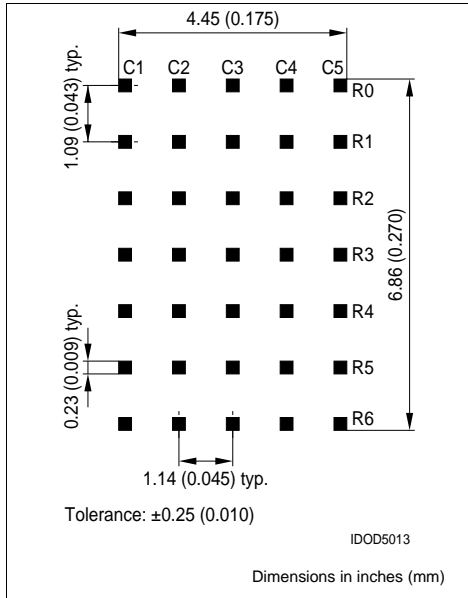

Pin Definitions

Pin	Function	Definitions
1	V _{CC}	Power supply
2	LOAD	Low input enables data clocking into 8-bit serial shift register. When LOAD goes high, the contents of 8-bit serial Shift Register will be decoded.
3	DATA	Serial data input
4	N/C	no connection
5	SDCLK	for loading data into the 8-bit serial data register
6	RST	Asynchronous input, when low clears the Multiplex Counter, Control Word Register, User RAM and Data Register. Control Word Register is set to 100% brightness. The display will be blank.
7	GND	Supply ground
8	CLK I/O	Outputs master clock or inputs external clock.
9	N/P	No pins
10	N/P	No pins
11	N/P	No pins
12	N/P	No pins
13	N/P	No pins
14	CLKSEL	H=internal clock, L=external clock

Display Column and Row Format

	C0	C1	C2	C3	C4
Row 0	1	1	1	1	1
Row 1	0	0	1	0	0
Row 2	0	0	1	0	0
Row 3	0	0	1	0	0
Row 4	0	0	1	0	0
Row 5	0	0	1	0	0
Row 6	0	0	1	0	0

1= Display dot „ON“
0=Display dot „OFF“

Column Data Ranges

Row 0	00H to 1FH	Row 4	00H to LFH
Row 1	00H to LFH	Row 5	00H to LFH
Row 2	00H to LFH	Row 6	00H to LFH
Row 3	00H to LFH		

Block Diagram

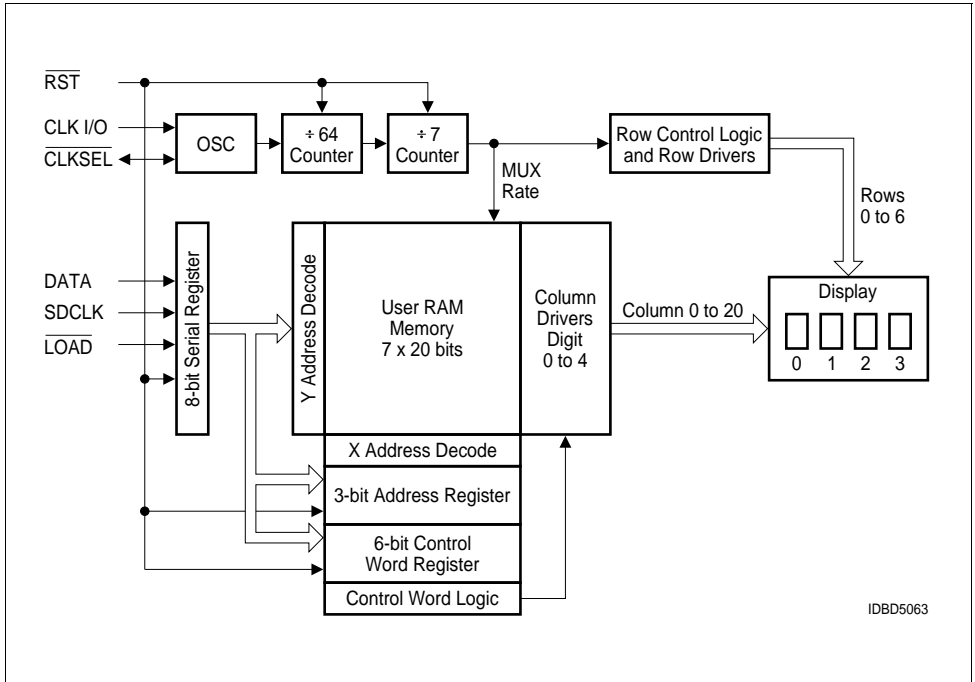

Operation of the SCE574x

The SCE574x display consists of a CMOS IC containing control logic and drivers for four 5 x 7 characters. These components are assembled in a compact plastic package.

Individual LED dot addressability allows the user great freedom in creating special characters or mini-icons.

The serial data interface provides a highly efficient interconnection between the display and the mother board. The SCE574x requires only three lines as compared to 14 lines for an equivalent four character parallel input part.

The on-board CMOS IC is the electronic heart of the display. The IC accepts decoded serial data, which is stored in the internal RAM. Asynchronously the RAM is read by the character multiplexer at a strobe rate that results in a flicker free display. Figure „Block Diagram“ (page 7) shows the three functional areas of the IC. These include: the input serial data register and control logic, a 140 bits two port RAM, and an internal multiplexer/display driver.

The following explains how to format the serial data to be loaded into the display. The user supplies a string of bit mapped decoded characters. The contents of this string is shown in Figure „Loading Serial Character Data a“ (page 8). Figure „Loading Serial Character Data b“ (page 8) shows that each character consist of eight 8 bit words. The first word encodes the display character location and the succeeding five bytes are row data. The row data represents the status (On, Off) of individual column LEDs. Figure „Loading Serial Character Data c“ (page 8) shows that each 8 bit word is formatted to represent Column Data or Character Address.

Figure „Loading Serial Character Data d“ (page 8) shows the sequence for loading the bytes of data. Bringing the LOAD line low enables the serial register to accept data. The shift action occurs on the low to high transition of the serial data clock (SDCLK). The least significant bit (D0) is loaded first. After eight clock pulses the LOAD line is brought high. With this transition the OPCODE is decoded. The decoded OPCODE directs D4-D0 to be latched in the Character Address register, stored in the RAM as Column data, or latched in the Control Word register. The control IC requires a minimum 600 ns delay between successive byte loads.

Loading Serial Character Data

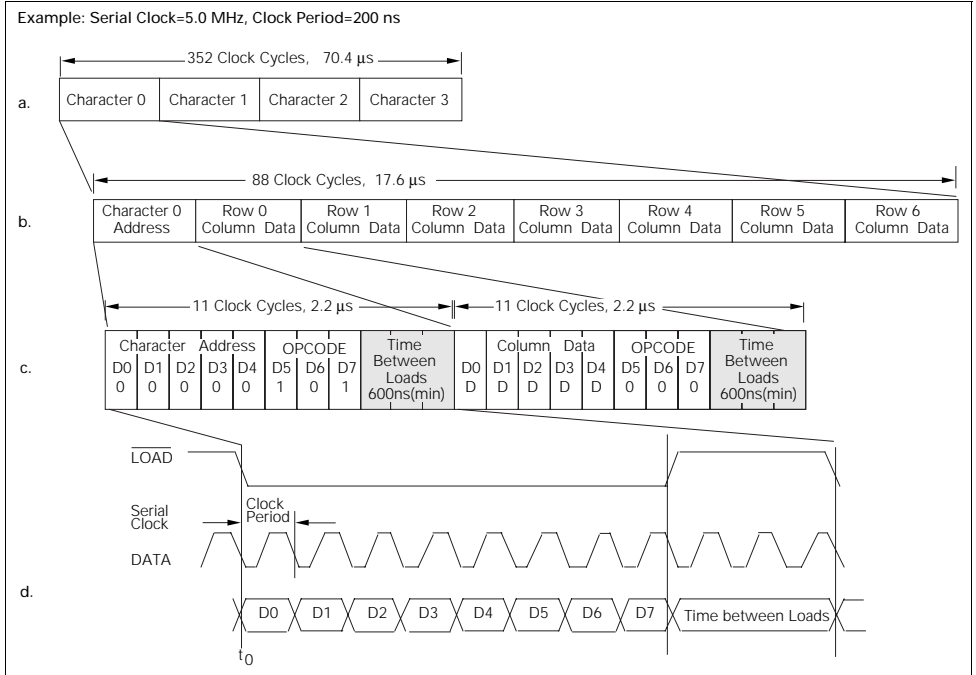
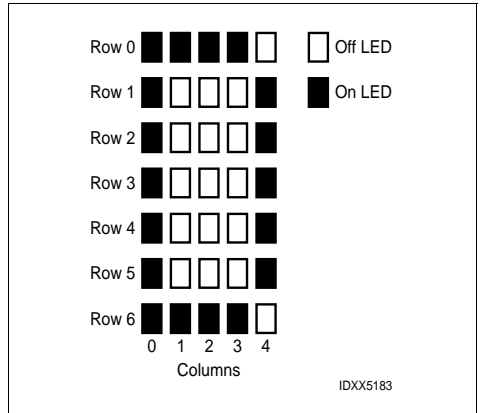

Table „Character D” (page 8) shows the Row Address for the example character “D.” Column data is written and read asynchronously from the 140 bit RAM. Once loaded the internal oscillator and character multiplexer reads the data from the RAM. These characters are row strobed with column data as shown in Figures „Row and Columns Locations for a Character ‘D’” (page 8) and „Row Strobing” (page 9). The character strobe rate is determined by the internal or user supplied external MUX Clock, the IC’s counter and the prescaler.

Row and Column Locations for a Character “D”



Character “D”

	Op code			Column Data				Hex	
	D7	D6	D5	D4 C0	D3 C1	D2 C2	D1 C3		D0 C4
Row 0	0	0	0	1	1	1	1	0	1E
Row 1	0	0	0	1	0	0	0	1	11
Row 2	0	0	0	1	0	0	0	1	11
Row 3	0	0	0	1	0	0	0	1	11
Row 4	0	0	0	1	0	0	0	1	11
Row 5	0	0	0	1	0	0	0	1	11
Row 6	0	0	0	1	1	1	1	0	1E

Row Strobing

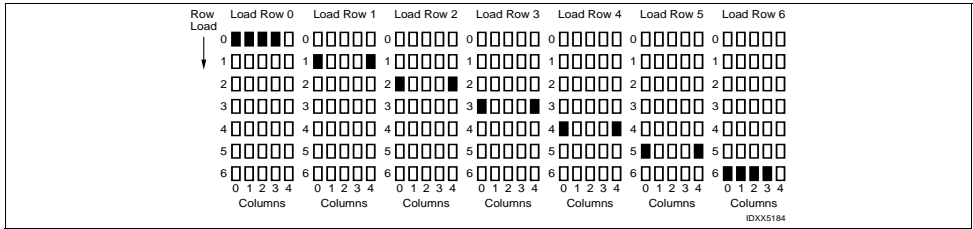

Multiplexer and Display Driver

The four characters are row multiplexed with RAM resident column data. The strobe rate is established by the internal or external MUX Clock rate. The MUX Clock frequency is divided by a 448 counter chain. This results in a typical strobe rate of 768 Hz. By pulling the Clock SEL line low, the display can be operated from an external MUX Clock. The external clock is attached to the CLK I/O connection (pin 8). The maximum external MUX Clock frequency should be limited to 3 MHz.

When a high speed external clock is used the frequency can be further divided down by 16 by using the built in prescaler. In the control word format data bit D4 is set high (D4=1). It is not recom-

mended to use the prescaler with the internal clock.

An asynchronous hardware Reset (pin 6) is also provided. Bringing this pin low will clear the Character Address Register, Control Word Register, RAM, and blanks the display. This action leaves the display set at Character Address 0, and the Brightness Level set at 100%.

The user can activate four Control functions. These include: LED Brightness Level, IC Power Down, Prescaler, or Display Clear. OPCODEs and six bit words are used to initiate these functions. The OPCODEs and Control Words for the Character Address and Loading Column Data are shown in Tables „Load Character Address“ (page 10) and „Load Column Data“ (page 10).

Basic Instruction Set

Instruction	Opcode	Address/Data	Comments
LCD	000	D4 D3 D2 D1 D0	Load Column Data
LDA	101	X X A2 A1 A0	Load Digit Address
SCL	110	PS B3 B2 B1 B0	Software Clear
LCWD	111	PS B3 B2 B1 B0	Load Control Word Data

Control Word Format

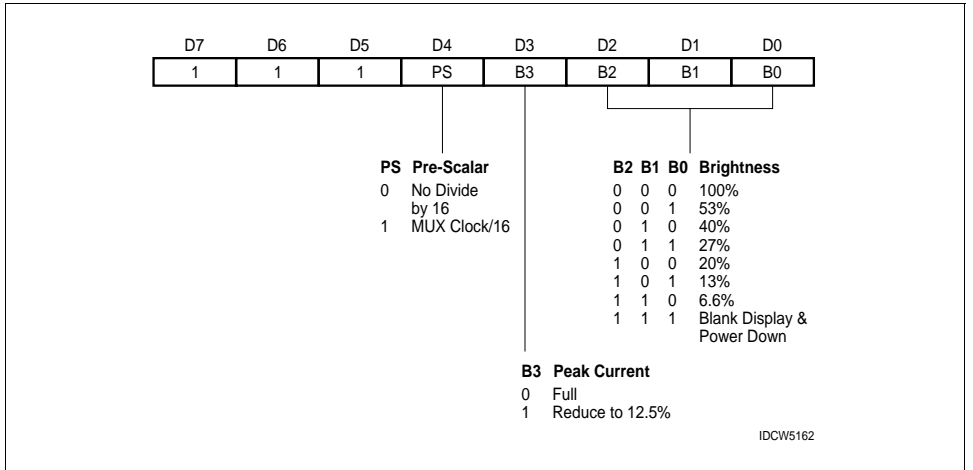

Load Character Address

Op code D7 D6 D5	Character Address D4 D3 D2 D1 D0	Hex	Operation Load
1 0 1	0 0 0 0 0	A0	Character 0
1 0 1	0 0 0 0 1	A1	Character 1
1 0 1	0 0 0 1 0	A2	Character 2
1 0 1	0 0 0 1 1	A3	Character 3

Load Column Data

Op code D7 D6 D5	Column Data D4 D3 D2 D1 D0	Operation Load
0 0 0	C0 C1 C2 C3 C4	Row 0
0 0 0	C0 C1 C2 C3 C4	Row 1
0 0 0	C0 C1 C2 C3 C4	Row 2
0 0 0	C0 C1 C2 C3 C4	Row 3
0 0 0	C0 C1 C2 C3 C4	Row 4
0 0 0	C0 C1 C2 C3 C4	Row 5
0 0 0	C0 C1 C2 C3 C4	Row 6

The user can select eight specific LED brightness levels (Table „Display Brightness“ (page 10)) by changing the peak current driving the LEDs. The peak current is varied by varying the ON time of the row drivers. Note that data line 3 is low (logic 0).

If dimming is required with finer control between 12.5% brightness and 0.0% brightness, data line 3 can be set high (logic 1). The 12.5% peak current is now the brightness reference (100%-E8) for further dimming and as shown in Table “Display Brightness” (page 10) eight levels of dimming are provided. For example the hex code EC in Table “Display Brightness” (page 10) will provide a brightness level 29% lower than the 12.5% brightness level.

Display Brightness

Op code D7 D6 D5	Control Word D4 D3 D2 D1 D0	Hex	Operation Level
1 1 1	0 0 0 0 0	E0	100%
1 1 1	0 0 0 0 1	E1	53%
1 1 1	0 0 0 1 0	E2	40%
1 1 1	0 0 0 1 1	E3	27%
1 1 1	0 0 1 0 0	E4	20%
1 1 1	0 0 1 0 1	E5	13%
1 1 1	0 0 1 1 0	E6	6.6%
1 1 1	0 0 1 1 1	E7	0.0%

The SCE574X offers a unique Display Power Down feature which reduces I_{CC} to less than 50 μ A. When EF_{HEX} is loaded, as shown in Table „Power Down“ (page 10), the display is set to 0% brightness. When in the Power Down mode data may still be written into the RAM. The display is reactivated by loading a new Brightness Level Control Word into the display.

Power Down

Op code D7 D6 D5	Control Word D4 D3 D2 D1 D0	Hex	Operation Level
1 1 1	0 1 1 1 1	EF	0% brightness

The Software Clear (C0_{HEX}), given in Table „Software Clear“ (page 10), clears the Address Register and the RAM. The display is blanked and the Character Address Register will be set to Character 0. The internal counter and the Control Word Register are unaffected. The Software Clear will remain active until the next data input cycle is initiated.

Software Clear

Op code D7 D6 D5	Control Word D4 D3 D2 D1 D0	Hex	Operation Level
1 1 0	0 0 0 0 0	C0	CLEAR

Electrical and Mechanical Considerations

Thermal Considerations

Optimum product performance can be had when the following electrical and mechanical recommendations are adopted. The IC is constructed in a high speed CMOS process, consequently noise on the SERIAL DATA, SERIAL DATA CLOCK, LOAD and RESET lines may cause incorrect data to be written into the serial shift register. Adhere to transmission line termination procedures when using fast line drivers and long cables (> 10 cm).

Good ground and power supply decoupling will insure that I_{CC} (< 400 mA peak) switching currents do not generate localized ground bounce. Therefore it is recommended that each display package use a 0.1 μ F and 0 μ F capacitor between V_{CC} and ground.

When the internal MUX Clock is being used connect the \overline{CLKSEL} pin to V_{CC} . In those applications where RESET will not be connected to the system's reset control, it is recommended that this pin be connected to the center node of a series 0.1 μ F and 100 k Ω RC network. Thus upon initial power up the RESET will be held low for 10 ms allowing adequate time for the system power supply to stabilize.

ESD Protection

The input protection structure of the SCE574x provides significant protection against ESD damage. It is capable of withstanding discharges greater than 2.0 kV. Take all the standard precautions, normal for CMOS components. These include properly grounding personnel, tools, tables, and transport carriers that come in contact with unshielded parts. If these conditions are not, or cannot be met, keep the leads of the device shorted together or the parts in anti-static packaging.

Soldering Considerations

The SCE574x can be hand soldered with SN63 solder using a grounded iron set to 260°C.

Wave soldering is also possible following these conditions: Pre-heat that does not exceed 93°C on the solder side of the PC board or a package surface temperature of 85°C. Water soluble organic acid flux (except carboxylic acid) or rosin-based RMA flux without alcohol can be used.

Wave temperature of 245°C \pm 5°C with a dwell between 1.5 sec. to 3.0 sec. Exposure to the wave should not exceed temperatures above 260°C for five seconds at 1.59 mm (0.063") below the seating plane. The packages should not be immersed in the wave.

Post Solder Cleaning Procedures

The least offensive cleaning solution is hot D.I. water (60°C) for less than 15 minutes. Addition of mild saponifiers is acceptable. Do not use commercial dishwasher detergents.

For faster cleaning, solvents may be used. Exercise care in choosing solvents as some may chemically attack the nylon package. For further information refer to Appnotes 18 and 19.

An alternative to soldering and cleaning the display modules is to use sockets. Naturally, 14 pin DIP sockets 7.62 mm (0.300") wide with 2.54 mm (0.100") centers work well for single displays. Multiple display assemblies are best handled by longer SIP sockets or DIP sockets when available for uniform package alignment.

Optical Considerations

The 4.57 mm (0.180") high character of the SCE574x gives readability up to five feet. Proper filter selection enhances readability over this distance.

Using filters emphasizes the contrast ratio between a lit LED and the character background. This will increase the discrimination of different characters. The only limitation is cost. Take into consideration the ambient lighting environment for the best cost/benefit ratio for filters.

Incandescent (with almost no green) or fluorescent (with almost no red) lights do not have the flat spectral response of sunlight. Plastic band-pass filters are an inexpensive and effective way to strengthen contrast ratios. The SCE5740 is a red display and should be used with long wavelength pass filter having a sharp cut-off in the 600 nm to 620 nm range. The SCE5742 is a super-red display and should be used with long wavelength pass filter having a sharp cut-off in the 570 nm to 600 nm range. The SCE5744 is a high efficiency green display and should be used with long wavelength pass filter that peaks at 565 nm.

Additional contrast enhancement is gained by shading the displays. Plastic band-pass filters with built-in louvers offer the next step up in contrast improvement. Plastic filters can be improved further with anti-reflective coatings to reduce glare.

Optimal filter enhancements are gained by using circular polarized, anti-reflective, band-pass filters. The circular polarizing further enhances contrast by reducing the light that travels through the filter and reflects back off the display to less than 1%.

Several filter manufacturers supply quality filter materials. Some of them are: Panelgraphic Corporation, W. Caldwell, NJ; SGL Homa-lite, Wilmington, DE; 3M Company, Visual Products Division, St. Paul, MN; Polaroid Corporation, Polarizer Division, Cambridge, MA; Marks Polarized Corporation, Deer Park, NY; Hoya Optics, Inc., Fremont, CA. One last note on mounting filters: recessing displays and bezel assemblies is an inexpensive way to provide a shading effect in overhead lighting situations. Several Bezel manufacturers are: R.M.F. Products, Batavia, IL; Nobex Components, Griffith Plastic Corp., Burlingame, CA; Photo Chemical Products of California, Santa Monica, CA; I.E.E.-Atlas, Van Nuys, CA. The trade-off is fuzzy characters. Mounting the filters close to the display reduces this effect. Take care not to overheat the plastic filter by allowing for proper air flow.

Microprocessor Interface

The microprocessor interface is through the serial port, SPI port or one out of eight data bits on the eight bit parallel port and also control lines SDCLK and LOAD.

Power Up Sequence

Upon power up display will come on at random. Thus the display should be reset at power-up. The reset will set the Address Register to Digit 0, User RAM is set to 0 (display blank) the Control Word is set to 0 (100% brightness) and the internal counters are reset.

Display Interface to Siemens/Intel 8031 Microprocessor (using serial port in mode 0)

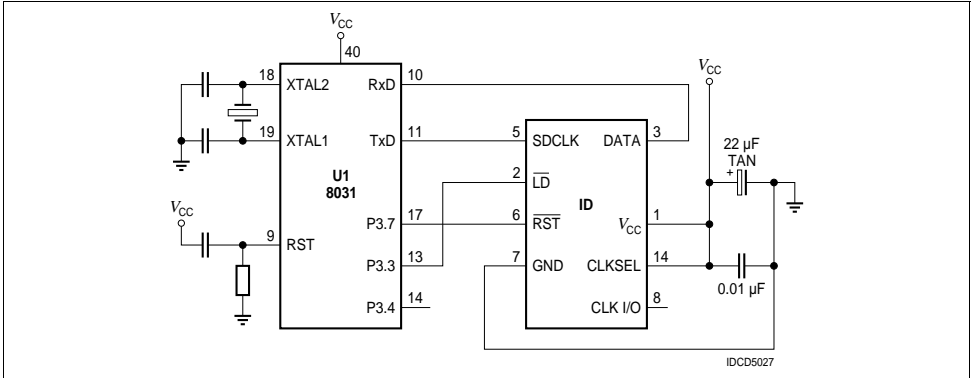

Display Interface to Siemens/Intel 8031 Microprocessor (using one bit of parallel port as serial port)

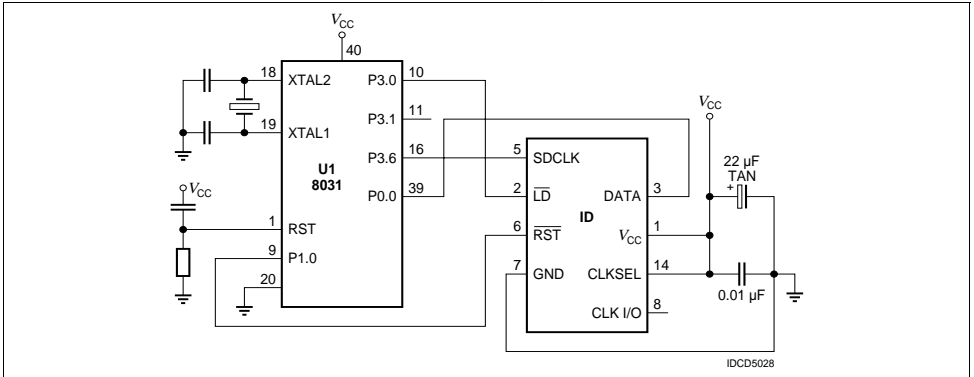

Display Interface with Motorola 68HC05C4 Microprocessor (using SPI port)

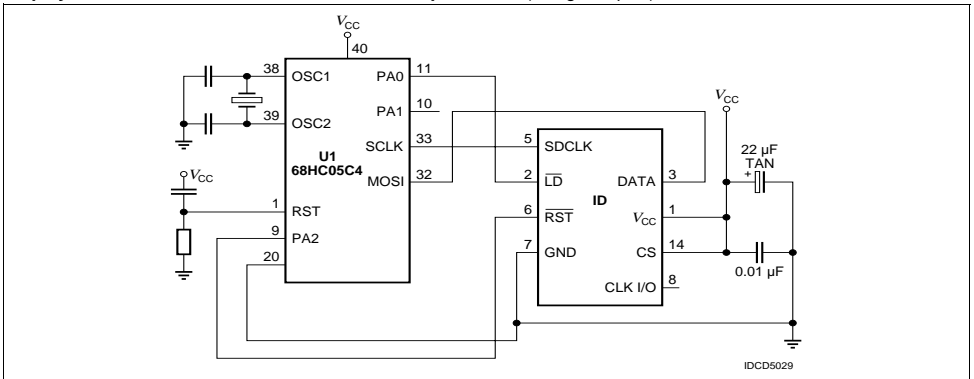

Cascading Multiple Displays using only the SCE574x.

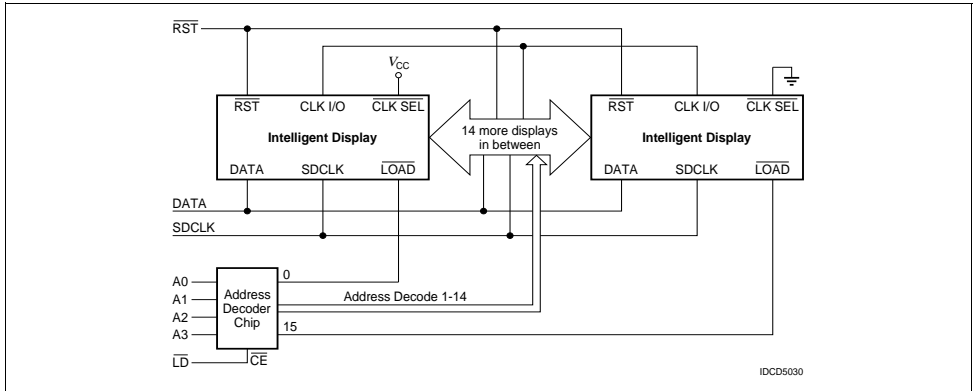

Multiple displays can be cascaded using the CLK SEL and CLK I/O pins (Figure „Cascading Multiple Displays using only the SCE574X“ (page 13)). The display designated as the MasterClock source should have its CLK SEL pin tied high and the slaves should have their CLK SEL pins tied low. All CLK I/O pins should be tied together. One display CLK I/O can drive 15 slave CLK I/Os. Use RST to synchronize all display counters.

Loading Data into the Display

Use following procedure to load data into the display:

1. Power up the display.
2. Bring RST low (600 ns duration minimum) to clear the Multiplex Counter, Address Register, Control Word Register, User Ram and Data Register. The display will be blank. Display brightness is set to 100%.
3. If a different brightness is desired, load the proper brightness opcode into the Control Word Register.
4. Load the Digit Address into the display.
5. Load display row and column data for the selected digit.
6. Repeat steps 4 and 5 for all digits.

Data Contents for the Word “ABCD”

Step	D7	D6	D5	D4	D3	D2	D1	D0	Function
A	1	1	1	0	0	0	0	0	CLEAR
B (optional)	1	1	1	0	0	0	0	0	100% BRIGHTNESS
1	1	0	1	0	0	0	0	0	DIGIT D0 SELECT
2	0	0	0	0	0	1	0	0	ROW 0 (A)
3	0	0	0	0	1	0	1	0	ROW 1 (A)
4	0	0	0	1	0	0	0	1	ROW 2 (A)
5	0	0	0	1	1	1	1	1	ROW 3 (A)
6	0	0	0	1	0	0	0	1	ROW 4 (A)
7	0	0	0	1	0	0	0	1	ROW 5 (A)
8	0	0	0	1	0	0	0	1	ROW 6 (A)
9	1	0	1	0	0	0	0	1	DIGIT D1 SELECT
10	0	0	0	1	1	1	1	1	ROW 0 (B)
11	0	0	0	1	0	0	0	1	ROW 1 (B)
12	0	0	0	1	0	0	0	1	ROW 2 (B)
13	0	0	0	1	1	1	1	0	ROW 3 (B)
14	0	0	0	1	0	0	0	1	ROW 4 (B)
15	0	0	0	1	0	0	0	1	ROW 5 (B)
16	0	0	0	1	1	1	1	1	ROW 6 (B)
17	1	0	1	0	0	0	1	0	DIGIT D2 SELECT
18	0	0	0	0	0	1	1	1	ROW 0 (C)
19	0	0	0	0	1	0	0	0	ROW 1 (C)
20	0	0	0	1	0	0	0	0	ROW 2 (C)
21	0	0	0	1	0	0	0	0	ROW 3 (C)
22	0	0	0	1	0	0	0	0	ROW 4 (C)
23	0	0	0	0	1	0	0	0	ROW 5 (C)
24	0	0	0	0	0	1	1	1	ROW 6 (C)
25	1	0	1	0	0	0	1	1	DIGIT D3 SELECT
26	0	0	0	1	1	1	1	0	ROW 0 (D)
27	0	0	0	1	0	0	0	1	ROW 1 (D)
28	0	0	0	1	0	0	0	1	ROW 2 (D)
29	0	0	0	1	0	0	0	1	ROW 3 (D)
30	0	0	0	1	0	0	0	1	ROW 4 (D)
31	0	0	0	1	0	0	0	1	ROW 5 (D)
32	0	0	0	1	1	1	1	0	ROW 6 (D)

SCE5740, SCE5741, SCE5742, SCE5743, SCE5744, SCE5745

Detail Drawing of SCE574x

Dimensions in inch (mm)

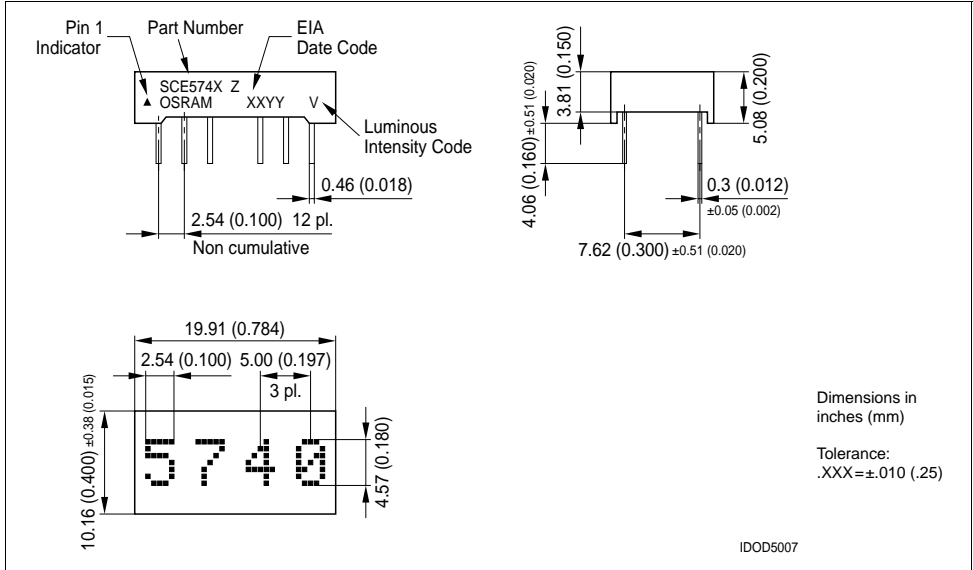

Pin Functions for SCE574x

Pin #	Function	Pin #	Function	Top View	Typical Character
1	V _{cc}	6	RESET		
2	Load	7	GROUND		
3	Data	8	CLK I/O		
4	No Pin	9—13	No Pins		
5	SDCLK	14	CLK SELECT		

IDOD5008

SCE5740, SCE5741, SCE5742, SCE5743, SCE5744, SCE5745

Detail Drawing of SCE574xP (SIP configuration)

Dimensions in inch (mm)

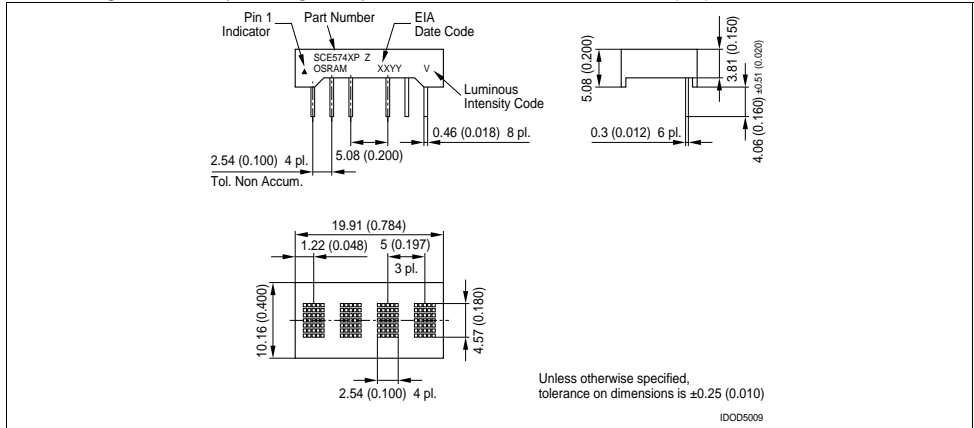

Detail Drawing of SCE574xQ (SIP configuration with right angle bend)

Dimensions in inch (mm)

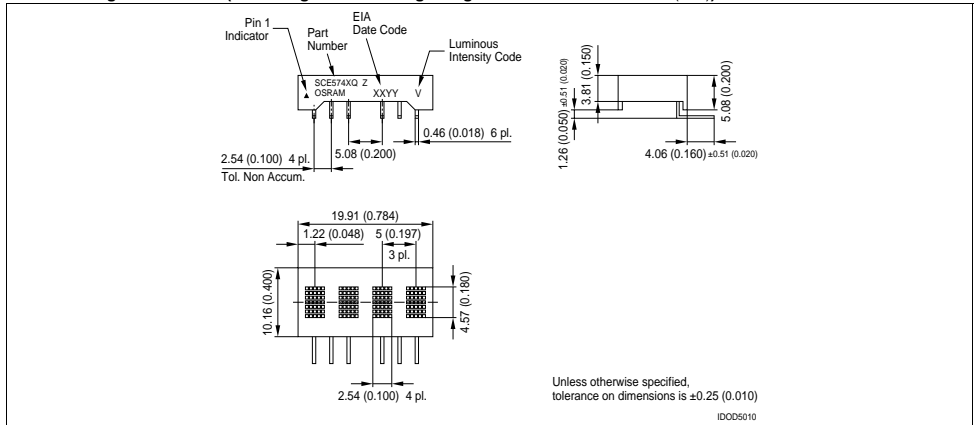

Pin Functions for SCE574xP and SCE574xQ

Pin #	Function	Top View	Typical Character
1	V _{CC}	<p>Pin 1 Pin 7 IDPA5108</p>	<p>0.71 (0.028) 0.56 (0.022) IDOD5011</p>
2	Load		
3	Data		
4	No Pin		
5	SDCLK		
6	RESET		
7	GND		

2006-03-30

15

Revision History: 2006-03-30

Previous Version: 2005-01-10

Page	Subjects (major changes since last revision)	Date of change
all	Lead free device	2006-01-23

Published by
OSRAM Opto Semiconductors GmbH
 Wernerwerkstrasse 2, D-93049 Regensburg
www.osram-os.com
 © All Rights Reserved.

Attention please!

The information describes the type of component and shall not be considered as assured characteristics. Terms of delivery and rights to change design reserved. Due to technical requirements components may contain dangerous substances. For information on the types in question please contact our Sales Organization. If printed or downloaded, please find the latest version in the Internet.

Packing

Please use the recycling operators known to you. We can also help you – get in touch with your nearest sales office. By agreement we will take packing material back, if it is sorted. You must bear the costs of transport. For packing material that is returned to us unsorted or which we are not obliged to accept, we shall have to invoice you for any costs incurred.

Components used in life-support devices or systems must be expressly authorized for such purpose! Critical components¹⁾ may only be used in life-support devices or systems²⁾ with the express written approval of OSRAM OS.

- 1) A critical component is a component used in a life-support device or system whose failure can reasonably be expected to cause the failure of that life-support device or system, or to affect its safety or the effectiveness of that device or system.
- 2) Life support devices or systems are intended (a) to be implanted in the human body, or (b) to support and/or maintain and sustain human life. If they fail, it is reasonable to assume that the health and the life of the user may be endangered.