

## Positive Voltage Regulators

## GENERAL DESCRIPTION

The XC6201 series are highly precise, low power consumption, positive voltage regulators manufactured using CMOS and laser trimming technologies.

The series provides large currents with a significantly small dropout voltage.

The XC6201 consists of a current limiter circuit, a driver transistor, a precision reference voltage and an error amplifier. Output voltage is selectable in 100mV steps between 1.3V ~ 6.0V. SOT-25 (250mW), SOT-89 (500mW), USP-6B (100mW) and TO-92 (300mW) packages are available.

## APPLICATIONS

Mobile Phones  
Cordless phones, wireless communication equipment  
Cameras, video recorders  
Portable games  
Portable AV equipment  
Reference voltage  
Battery powered equipment

## FEATURES

<b>Maximum Output Current</b>	: 250mA (TYP.)
<b>Dropout Voltage</b>	: 0.16V @ 100mA : 0.40V @ 200mA
<b>Maximum Operating Voltage</b>	: 10V
<b>Output Voltage Range</b>	: 1.3V ~ 6.0V (selectable in 100mV increments)
<b>Highly Accurate</b>	: Fixed voltage accuracy $\pm 1\%$ ( $\pm 1\%$ @ $V_{OUT(T)} \geq 2.0V$ ) : $\pm 2\%$
<b>Low Power Consumption</b>	: 2.0 $\mu$ A (TYP.)
<b>Operational Temperature Range</b>	: -40 ~ 85
<b>Ultra Small Packages</b>	: SOT-25 (250mW), SOT-89 (500mW), TO-92 (300mW), USP-6B (100mW)

Tantalum or Ceramic Capacitor compatible

## TYPICAL APPLICATION CIRCUIT

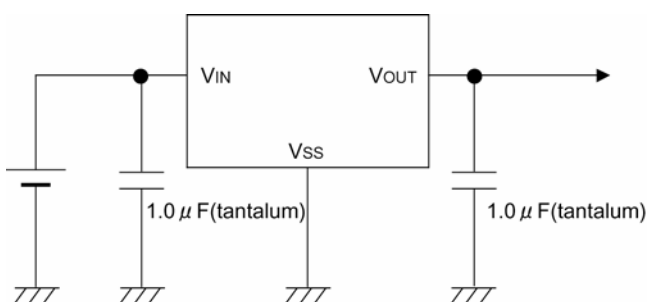

## TYPICAL PERFORMANCE CHARACTERISTICS

Supply Current vs. Input Voltage

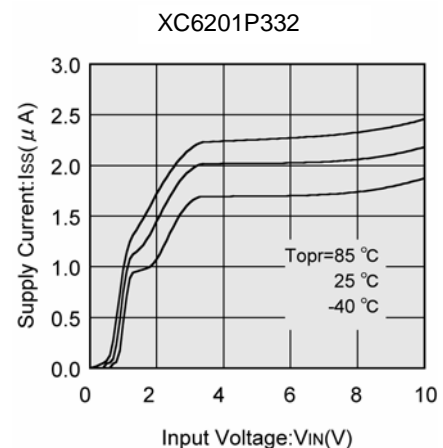

## PIN CONFIGURATION

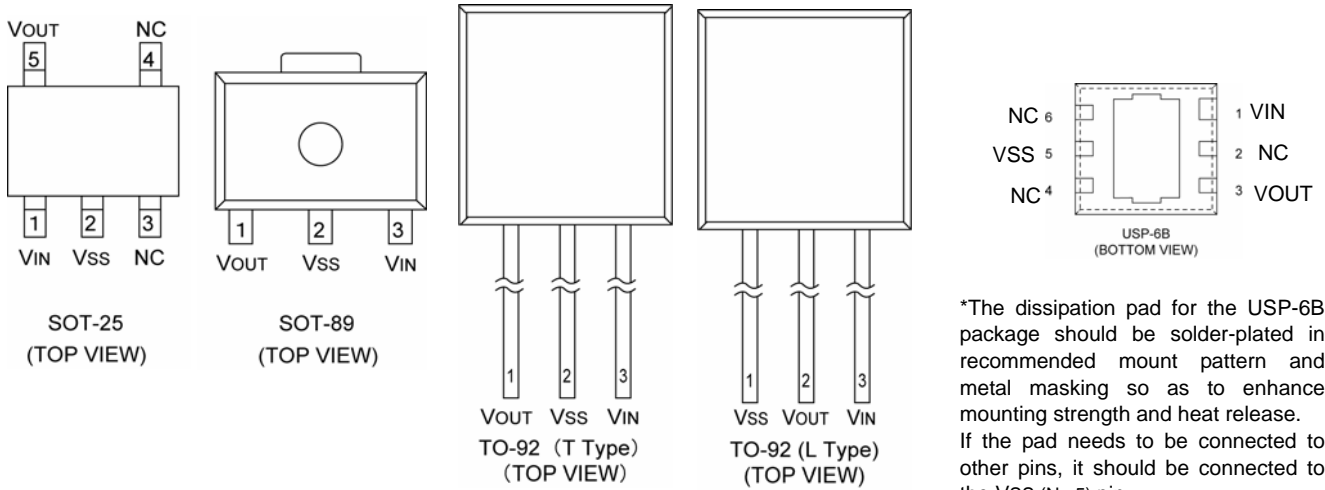

\*The dissipation pad for the USP-6B package should be solder-plated in recommended mount pattern and metal masking so as to enhance mounting strength and heat release. If the pad needs to be connected to other pins, it should be connected to the VSS (No.5) pin.

## PIN ASSIGNMENT

PIN NUMBER				PIN NAME	FUNCTION
SOT-25	SOT-89/TO-92 (T)	TO-92 (L)	USP-6B		
5	1	2	3	VOUT	Output
2	2	1	5	VSS	Ground
1	3	3	1	VIN	Power Input
3, 4	-	-	2,4,6	NC	No Connection

## PRODUCT CLASSIFICATION

Ordering Information

XC6201P  
 ↑ ↑

DESIGNATOR	DESCRIPTION	SYMBOL	DESCRIPTION
	Product Number	01	: -
	Type of Regulator	P	: 3-pin regulator
	Output Voltage	13 ~ 60	: e.g. 30:3.0V 50:5.0V
	Output Voltage Accuracy	1	: ± 1%
		2	: ± 2%
	Packages	M	: SOT-25
		P	: SOT-89
		T	: TO-92 (Standard)
		L	: TO-92 (Custom pin configuration)
		D	: USP-6B
	Device Orientation	R	: Embossed tape, standard feed
		L	: Embossed tape, reverse feed
		H	: Paper type (TO-92)
		B	: Bag (TO-92)

\* ±1% accuracy can be set at  $V_{OUT(T)} \geq 2.0V$ .

## BLOCK DIAGRAM

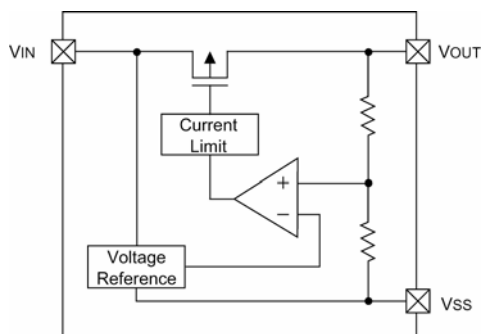

## ABSOLUTE MAXIMUM RATINGS

Ta = 25

PARAMETER		SYMBOL	RATINGS	UNITS
Input Voltage		VIN	12.0	V
Output Current		IOUT	500	mA
Output Voltage		VOUT	VSS-0.3 ~ VIN+0.3	V
Power Dissipation	SOT-25	Pd	250	mW
	SOT-89		500	
	TO-92		300	
	USP-6B		100	
Operating Temperature Range		Topr	-40 ~ +85	
Storage Temperature Range		Tstg	-55 ~ +125	

## ELECTRICAL CHARACTERISTICS

XC6201P132 VOUT(T)=1.3V <sup>(\*)</sup>

Ta=25

PARAMETER	SYMBOL	CONDITIONS	MIN.	TYP.	MAX.	UNITS	CIRCUIT
Output Voltage	VOUT(E) <sup>(*)</sup>	VIN=2.3V IOUT=10mA	1.274	1.300	1.326	V	
Maximum Output Current	IOUTmax	VIN=2.3V VOUT(E) 1.17V	60	-	-	mA	
Load Regulation	VOUT	VIN=2.3V 1mA IOUT 30mA	-	10	30	mV	
Dropout Voltage <sup>(*)</sup>	Vdif1	IOUT=30mA	-	200	600	mV	
	Vdif2	IOUT=60mA	-	500	810		
Supply Current	ISS	VIN=2.3V	-	2.0	5.0	μA	
Line Regulation	$\frac{V_{OUT}}{V_{IN}} \cdot V_{OUT}$	IOUT=10mA 2.3V VIN 10.0V	-	0.2	0.3	%/V	
Input Voltage	VIN		1.8	-	10	V	-
Output Voltage Temperature Characteristics	$\frac{V_{OUT}}{T_{opr}} \cdot V_{OUT}$	IOUT=40mA -40 Topr 85	-	± 100	-	ppm/	

## ELECTRICAL CHARACTERISTICS (Continued)

XC6201P182  $V_{OUT(T)}=1.8V$  <sup>(\*1)</sup>

Ta=25

PARAMETER	SYMBOL	CONDITIONS	MIN.	TYP.	MAX.	UNITS	CIRCUIT
Output Voltage	$V_{OUT(E)}$ <sup>(*2)</sup>	$V_{IN}=2.8V$ $I_{OUT}=40mA$	1.764	1.800	1.836	V	
Maximum Output Current	$I_{OUTmax}$	$V_{IN}=2.8V$ $V_{OUT(E)} 1.62V$	80	-	-	mA	
Load Regulation	$V_{OUT}$	$V_{IN}=2.8V$ $1mA I_{OUT} 40mA$	-	10	30	mV	
Dropout Voltage <sup>(*3)</sup>	$V_{dif1}$	$I_{OUT}=40mA$	-	200	370	mV	
	$V_{dif2}$	$I_{OUT}=80mA$	-	450	710		
Supply Current	$I_{SS}$	$V_{IN}=2.8V$	-	2.0	5.0	$\mu A$	
Line Regulation	$\frac{V_{OUT}}{V_{IN} \cdot V_{OUT}}$	$I_{OUT}=40mA$ $2.8V V_{IN} 10.0V$	-	0.2	0.3	%/V	
Input Voltage	$V_{IN}$		1.8	-	10	V	-
Output Voltage Temperature Characteristics	$\frac{V_{OUT}}{Topr \cdot V_{OUT}}$	$I_{OUT}=40mA$ $-40 Topr 85$	-	$\pm 100$	-	ppm/	

XC6201P272  $V_{OUT(T)}=2.7V$  <sup>(\*1)</sup>

Ta=25

PARAMETER	SYMBOL	CONDITIONS	MIN.	TYP.	MAX.	UNITS	CIRCUIT
Output Voltage	$V_{OUT(E)}$ <sup>(*2)</sup>	$V_{IN}=3.7V$ $I_{OUT}=40mA$	2.646	2.700	2.754	V	
Maximum Output Current	$I_{OUTmax}$	$V_{IN}=3.7V$ $V_{OUT(E)} 2.43V$	100	-	-	mA	
Load Regulation	$V_{OUT}$	$V_{IN}=3.7V$ $1mA I_{OUT} 60mA$	-	15	40	mV	
Dropout Voltage <sup>(*3)</sup>	$V_{dif1}$	$I_{OUT}=60mA$	-	200	370	mV	
	$V_{dif2}$	$I_{OUT}=120mA$	-	450	710		
Supply Current	$I_{SS}$	$V_{IN}=3.7V$	-	2.0	5.0	$\mu A$	
Line Regulation	$\frac{V_{OUT}}{V_{IN} \cdot V_{OUT}}$	$I_{OUT}=40mA$ $3.7V V_{IN} 10.0V$	-	0.2	0.3	%/V	
Input Voltage	$V_{IN}$		1.8	-	10	V	-
Output Voltage Temperature Characteristics	$\frac{V_{OUT}}{Topr \cdot V_{OUT}}$	$I_{OUT}=40mA$ $-40 Topr 85$	-	$\pm 100$	-	ppm/	

## ELECTRICAL CHARACTERISTICS (Continued)

XC6201P332

$V_{OUT(T)}=3.3V$  <sup>(\*1)</sup>

Ta=25

PARAMETER	SYMBOL	CONDITIONS	MIN.	TYP.	MAX.	UNITS	CIRCUIT
Output Voltage	$V_{OUT(E)}$ <sup>(*2)</sup>	$V_{IN}=4.3V$ $I_{OUT}=40mA$	3.234	3.300	3.366	V	
Maximum Output Current	$I_{OUTmax}$	$V_{IN}=4.3V$ $V_{OUT(E)} 2.97V$	150	-	-	mA	
Load Regulation	$V_{OUT}$	$V_{IN}=4.3V$ $1mA I_{OUT} 80mA$	-	20	50	mV	
Dropout Voltage <sup>(*3)</sup>	Vdif1	$I_{OUT}=80mA$	-	200	360	mV	
	Vdif2	$I_{OUT}=160mA$	-	450	700		
Supply Current	$I_{SS}$	$V_{IN}=4.3V$	-	2.0	5.0	$\mu A$	
Line Regulation	$\frac{V_{OUT}}{V_{IN} \cdot V_{OUT}}$	$I_{OUT}=40mA$ $4.3V V_{IN} 10.0V$	-	0.2	0.3	%/V	
Input Voltage	$V_{IN}$		1.8	-	10	V	-
Output Voltage Temperature Characteristics	$\frac{V_{OUT}}{Topr \cdot V_{OUT}}$	$I_{OUT}=40mA$ $-40 Topr 85$	-	$\pm 100$	-	ppm/	

XC6201P502

$V_{OUT(T)}=5.0V$  <sup>(\*1)</sup>

Ta=25

PARAMETER	SYMBOL	CONDITIONS	MIN.	TYP.	MAX.	UNITS	CIRCUIT
Output Voltage	$V_{OUT(E)}$ <sup>(*2)</sup>	$V_{IN}=6.0V$ $I_{OUT}=40mA$	4.900	5.000	5.100	V	
Maximum Output Current	$I_{OUTmax}$	$V_{IN}=6.0V$ $V_{OUT(E)} 4.57V$	200	-	-	mA	
Load Regulation	$V_{OUT}$	$V_{IN}=6.0V$ $1mA I_{OUT} 100mA$	-	30	70	mV	
Dropout Voltage <sup>(*3)</sup>	Vdif1	$I_{OUT}=100mA$	-	160	340	mV	
	Vdif2	$I_{OUT}=200mA$	-	400	600		
Supply Current	$I_{SS}$	$V_{IN}=6.0V$	-	2.0	6.0	$\mu A$	
Line Regulation	$\frac{V_{OUT}}{V_{IN} \cdot V_{OUT}}$	$I_{OUT}=40mA$ $6.0V V_{IN} 10.0V$	-	0.2	0.3	%/V	
Input Voltage	$V_{IN}$		1.8	-	10	V	-
Output Voltage Temperature Characteristics	$\frac{V_{OUT}}{Topr \cdot V_{OUT}}$	$I_{OUT}=40mA$ $-40 Topr 85$	-	$\pm 100$	-	ppm/	

**NOTE:**

- \*1:  $V_{OUT(T)}$  = Specified output voltage.
- \*2:  $V_{OUT(E)}$  = Effective output voltage (i.e. the output voltage when " $V_{OUT(T)}+1.0V$ " is provided while maintaining a certain  $I_{OUT}$  value).
- \*3:  $V_{dif} = \{ V_{IN1}^{(*5)} - V_{OUT1}^{(*4)} \}$
- \*4:  $V_{OUT1}$  = A voltage equal to 98% of the output voltage when a stabilized ( $V_{OUT(T)} + 1.0V$ ) is input.
- \*5:  $V_{IN1}$  = The input voltage at the time  $V_{OUT1}$  is output input voltage has been gradually reduced.

## TYPICAL APPLICATION CIRCUIT

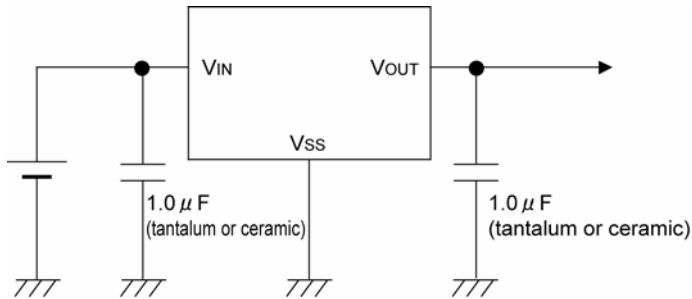

With the XC6201 series regulator, in order to ensure the stabilized output voltage, we suggest that an output capacitor ( $C_L$ ) of  $1 \mu F$  or more be connected between the output pin ( $V_{OUT}$ ) and the  $V_{SS}$  pin. For using low ESR capacitor (e.g. ceramic capacitors), please make sure that the output voltage is more than 1.7V. When the output voltage is from 1.3V to 1.6V, the output capacitor should be a tantalum capacitor with a capacitance of  $2.2 \mu F$ . We also suggest an input capacitor ( $C_{IN}$ ) should be connected between the  $V_{IN}$  and the  $V_{SS}$  in order to stabilize input power source.

OUTPUT VOLTAGE	$C_{IN}$	$C_L$ (TANTALUM)	$C_L$ (LOW ESR)
1.3V ~ 1.6V	More Than $1.0 \mu F$	More Than $2.2 \mu F$	-
1.7V ~ 6.0V	More Than $1.0 \mu F$	More Than $1.0 \mu F$	More Than $0.1 \mu F$

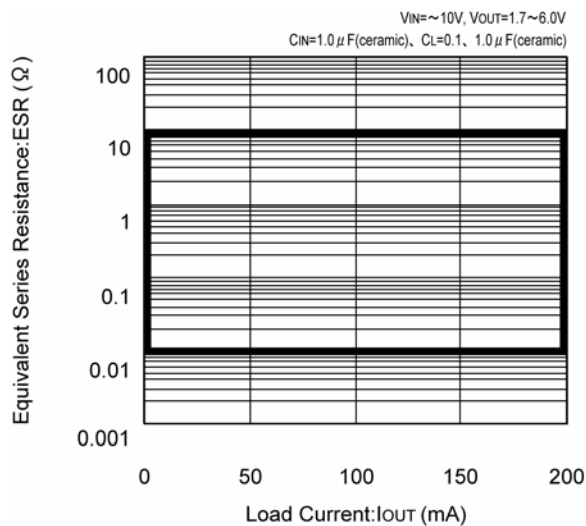

## TEST CIRCUITS

Circuit : Supply Current

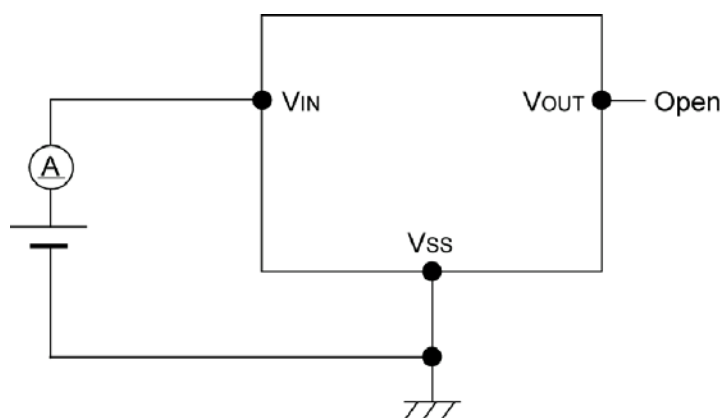

Circuit : Output Voltage, Oscillation, Line Regulation, Dropout Voltage, Load Regulation

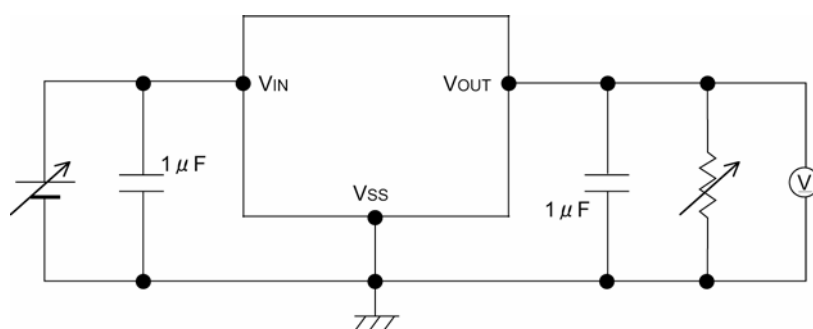

## NOTE ON USE

1. Please use this IC within the stated absolute maximum ratings. The IC is liable to malfunction should the ratings be exceeded. When a voltage higher than the  $V_{IN}$  flows to the  $V_{OUT}$  like when using two power supplies, please connect a Schottky barrier diode between the  $V_{OUT}$  and the  $V_{IN}$  and do not exceed the  $V_{OUT}$  rating.
2. An oscillation may occur by the impedance between a power supply and the input of the IC. Where the impedance is 10 or more, please use an input capacitor ( $C_{IN}$ ) of at least  $1 \mu F$ . In case of high output current, operation can be stabilized by increasing the input capacitor value. Also an oscillation may occur if the input capacitor value is smaller than the input impedance when the output capacitance ( $C_L$ ) is large. In such cases, operations can be stabilized by either increasing the input capacitor value or reducing the output capacitor value.
3. Please ensure that output current ( $I_{OUT}$ ) is less than  $P_d / (V_{IN} - V_{OUT})$  and do not exceed the rated power dissipation value ( $P_d$ ) of the package.

## TYPICAL PERFORMANCE CHARACTERISTICS

### (1) Output Voltage vs. Output Current

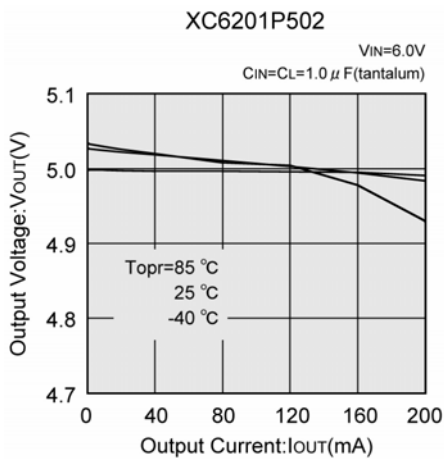
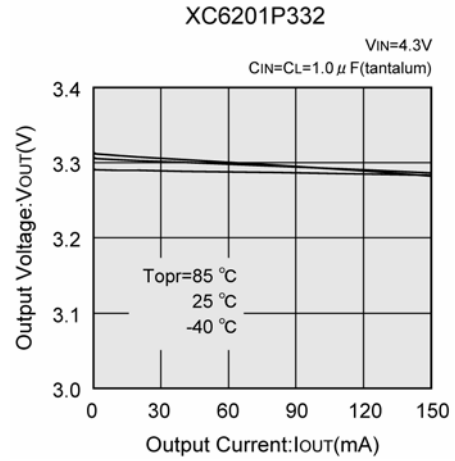
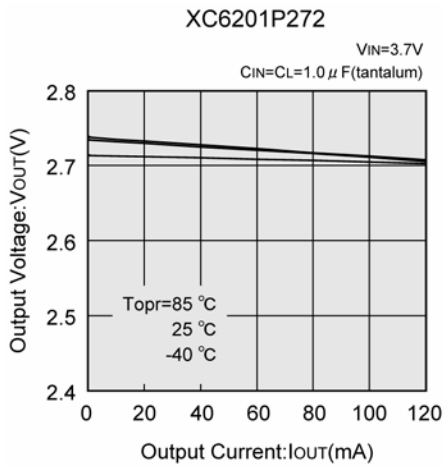
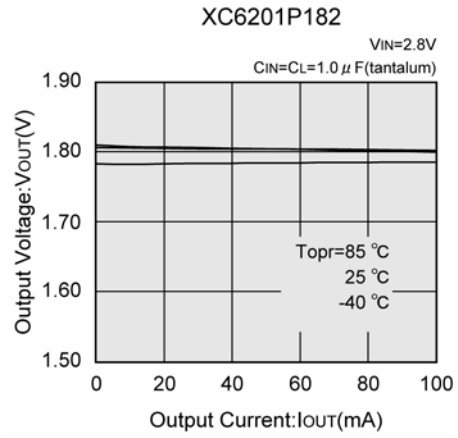
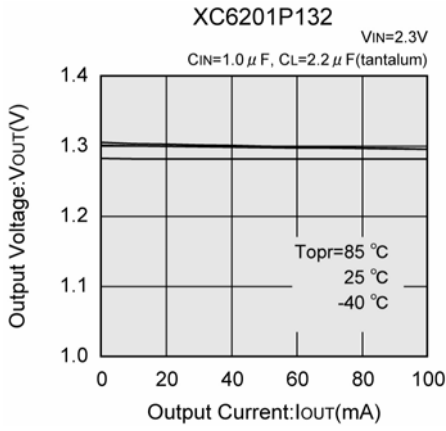



## TYPICAL PERFORMANCE CHARACTERISTICS (Continued)

### (2) Output Voltage vs. Input Voltage

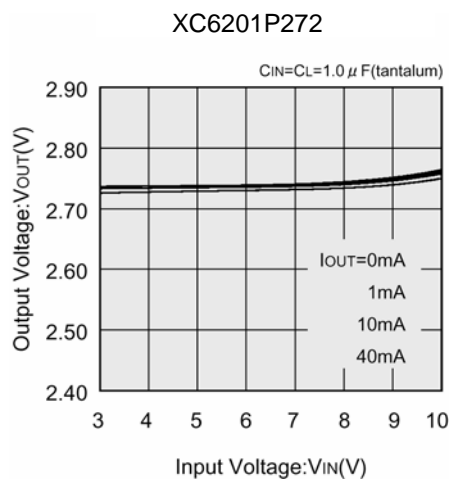
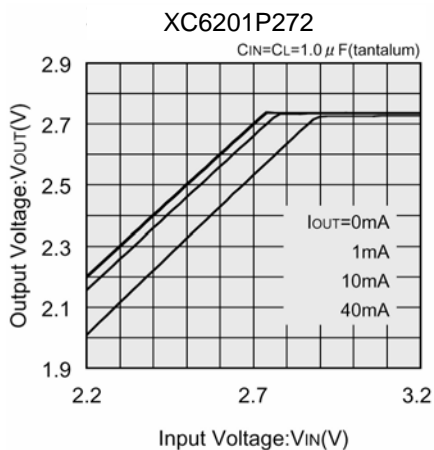
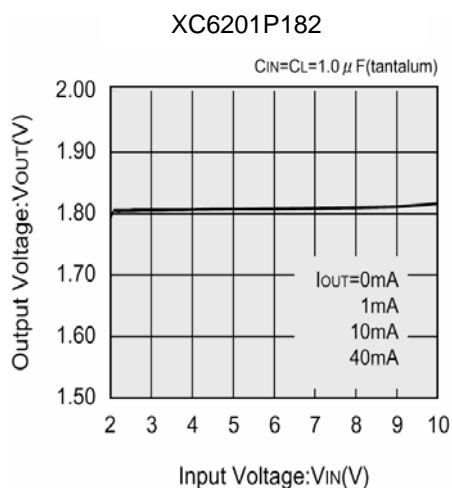
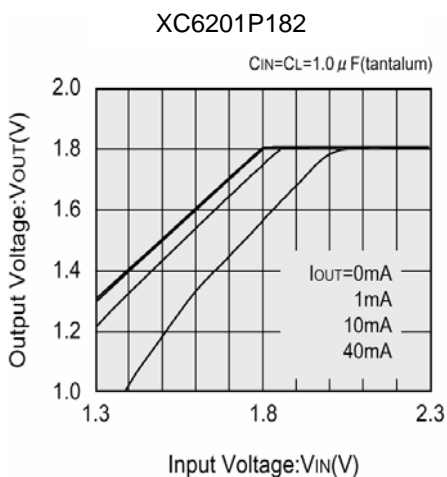
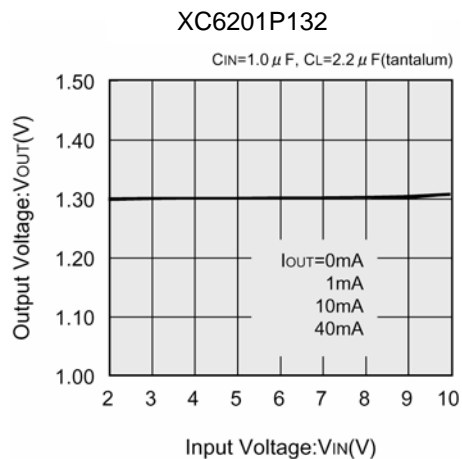
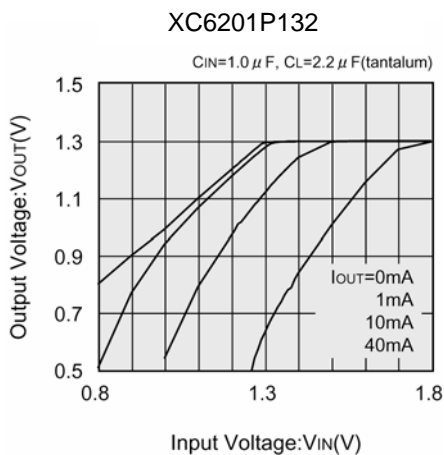

## TYPICAL PERFORMANCE CHARACTERISTICS (Continued)

### (2) Output Voltage vs. Input Voltage (Continued)

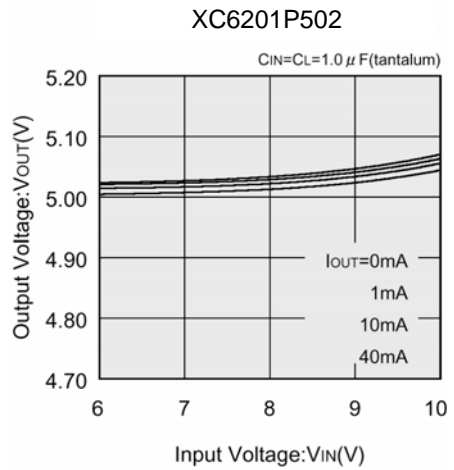
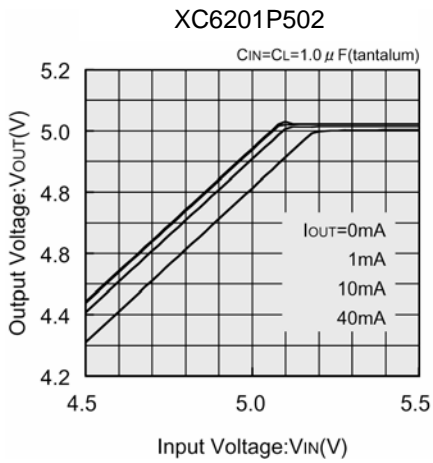
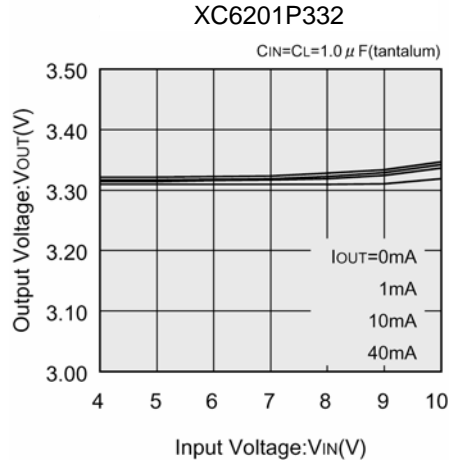
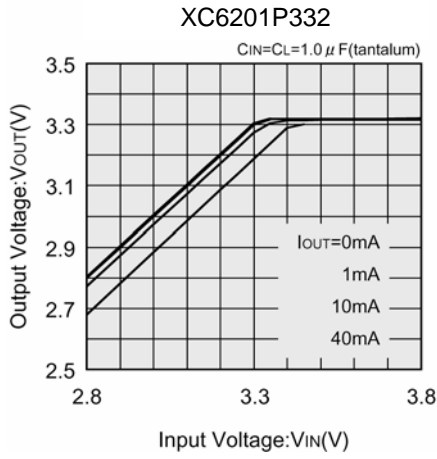

## TYPICAL PERFORMANCE CHARACTERISTICS (Continued)

### (3) Dropout Voltage vs. Output Current

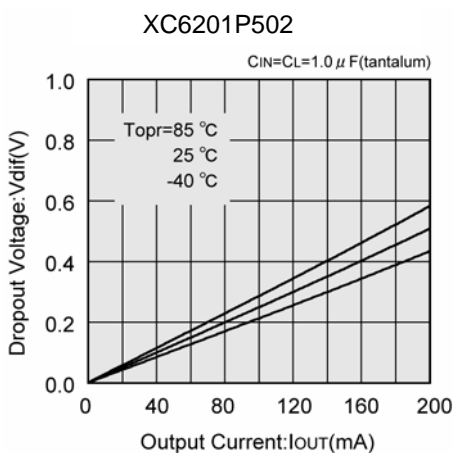
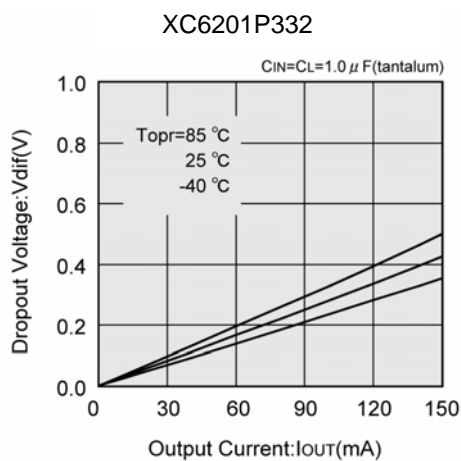
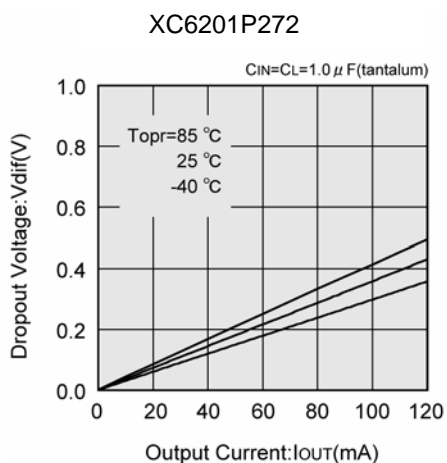
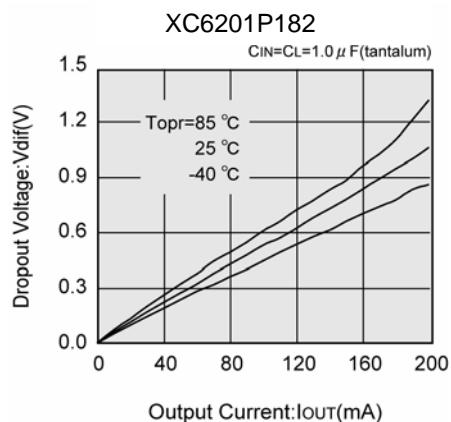
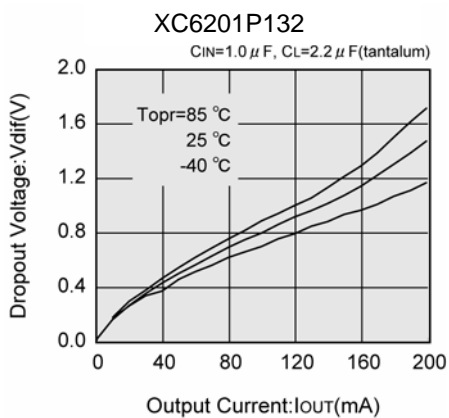

## TYPICAL PERFORMANCE CHARACTERISTICS (Continued)

### (4) Supply Current vs. Input Voltage

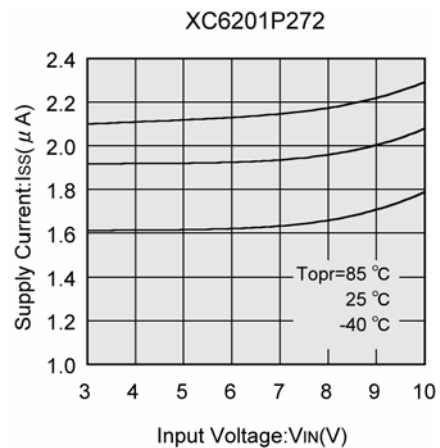
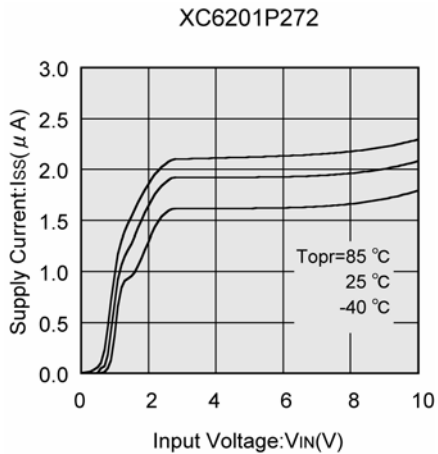
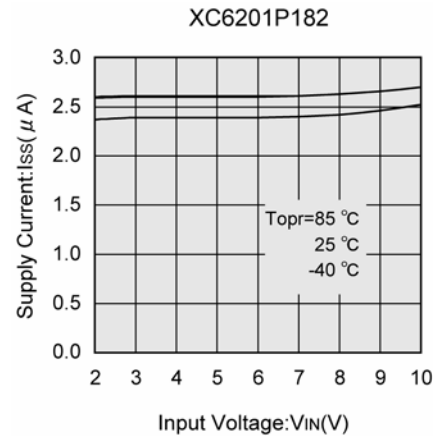
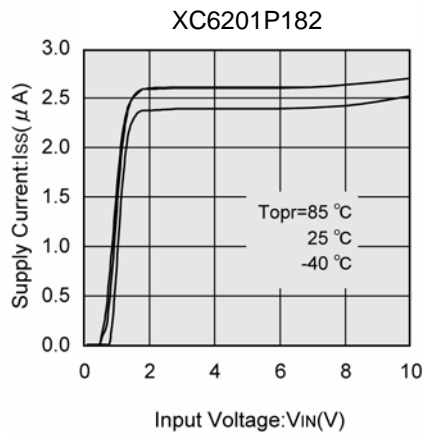
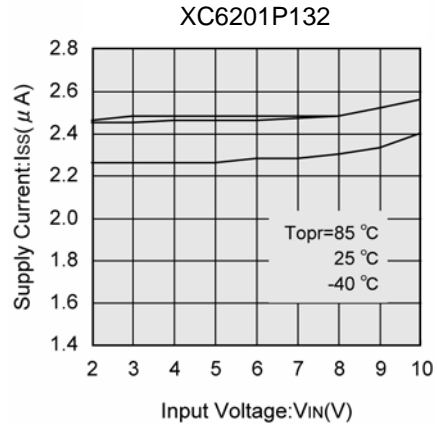
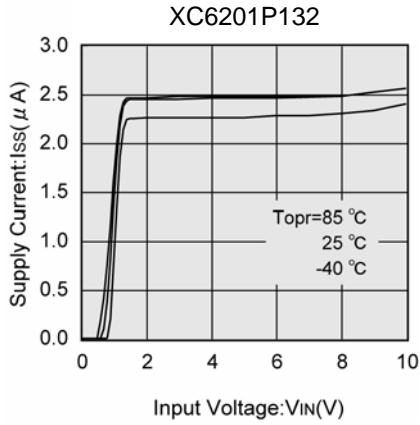

## TYPICAL PERFORMANCE CHARACTERISTICS (Continued)

### (4) Supply Current vs. Input Voltage (Continued)

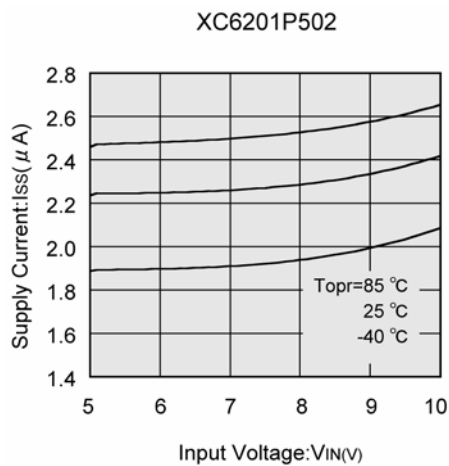
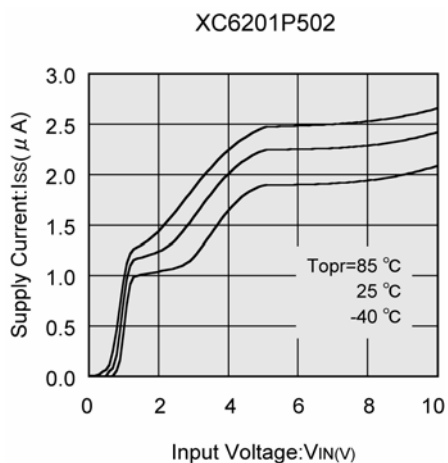
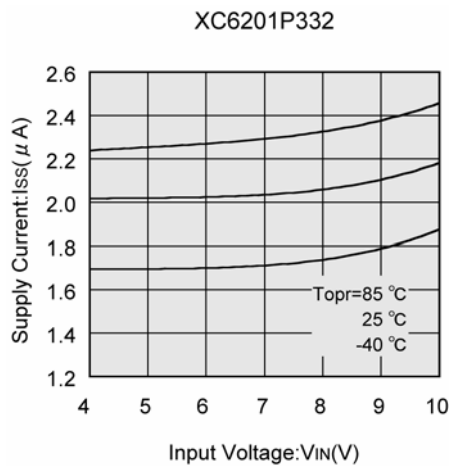
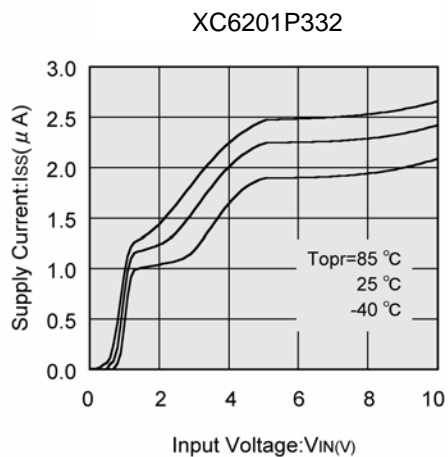

## TYPICAL PERFORMANCE CHARACTERISTICS (Continued)

### (5) Output Voltage vs. Ambient Temperature

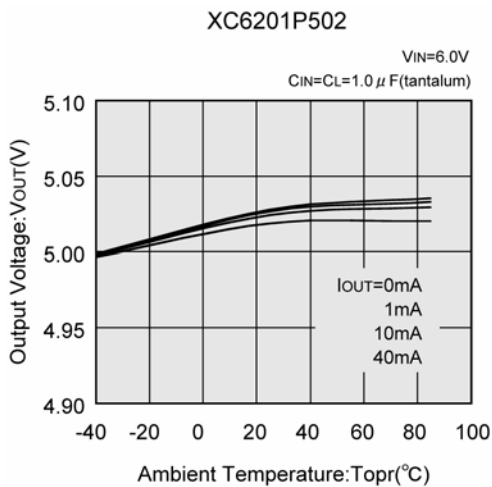
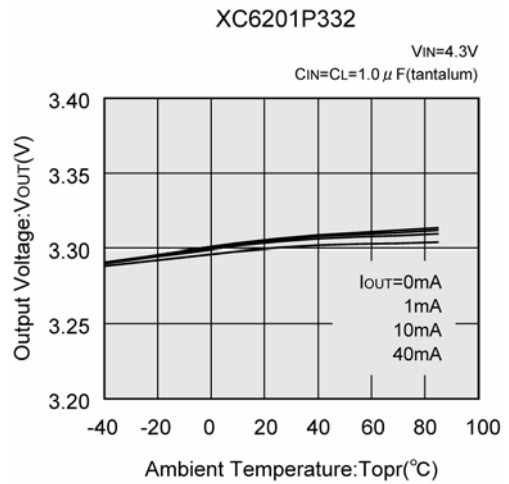
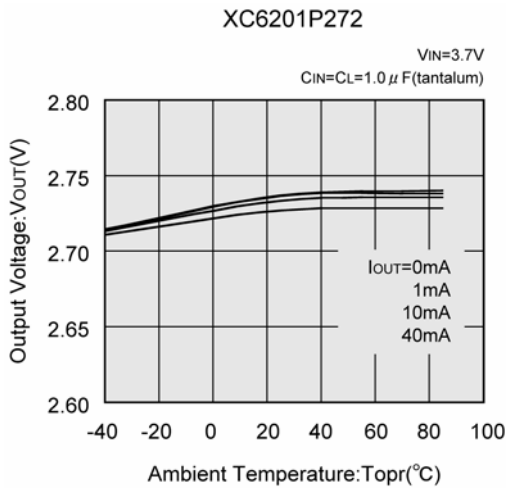
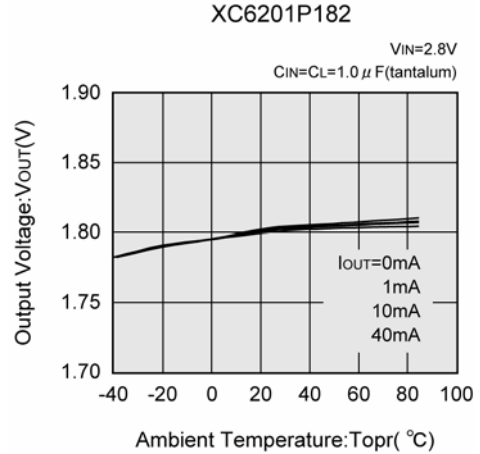
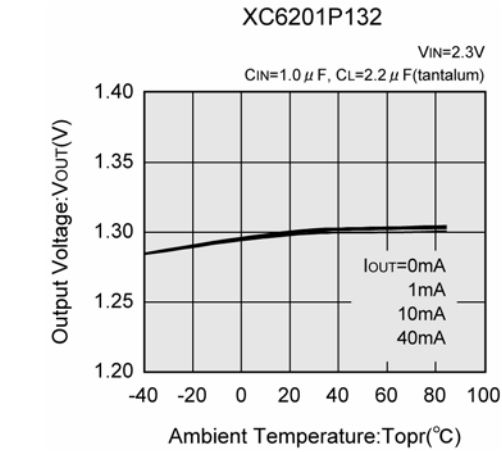

## TYPICAL PERFORMANCE CHARACTERISTICS (Continued)

### (6) Supply Current vs. Ambient Temperature

XC6201P132

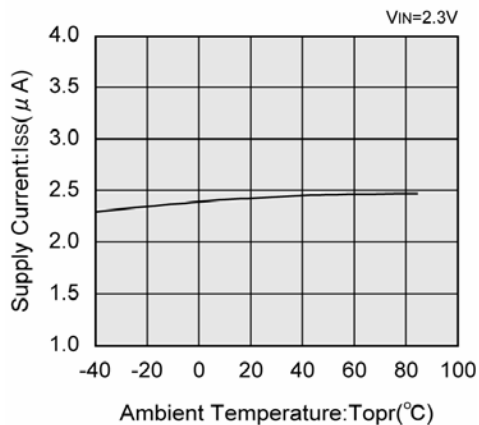

XC6201P182

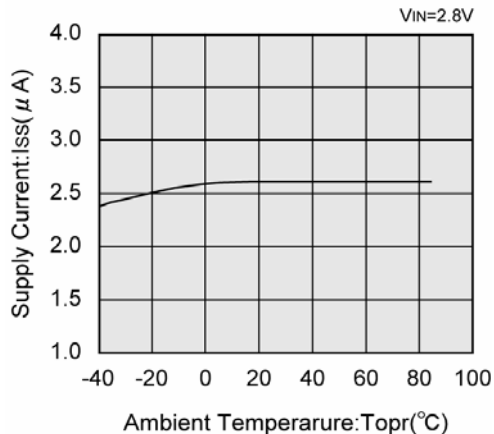

XC6201P272

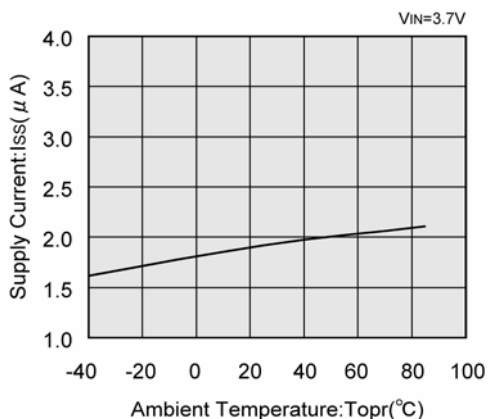

XC6201P332

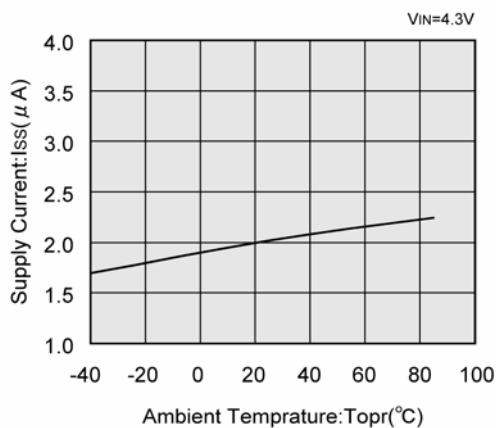

XC6201P502

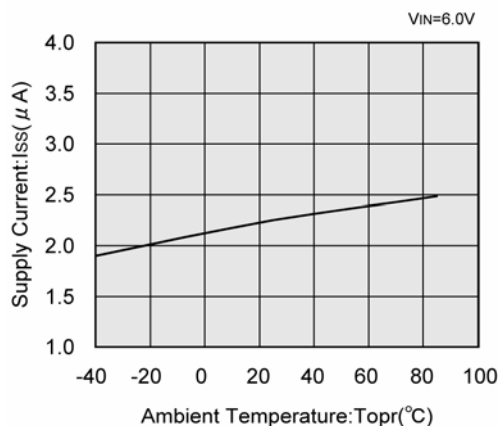

## TYPICAL PERFORMANCE CHARACTERISTICS (Continued)

### (7) Input Transient Response

XC6201P132

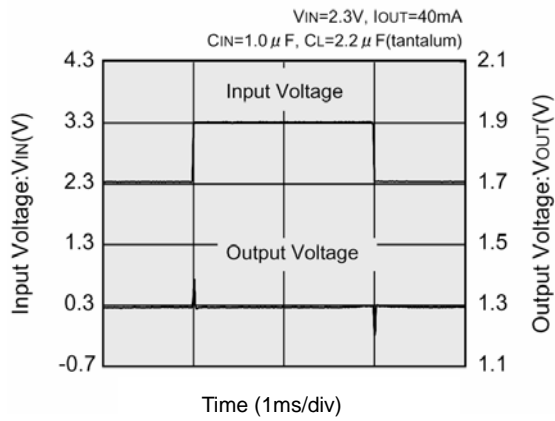

XC6201P182

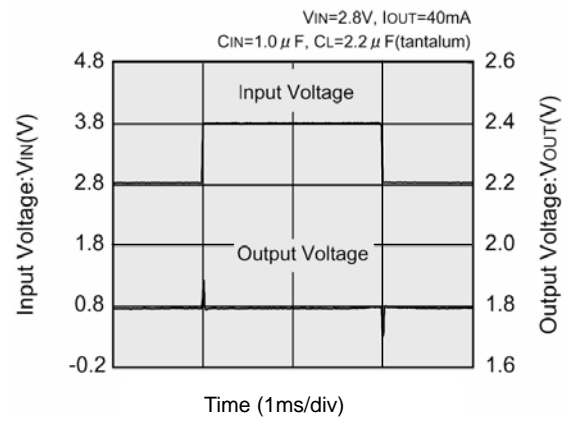

XC6201P272

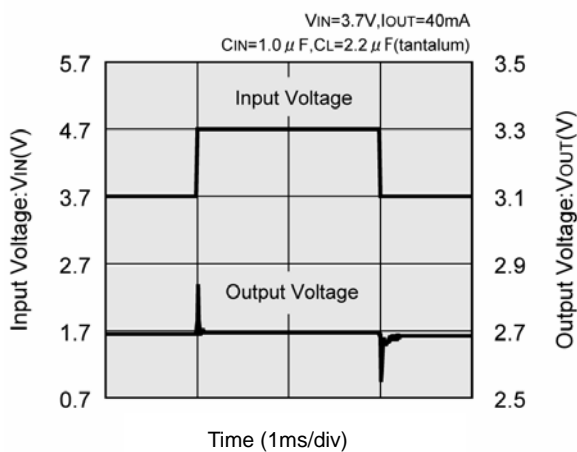

XC6201P332

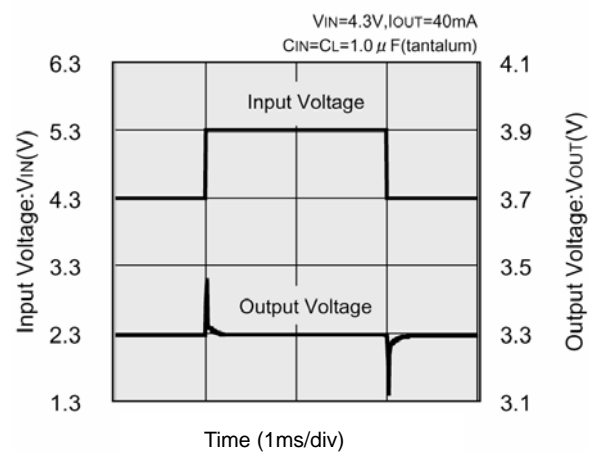

XC6201P502

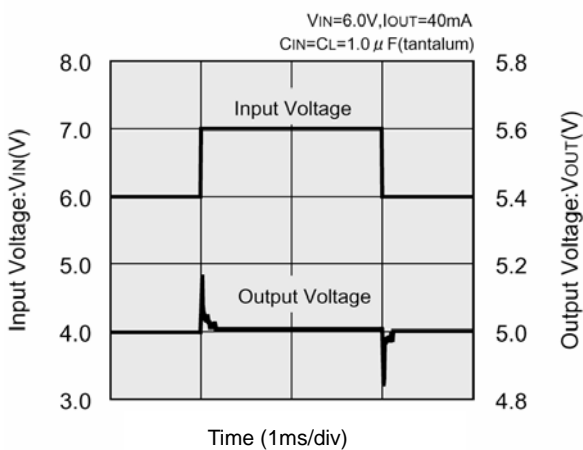



## TYPICAL PERFORMANCE CHARACTERISTICS (Continued)

### (8) Load Transient Response

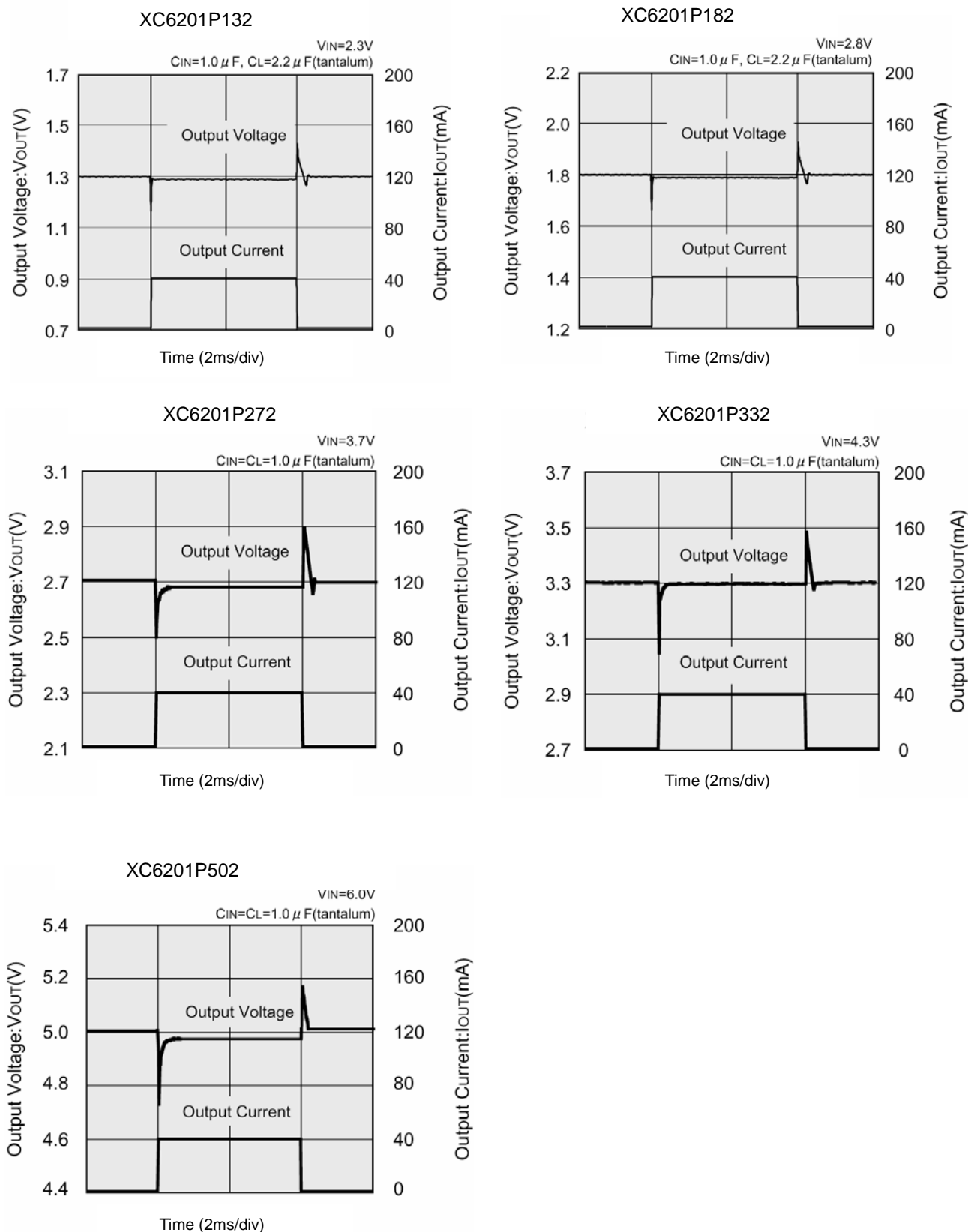

## TYPICAL PERFORMANCE CHARACTERISTICS (Continued)

### (9) Ripple Rejection Rate

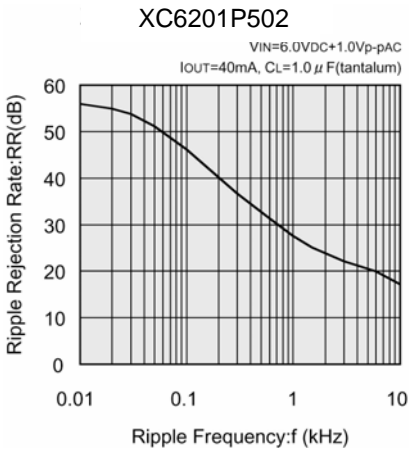
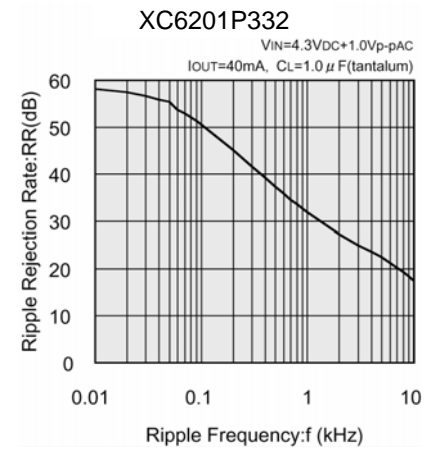
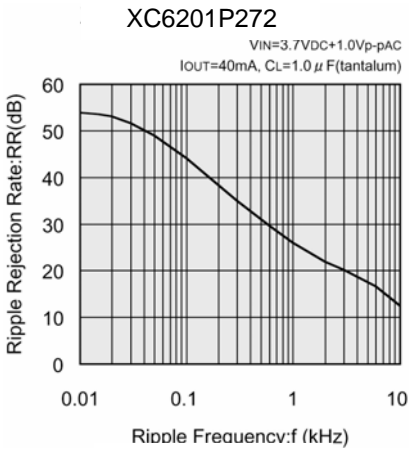
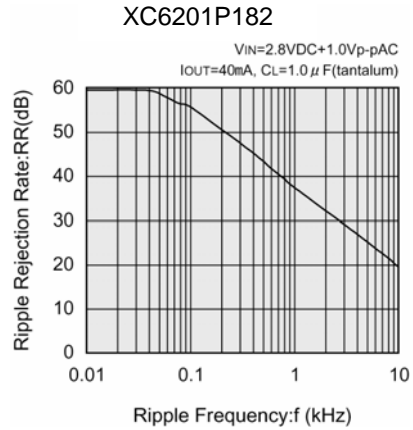
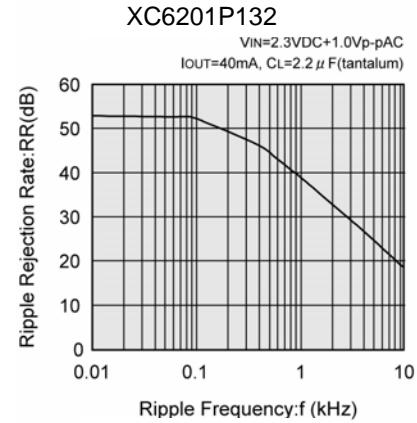

### (10) Output Noise Density

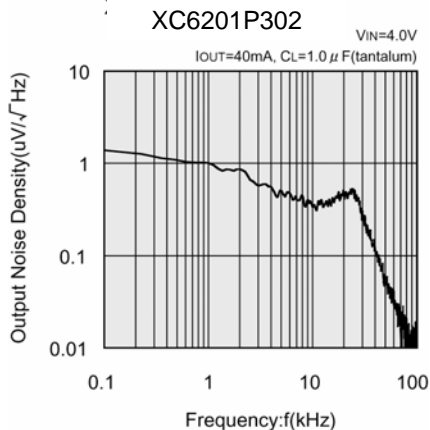

# PACKAGING INFORMATION

SOT-25

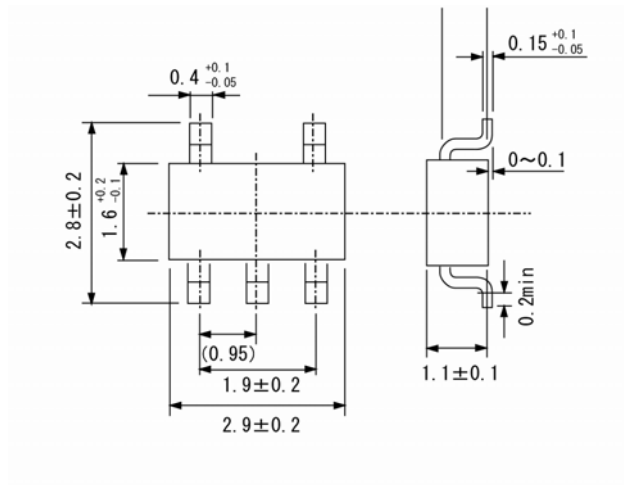

SOT-89

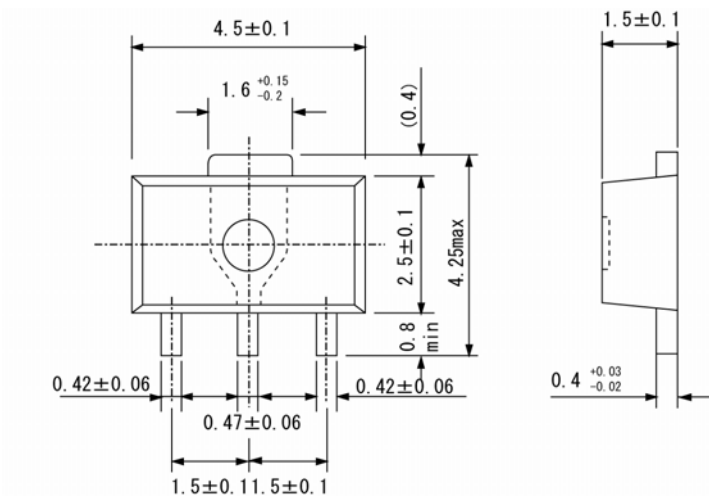

## PACKAGING INFORMATION (Continued)

TO-92

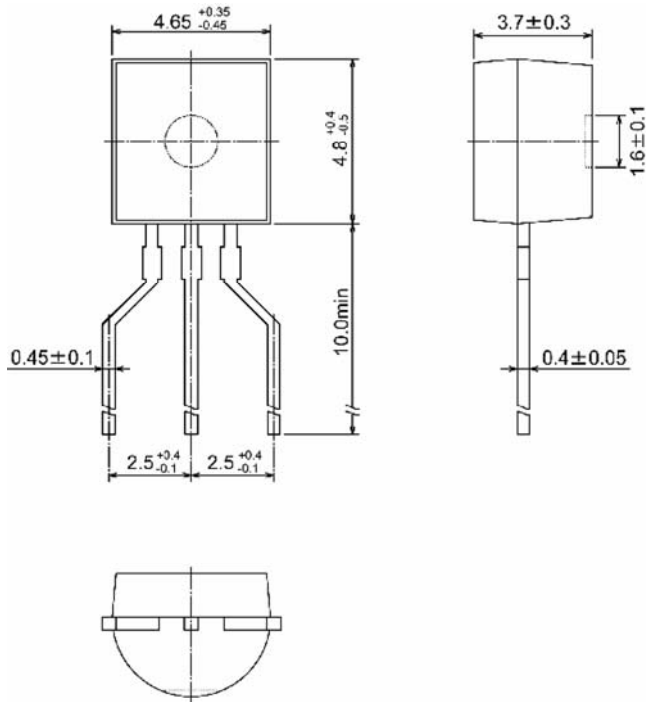

USP-6B

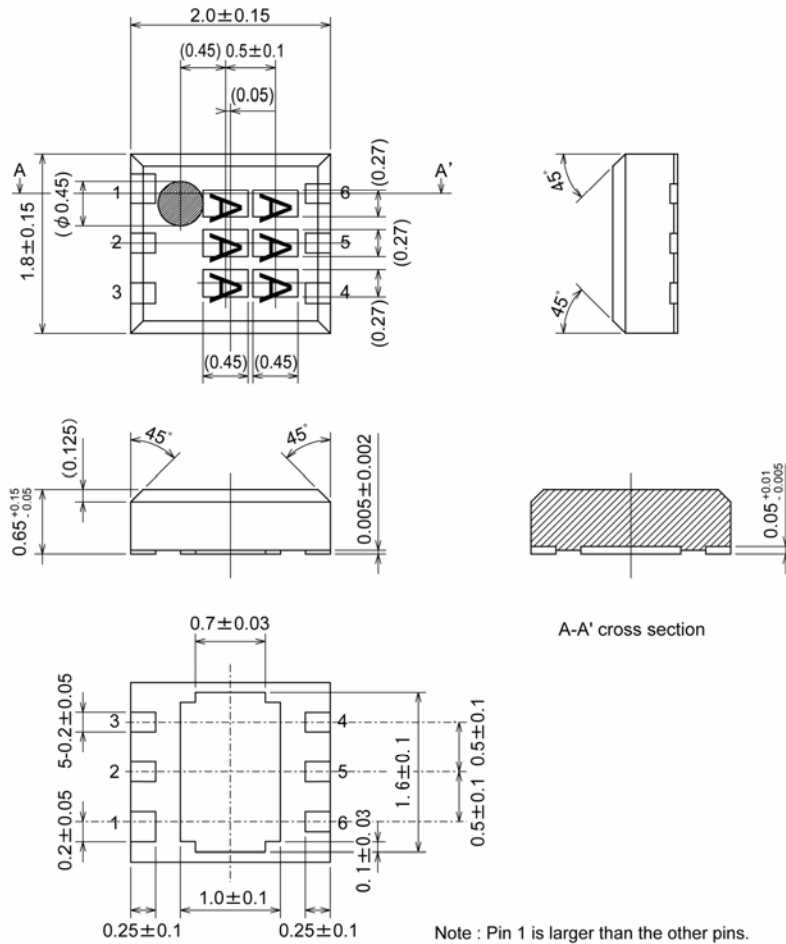

## PACKAGING INFORMATION (Continued)

USP-6B Recommended Pattern Layout

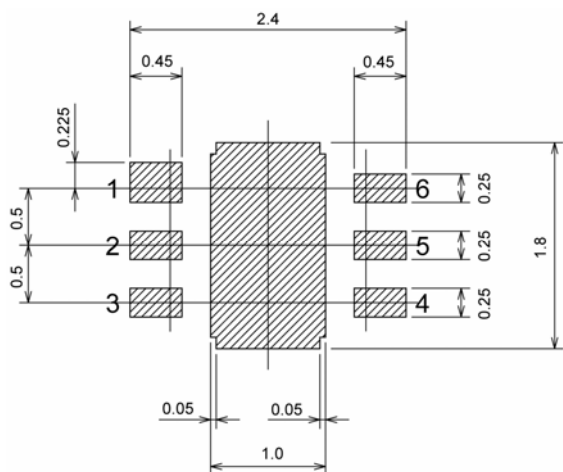

USP-6B Recommended Metal Mask Design

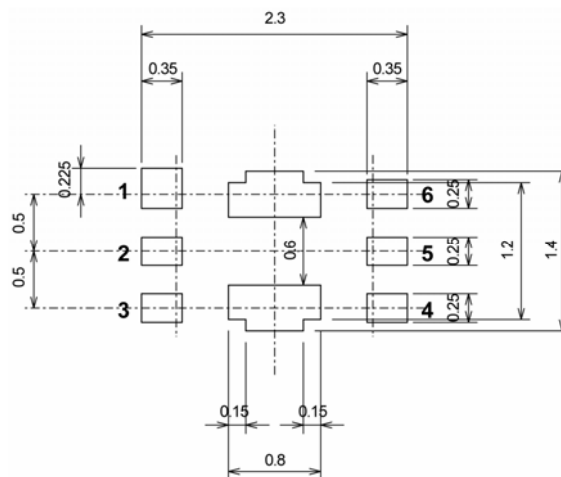

## MARKING RULE

SOT-89, SOT-25

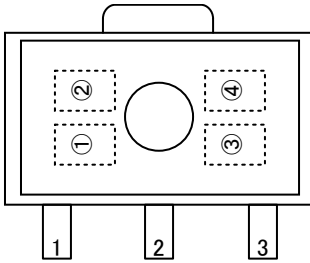

SOT-89  
(TOP VIEW)

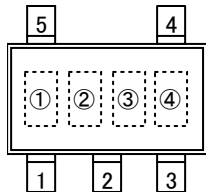

SOT-25  
(TOP VIEW)

Represents the product series

MARK	PRODUCT SERIES
1	XC6201Pxxxx

Represents type of regulator

MARK	VOLTAGE (V)
5	0.1 ~ 3.0
6	3.1 ~ 6.0

Represents output voltage

MARK	OUTPUT VOLTAGE (V)			MARK	OUTPUT VOLTAGE (V)		
0	-	3.1	-	F	1.6	4.6	-
1	-	3.2	-	H	1.7	4.7	-
2	-	3.3	-	K	1.8	4.8	-
3	-	3.4	-	L	1.9	4.9	-
4	-	3.5	-	M	2.0	5.0	-
5	-	3.6	-	N	2.1	5.1	-
6	-	3.7	-	P	2.2	5.2	-
7	-	3.8	-	R	2.3	5.3	-
8	-	3.9	-	S	2.4	5.4	-
9	-	4.0	-	T	2.5	5.5	-
A	-	4.1	-	U	2.6	5.6	-
B	-	4.2	-	V	2.7	5.7	-
C	1.3	4.3	-	X	2.8	5.8	-
D	1.4	4.4	-	Y	2.9	5.9	-
E	1.5	4.5	-	Z	3.0	6.0	-

Represents assembly lot number

0 to 9, A to Z repeated (G, I, J, O, Q, W excepted)

## MARKING RULE (Continued)

### TO-92

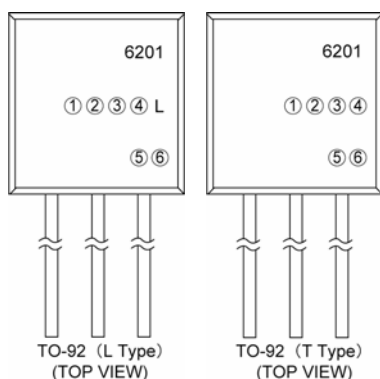

Represents type of regulator

MARK	PRODUCT SERIES
P	XC6201Pxxxx
T	XC6201Txxxx

Represents output voltage

MARK		VOLTAGE (V)	PRODUCT SERIES
3	3	3.3	XC6201Px33xx
5	0	5.0	XC6201Px50xx

Represents detect voltage accuracy

MARK	DETECT VOLTAGE ACCURACY	PRODUCT SERIES
1	Within $\pm 1\%$	XC6201Pxx1xx
2	Within $\pm 2\%$	XC6201Pxx2xx

Represents least significant digit of production year

MARK	PRODUCTION YEAR
3	2003
4	2004

Represents the production lot number

0 to 9, A to Z repeated (G, I, J, O, Q, W excepted)

Note: No character inversion used.

### USP-6B

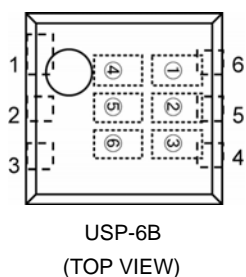

Represents product series

MARK		PRODUCT SERIES
0	1	XC6201xxxxDx

Represents type of regulator

MARK	TYPE	PRODUCT SERIES
P	3pin Regulator	XC6201PxxxDx
T	V <sub>IN</sub> =7V(Rated)	XC6201TxxxDx

Represents output voltage

MARK		VOLTAGE (V)	PRODUCT SERIES
3	3	3.3	XC6201x33xDx
5	0	5.0	XC6201x50xDx

Represents assembly lot number

0 to 9, A to Z repeated (G, I, J, O, Q, W excepted)

Note: No character inversion used.

1. The products and product specifications contained herein are subject to change without notice to improve performance characteristics. Consult us, or our representatives before use, to confirm that the information in this catalog is up to date.
2. We assume no responsibility for any infringement of patents, patent rights, or other rights arising from the use of any information and circuitry in this catalog.
3. Please ensure suitable shipping controls (including fail-safe designs and aging protection) are in force for equipment employing products listed in this catalog.
4. The products in this catalog are not developed, designed, or approved for use with such equipment whose failure of malfunction can be reasonably expected to directly endanger the life of, or cause significant injury to, the user.  
(e.g. Atomic energy; aerospace; transport; combustion and associated safety equipment thereof.)
5. Please use the products listed in this catalog within the specified ranges.  
Should you wish to use the products under conditions exceeding the specifications, please consult us or our representatives.
6. We assume no responsibility for damage or loss due to abnormal use.
7. All rights reserved. No part of this catalog may be copied or reproduced without the prior permission of Torex Semiconductor Ltd.

**TOREX SEMICONDUCTOR LTD.**