



JEWEL HILL ELECTRONIC CO.,LTD.

**SPECIFICATIONS FOR
LCD MODULE**

Module No. GG2048

Office Address: Rm. 518,5/F., 101 Shangbu Industrial District,
HuaqiangNorthRoad, Shenzhen, China

TEL : (86)-755-83362489 83617492

FAX: (86)-755-83286396 83365871

E-mail: sales@jewelhillelectronic.com
jlcd@21cn.com

Website: www.jewelhillelectronic.com

TABLE OF CONTENTS

LCM NUMBER SYSTEM	2
1. GENERAL DESCRIPTION	3
2. FEATURES.....	3
3. MECHANICAL SPECIFICATION	3
4. MECHANICAL DIMENSION	4
5. MAXIMUM RATINGS	5
6. ELECTRICAL CHARACTERISTICS	5
7. MODULE FUNCTION DESCRIPTION	6
8. ELECTRO-OPTICAL CHARACTERISTICS	14
9. RELIABILITY.....	18
10. PRECAUTIONS FOR USING LCD MODULES	19
11. USING LCD MODULES.....	21
12. REVISION HISTORY	23
SAMPLE APPROVED REPORT	24

LCM Number System

GG 2048 F W D S P F N F-V00-L Y C X

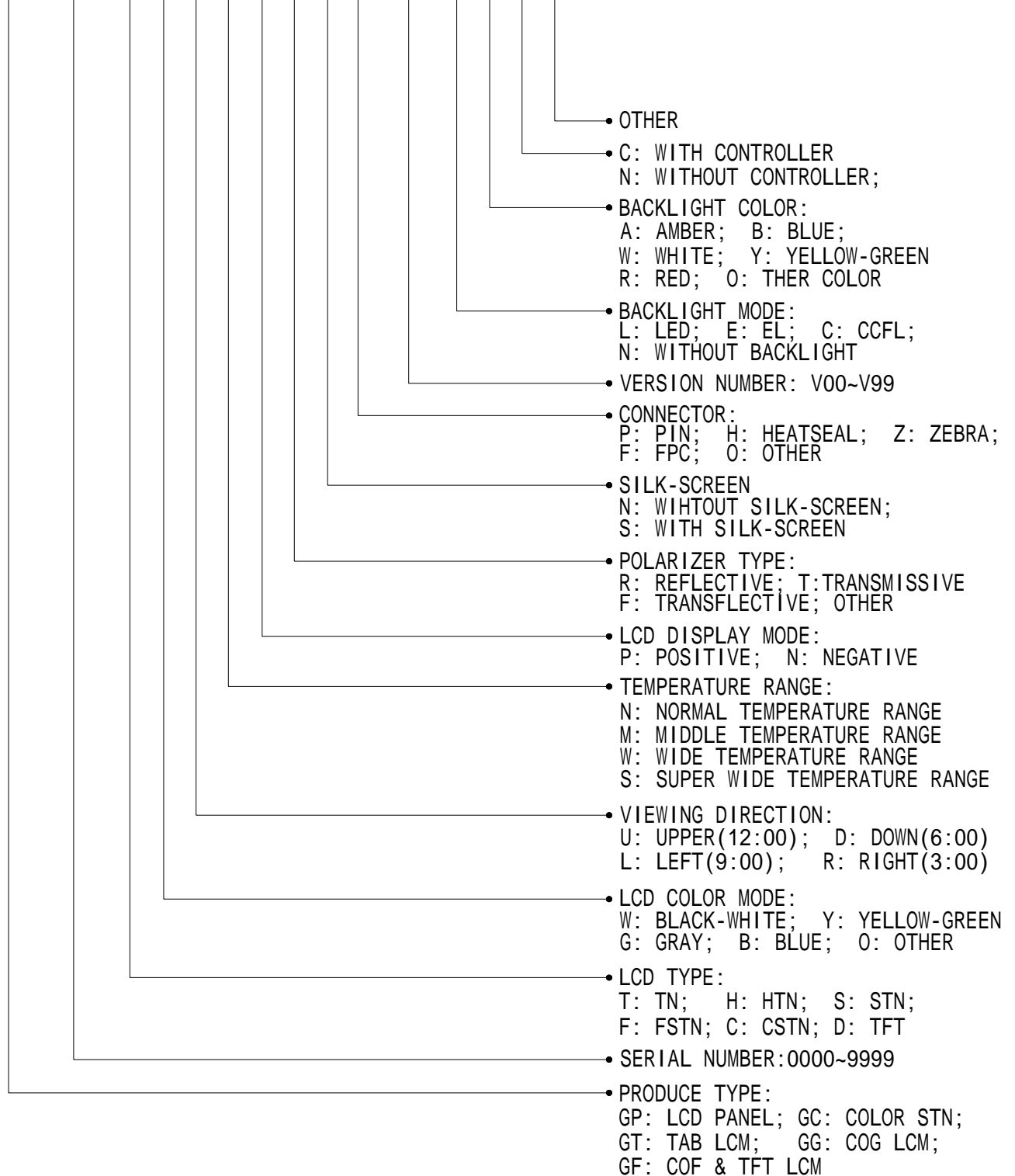

1. GENERAL DESCRIPTION

The GG2048 is a 128 x 32 Dots+Icon Graphic LCD module. It has a FSTN panel composed of 128 segments and 33 commons. The LCM can be easily accessed by microcontroller via parallel or series interface.

2. FEATURES

Display Mode	Transflective and positive
	FSTN module
Display Format	Graphic 128x32 dots+Icon
Input Data	8 bit parallel or Serial data input from MPU (Selection with PCB)
Multiplexing Ratio	1/65 Duty
Bias	1/9 Bias
Viewing Direction	6 O'clock
Controller LSI	SSD1815
Backlight	LED/Y-G

3. MECHANICAL SPECIFICATION

Item	Specifications	Unit
Dimensional outline	117.6 x (31.2+24.0) x 10.0(max)	mm
Resolution	128segs x 32coms+Icon	dots
Active area	Reference the Drawing in page4	mm
Dots pitch	Reference the Drawing in page4	mm
Dots size	Reference the Drawing in page4	mm

4. MECHANICAL DIMENSION

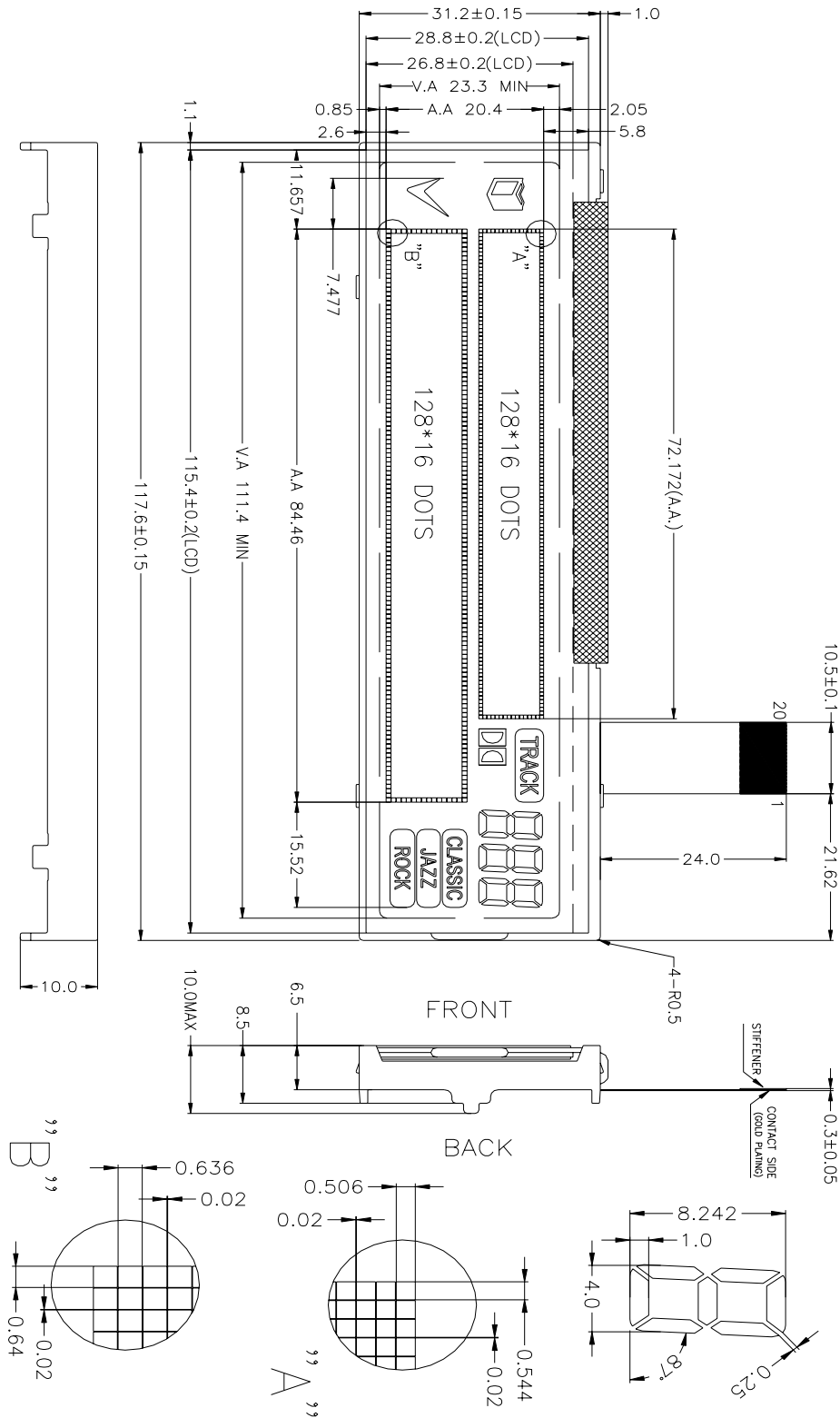

5. MAXIMUM RATINGS

Item	Symbol	Min	Max	Unit	Note
Supply voltage	$V_{DD} - V_{SS}$	-0.3	4.0	V	
	V_{LCD}	-0.3	18.0	V	
Input Voltage	V_{IN}	-0.3	$V_{DD}+0.3$	V	
Operating temperature	T_{OPR}	-20	+70	°C	
Storage temperature	T_{STR}	-30	+80	°C	
Humidity	---	---	90	%RH	

6. ELECTRICAL CHARACTERISTICS

Item		Symbol	Condition	Min.	Typ.	Max.	Unit
Supply Voltage	Logic	V_{DD}	---	---	3.0	---	V
Input Voltage	H level	V_{IH}	---	$0.8V_{DD}$	---	V_{DD}	V
	L level	V_{IL}		V_{SS}	---	$0.2V_{DD}$	
Current Consumption (LCD DRIVER)		I_{DD}	$V_{DD}=3.0V;$ $V_{LCD}=9.3V, T_{amb}=25^{\circ}C;$	---	---	2.0	mA
LCD Driving Voltage		V_{LCD}	Bias=1/7 $V_{LCD}=V_0-V_{SS}$	---	9.3	---	V
Current Consumption (WITH LED)		I_{LED}	$V_{DD}=3.0V;$ $V_{LED}=8.7V, T_{amb}=25^{\circ}C;$	---	---	TBD	mA

7. MODULE FUNCTION DESCRIPTION

7.1. PIN DESCRIPTION

Pin No.	Symbol	Description
1	/CS1	Chip Selection
2	/RES	Reset Signal Input
3	D/C	Date/Command Register Selection
4	NC/WR	No Connect(Serial Interface)/Write Signal(parallel Interface)
5	NC/E_RD	No Connect(Serial Interface)/Read Signal(parallel Interface)
6	NC/DB0	No Connect(Serial Interface)/Data Bus Low 5-bit(parallel Interface)
7	NC/DB1	
8	NC/DB2	
9	NC/DB3	
10	NC/DB4	
11	NC/DB5	
12	SCL/DB6	Serial Colok Input/Data Bus with bit6 for Parallel Interface
13	SDA/DB7	Serial Data Input/Data Bus with bit7 for Parallel Interface
14	VDD	Power Supply for Positive
15	NC	No Connect
16	VSS	Power Supply for Ground
17	NC/VR	No Connect/External Resistor Regulator Terminal
18	LED+	Power Supply for LED Positive
19	NC	No Connect
20	LED-	Power Supply for LED Negative

7.2 TIMING CHARACTERISTICS

1.SYSTEM BUS READ/WRITE CHARACTERISTIC

TABLE 3. 6800-Series MPU Parallel Interface Timing Characteristics ($V_{DD} - V_{SS} = 2.4$ to $3.5V$, $T_A = -30$ to $85^\circ C$)

Symbol	Parameter	Min	Typ	Max	Unit
t_{cycle}	Clock Cycle Time	300	-	-	ns
t_{AS}	Address Setup Time	0	-	-	ns
t_{AH}	Address Hold Time	0	-	-	ns
t_{DSW}	Write Data Setup Time	40	-	-	ns
t_{DHW}	Write Data Hold Time	15	-	-	ns
t_{DHR}	Read Data Hold Time	20	-	-	ns
t_{OH}	Output Disable Time	-	-	70	ns
t_{ACC}	Access Time	-	-	140	ns
PWCSL	Chip Select Low Pulse Width (read)	120	-	-	ns
	Chip Select Low Pulse Width (write)	60	-	-	ns
PWCSH	Chip Select High Pulse Width (read)	60	-	-	ns
	Chip Select High Pulse Width (write)	60	-	-	ns
t_R	Rise Time	-	-	15	ns
t_F	Fall Time	-	-	15	ns

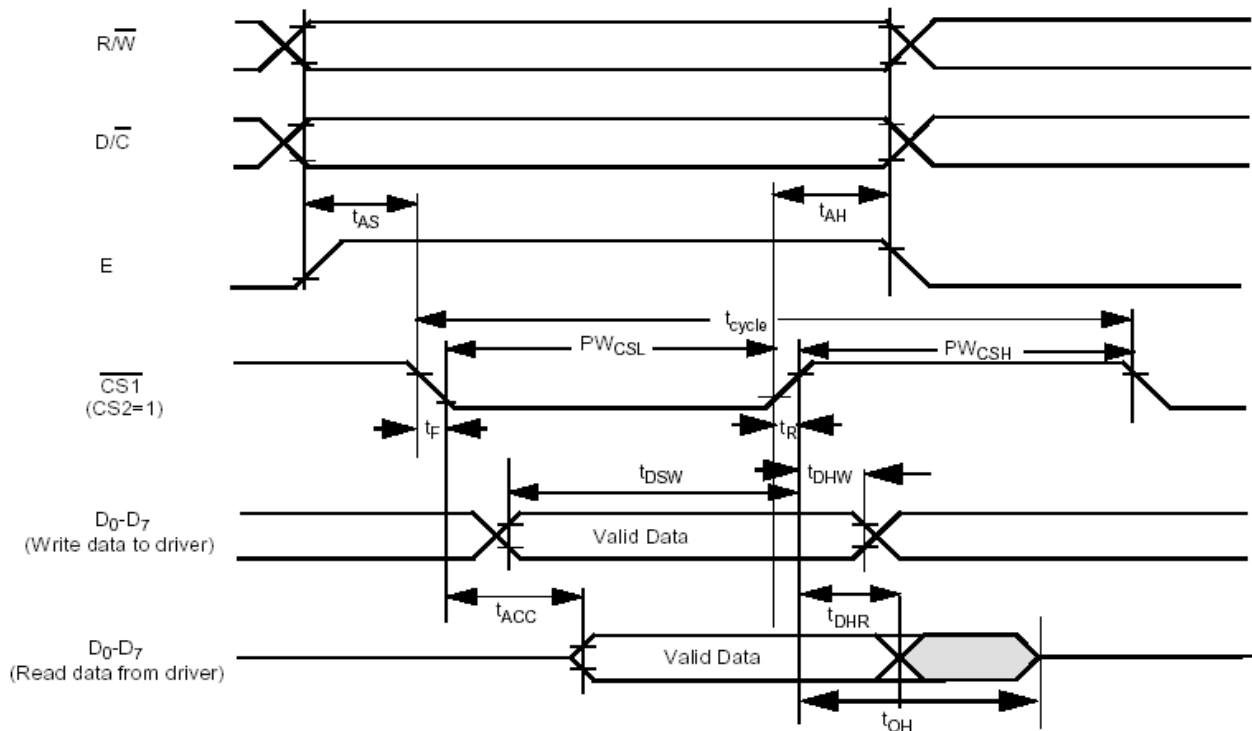

TABLE 4. 8080-Series MPU Parallel Interface Timing Characteristics ($V_{DD} - V_{SS} = 2.4$ to $3.5V$, $T_A = -30$ to $85^\circ C$)

Symbol	Parameter	Min	Typ	Max	Unit
t_{cycle}	Clock Cycle Time	300	-	-	ns
t_{AS}	Address Setup Time	0	-	-	ns
t_{AH}	Address Hold Time	0	-	-	ns
t_{DSW}	Write Data Setup Time	40	-	-	ns
t_{DHW}	Write Data Hold Time	15	-	-	ns
t_{DHR}	Read Data Hold Time	20	-	-	ns
t_{OH}	Output Disable Time	-	-	70	ns
t_{ACC}	Access Time	-	-	140	ns
PW _{CSL}	Chip Select Low Pulse Width (read)	120	-	-	ns
	Chip Select Low Pulse Width (write)	60	-	-	ns
PW _{CSH}	Chip Select High Pulse Width (read)	60	-	-	ns
	Chip Select High Pulse Width (write)	60	-	-	ns
t_R	Rise Time	-	-	15	ns
t_F	Fall Time	-	-	15	ns

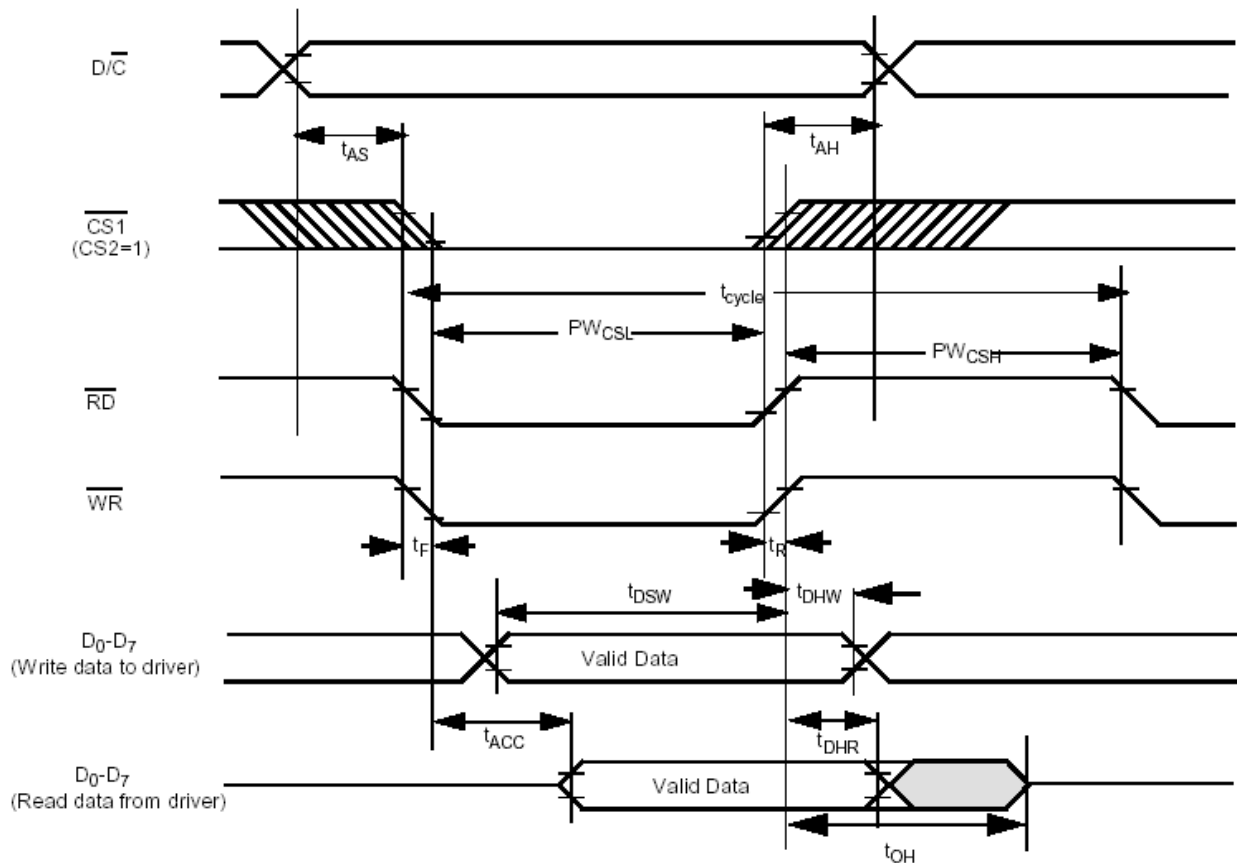
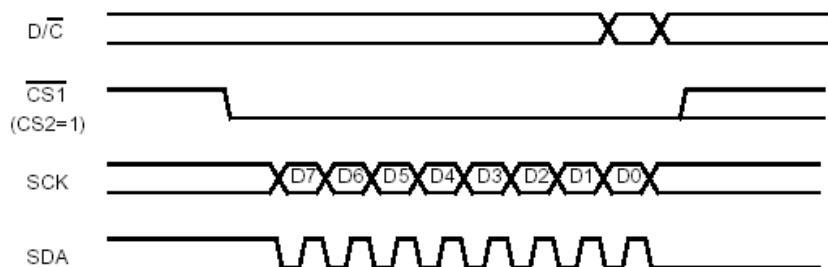
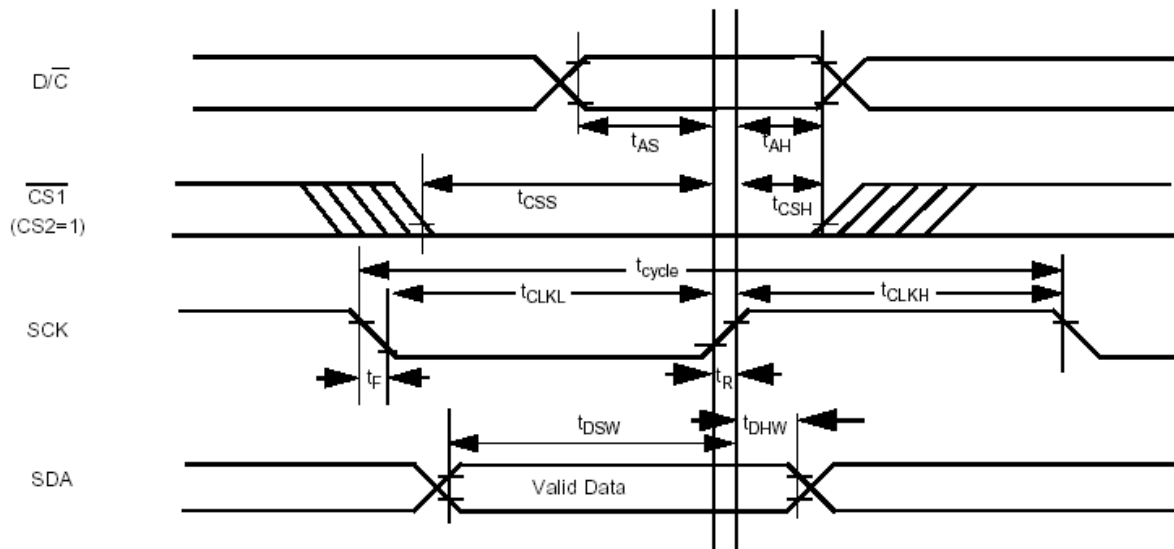

Figure 10 - 8080-series MPU Parallel Interface Characteristics

TABLE 5. Serial Interface Timing Characteristics ($V_{DD} - V_{SS} = 2.4$ to $3.5V$, $T_A = -30$ to $85^\circ C$)

Symbol	Parameter	Min	Typ	Max	Unit
t_{cycle}	Clock Cycle Time	250	-	-	ns
t_{AS}	Address Setup Time	150	-	-	ns
t_{AH}	Address Hold Time	150	-	-	ns
t_{CSS}	Chip Select Setup Time (for D_7 input)	120	-	-	ns
t_{CSH}	Chip Select Hold Time (for D_0 input)	60	-	-	ns
t_{DSW}	Write Data Setup Time	100	-	-	ns
t_{DHW}	Write Data Hold Time	100	-	-	ns
t_{CLKL}	Clock Low Time	100	-	-	ns
t_{CLKH}	Clock High Time	100	-	-	ns
t_R	Rise Time	-	-	15	ns
t_F	Fall Time	-	-	15	ns



7.3 BLOCK CIRCUIT

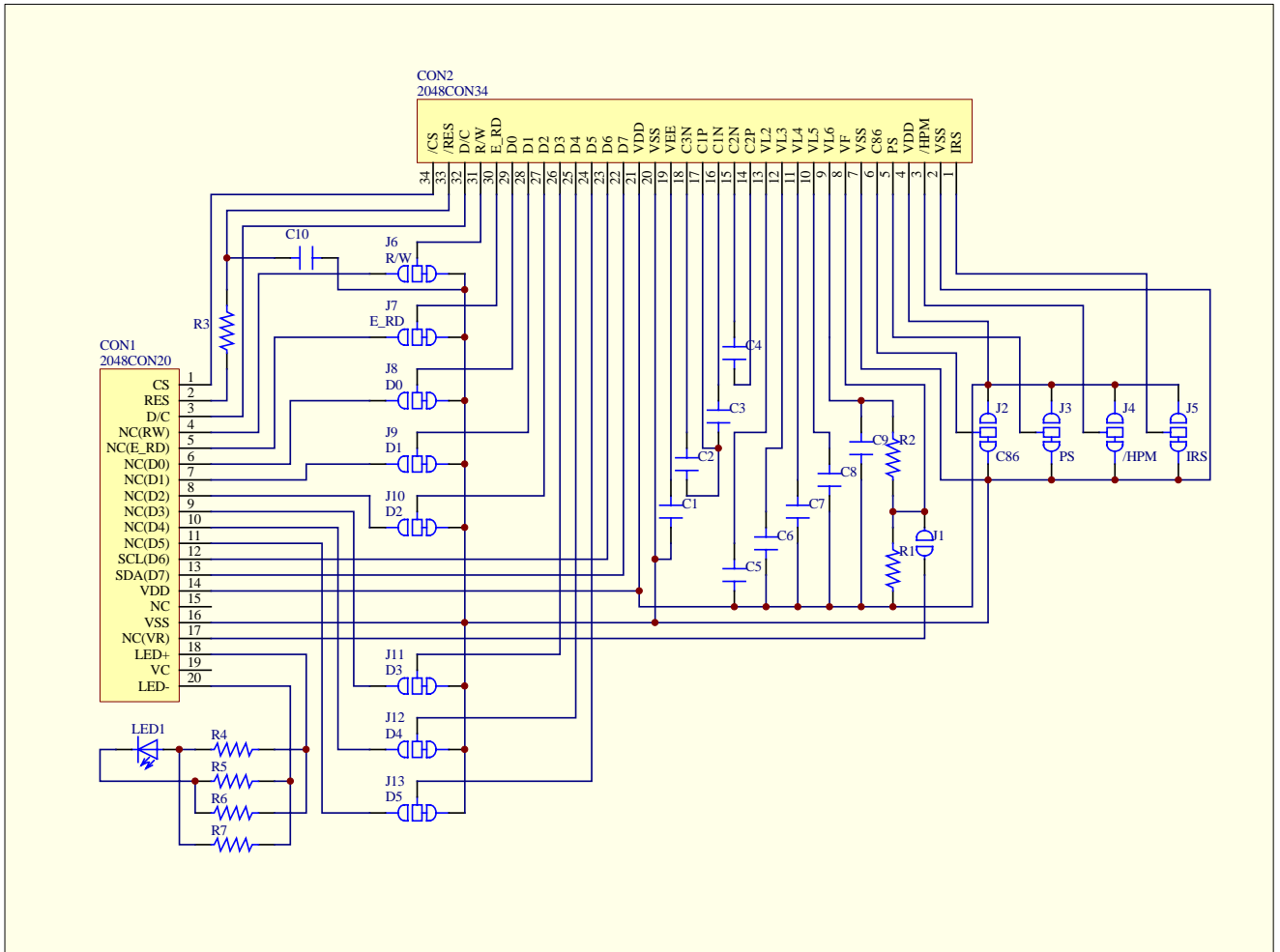

7.4 TABLE OF COMMAND



Bit Pattern	Write Command (D/C=0, R/W(WR)=0, E(RD)=1)	Comment
0000X ₃ X ₂ X ₁ X ₀	Set Lower Column Address	Set the lower nibble of the column address register using X ₃ X ₂ X ₁ X ₀ as data bits. The initial display line register is reset to 0000b during POR.
0001X ₃ X ₂ X ₁ X ₀	Set Higher Column Address	Set the higher nibble of the column address register using X ₃ X ₂ X ₁ X ₀ as data bits. The initial display line register is reset to 0000b during POR.
00100X ₂ X ₁ X ₀	Set Internal Regulator Resistor Ratio	Internal regulator gain increases as X ₂ X ₁ X ₀ increased from 000b to 111b. At POR, X ₂ X ₁ X ₀ = 100b.
00101X ₂ X ₁ X ₀	Set Power Control Register	X ₀ =0: turns off the output op-amp buffer (POR) X ₀ =1: turns on the output op-amp buffer X ₁ =0: turns off the internal regulator (POR) X ₁ =1: turns on the internal regulator X ₂ =0: turns off the internal voltage booster (POR) X ₂ =1: turns on the internal voltage booster
01X ₅ X ₄ X ₃ X ₂ X ₁ X ₀	Set Display Start Line	Set display RAM display start line register from 0-63 using X ₅ X ₄ X ₃ X ₂ X ₁ X ₀ . Display start line register is reset to 000000 during POR.
10000001 * * X ₅ X ₄ X ₃ X ₂ X ₁ X ₀	Set Contrast Control Register	Set Contrast level from 64 contrast steps. Contrast increases (V _{L6} decreases) as X ₅ X ₄ X ₃ X ₂ X ₁ X ₀ is increased. X ₅ X ₄ X ₃ X ₂ X ₁ X ₀ = 100000b (POR)
1010000X ₀	Set Segment Re-map	X ₀ =0: column address 00h is mapped to SEG0 (POR) X ₀ =1: column address 83h is mapped to SEG0 Refer to Figure 5 for example.
1010001X ₀	Set LCD Bias	X ₀ =0: 1/9 bias (POR) X ₀ =1: 1/7 bias For setting bias ratio to 1/4, 1/5, 1/6 or 1/8, see Extended Command Table.
1010010X ₀	Set Entire Display On/Off	X ₀ =0: normal display (POR) X ₀ =1: entire display on
1010011X ₀	Set Normal/Reverse Display	X ₀ =0: normal display (POR) X ₀ =1: reverse display
1010111X ₀	Set Display On/Off	X ₀ =0: turns off LCD panel (POR) X ₀ =1: turns on LCD panel
1011X ₃ X ₂ X ₁ X ₀	Set Page Address	Set GDDRAM Page Address (0-8) using X ₃ X ₂ X ₁ X ₀
1100X ₃ * * *	Set COM Output Scan Direction	X ₃ =0: normal mode (POR) X ₃ =1: remapped mode, COM0 to COM[N-1] becomes COM[N-1] to COM0 when Multiplex ratio is equal to N. See Figure 5 as an example for N equal to 64.
11100000	Set Read-Modify-Write Mode	Read-modify-write mode will be entered in which the column address will not be incremented during display data read. At POR, Read-modify-write mode is turned OFF.
11100010	Software Reset	Initialize the internal status register.
11101110	Set End of Read-Modify-Write Mode	Exit Read-modify-write mode. Column address before entering the mode will be restored. At POR, Read-modify-write mode is OFF.
1010110X ₀	Set Indicator On/Off	X ₀ = 0: indicator off (POR, no need of second command byte) X ₀ = 1: indicator on (second command byte required)
* * * * * X ₁ X ₀	Indicator Display Mode, This second byte command is required ONLY when "Set Indicator On" command is sent.	X ₁ X ₀ = 00: indicator off X ₁ X ₀ = 01: indicator on and blinking at ~1 second interval X ₁ X ₀ = 10: indicator on and blinking at ~1/2 second interval X ₁ X ₀ = 11: Indicator on constantly
11100011	NOP	Command for No Operation
11110000	Test Mode Reset	Reserved for IC testing. Do NOT use.
1111 * * * *	Set Test Mode	Reserved for IC testing. Do NOT use.
* * * * * *	Set Power Save Mode	Standby or sleep mode will be entered with compound commands



Bit Pattern	Read Command (D/C=0, R/W(WR)=1, E(RD)=0)	Comment
D ₇ D ₆ D ₅ D ₄ D ₃ D ₂ D ₁ D ₀ (Data Read Back from the driver)	Status Register Read	D ₇ =0: indicates an internal operation is completed. D ₇ =1: indicates an internal operation is in progress. D ₆ =0: indicates reverse segment mapping with column address D ₆ =1: indicates normal segment mapping with column address D ₅ =0: indicates the display is ON D ₅ =1: indicates the display is OFF D ₄ =0: initialization is not in progress D ₄ =1: initialization is in progress after RES or software reset D ₃ D ₂ D ₁ D ₀ = 1010, these 4-bit is fixed to 1010 which could be used to identify as Solomon Systech Device.

EXTENDED COMMAND TABLE

Bit Pattern	Command	Comment
10101000 00X ₅ X ₄ X ₃ X ₂ X ₁ X ₀	X ₅ X ₄ X ₃ X ₂ X ₁ X ₀ : Set Multiplex Ratio	To select multiplex ratio N from 2 to 65 [Included Icon Line]. N = X ₅ X ₄ X ₃ X ₂ X ₁ X ₀ + 2, eg. N = 111111b + 2 = 65 (POR)
10101001 X ₇ X ₆ X ₅ X ₄ X ₃ X ₂ X ₁ X ₀	X ₁ X ₀ : Set Bias Ratio X ₄ X ₃ X ₂ : Set TC Value X ₇ X ₆ X ₅ : Modify Osc. Freq.	X ₁ X ₀ = 00: 1/8, 1/6 X ₁ X ₀ = 01: 1/6, 1/5 X ₁ X ₀ = 10: 1/9, 1/7 (POR) X ₁ X ₀ = 11: Prohibited X ₄ X ₃ X ₂ = 000: -0.01%/C (TC0, POR) X ₄ X ₃ X ₂ = 010: -0.10%/C (TC2) X ₄ X ₃ X ₂ = 100: -0.18%/C (TC4) X ₄ X ₃ X ₂ = 111: -0.25%/C (TC7) X ₄ X ₃ X ₂ = 001, 011, 101, 110: Reserved Increase the value of X ₇ X ₆ X ₅ will increase the oscillator frequency and vice versa. This command is not recommended to be used. X ₇ X ₆ X ₅ = 011(POR)
1010101X ₀	X ₀ : Set 1/4 Bias Ratio	X ₀ = 0: use Normal Setting (POR) X ₀ = 1: fixed at 1/4 Bias
11010010 0X ₆ X ₅ 00010	X ₆ X ₅ : Set Total Frame Phases	The On/Off of the Static Icon is given by 3 phases/1 phase overlapping of the M and MSTAT signals. This command set how many phases of dividing the M/MSTAT signals for each frame. The more the phases, the less the overlapping and thus the lower the effective driving voltage. X ₆ X ₅ = 00: 3 phases X ₆ X ₅ = 01: 5 phases X ₆ X ₅ = 10: 7 phases (POR) X ₆ X ₅ = 11: 16 phases
11010011 00X ₅ X ₄ X ₃ X ₂ X ₁ X ₀	X ₅ X ₄ X ₃ X ₂ X ₁ X ₀ : Set Display Offset (for mux ratio has been set less than 64 only)	After POR, X ₅ X ₄ X ₃ X ₂ X ₁ X ₀ = 0 After setting mux ratio less than 64, data will be displayed at Center of matrix. See Table 1. To move display towards Row 0 by L, X ₅ X ₄ X ₃ X ₂ X ₁ X ₀ = L To move display away from Row 0 by L, X ₅ X ₄ X ₃ X ₂ X ₁ X ₀ = 64-L Note: max. value of L = (64 - display mux)/2

Note: Patterns other than that given in Command Table and Extended Command Table are prohibited to enter to the chip as a command. Otherwise, unexpected result will occurs.

8. ELECTRO-OPTICAL CHARACTERISTICS

Item	Symbol	Condition	Temp	Min	Typ.	Max	Units	Note
LCD driving voltage	V _{LCD}	$\theta = \phi = 0$	0°C	---	9.5	---	V	NOTE1
			25°C	9.0	9.3	9.6		
			50°C	---	9.1	---		
Response Time	Rise Time (Tr)	$\theta = \phi = 0$	0°C	---	---	--	msec	NOTE2
	Decay Time (Tf)			---	---	---		
	Rise Time (Tr)		25°C	---	225	340		
	Decay Time (Tf)			---	240	360		
	Rise Time (Tr)		50°C	---	---	--		
	Decay Time (Tf)			---	---	--		
Contrast Ratio	Cr	$\theta = \phi = 0$	25°C	5	10	---	---	NOTE4

Viewing Angle Range	$\theta (\phi = 0^\circ)$ (6'')	$\phi = 90^\circ$ (3'')	$\phi = 180^\circ$ (12'')	$\phi = 270^\circ$ (9'')	備註
$\theta (25^\circ\text{C})$ CR \geq 2	45	35	15	30	Deg NOTE3

● For panel only

• **Electro-Optical Characteristics Measuring Equipment(DMS501)**

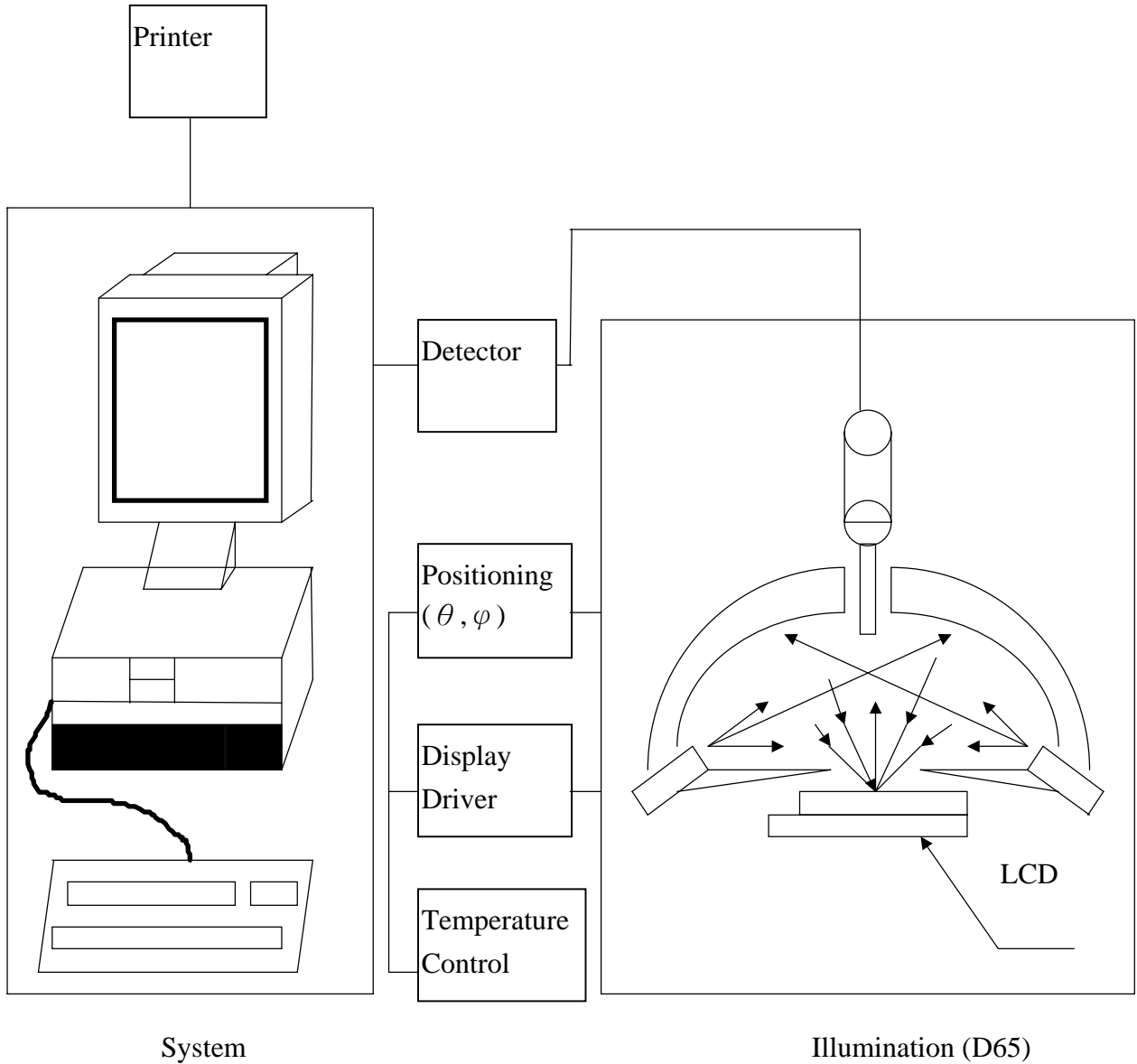

• **Note 1. Definition of Driving Voltage(V_{lcd}) :**

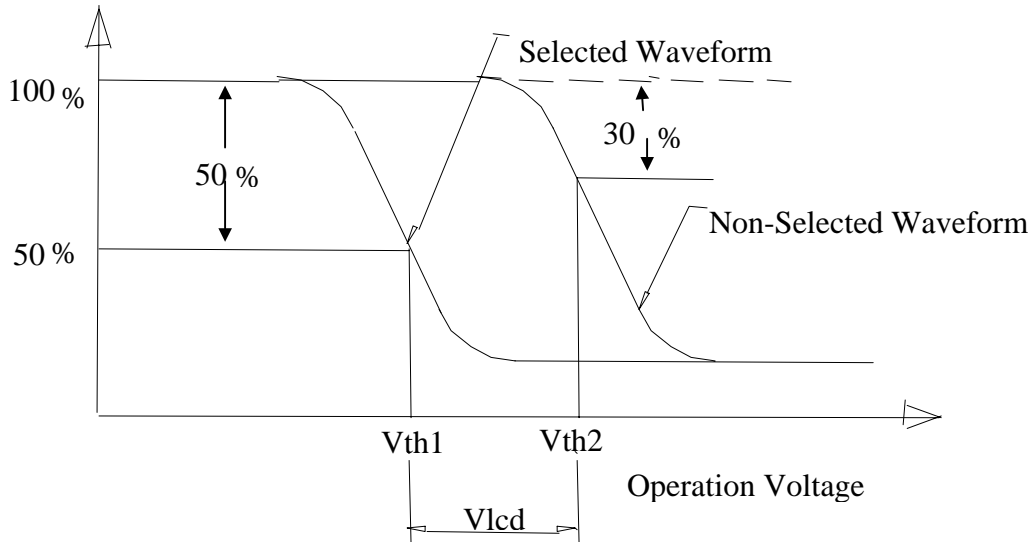

• **Note 2. Definition of Optical Response Time :**

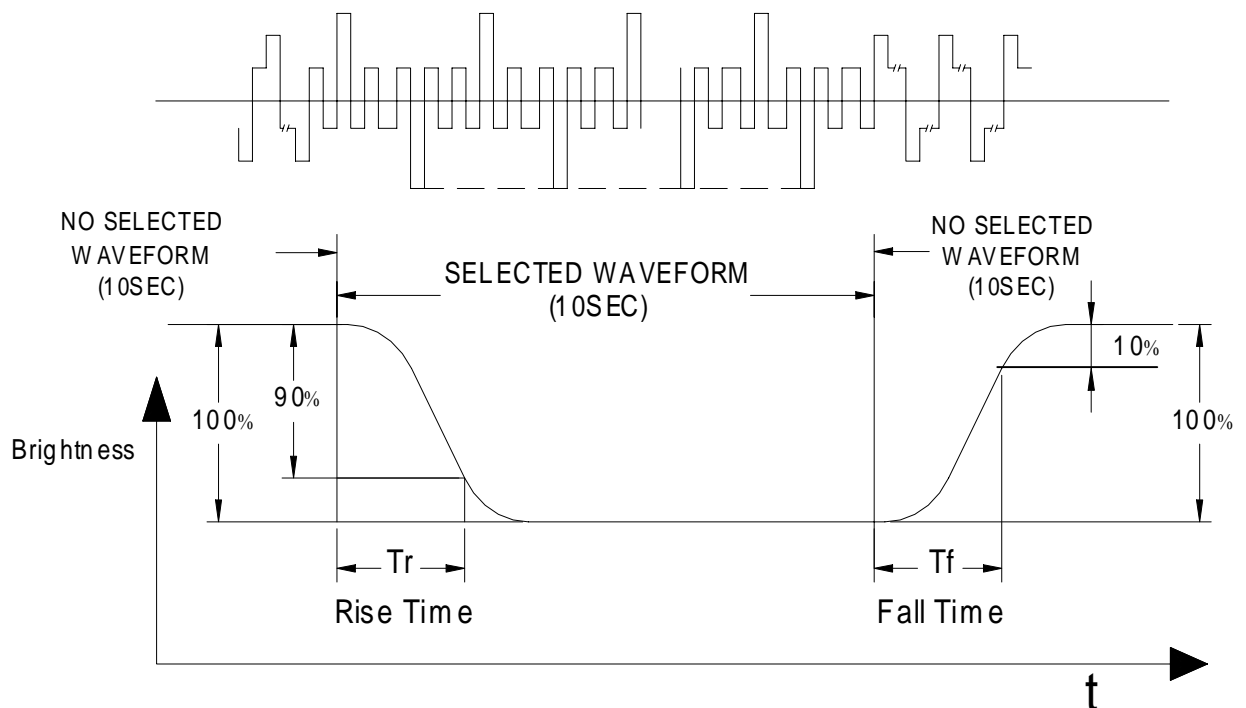

• **Note 3. Definition of Viewing Angle θ and ϕ :**

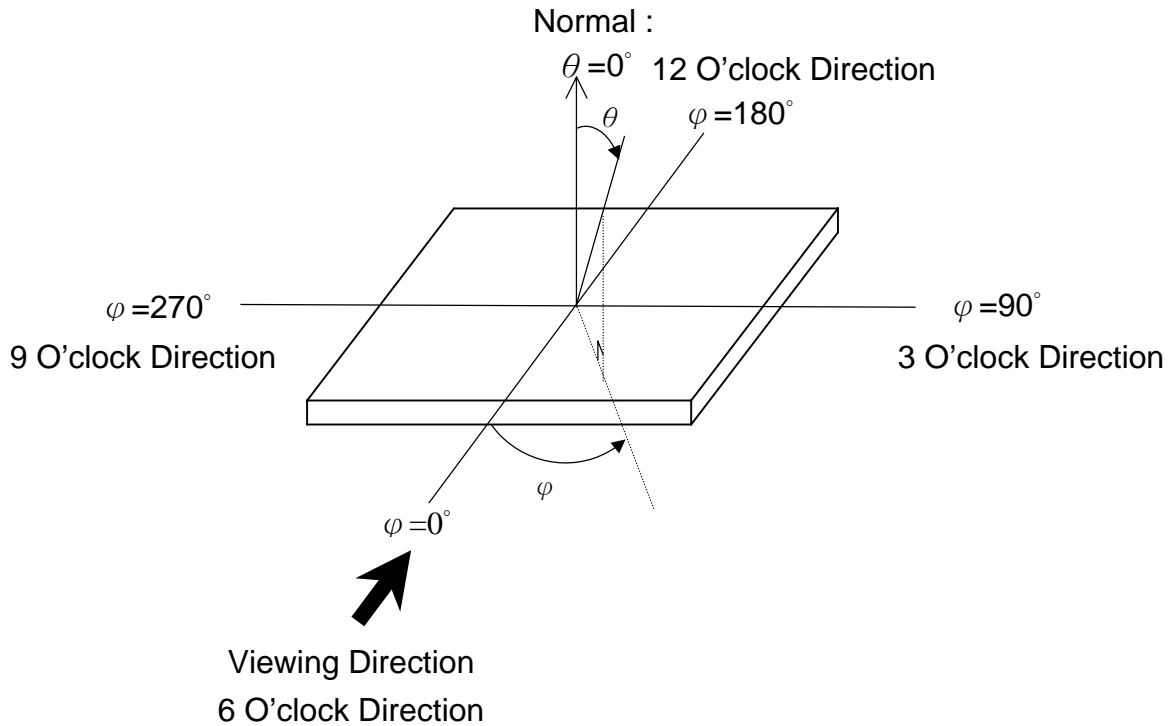

• **Note 4. Definition of Contrast ratio(CR) :**

$$CR = \frac{\text{Brightness of Non-selected Segment (B2)}}{\text{Brightness of Selected Segment (B1)}}$$

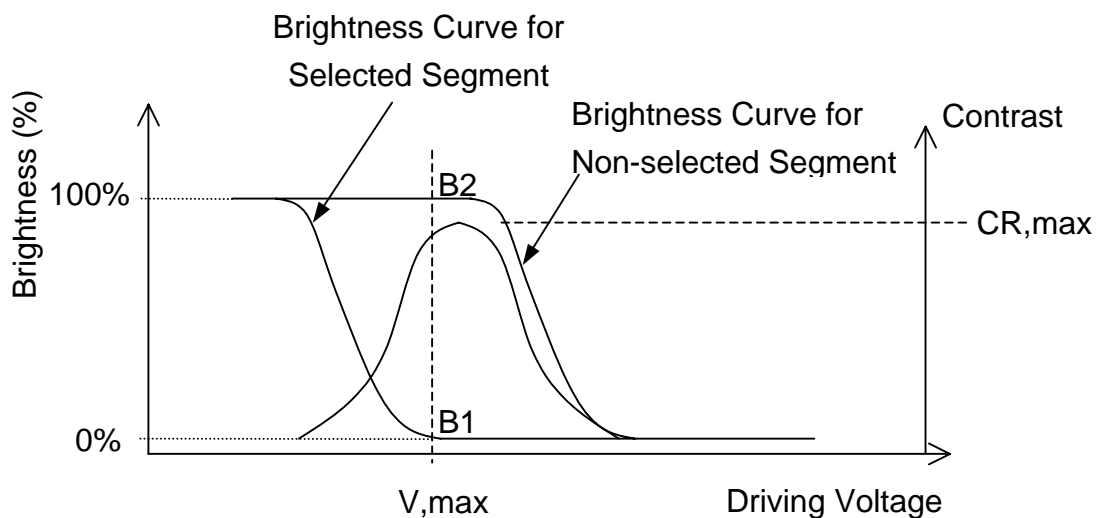

9. RELIABILITY

9.1. MTBF

The LCD module shall be designed to meet a minimum MTBF value of 50000 hours with normal. (25°C in the room without sunlight)

9.2. TESTS

NO.	ITEM	CONDITION	CRITERION
1	High Temperature Operating	70°C 120Hrs	<ul style="list-style-type: none"> ◦ No Defect Of Operational Function In Room Temperature Are Allowable. ◦ IDD of LCM in Pre-and post-test should follow specification
2	Low Temperature Operating	-20°C 120Hrs	
3	High Temperature/ Humidity Non-Operating	70°C ,90%RH ,120 Hrs	
4	High Temperature Non-Operating	80°C 120Hrs	
5	Low Temperature Non-Operating	-30°C 120Hrs	
6	Temperature Cycling Non-Operating	-20°C (30Min)↔ 60°C (30Min) 10 CYCLES	

Notes: Judgments should be made after exposure in room temperature for two hours.

10. PRECAUTIONS FOR USING LCD MODULES

10.1. HANDLING PRECAUTIONS

- (1) The display panel is made of glass. Do not subject it to a mechanical shock or impact by dropping it.
- (2) If the display panel is damaged and the liquid crystal substance leaks out, be sure not to get any in your mouth. If the substance contacts your skin or clothes, wash it off using soap and water.
- (3) Do not apply excessive force to the display surface or the adjoining areas since this may cause the color tone to vary.
- (4) The polarizer covering the display surface of the LCD module is soft and easily scratched. Handle this polarizer carefully.
- (5) If the display surface becomes contaminated, breathe on the surface and gently wipe it with a soft dry cloth. If it is heavily contaminated, moisten a cloth with one of the following solvents:
 - Isopropyl alcohol
 - Ethyl alcohol
- (6) Solvents other than those above mentioned may damage the polarizer.
Especially, do not use the following:
 - Water
 - Ketone
 - Aromatic solvents
- (7) Extra care to minimize corrosion of the electrode. Water droplets, moisture condensation or a current flow in a high-humidity environment accelerates corrosion of the electrode.
- (8) Install the LCD Module by using the mounting holes. When mounting the LCD Module, make sure it is free of twisting, warping and distortion. In particular, do not forcibly pull or bend the I/O cable or the backlight cable.
- (9) Do not attempt to disassemble or process the LCD Module.
- (10) NC terminal should be open. Do not connect anything.
- (11) If the logic circuit power is off, do not apply the input signals.
- (12) To prevent destruction of the elements by static electricity, be careful to maintain an optimum work environment.
 - Be sure to ground the body when handling the LCD Module.
 - Tools required for assembling, such as soldering irons, must be properly grounded.
 - To reduce the amount of static electricity generated, do not conduct assembling and other work under dry conditions.

-The LCD Module is coated with a film to protect the display surface. Exercise care when peeling off this protective film since static electricity may be generated.

10.2. STORAGE CONDITIONS

When storing, avoid the LCD module to be exposed to direct sunlight of fluorescent lamps. For stability, to keep it away from high temperature and high humidity environment (The best condition is : $23\pm 5^{\circ}\text{C}$, $45\pm 20\%\text{RH}$). ESD protection is necessary for long-term storage also.

10.3. OTHERS

Liquid crystals solidify under low temperature (below the storage temperature range) leading to defective orientation or the generation of air bubbles (black or white). Air bubbles may also be generated if the module is subject to a low temperature.

If the LCD Module have been operating for a long time showing the same display patterns the display patterns may remain on the screen as ghost images and a slight contrast irregularity may also appear. A normal operating status can be recovered by suspending use for some time. It should be noted that this phenomenon does not adversely affect performance reliability.

To minimize the performance degradation of the LCD Module resulting from destruction caused by static electricity etc. exercise care to avoid holding the following sections when handling the modules.

- Exposed area of the printed circuit board.
- Terminal electrode sections.

11. Using LCD modules

11.1 LIQUID CRYSTAL DISPLAY MODULES

LCD is composed of glass and polarizer. Pay attention to the following items when handling.

- (1) Please keep the temperature within specified range for use and storage. Polarization degradation, bubble generation or polarizer peel-off may occur with high temperature and high humidity.
- (2) Do not touch, push or rub the exposed polarizers with anything harder than a HB pencil lead (glass, tweezers, etc).
- (3) N-hexane is recommended for cleaning the adhesives used to attach front/rear polarizers and reflectors made of organic substances, which will be damaged by chemicals such as acetone, toluene, toluene, ethanol and isopropyl alcohol.
- (4) When the display surface becomes dusty, wipe gently with absorbent cotton or other soft material like chamois soaked in petroleum ether. Do not scrub hard to avoid damaging the display surface.
- (5) Wipe off saliva or water drops immediately, contact with water over a long period of time may cause deformation or color fading.
- (6) Avoid contacting oil and fats.
- (7) Condensation on the surface and contact with terminals due to cold will damage, stain or polarizers. After products are tested at low temperature they must be warmed up in a container before coming is contacting with room temperature air.
- (8) Do not put or attach anything on the display area to avoid leaving marks on.
- (9) Do not touch the display with bare hands. This will stain the display area and degrade insulation between terminals (some cosmetics are determinate to the polarizers).
- (10) As glass is fragile, it tends to become or chipped during handling especially on the edges. Please avoid dropping or jarring.

11.2 INSTALLING LCD MODULE

Attend to the following items when installing the LCM.

- (1) Cover the surface with a transparent protective plate to protect the polarizer and LC cell.
- (2) When assembling the LCM into other equipment, the spacer to the bit between the LCM and the fitting plate should have enough height to avoid causing stress to the module surface, refer to the individual specifications for measurements. The measurement tolerance should be ± 0.1 mm.

11.3 ELECTRO-STATIC DISCHARGE CONTROL

Since this module uses a CMOS LSI, the same careful attention should be paid for electrostatic discharge as for an ordinary CMOS IC.

- (1) Make certain that you are grounded when handling LCM.
- (2) Before removing LCM from its packing case or incorporating it into a set, be sure the module and your body have the same electric potential.
- (3) When soldering the terminal of LCM, make certain the AC power source for the soldering iron does not leak.
- (4) When using an electric screwdriver to attach LCM, the screwdriver should be of ground potentiality to minimize as much as possible any transmission of electromagnetic waves produced sparks coming from the commutator of the motor.
- (5) As far as possible, make the electric potential of your work clothes and that of the workbenches to the ground potential.
- (6) To reduce the generation of electro-static discharge, be careful that the air in the work is not too dried. A relative humidity of 50%-60% is recommended.

11.4 PRECAUTIONS FOR OPERATION

- (1) Viewing angle varies with the change of liquid crystal driving voltage (V_o). Adjust V_o to show the best contrast.
- (2) Driving the LCD in the voltage above the limit will shorten its lifetime.
- (3) Response time is greatly delayed at temperature below the operating temperature range. However, this does not mean the LCD will be out of the order. It will recover when it returns to the specified temperature range.
- (4) If the display area is pushed hard during operation, the display will become abnormal. However, it will return to normal if it is turned off and then on.
- (5) Condensation on terminals can cause an electrochemical reaction disrupting the terminal circuit. Therefore, this product must be used and stored within the specified condition of $23\pm 5^{\circ}\text{C}$, $45\pm 20\% \text{RH}$.
- (6) When turning the power on, input each signal after the positive/negative voltage becomes stable.

11.5 SAFETY

- (1) It is recommended to crush damaged or unnecessary LCDs into pieces and wash them off with solvents such as acetone and ethanol, which should later be burned.
- (2) If any liquid leaks out of a damaged glass cell and comes in contact with the hands, wash off thoroughly with soap and water.

12. REVISION HISTORY

Version	Revise record	Date
1.0	Original version	05-01-01
2.0	Change specification format	05-11-21

SAMPLE APPROVED REPORT (样品确认单)

SAMPLE MODEL NO. (样品型号)	GG2048
SAMPLE SERIES NUMBER NO. (样品序号)	
SAMPLE QUANTITY (样品数量)	
COLOR/TYPE (底色/类型)	FSTN/POSITIVE
VIEWING DIRECTION (视角)	6:00
DRIVING METHOD (驱动参数)	1/33Duty, 1/7Bias
LOGIC VOLTAGE (IC 工作电压)	3.0V
LCD VOP (LCD 驱动电压)	9.3V
OPERATING TEMP. (操作温度)	-20~70
STORAGE TEMP. (储存温度)	-30~80
POLARIZER----FRONT (首偏光片)	TRANSMISSIVE
POLARIZER----BACK (后偏光片)	TRANSFLECTIVE
CONTROLLER/DRIVER IC(控制/驱动 IC)	SSD1815
BACKLIGHT COLOR/TYPE (背光源类型/颜色)	LED/Y-G
DRAWING REV/NO./QUANTITY (图纸版本/数量)	
SPECIFICATION (规格书 份数)	
REMARKS : (备注)	
WRIT BY : _____ DATE : _____ APROV BY : _____ DATE : _____	
CUSTOMER'S APPROVAL (客户确认) :	
1) FUNCTION (功能) : <input type="checkbox"/> OK <input type="checkbox"/> N.G.	
2) DRIVER CONDITION (驱动条件) : <input type="checkbox"/> OK <input type="checkbox"/> N.G.	
3) DISPLAY MODE (显示模式) : <input type="checkbox"/> OK <input type="checkbox"/> N.G.	
4) VIEWING ANGLE (视角) : <input type="checkbox"/> OK <input type="checkbox"/> N.G.	
5) BACKLIGHT (背光源) : <input type="checkbox"/> OK <input type="checkbox"/> N.G.	
6) DISPLAYING PATTERN (显示效果) : <input type="checkbox"/> OK <input type="checkbox"/> N.G.	
CUSTOMER'S CONCLUSIONS (客户意见) : _____	

CUSTOMER'S SIGNATURE (客户签名) : _____ DATE (日期) : _____	