

Precision Micropower Shunt Voltage Reference

■GENERAL DESCRIPTION

NJM2825 is a precision and low quiescent current shunt voltage reference.

Reference voltage form bandgap circuit has guaranteed the high accuracy of the $\pm 0.5\%$ with trimming. In addition the temperature drift of $10\text{ppm}/^\circ\text{C}$ typ. was actualized by the temperature compensating circuit. The reference voltage circuit operates by consumed low quiescent current of the $0.7\mu\text{A}$ for low power technology.

The Output capacitor is unnecessary by the phase compensating circuit which is built in. Tolerates capacitive loads, it is easy to use for application.

It is suitable for data converters, instrumentation, and other applications where precision reference is required.

■PACKAGE OUTLINE

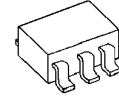

NJM2825F

■FEATURES

- Precision Reference Voltage $1,200\text{mV}\pm 0.5\%$
- Low temperature coefficient $10\text{ppm}/^\circ\text{C}$ typ.
- Low Quiescent Current $0.7\mu\text{A}$ max.
- No Output Capacitor Required
- Tolerates Capacitive Loads
- Bipolar Technology
- Package Outline NJM2825F : SOT-23-5 (MTP5)

■PRODUCT VARIATION

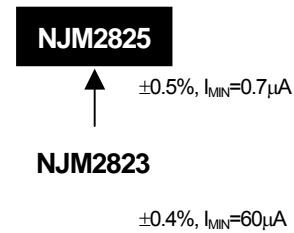

■BLOCK DIAGRAM

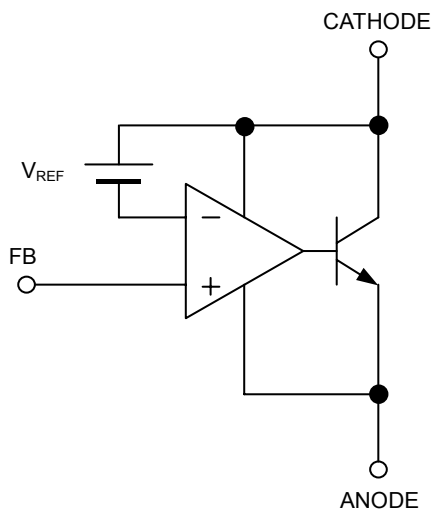

■PIN CONFIGURATION

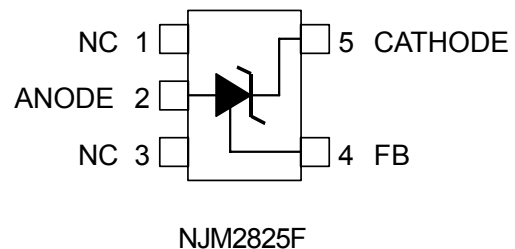

NJM2825

■ABSOLUTE MAXIMUM RATINGS (Ta=25°C)

PARAMETER	SYMBOL	MAXIMUM RATINGS	UNIT
Cathode Voltage	V_{KA}	14	V
Cathode Current	I_K	20	mA
Cathode-Anode Reverse Current	$-I_K$	10	mA
Power Dissipation	P_D	200	mW
Operating Temperature Range	T_{OPR}	-40 ~ +85	°C
Storage Temperature Range	T_{STG}	-40 ~ +125	°C

■RECOMMENDED OPERATING CONDITIONS (Ta=25°C)

PARAMETER	SYMBOL	MIN.	TYP.	MAX.	UNIT
Cathode Voltage	V_{KA}	V_{REF}	-	13	V
Cathode Current	I_K	0.7μ	-	12	mA

■ELECTRICAL CHARACTERISTICS ($I_K=0.8\mu A, T_a=25^\circ C$)

PARAMETER	SYMBOL	TEST CONDITION	MIN.	TYP.	MAX.	UNIT
Reference Voltage	V_{REF}	$V_{FB}=V_A$ (*1)	1194.0	1200.0	1206.0	mV
Load Regulation	$\frac{\Delta V_{REF}}{\Delta I_K}$	$V_{FB}=V_A, I_{MIN} \leq I_K \leq 200\mu A$ (*1)	-	0.2	0.7	mV
		$V_{FB}=V_A, 200\mu A \leq I_K \leq 2mA$ (*1)	-	0.7	2	mV
		$V_{FB}=V_A, 2mA \leq I_K \leq 12mA$ (*1)	-	3.4	10	mV
Reference Voltage Change vs. Cathode Voltage Change	$\frac{\Delta V_{REF}}{\Delta V_{KA}}$	$ V_{REF} \leq V_{KA} \leq 13V, I_K=2\mu A$ $R1=120k\Omega, R2=val$ (Note 1) (*2)	-	-1	-2	mV/V
Minimum Operating Current	I_{MIN}	$V_{REF} \leq V_{KA} \leq 5V$ (*2)	-	0.3	0.7	μA
		$5V \leq V_{KA} \leq 13V$ (*2)	-	1	2	μA
Feedback Current	I_{FB}	$R1=\infty, R2=120k\Omega$ (*2)	-	0.3	1	nA
Dynamic Impedance	$ Z_{KA} $	$V_{FB}=V_A, I_K=0.7\mu A \sim 12mA$ (*1)	-	0.4	1.1	Ω

■TEMPERATURE CHARACTERISTICS ($I_K=0.8\mu A, T_a=-40^\circ C \sim 85^\circ C$)

PARAMETER	SYMBOL	TEST CONDITION	MIN.	TYP.	MAX.	UNIT
Reference Voltage Change (Note 2)	ΔV_{REF_T}	$V_{FB}=V_A$ (*1)	-	0.8 10	2.3 30	mV ppm/°C
Reference Voltage (Note 2)	V_{REF_T}	$V_{FB}=V_A$ (*1)	1191.7	1200.0	1208.3	mV
Feedback Current Change	I_{FB_T}	$R1=\infty, R2=120k\Omega$ (*2)	-	0.4	-	nA

Note 1: $|V_{REF}|$...Reference voltage includes error.

Note 2: Reference Voltage Change is defined as

$$\Delta V_{REF_T} [mV] = \pm < \text{Reference Voltage Change [ppm/°C]} > \times < -40^\circ C \sim 25^\circ C > \times V_{REF}$$

The maximum value of "Reference Voltage Change" is determined based on sampling evaluation from the 5 initial production lots, and thus not tested in the production test. Therefore, these values are for the reference design purpose only.

(*1): Test Circuit (Fig.1)

(*2): Test Circuit (Fig.2)

TEST CIRCUIT

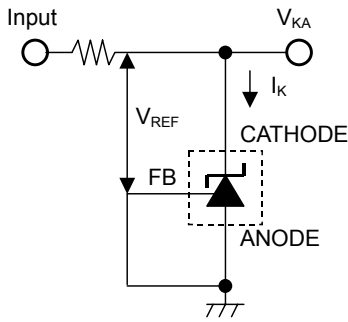

Fig.1 $V_{KA}=V_{REF}$ to test circuit

$$V_{FB}=V_A$$

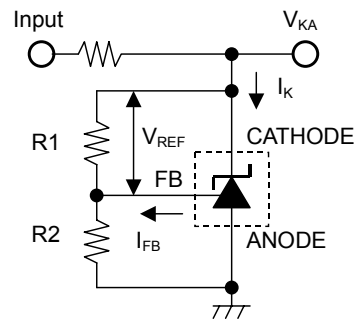
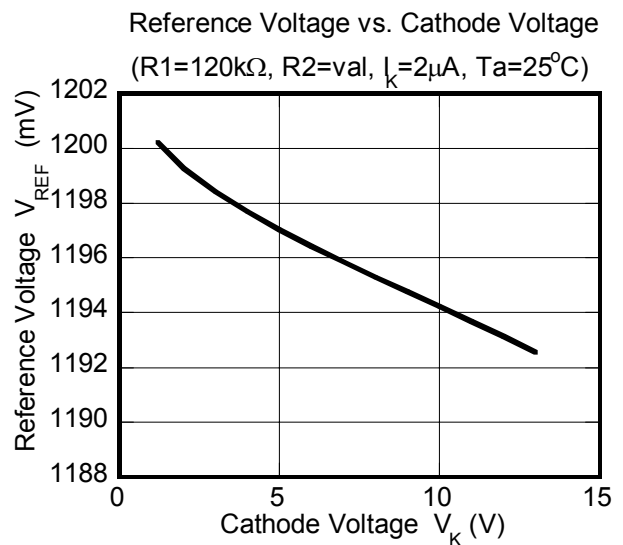
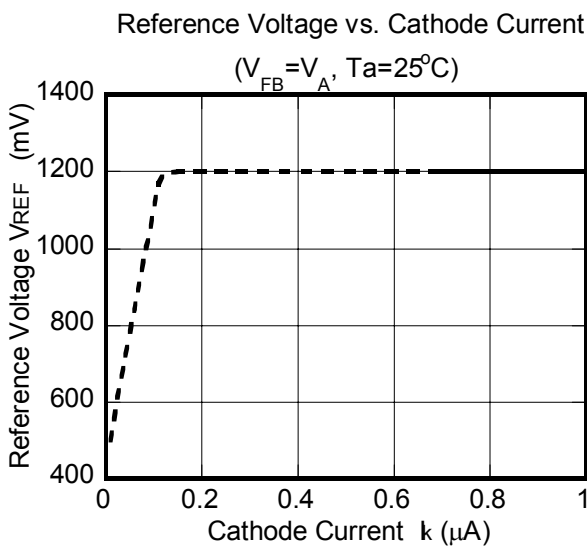
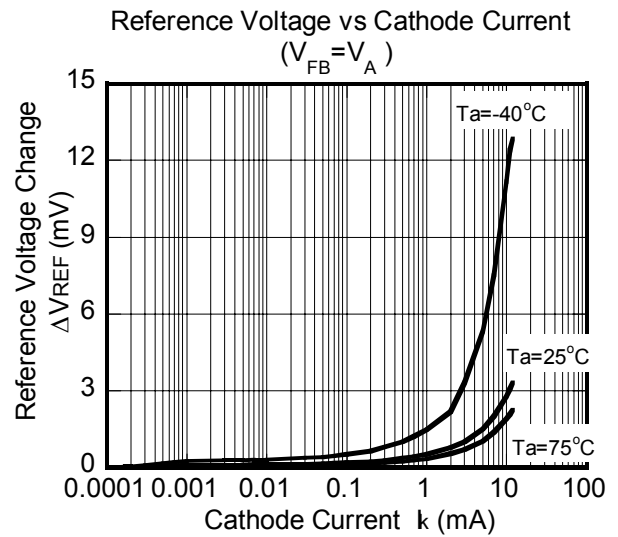
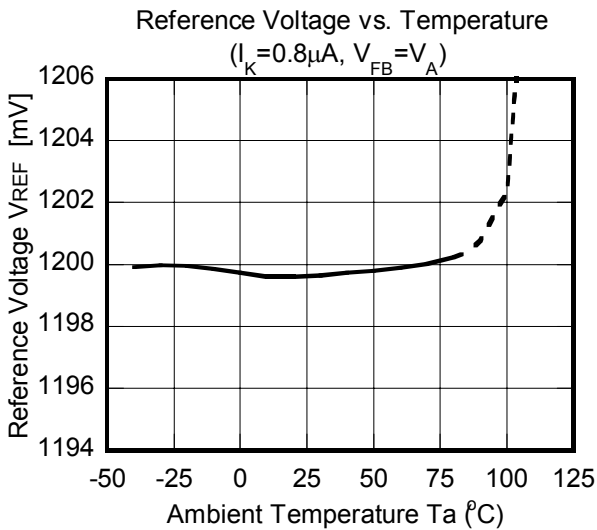

Fig.2 $V_{KA}>V_{REF}$ to test circuit

$$V_{KA} = V_{REF} \left(1 + \frac{R2}{R1} \right) + I_{FB} \times R2$$

TYPICAL CHARACTERISTICS



TYPICAL CHARACTERISTICS

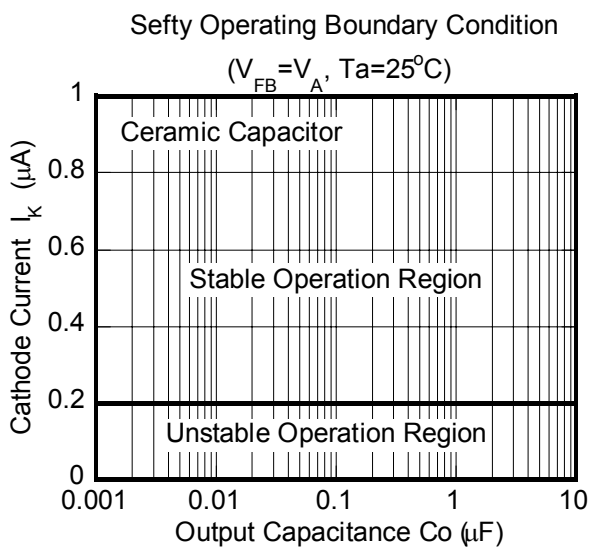
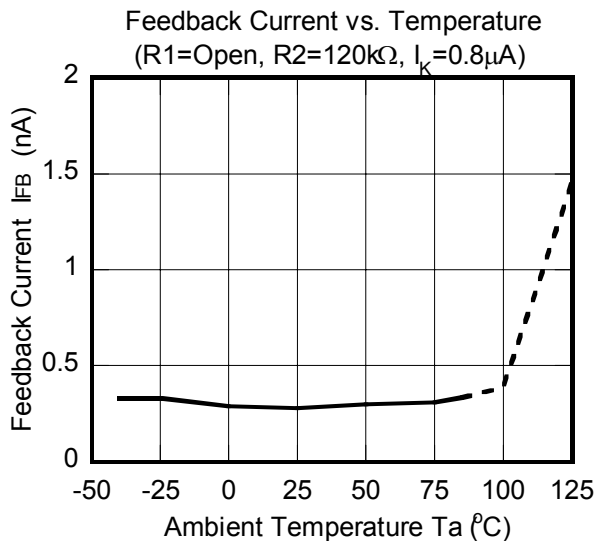
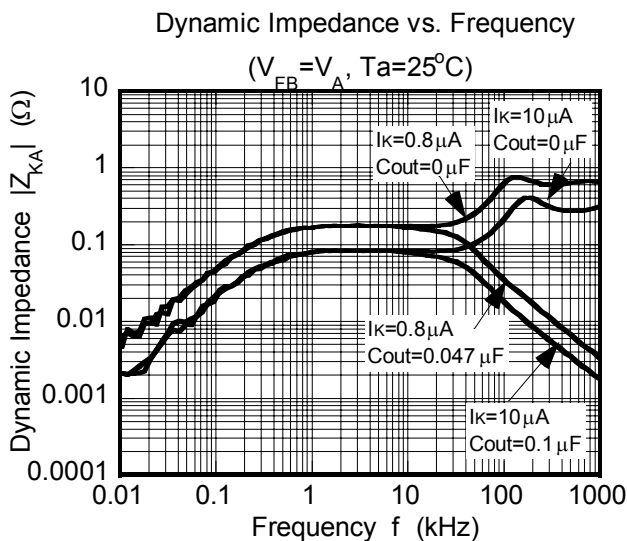

Note) Oscillation might occur while operating within the range of safety curve.
So that, it is necessary to make ample margins by taking considerations of fluctuation of the device.

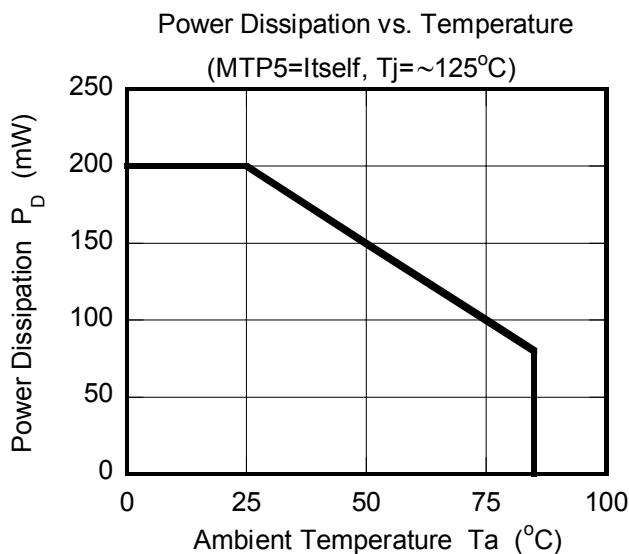

MEMO

[CAUTION]

The specifications on this databook are only given for information, without any guarantee as regards either mistakes or omissions. The application circuits in this databook are described only to show representative usages of the product and not intended for the guarantee or permission of any right including the industrial rights.