

SK 25 DGD 065 ET

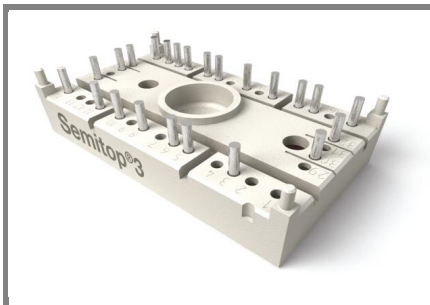

SEMITOP® 3

**3-phase bridge rectifier +
3-phase bridge inverter**

SK 25 DGD 065 ET

Preliminary Data

Features

- Compact design
- One screw mounting
- Heat transfer and isolation through direct copper bonded aluminium oxide ceramic (DCB)
- Ultrafast NPT technology IGBT
- CAL Technology FWD
- Integrated NTC temperature sensor

Typical Applications

- Inverter

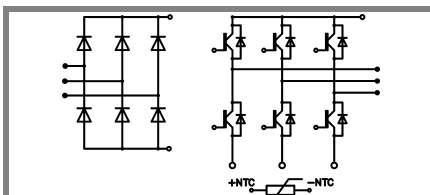

DGD - ET

Absolute Maximum Ratings		$T_s = 25^\circ\text{C}$, unless otherwise specified	
Symbol	Conditions	Values	Units
IGBT - Inverter, Chopper			
V_{CES}		600	V
I_C	$T_s = 25$ (80) $^\circ\text{C}$	30 (22)	A
I_{CRM}	$I_{CRM} = 2 \times I_{Cnom}$, $t_p = 1$ ms	60	A
V_{GES}		± 20	V
T_j		-40 ... +150	$^\circ\text{C}$
Diode - Inverter, Chopper			
I_F	$T_s = 25$ (80) $^\circ\text{C}$	36 (24)	A
I_{FRM}	$I_{FRM} = 2 \times I_{Fnom}$, $t_p = 1$ ms	70	A
T_j		-40 ... +150	$^\circ\text{C}$
Rectifier			
V_{RRM}		800	V
I_F	$T_s = 80$ $^\circ\text{C}$	35	A
I_{FSM} / I_{TSM}	$t_p = 10$ ms, sin 180° , $T_j = 25$ $^\circ\text{C}$	370	A
I_t^2	$t_p = 10$ ms, sin 180° , $T_j = 25$ $^\circ\text{C}$	685	A^2s
T_j		-40 ... +150	$^\circ\text{C}$
T_{sol}	Terminals, 10s	260	$^\circ\text{C}$
T_{stg}		-40 ... +125	$^\circ\text{C}$
V_{isol}	AC, 1 min. / 1s	2500 / 3000	V

Characteristics		$T_s = 25^\circ\text{C}$, unless otherwise specified			
Symbol	Conditions	min.	typ.	max.	Units
IGBT - Inverter, Chopper					
V_{CEsat}	$I_C = 20$ A, $T_j = 25$ (125) $^\circ\text{C}$		1,8 (2,1)	2 (2,2)	V
$V_{GE(th)}$	$V_{GE} = V_{CE}$, $I_C = 0,5$ mA	3	4	5	V
$V_{CE(TO)}$	$T_j = 25$ $^\circ\text{C}$ (125) $^\circ\text{C}$		1,2 (1,1)	1,3	V
r_T	$T_j = 25$ $^\circ\text{C}$ (125) $^\circ\text{C}$		40 (55)	60	m Ω
C_{ies}	$V_{CE} = V_{GE} = 0$ V, $f = 1$ MHz		1,6		nF
C_{oes}	$V_{CE} = V_{GE} = 0$ V, $f = 1$ MHz		-		nF
C_{res}	$V_{CE} = V_{GE} = 0$ V, $f = 1$ MHz		-		nF
$R_{th(j-s)}$	per IGBT			1,4	K/W
$t_{d(on)}$	under following conditions		30		ns
t_r	$V_{CC} = 300$ V, $V_{GE} = \pm 15$ V		25		ns
$t_{d(off)}$	$I_C = 25$ A, $T_j = 125$ $^\circ\text{C}$		250		ns
t_f	$R_{Gon} = R_{Goff} = 33$ Ω		15		ns
E_{on}	inductive load		0,8		mJ
E_{off}			0,55		mJ
Diode - Inverter, Chopper					
$V_F = V_{EC}$	$I_F = 25$ A, $T_j = 25$ (125) $^\circ\text{C}$		1,45 (1,4)	1,7 (1,75)	V
$V_{(TO)}$	$T_j = 25$ $^\circ\text{C}$ (125) $^\circ\text{C}$		(0,85)	(0,9)	V
r_T	$T_j = 25$ $^\circ\text{C}$ (125) $^\circ\text{C}$		(22)	(32)	m Ω
$R_{th(j-s)}$	per diode			1,7	K/W
I_{RRM}	under following conditions		-		A
Q_{rr}	$I_F = A$, $V_R = V$		-		μC
E_{rr}	$V_{GE} = 0$ V, $T_j = 125$ $^\circ\text{C}$ $di_F/dt = - A/\mu\text{s}$		-		mJ
Diode rectifier					
V_F	$I_F = 15$ A, $T_j = 25$ $^\circ\text{C}$		1,1		V
$V_{(TO)}$	$T_j = 150$ $^\circ\text{C}$		0,8		V
r_T	$T_j = 150$ $^\circ\text{C}$		15		m Ω
$R_{th(j-s)}$	per diode			1,7	K/W
Temperatur sensor					
R_{ts}	5 %, $T_r = 25$ (100) $^\circ\text{C}$		5000(493)		Ω
Mechanical data					
w			30		g
M_s	Mounting torque	2,3		2,5	Nm

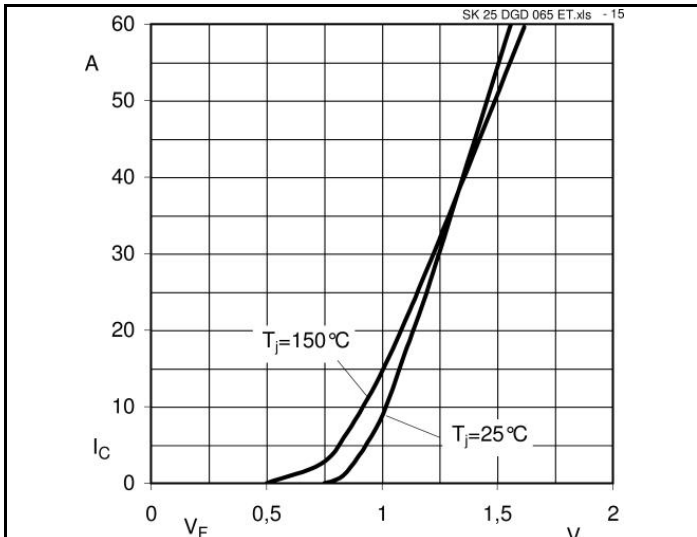

Fig. 15 Typ. Input Bridge Diode forward characteristic

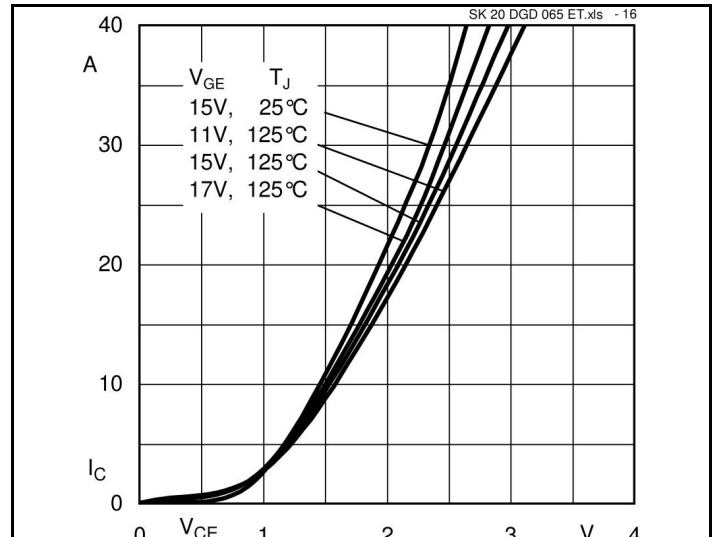

Fig. 16 Typical Output Characteristic

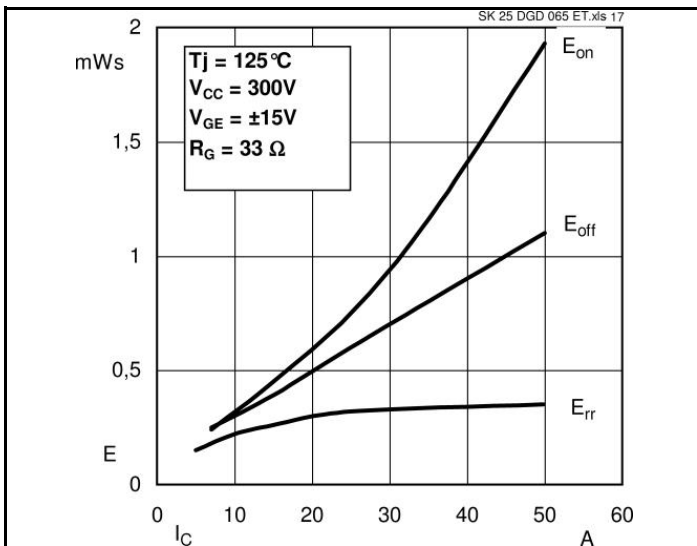

Fig. 17 Turn-On/Off Energy = $f(I_C)$

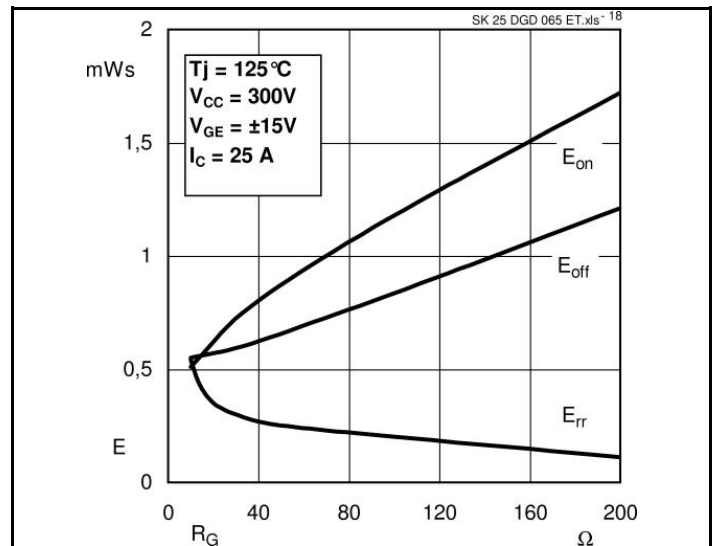

Fig. 18 Turn-On/Off Energy = $f(R_G)$

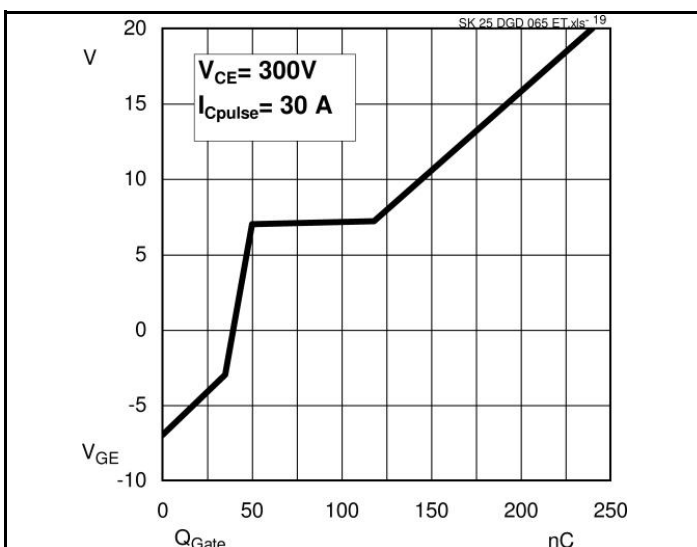

Fig. 19 Typical Gate Charge Characteristic

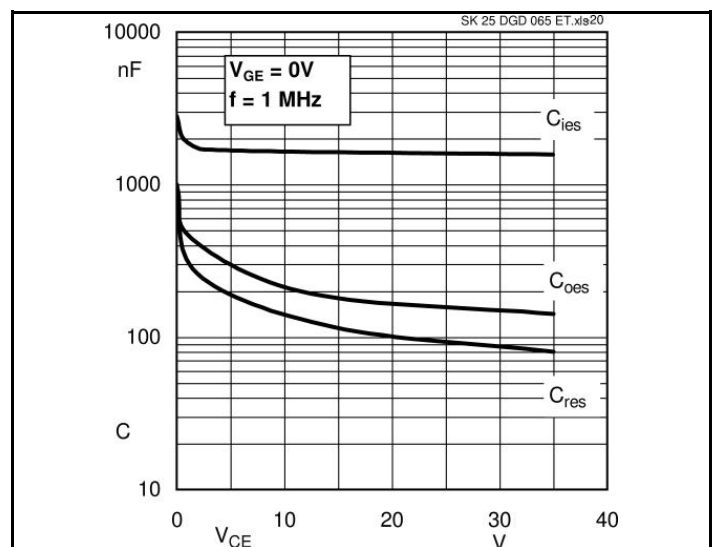
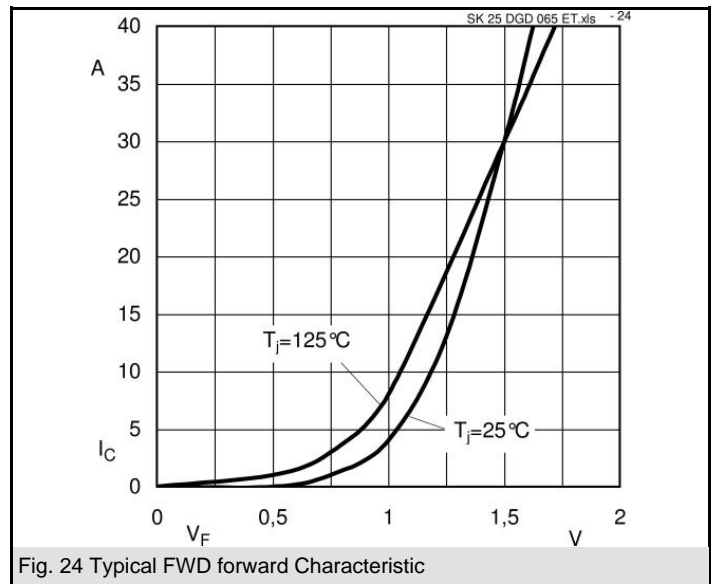
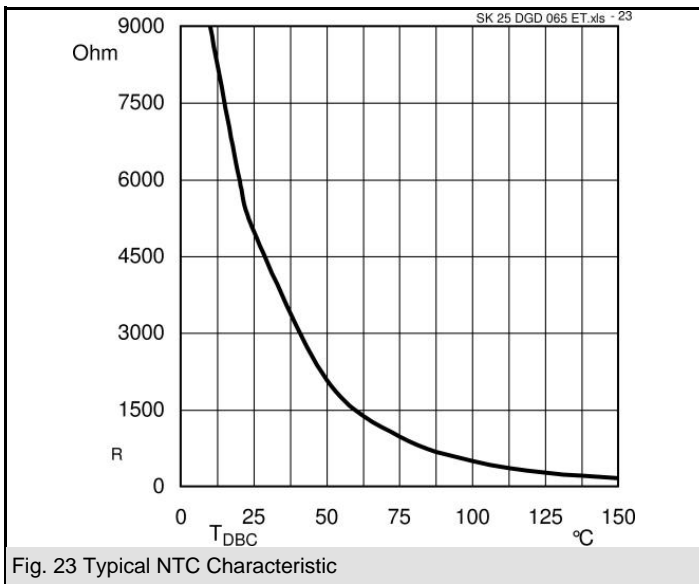
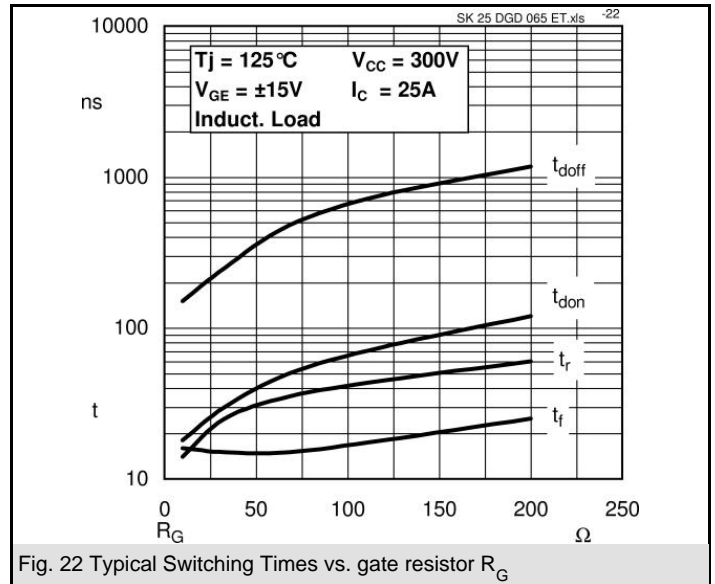
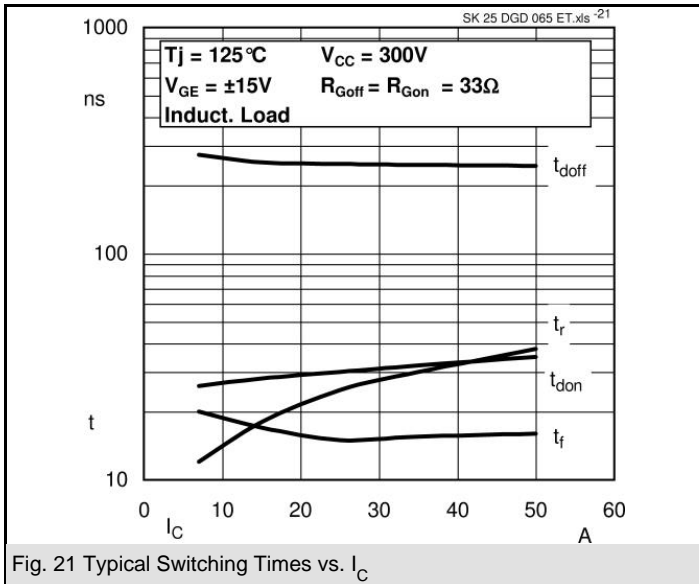
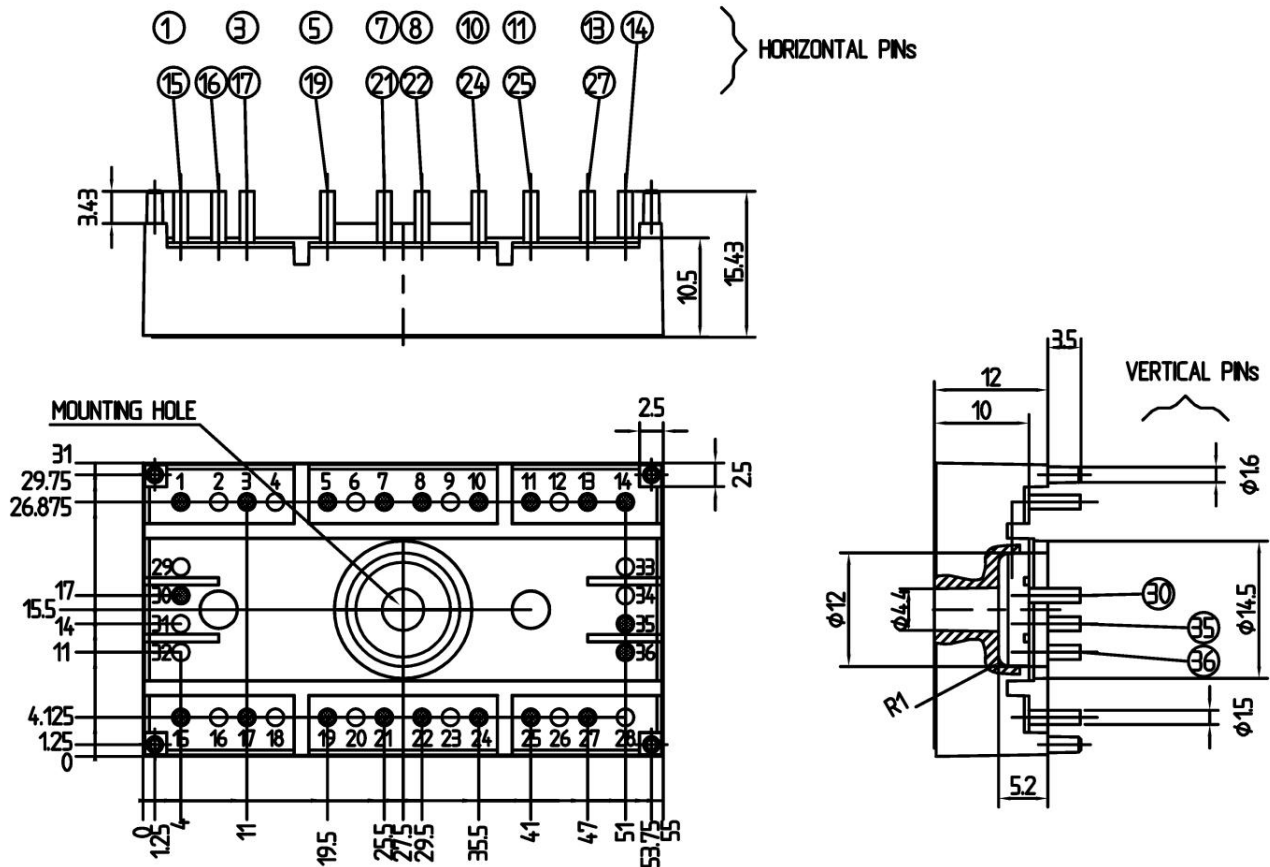

Fig. 20 Typical Capacitances vs. V_{CE}



SK 25 DGD 065 ET

Dimensions in mm



Case T60 (Suggested hole diameter, in the PCB, for solder pins and plastic mounting pins: 2mm)

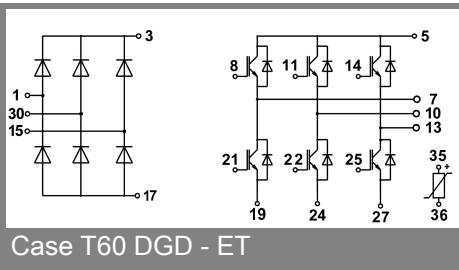

Case T60 DGD - ET

This is an electrostatic discharge sensitive device (ESDS), international standard IEC 60747-1, Chapter IX.

This technical information specifies semiconductor devices but promises no characteristics. No warranty or guarantee expressed or implied is made regarding delivery, performance or suitability.