



# ST21F384

## Smartcard MCU with 384 Kbytes of high density Flash memory

Data Brief

### Features

ST21F384 major applications include:

- Mobile communications (GSM, 3G and CDMA)
- Java applications

### Hardware features

- Enhanced 8/16-bit CPU core with 16 Mbytes linear addressable memory
- 7 Kbytes User RAM
- 384 Kbytes User Flash memory with OTP area:
  - 10-year data retention
  - 100,000 Erase/Write cycles
  - Page granularity of 128 Bytes
  - Block granularity: 1 Kbyte
  - 128 Bytes of OTP for User
  - Page Erase time 3 ms
  - Block Erase 1 Kbyte in 15 ms
  - Byte programming in 18  $\mu$ s
  - Flash Erase / Write Protection software programmable on 64 Kbyte Sectors
  - Field / Loader mode management
- Asynchronous Receiver Transmitter supporting ISO 7816-3 T=0 and T=1 protocols
- Two 8-bit timers with interrupt capability
- 1.8V, 3V and 5V supply voltage ranges
- External clock frequency from 1 up to 7.5 MHz
- High performance provided by:
  - CPU clock frequency up to 22 MHz
  - External clock multiplier (2x, 3x, and 4x)
- Current consumption complies with GSM and ETSI specifications
- Power-saving Standby state
- Contact assignment compatible ISO 7816-2
- ESD protection greater than 4 kV (HBM)

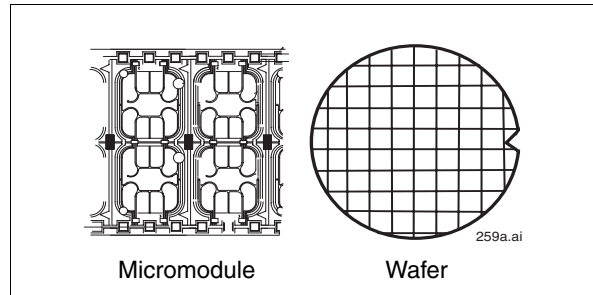

### Software features

- Flash Loader
- Flash drivers

### Security features

- Monitoring of environmental parameters
- Protection against faults
- ISO 3309 CRC calculation block
- Cryptographic performances<sup>(1)</sup>:
  - Triple DES (with keys loaded): 9.3  $\mu$ s
  - Single DES (with keys loaded): 3.1  $\mu$ s
- True Random Number Generator
- Unique serial number on each die
- Hardware DES accelerator

### Development environment

Software development and firmware generation are supported by a comprehensive set of development tools dedicated to software design and validation:

- C Compiler
- Simulator
- Emulator

1. Typical values at 22 MHz

# 1 Description

The ST21F384 product is a serial access microcontroller specially designed for cost-effective secure mobile applications.

It is based on an enhanced STMicroelectronics 8/16-bit CPU core offering **16 MBytes linear addressing space**.

It is manufactured using an advanced highly reliable ST Flash technology.

The device includes a DES accelerator.

A serial interface fully compatible with the ISO 7816-3 standard (T = 0 and T = 1) for Smartcard applications is available.

A CRC calculation block is also available and is directly accessible by the User.

The product architecture is optimized for low power consumption applications. A flexible clock generator module provides increased performance for specific current requirements.

ST drivers and ST Loader are located in the ST ROM area.

**Figure 1. ST21F384 Block diagram**

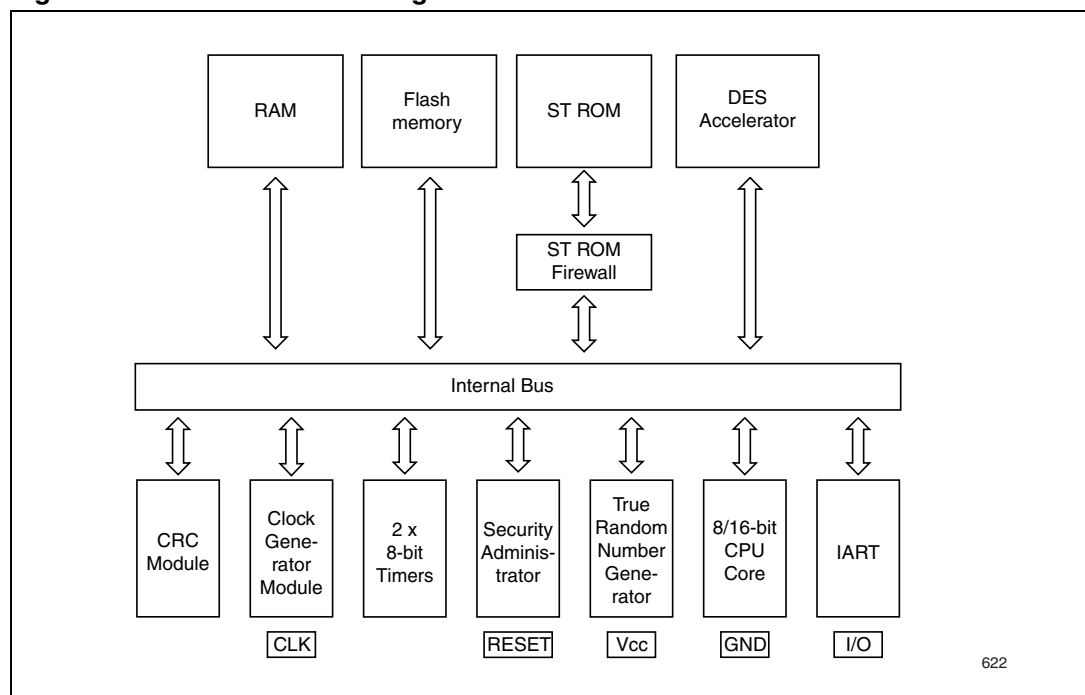

## 1.1 Development environment

Development tools for smartcard products include a complete range of hardware systems and software tools from STMicroelectronics and third-party tool suppliers. The range of tools includes solutions to help you to develop and debug your application and evaluate smartcard products and their peripherals.

An Integrated Development Environment (IDE), the STMicroelectronics Visual Debug (STVD), provides a set of tools for developing embedded applications. This interface manages the project configuration, code edition, code generation and program debugging.

A Smartcard ICS emulator (SCICS) and simulator are available for developing and validating your application code.

All the information needed to generate the application code and personalization will be collected in a delivery file (.DLV extension). This file is created using the Delivery menu of the STMicroelectronics configuration software tool, SCool.

## 2 Revision history

**Table 1. Document revision history**

Date	Revision	Changes
22-Oct-2007	1	Initial release

**Please Read Carefully:**

Information in this document is provided solely in connection with ST products. STMicroelectronics NV and its subsidiaries ("ST") reserve the right to make changes, corrections, modifications or improvements, to this document, and the products and services described herein at any time, without notice.

All ST products are sold pursuant to ST's terms and conditions of sale.

Purchasers are solely responsible for the choice, selection and use of the ST products and services described herein, and ST assumes no liability whatsoever relating to the choice, selection or use of the ST products and services described herein.

No license, express or implied, by estoppel or otherwise, to any intellectual property rights is granted under this document. If any part of this document refers to any third party products or services it shall not be deemed a license grant by ST for the use of such third party products or services, or any intellectual property contained therein or considered as a warranty covering the use in any manner whatsoever of such third party products or services or any intellectual property contained therein.

**UNLESS OTHERWISE SET FORTH IN ST'S TERMS AND CONDITIONS OF SALE ST DISCLAIMS ANY EXPRESS OR IMPLIED WARRANTY WITH RESPECT TO THE USE AND/OR SALE OF ST PRODUCTS INCLUDING WITHOUT LIMITATION IMPLIED WARRANTIES OF MERCHANTABILITY, FITNESS FOR A PARTICULAR PURPOSE (AND THEIR EQUIVALENTS UNDER THE LAWS OF ANY JURISDICTION), OR INFRINGEMENT OF ANY PATENT, COPYRIGHT OR OTHER INTELLECTUAL PROPERTY RIGHT.**

**UNLESS EXPRESSLY APPROVED IN WRITING BY AN AUTHORIZED ST REPRESENTATIVE, ST PRODUCTS ARE NOT RECOMMENDED, AUTHORIZED OR WARRANTED FOR USE IN MILITARY, AIR CRAFT, SPACE, LIFE SAVING, OR LIFE SUSTAINING APPLICATIONS, NOR IN PRODUCTS OR SYSTEMS WHERE FAILURE OR MALFUNCTION MAY RESULT IN PERSONAL INJURY, DEATH, OR SEVERE PROPERTY OR ENVIRONMENTAL DAMAGE. ST PRODUCTS WHICH ARE NOT SPECIFIED AS "AUTOMOTIVE GRADE" MAY ONLY BE USED IN AUTOMOTIVE APPLICATIONS AT USER'S OWN RISK.**

Resale of ST products with provisions different from the statements and/or technical features set forth in this document shall immediately void any warranty granted by ST for the ST product or service described herein and shall not create or extend in any manner whatsoever, any liability of ST.

ST and the ST logo are trademarks or registered trademarks of ST in various countries.

Information in this document supersedes and replaces all information previously supplied.

The ST logo is a registered trademark of STMicroelectronics. All other names are the property of their respective owners.

© 2007 STMicroelectronics - All rights reserved  
BULL CP8 Patents

STMicroelectronics group of companies

Australia - Belgium - Brazil - Canada - China - Czech Republic - Finland - France - Germany - Hong Kong - India - Israel - Italy - Japan -  
Malaysia - Malta - Morocco - Singapore - Spain - Sweden - Switzerland - United Kingdom - United States of America

[www.st.com](http://www.st.com)