

Nine Channel PMU for Mobile Phones

FEATURES

- Multiple Patents Pending
- Li+ Battery Charger with Integrated MOSFET
 - ON/OFF Control
- Charger Current Monitor Output
- Six Low Noise LDOs
 - 3.00V at 250mA
 - 1.80V at 150mA
 - 3.00V at 80mA
 - 3.00V at 80mA
 - 3.00V at 80mA
 - 3.00V at 150mA
 - Programmable LDO Output Voltages
- Two N-channel Open Drain Switches
- I²C™ Compatible Serial Interface
 - Configurable Operating Modes
- AC OK (nACOK) and RESET (nRST) Outputs
- 5x5mm, QFN (QFN55-32) Package
 - RoHS Compliant

APPLICATIONS

- GSM or CDMA Mobile Phones

GENERAL DESCRIPTION

The patent-pending ACT5810 is a complete, integrated power management solution that is ideal for CDMA and GSM mobile phones. This device integrates a linear Li+ battery charger with an internal power MOSFET, six low dropout linear regulators (LDOs), a reset output, and two N-Channel open drain switches. An I²C Serial Interface is utilized to provide programmable LDO and battery charger functionality.

The ACT5810 features six low-noise LDOs and are divided into two sets of three: one set optimized for minimum quiescent supply current, and the other optimized for high PSRR, achieving more than 60dB PSRR at frequencies up to 10kHz. All LDO output voltages may be programmed as well as enabled and disabled via the I²C interface.

The charger is a complete, thermally-regulated, stand-alone single-cell linear mode charger for Li+ batteries. It incorporates an internal power MOSFET for constant-current/constant-voltage control. The battery regulation voltage has 0.5% accuracy, and features programmable charger currents in the 90mA to 1A range as well as a variety of other functions including a complete charge-management state machine and charge safety timers.

SYSTEM BLOCK DIAGRAM

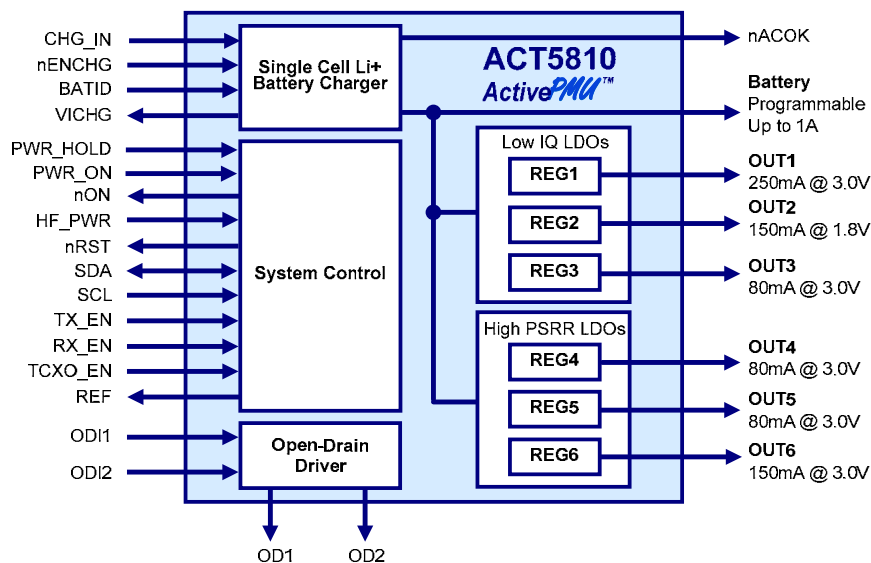

PRODUCT OPTIONS

Block	Function	Output Voltage ^①	Capability ^②
CHGR	Battery Charger	4.20V (4.10V to 4.24V available)	Programmable Up to 1A
REG1	LDO	3.0V (1.4V to 3.7V)	250mA
REG2	LDO	1.8V (1.4V to 3.7V)	150mA
REG3	LDO	3.0V (1.4V to 3.7V)	80mA
REG4	LDO	3.0V (1.4V to 3.7V)	80mA
REG5	LDO	3.0V (1.4V to 3.7V)	80mA
REG6	LDO	3.0V (1.4V to 3.7V)	150mA
OD1	Open Drain	N/A	100mA
OD2	Open Drain	N/A	100mA

①: Output voltage options detailed in this table represent standard voltage options, and are available for samples or production orders. Contact Active-Semi for more information regarding semi-custom output voltage combinations.

②: Contact factory for additional available products or custom requirements.

FUNCTIONAL BLOCK DIAGRAM

