

SMDQ-100H



Single Phase Bridge Rectifier Module



Type	V_{RSM}	V_{RRM}
SMDQ-100H-08	1000	800
SMDQ-100H-10	1200	1000
SMDQ-100H-12	1400	1200
SMDQ-100H-14	1600	1400
SMDQ-100H-16	1800	1600
SMDQ-100H-18	2000	1800

Type	I_{DAV}	T_c	I_{FSM}	i^2t	V_{TM}	I_{FM}	V_{TO}	r_T	T_{VJ}	V_{isol}	R_{thJC}
	A	$^{\circ}C$	KA	KA^2s	V	A	V	$m\Omega$	$^{\circ}C$	V	K/W
SMDQ-100H	100	100	1.5	11.2	1.53	150	0.8	4	150	2500	0.24

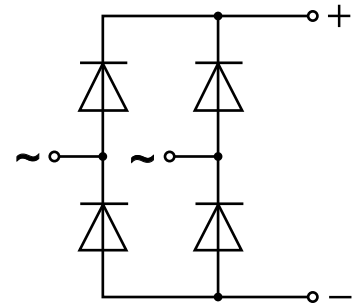
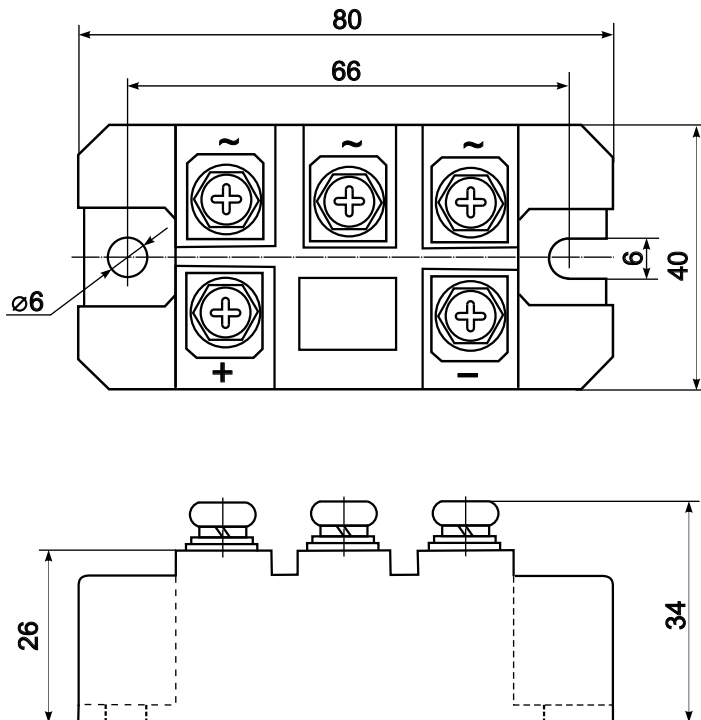

Features:

- Industrial standard package
- Heat transfer through aluminium nitride ceramic isolated metal baseplate
- Precise internal pressure contacts for high reliability
- 2500V RMS isolation voltage

Typical Applications:

- DC power supply for instrument and equipment
- Power converters
- Electronic welders
- Lighting control