

RoHS COMPLIANT

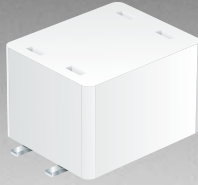

BOURNS®

Features

- Two resistance-matched PTCs in a ceramic housing
- Aids compliance with:
 - ITU-T K.20/21/45
 - Telcordia GR-1089-CORE
 - UL 60950, 3rd Ed.
- Narrow resistance tolerance
- RoHS compliant*

Applications

Used as a secondary overcurrent protection device in:

- Customer Premise Equipment (CPE)
- Central Office (CO)
- Access equipment

CMF-SD Series - Telecom CPTC Resettable Fuses

Electrical Characteristics

Model	Induction Voltage Withstand	Rated Voltage	Rated Resistance (RN)		Resistance Matching In Housing	Hold Current	Trip Current	I _{max} @ 230 VAC	Time to Trip @ I _{max} /230 VAC
	VAC	Volts	Ohms	Tolerance	Ohms	Amps @ 25 °C	Amps @ 25 °C	Amps	Seconds
CMF-SD25	600	230	25	±20 %	± 0.5	0.130	0.260	2.8	< 0.3
CMF-SD25-10	600	230	25	±10 %	± 0.5	0.130	0.260	2.8	< 0.3
CMF-SD35	600	230	35	±20 %	± 0.5	0.100	0.200	3	< 0.2
CMF-SD35-10	600	230	35	±10 %	± 0.5	0.100	0.200	3	< 0.2
CMF-SD35A	600	230	35	±20 %	± 0.5	0.100	0.200	2.5	< 0.2
CMF-SD35A-10	600	230	35	±10 %	± 0.5	0.100	0.200	2.5	< 0.2
CMF-SD50	600	230	50	±20 %	± 0.5	0.090	0.190	3	< 0.1
CMF-SD50-10	600	230	50	±10 %	± 0.5	0.090	0.190	3	< 0.1
CMF-SD50A	600	230	50	±20 %	± 0.5	0.090	0.190	3	< 0.1
CMF-SD50A-10	600	230	50	±10 %	± 0.5	0.090	0.190	3	< 0.1

Product Dimensions

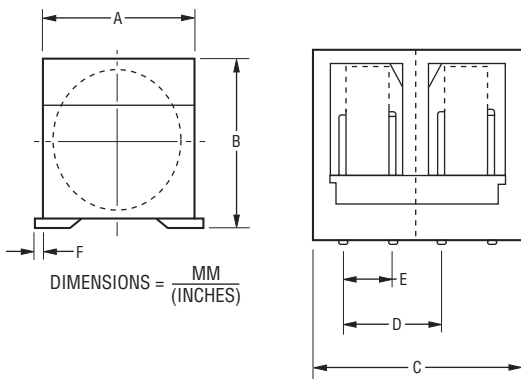

Packaging options:
 TAPE & REEL: CMF-SD25, CMF-SD35 & CMF-SD50 = 400 pcs. per reel;
 CMF-SD35A & CMF-SD50A = 500 pcs. per reel

Dim.	CMF-SD25 CMF-SD35 CMF-SD50	CMFSD35A CMF-SD50A
A	$\frac{9.00}{(.354)}$ MAX.	$\frac{7.15}{(.281)}$ MAX.
B	$\frac{10.80}{(.425)}$ MAX.	$\frac{8.50}{(.335)}$ MAX.
C	$\frac{10.20}{(.402)}$ MAX.	$\frac{8.10}{(.319)}$ MAX.
D	$\frac{4.88 - 5.28}{(.192 - .208)}$	$\frac{3.25 - 3.65}{(.128 - .144)}$
E	$\frac{2.41 - 2.61}{(.095 - .103)}$	$\frac{2.41 - 2.61}{(.095 - .103)}$
F	$\frac{0.5}{(.020)}$ MAX.	$\frac{0.5}{(.020)}$ MAX.

Recommended Pad Layout

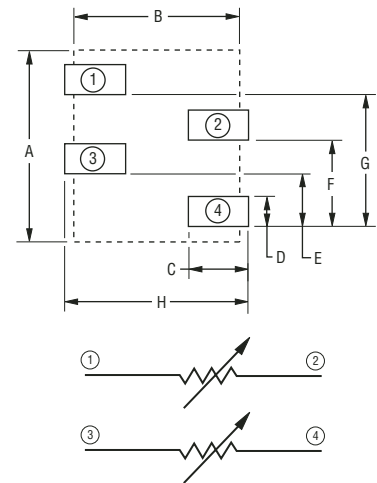

Typical Part Marking

Represents total content. Layout may vary.

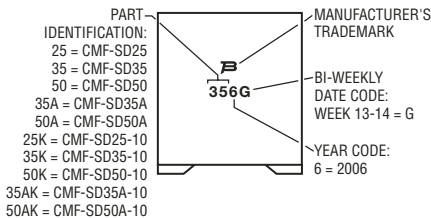

How to Order

CMF - SD 35 A - 10 - 2

Product Designator
 Style SD = Surface Mount Dual Pkg.
 Rated Resistance (RN) 25, 35, 50 (25, 35, 50 Ohms)
 Reduced Footprint and Height Option
 Resistance Tolerance Option Blank = Standard (20 %) -10 = 10 %
 Packaging Options - 2 = Tape & Reel

Dim.	CMF-SD25/ CMF-SD35/ CMF-SD50	CMF-SD35A/ CMF-SD50A
A	$\frac{10.0}{(.394)}$	$\frac{8.00}{(.315)}$
B	$\frac{8.80}{(.346)}$	$\frac{7.05}{(.278)}$
C	$\frac{3.20}{(.126)}$	$\frac{2.75}{(.108)}$
D	$\frac{2.00}{(.079)}$	$\frac{2.00}{(.079)}$
E	$\frac{2.60}{(.102)}$	$\frac{2.51}{(.099)}$
F	$\frac{5.00}{(.197)}$	$\frac{3.45}{(.136)}$
G	$\frac{7.60}{(.299)}$	$\frac{5.95}{(.234)}$
H	$\frac{10.0}{(.394)}$	$\frac{8.15}{(.321)}$

*RoHS Directive 2002/95/EC Jan 27 2003 including Annex.
 Specifications are subject to change without notice.
 Customers should verify actual device performance in their specific applications.

Solder Reflow Recommendations

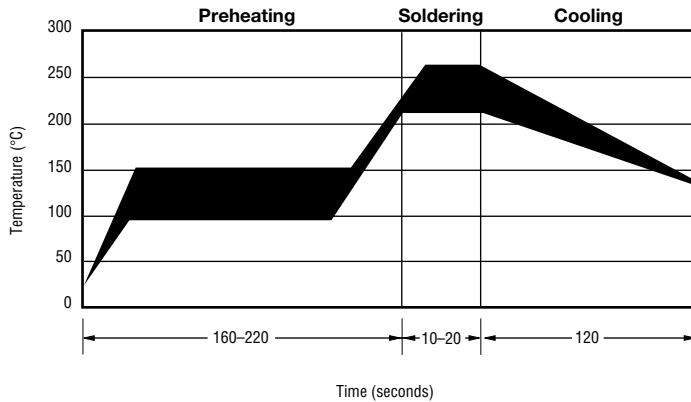

Solder reflow

- Recommended reflow methods: IR, vapor phase oven, hot air oven.
- Devices are not designed to be wave soldered to the bottom side of the board.
- Gluing the devices is not recommended.
- Recommended maximum paste thickness is 0.25 mm (.010 inch).
- Devices can be cleaned using standard industry methods and solvents.

Note:

- If reflow temperatures exceed the recommended profile, devices may not meet the performance requirements.

Rework

- A device should not be reworked.



Asia-Pacific:

Tel: +886-2 2562-4117 • Fax: +886-2 2562-4116

Europe:

Tel: +41-41 768 5555 • Fax: +41-41 768 5510

The Americas:

Tel: +1-951 781-5500 • Fax: +1-951 781-5700

www.bourns.com

CMF-SD Series Tape and Reel Specifications

BOURNS®

Tape Dimensions per EIA 481-2	CMF-SD25-2 CMF-SD35-2 CMF-SD50-2	CMF-SD35A-2 CMF-SD50A-2
W	$\frac{24.0 \pm 0.30/-0.10}{(0.945 \pm 0.012/-0.004)}$	$\frac{16.0 \pm 0.10}{(0.630 \pm 0.004)}$
P ₀	$\frac{4.00 \pm 0.10}{(0.157 \pm 0.004)}$	$\frac{4.00 \pm 0.10}{(0.157 \pm 0.004)}$
P	$\frac{16.0 \pm 0.10}{(0.630 \pm 0.004)}$	$\frac{12.0 \pm 0.10}{(0.472 \pm 0.004)}$
P ₂	$\frac{2.00 \pm 0.10}{(0.079 \pm 0.004)}$	$\frac{2.00 \pm 0.10}{(0.079 \pm 0.004)}$
A ₀	$\frac{10.2 \pm 0.10}{(0.402 \pm 0.004)}$	$\frac{8.35 \pm 0.10}{(0.329 \pm 0.004)}$
B ₀	$\frac{9.0 \pm 0.10}{(0.354 \pm 0.004)}$	$\frac{8.30 \pm 0.10}{(0.327 \pm 0.004)}$
D	$\frac{1.5 \pm 0.10/-0.0}{(0.059 \pm 0.004/-0.0)}$	$\frac{1.5 \pm 0.10/-0.0}{(0.059 \pm 0.004/-0.0)}$
F	$\frac{11.5 \pm 0.10}{(0.453 \pm 0.004)}$	$\frac{7.5 \pm 0.10}{(0.295 \pm 0.004)}$
E	$\frac{1.75 \pm 0.10}{(0.069 \pm 0.004)}$	$\frac{1.75 \pm 0.10}{(0.069 \pm 0.004)}$
T max.	$\frac{0.50}{(0.020)}$	$\frac{0.50}{(0.020)}$
K ₀	$\frac{11.0 \pm 0.10}{(0.433 \pm 0.004)}$	$\frac{8.80 \pm 0.10}{(0.346 \pm 0.004)}$

CMF-SD25-2
CMF-SD35-2
CMF-SD50-2

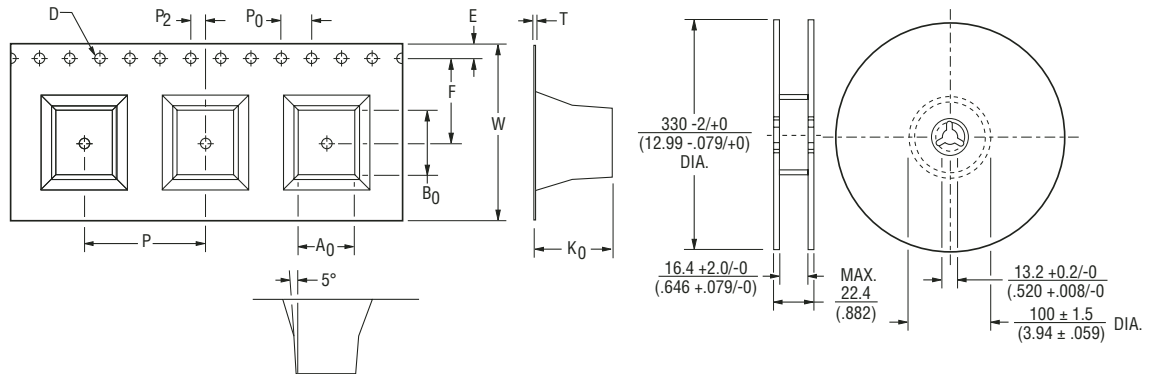

CMF-SD35A-2
CMF-SD50A-2

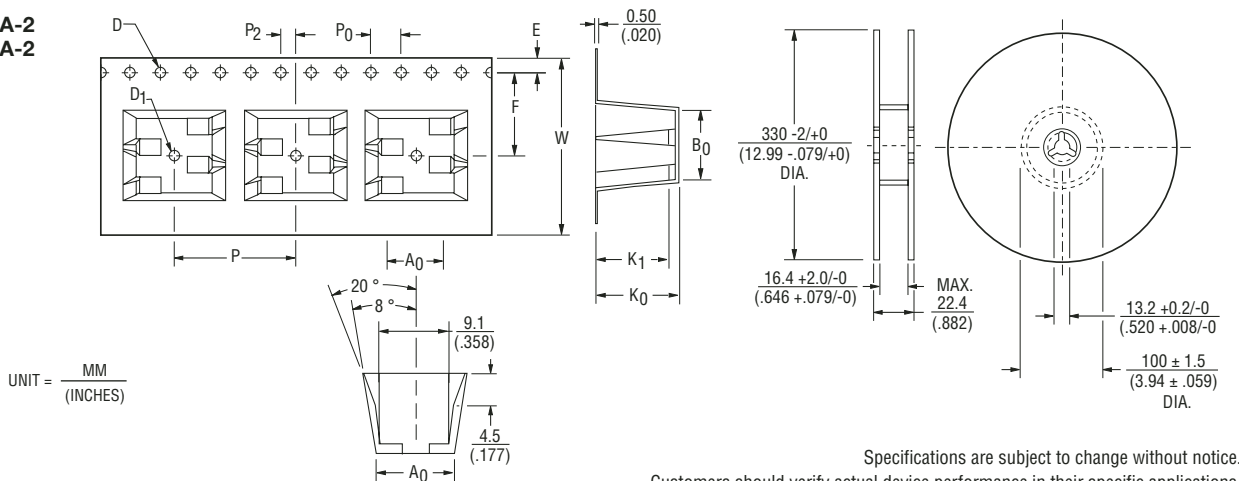

UNIT = $\frac{\text{MM}}{\text{(INCHES)}}$

Specifications are subject to change without notice.
Customers should verify actual device performance in their specific applications.