

# Accutek Microcircuit Corporation

## AK63264W-72 65,536 x 32 Bit CMOS/BiCMOS 72 Pin Format Static Random Access Memory

### DESCRIPTION

The Accutek AK63264W-72 SRAM Module consists of fast high performance SRAMs mounted on a low profile, 72 pin SIM Board. The module utilizes eight 28 pin 64K x 4 SRAMs in SOJ packages and four decoupling capacitors mounted on each side of a printed circuit board.

The SRAMs used have common I/O functions and single output enable functions. Also, four separate chip select ( $\overline{CE}$ ) connections are used to independently enable the four bytes. The modules can be supplied in a variety of access time values from 12 nSEC to 45 nSEC in CMOS or BiCMOS technology.

The Accutek module is designed to have a maximum seated height of 0.600 inch to provide for the lowest height off the board. By off-set-mounting the back surface SRAMs the module can be mounted in either angled or straight-up SIM sockets. The module conforms to JEDEC standard sizes and pin-out configurations. Using two pins for module memory density identification, PD<sub>0</sub> and PD<sub>1</sub>, minimizes interchangeability and design considerations when changing from one module size to another in customer applications.

### FEATURES

- 65,536 x 32 bit organization
- JEDEC Standardized 72 pin SIM or ZIP pinout
- Common I/O, single  $\overline{OE}$  functions with four separate chip selects ( $\overline{CE}$ )
- Low height, 0.600 inch maximum
- Upward compatible with 256K x 32 (AK632256) 512K x 32 (AK632512) and 1 Meg x 32 (AK6321024)
- TTL-compatible inputs and outputs

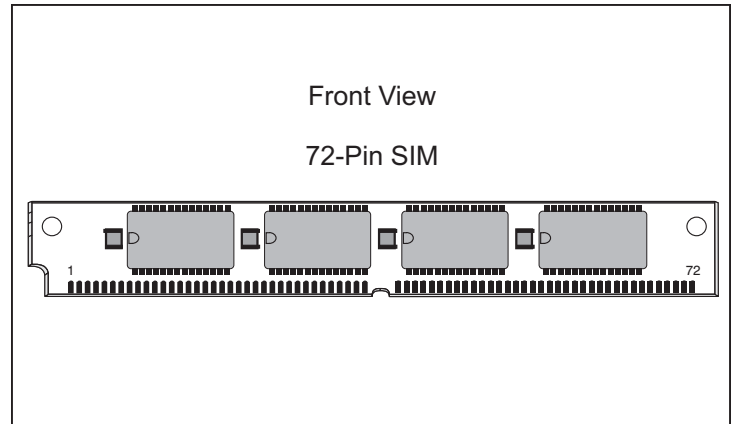

- Downward compatible with 128K x 32 (AK632128) and 32K x 32 (AK63232)
- Presence Detect PD<sub>0</sub> and PD<sub>1</sub> for identifying module density
- Fast access times range from 12 nSEC BiCMOS to 45 nSEC CMOS
- Single 5 volt power supply - AK63264W-72
- Single 3.3 volt power supply - AK63264W-72/3.3
- Operating temperature range in free air, 0°C to 70°C
- Available with solder or gold leads

### ELECTRICAL SPECIFICATIONS

Timing diagrams and basic electrical characteristics are those of the standard 64K x 4 SRAMs used to construct these modules. Accutek's module design allows the flexibility of selecting industry-compatible 64K x 4 SRAMs from several semiconductor manufacturers.

### PIN NOMENCLATURE

A <sub>0</sub> - A <sub>15</sub>	Address Inputs
$\overline{CE}_1$ - $\overline{CE}_4$	Chip Enable
DQ <sub>1</sub> - DQ <sub>32</sub>	Data In/Data Out
$\overline{OE}$	Output Enable
PD <sub>0</sub> - PD <sub>3</sub>	Presence Detect
V <sub>cc</sub>	Power Supply
V <sub>ss</sub>	Ground
$\overline{WE}$	Write Enable
NC	No Connect

### PIN ASSIGNMENT

PIN #	SYMBOL	PIN #	SYMBOL	PIN #	SYMBOL	PIN #	SYMBOL
1	NC	19	A1	37	$\overline{CE}_4$	55	A5
2	NC	20	A8	38	$\overline{CE}_3$	56	A12
3	NC	21	A2	39	NC	57	V <sub>cc</sub>
4	NC	22	A9	40	NC	58	A13
5	V <sub>ss</sub>	23	DQ13	41	$\overline{OE}$	59	A6
6	PD0	24	DQ5	42	V <sub>ss</sub>	60	DQ21
7	PD1	25	DQ14	43	DQ25	61	DQ29
8	DQ1	26	DQ6	44	DQ17	62	DQ22
9	DQ9	27	DQ15	45	DQ26	63	DQ38
10	DQ2	28	DQ7	46	DQ18	64	DQ23
11	DQ10	29	DQ16	47	DQ27	65	DQ31
12	DQ3	30	DQ8	48	DQ19	66	DQ24
13	DQ11	31	V <sub>ss</sub>	49	DQ28	67	DQ32
14	DQ4	32	$\overline{WE}$	50	DQ20	68	V <sub>ss</sub>
15	DQ12	33	A15	51	A3	69	NC
16	V <sub>cc</sub>	34	A14	52	A10	70	NC
17	A0	35	$\overline{CE}_2$	53	A4	71	NC
18	A7	36	$\overline{CE}_1$	54	A11	72	NC

PD<sub>0</sub> = Open  
PD<sub>1</sub> = V<sub>ss</sub>

### MODULE OPTIONS

Leadless SIM: AK63264W-72

### FUNCTIONAL DIAGRAM

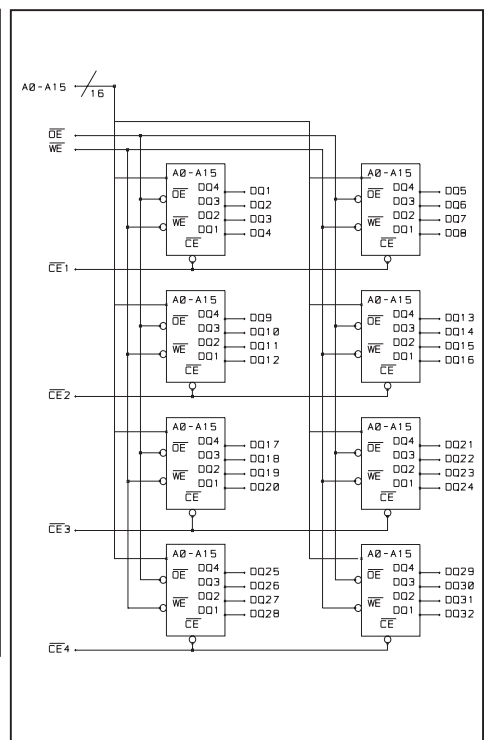

## ORDERING INFORMATION

### PART NUMBER CODING INTERPRETATION

Position	1	2	3	4	5	6	7	8
<b>1 Product</b>								
	<b>AK = Accuthek Memory</b>							
<b>2 Type</b>								
	4 = Dynamic RAM							
	5 = CMOS Dynamic RAM							
	6 = Static RAM							
<b>3 Organization/Word Width</b>								
	1 = by 1 16 = by 16							
	4 = by 4 32 = by 32							
	8 = by 8 36 = by 36							
	9 = by 9							
<b>4 Size/Bits Depth</b>								
	64 = 64K		4096 = 4 MEG					
	256 = 256K		8192 = 8 MEG					
	1024 = 1 MEG		16384 = 16 MEG					
<b>5 Package Type</b>								
	<b>G = Single In-Line Package (SIP)</b>							
	<b>S = Single In-Line Module (SIM)</b>							
	<b>D = Dual In-Line Package (DIP)</b>							
	<b>W = .050 inch Pitch Edge Connect</b>							
	<b>Z = Zig-Zag In-Line Package (ZIP)</b>							
<b>6 Special Designation</b>								
	P = Page Mode							
	N = Nibble Mode							
	K = Static Column Mode							
	W = Write Per Bit Mode							
	V = Video Ram							
<b>7 Separator</b>								
	- = Commercial 0°C to +70°C							
	M = Military Equivalent Screened (-55°C to +125°C)							
	I = Industrial Temperature Tested (-45°C to +85°C)							
	X = Burned In							
<b>8 Speed (first two significant digits)</b>								
	DRAMS				SRAMS			
	50 = 50 nS		12 = 12 nS					
	60 = 60 nS		15 = 15 nS					
	70 = 70 nS		20 = 20 nS					
	80 = 80 nS		25 = 25 nS					

The numbers and coding on this page do not include all variations available but are shown as examples of the most widely used variations. Contact Accuthek if other information is required.

### EXAMPLES:

**AK63264W72-12**

64K x 32, 12 nSEC SRAM Module, 72 Pin SIM Configuration



**ACCUTEK MICROCIRCUIT CORPORATION**  
 BUSINESS CENTER at NEWBURYPORT  
 2 NEW PASTURE ROAD, SUITE 1  
 NEWBURYPORT, MA 01950-4054  
 PHONE: 978-465-6200 FAX: 978-462-3396  
 Email: sales@accutekmicro.com  
 Internet: www.accutekmicro.com

## MECHANICAL DIMENSIONS

Inches

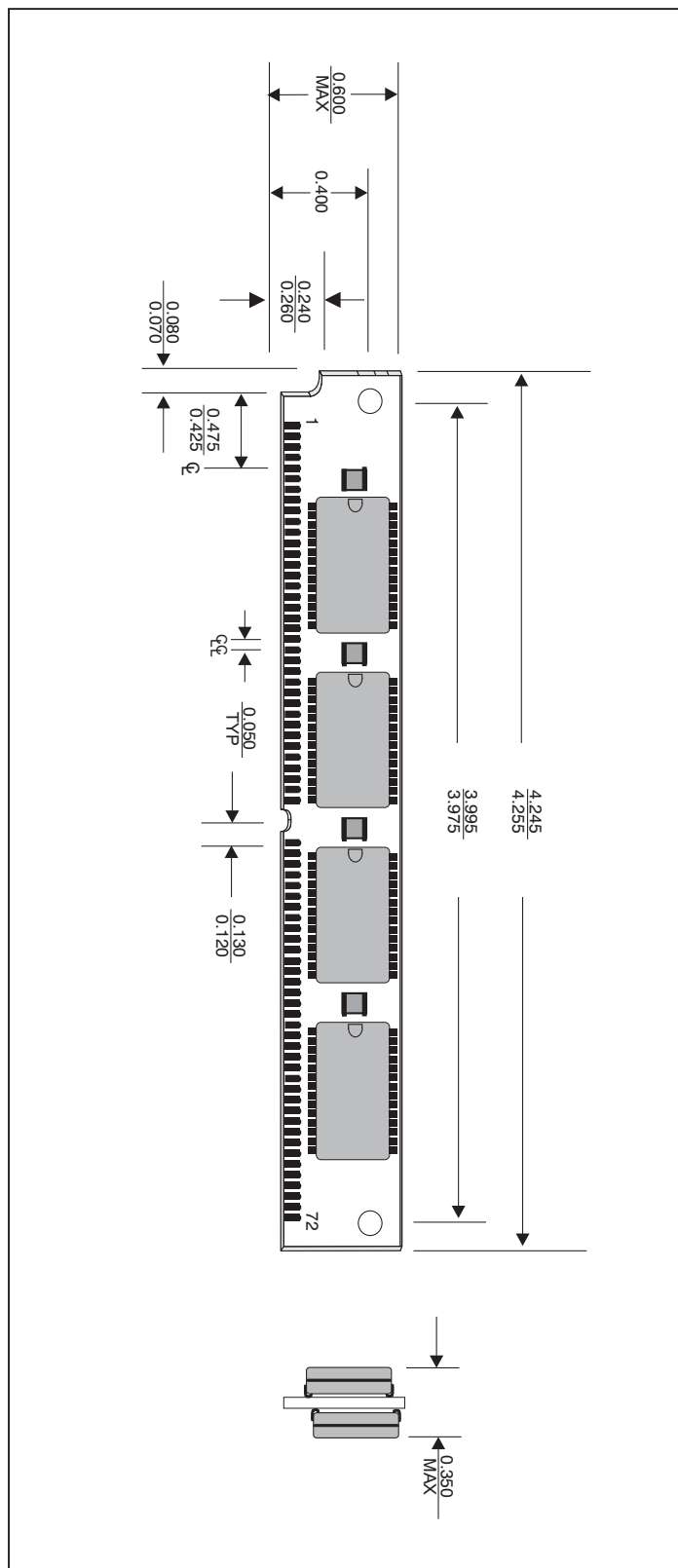

Accuthek reserves the right to make changes in specifications at any time and without notice. Accuthek does not assume any responsibility for the use of any circuitry described; no circuit patent licenses are implied. Preliminary data sheets contain minimum and maximum limits based upon design objectives, which are subject to change upon full characterization over the specific operating conditions.