



Using KEELOQ[®] to Generate Hopping Passwords

Author: Lucio Di Jasio
Arizona Microchip Technology, Italy

INTRODUCTION

The purpose of this application note is to demonstrate how KEELOQ[®] code hopping technology can be conveniently employed to implement an automatic code hopping password generator/keypad. Using a PIC12C508, the hopping code produced by an HCS300 is converted to a string of 16 hex digits. This string is then transferred to the PC via the keyboard line, thereby emulating the actual pressure of a sequence of keys on a standard PC/AT[®] keyboard. Since this conversion process is transparent to any application, it appears as if the user is simply typing on a PC/AT-type keyboard.

An ideal situation for implementing this application would be in creating a "super password" for general, access-control secure logins when transmitting information onto the internet (i.e., through a browser) or a Java applet.

THE "HOPPING" ADVANTAGE

Password-based access control systems are very popular today, but the level of security they provide are often overestimated. Being basically a unidirectional transmission, a password-based system has two very important shortcomings which can lead to unauthorized access: the code is fixed, and the number of possible combinations is relatively low.

The growing speed of communication lines and the computing power of available systems increases the chance of a brute force attack or "code scanning." The use of unsecure means of transmission, where code "grabbing" is possible (i.e., a typical modem connection over phone lines), can make the use of a fixed code highly undesirable. Note that these are the same situation that led to the introduction of the "code hopping" concept in the remote control market.

The basic idea is to have the access code change each time it is used through a sequence where the new codes cannot be predicted even knowing a very large number of previously used ones. Producing such a sequence requires the use of a solid encryption engine. Microchip Technology is currently offering a broad range of encoders based on the proprietary KEELOQ code hopping technology. These encoders make producing a code hopping remote control easy, but as we will see, can also be conveniently used to add the hopping advantage to old password based access control systems in a transparent way.

FIGURE 1: HCS300 AND PIC12C508 PINOUT DIAGRAMS

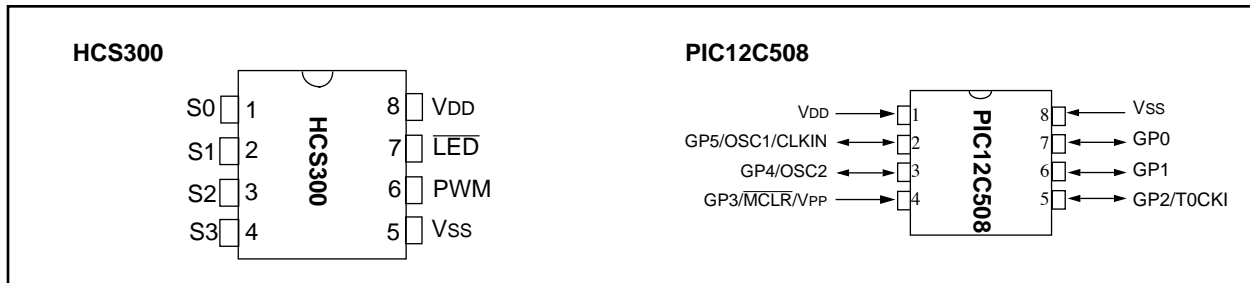

KEELOQ is a registered trademark of Microchip Technology, Inc.
Microchip's Secure Data Products are covered by some or all of the following patents:
Code hopping encoder patents issued in Europe, U.S.A., and R.S.A. — U.S.A.: 5,517,187; Europe: 0459781; R.S.A.: ZA93/4726
Secure learning patents issued in the U.S.A. and R.S.A. — U.S.A.: 5,686,904; R.S.A.: 95/5429
IBM PC-AT, IBM and AT are registered trademarks of International Business Machines Corporation

INTRODUCTION TO KEELOQ ENCODERS

All KEELOQ encoders use the KEELOQ code hopping technology to make each transmission by an encoder unique. The encoder transmissions have two parts. The first part changes each time the encoder is activated and is called the code hopping part and is encrypted. The second part is the unencrypted part of the transmission, principally containing the encoder serial number identifying it to a decoder.

The code hopping contains function information, a discrimination value, and a synchronization counter. This information is encrypted by an encryption algorithm before being transmitted. A 64-bit encryption key is used by the encryption algorithm. If one bit in the data that is encrypted changes, the result is that an average of half the bits in the output will change. As a result, the code hopping changes dramatically for each transmission and can not be predicted.

The synchronization information is used at the decoder to determine whether a transmission is valid or is a repetition of a previous transmission. Previous codes are rejected to safeguard against code grabbers.

The HSC300 and HCS301 encoders transmit two overflow bits which may be used to extend the range of the synchronization counter from 65,536 to 196,608 button operations. The HCS300 and HCS301 encoders include provision for four bits of function information and two status bits in the fixed code portion of its transmission. The two status bits indicate whether a repeated transmission is being sent, and whether the battery voltage is low.

The Microchip HCSXXX encoders all have the ability to transmit a fixed seed. The seed value is programmed into the encoder when the encoder is first initialized along with the counters, key, serial number, and other information. The seed length differs from encoder to encoder, with the HCS300 and HCS301 having a 32-bit seed.

FIGURE 2: KEELOQ ENCODER CODE WORD TRANSMISSION FORMAT

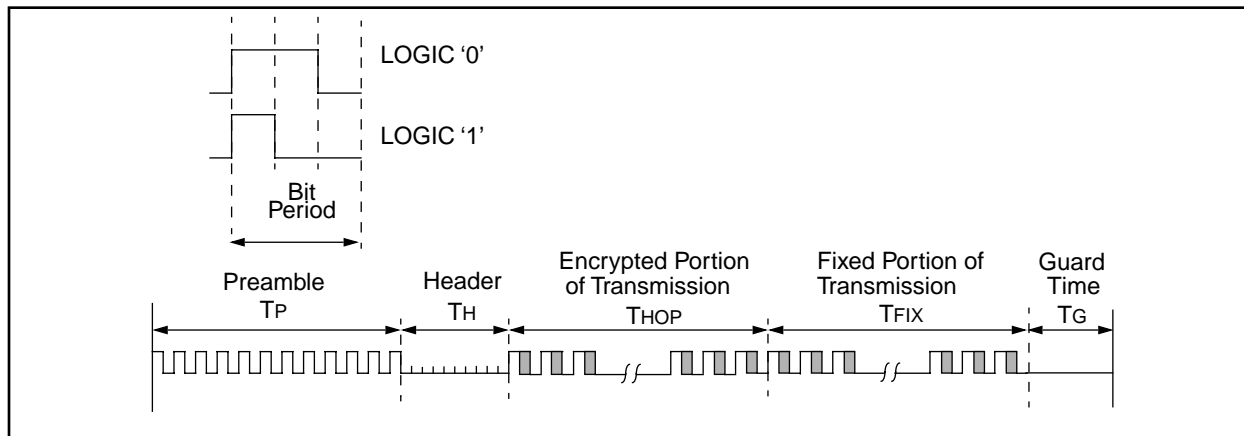

FIGURE 3: KEELOQ ENCODER CODE WORD ORGANIZATION

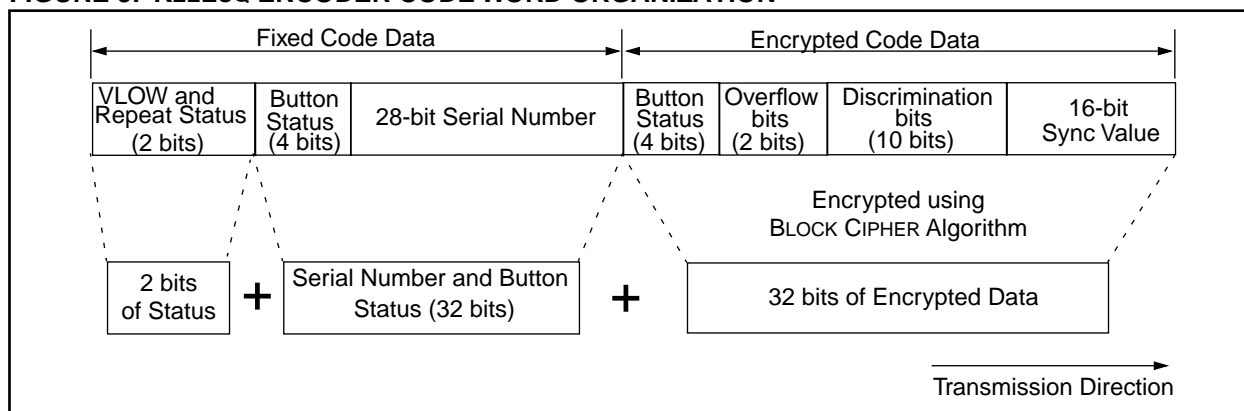
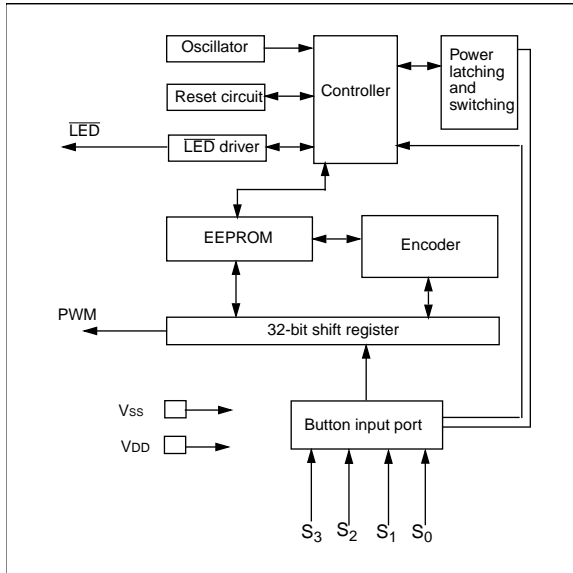

FIGURE 4: HCS300 BLOCK DIAGRAM



The IBM PC-AT® Keyboard Protocol

IBM® was the first to introduce the synchronous serial protocol most of today's PC-ATs use to communicate with a keyboard. This now-standard, 5-pole shielding connector (Figure 5) carries the clock line, data line, ground, and +5V power supply in order to transmit data bidirectionally from the keyboard to the PC.

Typically, data travelling from the keyboard to the PC is accomplished by either key pressure or release information. However, some configuration data (i.e., repeat, delay, and rate) can flow in the opposite direction – for example, during a system boot. The keyboard drives the clock line by using open collector drivers. To disable the keyboard, the PC can keep the clock line low. If the data line is held low by the PC while the clock line is high, the computer transmits a request to send, and the keyboard goes into receive mode. The keyboard is only allowed to send data when both the clock line and data line are high.

FIGURE 5: STANDARD 5-POLE CONNECTOR

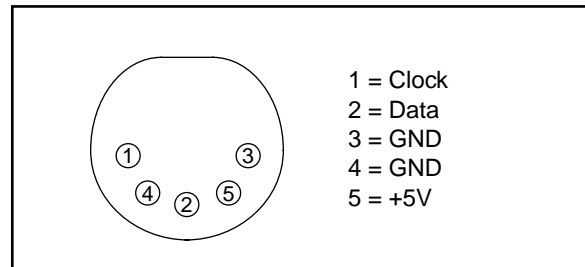
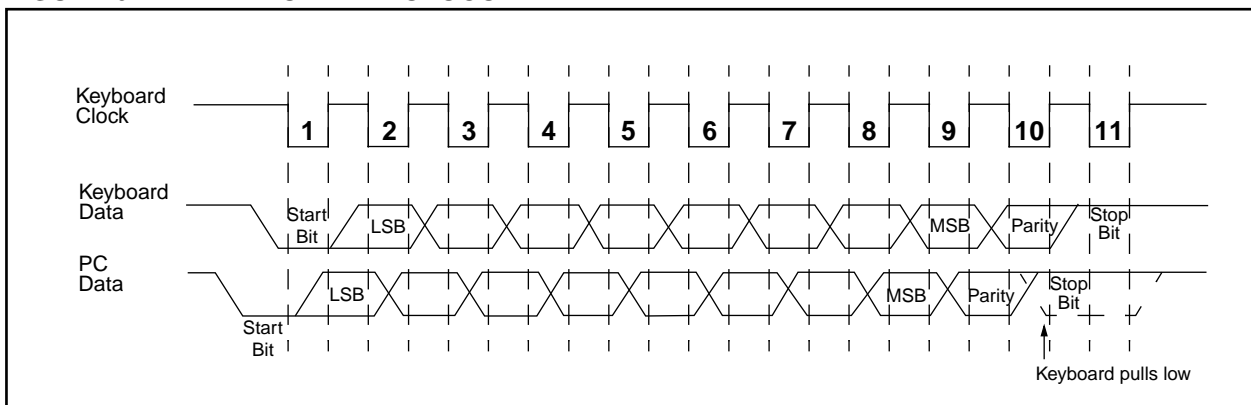

FIGURE 6: AT® KEYBOARD PROTOCOL



Keyboard Transmission

The keyboard pulls the data line low (start bit) and starts the clock. The eight data bits (least significant bit first) are shifted out, followed by the parity (odd), and stop bit (high). Data is valid after the falling edge of the clock and changes after the rising edge of the clock. If no data is transmitted, both the clock line and data line are high. If the computer pulls the clock line low for at least 60 μ s before the tenth bit is transmitted, the keyboard stops the transmission and stores the aborted data in a buffer for retransmission at a later time.

Keyboard Receiving

The computer pulls the data line low (start bit), after which the keyboard starts to shift out 11 clock pulses within 15 ms. Transmission has to be completed within 2 ms. Data from the computer changes after the falling edge of the clock line, and is valid before the rising edge of the clock. After the start bit, eight data bits (least significant bit first), followed by the parity bit (odd), and the stop bit (high) are shifted out by the computer with the clock signal provided by the keyboard. The keyboard pulls the stop bit low in order to acknowledge the receipt of the data. If a transmission error occurs (parity error or similar) the keyboard issues a "RESEND" command to the PC.

Key Pressure Release Encoding

Key pressure is communicated to the PC by sending a scan code. Table 1 lists the scan codes corresponding to keys '0'...'F'. Release is communicated by sending the break code (0F0), followed by the previous scan code.

TABLE 1: SCAN CODES

Codes	Key
45	'0'
16	'1'
1E	'2'
26	'3'
25	'4'
2E	'5'
36	'6'
3D	'7'
3E	'8'
46	'9'
1C	'A'
32	'B'
21	'C'
23	'D'
24	'E'
2B	'F'

Proposing a Demo Keypad/Dongle Implementation

The password generator fits between the keyboard and the PC. A 5-pin plug connects to the PC, supplying power to our device, and the keyboard plugs into the 5-pin socket (Figure 7). The clock and data lines are passed between the PC and keyboard, allowing normal keyboard operations. When S1 is activated, the PIC12C508 receives the new message (16 hex digits) produced by the KEELOQ HCS300 Encoder. The PIC12C508 will then emulate the keyboard, sending the appropriate sequence of key press and key release messages to the PC. To prevent the keyboard from interpreting this transmission as a 'request to send' from the PC, it is necessary to isolate the keyboard from the clock line and data line during the transmission.

The KEELOQ HCS300 Encoder can be part of the dongle or can be removable, like a key, in order to allow different encoders with different encryption keys or serial numbers to be easily exchanged.

Power consumption has to be the lowest possible in order not to excessively load the line. Size and component count should also be kept to the possible minimum in order to allow for a very small package. Ideally, the whole circuit should fit into a small gap between the two connectors.

In the implementation we are proposing, an HCS300 KEELOQ code hopping encoder is used together with a PIC12C508 microcontroller. For simplicity, a standard CMOS quadruple switch (4066) is used to alternatively connect the dongle or the keyboard to the PC line. The HCS300 and the PIC12C508 (both available in 8-pin DIP or SOIC packages), draw extremely low currents as well as internally produce the clock required to operate the dongle. Beside a couple of pull-up resistors required for the clock line and data line, no other components are required to obtain a fully functional hopping password dongle (Figure 7).

FIGURE 7: KEYPAD/DONGLE SCHEMATIC

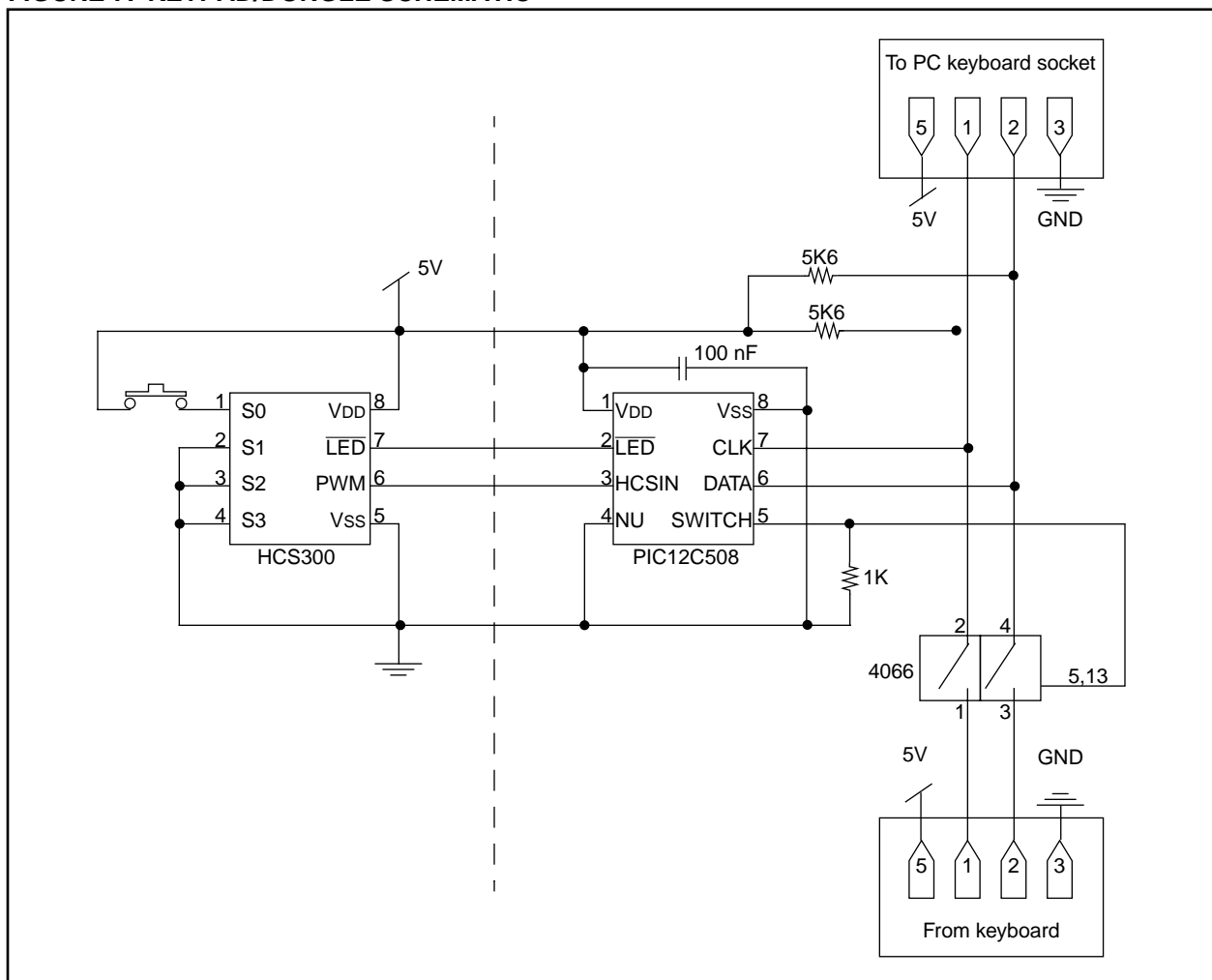

Software Implementation

The software is composed of three short code segments:

- Receive routine for the KEELOQ HCS300 Encoder
- Keyboard Emulation Routines
- Main loop routine.

Receive Routine for the HCS300 Encoder **(RECEIVE)**

The RECEIVE routine gathers the first 64 bits transmitted by the HCS300, ignoring the last two bits (repeat and battery status) as they carry no useful information for this application, and packs them into a 8-bytes buffer (Buffer0...Buffer7).

Keyboard Emulation Routines **(Sendbit, SendKey)**

These implement the transmission of the key scan codes according to the IBM-PC/AT keyboard protocol.

Main Loop

While the CMOS switch connects the PC to the keyboard clock and data lines, the $\overline{\text{LED}}$ output line is continuously polled to detect the activation of the HCS300

Note: Any combination of its four input lines after debouncing activates the encoder.

When the $\overline{\text{LED}}$ line goes low, the CMOS switch is activated to isolate the clock and data lines from the keyboard. The RECEIVE routine is called.

Upon successfully receiving a transmission, a loop is entered where 16 hex digits from the receive buffer are transmitted as a sequence of key press and key release messages, separated by appropriate delays repetitively calling the SENDKEY subroutine.

The software has been developed in the simplest possible form and, therefore, is open to a number of optimizations. For example:

- The PIC12C508 could be put to “sleep” to further reduce power consumption.
- The encoder could be removable and its presence/activation should be properly detected.
- For simplicity, the presented RECEIVE routine requires a 400 μs transmission speed being configured in the encoder, while a more flexible multi-baud rate routine can be used as presented in various other application notes.
- A second code word could be compared with the first code word received to recognize transmission errors (although highly improbable when the encoder is wired to the PIC12508), since there is no decryption, there is no other means to tell that the transmission has not been corrupted.

Decoding Options

A code hopping password can be used to validate access to a wide variety of electronic services providing the recipient application (typically, it will be some software running on a server) is capable of following some simple decryption and verification steps. The fixed unencrypted part of the code (last 8 digits) can be used to identify the user (7 digits) and the function activated on the encoder (1 out of 15, corresponding to the last digit).

The hopping part has to be decrypted using the appropriate 64-bit decryption key. Depending on the desired level of security, many different key generation and management techniques can be adopted. For example, the key could be deduced by the User ID and a Manufacturer's Key, by the “seed” code of the encoder or could simply be a fixed 64-bit constant.

Learning techniques can also be applied so that the application actually autonomously acquires the required keys and builds a database of users, ID codes, and decryption keys. For a further analysis, consult the following literature:

- AN645 *PIC16C57 Based Code Hopping Security System* (DS00645)
- AN662 *KEELOQ Code Hopping Decoder Using Secure Learn* (DS00662)
- AN663 *KEELOQ Simple Code Hopping Decoder* (DS00663)
- TB001 *An Introduction to KeeLoq Code Hopping* (DS91000A)
- TB003 *An Introduction to KEELOQ Code Hopping* (DS91002A).

Please check the Microchip Worldwide Web at www.microchip.com for the latest version of the source code.

APPENDIX A: HOPPASW.LST

MPASM 01.40 Released

HOPPASW.ASM 2-20-1997 16:45:24

PAGE 1

```

LOC  OBJECT CODE      LINE SOURCE TEXT
VALUE

00001      LIST          n=0, c=132
00002      PROCESSOR     PIC12C508
00003      RADIX          HEX
00004
00005      ;* filename: HOPPASW.ASM
00006      ;*****
00007      ;*      Author:          Lucio Di Jasio
00008      ;*      Company:        Microchip Technology
00009      ;*      Revision:       RevA0
00010      ;*      Date:          4-sept-96
00011      ;*      Assembled using: MPASM rev. 1.40
00012      ;*****
00013      ;*      include files:
00014      ;*          p12c508.inc
00015      ;*
00016      ;*****
00017      ;*      HCS300 to keyboard interface, for hopping password generation
00018      ;*
00019      ;*          /                /
00020      ;*      HCS300 |5V                |5V
00021      ;*      +-----+ |                | +-----+
00022      ;* Key1--+S1    +-+                +-+Vdd    +-----GND
00023      ;* Key2--+S2    LED+-----+LED    +-----PCCLK
00024      ;* Key3--+S3    PWM+-----+HCSIN  +-----DATA
00025      ;* Key4--+S4    +-+                -+nc    +-----SWITCH
00026      ;*      +-----+ |                +-----+
00027      ;*          |
00028      ;*          VGnd
00029      ;*
00030      ;*****
00031
00032      INCLUDE "\pic\include\p12c508.inc"
00001      LIST
00002      ; P12C508.INC Standard Header File, Vers 1.01 Microchip Technology. Inc.
00103      LIST
00033
00FF 0FEA      00034      __CONFIG _IntRC_OSC & _MCLRE_OFF & _CP_OFF & _WDT_OFF
01FF 0000 0003 0001 00035      __IDLOCS H'0312'
0002

00036
00037      ;*****
00038      ;* internal 4MHz clock
00039      ;* internal reset
00040      ;* no code protect (?)
00041      ;* no watchdog
00042      ;* ID code is "0312"
00043      ;*****
00044
00045      ;
00046      ; pin description
00047      ;
00048      #define LED          GPIO,5          ; Led from HCS300

```

```

00049 #define HCSIN      GPIO,4      ; PWM from HCS300
00050 #define NC         GPIO,3      ; not used
00051 #define SWITCH     GPIO,2      ; sense clock line to/from PC
00052 #define DATA      GPIO,1      ; data to PC
00053
00054 #define PCCLK        0           ; clock to PC
00055
00056 #define MASKDEF     b'11111011' ; only SWITCH pin in output
00057 #define MASKLOW     b'11111001' ; prepare data low
00058 #define MASKHIGH    b'11111011' ; prepare data high
00059
00060 ;
00061 ; RAM assignments
00062 ;
00063      CBLOCK 07
0000007 00064      BUFFER0          ; receive buffer for hcs300
0000008 00065      BUFFER1
0000009 00066      BUFFER2
000000A 00067      BUFFER3
000000B 00068      BUFFER4
000000C 00069      BUFFER5
000000D 00070      BUFFER6
000000E 00071      BUFFER7
000000F 00072      BITCOUNT        ; counters
0000010 00073      BYTECOUNT       ;
0000011 00074      TIMEHI           ; timing
0000012 00075      TIMELO          ;
0000013 00076      PARITY           ; transmission parity bit
0000014 00077      AUX              ; g.p.
0000015 00078      KEY              ; key to encode
0000016 00079      GPIOTEMP         ; temp copy of tris register
00080      ENDC
00081 ;-----
00082
0000      00083      ORG      0
00084
0000      00085 Start
0000 0025      00086      movwf  OSCCAL      ; calibrate
0001 0A7A      00087      goto   Main
00088
00089 ;-----
00090 ; keyscan table
00091 ;
0002      00092 ScanCode
0002 01E2      00093      addwf  PCL,F
0003 0845      00094      retlw  45          ; key '0'
0004 0816      00095      retlw  16          ; key '1'
0005 081E      00096      retlw  1E          ; key '2'
0006 0826      00097      retlw  26          ; key '3'
0007 0825      00098      retlw  25          ; key '4'
0008 082E      00099      retlw  2E          ; key '5'
0009 0836      00100      retlw  36          ; key '6'
000A 083D      00101      retlw  3D          ; key '7'
000B 083E      00102      retlw  3E          ; key '8'
000C 0846      00103      retlw  46          ; key '9'
000D 081C      00104      retlw  1C          ; key 'A'
000E 0832      00105      retlw  32          ; key 'B'
000F 0821      00106      retlw  21          ; key 'C'
0010 0823      00107      retlw  23          ; key 'D'
0011 0824      00108      retlw  24          ; key 'E'
0012 082B      00109      retlw  2B          ; key 'F'
00110
00111 #define      BREAK  0F0          ; break scan code
00112
00113 ;*****
00114 ;* SubDelay

```



```

00115 ;*      short delay functions N us
00116 ;*
00117 ;*      Input Variables:
00118 ;*          none
00119 ;*      Output Variables:
00120 ;*          none
00121 ;*****
00122 ;
0013 0000    00123 SubDelay10    nop
0014 0000    00124 SubDelay9     nop
0015 0000    00125 SubDelay8     nop
0016 0000    00126 SubDelay7     nop
0017 0000    00127 SubDelay6     nop
0018 0000    00128 SubDelay5     nop
0019 0800    00129 SubDelay4     retlw    0          ; 2 call + N nop + 2 retlw
00130
00131 ;*****
00132 ;*      Wait10ms
00133 ;*          waits for approx 10ms
00134 ;*
00135 ;*      Input Variables:
00136 ;*          none
00137 ;*      Output Variables:
00138 ;*          none
00139 ;*****
00140 ;
001A        00141 Wait10ms
001A 0C0F    00142                movlw    .15          ; 15 * .7ms ~= 10ms@4MHz
001B        00143 WaitWx750
001B 0031    00144                movwf    TIMEHI
001C        00145 WaitHi
001C 0072    00146                clrfsz   TIMELO          ; 256 * 3us ~= 750us@4MHz
001D        00147 WaitLo
001D 02F2    00148                decfsz   TIMELO,F
001E 0A1D    00149                goto     WaitLo
001F 02F1    00150                decfsz   TIMEHI,F
0020 0A1C    00151                goto     WaitHi
0021 0800    00152                retlw    0
00153
00154 ;*****
00155 ;*      SendBit
00156 ;*          sends a bit in AT keyboard protocol
00157 ;*
00158 ;*      Input Variables:
00159 ;*          STATUS,C
00160 ;*      Output Variables:
00161 ;*          none
00162 ;*****
00163 ;
0022        00164 SendBit
0022 0066    00165                clrfsz   GPIO          ; disable kb and clear out buffers
0023 0CF9    00166                movlw    MASKLOW       ; DATA low prepare
0024 0603    00167                btfsc   STATUS,C
0025 0CFB    00168                movlw    MASKHIGH     ; DATA high prepare
0026 0036    00169                movwf   GPIOTEMP      ; save value
0027 0006    00170                tris    GPIO
00171
0028 0C0E    00172                movlw    .14
0029 0032    00173                movwf   TIMELO
002A        00174 SBitT
002A 02F2    00175                decfsz   TIMELO,F      ; 45us loop (data stable)
002B 0A2A    00176                goto     SBitT
00177
002C 0416    00178                bcf     GPIOTEMP,PCCLK ; clk fall
002D 0216    00179                movf    GPIOTEMP,W
002E 0006    00180                tris    GPIO

```

AN665

```
00181
002F 0C0F      00182      movlw    .15
0030 0032      00183      movwf   TIMELO
0031           00184 SBitT2
0031 02F2      00185      decfsz  TIMELO,F      ; 45us loop (data stable)
0032 0A31      00186      goto    SBitT2
00187
0033 0516      00188      bsf     GPIOTEMP,PCCLK ; clk rise
0034 0216      00189      movf   GPIOTEMP,W
0035 0006      00190      tris   GPIO
0036 0800      00191      retlw   0
00192
00193 ;*****
00194 ;*   SendKEY
00195 ;*       sends a scan code to the PC
00196 ;*
00197 ;*       Input Variables:
00198 ;*           W
00199 ;*       Output Variables:
00200 ;*           none
00201 ;*****
00202 ;
0037           00203 SendKEY
0037 0034      00204      movwf   AUX          ; temp storage
00205
00206 ; wait PC ready
0038           00207 SendW
0038 0706      00208      btfss  GPIO,PCCLK   ; test PCCLK
0039 0A38      00209      goto    SendW        ; loop until HIGH
00210
00211 ; PC request ?
00212 ;       btfss  DATA      ; PC pull down Data?
00213 ;       goto    RecKEY    ; go receive first
00214
00215 ; send start bit
003A 0403      00216      bcf     STATUS,C
003B 0922      00217      call    SendBit
00218
00219 ; than shift out 8 bit LSB first
003C 0C08      00220      movlw   .8
003D 002F      00221      movwf   BITCOUNT
003E 0073      00222      clrf   PARITY
00223
003F           00224 SBitL
003F 0334      00225      rrf     AUX,F        ; next bit
0040 0603      00226      btfsc  STATUS,C
0041 02B3      00227      incf   PARITY,F      ; count parity
0042 0922      00228      call    SendBit
0043 02EF      00229      decfsz BITCOUNT,F
0044 0A3F      00230      goto    SBitL        ; loop for 8 bit
00231
0045 02B3      00232      incf   PARITY,F      ; parity odd
0046 0333      00233      rrf     PARITY,F      ; send parity Bit
0047 0922      00234      call    SendBit
00235
0048 0503      00236      bsf     STATUS,C
0049 0A22      00237      goto    SendBit      ; send stop bit (high = released)
00238
00239
00240 ;*****
00241 ;*   Receive
00242 ;*       receives first 64 bit transmitted by an HCS300 encoder
00243 ;*       simplified to operate with 400us PWM only
00244 ;*
00245 ;*       Input Variables:
00246 ;*           none
```

```

00247 ;*      Output Variables:
00248 ;*      BUFFER0..7
00249 ;*****
00250 ;
004A      00251 Receive
004A 0686      00252      btfsc   HCSIN           ; wait for a falling edge
004B 0A4A      00253      goto    Receive
00254
00255 ; will accept sync pulses from 3.0 to 6.1 ms.
00256 ; more than 128 cycles but less than 256
00257 ; each cycle is 24 us @4MHz
00258 ;
00000038     00259 PREBIT    EQU    .56
00260
004C 006F     00261      clrf   BITCOUNT       ; init counter
004D      00262 Rise
004D 0686     00263      btfsc   HCSIN           ; wait rising edge
004E 0A54     00264      goto    Rise2
00265
004F 0913     00266      call   SubDelay10      ; 24us per cycle
0050 0914     00267      call   SubDelay9       ;
00268
0051 03EF     00269      incfsz BITCOUNT,F    ; more than 6,0ms timeout
0052 0A4D     00270      goto   Rise           ; waiting loop
0053 0A4A     00271      goto   Receive        ; timeout restart
00272
0054      00273 Rise2
0054 07EF     00274      btfss  BITCOUNT,7    ; if bit7=1 ok
0055 0A4A     00275      goto   Receive        ; else less than 3.0 ms timeout
00276
00277 ;-----
00278 ; read following 8 bytes (ignore last 2 bit)
00279 ;
0056 0C40     00280      movlw  .64            ; 8 bit per byte
0057 002F     00281      movwf  BITCOUNT     ;
00282
0058      00283 FirstPreload
0058 0C38     00284      movlw  PREBIT        ; first bit needs no balance
0059 0031     00285      movwf  TIMEHI
005A 0A5D     00286      goto   WHL
00287
005B      00288 RNextBit
005B 0C36     00289      movlw  PREBIT-2      ; preload counter
005C 0031     00290      movwf  TIMEHI        ; balance extra rrf time
00291
005D      00292 WHL
005D 02B1     00293      incf   TIMEHI,F      ; measure high period
005E 0643     00294      btfsc  STATUS,Z
005F 0A4A     00295      goto   Receive       ; after 1.2ms (200*6) timeout
0060 0686     00296      btfsc  HCSIN         ; loop while High
0061 0A5D     00297      goto   WHL           ;
00298
0062 0C38     00299      movlw  PREBIT        ; preload counter
0063 0032     00300      movwf  TIMELO
00301
0064      00302 WLL
0064 02B2     00303      incf   TIMELO,F      ; measure low period
0065 0643     00304      btfsc  STATUS,Z
0066 0A4A     00305      goto   Receive       ; after 1.2ms (200*6) timeout
0067 0786     00306      btfss  HCSIN         ; loop while Low
0068 0A64     00307      goto   WLL
00308
00309 ; shift in the new bit
0069 0211     00310      movf   TIMEHI,W
006A 00B2     00311      subwf  TIMELO,F      ; if TIMEHI > TIMELO Carry = 0
006B 032E     00312      rrf    BUFFER7,F     ; insert bit in buffer

```

AN665

```
006C 032D      00313      rrf      BUFFER6,F
006D 032C      00314      rrf      BUFFER5,F
006E 032B      00315      rrf      BUFFER4,F
006F 032A      00316      rrf      BUFFER3,F
0070 0329      00317      rrf      BUFFER2,F
0071 0328      00318      rrf      BUFFER1,F
0072 0327      00319      rrf      BUFFER0,F
00320
00321 ; compare duty cycle, to skip preamble
0073 0CE0      00322      movlw   0E0          ; test duty cycle
0074 0152      00323      andwf   TIMELO,W    ; delta >200us? (32 cycles)
0075 0643      00324      btfsc  STATUS,Z
0076 0A4A      00325      goto   Receive      ; no! it's a preamble
00326
0077 02EF      00327      decfsz BITCOUNT,F  ; loop to completion
0078 0A5B      00328      goto   RNextBit
0079 0800      00329      retlw  0
00330
00331 ;-----
00332 ;*****
00333 ;* Main loop
00334 ;*   set TRIS and option register
00335 ;*   wait for start (LED)
00336 ;*   disable keyboard
00337 ;*   receive new hopping code
00338 ;*   send 16 hex digits
00339 ;*   wait transmission end
00340 ;*   loop
00341 ;*****
00342 ;
007A      00343 Main
007A 0C04      00344      movlw  b'00000100' ; set switch ON
007B 0026      00345      movwf  GPIO
007C 0CFB      00346      movlw  MASKDEF     ; init port
007D 0006      00347      tris   GPIO
007E 0C00      00348      movlw  0
007F 0002      00349      option
00350
0080 06A6      00351      btfsc  LED          ; wait for Led output fall
0081 0A7A      00352      goto   Main
00353
0082      00354 Disable
0082 0066      00355      clrf   GPIO          ; send disable kb
00356      ; SWITCH = LOW
00357
0083 094A      00358      call  Receive      ; gets the new hopping code
00359
00360 ;-----
00361 ; emulate a keyboard and send data as a sequence of 16 key
00362 ; pressed and released, one each hex digit
00363 ;
0084 0C08      00364      movlw  .8           ; 8 byte from the buffer
0085 0030      00365      movwf  BYTECOUNT
0086 0C07      00366      movlw  BUFFER0      ; init pointer
0087 0024      00367      movwf  FSR
00368
0088      00369 KEYL
0088 0200      00370      movf   INDF,W       ; low nibble
0089 0E0F      00371      andlw  0F
008A 0902      00372      call  ScanCode     ; encode hex nibble
008B 0035      00373      movwf  KEY
008C 0937      00374      call  SendKEY      ; emulate key press
008D 091A      00375      call  Wait10ms
008E 0CF0      00376      movlw  BREAK       ; emulate key release
008F 0937      00377      call  SendKEY
0090 0C01      00378      movlw  1
```

```

0091 091B      00379      call    WaitWx750      ; wait 750us
0092 0215      00380      movf    KEY,W
0093 0937      00381      call    SendKEY
                                00382
0094 091A      00383      call    Wait10ms
                                00384
0095 0380      00385      swapf  INDF,W          ; high nibble
0096 0E0F      00386      andlw  0F
0097 0902      00387      call    ScanCode      ; encode hex nibble
0098 0035      00388      movwf  KEY
0099 0937      00389      call    SendKEY       ; emulate key press
009A 091A      00390      call    Wait10ms
009B 0CF0      00391      movlw  BREAK         ; emulate key release
009C 0937      00392      call    SendKEY
009D 0C01      00393      movlw  1
009E 091B      00394      call    WaitWx750     ; wait 750us
009F 0215      00395      movf    KEY,W
00A0 0937      00396      call    SendKEY
                                00397
00A1 091A      00398      call    Wait10ms
                                00399
00A2 02A4      00400      incf   FSR,F          ; next byte
00A3 02F0      00401      decfsz BYTECOUNT,F
00A4 0A88      00402      goto   KEYL
                                00403
                                00404 ;-----
00405 ; now wait for the HCS to stop transmission (button release)
00406 ;
00A5          00407 Release
00A5 07A6      00408      btfss  LED            ; wait Led rise
00A6 0AA5      00409      goto   Release
00A7 0A7A      00410      goto   Main
                                00411
                                00412      END

```

MPASM 01.40 Released HOPPASW.ASM 2-20-1997 16:45:24 PAGE 2

MEMORY USAGE MAP ('X' = Used, '-' = Unused)

```

0000 : XXXXXXXXXXXXXXXXXXXX XXXXXXXXXXXXXXXXXXXX XXXXXXXXXXXXXXXXXXXX XXXXXXXXXXXXXXXXXXXX
0040 : XXXXXXXXXXXXXXXXXXXX XXXXXXXXXXXXXXXXXXXX XXXXXXXXXXXXXXXXXXXX XXXXXXXXXXXXXXXXXXXX
0080 : XXXXXXXXXXXXXXXXXXXX XXXXXXXXXXXXXXXXXXXX XXXXXXXX-----
01C0 : -----X
0200 : XXX-----
0FC0 : -----X

```

All other memory blocks unused.

```

Program Memory Words Used:  168
Program Memory Words Free:  343

```

```

Errors    :    0
Warnings :    0 reported,    0 suppressed
Messages :    0 reported,    0 suppressed

```

AN665

NOTES:

NOTES:

Note the following details of the code protection feature on PICmicro® MCUs.

- The PICmicro family meets the specifications contained in the Microchip Data Sheet.
- Microchip believes that its family of PICmicro microcontrollers is one of the most secure products of its kind on the market today, when used in the intended manner and under normal conditions.
- There are dishonest and possibly illegal methods used to breach the code protection feature. All of these methods, to our knowledge, require using the PICmicro microcontroller in a manner outside the operating specifications contained in the data sheet. The person doing so may be engaged in theft of intellectual property.
- Microchip is willing to work with the customer who is concerned about the integrity of their code.
- Neither Microchip nor any other semiconductor manufacturer can guarantee the security of their code. Code protection does not mean that we are guaranteeing the product as “unbreakable”.
- Code protection is constantly evolving. We at Microchip are committed to continuously improving the code protection features of our product.

If you have any further questions about this matter, please contact the local sales office nearest to you.

Information contained in this publication regarding device applications and the like is intended through suggestion only and may be superseded by updates. It is your responsibility to ensure that your application meets with your specifications. No representation or warranty is given and no liability is assumed by Microchip Technology Incorporated with respect to the accuracy or use of such information, or infringement of patents or other intellectual property rights arising from such use or otherwise. Use of Microchip's products as critical components in life support systems is not authorized except with express written approval by Microchip. No licenses are conveyed, implicitly or otherwise, under any intellectual property rights.

Trademarks

The Microchip name and logo, the Microchip logo, FilterLab, KEELOQ, microID, MPLAB, PIC, PICmicro, PICMASTER, PICSTART, PRO MATE, SEEVAL and The Embedded Control Solutions Company are registered trademarks of Microchip Technology Incorporated in the U.S.A. and other countries.

dsPIC, ECONOMONITOR, FanSense, FlexROM, fuzzyLAB, In-Circuit Serial Programming, ICSP, ICEPIC, microPort, Migratable Memory, MPASM, MPLIB, MPLINK, MPSIM, MXDEV, PICC, PICDEM, PICDEM.net, rPIC, Select Mode and Total Endurance are trademarks of Microchip Technology Incorporated in the U.S.A.

Serialized Quick Turn Programming (SQTP) is a service mark of Microchip Technology Incorporated in the U.S.A.

All other trademarks mentioned herein are property of their respective companies.

© 2002, Microchip Technology Incorporated, Printed in the U.S.A., All Rights Reserved.

 Printed on recycled paper.



Microchip received QS-9000 quality system certification for its worldwide headquarters, design and wafer fabrication facilities in Chandler and Tempe, Arizona in July 1999. The Company's quality system processes and procedures are QS-9000 compliant for its PICmicro® 8-bit MCUs, KEELOQ® code hopping devices, Serial EEPROMs and microperipheral products. In addition, Microchip's quality system for the design and manufacture of development systems is ISO 9001 certified.



MICROCHIP

WORLDWIDE SALES AND SERVICE

AMERICAS

Corporate Office

2355 West Chandler Blvd.
Chandler, AZ 85224-6199
Tel: 480-792-7200 Fax: 480-792-7277
Technical Support: 480-792-7627
Web Address: <http://www.microchip.com>

Rocky Mountain

2355 West Chandler Blvd.
Chandler, AZ 85224-6199
Tel: 480-792-7966 Fax: 480-792-7456

Atlanta

500 Sugar Mill Road, Suite 200B
Atlanta, GA 30350
Tel: 770-640-0034 Fax: 770-640-0307

Boston

2 Lan Drive, Suite 120
Westford, MA 01886
Tel: 978-692-3848 Fax: 978-692-3821

Chicago

333 Pierce Road, Suite 180
Itasca, IL 60143
Tel: 630-285-0071 Fax: 630-285-0075

Dallas

4570 Westgrove Drive, Suite 160
Addison, TX 75001
Tel: 972-818-7423 Fax: 972-818-2924

Detroit

Tri-Atria Office Building
32255 Northwestern Highway, Suite 190
Farmington Hills, MI 48334
Tel: 248-538-2250 Fax: 248-538-2260

Kokomo

2767 S. Albright Road
Kokomo, Indiana 46902
Tel: 765-864-8360 Fax: 765-864-8387

Los Angeles

18201 Von Karman, Suite 1090
Irvine, CA 92612
Tel: 949-263-1888 Fax: 949-263-1338

New York

150 Motor Parkway, Suite 202
Hauppauge, NY 11788
Tel: 631-273-5305 Fax: 631-273-5335

San Jose

Microchip Technology Inc.
2107 North First Street, Suite 590
San Jose, CA 95131
Tel: 408-436-7950 Fax: 408-436-7955

Toronto

6285 Northam Drive, Suite 108
Mississauga, Ontario L4V 1X5, Canada
Tel: 905-673-0699 Fax: 905-673-6509

ASIA/PACIFIC

Australia

Microchip Technology Australia Pty Ltd
Suite 22, 41 Rawson Street
Epping 2121, NSW
Australia
Tel: 61-2-9868-6733 Fax: 61-2-9868-6755

China - Beijing

Microchip Technology Consulting (Shanghai)
Co., Ltd., Beijing Liaison Office
Unit 915
Bei Hai Wan Tai Bldg.
No. 6 Chaoyangmen Beidajie
Beijing, 100027, No. China
Tel: 86-10-85282100 Fax: 86-10-85282104

China - Chengdu

Microchip Technology Consulting (Shanghai)
Co., Ltd., Chengdu Liaison Office
Rm. 2401, 24th Floor,
Ming Xing Financial Tower
No. 88 TIDU Street
Chengdu 610016, China
Tel: 86-28-6766200 Fax: 86-28-6766599

China - Fuzhou

Microchip Technology Consulting (Shanghai)
Co., Ltd., Fuzhou Liaison Office
Unit 28F, World Trade Plaza
No. 71 Wusi Road
Fuzhou 350001, China
Tel: 86-591-7503506 Fax: 86-591-7503521

China - Shanghai

Microchip Technology Consulting (Shanghai)
Co., Ltd.
Room 701, Bldg. B
Far East International Plaza
No. 317 Xian Xia Road
Shanghai, 200051
Tel: 86-21-6275-5700 Fax: 86-21-6275-5060

China - Shenzhen

Microchip Technology Consulting (Shanghai)
Co., Ltd., Shenzhen Liaison Office
Rm. 1315, 13/F, Shenzhen Kerry Centre,
Renminnan Lu
Shenzhen 518001, China
Tel: 86-755-2350361 Fax: 86-755-2366086

Hong Kong

Microchip Technology Hongkong Ltd.
Unit 901-6, Tower 2, Metroplaza
223 Hing Fong Road
Kwai Fong, N.T., Hong Kong
Tel: 852-2401-1200 Fax: 852-2401-3431

India

Microchip Technology Inc.
India Liaison Office
Divyasree Chambers
1 Floor, Wing A (A3/A4)
No. 11, O'Shaugnessey Road
Bangalore, 560 025, India
Tel: 91-80-2290061 Fax: 91-80-2290062

Japan

Microchip Technology Japan K.K.
Benex S-1 6F
3-18-20, Shinyokohama
Kohoku-Ku, Yokohama-shi
Kanagawa, 222-0033, Japan
Tel: 81-45-471- 6166 Fax: 81-45-471-6122

Korea

Microchip Technology Korea
168-1, Youngbo Bldg. 3 Floor
Samsung-Dong, Kangnam-Ku
Seoul, Korea 135-882
Tel: 82-2-554-7200 Fax: 82-2-558-5934

Singapore

Microchip Technology Singapore Pte Ltd.
200 Middle Road
#07-02 Prime Centre
Singapore, 188980
Tel: 65-334-8870 Fax: 65-334-8850

Taiwan

Microchip Technology Taiwan
11F-3, No. 207
Tung Hua North Road
Taipei, 105, Taiwan
Tel: 886-2-2717-7175 Fax: 886-2-2545-0139

EUROPE

Denmark

Microchip Technology Nordic ApS
Regus Business Centre
Lautrup høj 1-3
Ballerup DK-2750 Denmark
Tel: 45 4420 9895 Fax: 45 4420 9910

France

Microchip Technology SARL
Parc d'Activite du Moulin de Massy
43 Rue du Saule Trapu
Batiment A - 1er Etage
91300 Massy, France
Tel: 33-1-69-53-63-20 Fax: 33-1-69-30-90-79

Germany

Microchip Technology GmbH
Gustav-Heinemann Ring 125
D-81739 Munich, Germany
Tel: 49-89-627-144 0 Fax: 49-89-627-144-44

Italy

Microchip Technology SRL
Centro Direzionale Colleoni
Palazzo Taurus 1 V. Le Colleoni 1
20041 Agrate Brianza
Milan, Italy
Tel: 39-039-65791-1 Fax: 39-039-6899883

United Kingdom

Arizona Microchip Technology Ltd.
505 Eskdale Road
Winnersh Triangle
Wokingham
Berkshire, England RG41 5TU
Tel: 44 118 921 5869 Fax: 44-118 921-5820

01/18/02