

International  
**IR** Rectifier

Integrated Power Hybrid IC for  
Appliance Motor Drive Applications

**IRAM136-1060B**  
**iMOTION™ Series**

**10A, 600V**  
**with Internal Shunt Resistor**

### Description

International Rectifier's IRAM136-1060B is a 10A, 600V Integrated Power Hybrid IC designed for advanced Appliance Motor Drives applications. Typical applications include energy efficient Washing Machine, Fans, Air Conditions and Refrigerator Compressor Drivers. This module offers an extremely compact, high performance AC motor-driver in an isolated package that simplifies design. Several built-in protection features such as over current, temperature monitoring, shoot through prevention and under voltage lockout makes this a very robust solution. The combination of highly efficient Trench IGBT technology and the industry benchmark 3-phase HVIC driver (3.3V/5V input compatible) and a fully isolated thermally enhanced package makes this a highly competitive solution. The compact Single in line (SIP05) package minimizes PCB space.

### Features

- Internal Shunt Resistor and current feedback
- Integrated gate drivers and bootstrap diodes
- Temperature feedback
- Programmable over current protection pin
- High efficiency Trench IGBT technology
- Under-voltage lockout for all channels
- Matched propagation delay for all channels
- 3.3V/5V Schmitt-triggered input logic
- Cross-conduction prevention logic
- Motor Power range 0.25~0.75kW / 85~253 Vac
- Isolation 2000V<sub>RMS</sub> min and CTI> 600



### Absolute Maximum Ratings

$V_{CES} / V_{RRM}$	IGBT/ FW Diode Blocking Voltage	600	V
$V^+$	Positive Bus Input Voltage	450	
$I_o @ T_C=25^{\circ}C$	RMS Phase Current (Note 1)	10	A
$I_o @ T_C=100^{\circ}C$	RMS Phase Current (Note 1)	5	
$I_{pk}$	Maximum Peak Phase Current (Note 2)	13	
$F_p$	Maximum PWM Carrier Frequency	20	kHz
$P_d$	Maximum Power dissipation per IGBT @ $T_C = 25^{\circ}C$	25	W
$V_{ISO}$	Isolation Voltage (1min)	2000	$V_{RMS}$
$T_J$ (IGBT & Diode & IC)	Maximum Operating Junction Temperature	+150	$^{\circ}C$
$T_C$	Operating Case Temperature Range	-20 to +100	
$T_{STG}$	Storage Temperature Range	-40 to +125	
$T$	Mounting torque Range (M3 screw)	0.8 to 1.0	

Note 1: Sinusoidal Modulation at  $V^+=400V$ ,  $T_J=150^{\circ}C$ ,  $F_{PWM}=16kHz$ , Modulation Depth=0.8, PF=0.6, See Figure 3.

Note 2:  $t_p < 100ms$ ,  $T_C=25^{\circ}C$ ,  $F_{PWM}=16kHz$ .

# IRAM136-1060B

## Internal Electrical Schematic – IRAM136-1060B

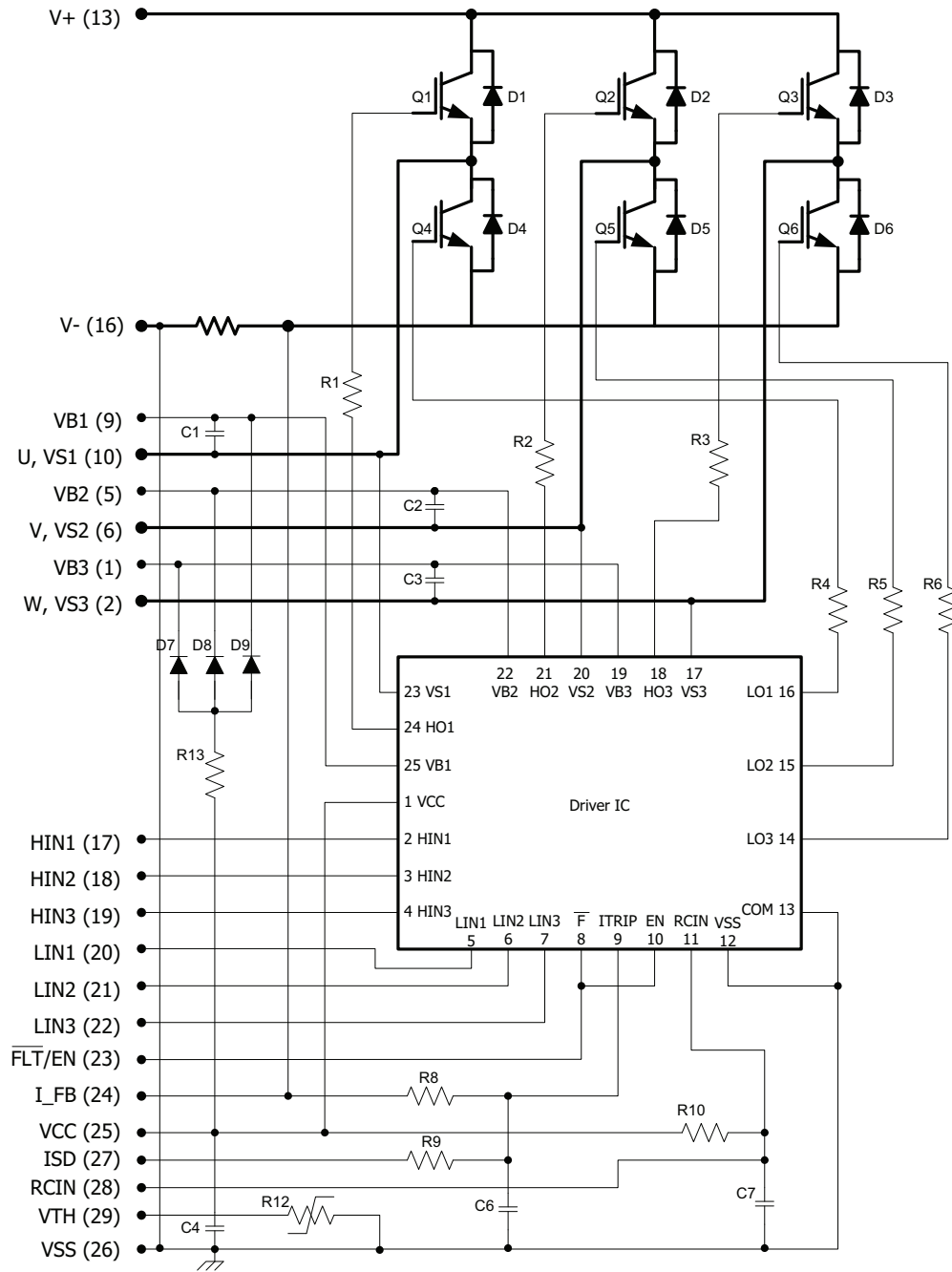

**Absolute Maximum Ratings (Continued)**

Symbol	Parameter	Min	Max	Units	Conditions
$P_{BR\ Peak}$	Bootstrap Resistor Peak Power (Single Pulse)	---	15.0	W	$t_p=100\mu s$ , $T_C=100^\circ C$ ESR / ERJ series
$V_{S1,2,3}$	High side floating supply offset voltage	$V_{B1,2,3} - 25$	$V_{B1,2,3} + 0.3$	V	
$V_{B1,2,3}$	High side floating supply voltage	-0.3	600	V	
$V_{CC}$	Low Side and logic fixed supply voltage	-0.3	20	V	
$V_{IN}$	Input voltage LIN, HIN, $I_{TRIP}$	-0.3	Lower of ( $V_{SS}+15V$ ) or $V_{CC}+0.3V$	V	

**Inverter Section Electrical Characteristics @ $T_J=25^\circ C$**

Symbol	Parameter	Min	Typ	Max	Units	Conditions
$V_{(BR)CES}$	Collector-to-Emitter Breakdown Voltage	600	---	---	V	$V_{IN}=0V$ , $I_C=250\mu A$
$\Delta V_{(BR)CES} / \Delta T$	Temperature Coeff. Of Breakdown Voltage	---	0.3	---	V/ $^\circ C$	$V_{IN}=0V$ , $I_C=250\mu A$ ( $25^\circ C - 150^\circ C$ )
$V_{CE(ON)}$	Collector-to-Emitter Saturation Voltage	---	1.5	1.7	V	$I_C=5A$ , $T_J=25^\circ C$
		---	1.7	---		$I_C=5A$ , $T_J=150^\circ C$
$I_{CES}$	Zero Gate Voltage Collector Current	---	5	80	$\mu A$	$V_{IN}=0V$ , $V^+=600V$
		---	80	---		$V_{IN}=0V$ , $V^+=600V$ , $T_J=150^\circ C$
$V_{FM}$	Diode Forward Voltage Drop	--	1.8	2.35	V	$I_F=5A$
		---	1.45	---		$I_F=5A$ , $T_J=150^\circ C$
$V_{BDFM}$	Bootstrap Diode Forward Voltage Drop	--	1.2	--	V	$I_F=1A$
$R_{BR}$	Bootstrap Resistor Value	---	22	---	$\Omega$	$T_J=25^\circ C$
$\Delta R_{BR}/R_{BR}$	Bootstrap Resistor Tolerance	---	---	$\pm 5$	%	$T_J=25^\circ C$
$I_{BUS\_TRIP}$	Current Protection Threshold (positive going)	---	20	---	A	ISD=Vss. See fig. 2 and fig. 11b
		---	15	---		ISD=Open. See fig. 2 and fig. 11b

## Inverter Section Switching Characteristics @ $T_j = 25^\circ\text{C}$

Symbol	Parameter	Min	Typ	Max	Units	Conditions
$E_{ON}$	Turn-On Switching Loss	---	240	400	$\mu\text{J}$	$I_C=5\text{A}$ , $V^+=400\text{V}$ $V_{CC}=15\text{V}$ , $L=1.2\text{mH}$ Energy losses include "tail" and diode reverse recovery
$E_{OFF}$	Turn-Off Switching Loss	---	65	90		
$E_{TOT}$	Total Switching Loss	---	305	490		
$E_{REC}$	Diode Reverse Recovery energy	---	15	25		
$t_{RR}$	Diode Reverse Recovery time	---	115	---	ns	See CT1
$E_{ON}$	Turn-on Switching Loss	---	330	---	$\mu\text{J}$	$I_C=5\text{A}$ , $V^+=400\text{V}$ $V_{CC}=15\text{V}$ , $L=1.2\text{mH}$ , $T_j=150^\circ\text{C}$ Energy losses include "tail" and diode reverse recovery
$E_{OFF}$	Turn-off Switching Loss	---	105	---		
$E_{TOT}$	Total Switching Loss	---	435	---		
$E_{REC}$	Diode Reverse Recovery energy	---	40	---		
$t_{RR}$	Diode Reverse Recovery time	---	150	---	ns	See CT1
$Q_G$	Turn-On IGBT Gate Charge	---	19	29	nC	$I_C=8\text{A}$ , $V^+=400\text{V}$ , $V_{GE}=15\text{V}$
RBSOA	Reverse Bias Safe Operating Area	FULL SQUARE				$T_j=150^\circ\text{C}$ , $I_C=5\text{A}$ , $V_p=600\text{V}$ $V^+=450\text{V}$ , $V_{CC}=+15\text{V}$ to $0\text{V}$ See CT3
SCSOA	Short Circuit Safe Operating Area	5	---	---	$\mu\text{s}$	$T_j=25^\circ\text{C}$ , $V_p=600\text{V}$ , $V^+=360\text{V}$ , $V_{CC}=+15\text{V}$ to $0\text{V}$ See CT2
$I_{CSC}$	Short Circuit Collector Current	---	50	---	A	$T_j=25^\circ\text{C}$ , $V^+=400\text{V}$ , $V_{CC}=15\text{V}$ See CT2

## Recommended Operating Conditions Driver Function

The Input/Output logic timing diagram is shown in Figure 1. For proper operation the device should be used within the recommended conditions. All voltages are absolute referenced to COM. The  $V_s$  offset is tested with all supplies biased at 15V differential (Note 3)

Symbol	Definition	Min	Typ	Max	Units
$V_{B1,2,3}$	High side floating supply voltage	$V_s+12$	$V_s+15$	$V_s+20$	V
$V_{S1,2,3}$	High side floating supply offset voltage	Note 4	---	450	
$V_{CC}$	Low side and logic fixed supply voltage	12	15	20	V
$V_{TRIP}$	$I_{TRIP}$ input voltage	$V_{SS}$	---	$V_{SS}+5$	
$V_{IN}$	Logic input voltage LIN, HIN	$V_{SS}$	---	$V_{SS}+5$	V
HIN	High side PWM pulse width	1	---	---	$\mu\text{s}$
Deadtime	External dead time between HIN and LIN	1	---	---	$\mu\text{s}$

Note 3: For more details, see IR21364 data sheet

Note 4: Logic operational for  $V_s$  from COM-5V to COM+600V. Logic state held for  $V_s$  from COM-5V to COM- $V_{BS}$ . (please refer to DT97-3 for more details)

## Static Electrical Characteristics Driver Function @ T<sub>J</sub>= 25°C

V<sub>BIAS</sub> (V<sub>CC</sub>, V<sub>BS1,2,3</sub>)=15V, unless otherwise specified. The V<sub>IN</sub> and I<sub>IN</sub> parameters are referenced to COM and are applicable to all six channels. (Note 3)

Symbol	Definition	Min	Typ	Max	Units
V <sub>IN,th+</sub>	Positive going input threshold	2.5	---	---	V
V <sub>IN,th-</sub>	Negative going input threshold	---	---	0.8	V
V <sub>CCUV+</sub> , V <sub>BSUV+</sub>	V <sub>CC</sub> and V <sub>BS</sub> supply undervoltage, Positive going threshold	10.6	11.1	11.6	V
V <sub>CCUV-</sub> , V <sub>BSUV-</sub>	V <sub>CC</sub> and V <sub>BS</sub> supply undervoltage, Negative going threshold	10.4	10.9	11.4	V
V <sub>CCUVH</sub> , V <sub>BSUVH</sub>	V <sub>CC</sub> and V <sub>BS</sub> supply undervoltage lock-out hysteresis	---	0.2	---	V
I <sub>QBS</sub>	Quiescent V <sub>BS</sub> supply current	---	---	120	μA
I <sub>QCC</sub>	Quiescent V <sub>CC</sub> supply current	---	---	4	mA
I <sub>LK</sub>	Offset Supply Leakage Current	---	---	50	μA
I <sub>IN+</sub>	Input bias current V <sub>IN</sub> =3.3V	---	100	195	μA
I <sub>IN-</sub>	Input bias current V <sub>IN</sub> =0V	-1	--	---	μA
I <sub>TRIP+</sub>	I <sub>TRIP</sub> bias current V <sub>T/ITRIP</sub> =3.3V	---	3.3	6	μA
I <sub>TRIP-</sub>	I <sub>TRIP</sub> bias current V <sub>T/ITRIP</sub> =0V	-1	---	---	μA
V(I <sub>TRIP</sub> )	I <sub>TRIP</sub> threshold Voltage	0.44	0.49	0.54	V
V(I <sub>TriP</sub> , HYS)	I <sub>TRIP</sub> Input Hysteresis	---	0.07	---	V

## Dynamic Electrical Characteristics @ T<sub>J</sub>= 25°C

Driver only timing unless otherwise specified.

Symbol	Parameter	Min	Typ	Max	Units	Conditions
T <sub>ON</sub>	Input to Output propagation turn-on delay time (see fig.11)	---	---	1.15	μs	I <sub>C</sub> =5A, V <sup>+</sup> =300V
T <sub>OFF</sub>	Input to Output propagation turn-off delay time (see fig. 11)	---	---	1.15	μs	
T <sub>FLT</sub>	Input Filter Time (HIN, LIN)	100	200	---	ns	V <sub>IN</sub> =0 or V <sub>IN</sub> =5V
T <sub>BLT-ITRIP</sub>	I <sub>TRIP</sub> Blanking Time	100	150	---	ns	V <sub>IN</sub> =0 or V <sub>IN</sub> =5V, V <sub>ITRIP</sub> =5V
D <sub>T</sub>	Dead Time	220	290	360	ns	V <sub>IN</sub> =0 or V <sub>IN</sub> =5V
M <sub>T</sub>	Matching Propagation Delay Time (On & Off) all channels	---	40	75	ns	External dead time > 400ns
T <sub>ITRIP</sub>	I <sub>TRIP</sub> to six switch turn-off propagation delay (see fig. 2)	---	---	1.75	μs	I <sub>C</sub> =5A, V <sup>+</sup> =300V
T <sub>FLT-CLR</sub>	FAULT clear time (see fig. 2)	---	32.0	---	ms	T <sub>C</sub> = 25°C

## Thermal and Mechanical Characteristics

Symbol	Parameter	Min	Typ	Max	Units	Conditions
$R_{th(J-C)}$	Thermal resistance, per IGBT	---	4.6	5.0	°C/W	Inverter Operating Condition Flat, greased surface. Heatsink compound thermal conductivity 1W/mK
$R_{th(J-C)}$	Thermal resistance, per Diode	---	6.9	7.6		
$R_{th(C-S)}$	Thermal resistance, C-S	---	0.1	---		
$C_D$	Creepage Distance, from pins to backside of module	3.2	---	---	mm	See outline Drawings
CTI	Comparative Tracking Index	600	---	---	-	

## Internal NTC - Thermistor Characteristics

Parameter	Definition	Min	Typ	Max	Units	Conditions
$R_{25}$	Resistance	97	100	103	k $\Omega$	$T_C = 25^\circ\text{C}$
$R_{125}$	Resistance	2.25	2.52	2.80	k $\Omega$	$T_C = 125^\circ\text{C}$
B	B-constant (25-50°C)	4165	4250	4335	k	$R_2 = R_1 e^{[B(1/T_2 - 1/T_1)]}$
Temperature Range		-40	---	125	°C	
Typ. Dissipation constant		---	1	---	mW/°C	$T_C = 25^\circ\text{C}$

## Internal Current Sensing Resistor - Shunt Characteristics

Symbol	Parameter	Min	Typ	Max	Units	Conditions
$R_{Shunt}$	Resistance	32.9	33.3	33.7	m $\Omega$	$T_C = 25^\circ\text{C}$
$T_{Coeff}$	Temperature Coefficient	0	---	200	ppm/°C	
$P_{Shunt}$	Power Dissipation	---	---	2.2	W	$-40^\circ\text{C} < T_C < 100^\circ\text{C}$
$T_{Range}$	Temperature Range	-40	---	125	°C	

## Input-Output Logic Level Table

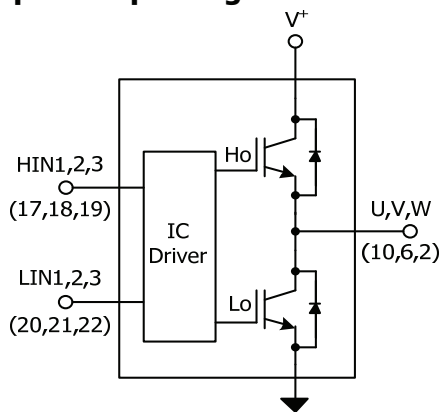

$\overline{\text{FLT/EN}}$	$I_{TRIP}$	HIN1,2,3	LIN1,2,3	U,V,W
1	0	1	0	V+
1	0	0	1	0
1	0	0	0	Off
1	0	1	1	Off
1	1	X	X	Off
0	X	X	X	Off

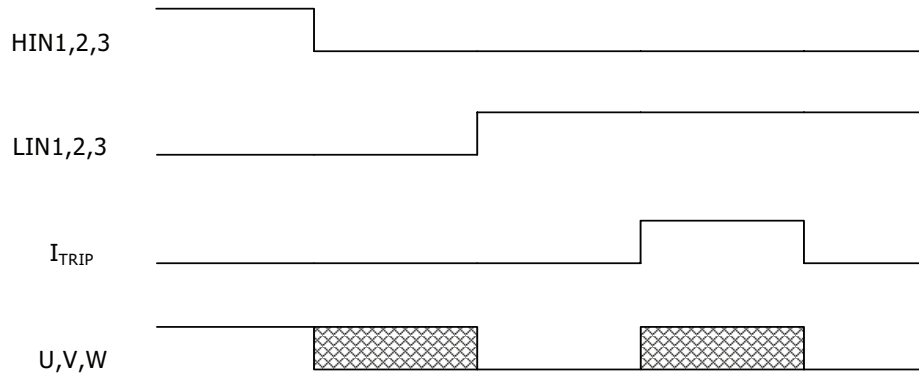

Figure 1. Input/Output Timing Diagram

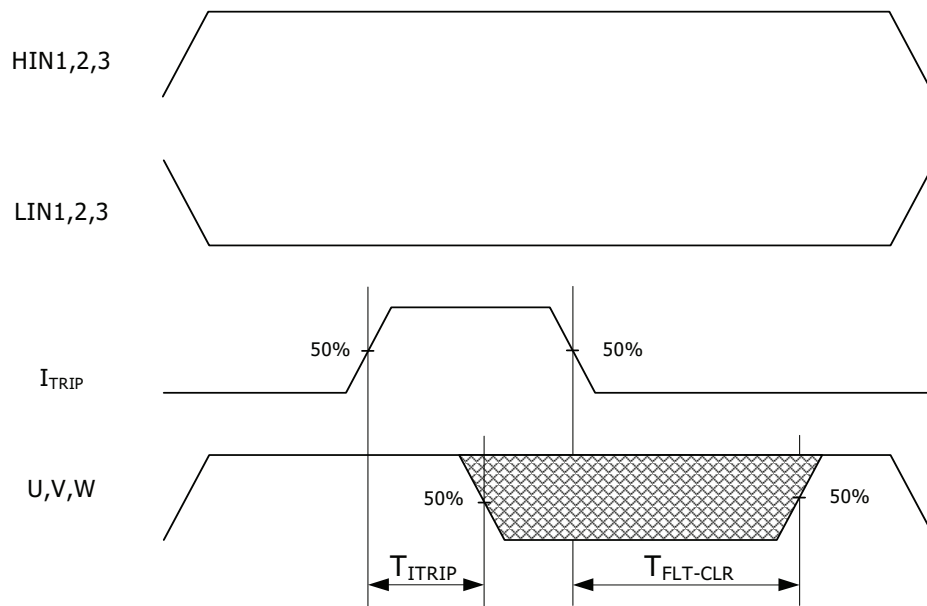

Figure 2.  $I_{TRIP}$  Timing Waveform

Note 5: The shaded area indicates that both high-side and low-side switches are off and therefore the half-bridge output voltage would be determined by the direction of current flow in the load.

## Module Pin-Out Description

Pin	Name	Description
1	VB3	High Side Floating Supply Voltage 3
2	W,VS3	Output 3 - High Side Floating Supply Offset Voltage
3	na	none
4	na	none
5	VB2	High Side Floating Supply voltage 2
6	V,VS2	Output 2 - High Side Floating Supply Offset Voltage
7	na	none
8	na	none
9	VB1	High Side Floating Supply voltage 1
10	U,VS1	Output 1 - High Side Floating Supply Offset Voltage
11	na	none
12	na	none
13	V <sup>+</sup>	Positive Bus Input Voltage
14	na	none
15	na	none
16	V <sup>-</sup>	Negative Bus Input Voltage
17	HIN1	Logic Input High Side Gate Driver - Phase 1
18	HIN2	Logic Input High Side Gate Driver - Phase 2
19	HIN3	Logic Input High Side Gate Driver - Phase 3
20	LIN1	Logic Input Low Side Gate Driver - Phase 1
21	LIN2	Logic Input Low Side Gate Driver - Phase 2
22	LIN3	Logic Input Low Side Gate Driver - Phase 3
23	FLT/EN	Fault Output and Enable Pins
24	I <sub>FB</sub>	Current Feedback Output Pin
25	V <sub>CC</sub>	+15V Main Supply
26	V <sub>SS</sub>	Negative Main Supply
27	ISD	Current Protection Level Programming Pin
28	RCIN	RCIN Reset Programming Pin
29	V <sub>TH</sub>	Temperature Feedback



## Typical Application Connection IRAM136-1060B

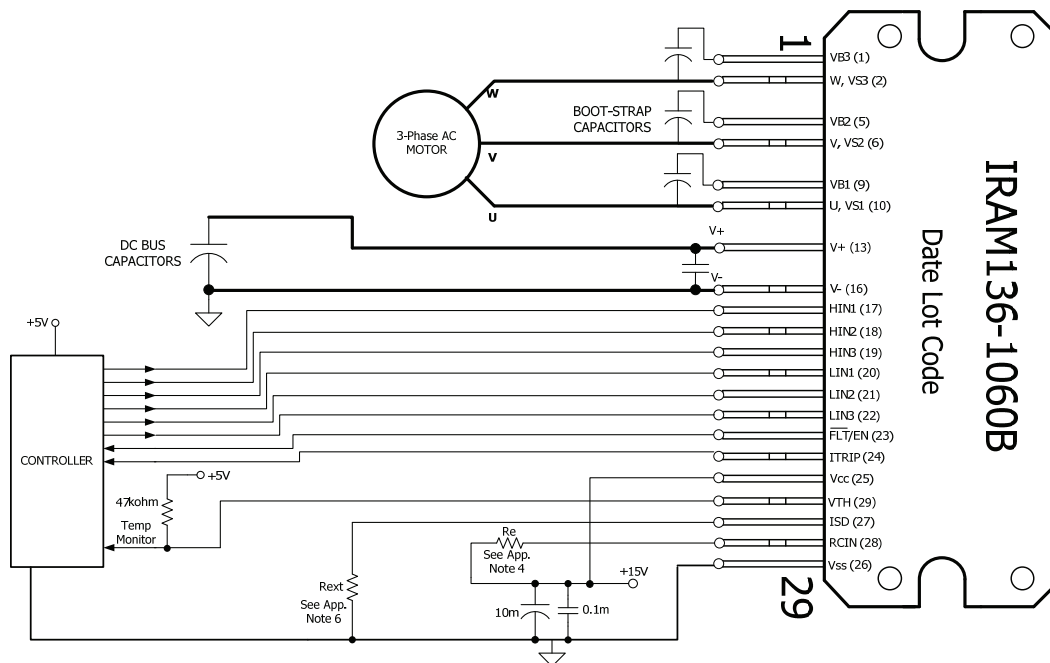

### Application Notes

1. Electrolytic bus capacitors should be mounted as close to the module bus terminals as possible to reduce ringing and EMI problems. Mounting an additional high frequency ceramic capacitor close to the module pins is highly recommended.
2. In order to provide good decoupling between VCC-VSS and VB1,2,3-VS1,2,3 terminals, the capacitors shown connected between these terminals should be located very close to the module pins. Additional high frequency capacitors, typically 0.1 $\mu$ F, are strongly recommended.
3. Value of the boot-strap capacitors depends upon the switching frequency and modulation techniques. Their selection should be made based on IR design tip DN 98-2a, application note AN-1044 or Figure 9. Bootstrap capacitor value must be selected to limit the power dissipation of the internal resistor in series with the VCC. (See maximum ratings Table on page 3).
4. **WARNING!** Please note that after approx. 32ms the FAULT is automatically reset. (See Dynamic Characteristics Table on page 5). The default Fault clear time is when RCIN pin is open. Refer to Figure 11a for Re selection and desired RCIN setting.
5. PWM generator must be disabled within automatic reset time ( $T_{FLT-CLR}$ ) to guarantee shutdown of the system, overcurrent condition must be cleared before resuming operation.
6. ISD can be programmed by using external resistor (Rext) connected to Vss. The default current level is when ISD pin is open (see Inverter Characteristics Table on page 3). Maximum current level can be achieved by connecting ISD to Vss. See Figure 11b for desired current level and resistor selection.
7. Fault/En pin (23) must be pulled-up to +5V.

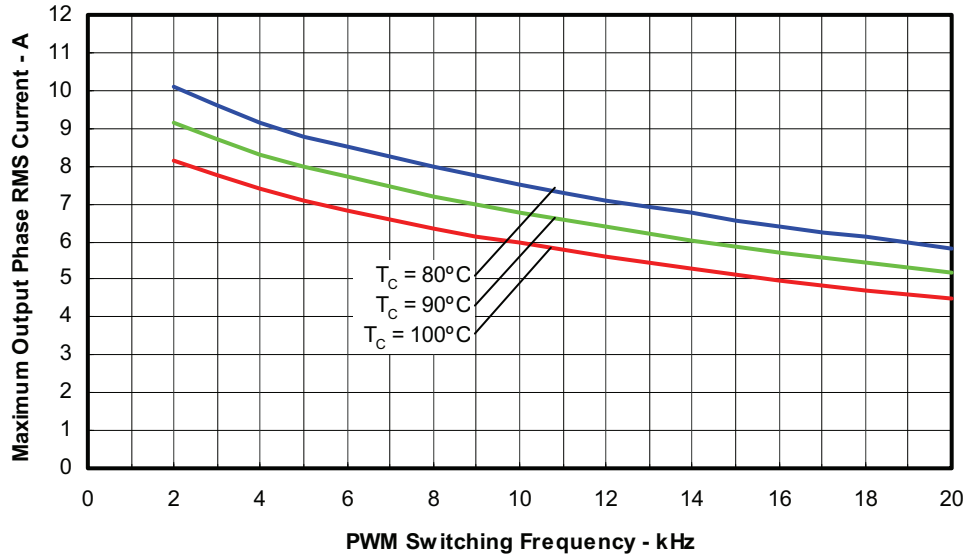

Figure 3. Maximum Sinusoidal Phase Current vs. PWM Switching Frequency Sinusoidal Modulation,  $V^+ = 400\text{V}$ ,  $T_j = 150^\circ\text{C}$ ,  $MI = 0.8$ ,  $PF = 0.6$ ,  $f_{mod} = 100\text{Hz}$

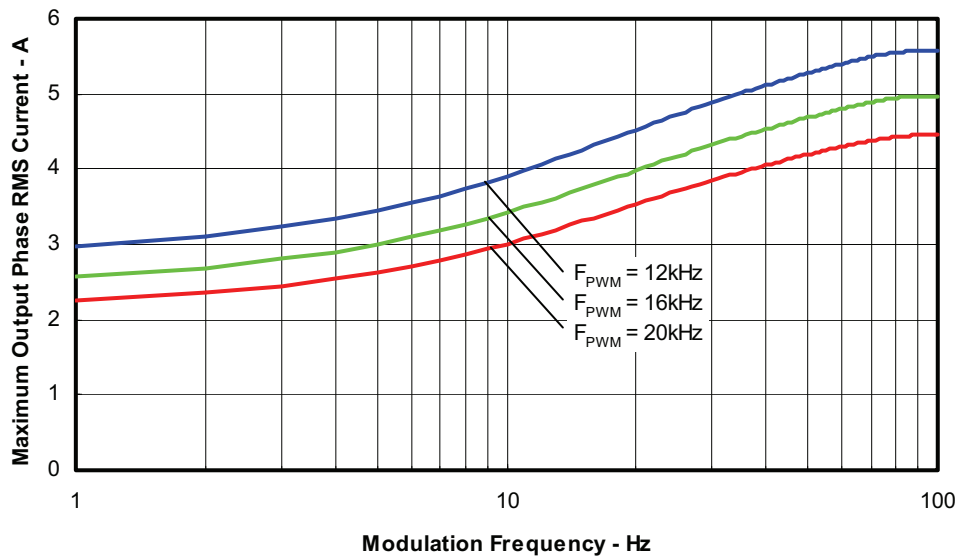

Figure 4. Maximum Sinusoidal Phase Current vs. Modulation Frequency Sinusoidal Modulation,  $V^+ = 400\text{V}$ ,  $T_j = 150^\circ\text{C}$ ,  $T_c = 100^\circ\text{C}$ ,  $MI = 0.8$ ,  $PF = 0.6$

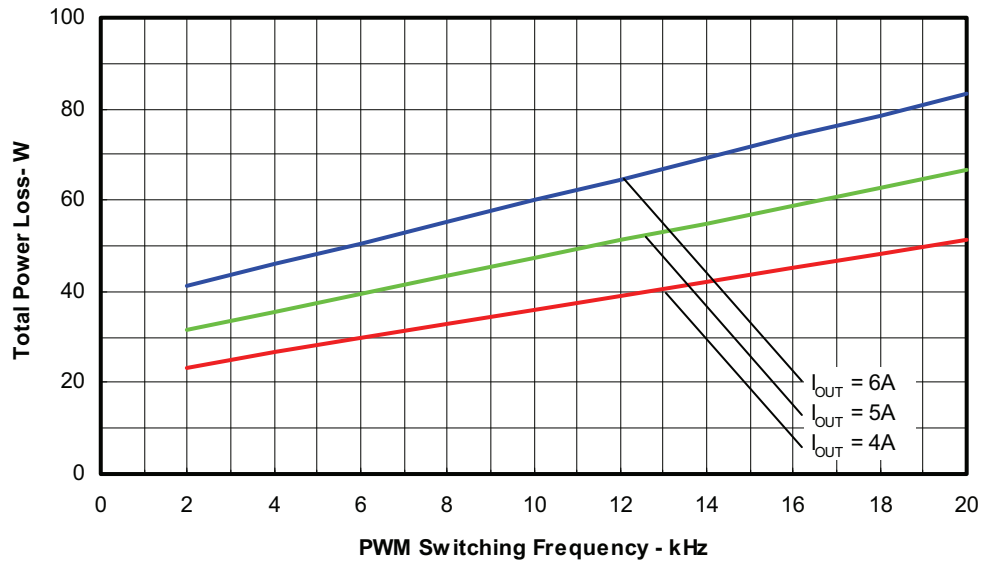

Figure 5. Total Power Losses vs. PWM Switching Frequency  
Sinusoidal Modulation,  $V^+ = 400V$ ,  $T_J = 150^\circ C$ ,  $MI = 0.8$ ,  $PF = 0.6$ ,  $f_{mod} = 100Hz$

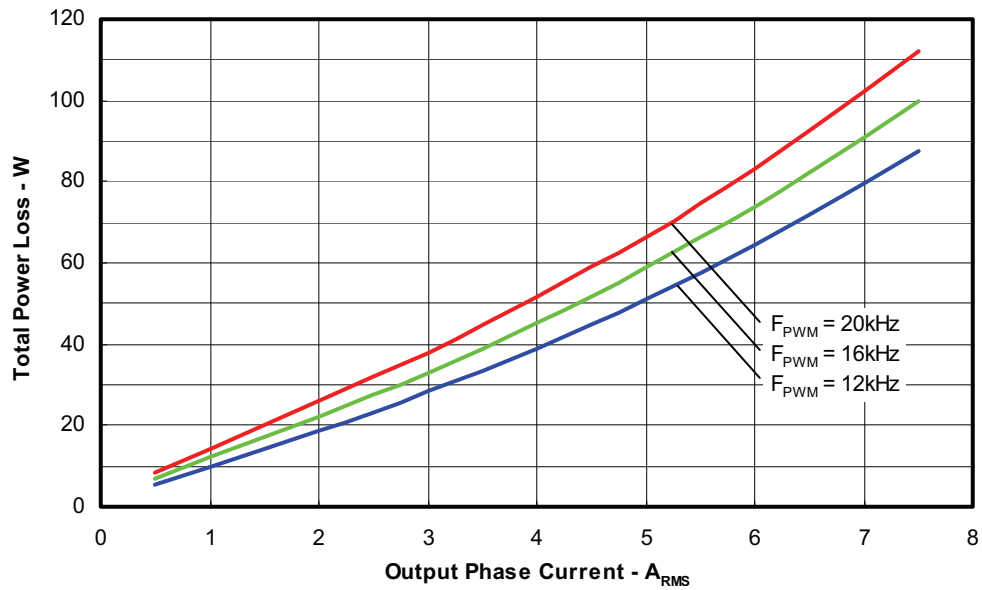

Figure 6. Total Power Losses vs. Output Phase Current  
Sinusoidal Modulation,  $V^+ = 400V$ ,  $T_J = 150^\circ C$ ,  $MI = 0.8$ ,  $PF = 0.6$ ,  $f_{mod} = 100Hz$

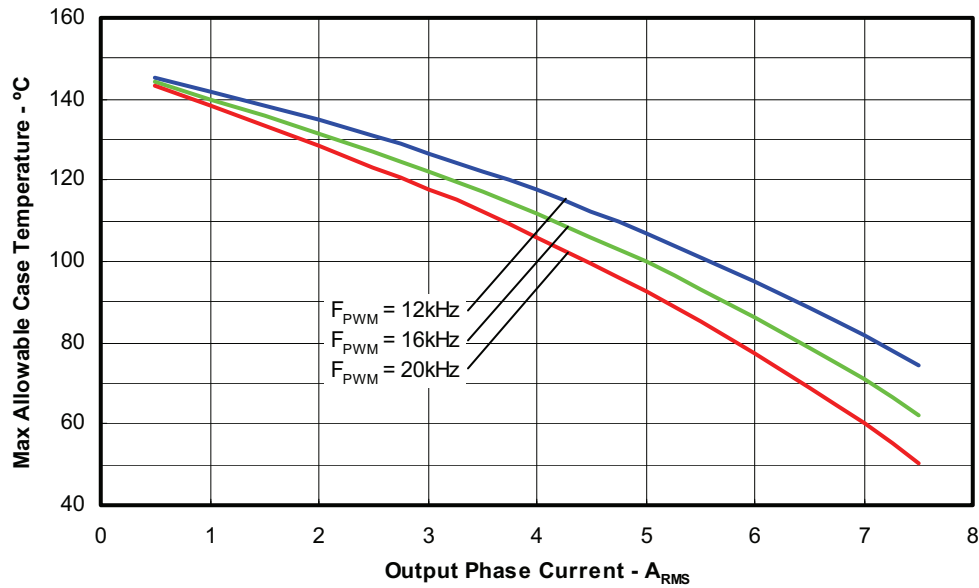

Figure 7. Maximum Allowable Case Temperature vs. Output RMS Current per Phase Sinusoidal Modulation,  $V^+=400V$ ,  $T_J=150^\circ C$ ,  $MI=0.8$ ,  $PF=0.6$ ,  $f_{mod}=50Hz$

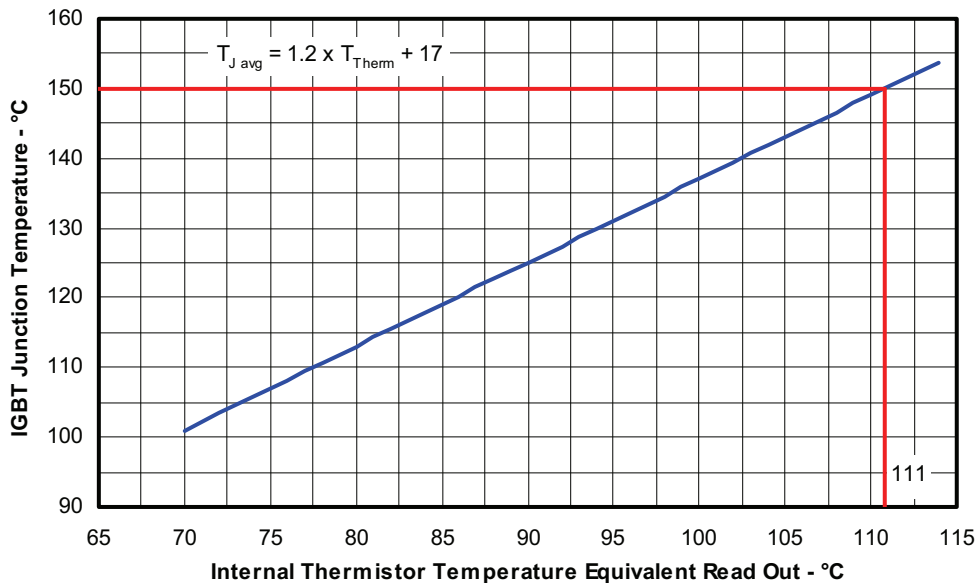

Figure 8. Estimated Maximum IGBT Junction Temperature vs. Thermistor Temperature Sinusoidal Modulation,  $V^+=400V$ ,  $I_{phase}=5A_{rms}$ ,  $f_{sw}=16kHz$ ,  $f_{mod}=50Hz$ ,  $MI=0.8$ ,  $PF=0.6$

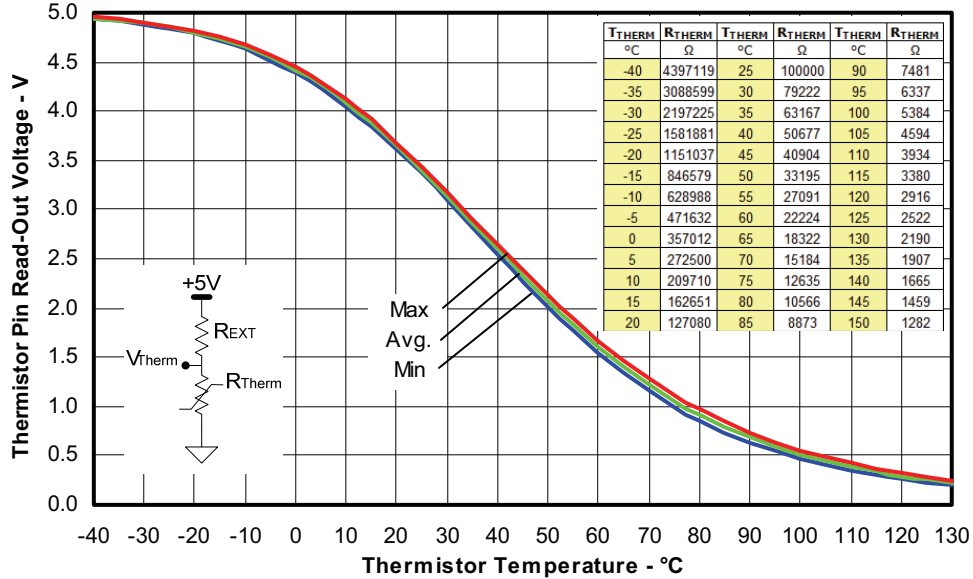

Figure 9. Thermistor Readout vs. Temperature (47kohm pull-up resistor, 5V) and Normal Thermistor Resistance values vs. Temperature Table.

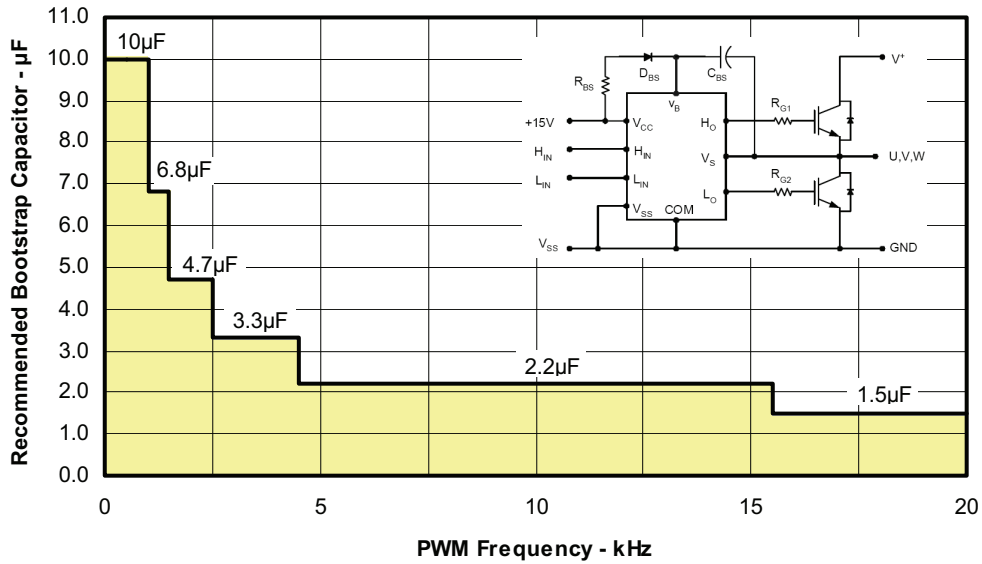

Figure 10. Recommended Bootstrap Capacitor Value vs. Switching Frequency

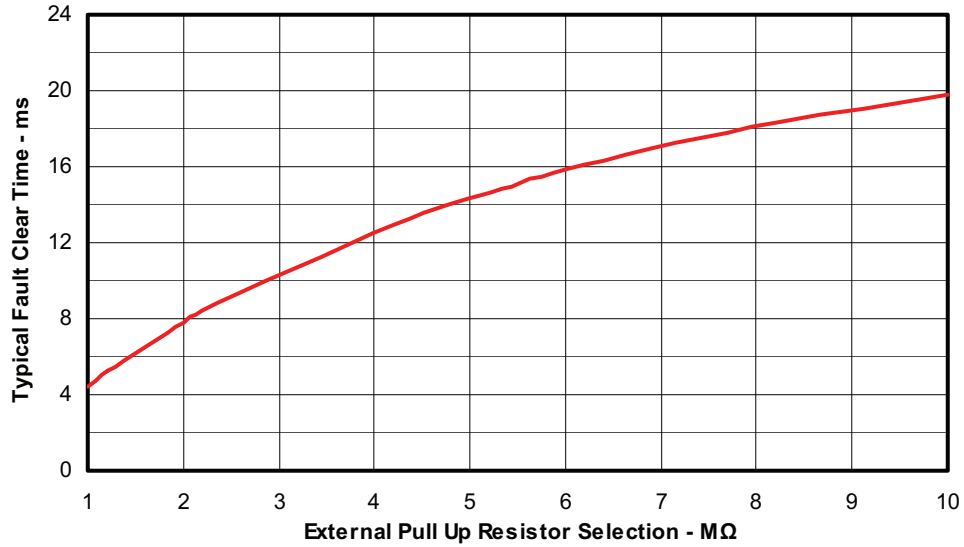

Figure 11a. External Pull Up resistor selection for Fault clear time  
(Recommended minimum Pull up Resistor is 1MΩ)

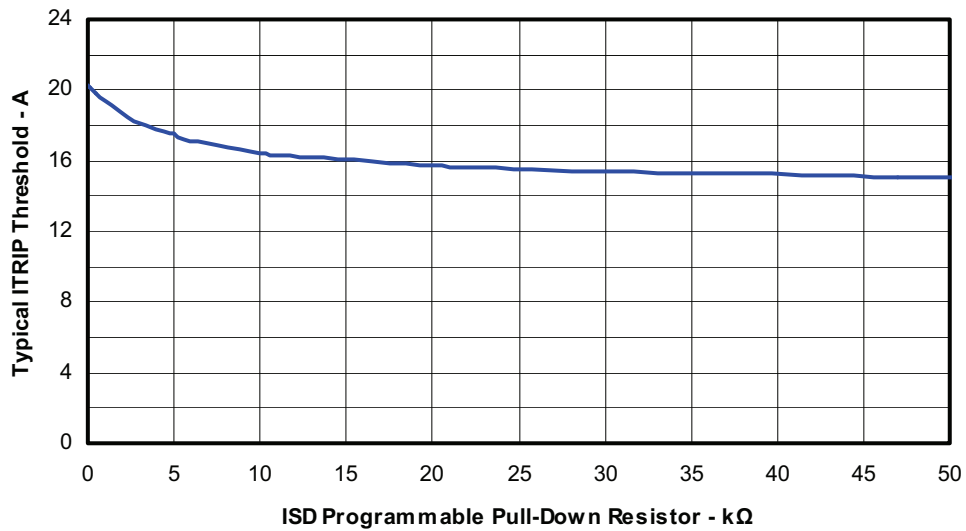

Figure 11b. Itrip Level External Pull down Resistor Selection

Figure 12. Switching Parameter Definitions

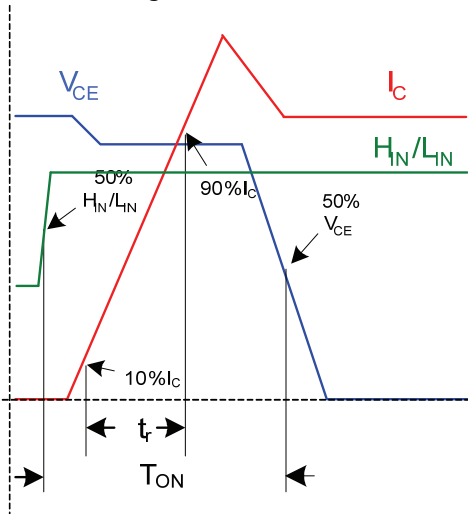

Figure 11a. Input to Output propagation turn-on delay time.

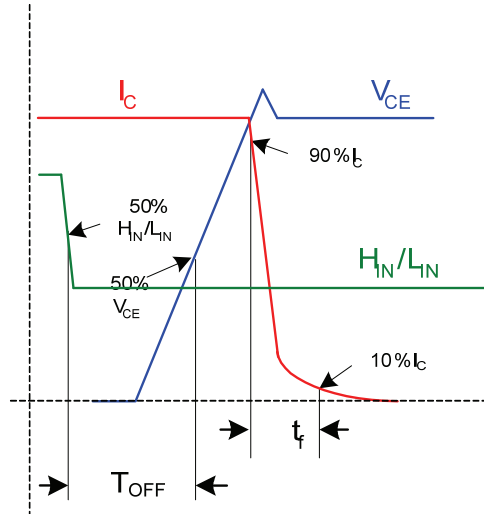

Figure 11b. Input to Output propagation turn-off delay time.

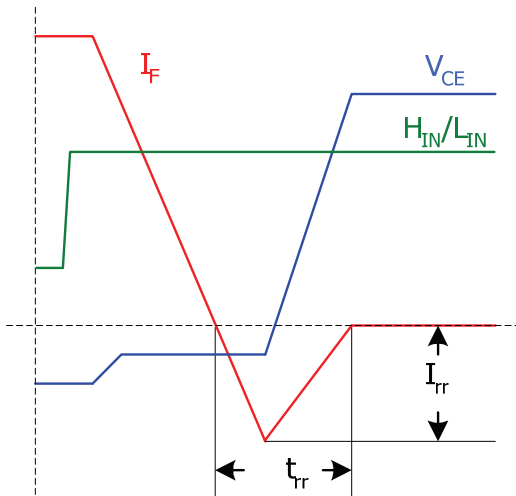

Figure 11c. Diode Reverse Recovery.

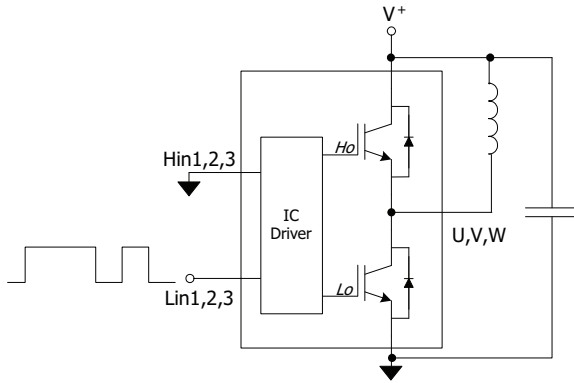

Figure CT1. Switching Loss Circuit

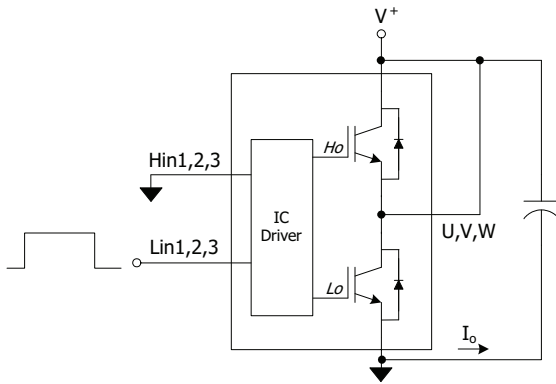
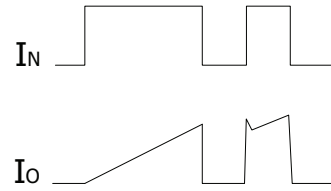

Figure CT2. S.C.SOA Circuit

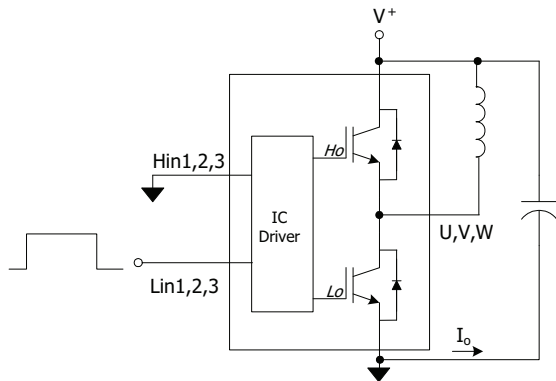
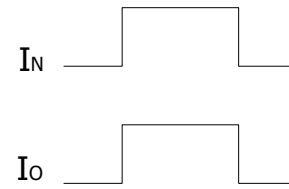
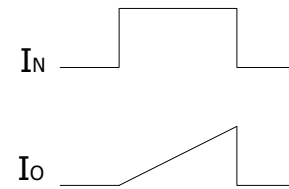
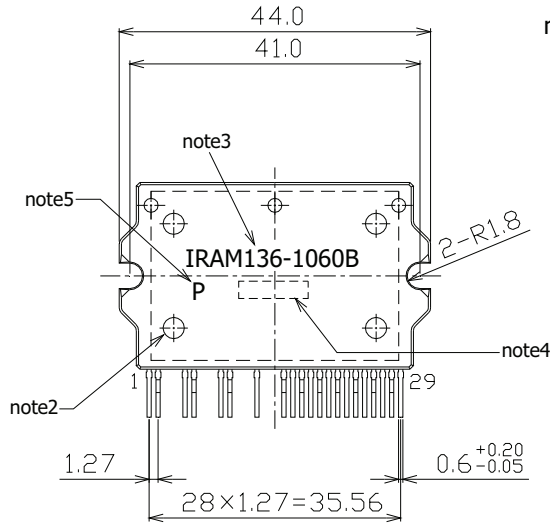

Figure CT3. R.B.SOA Circuit





## Package Outline IRAM136-1060B



missing pin : 3,4,7,8,11,12,14,15

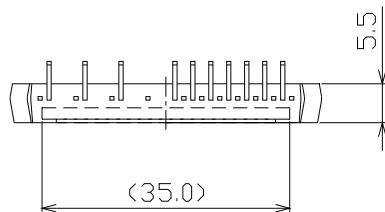
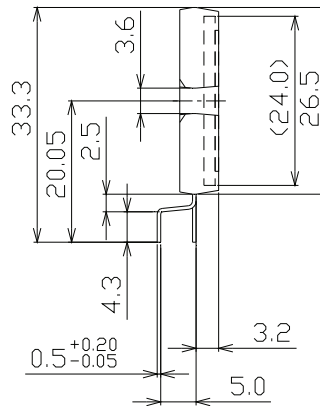

note1: Unit Tolerance is  $\pm 0.5$ mm,  
 Unless Otherwise Specified.

note2: Mirror Surface Mark indicates Pin1 Identification.

note3: Part Number Marking.  
 Characters Font in this drawing differs from  
 Font shown on Module.

note4: Lot Code Marking.  
 Characters Font in this drawing differs from  
 Font shown on Module.

note5: "P" Character denotes Lead Free.  
 Characters Font in this drawing differs from  
 Font shown on Module.

Dimensions in mm  
 For mounting instruction see AN-1049

# IRAM136-1060B

## Package Outline IRAM136-1060B2

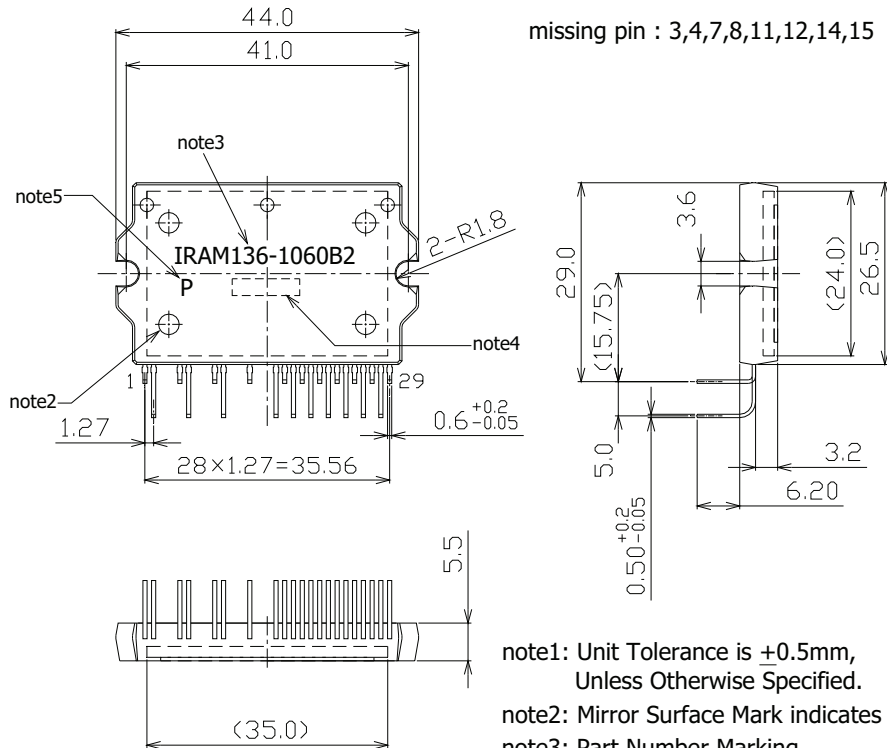

- note1: Unit Tolerance is  $\pm 0.5$ mm, Unless Otherwise Specified.
- note2: Mirror Surface Mark indicates Pin1 Identification.
- note3: Part Number Marking.  
Characters Font in this drawing differs from Font shown on Module.
- note4: Lot Code Marking.  
Characters Font in this drawing differs from Font shown on Module.
- note5: "P" Character denotes Lead Free.  
Characters Font in this drawing differs from Font shown on Module.

Dimensions in mm  
For mounting instruction see AN-1049