

CLD160

Large Active Area Silicon Planar photodiode

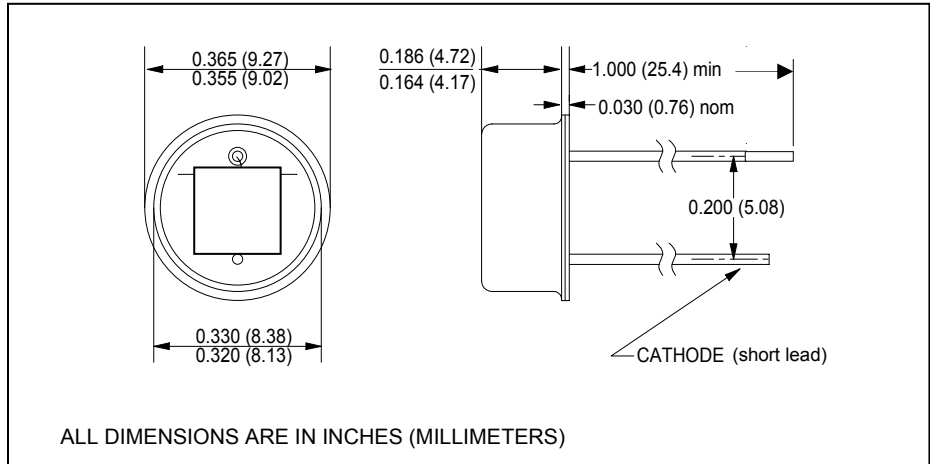

July, 2001

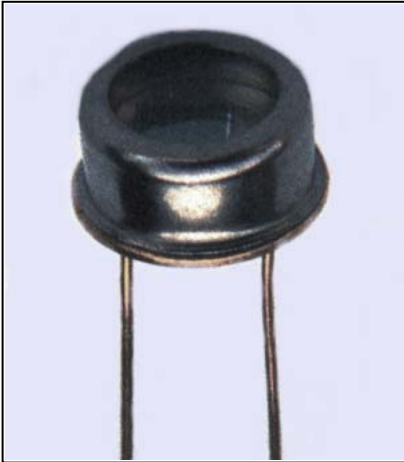

features

- 100° acceptance angle
- 860nm peak response
- hermetically sealed TO-5 package
- usable for visible through near-IR
- RoHS compliant

description

The CLD160 is a 0.122" x 0.122" active area silicon photodiode mounted in a flat window TO-5 package. Wide acceptance angle permits use in IR air communications ambient light detection, safety and monitoring, security systems, etc. For additional information, call Clairex.

absolute maximum ratings (T_A = 25°C unless otherwise stated)

storage temperature.....	-65°C to +150°C
operating temperature.....	-65°C to +150°C
lead soldering temperature ⁽¹⁾	260°C
reverse voltage.....	30V
continuous power dissipation ⁽²⁾	250mW

notes:

1. 0.06" (1.5mm) from the header for 5 seconds maximum.
2. Derate linearly 1.60mW/°C free air temperature to T_A = +150°C.

electrical characteristics (T _A = 25°C unless otherwise noted)						
symbol	parameter	min	typ	max	units	test conditions
I _{SC}	Short-circuit current ⁽³⁾	-	50	-	μA	V _{BIAS} = 0V, E _e = 5mW/cm ²
I _D	Dark current	-	-	5.0	nA	V _R = 15V, E _e = 0
V _O	Open circuit voltage ⁽³⁾	-	0.35	-	V	E _e = 5mW/cm ²
V _{BR}	Reverse breakdown	25	-	-	V	I _R = 100μA
C _J	Junction capacitance	-	-	200	pF	V _{BIAS} = 0V, f = 1MHz
t _r , t _f	Output rise and fall time ⁽⁴⁾	-	-	12	μs	R _L = 1kΩ
Θ _{HP}	Total angle at half sensitivity points	-	100	-	deg.	

- notes: 3. Radiation source is a frosted tungsten lamp with color temperature of 2854K or equivalent.
 4. Radiation source is an AlGaAs IRED operating at a peak emission wavelength of 880nm and E_e = 20mW/cm².

Clairex reserves the right to make changes at any time to improve design and to provide the best possible product.

Revised 3/15/06