

DESCRIPTION

M57174L-03 is a hybrid integrated circuit designed for driving n-channel IGBT modules that is able to connect its pins with PCB directly. This device provides the required electrical isolation between the input and output with each pulse transformers. This Hybrid IC can drive 3 IGBT elements by supply voltage of 2 lines (15V, 5V) and isolated type power supply is not necessary for each gate drivers.

It is possible to drive at high switching speed, because secondary block has an original comparator circuit with hysteresis and drive circuit.

Recommended IGBT modules:

$V_{CES} = 600V$ series up to 50A class

$V_{CES} = 1200V$ series up to 25A class

FEATURES

- Power supply for each gate driver is unnecessary (Adoption of pulse transformer method)
- TTL, CMOS logic compatible input interface
- Input-output isolation voltage..... 2500Vrms, for 1 min
- Each outputs isolation voltage.....2500Vrms, for 1 min
- Space is saved because of SIL structure and built-in 3 drivers.

APPLICATIONS

AC-DC motor controls, General purpose inverter, Servo controls, UPS, Switching power supply, etc.

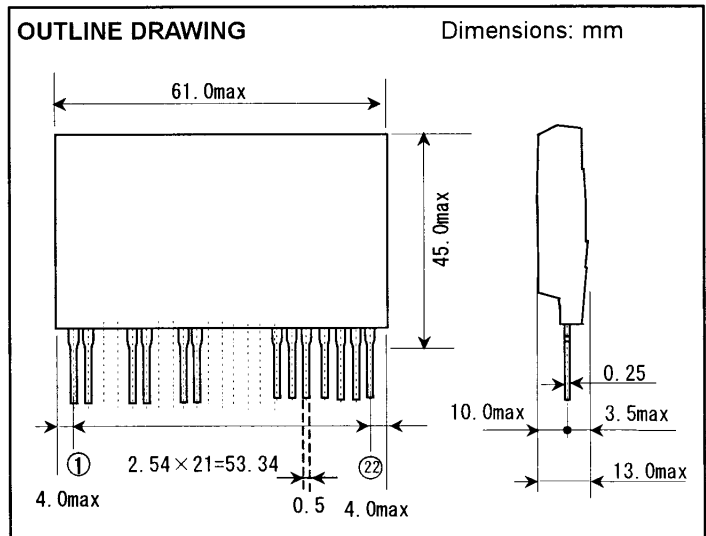

BLOCK DIAGRAM

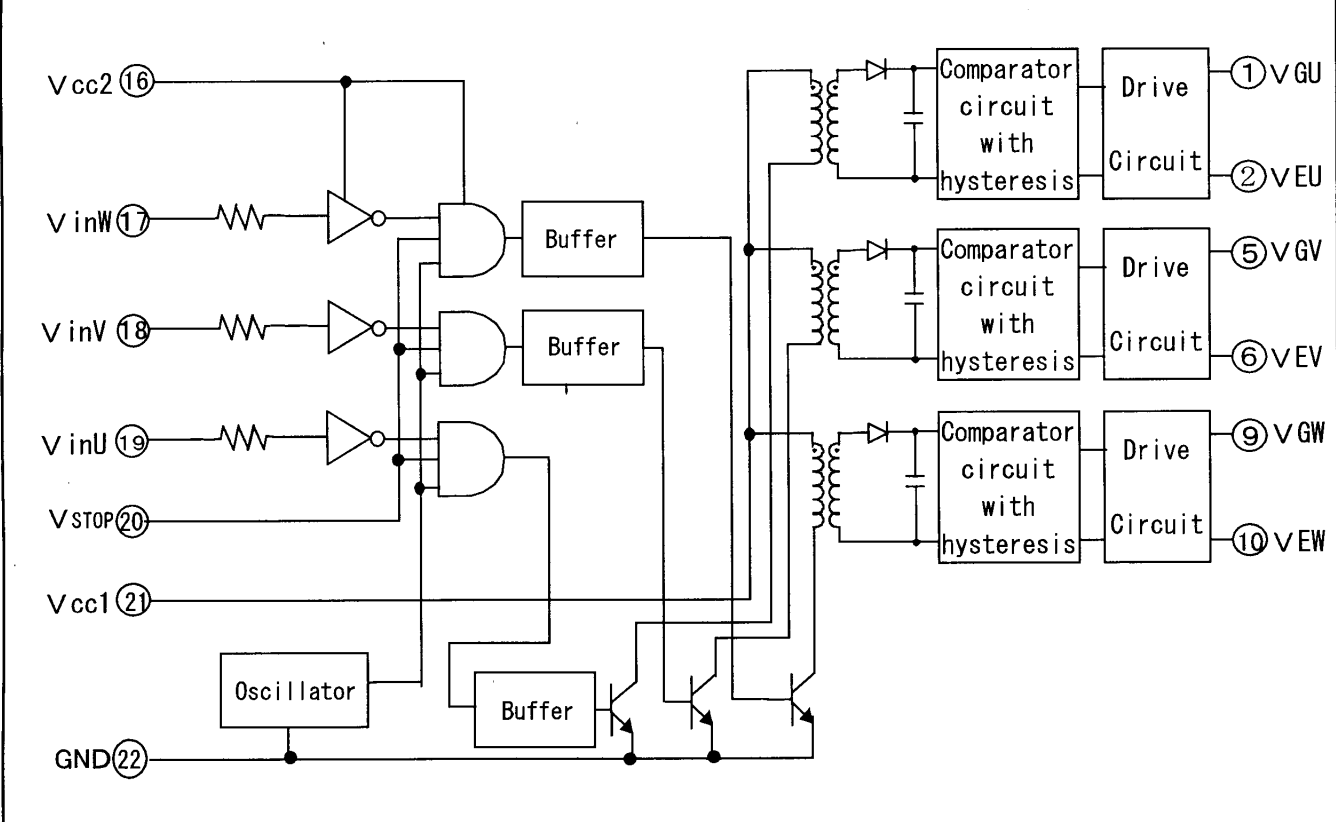

MAXIMUM RATINGS (unless otherwise noted, $T_a=25^\circ\text{C}$)

Symbol	Parameter	Conditions	Ratings	Unit
V_{CC1}	Supply voltage 1	DC, between pins 21 and 22	-0.3 ~ 16.5	V
V_{CC2}	Supply voltage 2	DC, between pins 16 and 22	-0.5 ~ 5.5	V
V_{in}, V_{stop}	Input/Error signal voltage	Between pins 17, 18, 19, 20 and 22	-0.5 ~ +6	V
V_o	Output voltage	Output voltage "H"	V_{cc}	V
I_{OHP}	"H" output current	Pulse width: $P_W < 2\mu\text{s}$, $f \leq 20\text{kHz}$	-0.6	A
I_{OLP}	"L" output current	Pulse width: $P_W < 2\mu\text{s}$, $f \leq 20\text{kHz}$	0.6	A
V_{iso1}	Isolation voltage1	Sine wave, 60Hz, 1min. R.H. < 50%	2500	Vrms
V_{iso2}	Isolation voltage2	Sine wave, 60Hz, 1min., R.H. < 50%	2500	Vrms
T_C	Case temperature	—————	85	$^\circ\text{C}$
T_{opr}	Operating temperature	No condensation allowable	-20 ~ +60	$^\circ\text{C}$
T_{stg}	Storage temperature	No condensation allowable	-25 ~ +100	$^\circ\text{C}$

ELECTRICAL CHARACTERISTICS(Unless otherwise noted, $T_a=25^\circ\text{C}$, $V_{CC1} = 15.0\text{V}$, $V_{CC2} = 5.0\text{V}$, $f = 20\text{kHz}$, D.F. = 50%, $R_G=13\Omega$, $C_L = 4700\text{pF}$)

Symbol	Parameter	Test conditions	Limits			Unit
			Min	Typ	Max	
V_{CC1}	Supply voltage 1	Recommended range	14.55	15.0	16.0	V
V_{CC2}	Supply voltage 2	Recommended range	4.75	5.0	5.25	V
f	Switching frequency	Recommended range	—	—	20	kHz
R_G	Gate resistor	Recommended range	13	—	—	Ω
$V_{in(ON)}$	"H" level input threshold voltage	V_{in}	—	—	0.64	V
$V_{in(OFF)}$	"L" level input threshold voltage	V_{in}	3.5	—	—	V
V_{OH}	"H" output voltage	V_{in} : "L" and V_{stop} : "H",	13.5	14.8	—	V
V_{OL}	"L" output voltage	V_{in} : "H" or V_{stop} : "L",	—	0.6	1.4	V
t_{PLH}	"L-H" propagation time (* 1)	V_{in} : "L" and V_{stop} : "H",	—	1.3	2.2(*2)	μs
t_r	"L-H" rise time	V_{in} : "L" and V_{stop} : "H"	—	0.2	0.6	μs
t_{PHL}	"H-L" propagation time (* 1)	V_{in} : "H" or V_{stop} : "L",	—	1.0	2.0(*2)	μs
t_f	"H-L" fall time	V_{in} : "H" or V_{stop} : "L"	—	0.4	0.8	μs

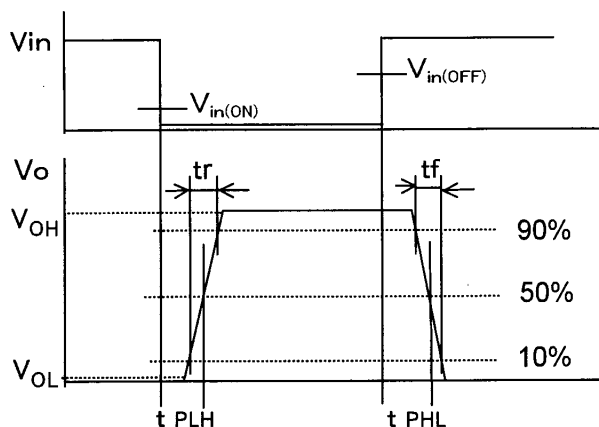
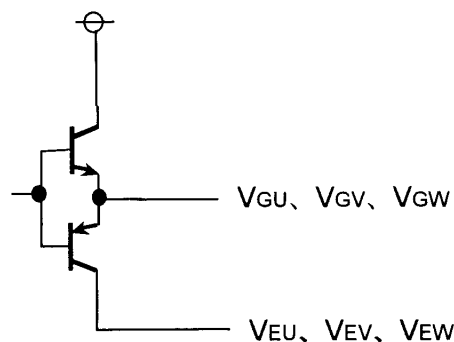
(*1) Depending on the timing of input signal and internal oscillation circuit, the propagation time changes in the extent of $\pm 0.4\mu\text{s}$.(*2) $t_{PLH}=2.2\mu\text{s}$ and $t_{PHL}=2.0\mu\text{s}$ at maximum limit: Those are contained the changing value $0.4\mu\text{s}$ by timing of (*1), so each center value is $t_{PLH}=1.8\mu\text{s}$ and $t_{PHL}=1.6\mu\text{s}$ at minimum limit.**DEFINITION OF CHARACTERISTICS****OUTPUT CIRCUIT**

APPLICATION CIRCUIT

Main Wiring

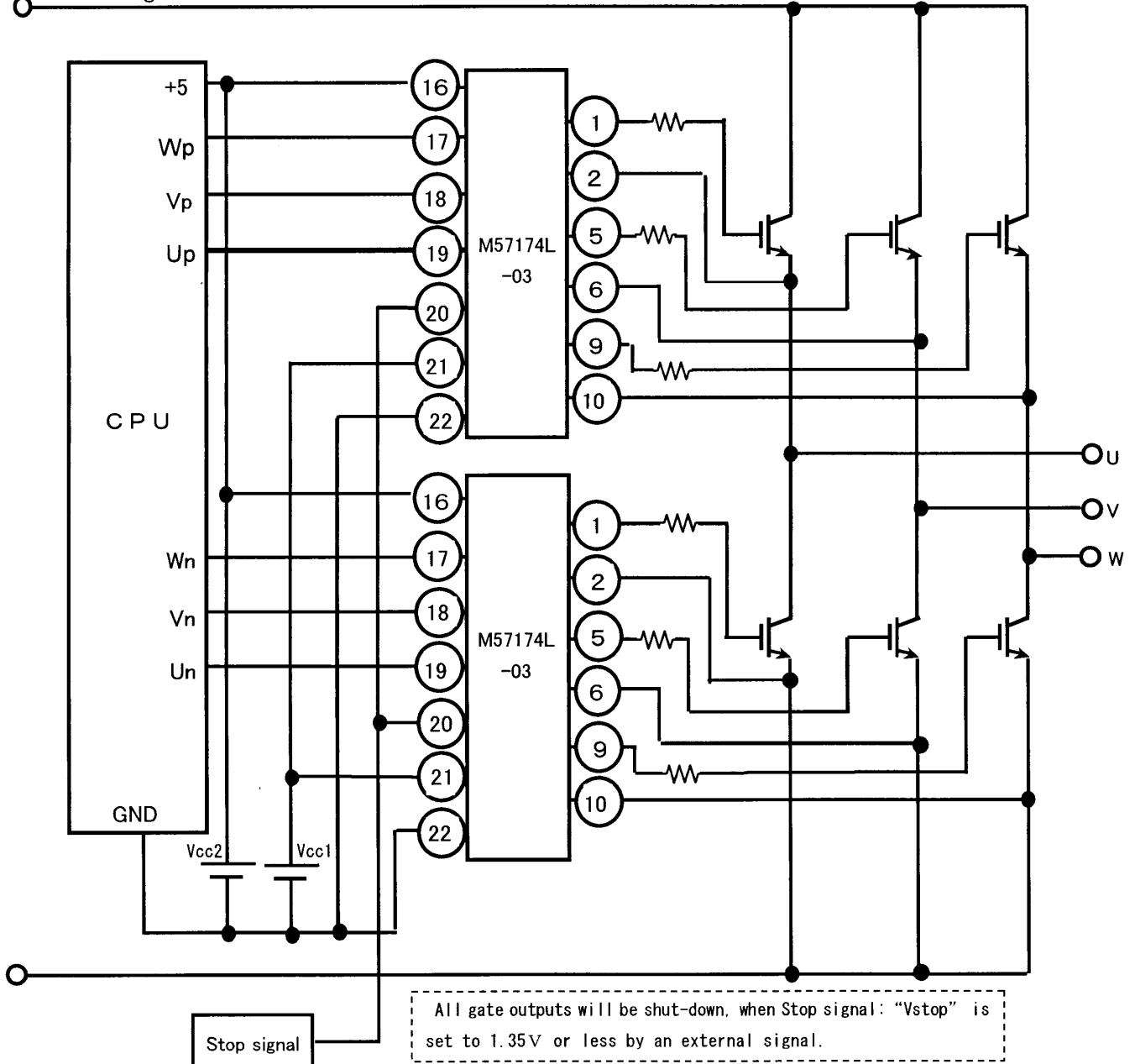

Reference

Please refer to the truth table of this device.

V _{stop}	V _{in}	V _o
L	—	L
H	L	H
H	H	L

PRECAUTION

In case that, wiring between an inverter output and a load motor is very long such as 10 m or more, this driver may output "H" voltage unexpectedly for about 1 μs by dv / dt noise when the other IGBT turned on, whose IGBT modules are constructed in same arm. If this problem occur, then two measures will be effective, that are shown as follows,

- (1) Connect capacitors of 0.01μF with terminals between gate and emitter on each IGBT module.
- (2) Setting up a dead time more then 5μs.

FOR SAFETY USING

Great detail and careful attention are given to the production activity of Hics, such as the development, the quality of production, and in its reliability. However the reliability of Hics depends not only on their own factors but also in their condition of usage. When handling Hics, please note the following cautions.

CAUTIONS	
Packing	<p>The materials used in packing Hics can only withstand normal external conditions.</p> <p>When exposed to outside shocks, rain and certain environmental contaminators, the packing materials will deteriorates. Please take care in handling.</p>
Carrying	<ol style="list-style-type: none"> 1) Don't stack boxes too high. Avoid placing heavy materials on boxes. 2) Boxes must be positioned correctly during transportation to avoid breakage. 3) Don't throw or drop boxes. 4) Keep boxes dry. Avoid rain or snow. 5) Minimal vibration and shock during transportation is desirable.
Storage	<p>When storing Hics, please observe the following notices or possible deterioration of their electrical characteristics, risk of solderability, and external damage may occur.</p> <ol style="list-style-type: none"> 1) Devices must be stored where fluctuation of temperature and humidity is minimal, and must not be exposed to direct sunlight. Store at the normal temperature of 5 to 30 degrees Celsius with humidity at 40 to 60%. 2) Avoid locations where corrosive gasses are generated or where much dust accumulates. 3) Storage cases must be static proof. 4) Avoid putting weight on boxes.
Extended storage	<p>When extended storage is necessary, Hics must be kept non-processed. When using Hics which have been stored for more than one year or under severe conditions, be sure to check that the exterior is free from flaw and other damages.</p>
Maximum ratings	<p>To prevent any electrical damages, use Hics within the maximum ratings. The temperature, current, voltage, etc. must not exceed these conditions.</p>
Polarity	<p>To protect Hics from destruction and deterioration due to wrong insertion, make sure of polarity in inserting leads into the board holes, conforming to the external view for the terminal arrangement.</p>

 **ISAHAYA ELECTRONICS CORPORATION**

Marketing division, Marketing planning department

6-41 Tsukuba, Isahaya, Nagasaki, 854-0065 Japan

Keep safety first in your circuit designs!

- ISAHAYA Electronics Corporation puts the maximum effort into making semiconductor products better and more reliable, but there is always the possibility that trouble may occur with them. Trouble with semiconductors may lead to personal injury, fire or property damage. Remember to give due consideration to safety when making your circuit designs, with appropriate measures such as (1) placement of substitutive, auxiliary, (2) use of non-frammable material or (3) prevention against any malfunction or mishap.

Notes regarding these materials

- These materials are intended as a reference to our customers in the selection of the ISAHAYA products best suited to the customer's application; they don't convey any license under any intellectual property rights, or any other rights, belonging ISAHAYA or third party.
- ISAHAYA Electronics Corporation assumes no responsibility for any damage, or infringement of any third party's rights, originating in the use of any product data, diagrams, charts or circuit application examples contained in these materials
- All information contained in these materials, including product data, diagrams and charts, represent information on products at the time of publication of these materials, and are subject to change by ISAHAYA Electronics Corporation without notice due to product improvements or other reasons. It is therefore recommended that customers contact ISAHAYA Electronics Corporation or an authorized ISAHAYA products distributor for the latest product information before purchasing product listed herein.
- ISAHAYA Electronics Corporation products are not designed or manufactured for use in a device or system that is used under circumstances in which human life is potentially at stake. Please contact ISAHAYA electronics corporation or an authorized ISAHAYA products distributor when considering the use of a product contained herein for any specific purposes, such as apparatus or systems for transportation, vehicular, medical, aerospace, nuclear, or undersea repeater use.
- The prior written approval of ISAHAYA Electronics Corporation is necessary to reprint or reproduce in whole or in part these materials.
- If these products or technologies are subject to the Japanese export control restrictions, they must be exported under a license from the Japanese government and cannot be imported into a country other than the approved destination. Any diversion or reexport contrary to the export control laws and regulations of Japan and/or the country of destination is prohibited.
- Please contact ISAHAYA Electronics Corporation or an authorized ISAHAYA products distributor for further details on these materials or the products contained therein.