

# 16-bit Proprietary Microcontroller

CMOS

## F<sup>2</sup>MC-16LX MB90820 Series

### MB90822/823/F822A/F823A/V820

#### ■ DESCRIPTION

The MB90820 series is a line of general-purpose, Fujitsu 16-bit microcontrollers designed for process control applications which require high-speed real-time processing, such as consumer products.

While inheriting the AT architecture of the F<sup>2</sup>MC\* family, the instruction set for the F<sup>2</sup>MC-16LX CPU core of the MB90820 series incorporates additional instructions for high-level languages, supports extended addressing modes, and contains enhanced multiplication and division instructions as well as a substantial collection of improved bit manipulation instructions. In addition, the MB90820 series has an on-chip 32-bit accumulator which enables processing of long-word data.

The peripheral resources integrated in the MB90820 series include : an 8/10-bit A/D converter, 8-bit D/A converters, UARTs (SCI) 0, 1, multi-functional timer (16-bit free-running timer, input capture units (ICUs) 0 to 3, output compare units (OCUs) 0 to 5, 16-bit PPG timer 0, waveform generator), 16-bit PPG timer 1, 2, PWC 0, 1, 16-bit reload timer 0, 1 and DTP/external interrupt.

\*: F<sup>2</sup>MC stands for FUJITSU Flexible Microcontroller, a registered trademark of FUJITSU LIMITED.

#### ■ FEATURES

- Minimum execution time of instruction : 42 ns / 4 MHz oscillation (uses PLL clock multiplication) maximum multiplier = 6
- Maximum memory space  
16M bytes  
Linear/bank access

(Continued)

#### ■ PACKAGES

80-pin plastic QFP

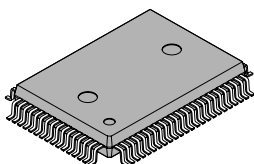

(FPT-80P-M06)

80-pin plastic LQFP

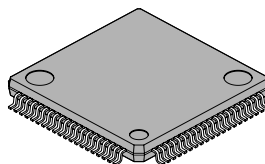

(FPT-80P-M05)

80-pin plastic LQFP

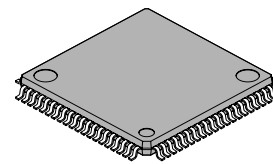

(FPT-80P-M11)

# MB90820 Series

(Continued)

- Instruction set optimized for controller applications
  - Supported data types : bit, byte, word, and long-word types
  - Standard addressing modes : 23 types
  - 32-bit accumulator enhancing high-precision operations
  - Enhanced multiplication/division and RETI instructions
- Enhanced high level language (C) and multi-tasking support instructions
  - Use of a system stack pointer
  - Symmetrical instruction set and barrel shift instructions
- Program patch function (for two address pointers)
- Increased execution speed : 4-byte instruction queue
- Powerful interrupt function
  - Up to eight priority levels programmable
  - External interrupt inputs : 8 channels
- Automatic data transmission function independent of CPU operation
  - Up to 16 channels for the extended intelligent I/O service
  - DTP request inputs : 8 channels
- Internal ROM
  - Flash memory : 64K/128K bytes with flash security
  - Mask ROM : 64K/128K bytes
- Internal RAM
  - EVA : 16K bytes
  - Flash memory : 4K bytes
  - Mask ROM : 4K bytes
- General-purpose ports
  - Up to 66 channels (pull-up resistor settable port for : 32 channels)
- A/D Converter (RC) : 16 channels
  - 8/10-bit resolution selectable
  - Conversion time : Min 3  $\mu$ s (24 MHz operation, including sampling time)
- 8-bit D/A Converter : 2 channels
- UART : 2 channels
- 16-bit PPG timer : 3 channels
  - Mode switching function provided (PWM mode or one-shot mode)
  - ch0 can be worked with multi-functional timer or independently
- 16-bit reload timer : 2 channels
- 16-bit PWC timer : 2 channels
- Multi-functional timer
  - Input capture : 4 channels
  - Output compare with selectable buffer : 6 channels
  - Free-running timer with up or up-down mode selection and selectable buffer: 1 channel
  - 16-bit PPG timer : 1 channel
  - Waveform generator : (16-bit timer : 3 channels, 3-phase waveform or dead time)
- Timebase counter/watchdog timer : 18-bit
- Low-power consumption mode :
  - Sleep mode
  - Stop mode
  - CPU intermittent operation mode

(Continued)

*(Continued)*

- Package :
  - LQFP-80 (FPT-80P-M05 : 0.50 mm pitch)
  - LQFP-80 (FPT-80P-M11 : 0.65 mm pitch)
  - QFP-80 (FPT-80P-M06 : 0.80 mm pitch)
- CMOS technology

# MB90820 Series

## ■ PRODUCT LINEUP

Part number Item	MB90V820	MB90F822A	MB90F823A	MB90822	MB90823
Classification	Evaluation product	Flash memory product with flash security		Mask ROM product	
ROM size	—	64K bytes	128K bytes	64K bytes	128K bytes
RAM size	16K bytes	4K bytes			
CPU function	Number of instruction : 351 Minimum execution time : 42 ns / 4 MHz (PLL × 6) Addressing mode : 23 Data bit length : 1, 8, 16 bits Maximum memory space: 16M bytes				
I/O port	I/O port (CMOS) : 66				
PWC	Pulse width counter timer : 2 channels Timer function (select the counter timer from three internal clocks) Various pulse width measuring function (“H” pulse width, “L” pulse width, rising edge to falling edge period, falling edge to rising edge period, rising edge to rising edge period and falling edge to falling edge period)				
UART	UART : 2 channels With full-duplex double buffer (8-bit length) Clock asynchronous or clock synchronized transmission (with start and stop bits) can be selected and used. Transmission can be one-to-one (bidirectional communication) or one-to-n (master-slave communication).				
16-bit reload timer	Reload timer : 2 channels Reload mode, single-shot mode or event count mode selectable				
16-bit PPG timer	PPG timer : 3 channels PWM mode or single-shot mode selectable Ch0 can be worked with multi-functional timer or independently.				
Multi-functional timer (for AC/DC motor control)	16-bit free-running timer with up or up-down mode selection and buffer : 1 channel 16-bit output compare : 6 channels 16-bit input capture : 4 channels 16-bit PPG timer : 1 channel Waveform generator (16-bit timer : 3 channels, 3-phase waveform or dead time)				
8/10-bit A/D converter	8/10-bit resolution (16 channels) Conversion time : Min 3 μs (24 MHz internal clock, including sampling time)				
8-bit D/A converter	8-bit resolution (2 channels)				
DTP/External interrupt	8 independent channels Interrupt factors : Rising edge, falling edge, “L” level or “H” level				
Low-power consumption	Stop mode / Sleep mode / CPU intermittent operation mode				

(Continued)

# MB90820 Series

(Continued)

Part number Item	MB90V820	MB90F822A	MB90F823A	MB90822	MB90823
Package	PGA-299	LQFP-80 (FPT-80P-M05 : 0.50 mm pitch) LQFP-80 (FPT-80P-M11 : 0.65 mm pitch) QFP-80 (FPT-80P-M06 : 0.80 mm pitch)			
Power supply voltage for operation*1	4.5 V to 5.5 V*1	3.5 V to 5.5 V : Normal operation when A/D converter and D/A converter are not used 4.0 V to 5.5 V : Normal operation when D/A converter is not used 4.5 V to 5.5 V : Normal operation when A/D converter and D/A converter are used			
Process	CMOS				
Emulator power supply*2	Included	—			

\*1 : MB90V820 is operating guaranteed temperature 0 °C to + 25 °C.

\*2 : It is setting of Jumper switch (TOOL VCC) when emulator (MB2147-01) is used.  
Please refer to the MB2147-01 or MB2147-20 hardware manual (3.3 Emulator-dedicated Power Supply switching) about details.

## ■ PACKAGE AND CORRESPONDING PRODUCTS

Package	MB90V820	MB90F822A	MB90F823A	MB90822	MB90823
PGA-299	○	X	X	X	X
FPT-80P-M05	X	○	○	○	○
FPT-80P-M11	X	○	○	○	○
FPT-80P-M06	X	○	○	○	○

○ : Available  
X : Not available

Note: For more information about each package, see "■ PACKAGE DIMENSIONS".

## ■ DIFFERENCES AMONG PRODUCTS

### Memory Size

In evaluation with an evaluation product, note the difference between the evaluation product and the product actually used. The following items must be taken into consideration.

- The MB90V820 does not have an internal ROM, however, operations equivalent to chips with an internal ROM can be evaluated by using a dedicated development tool, enabling selection of ROM size by settings of the development tool.
- In the MB90V820, images from FF8000<sub>H</sub> to FFFFFFF<sub>H</sub> are mapped to bank 00, and FE0000<sub>H</sub> to FF7FFF<sub>H</sub> are mapped to bank FE and bank FF only. (This setting can be changed by configuring the development tool.)
- In the MB90822/F822A, images from FF8000<sub>H</sub> to FFFFFFF<sub>H</sub> are mapped to bank 00, and FF0000<sub>H</sub> to FF7FFF<sub>H</sub> are mapped to bank FF only. In the MB90823/F823A, images from FF8000<sub>H</sub> to FFFFFFF<sub>H</sub> are mapped to bank 00, and FE0000<sub>H</sub> to FF7FFF<sub>H</sub> are mapped to bank FE and bank FF only.

## PIN ASSIGNMENT

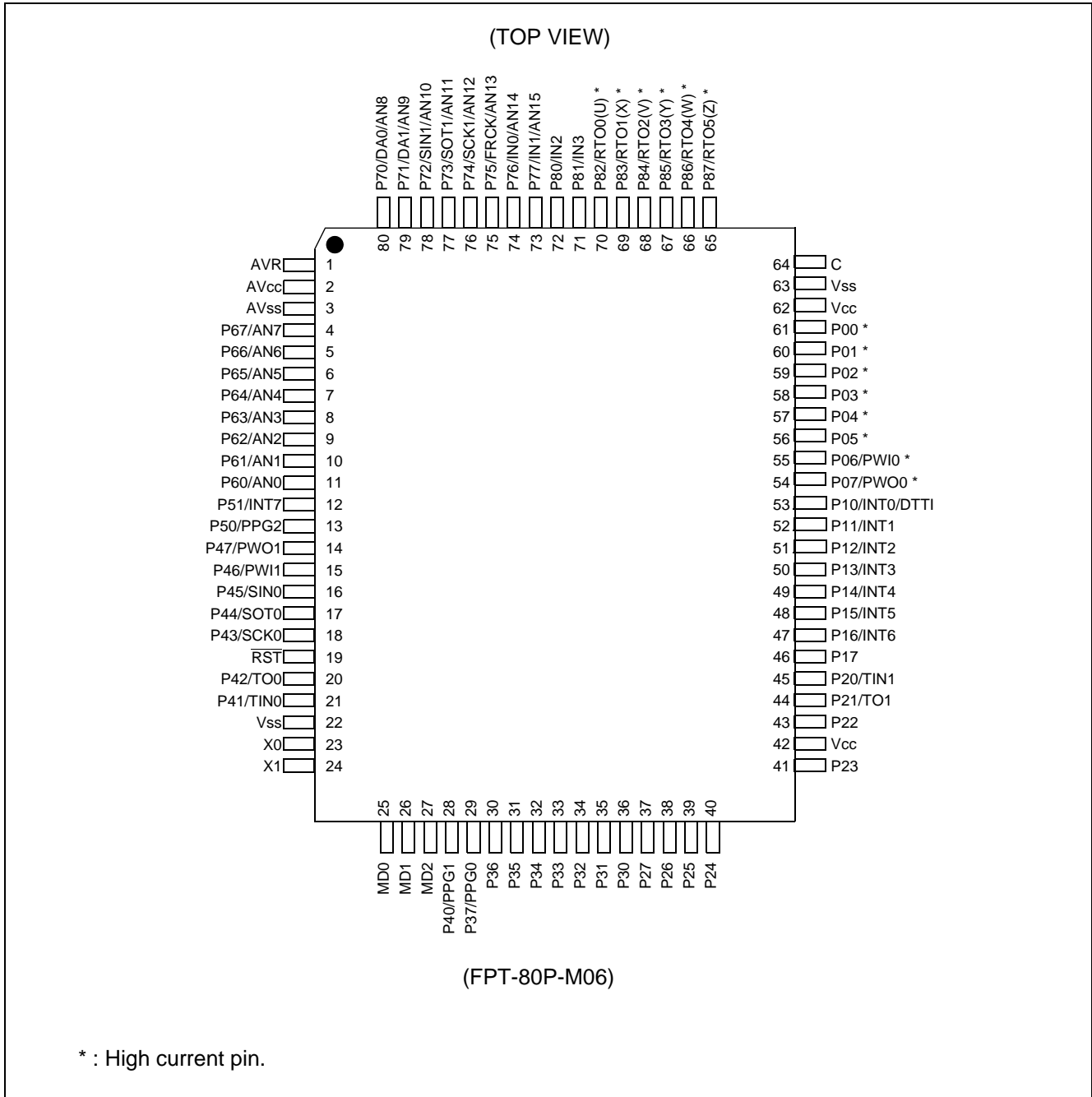

(Continued)

# MB90820 Series

(Continued)

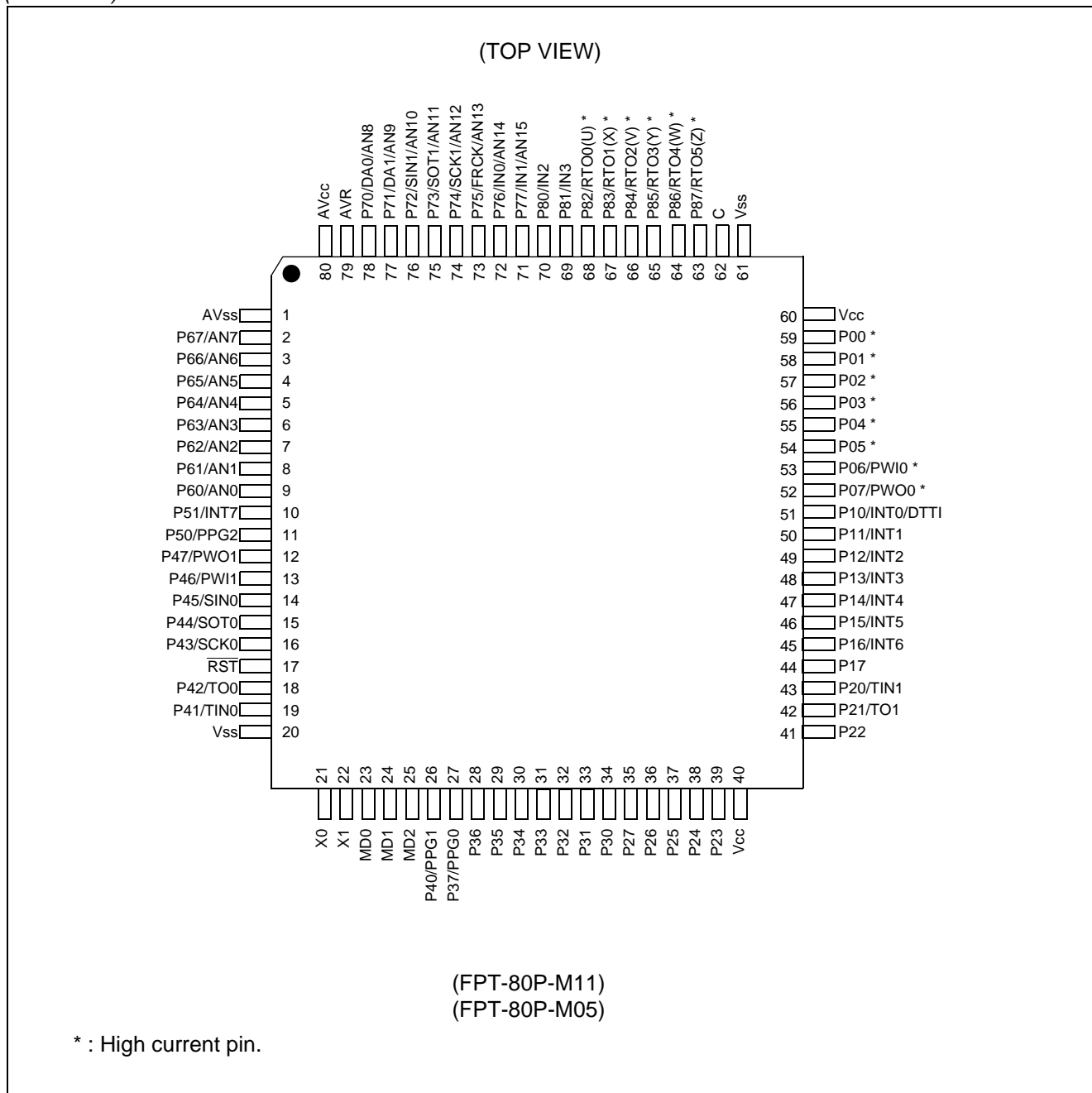



## ■ PIN DESCRIPTION

Pin no.		Pin name	I/O circuit *3	Pin status during reset	Function
LQFP *1	QFP *2				
21, 22	23, 24	X0,X1	A	Oscillating	Oscillation pins.
17	19	$\overline{\text{RST}}$	B	Reset input	External reset input pin.
59 to 54	61 to 56	P00 to P05	C	Port input	General-purpose I/O ports.
53	55	P06	C		General-purpose I/O ports.
		PW10			PWC ch0 signal input pin.
52	54	P07	C		General-purpose I/O ports.
		PW00			PWC ch0 signal output pin.
51	53	P10	D		General-purpose I/O ports.
		INT0			External interrupt request input ch0 pin.
		DTTI			RTO0 to RTO5 pins for fixed-level input. This function is enabled when the waveform generator specifies its input bits.
50 to 45	52 to 47	P11 to P16	D		General-purpose I/O ports.
		INT1 to INT6			External interrupt request input ch1 to ch6 pins.
44	46	P17	D		General-purpose I/O ports.
43	45	P20	D		General-purpose I/O ports.
		TIN1			External clock input pin for reload timer ch1.
42	44	P21	D		General-purpose I/O ports.
		TO1			Event output pin for reload timer ch1.
41, 39 to 35	43, 41 to 37	P22 to P27	D		General-purpose I/O ports.
34 to 28	36 to 30	P30 to P36	E		General-purpose I/O ports.
27	29	P37	E		General-purpose I/O ports.
		PPG0			Output pins for PPG timer ch0.
26	28	P40	F		General-purpose I/O ports.
		PPG1		Output pins for PPG timer ch1.	
19	21	P41	F	General-purpose I/O ports.	
		TIN0		External clock input pin for reload timer ch0.	
18	20	P42	F	General-purpose I/O ports.	
		TO0		Event output pin for reload timer ch0.	

\*1: FPT-80P-M05, FPT-80P-M11

\*2: FPT-80P-M06

\*3: See "■ I/O CIRCUIT TYPE".

(Continued)

# MB90820 Series

Pin no.		Pin name	I/O circuit *3	Pin status during reset	Function
LQFP *1	QFP *2				
16	18	P43	F	Port Input	General-purpose I/O ports.
		SCK0			Serial clock I/O pin for UART ch0.
15	17	P44	F		General-purpose I/O ports.
		SOT0			Serial data output pin for UART ch0.
14	16	P45	G		General-purpose I/O ports.
		SIN0			Serial data input pin for UART ch0.
13	15	P46	F		General-purpose I/O ports.
		PW11			PWC ch1 signal input pin.
12	14	P47	F		General-purpose I/O ports.
		PWO1			PWC ch1 signal output pin.
11	13	P50	F		General-purpose I/O ports.
		PPG2			Output pins for PPG timer ch2.
10	12	P51	F		General-purpose I/O ports.
		INT7			External interrupt request input ch7 pin.
9 to 2	11 to 4	P60 to P67	H	Analog input	General-purpose I/O ports.
		AN0 to AN7			A/D converter analog input pins.
78, 77	80, 79	P70, P71	I		General-purpose I/O ports.
		DA0, DA1			D/A converter analog output pins.
		AN8, AN9			A/D converter analog input pins.
76	78	P72	J		General-purpose I/O ports.
		SIN1			Serial data input pin for UART ch1.
		AN10			A/D converter analog input pins.
75	77	P73	K		General-purpose I/O ports.
		SOT1			Serial data output pin for UART ch1.
		AN11			A/D converter analog input pins.
74	76	P74	K		General-purpose I/O port.
		SCK1			Serial clock I/O pin for UART ch1.
		AN12			A/D converter analog input pins.
73	75	P75	K	General-purpose I/O ports.	
		FRCK		External clock input pin for free-running timer.	
		AN13		A/D converter analog input pins.	

\*1: FPT-80P-M05, FPT-80P-M11

\*2: FPT-80P-M06

\*3: See "■ I/O CIRCUIT TYPE".

(Continued)

# MB90820 Series

(Continued)

Pin no.		Pin name	I/O circuit *3	Pin status during reset	Function
LQFP *1	QFP *2				
72, 71	74, 73	P76, P77	K	Analog input	General-purpose I/O ports.
		IN0, IN1			Trigger input pins for input capture ch0, ch1.
		AN14, AN15			A/D converter analog input pins.
70, 69	72, 71	P80, P81	F	Port input	General-purpose I/O ports.
		IN2, IN3			Trigger input pins for input capture ch2, ch3.
68 to 63	70 to 65	P82 to P87	L	Port input	General-purpose I/O ports.
		RTO0 (U) to RTO5 (Z)			Waveform generator output pins. These pins output the waveforms specified at the waveform generator. Output is generated when waveform generator output is enabled.
25	27	MD2	M	Mode input	Input pin for operation mode specification.
24, 23	26, 25	MD1, MD0	N		Input pin for operation mode specification.
80	2	AV <sub>CC</sub>	–	–	Analog power supply pin.
79	1	AVR	–		Vref + pin for the A/D converter. Vref - is fixed to AV <sub>SS</sub> internally.
1	3	AV <sub>SS</sub>	–		Analog power supply (Ground) pin.
20, 61	22, 63	V <sub>SS</sub>	–	–	Power (Ground) pin.
40, 60	42, 62	V <sub>CC</sub>	–		Power pin.
62	64	C	–	–	Connect pin for smoothing capacitor to stabilize internal power supply.

\*1: FPT-80P-M05, FPT-80P-M11

\*2: FPT-80P-M06

\*3: See "■ I/O CIRCUIT TYPE".

# MB90820 Series

## I/O CIRCUIT TYPE

Classification	Type	Remarks
A		Main clock (main clock crystal oscillator) <ul style="list-style-type: none"> <li>Oscillation feedback resistor : approx. 1 M<math>\Omega</math></li> </ul>
B		<ul style="list-style-type: none"> <li>Hysteresis input</li> <li>Pull-up resistor : approx. 50 k<math>\Omega</math></li> </ul>
C		<ul style="list-style-type: none"> <li>CMOS output</li> <li>Hysteresis input</li> <li>Selectable pull-up resistor : approx. 50 k<math>\Omega</math></li> <li><math>I_{OL} = 12</math> mA</li> </ul>
D		<ul style="list-style-type: none"> <li>CMOS output</li> <li>Hysteresis input</li> <li>Selectable pull-up resistor : approx. 50 k<math>\Omega</math></li> <li><math>I_{OL} = 4</math> mA</li> </ul>
E		<ul style="list-style-type: none"> <li>CMOS output</li> <li>CMOS input</li> <li>With pull-up control</li> <li><math>I_{OL} = 4</math> mA</li> </ul>

(Continued)

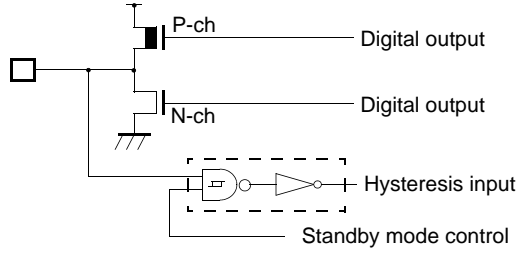
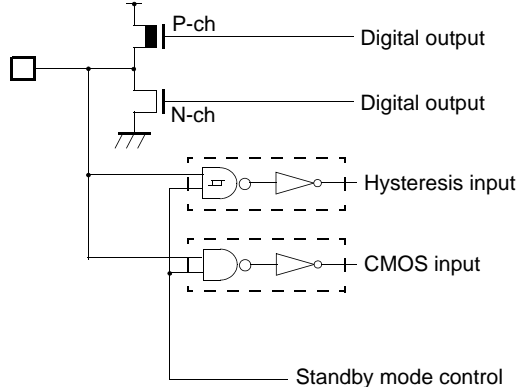
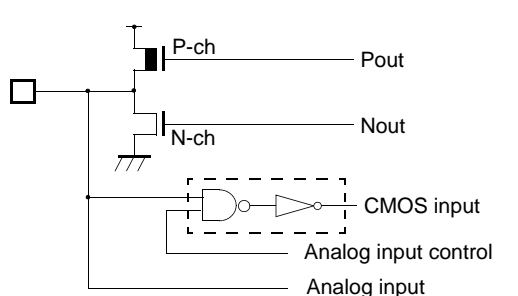
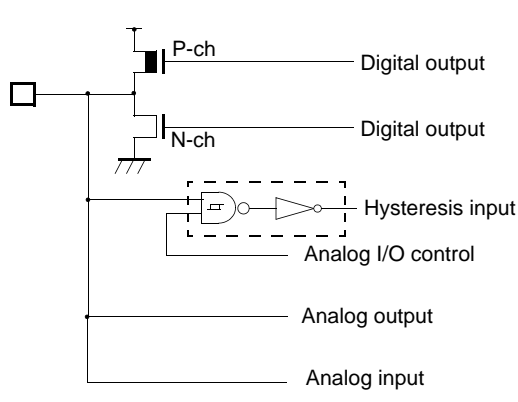
Classification	Type	Remarks
F	 <p>P-ch — Digital output N-ch — Digital output Hysteresis input Standby mode control</p>	<ul style="list-style-type: none"> <li>• CMOS output</li> <li>• Hysteresis input</li> <li>• <math>I_{OL} = 4 \text{ mA}</math></li> </ul>
G	 <p>P-ch — Digital output N-ch — Digital output Hysteresis input CMOS input Standby mode control</p>	<ul style="list-style-type: none"> <li>• CMOS output</li> <li>• Hysteresis input</li> <li>• CMOS input (selectable for UART ch0 data input pin)</li> <li>• <math>I_{OL} = 4 \text{ mA}</math></li> </ul>
H	 <p>P-ch — Pout N-ch — Nout CMOS input Analog input control Analog input</p>	<ul style="list-style-type: none"> <li>• CMOS output</li> <li>• CMOS input</li> <li>• Analog input</li> <li>• <math>I_{OL} = 4 \text{ mA}</math></li> </ul>
I	 <p>P-ch — Digital output N-ch — Digital output Hysteresis input Analog I/O control Analog output Analog input</p>	<ul style="list-style-type: none"> <li>• CMOS output</li> <li>• Hysteresis input</li> <li>• Analog output</li> <li>• Analog input</li> <li>• <math>I_{OL} = 4 \text{ mA}</math></li> </ul>

(Continued)

# MB90820 Series

(Continued)

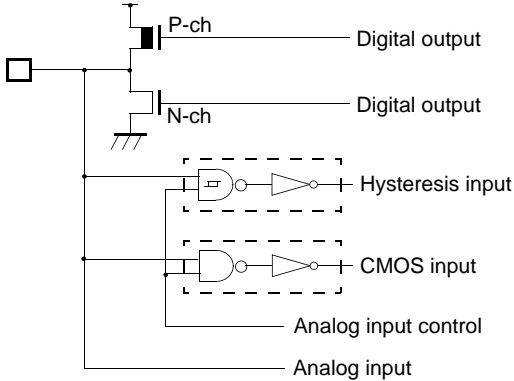
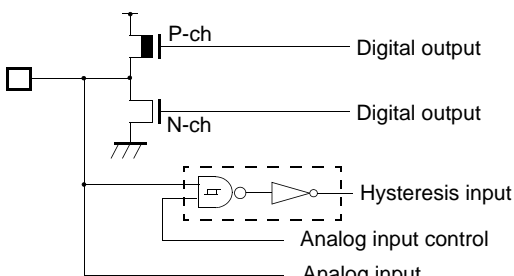
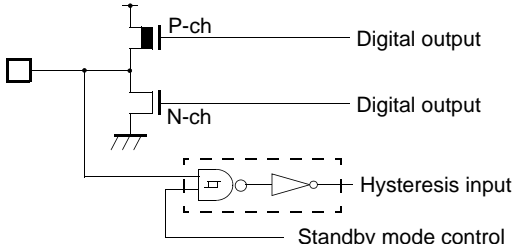
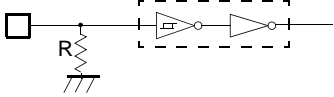
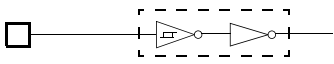
Classification	Type	Remarks
J	 <p>P-ch — Digital output N-ch — Digital output Hysteresis input CMOS input Analog input control Analog input</p>	<ul style="list-style-type: none"> <li>• CMOS output</li> <li>• Hysteresis input</li> <li>• CMOS input (selectable for UART ch1 data input pin)</li> <li>• <math>I_{OL} = 4 \text{ mA}</math></li> </ul>
K	 <p>P-ch — Digital output N-ch — Digital output Hysteresis input Analog input control Analog input</p>	<ul style="list-style-type: none"> <li>• CMOS output</li> <li>• Hysteresis input</li> <li>• Analog input</li> <li>• <math>I_{OL} = 4 \text{ mA}</math></li> </ul>
L	 <p>P-ch — Digital output N-ch — Digital output Hysteresis input Standby mode control</p>	<ul style="list-style-type: none"> <li>• CMOS output</li> <li>• Hysteresis input</li> <li>• <math>I_{OL} = 12 \text{ mA}</math></li> </ul>
M	 <p>R Hysteresis input</p>	<p>Mask ROM / evaluation product</p> <ul style="list-style-type: none"> <li>• Hysteresis input</li> <li>• Pull-down resistor : approx. <math>50 \text{ k}\Omega</math></li> </ul> <p>Flash memory product</p> <ul style="list-style-type: none"> <li>• CMOS input</li> <li>• No pull-down resistor</li> </ul>
N	 <p>Hysteresis input</p>	<p>Mask ROM / evaluation product</p> <ul style="list-style-type: none"> <li>• Hysteresis input</li> </ul> <p>Flash memory product</p> <ul style="list-style-type: none"> <li>• CMOS input</li> </ul>

## ■ HANDLING DEVICES

Special care is required for the following when handling the device :

- Preventing latch-up
- Stabilization of supply voltage
- Treatment of unused pins
- Using external clock
- Power supply pins ( $V_{CC}$  /  $V_{SS}$  )
- Pull-up/pull-down resistors
- Crystal Oscillator Circuit
- Turning-on Sequence of Power Supply to A/D Converter and D/A Converter, and Analog Inputs
- Connection of Unused Pins of A/D Converter and D/A Converter if A/D Converter and D/A Converter are unused
- Notes on energization
- Notes on During Operation of PLL Clock Mode

### 1. Preventing latch-up

CMOS IC chips may suffer latch-up under the following conditions :

- A voltage higher than  $V_{CC}$  or lower than  $V_{SS}$  is applied to an input or output pin.
- A voltage higher than the rated voltage is applied between  $V_{CC}$  and  $V_{SS}$ .
- The  $AV_{CC}$  power supply is applied before the  $V_{CC}$  voltage.

Latch-up may increase the power supply current drastically, causing thermal damage to the device.

In using the devices, take sufficient care to avoid exceeding maximum ratings.

For the same reason, also be careful not to let the analog power-supply voltage ( $AV_{CC}$ ,  $AVR$ ) exceed the digital power-supply voltage.

### 2. Stabilization of supply voltage

A sudden change in the supply voltage may cause the device to malfunction even within the specified  $V_{CC}$  supply voltage operation range. Therefore, the  $V_{CC}$  supply voltage should be stabilized.

For reference, the supply voltage should be controlled so that  $V_{CC}$  ripple variations (peak-to-peak values) at commercial frequencies (50 Hz to 60 Hz) fall below 10% of the standard  $V_{CC}$  supply voltage and the coefficient of fluctuation does not exceed 0.1 V/ms at instantaneous power switching.

### 3. Treatment of unused pins

Leaving unused input pins open may result in misbehavior or latch up and possible permanent damage of the device. Therefore they must be pulled up or pulled down through resistors. In this case those resistors should be more than 2 k $\Omega$ .

Unused bidirectional pins should be set to the output state and can be left open, or the input state with the above described connection.

### 4. Using external clock

To use external clock, drive the X0 pin and leave X1 pin open.

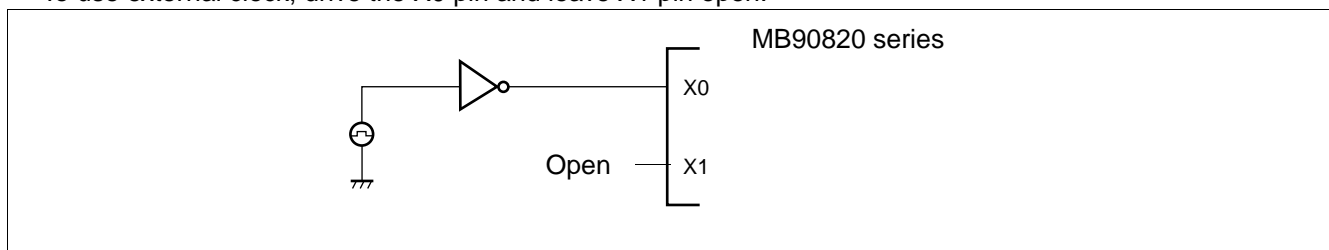

# MB90820 Series

## 5. Power supply pins ( $V_{CC}/V_{SS}$ )

- If there are multiple  $V_{CC}$  and  $V_{SS}$  pins, from the point of view of device design, pins to be of the same potential are connected the inside of the device to prevent such malfunctioning as latch up. To reduce unnecessary radiation, prevent malfunctioning of the strobe signal due to the rise of ground level, and observe the standard for total output current, be sure to connect the  $V_{CC}$  and  $V_{SS}$  pins to the power supply and ground externally.
- Connect  $V_{CC}$  and  $V_{SS}$  to the device from the current supply source at a low impedance.
- As a measure against power supply noise, connect a capacitor of about 0.1  $\mu\text{F}$  as a bypass capacitor between  $V_{CC}$  and  $V_{SS}$  in the vicinity of  $V_{CC}$  and  $V_{SS}$  pins of the device.

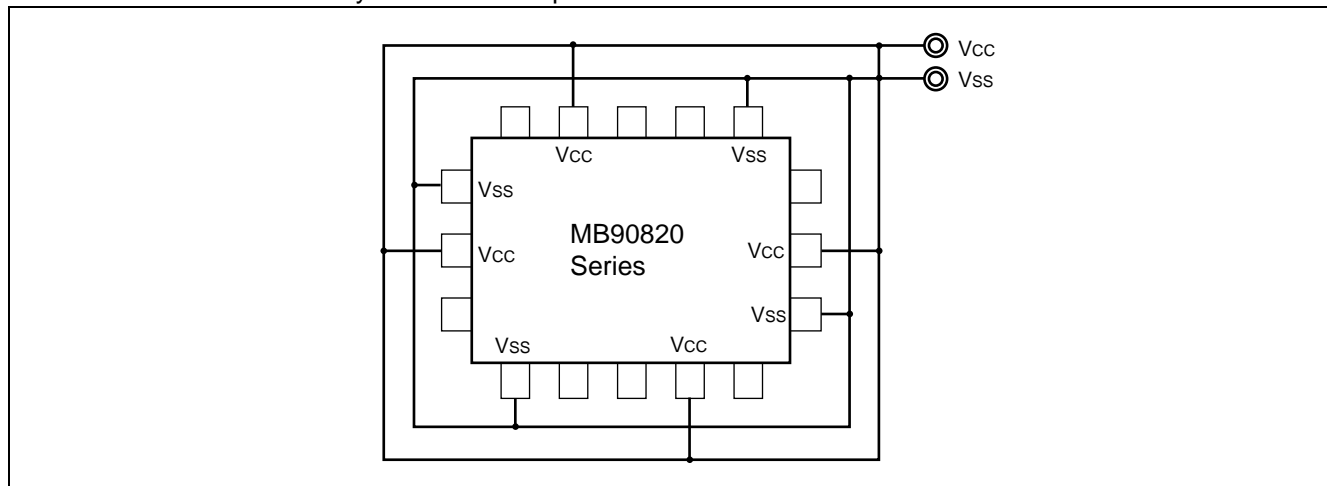

## 6. Pull-up/pull-down resistors

The MB90820 series does not support internal pull-up/pull-down resistors option (Port 0 to Port 3 : built-in pull-up resistors) . Use external components where needed.

## 7. Crystal oscillator circuit

Noises around X0 or X1 pins may be possible causes of abnormal operations. Make sure to provide bypass capacitors via shortest distance from X0, X1 pins, crystal oscillator (or ceramic oscillator) and ground lines, and make sure, to the utmost effort, that lines of oscillation circuit do not cross the lines of other circuits while you design a printed circuit board.

It is highly recommended to provide a printed circuit board art work surrounding X0 and X1 pins with a ground area for stabilizing the operation.

## 8. Turning-on sequence of power supply to A/D converter and D/A converter, and analog inputs

Make sure to turn on the A/D converter power supply, D/A converter power supply ( $AV_{CC}$ ,  $AV_{RH}$ ,  $AV_{RL}$ ) and analog inputs ( $AN_0$  to  $AN_{15}$ ) after turning-on the digital power supply ( $V_{CC}$ ).

Turn-off the digital power after turning off the A/D converter power supply, D/A converter power supply, and analog inputs. In this case, make sure that the voltage not exceed  $AV_{RL}$  or  $AV_{CC}$  (turning on/off the analog and digital power supplies simultaneously is acceptable).

## 9. Connection of unused pins of A/D converter and D/A converter if A/D converter and D/A converter are unused

Connect unused pins of A/D converter and D/A converter to  $AV_{CC} = V_{CC}$ ,  $AV_{SS} = AV_{RH} = AV_{RL} = V_{SS}$ .

## 10. Notes on energization

To prevent the internal regulator circuit from malfunctioning, set the voltage rise time during energization at 50  $\mu\text{s}$  or more (0.2 V to 2.7 V) .



## 11. Notes on During Operation of PLL Clock Mode

If the PLL clock mode is selected, the microcontroller attempts to be working with the self-oscillating circuit even when there is no external oscillator or external clock input is stopped. Performance of this operation, however, cannot be guaranteed.

# MB90820 Series

## ■ BLOCK DIAGRAM

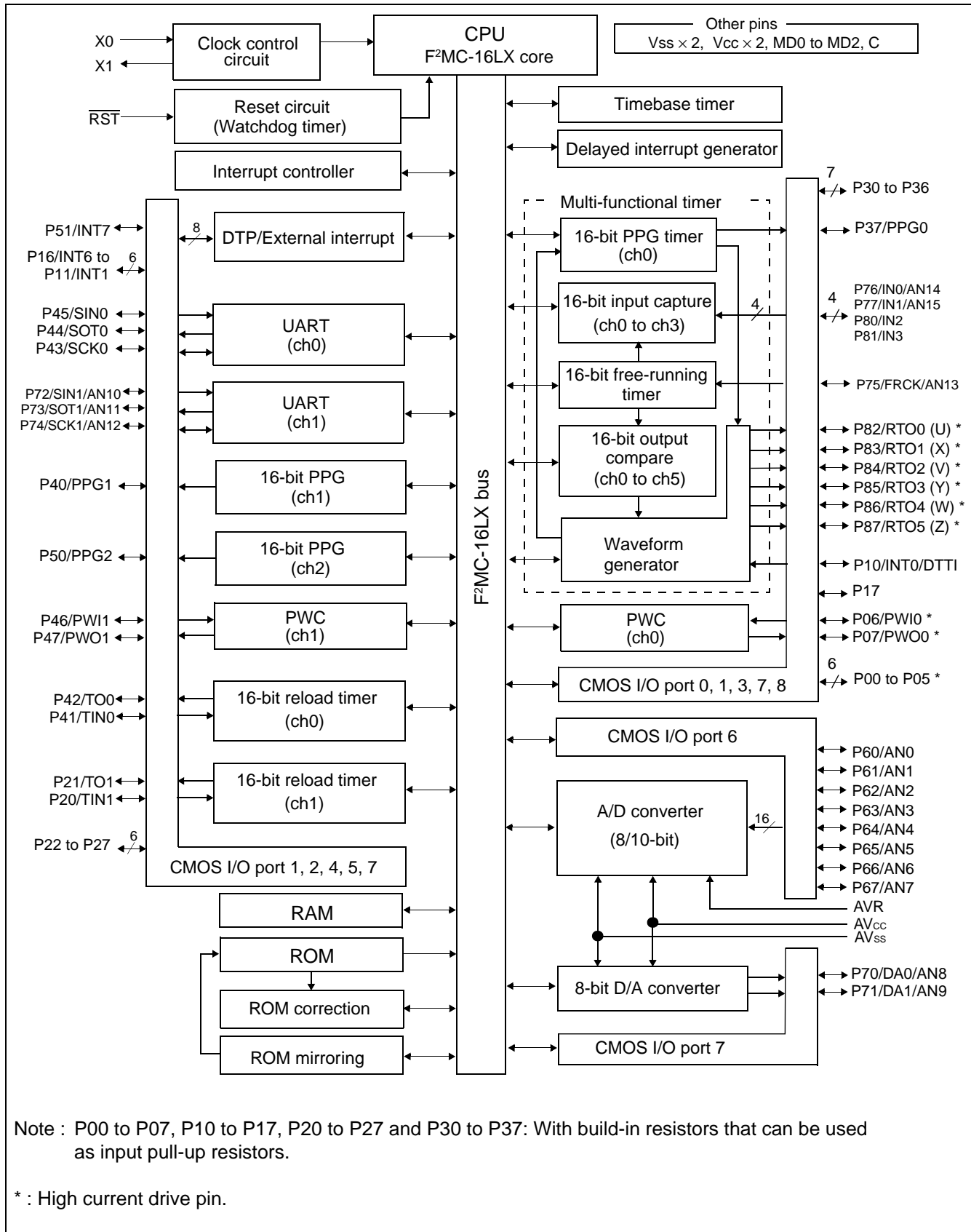

## ■ MEMORY MAP

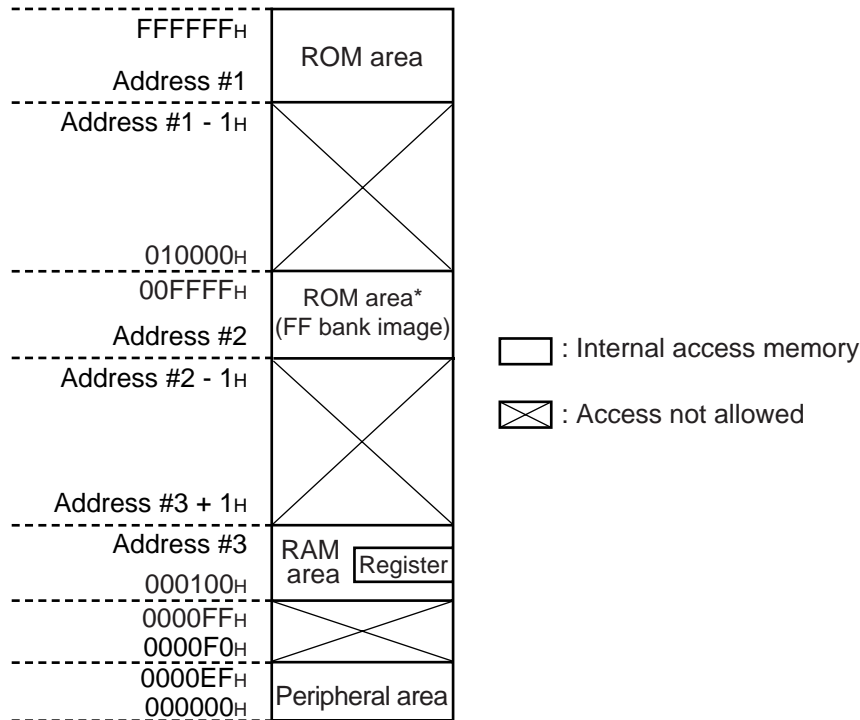

\* : In Single chip mode, the mirror function is supported.

Parts no.	Address#1	Address#2	Address#3
MB90822	FF0000 <sub>H</sub>	008000 <sub>H</sub>	0010FF <sub>H</sub>
MB90823	FE0000 <sub>H</sub>	008000 <sub>H</sub>	0010FF <sub>H</sub>
MB90F822A	FF0000 <sub>H</sub>	008000 <sub>H</sub>	0010FF <sub>H</sub>
MB90F823A	FE0000 <sub>H</sub>	008000 <sub>H</sub>	0010FF <sub>H</sub>
MB90V820	(FE0000 <sub>H</sub> )	008000 <sub>H</sub>	0040FF <sub>H</sub>

Note: The ROM data of bank FF is reflected to the upper address of bank 00, realizing effective use of the C compiler small model. The lower 16-bit is assigned to the same address, enabling reference of the table on the ROM without stating "far". For example, if an attempt has been made to access 00C000<sub>H</sub>, the contents of the ROM at FFC000<sub>H</sub> are accessed actually. Since the ROM area of the FF bank exceeds 32K bytes, the whole area cannot be reflected in the image for the 00 bank. The ROM data at FF8000<sub>H</sub> to FFFFFFF<sub>H</sub> looks, therefore, as if it were the image for 008000<sub>H</sub> to 00FFFF<sub>H</sub>. Thus, it is recommended that the ROM data table be stored in the area of FF8000<sub>H</sub> to FFFFFFF<sub>H</sub>.

# MB90820 Series

## ■ F<sup>2</sup>MC-16LX CPU PROGRAMMING MODEL

- Dedicated registers

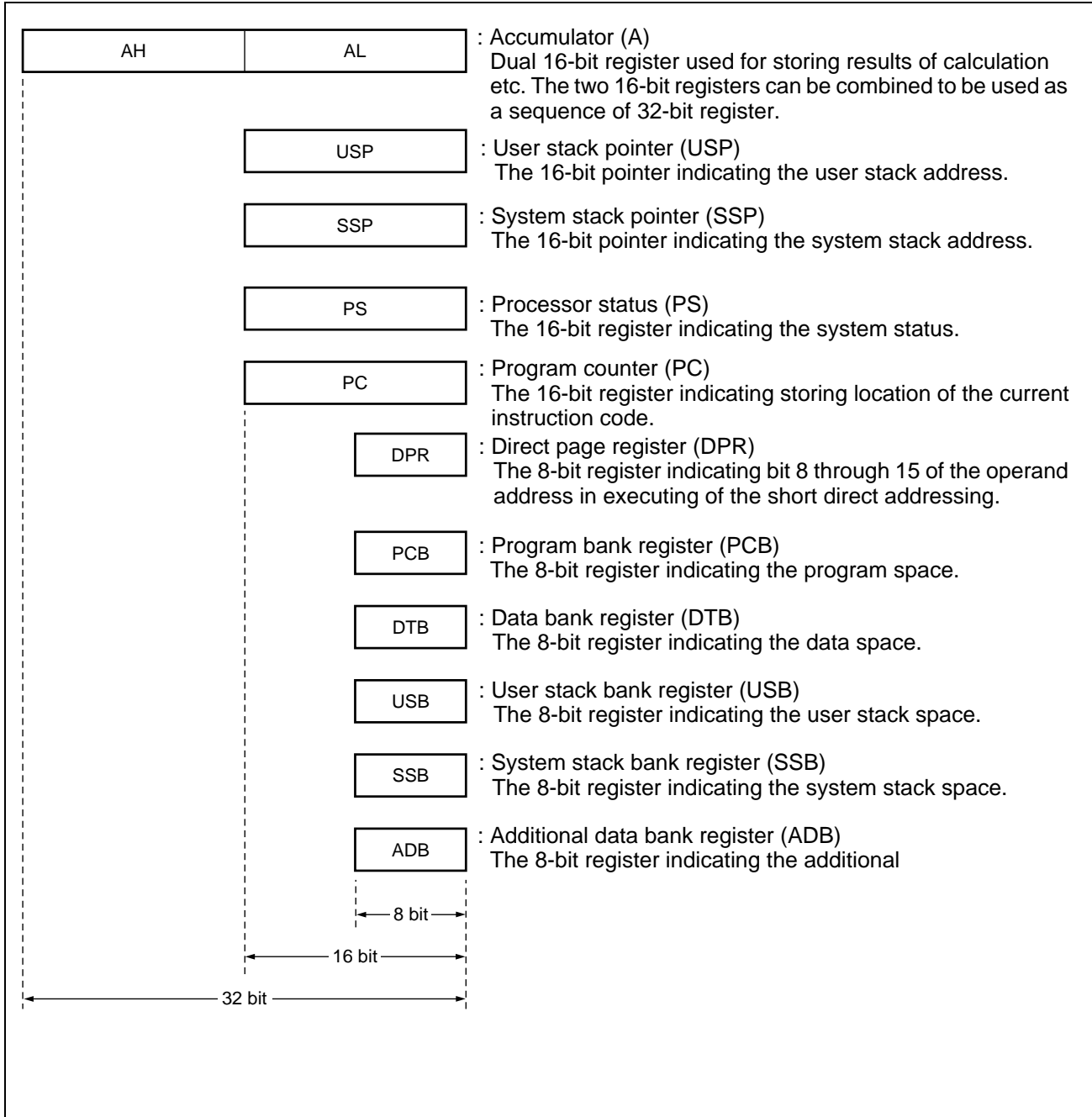

- General-purpose registers

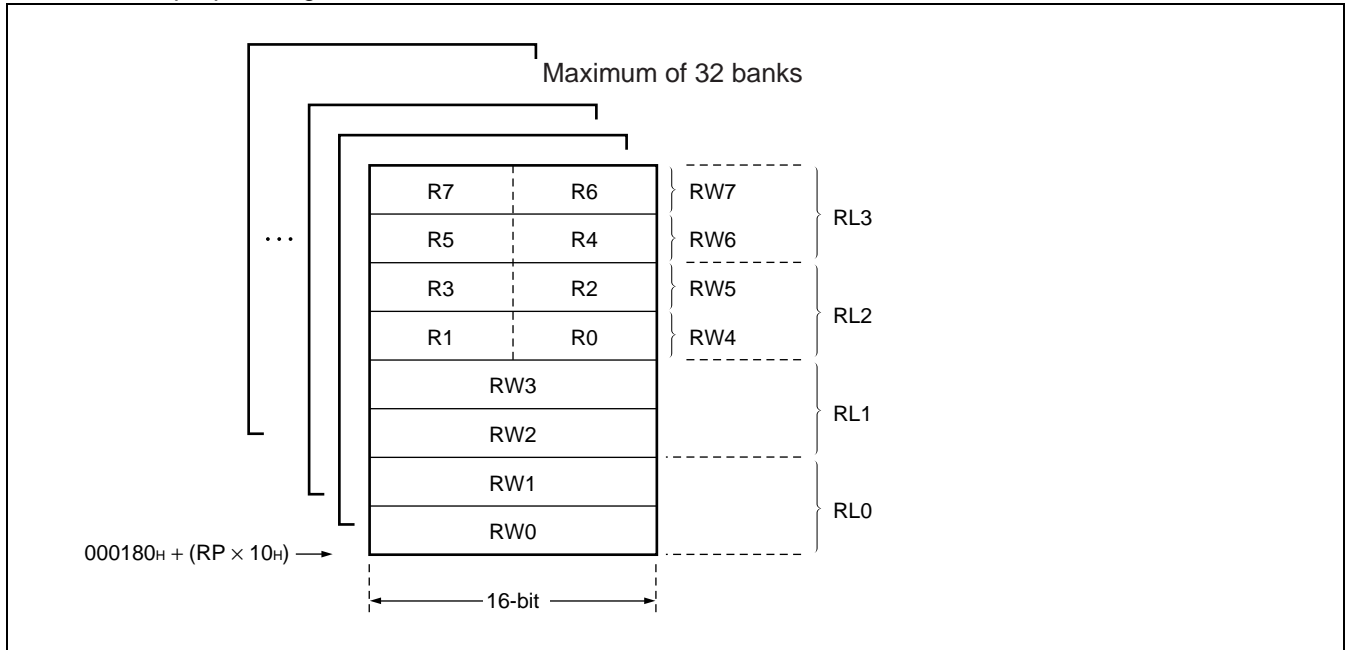

- Processor status (PS)

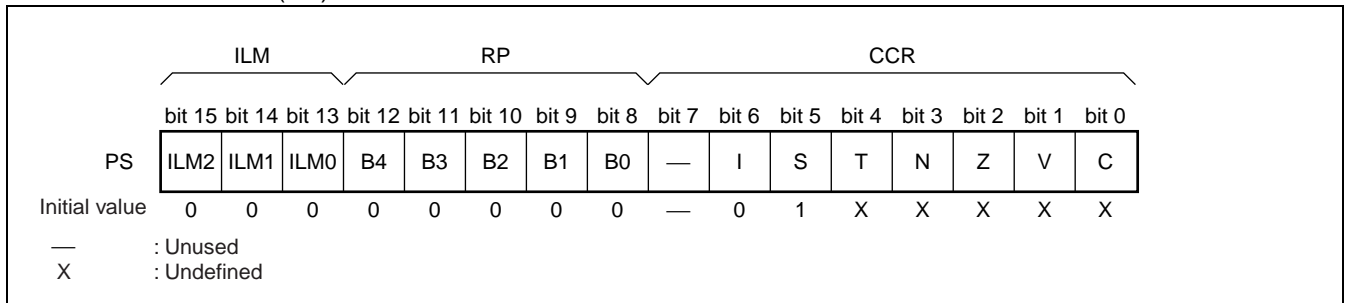

# MB90820 Series

## ■ I/O MAP

Address	Abbreviation	Register	Byte access	Word access	Resource name	Initial value
000000 <sub>H</sub>	PDR0	Port 0 data register	R/W	R/W	Port 0	XXXXXXXX <sub>B</sub>
000001 <sub>H</sub>	PDR1	Port 1 data register	R/W	R/W	Port 1	XXXXXXXX <sub>B</sub>
000002 <sub>H</sub>	PDR2	Port 2 data register	R/W	R/W	Port 2	XXXXXXXX <sub>B</sub>
000003 <sub>H</sub>	PDR3	Port 3 data register	R/W	R/W	Port 3	XXXXXXXX <sub>B</sub>
000004 <sub>H</sub>	PDR4	Port 4 data register	R/W	R/W	Port 4	XXXXXXXX <sub>B</sub>
000005 <sub>H</sub>	PDR5	Port 5 data register	R/W	R/W	Port 5	XXXXXXXX <sub>B</sub>
000006 <sub>H</sub>	PDR6	Port 6 data register	R/W	R/W	Port 6	XXXXXXXX <sub>B</sub>
000007 <sub>H</sub>	PDR7	Port 7 data register	R/W	R/W	Port 7	XXXXXXXX <sub>B</sub>
000008 <sub>H</sub>	PDR8	Port 8 data register	R/W	R/W	Port 8	XXXXXXXX <sub>B</sub>
000009 <sub>H</sub> to 00000F <sub>H</sub>	Prohibited area					
000010 <sub>H</sub>	DDR0	Port 0 data direction register	R/W	R/W	Port 0	00000000 <sub>B</sub>
000011 <sub>H</sub>	DDR1	Port 1 data direction register	R/W	R/W	Port 1	00000000 <sub>B</sub>
000012 <sub>H</sub>	DDR2	Port 2 data direction register	R/W	R/W	Port 2	00000000 <sub>B</sub>
000013 <sub>H</sub>	DDR3	Port 3 data direction register	R/W	R/W	Port 3	00000000 <sub>B</sub>
000014 <sub>H</sub>	DDR4	Port 4 data direction register	R/W	R/W	Port 4	00000000 <sub>B</sub>
000015 <sub>H</sub>	DDR5	Port 5 data direction register	R/W	R/W	Port 5	XXXXXXXX00 <sub>B</sub>
000016 <sub>H</sub>	DDR6	Port 6 data direction register	R/W	R/W	Port 6	00000000 <sub>B</sub>
000017 <sub>H</sub>	DDR7	Port 7 data direction register	R/W	R/W	Port 7	00000000 <sub>B</sub>
000018 <sub>H</sub>	DDR8	Port 8 data direction register	R/W	R/W	Port 8	00000000 <sub>B</sub>
000019 <sub>H</sub> to 00001F <sub>H</sub>	Prohibited area					
000020 <sub>H</sub>	SMR0	Serial mode register ch0	R/W	R/W	UART ch0	00000000 <sub>B</sub>
000021 <sub>H</sub>	SCR0	Serial control register ch0	W, R/W	W, R/W		0000100 <sub>B</sub>
000022 <sub>H</sub>	SIDR0 / SODR0	Serial input data register ch0 / Serial output data register ch0	R/W	R/W		XXXXXXXX <sub>B</sub>
000023 <sub>H</sub>	SSR0	Serial status register ch0	R, R/W	R, R/W		00001000 <sub>B</sub>
000024 <sub>H</sub>	SMR1	Serial mode register ch1	R/W	R/W	UART ch1	00000000 <sub>B</sub>
000025 <sub>H</sub>	SCR1	Serial control register ch1	W, R/W	W, R/W		0000100 <sub>B</sub>
000026 <sub>H</sub>	SIDR1 / SODR1	Serial input data register ch1 / Serial output data register ch1	R/W	R/W		XXXXXXXX <sub>B</sub>
000027 <sub>H</sub>	SSR1	Serial status register ch1	R, R/W	R, R/W		00001000 <sub>B</sub>
000028 <sub>H</sub>	PWCSL1	PWC control status register ch1	R/W	R/W	PWC timer ch1	00000000 <sub>B</sub>
000029 <sub>H</sub>	PWCSH1		R, R/W	R, R/W		00000000 <sub>B</sub>
00002A <sub>H</sub>	PWC1	PWC data buffer register ch1	—	R/W		XXXXXXXX <sub>B</sub>
00002B <sub>H</sub>			XXXXXXXX <sub>B</sub>			
00002C <sub>H</sub>	DIV1	Divide ratio control register ch1	R/W	R/W		XXXXXXXX00 <sub>B</sub>

(Continued)

# MB90820 Series

Address	Abbreviation	Register	Byte access	Word access	Resource name	Initial value	
00002D <sub>H</sub> , 00002E <sub>H</sub>	Prohibited area						
00002F <sub>H</sub>	PCKCR	PLL clock control register	W	W	PLL	XXXX0000 <sub>B</sub>	
000030 <sub>H</sub>	ENIR	DTP / Interrupt enable register	R/W	R/W	DTP/ external interrupt ch0 to ch7	00000000 <sub>B</sub>	
000031 <sub>H</sub>	EIRR	DTP / Interrupt cause register	R/W	R/W		XXXXXXXX <sub>B</sub>	
000032 <sub>H</sub>	ELVRL	Request level setting register (lower byte)	R/W	R/W		00000000 <sub>B</sub>	
000033 <sub>H</sub>	ELVRH	Request level setting register (higher byte)	R/W	R/W		00000000 <sub>B</sub>	
000034 <sub>H</sub>	Prohibited area						
000035 <sub>H</sub>	CDCR0	Clock division ratio control register ch0	R/W	R/W	Communication prescaler ch0	00XXX000 <sub>B</sub>	
000036 <sub>H</sub>	Prohibited area						
000037 <sub>H</sub>	CDCR1	Clock division ratio control register ch1	R/W	R/W	Communication prescaler ch1	00XXX000 <sub>B</sub>	
000038 <sub>H</sub>	PDCR0	PPG down counter register ch0	—	R	16-bit PPG timer ch0	11111111 <sub>B</sub>	
000039 <sub>H</sub>						11111111 <sub>B</sub>	
00003A <sub>H</sub>	PCSR0	PPG period setting register ch0	—	W		XXXXXXXX <sub>B</sub>	
00003B <sub>H</sub>						XXXXXXXX <sub>B</sub>	
00003C <sub>H</sub>	PDUT0	PPG duty setting register ch0	—	W		XXXXXXXX <sub>B</sub>	
00003D <sub>H</sub>						XXXXXXXX <sub>B</sub>	
00003E <sub>H</sub>	PCNTL0	PPG control status register ch0	R/W	R/W		XX000000 <sub>B</sub>	
00003F <sub>H</sub>	PCNTH0		R/W	R/W		00000000 <sub>B</sub>	
000040 <sub>H</sub>	PDCR1	PPG down counter register ch1	—	R		16-bit PPG timer ch1	11111111 <sub>B</sub>
000041 <sub>H</sub>							11111111 <sub>B</sub>
000042 <sub>H</sub>	PCSR1	PPG period setting register ch1	—	W	XXXXXXXX <sub>B</sub>		
000043 <sub>H</sub>					XXXXXXXX <sub>B</sub>		
000044 <sub>H</sub>	PDUT1	PPG duty setting register ch1	—	W	XXXXXXXX <sub>B</sub>		
000045 <sub>H</sub>					XXXXXXXX <sub>B</sub>		
000046 <sub>H</sub>	PCNTL1	PPG control status register ch1	R/W	R/W	XX000000 <sub>B</sub>		
000047 <sub>H</sub>	PCNTH1		R/W	R/W	00000000 <sub>B</sub>		
000048 <sub>H</sub>	PDCR2	PPG down counter register ch2	—	R	16-bit PPG timer ch2		11111111 <sub>B</sub>
000049 <sub>H</sub>							11111111 <sub>B</sub>
00004A <sub>H</sub>	PCSR2	PPG period setting register ch2	—	W		XXXXXXXX <sub>B</sub>	
00004B <sub>H</sub>						XXXXXXXX <sub>B</sub>	
00004C <sub>H</sub>	PDUT2	PPG duty setting register ch2	—	W		XXXXXXXX <sub>B</sub>	
00004D <sub>H</sub>						XXXXXXXX <sub>B</sub>	
00004E <sub>H</sub>	PCNTL2	PPG control status register ch2	R/W	R/W		XX000000 <sub>B</sub>	
00004F <sub>H</sub>	PCNTH2		R/W	R/W		00000000 <sub>B</sub>	

(Continued)

# MB90820 Series

Address	Abbreviation	Register	Byte access	Word access	Resource name	Initial value	
000050 <sub>H</sub>	TMRR0	16-bit timer register ch0	—	R/W	Waveform generator	XXXXXXXX <sub>B</sub>	
000051 <sub>H</sub>						XXXXXXXX <sub>B</sub>	
000052 <sub>H</sub>	TMRR1	16-bit timer register ch1	—	R/W		XXXXXXXX <sub>B</sub>	
000053 <sub>H</sub>						XXXXXXXX <sub>B</sub>	
000054 <sub>H</sub>	TMRR2	16-bit timer register ch2	—	R/W		XXXXXXXX <sub>B</sub>	
000055 <sub>H</sub>						XXXXXXXX <sub>B</sub>	
000056 <sub>H</sub>	DTCR0	16-bit timer control register ch0	R/W	R/W		00000000 <sub>B</sub>	
000057 <sub>H</sub>	DTCR1	16-bit timer control register ch1	R/W	R/W		00000000 <sub>B</sub>	
000058 <sub>H</sub>	DTCR2	16-bit timer control register ch2	R/W	R/W		00000000 <sub>B</sub>	
000059 <sub>H</sub>	SIGCR	Waveform control register	R/W	R/W		00000000 <sub>B</sub>	
00005A <sub>H</sub>	CPCLRB / CPCLR	Compare clear buffer register / Compare clear register	—	R/W	16-bit free-running timer	11111111 <sub>B</sub>	
00005B <sub>H</sub>						11111111 <sub>B</sub>	
00005C <sub>H</sub>	TCDT	Timer data register	—	R/W		00000000 <sub>B</sub>	
00005D <sub>H</sub>						00000000 <sub>B</sub>	
00005E <sub>H</sub>	TCCSL	Timer control status register (lower)	R/W	R/W	16-bit free-running timer	X0000000 <sub>B</sub>	
00005F <sub>H</sub>	TCCSH	Timer control status register (upper)	R/W	R/W		00000000 <sub>B</sub>	
000060 <sub>H</sub>	IPCP0	Input capture data register ch0	—	R	16-bit input capture (ch0 to ch3)	XXXXXXXX <sub>B</sub>	
000061 <sub>H</sub>						XXXXXXXX <sub>B</sub>	
000062 <sub>H</sub>	IPCP1	Input capture data register ch1	—	R		XXXXXXXX <sub>B</sub>	
000063 <sub>H</sub>						XXXXXXXX <sub>B</sub>	
000064 <sub>H</sub>	IPCP2	Input capture data register ch2	—	R		XXXXXXXX <sub>B</sub>	
000065 <sub>H</sub>						XXXXXXXX <sub>B</sub>	
000066 <sub>H</sub>	IPCP3	Input capture data register ch3	—	R		XXXXXXXX <sub>B</sub>	
000067 <sub>H</sub>						XXXXXXXX <sub>B</sub>	
000068 <sub>H</sub>	PICSL01	Input capture control status register ch0,ch1 (lower)	R/W	R/W		00000000 <sub>B</sub>	
000069 <sub>H</sub>	PICSH01	PPG output control / Input capture control status register ch0,ch1 (upper)	R/W	R/W		00000000 <sub>B</sub>	
00006A <sub>H</sub>	ICSL23	Input capture control status register ch2,ch3 (lower)	R/W	R/W		00000000 <sub>B</sub>	
00006B <sub>H</sub>	ICSH23	Input capture control status register ch2,ch3 (upper)	R	R		XXXXXXXX00 <sub>B</sub>	
00006C <sub>H</sub> to 00006E <sub>H</sub>	Prohibited area						

(Continued)



# MB90820 Series

Address	Abbreviation	Register	Byte access	Word access	Resource name	Initial value
00006F <sub>H</sub>	ROMM	ROM mirroring function selection register	W	W	ROM mirroring function	XXXXXXXX <sub>1B</sub>
000070 <sub>H</sub>	OCCPB0 / OCCP0	Output compare buffer register / Output compare register ch0	—	R/W	Output compare (ch0 to ch5)	XXXXXXXX <sub>B</sub>
000071 <sub>H</sub>						XXXXXXXX <sub>B</sub>
000072 <sub>H</sub>	OCCPB1 / OCCP1	Output compare buffer register / Output compare register ch1	—	R/W		XXXXXXXX <sub>B</sub>
000073 <sub>H</sub>						XXXXXXXX <sub>B</sub>
000074 <sub>H</sub>	OCCPB2 / OCCP2	Output compare buffer register / Output compare register ch2	—	R/W		XXXXXXXX <sub>B</sub>
000075 <sub>H</sub>						XXXXXXXX <sub>B</sub>
000076 <sub>H</sub>	OCCPB3 / OCCP3	Output compare buffer register / Output compare register ch3	—	R/W		XXXXXXXX <sub>B</sub>
000077 <sub>H</sub>						XXXXXXXX <sub>B</sub>
000078 <sub>H</sub>	OCCPB4 / OCCP4	Output compare buffer register / Output compare register ch4	—	R/W		XXXXXXXX <sub>B</sub>
000079 <sub>H</sub>						XXXXXXXX <sub>B</sub>
00007A <sub>H</sub>	OCCPB5 / OCCP5	Output compare buffer register / Output compare register ch5	—	R/W	XXXXXXXX <sub>B</sub>	
00007B <sub>H</sub>					XXXXXXXX <sub>B</sub>	
00007C <sub>H</sub>	OCS0	Compare control register ch0	R/W	R/W		00001100 <sub>B</sub>
00007D <sub>H</sub>	OCS1	Compare control register ch1	R/W	R/W		X1100000 <sub>B</sub>
00007E <sub>H</sub>	OCS2	Compare control register ch2	R/W	R/W		00001100 <sub>B</sub>
00007F <sub>H</sub>	OCS3	Compare control register ch3	R/W	R/W		X1100000 <sub>B</sub>
000080 <sub>H</sub>	OCS4	Compare control register ch4	R/W	R/W		00001100 <sub>B</sub>
000081 <sub>H</sub>	OCS5	Compare control register ch5	R/W	R/W		X1100000 <sub>B</sub>
000082 <sub>H</sub>	TMCSRL0	Timer control status register ch0 (lower)	R/W	R/W	16-bit reload timer (ch0)	00000000 <sub>B</sub>
000083 <sub>H</sub>	TMCSRH0	Timer control status register ch0 (upper)	R/W	R/W		XXX10000 <sub>B</sub>
000084 <sub>H</sub>	TMR0 / TMRD0	16 bit timer register ch0 / 16-bit reload register ch0	—	R/W		XXXXXXXX <sub>B</sub>
000085 <sub>H</sub>						XXXXXXXX <sub>B</sub>
000086 <sub>H</sub>	TMCSRL1	Timer control status register ch1 (lower)	R/W	R/W	16-bit reload timer (ch1)	00000000 <sub>B</sub>
000087 <sub>H</sub>	TMCSRH1	Timer control status register ch1 (upper)	R/W	R/W		XXX10000 <sub>B</sub>
000088 <sub>H</sub>	TMR1 / TMRD1	16 bit timer register ch1 / 16-bit reload register ch1	—	R/W		XXXXXXXX <sub>B</sub>
000089 <sub>H</sub>						XXXXXXXX <sub>B</sub>
00008A <sub>H</sub> , 00008B <sub>H</sub>	Prohibited area					
00008C <sub>H</sub>	RDR0	Port 0 pull-up resistor setting register	R/W	R/W	Port 0	00000000 <sub>B</sub>
00008D <sub>H</sub>	RDR1	Port 1 pull-up resistor setting register	R/W	R/W	Port 1	00000000 <sub>B</sub>

(Continued)

# MB90820 Series

Address	Abbreviation	Register	Byte access	Word access	Resource name	Initial value
00008E <sub>H</sub>	RDR2	Port 2 pull-up resistor setting register	R/W	R/W	Port 2	00000000 <sub>B</sub>
00008F <sub>H</sub>	RDR3	Port 3 pull-up resistor setting register	R/W	R/W	Port 3	00000000 <sub>B</sub>
000090 <sub>H</sub> to 00009D <sub>H</sub>	Prohibited area					
00009E <sub>H</sub>	PACSR	Program address detection control status register	R/W	R/W	Address match detection	XXXX0000 <sub>B</sub>
00009F <sub>H</sub>	DIRR	Delayed interrupt cause / clear register	R/W	R/W	Delayed interrupt	XXXXXXX0 <sub>B</sub>
0000A0 <sub>H</sub>	LPMCR	Low-power consumption mode control register	W, R/W	W, R/W	Low-power consumption control register	00011000 <sub>B</sub>
0000A1 <sub>H</sub>	CKSCR	Clock selection register	R, R/W	R, R/W		11111100 <sub>B</sub>
0000A2 <sub>H</sub> to 0000A7 <sub>H</sub>	Prohibited area					
0000A8 <sub>H</sub>	WDTC	Watchdog timer control register	R, R/W	R, R/W	Watchdog timer	XXXXX111 <sub>B</sub>
0000A9 <sub>H</sub>	TBTC	Timebase timer control register	W, R/W	W, R/W	Timebase timer	1XX00100 <sub>B</sub>
0000AA <sub>H</sub> to 0000AD <sub>H</sub>	Prohibited area					
0000AE <sub>H</sub>	FMCS	Flash memory control status register	R, R/W	R, R/W	Flash memory interface circuit	000X0000 <sub>B</sub>
0000AF <sub>H</sub>	Prohibited area					
0000B0 <sub>H</sub>	ICR00	Interrupt control register 00	R/W	R/W	Interrupt controller	00000111 <sub>B</sub>
0000B1 <sub>H</sub>	ICR01	Interrupt control register 01	R/W	R/W		00000111 <sub>B</sub>
0000B2 <sub>H</sub>	ICR02	Interrupt control register 02	R/W	R/W		00000111 <sub>B</sub>
0000B3 <sub>H</sub>	ICR03	Interrupt control register 03	R/W	R/W		00000111 <sub>B</sub>
0000B4 <sub>H</sub>	ICR04	Interrupt control register 04	R/W	R/W		00000111 <sub>B</sub>
0000B5 <sub>H</sub>	ICR05	Interrupt control register 05	R/W	R/W		00000111 <sub>B</sub>
0000B6 <sub>H</sub>	ICR06	Interrupt control register 06	R/W	R/W		00000111 <sub>B</sub>
0000B7 <sub>H</sub>	ICR07	Interrupt control register 07	R/W	R/W		00000111 <sub>B</sub>
0000B8 <sub>H</sub>	ICR08	Interrupt control register 08	R/W	R/W		00000111 <sub>B</sub>
0000B9 <sub>H</sub>	ICR09	Interrupt control register 09	R/W	R/W		00000111 <sub>B</sub>
0000BA <sub>H</sub>	ICR10	Interrupt control register 10	R/W	R/W		00000111 <sub>B</sub>
0000BB <sub>H</sub>	ICR11	Interrupt control register 11	R/W	R/W		00000111 <sub>B</sub>
0000BC <sub>H</sub>	ICR12	Interrupt control register 12	R/W	R/W		00000111 <sub>B</sub>
0000BD <sub>H</sub>	ICR13	Interrupt control register 13	R/W	R/W		00000111 <sub>B</sub>
0000BE <sub>H</sub>	ICR14	Interrupt control register 14	R/W	R/W		00000111 <sub>B</sub>
0000BF <sub>H</sub>	ICR15	Interrupt control register 15	R/W	R/W		00000111 <sub>B</sub>

(Continued)

(Continued)

Address	Abbreviation	Register	Byte access	Word access	Resource name	Initial value
0000C0 <sub>H</sub>	PWCSL0	PWC control status register ch0	R/W	R/W	PWC timer (ch0)	00000000 <sub>B</sub>
0000C1 <sub>H</sub>	PWCSH0		R, R/W	R, R/W		00000000 <sub>B</sub>
0000C2 <sub>H</sub>	PWC0	PWC data buffer register ch0	—	R/W		XXXXXXXX <sub>B</sub>
0000C3 <sub>H</sub>						XXXXXXXX <sub>B</sub>
0000C4 <sub>H</sub>	DIV0	Divide ratio control register ch0	R/W	R/W		XXXXXXXX00 <sub>B</sub>
0000C5 <sub>H</sub>	ADER0	A/D input enable register 0	R/W	R/W	Port 6, A/D	11111111 <sub>B</sub>
0000C6 <sub>H</sub>	ADCS0	A/D control status register 0	R/W	R/W	8/10-bit A/D converter	000XXXX0 <sub>B</sub>
0000C7 <sub>H</sub>	ADCS1	A/D control status register 1	W, R/W	W, R/W		0000000X <sub>B</sub>
0000C8 <sub>H</sub>	ADCR0	A/D data register 0	R	R		XXXXXXXX <sub>B</sub>
0000C9 <sub>H</sub>	ADCR1	A/D data register 1	R	R		XXXXXXXX <sub>B</sub>
0000CA <sub>H</sub>	ADSR0	A/D setting register 0	R/W	R/W		00000000 <sub>B</sub>
0000CB <sub>H</sub>	ADSR1	A/D setting register 1	R/W	R/W		00000000 <sub>B</sub>
0000CC <sub>H</sub>	DAT0	D/A data register 0	R/W	R/W	8-bit D/A converter	XXXXXXXX <sub>B</sub>
0000CD <sub>H</sub>	DAT1	D/A data register 1	R/W	R/W		XXXXXXXX <sub>B</sub>
0000CE <sub>H</sub>	DACR0	D/A control register 0	R/W	R/W		XXXXXXXX0 <sub>B</sub>
0000CF <sub>H</sub>	DACR1	D/A control register 1	R/W	R/W		XXXXXXXX0 <sub>B</sub>
0000D0 <sub>H</sub>	ADER1	A/D input enable register 1	R/W	R/W	Port 7, A/D	11111111 <sub>B</sub>
0000D1 <sub>H</sub> to 0000EF <sub>H</sub>	Prohibited area					
0000F0 <sub>H</sub> to 0000FF <sub>H</sub>	External area					
001FF0 <sub>H</sub>	PADRL0	Program address detection register 0 (lower)	R/W	R/W	Address match detection	XXXXXXXX <sub>B</sub>
001FF1 <sub>H</sub>	PADRM0	Program address detection register 0 (middle)	R/W	R/W		XXXXXXXX <sub>B</sub>
001FF2 <sub>H</sub>	PADRH0	Program address detection register 0 (higher)	R/W	R/W		XXXXXXXX <sub>B</sub>
001FF3 <sub>H</sub>	PADRL1	Program address detection register 1 (lower)	R/W	R/W		XXXXXXXX <sub>B</sub>
001FF4 <sub>H</sub>	PADRM1	Program address detection register 1 (middle)	R/W	R/W		XXXXXXXX <sub>B</sub>
001FF5 <sub>H</sub>	PADRH1	Program address detection register 1 (higher)	R/W	R/W		XXXXXXXX <sub>B</sub>

- Meaning of abbreviations used for reading and writing  
R/W: Read and write enabled  
R : Read-only  
W : Write-only
- Explanation of initial values  
0 : The bit is initialized to "0".  
1 : The bit is initialized to "1".  
X : The initial value of the bit is undefined.



## ■ PERIPHERAL RESOURCES

### 1. Low-power Consumption Control Circuit

The MB90820 series has the following CPU operating mode configured by selection of an operating clock and clock operation control.

- Clock mode

PLL clock mode : A PLL clock that is a multiple of the oscillation clock (HCLK) frequency is used to operate the CPU and peripheral functions.

Main clock mode : The main clock, with a frequency one-half that of the oscillation clock (HCLK), is used to operate the CPU and peripheral functions. In main clock mode, the PLL divide circuit is inactive.

- CPU intermittent operation mode

CPU intermittent operation mode causes the CPU to operate intermittently, while high-speed clock pulses are supplied to peripheral functions, reducing power consumption. In CPU intermittent operation mode, clock pulses are supplied intermittently to the CPU when it is accessing a register, internal memory, a peripheral function, or an external unit.

- Standby mode

In standby mode, the low power consumption control circuit reduces power consumption by stopping;

- The supply of the clock to CPU (sleep mode)
- CPU and peripheral functions (timebase timer mode)
- The oscillation clock itself (stop mode)

- PLL sleep mode

PLL sleep mode is activated to stop the CPU operating clock when the microcontroller enters PLL clock mode; other components continue to operate on the PLL clock.

- Main sleep mode

Main sleep mode is activated to stop the CPU operating clock when the microcontroller enters main clock mode; other components continue to operate on the main clock.

- PLL timebase timer mode

PLL timebase timer mode causes microcontroller operation, with the exception of the oscillation clock, PLL clock and timebase timer, to stop. All functions other than the timebase timer are deactivated.

- Main timebase timer mode

Main timebase timer mode causes microcontroller operation, with the exception of the oscillation clock, main clock and the timebase timer, to stop. All functions other than the timebase timer are deactivated.

- Stop mode

Stop mode causes the source oscillation to stop. All functions are deactivated.

# MB90820 Series

## (1) Register configuration

Clock Selection Register

	15	14	13	12	11	10	9	8	⇐ Bit
Address: 00000A1 <sub>H</sub>	Reserved	MCM	WS1	WS0	Reserved	MCS	CS1	CS0	CKSCR
Read/write ⇨	R/W	R	R/W	R/W	R/W	R/W	R/W	R/W	
Initial value ⇨	1	1	1	1	1	1	0	0	

PLL Clock Control Register

	15	14	13	12	11	10	9	8	⇐ Bit
Address: 000002F <sub>H</sub>	–	–	–	–	Reserved	Reserved	Reserved	CS2	PCKCR
Read/write ⇨	–	–	–	–	W	W	W	W	
Initial value ⇨	X	X	X	X	0	0	0	0	

Low-power Consumption Mode Control Register

	7	6	5	4	3	2	1	0	⇐ Bit
Address: 0000A0 <sub>H</sub>	STP	SLP	SPL	RST	TMD	CG1	CG0	Reserved	LPMCR
Read/write ⇨	W	W	R/W	W	W	R/W	R/W	R/W	
Initial value ⇨	0	0	0	1	1	0	0	0	

## (2) Block diagram

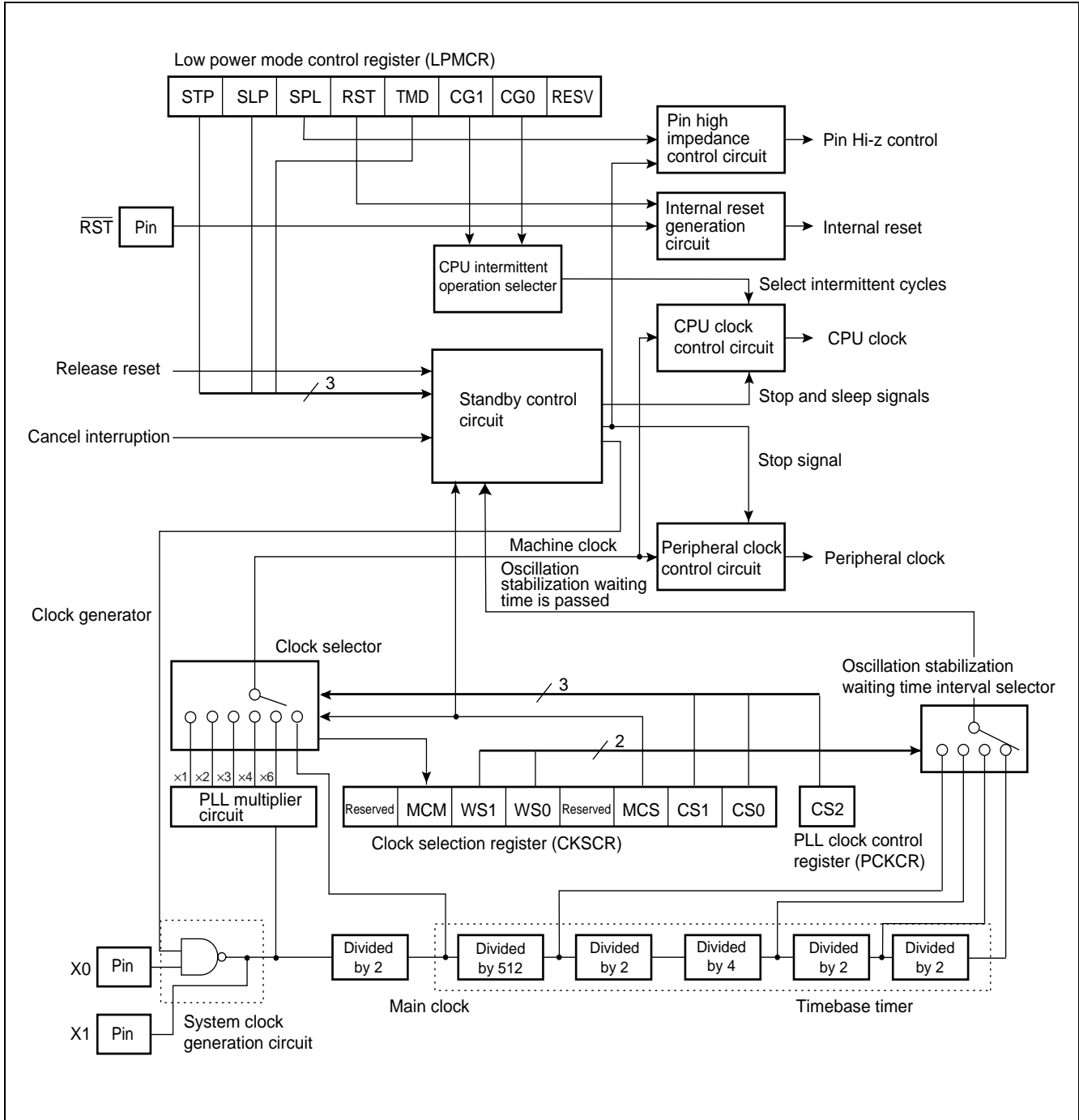

# MB90820 Series

## 2. I/O Ports

### (1) Outline of I/O ports

Each I/O port outputs data from CPU to I/O pins or inputs signals from I/O pins to CPU through port data register (PDR). Direction of the data flow (input or output) for each I/O pin can be designated in bit unit by port data direction register (DDR). The function of each port and the resource I/O multiplexed with it are described below:

- Port 0 : General-purpose I/O port/resource (PWC timer)
- Port 1 : General-purpose I/O port/resources (DTP / Multi-functional timer)
- Port 2 : General-purpose I/O port/resource (16-bit reload timer)
- Port 3 : General-purpose I/O port/resource (16-bit PPG timer)
- Port 4 : General-purpose I/O port/resources (16-bit PPG timer / 16-bit reload timer / UART / PWC)
- Port 5 : General-purpose I/O port/resources (16-bit PPG timer / DTP)
- Port 6 : General-purpose I/O port/resource (8/10-bit A/D converter)
- Port 7 : General-purpose I/O port/resources (8/10-bit A/D converter / 8-bit D/A converter / UART / 16-bit free-running timer / 16-bit input capture)
- Port 8 : General-purpose I/O port/resources (16-bit input capture / Multi-functional timer)

### (2) Register configuration

Register	Read/Write	Address	Initial value
Port 0 data register (PDR0)	R/W	000000 <sub>H</sub>	XXXXXXXX <sub>B</sub>
Port 1 data register (PDR1)	R/W	000001 <sub>H</sub>	XXXXXXXX <sub>B</sub>
Port 2 data register (PDR2)	R/W	000002 <sub>H</sub>	XXXXXXXX <sub>B</sub>
Port 3 data register (PDR3)	R/W	000003 <sub>H</sub>	XXXXXXXX <sub>B</sub>
Port 4 data register (PDR4)	R/W	000004 <sub>H</sub>	XXXXXXXX <sub>B</sub>
Port 5 data register (PDR5)	R/W	000005 <sub>H</sub>	XXXXXXXX <sub>B</sub>
Port 6 data register (PDR6)	R/W	000006 <sub>H</sub>	XXXXXXXX <sub>B</sub>
Port 7 data register (PDR7)	R/W	000007 <sub>H</sub>	XXXXXXXX <sub>B</sub>
Port 8 data register (PDR8)	R/W	000008 <sub>H</sub>	XXXXXXXX <sub>B</sub>
Port 0 data direction register (DDR0)	R/W	000010 <sub>H</sub>	00000000 <sub>B</sub>
Port 1 data direction register (DDR1)	R/W	000011 <sub>H</sub>	00000000 <sub>B</sub>
Port 2 data direction register (DDR2)	R/W	000012 <sub>H</sub>	00000000 <sub>B</sub>
Port 3 data direction register (DDR3)	R/W	000013 <sub>H</sub>	00000000 <sub>B</sub>
Port 4 data direction register (DDR4)	R/W	000014 <sub>H</sub>	00000000 <sub>B</sub>
Port 5 data direction register (DDR5)	R/W	000015 <sub>H</sub>	XXXXXXXX00 <sub>B</sub>
Port 6 data direction register (DDR6)	R/W	000016 <sub>H</sub>	00000000 <sub>B</sub>
Port 7 data direction register (DDR7)	R/W	000017 <sub>H</sub>	00000000 <sub>B</sub>
Port 8 data direction register (DDR8)	R/W	000018 <sub>H</sub>	00000000 <sub>B</sub>
A/D input enable register (ADER0)	R/W	0000C5 <sub>H</sub>	11111111 <sub>B</sub>
A/D input enable register (ADER1)	R/W	0000D0 <sub>H</sub>	11111111 <sub>B</sub>
Port 0 pull-up resistor setting register (RDR0)	R/W	00008C <sub>H</sub>	00000000 <sub>B</sub>
Port 1 pull-up resistor setting register (RDR1)	R/W	00008D <sub>H</sub>	00000000 <sub>B</sub>
Port 2 pull-up resistor setting register (RDR2)	R/W	00008E <sub>H</sub>	00000000 <sub>B</sub>
Port 3 pull-up resistor setting register (RDR3)	R/W	00008F <sub>H</sub>	00000000 <sub>B</sub>

R/W: Read/write enabled

X : Undefined



### (3) Block diagram

- Block diagram of Port 0 (P00 to P06), Port 1 (P17) and Port 2 (excluding P21) pins

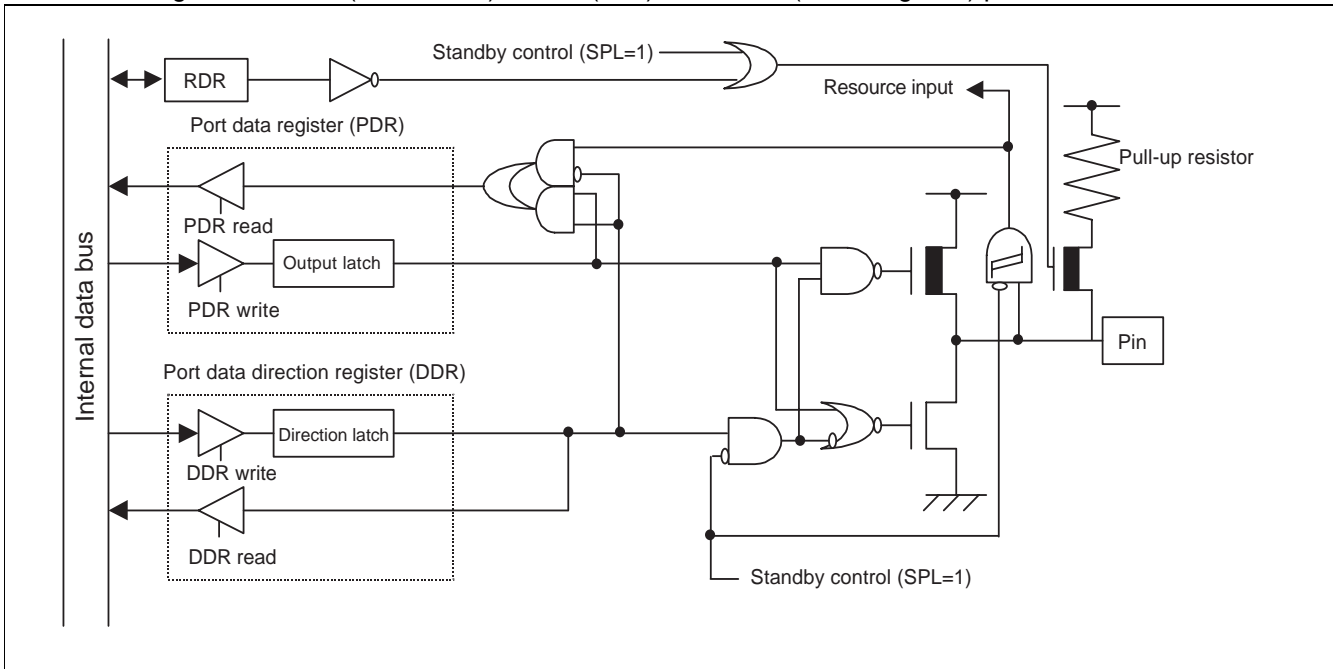

- Block diagram of Port 0 (P07) and Port 2 (P21) pins

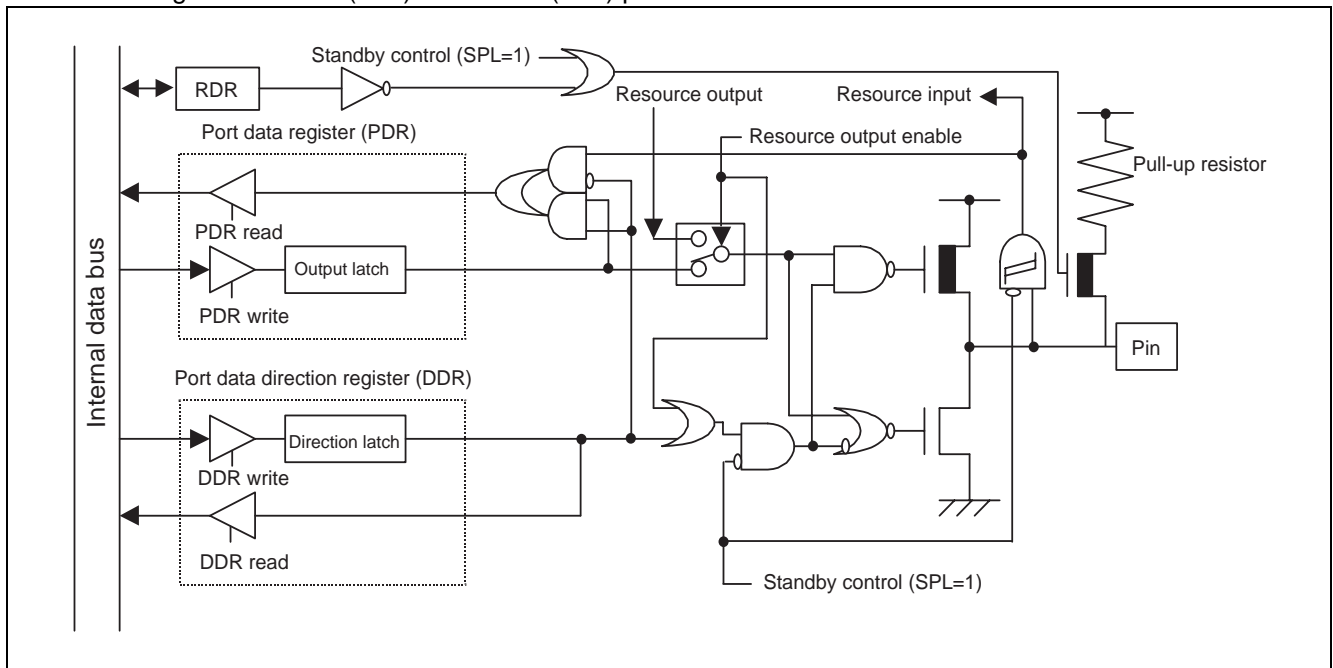

# MB90820 Series

- Block diagram of Port 1 (P10 to P16) pins

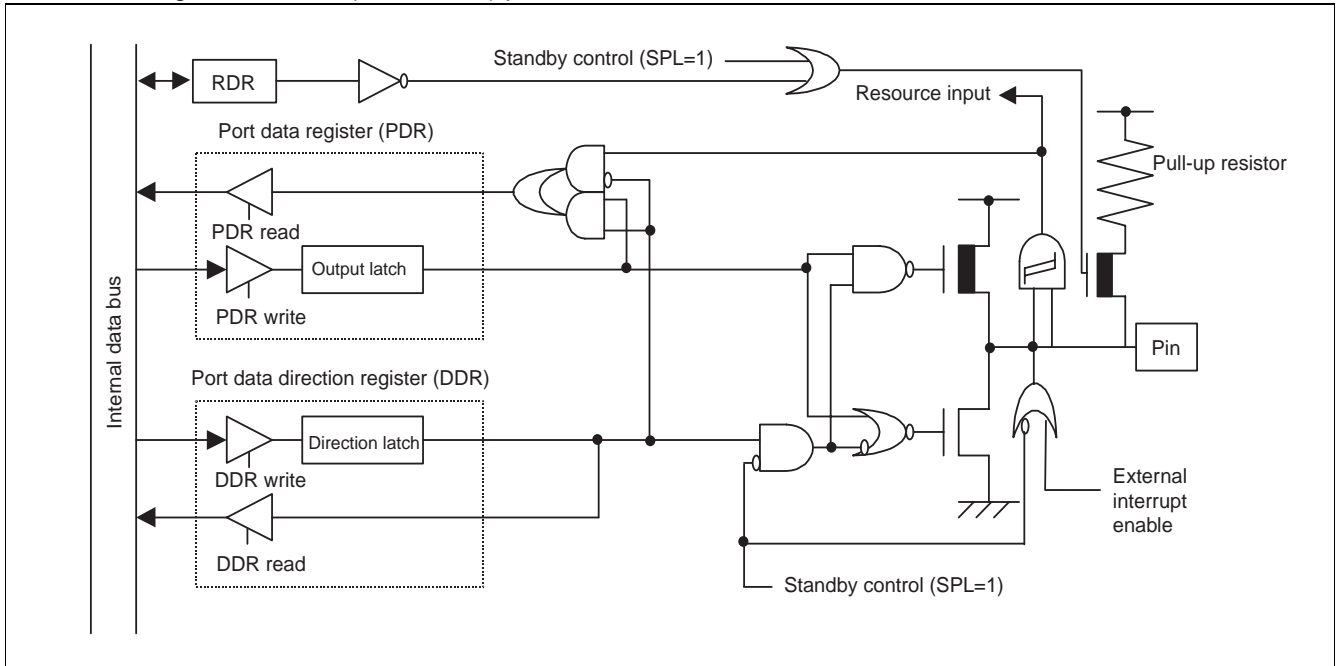

- Block diagram of Port 3 (excluding P37) pins

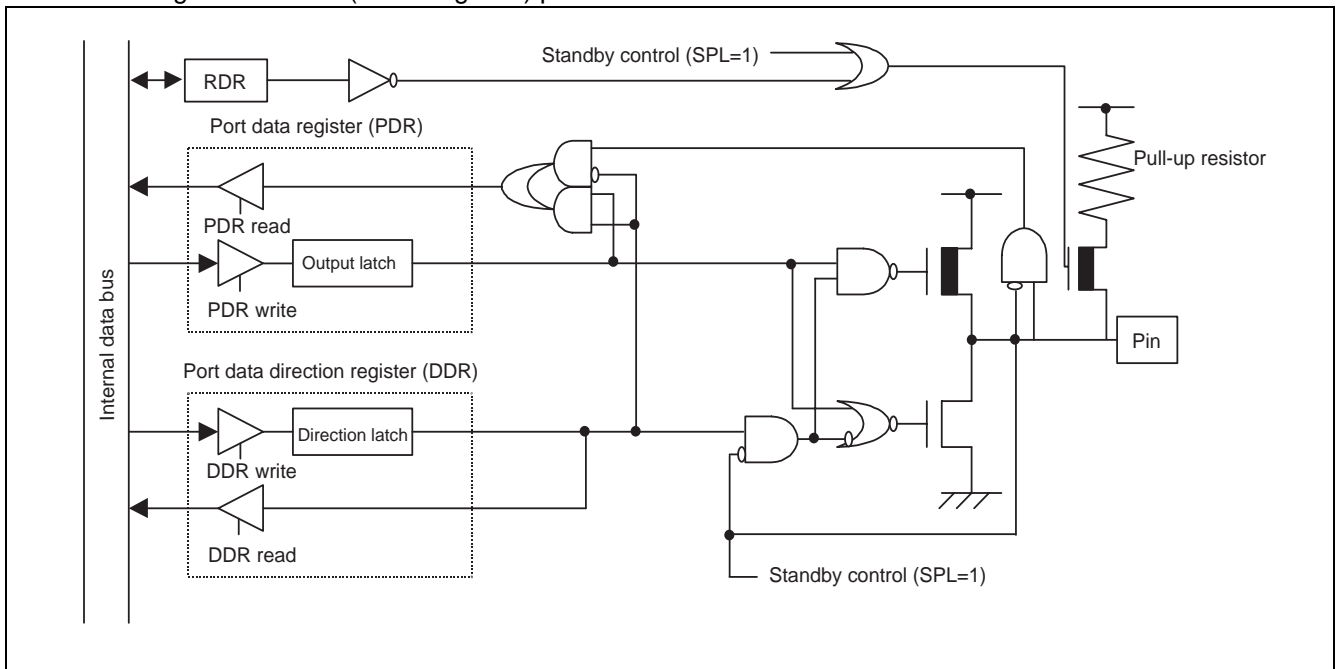

- Block diagram of Port 3 (P37) pin

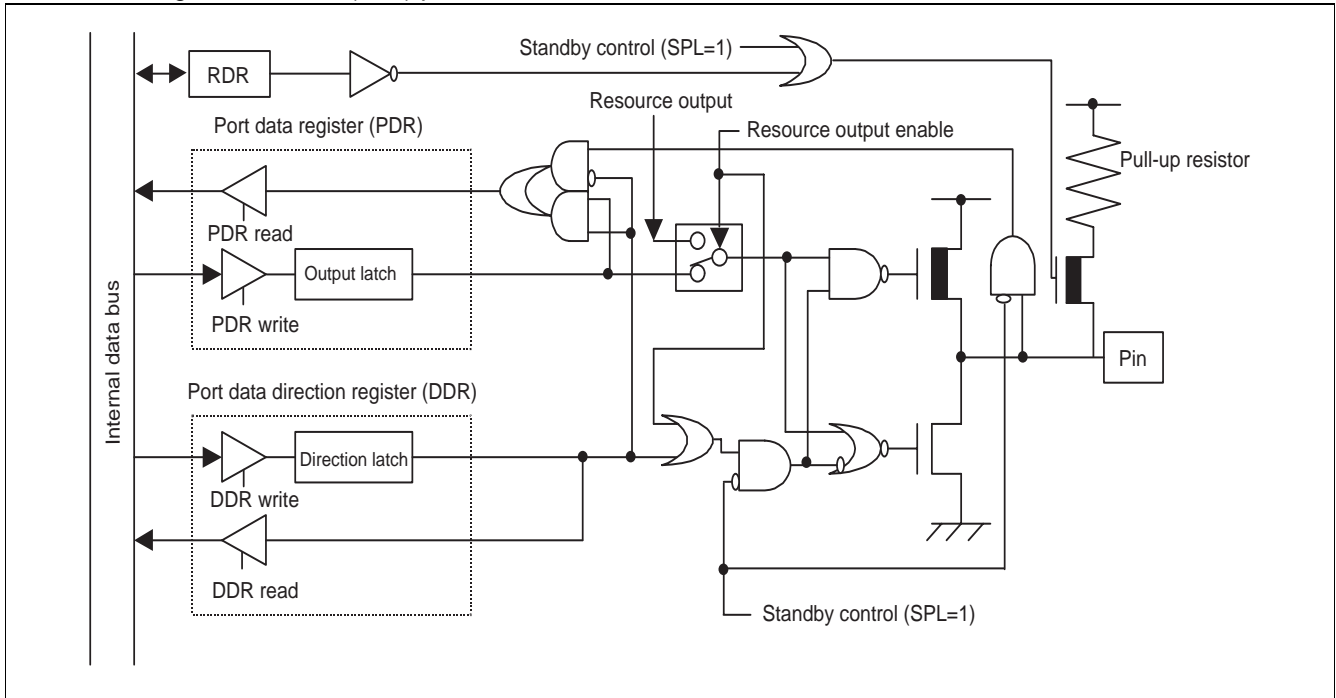

- Block diagram of Port 4 pins (excluding P41, P45 and P46) pins

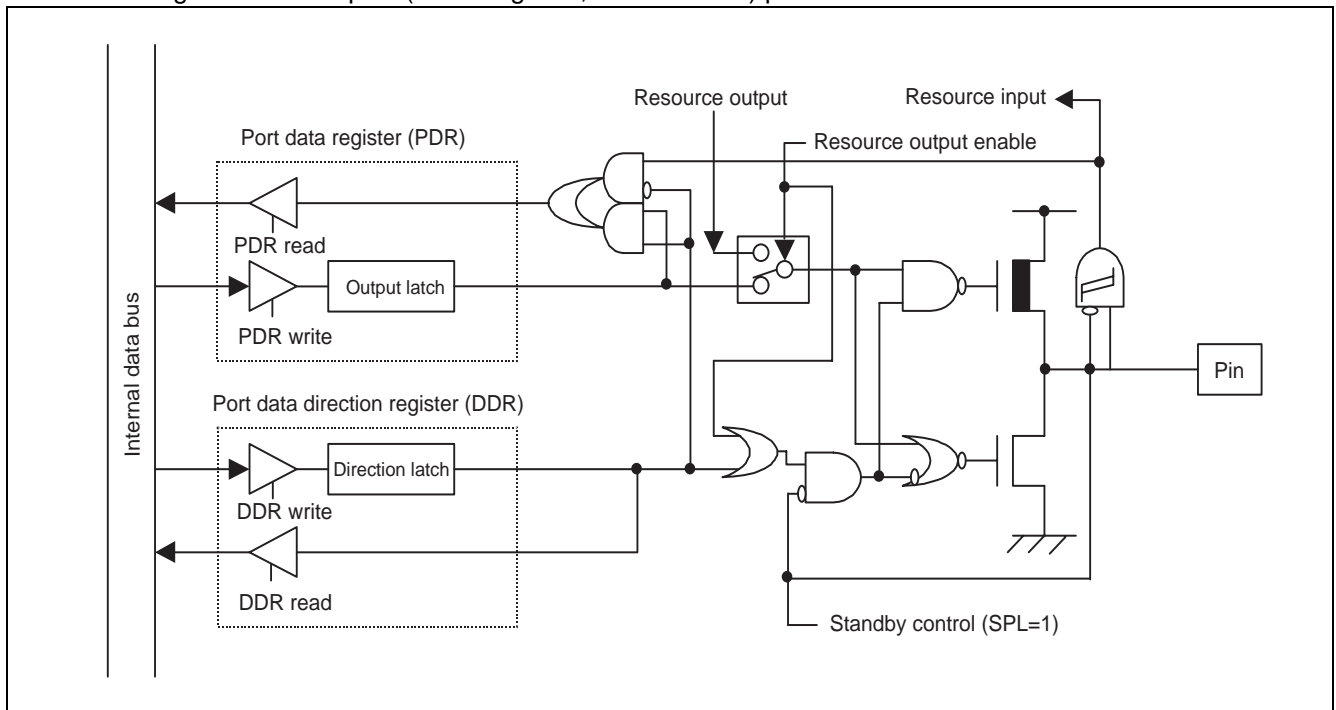

# MB90820 Series

- Block diagram of Port 4 (P41 and P46) pins

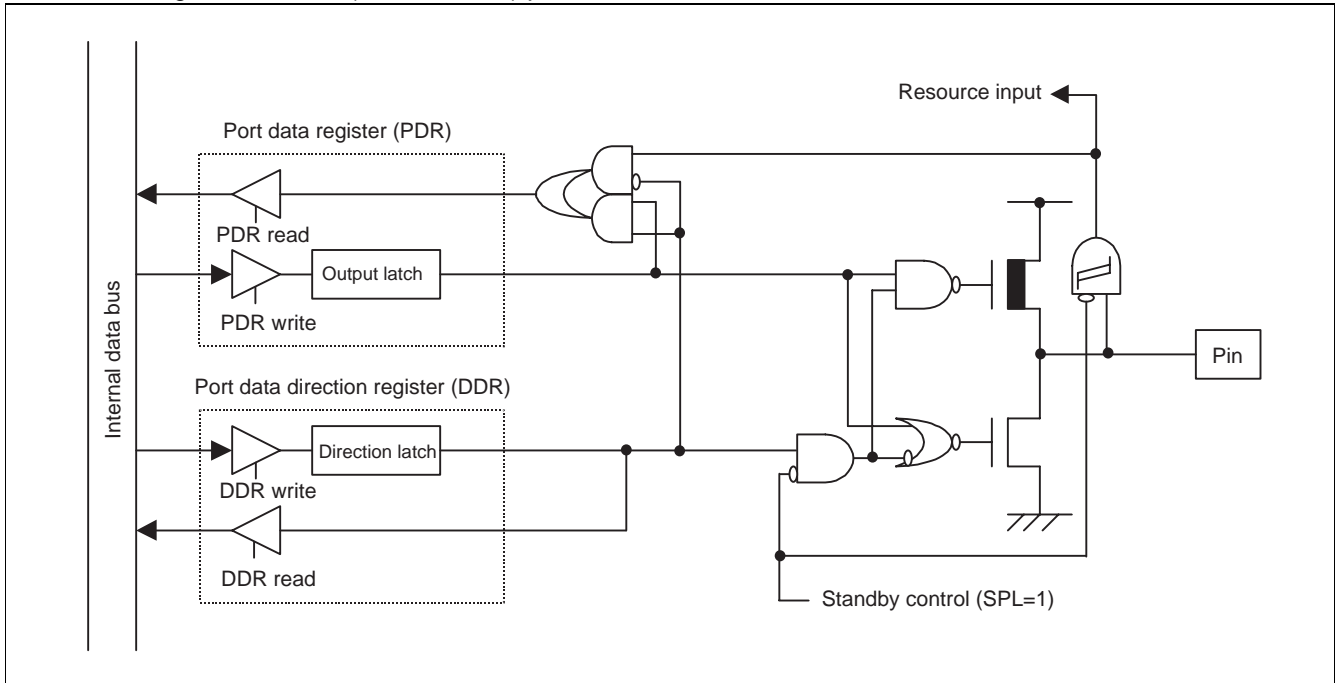

- Block diagram of P45 pin

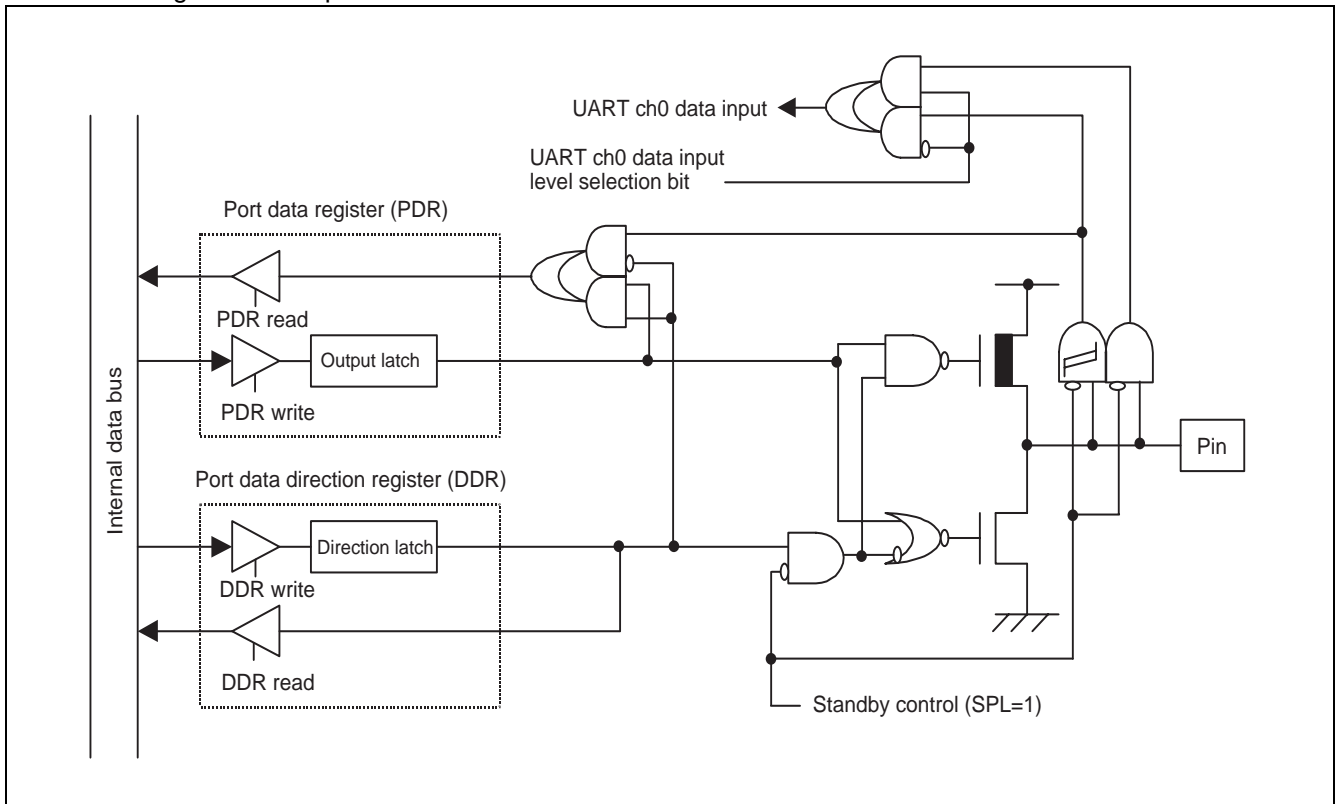

- Block diagram of Port 5 (P50) pin

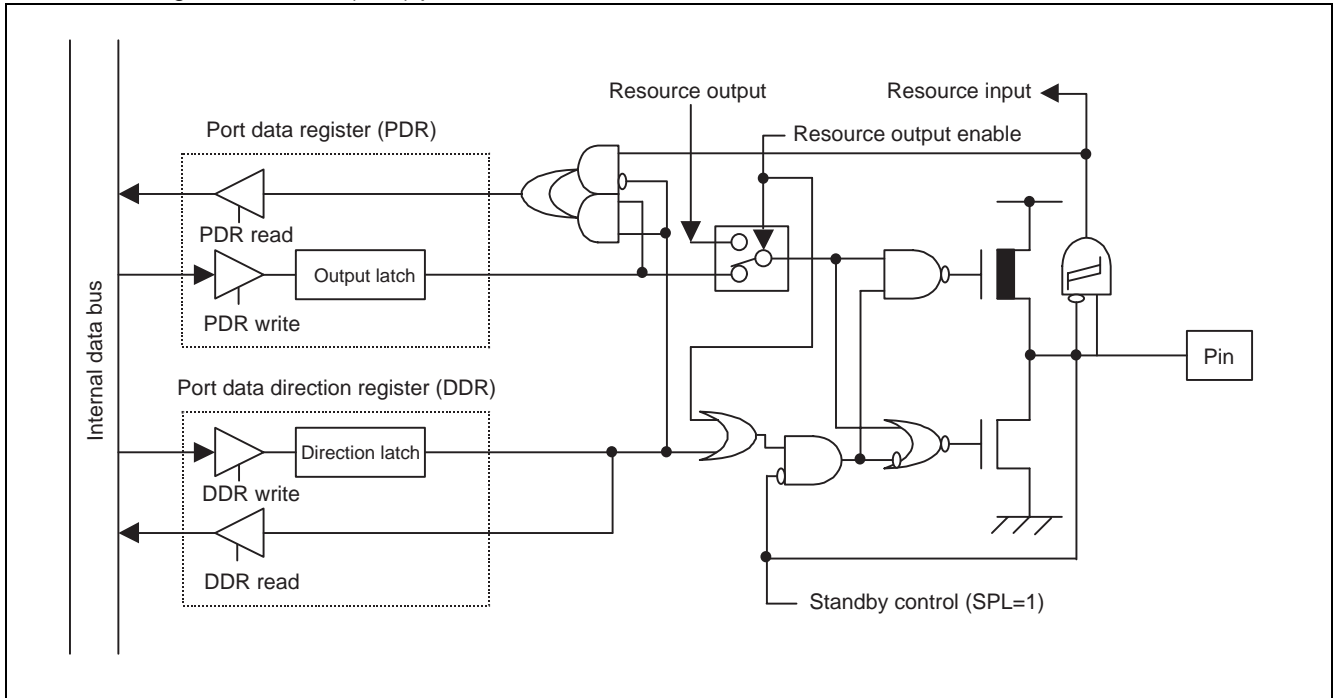

- Block diagram of Port 5 (P51) pin

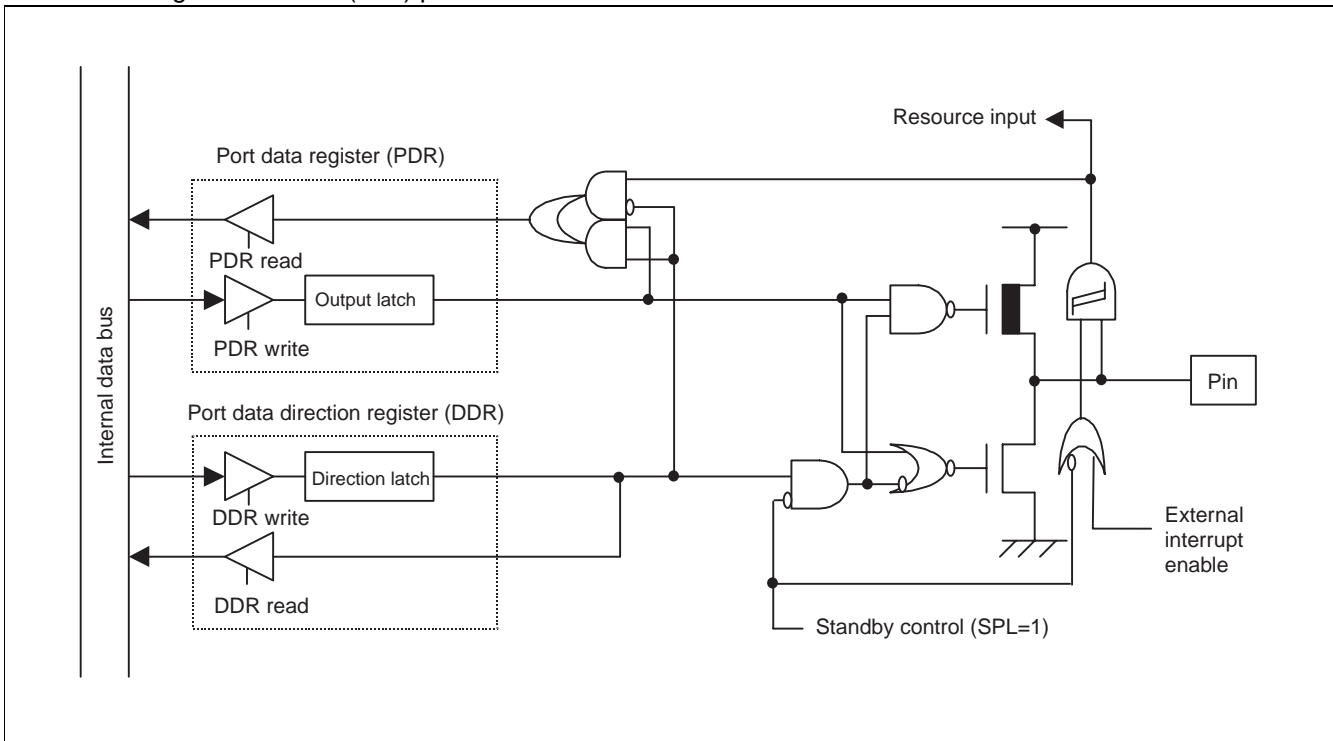

# MB90820 Series

- Block diagram of Port 6 pins

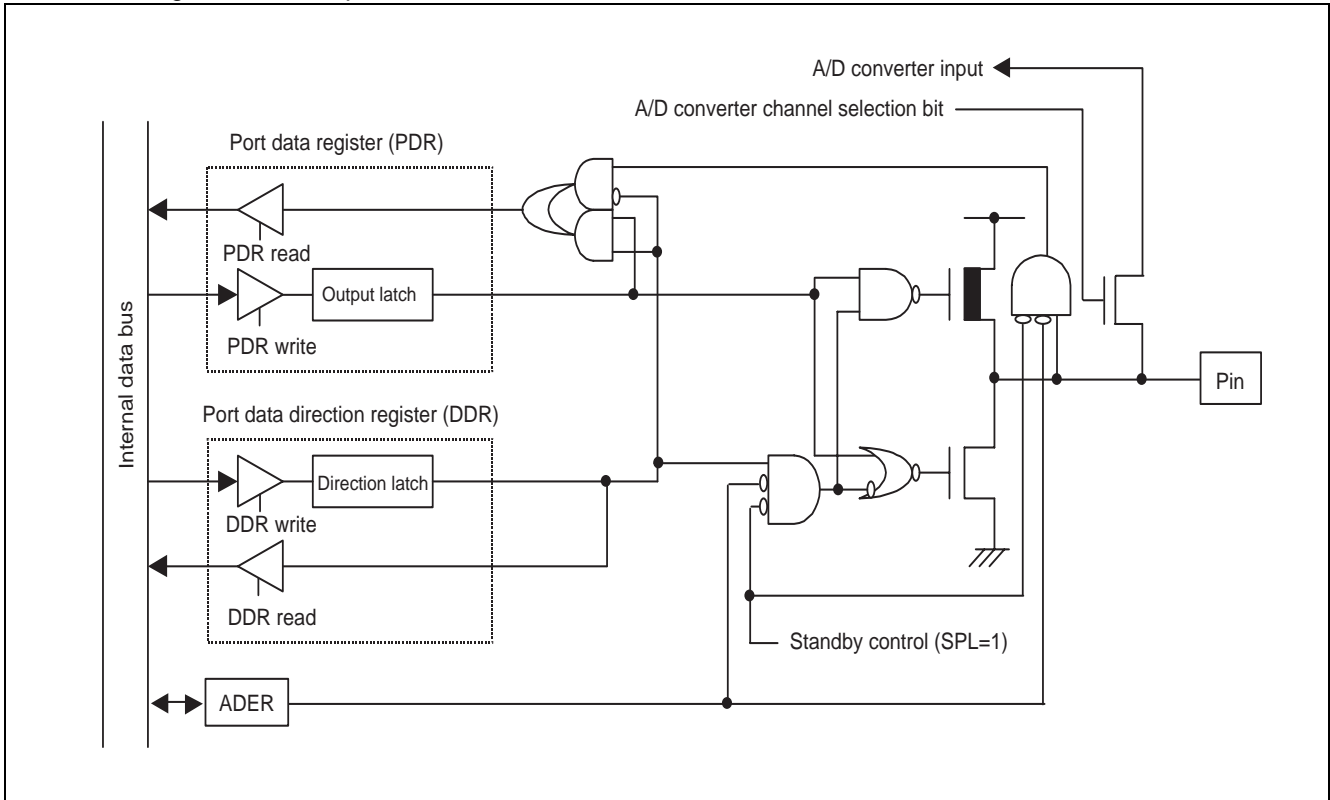

- Block diagram of Port 7 (P70 and P71) pins

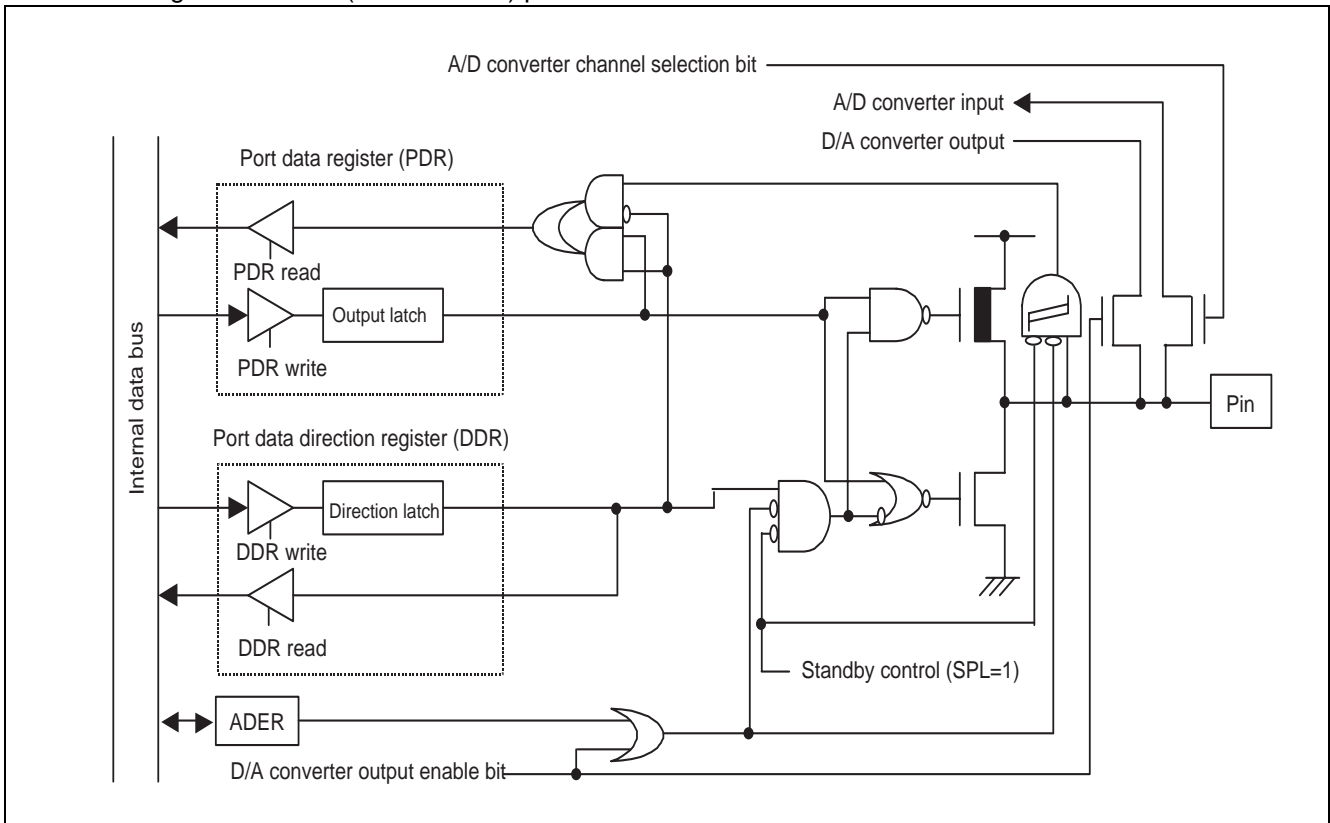

• Block diagram of P72 pin

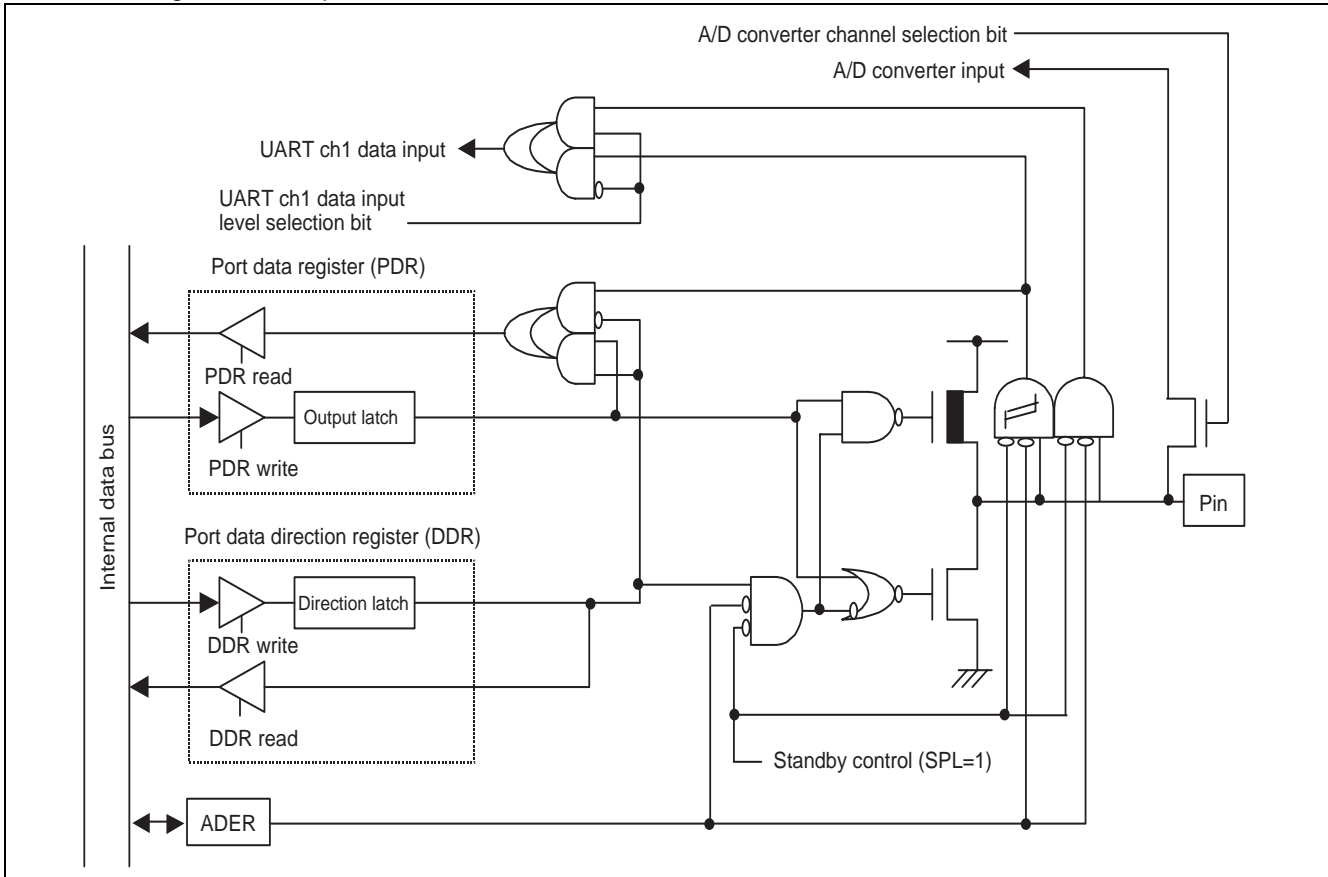

• Block diagram of Port 7(P73 and P74) pins

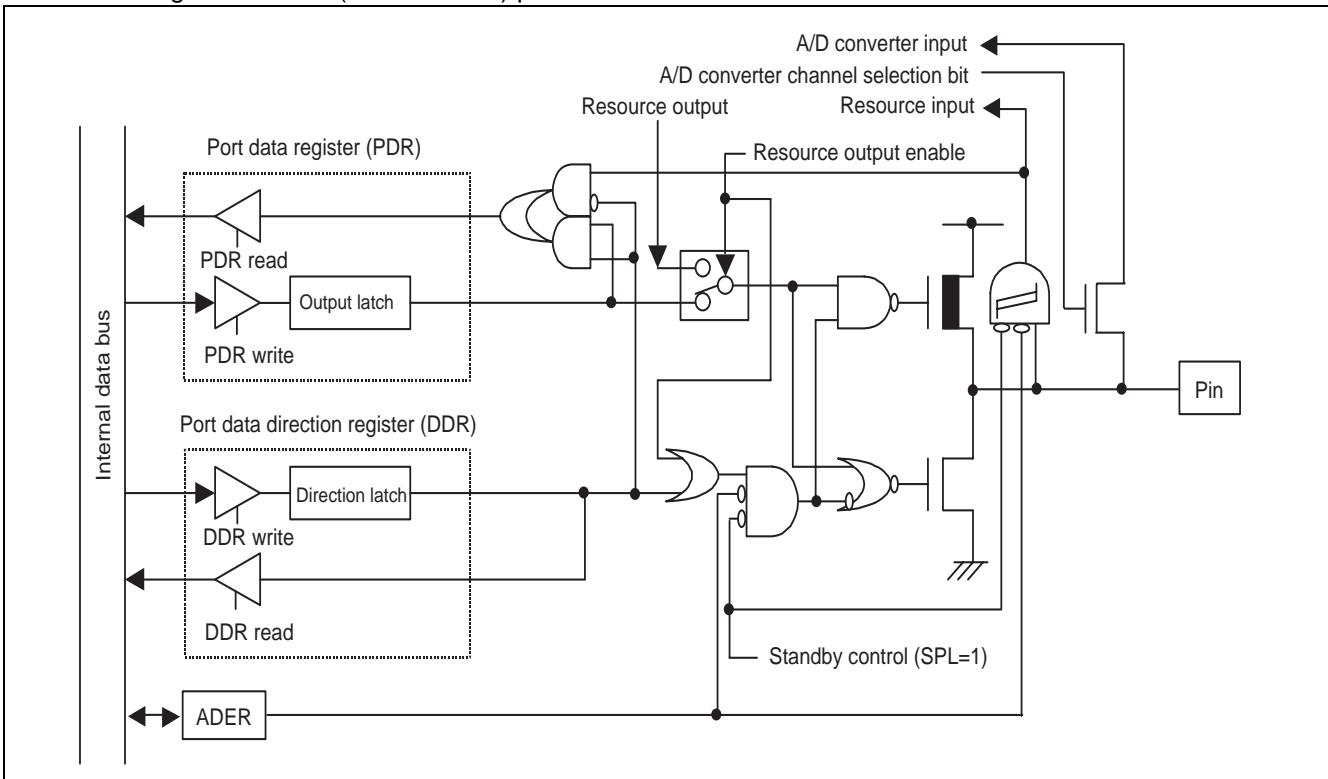





- Block diagram of Port 8 (P82 to P87) pins

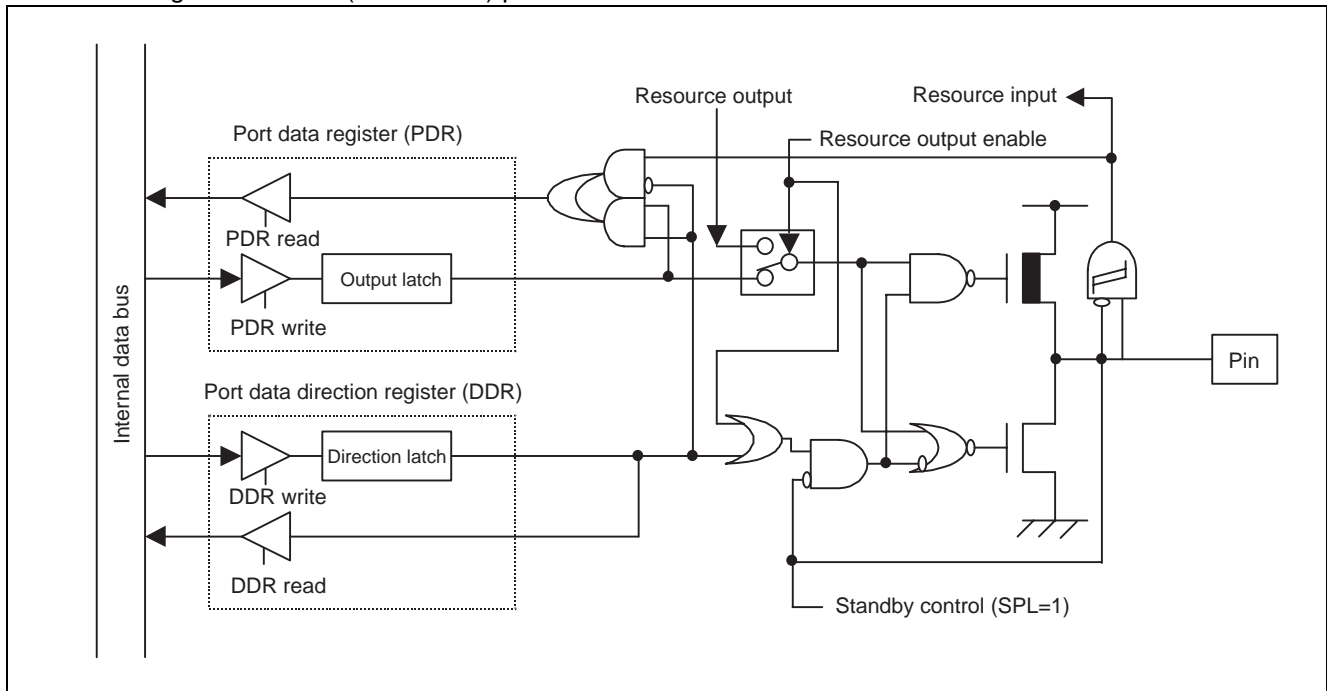

# MB90820 Series

## 3. Timebase Timer

The timebase timer is an 18-bit free-running counter (timebase counter) that counts up in synchronization with the internal count clock (divided by 1/2 of oscillation clock).

Features of timebase timer :

- Generates the interruption at counter-overflow
- Supports for EI<sup>2</sup>OS
- Interval timer function:  
Generates an interrupt at four different time intervals
- Clock supply function:  
Four different clock can be selected as watchdog timer's count clock  
Supply clock for oscillation stabilization

### (1) Register configuration

Timebase Timer Control Register									
	15	14	13	12	11	10	9	8	Bit number
Address: 0000A9 <sub>H</sub>	Reserved	—	—	TBIE	TBOF	TBR	TBC1	TBC0	TBTC
Read/write ⇨	R/W	—	—	R/W	R/W	W	R/W	R/W	
Initial value ⇨	1	X	X	0	0	1	0	0	

### (2) Block diagram

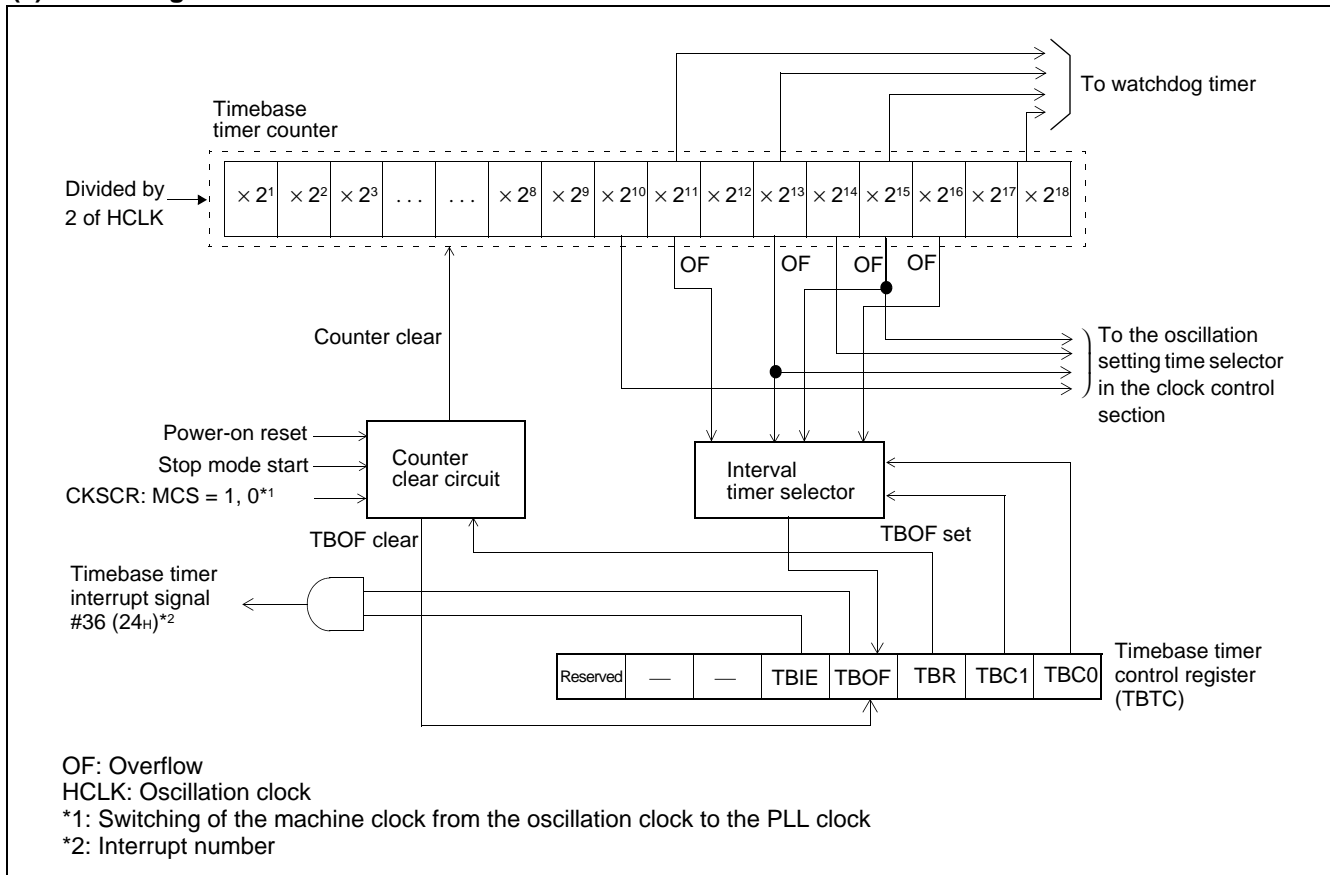

## 4. Watchdog Timer

The watchdog timer is a 2-bit counter that uses the timebase timer's supply clock as the count clock. After activation, if the watchdog timer is not cleared within a given period, the CPU will be reset.

- Features of watchdog timer :

Reset CPU at four different time intervals

Indicate the reset causes by status bits

### (1) Register configuration

Watchdog Timer Control Register								Bit	
	7	6	5	4	3	2	1	0	
Address: 0000A8H	PONR	—	WRST	ERST	SRST	WTE	WT1	WT0	WDTC
Read/write	R	—	R	R	R	W	W	W	
Initial value	X	X	X	X	X	1	1	1	

### (2) Block diagram

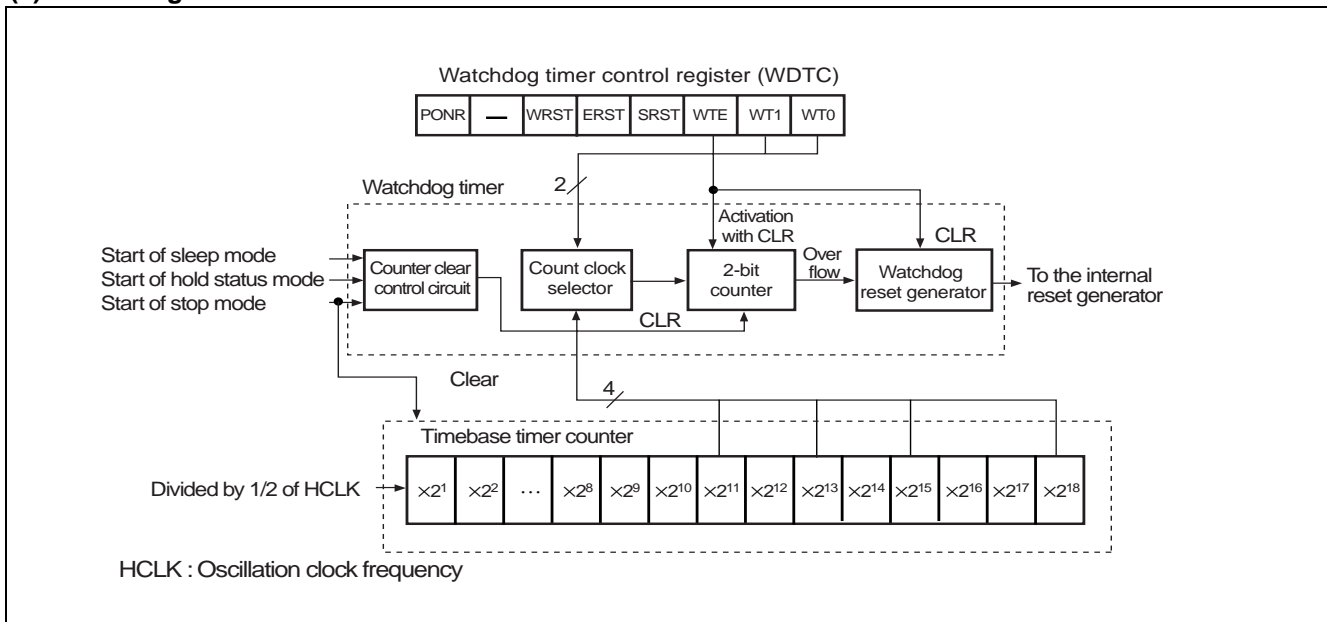

# MB90820 Series

## 5. 16-bit reload timer (× 2)

The 16-bit reload timer provides two operating mode, internal clock mode and event count mode. In each operating mode, the 16-bit down counter can be reloaded (reload mode) or stopped by underflow (one-shot mode).

Output pins TO1 and TO0 are able to output different waveform according to the counter operating mode. TO1 and TO0 toggles when counter underflows if counter is operated as reload mode. TO1 and TO0 output specified level (H or L) during counting if the counter is in one-shot mode.

Features of the 16-bit reload timer :

- Interrupt when timer underflows
- Supports for EI<sup>2</sup>OS
- Internal clock operating mode :  
Three internal count clocks can be selected.  
Counter can be activated by software or external trigger (signal at TIN1 and TIN0 pins).  
Counter can be reloaded or stopped when underflow after activated.
- Event count operating mode :  
Counter counts down one by one with specified edge at TIN1 and TIN0 pins.  
Counter can be reloaded or stopped when underflow.

### (1) Register configuration

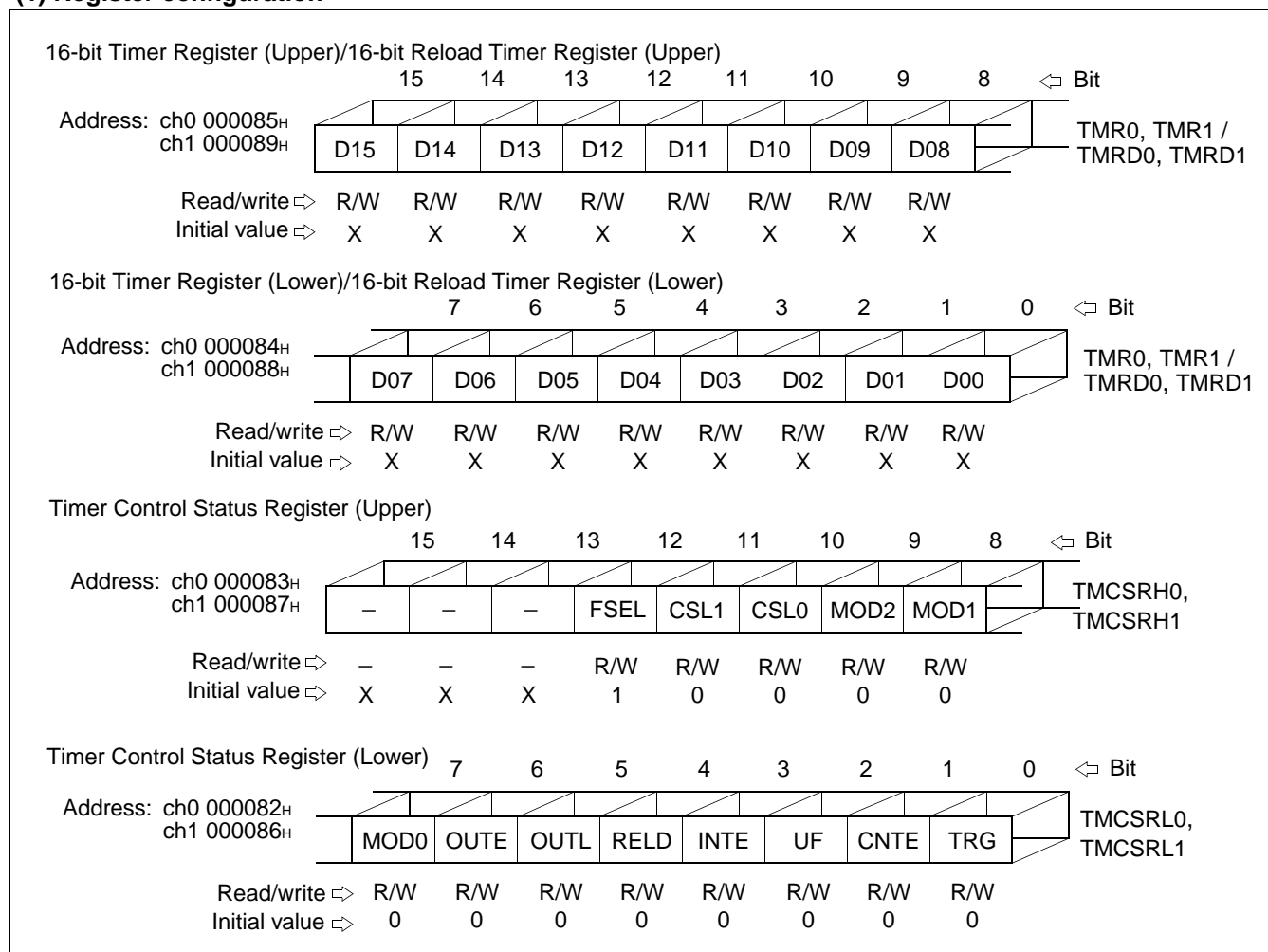

Note : Registers TMR0, TMR1/TMRD0, TMRD1 are word access only.



# MB90820 Series

## 6. 16-bit PPG Timer (× 3)

The 16-bit PPG timer consists of a 16-bit down counter, prescaler, 16-bit period setting register, 16-bit duty setting register, 16-bit control register and a PPG output pin. This module can be used to output pulses synchronized by software trigger or GATE signal from Multi-functional timer, refer to “7. Multi-functional Timer”.

Features of 16-bit PPG timer :

- Two operating mode : PWM and One-shot mode
- 8 types of counter operation clock ( $\phi$ ,  $\phi/2$ ,  $\phi/4$ ,  $\phi/8$ ,  $\phi/16$ ,  $\phi/32$ ,  $\phi/64$ ,  $\phi/128$ ) can be selected
- Interrupt is generated when trigger signal or counter borrow occurs, or when PPG output is changed
- Supports for EI<sup>2</sup>OS

### (1) Register configuration

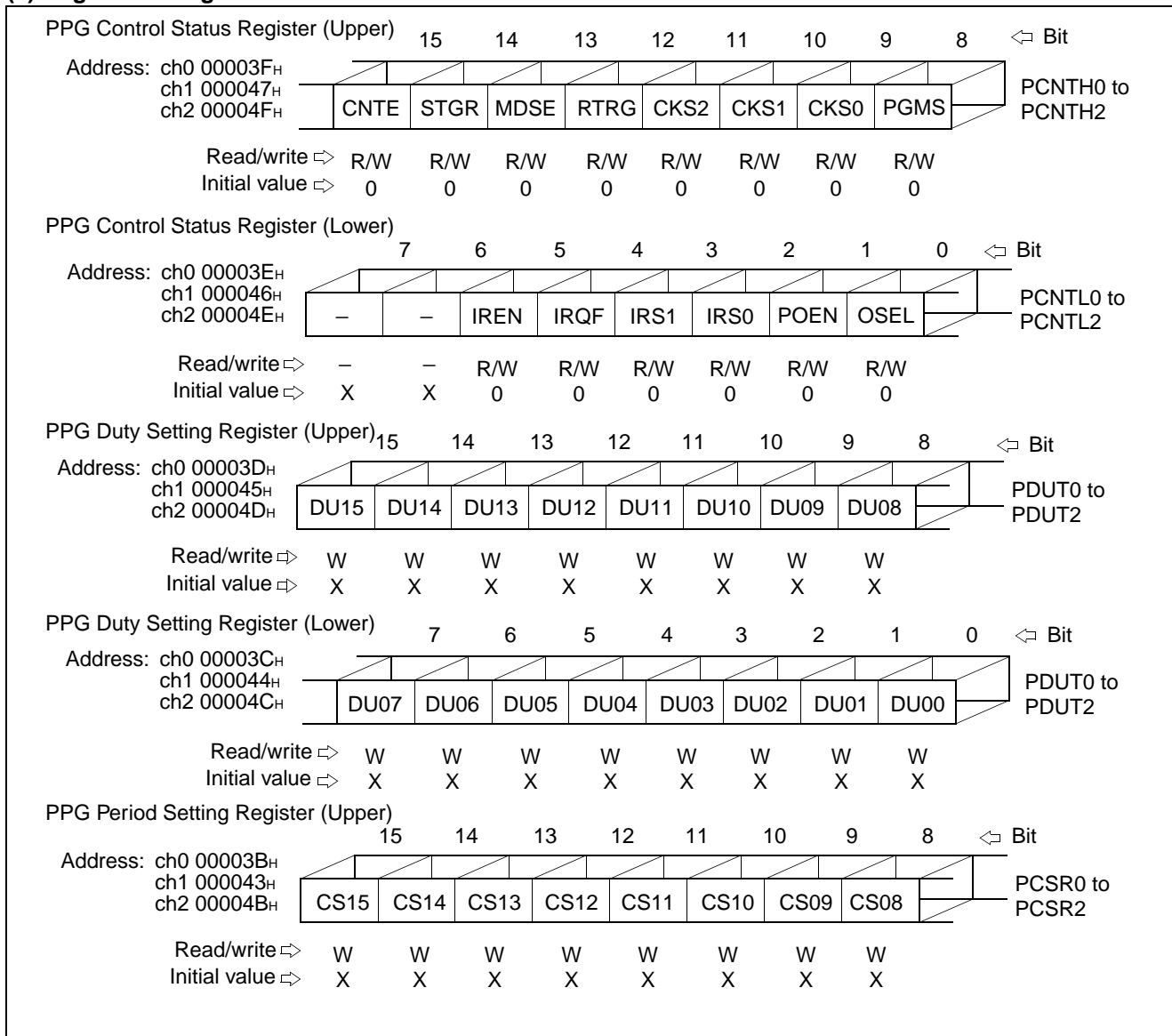

(Continued)

(Continued)

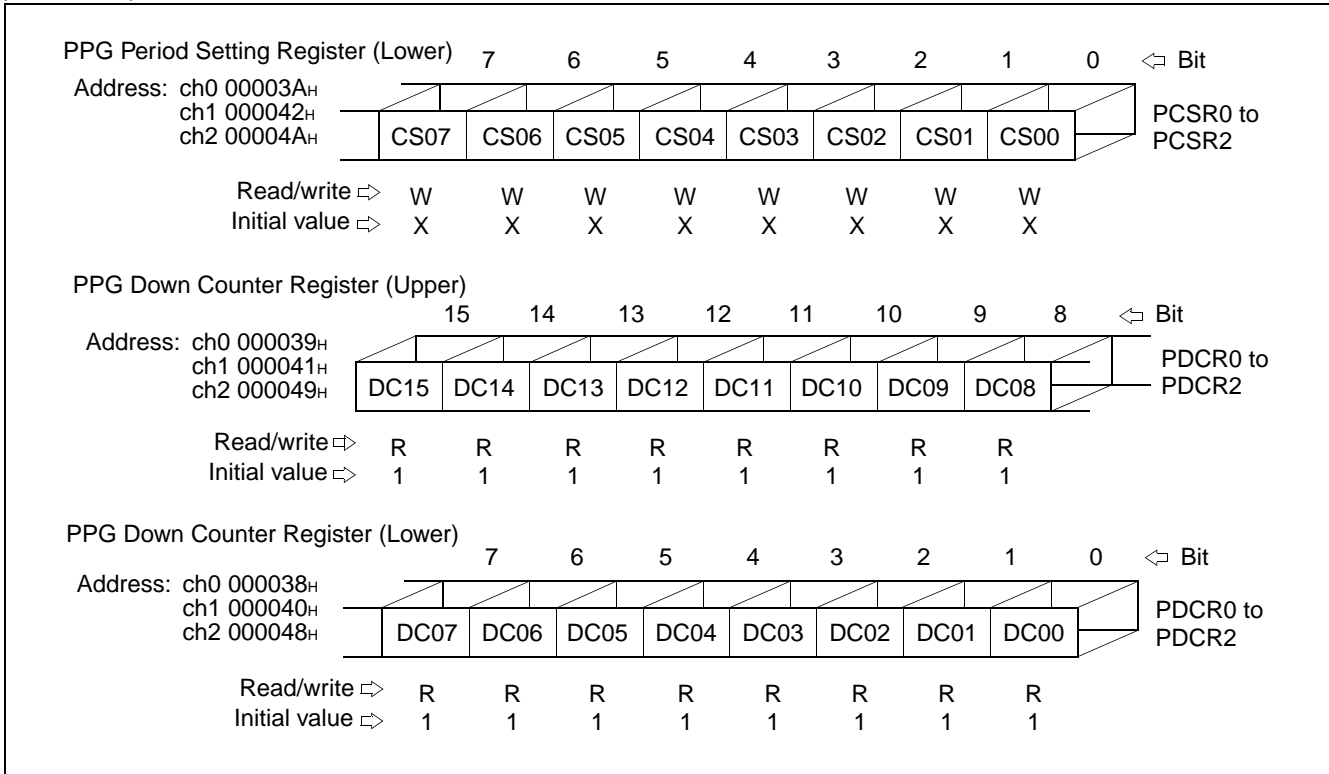

Note : Registers PDCR0 to PDCR2, PCSR0 to PCSR2 and PDUT0 to PDUT2 are word access only.

# MB90820 Series

## (2) Block diagram

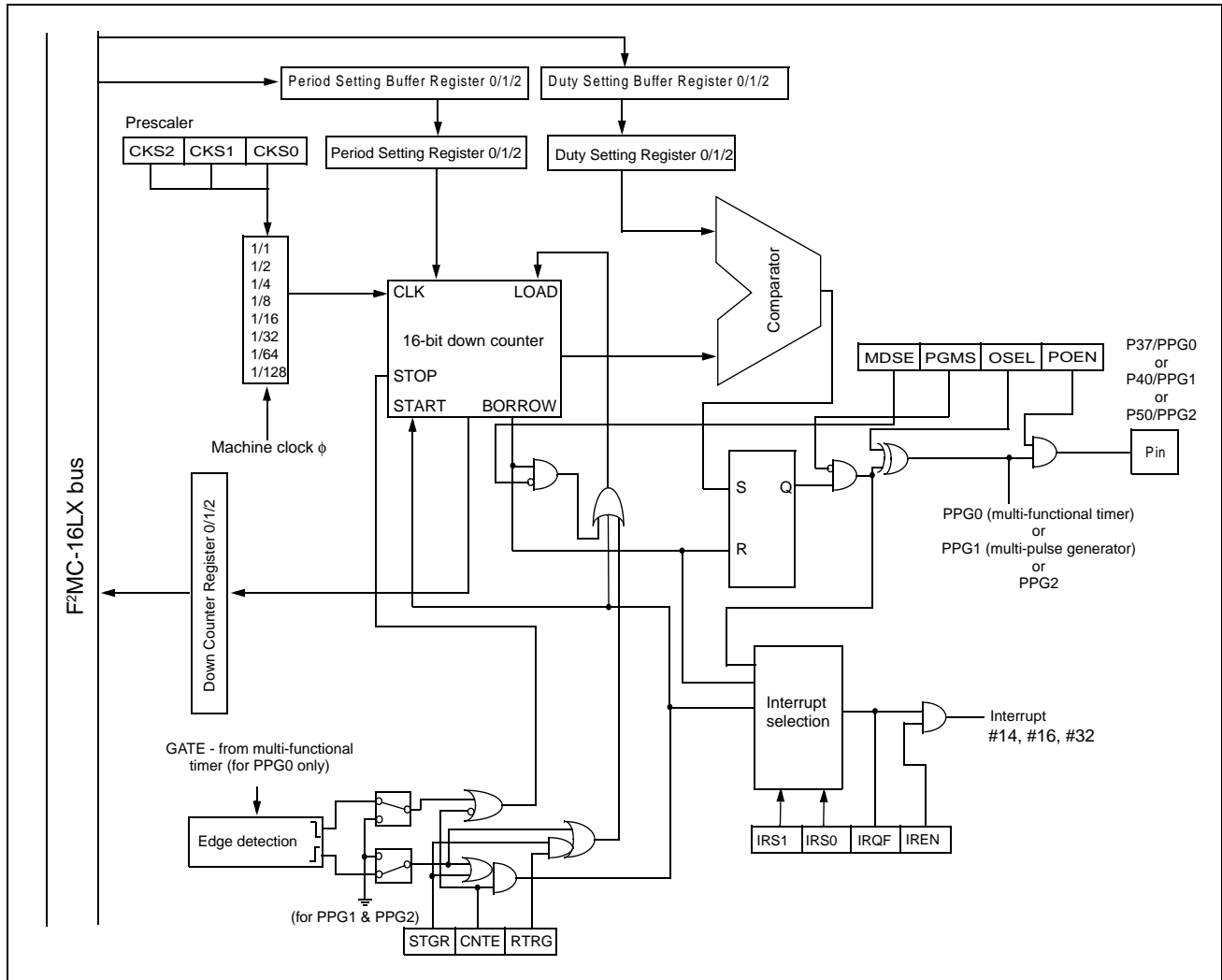



## 7. Multi-functional Timer

The 16-bit multi-functional timer module consists of one 16-bit free-running timer, four input capture circuits, six output comparators and one channel of 16-bit PPG timer. This module allows six independent waveforms generated by PPG timer or waveform generator to be outputted. With the 16-bit free-running timer and the input capture circuit, input pulse width and external clock period measurement can be done.

### (1) 16-bit free-running timer (1 channel)

- The 16-bit free-running timer consists of a 16-bit up counter, 16-bit up-down counter, timer control status register, 16-bit compare clear register (with buffer register) and a prescaler.
- 8 types of counter operation clock ( $\phi$ ,  $\phi/2$ ,  $\phi/4$ ,  $\phi/8$ ,  $\phi/16$ ,  $\phi/32$ ,  $\phi/64$ ,  $\phi/128$ ) can be selected. ( $\phi$  is the machine clock.)
- Two types of interrupt causes :
  - Compare clear interrupt is generated when there is a comparing match with compare clear register and 16-bit free-running timer.
  - Zero detection interrupt is generated while 16-bit free-running timer is detected as zero in count value.
- EI<sup>2</sup>OS supported.
- Compare-clear register buffer provided :  
The selectable buffer enables the 16-bit free-running timer update its compare-clear register automatically without stop the timer operation. User can read the next compare-clear value to the compare-clear register when the timer is running. The compare-clear register will be updated when the timer value is "0000H".
- Reset, software clear, compare match with compare clear register in up-count mode will reset the counter value to "0000H".
- Supply clock to output compare module :  
The prescaler output is acted as the count clock of the output compare.

### (2) Output compare module ( 6 channels)

- The output compare module consists of six 16-bit output compare registers (with selectable buffer register), compare output latch and compare control registers. An interrupt is generated and output level is inverted when the value of 16-bit free-running timer and output compare register are matched.
- 6 output compare registers can be operated independently.
- Output pins and interrupt flag are corresponding to each output compare register.
- 2 output compare registers can be paired to control the output pins.
- Inverts output pins by using 2 output compare registers together.
- Setting the initial value for each output pin is possible.
- Interrupt is generated when there is a comparing match with output compare register and 16-bit free-running timer.
- EI<sup>2</sup>OS supported.

### (3) Input capture module (4 channels)

Input capture consists of 4 independent external input pins, the corresponding input capture data register and input capture control status register. By detecting any edge of the input signal from the external pin, the value of the 16-bit free-running timer can be stored in the capture register and an interrupt is generated simultaneously.

- Operations synchronized with the 16-bit free-running timer's count clock.
- 3 types of trigger edge (rising edge, falling edge and both edge) of the external input signal can be selected and there is indication bit to show the trigger edge is rising or falling.
- 4 input captures can be operated independently.
- Two independent interrupts are generated when detecting a valid edge from external input.
- EI<sup>2</sup>OS supported.

# MB90820 Series

## (4) 16-bit PPG timer (1 channel)

The 16-bit PPG timer 0 is used to provide a PPG signal for waveform generator. (See section “6. 16-bit PPG Timer (× 3)”).

## (5) Waveform generator module

The waveform generator consists of three 16-bit timer registers, three 16-bit timer control registers and a waveform control register.

With waveform generator, it is possible to generate real time output, 16-bit PPG waveform output, non-overlap 3-phase waveform output for inverter control and DC chopper waveform output.

- It is possible to generate a non-overlap waveform output based on dead-time of 16-bit timer. (Dead-time timer function)
- It is possible to generate a non-overlap waveform output when realtime output is operated in 2-channel mode. (Dead-time timer function)
- By detecting realtime output compare match, GATE signal of the PPG timer operation will be generated to start or stop PPG timer operation. (GATE function)
- When a match is detected by real time output compare, the 16-bit timer is activated. The PPG timer can be started or stopped easily by generating a GATE signal for PPG operation until the 16-bit timer stops. (GATE function)
- Force to stop output waveform using DTTI pin input.
- Interrupt is generated when DTTI active or 16-bit timer underflow.
- EI<sup>2</sup>OS is supported.

## (6) Register configuration

- 16-bit free-running timer registers

Timer Control Status Register (Upper)									
	15	14	13	12	11	10	9	8	⇐ Bit
Address: 00005F <sub>H</sub>	ECKE	IRQZF	IRQZE	MSI2	MSI1	MSI0	ICLR	ICRE	TCCSH
Read/write ⇐	R/W	R/W	R/W	R/W	R/W	R/W	R/W	R/W	
Initial value ⇐	0	0	0	0	0	0	0	0	
Timer Control Status Register (Lower)									
	7	6	5	4	3	2	1	0	⇐ Bit
Address: 00005E <sub>H</sub>	–	BFE	STOP	MODE	SCLR	CLK2	CLK1	CLK0	TCCSL
Read/write ⇐	–	R/W	R/W	R/W	R/W	R/W	R/W	R/W	
Initial value ⇐	X	0	1	0	0	0	0	0	
Timer Data Register (Upper)									
	15	14	13	12	11	10	9	8	⇐ Bit
Address: 00005D <sub>H</sub>	T15	T14	T13	T12	T11	T10	T09	T08	TCDT
Read/write ⇐	R/W	R/W	R/W	R/W	R/W	R/W	R/W	R/W	
Initial value ⇐	0	0	0	0	0	0	0	0	
Timer Data Register (Lower)									
	7	6	5	4	3	2	1	0	⇐ Bit
Address: 00005C <sub>H</sub>	T07	T06	T05	T04	T03	T02	T01	T00	TCDT
Read/write ⇐	R/W	R/W	R/W	R/W	R/W	R/W	R/W	R/W	
Initial value ⇐	0	0	0	0	0	0	0	0	

(Continued)

(Continued)

Compare Clear Buffer Register / Compare Clear Register (Upper)									
	15	14	13	12	11	10	9	8	Bit
Address: 00005B <sub>H</sub>	CL15	CL14	CL13	CL12	CL11	CL10	CL09	CL08	CPCLR <sub>B</sub> /CPCLR
Read/write ⇨	R/W	R/W	R/W	R/W	R/W	R/W	R/W	R/W	
Initial value ⇨	1	1	1	1	1	1	1	1	

Compare Clear Buffer Register / Compare Clear Register (Lower)									
	7	6	5	4	3	2	1	0	Bit
Address: 00005A <sub>H</sub>	CL07	CL06	CL05	CL04	CL03	CL02	CL01	CL00	CPCLR <sub>B</sub> /CPCLR
Read/write ⇨	R/W	R/W	R/W	R/W	R/W	R/W	R/W	R/W	
Initial value ⇨	1	1	1	1	1	1	1	1	

Note : Registers TCDT, CPCLR<sub>B</sub>/CPCLR are word access only.

• Output compare registers

Compare Control Register (Upper)									
	15	14	13	12	11	10	9	8	Bit
Address: ch1 00007D <sub>H</sub> ch3 00007F <sub>H</sub> ch5 000081 <sub>H</sub>	-	BTS1	BTS0	CMOD	OTE1	OTE0	OTD1	OTD0	OCS1/3/5
Read/write ⇨	-	R/W	R/W	R/W	R/W	R/W	R/W	R/W	
Initial value ⇨	X	1	1	0	0	0	0	0	

Compare Control Register (Lower)									
	7	6	5	4	3	2	1	0	Bit
Address: ch0 00007C <sub>H</sub> ch2 00007E <sub>H</sub> ch4 000080 <sub>H</sub>	IOP1	IOP0	IOE1	IOE0	BUF1	BUF0	CST1	CST0	OCS0/2/4
Read/write ⇨	R/W	R/W	R/W	R/W	R/W	R/W	R/W	R/W	
Initial value ⇨	0	0	0	0	1	1	0	0	

Output Compare Buffer Register / Output Compare Register (Upper)									
	15	14	13	12	11	10	9	8	Bit
Address: ch0 000071 <sub>H</sub> ch1 000073 <sub>H</sub> ch2 000075 <sub>H</sub> ch3 000077 <sub>H</sub> ch4 000079 <sub>H</sub> ch5 00007B <sub>H</sub>	OP15	OP14	OP13	OP12	OP11	OP10	OP09	OP08	OCCPB0 to OCCPB5/ OCCP0 to OCCP5
Read/write ⇨	R/W	R/W	R/W	R/W	R/W	R/W	R/W	R/W	
Initial value ⇨	X	X	X	X	X	X	X	X	

Output Compare Buffer Register / Output Compare Register (Lower)									
	7	6	5	4	3	2	1	0	Bit
Address: ch0 000070 <sub>H</sub> ch1 000072 <sub>H</sub> ch2 000074 <sub>H</sub> ch3 000076 <sub>H</sub> ch4 000078 <sub>H</sub> ch5 00007A <sub>H</sub>	OP07	OP06	OP05	OP04	OP03	OP02	OP01	OP00	OCCPB0 to OCCPB5/ OCCP0 to OCCP5
Read/write ⇨	R/W	R/W	R/W	R/W	R/W	R/W	R/W	R/W	
Initial value ⇨	X	X	X	X	X	X	X	X	

Note : Register OCCPB0 to OCCPB5 and OCCP0 to OCCP5 are word access only.

# MB90820 Series

## • Input capture registers

### Input Capture Control Status Register (2/3) (Upper)

	15	14	13	12	11	10	9	8	Bit
Address: 00006B <sub>H</sub>	–	–	–	–	–	–	IEI3	IEI2	ICSH23
Read/write ⇨	–	–	–	–	–	–	R	R	
Initial value ⇨	X	X	X	X	X	X	0	0	

### Input Capture Control Status Register (2/3) (Lower)

	7	6	5	4	3	2	1	0	Bit
Address: 00006A <sub>H</sub>	ICP3	ICP2	ICE3	ICE2	EG31	EG30	EG21	EG20	ICSL23
Read/write ⇨	R/W	R/W	R/W	R/W	R/W	R/W	R/W	R/W	
Initial value ⇨	0	0	0	0	0	0	0	0	

### PPG output control/ Input Capture Control Status Register (0/1) (Upper)

	15	14	13	12	11	10	9	8	Bit
Address: 000069 <sub>H</sub>	PGEN5	PGEN4	PGEN3	PGEN2	PGEN1	PGEN0	IEI1	IEI0	PICSH01
Read/write ⇨	R/W	R/W	R/W	R/W	R/W	R/W	R	R	
Initial value ⇨	0	0	0	0	0	0	0	0	

### Input Capture Control Status Register (0/1) (Lower)

	7	6	5	4	3	2	1	0	Bit
Address: 000068 <sub>H</sub>	ICP1	ICP0	ICE1	ICE0	EG11	EG10	EG01	EG00	PICSL01
Read/write ⇨	R/W	R/W	R/W	R/W	R/W	R/W	R/W	R/W	
Initial value ⇨	0	0	0	0	0	0	0	0	

### Input Capture Data Register (Upper)

Address:	15	14	13	12	11	10	9	8	Bit
ch0 000061 <sub>H</sub>	CP15	CP14	CP13	CP12	CP11	CP10	CP09	CP08	IPCP0 to IPCP3
ch1 000063 <sub>H</sub>									
ch2 000065 <sub>H</sub>									
ch3 000067 <sub>H</sub>									
Read/write ⇨	R	R	R	R	R	R	R	R	
Initial value ⇨	X	X	X	X	X	X	X	X	

### Input Capture Data Register (Lower)

Address:	7	6	5	4	3	2	1	0	Bit
ch0 000060 <sub>H</sub>	CP07	CP06	CP05	CP04	CP03	CP02	CP01	CP00	IPCP0 to IPCP3
ch1 000062 <sub>H</sub>									
ch2 000064 <sub>H</sub>									
ch3 000066 <sub>H</sub>									
Read/write ⇨	R	R	R	R	R	R	R	R	
Initial value ⇨	X	X	X	X	X	X	X	X	

Note : Registers IPCP0 to IPCP3 are word access only.

• Waveform generator registers

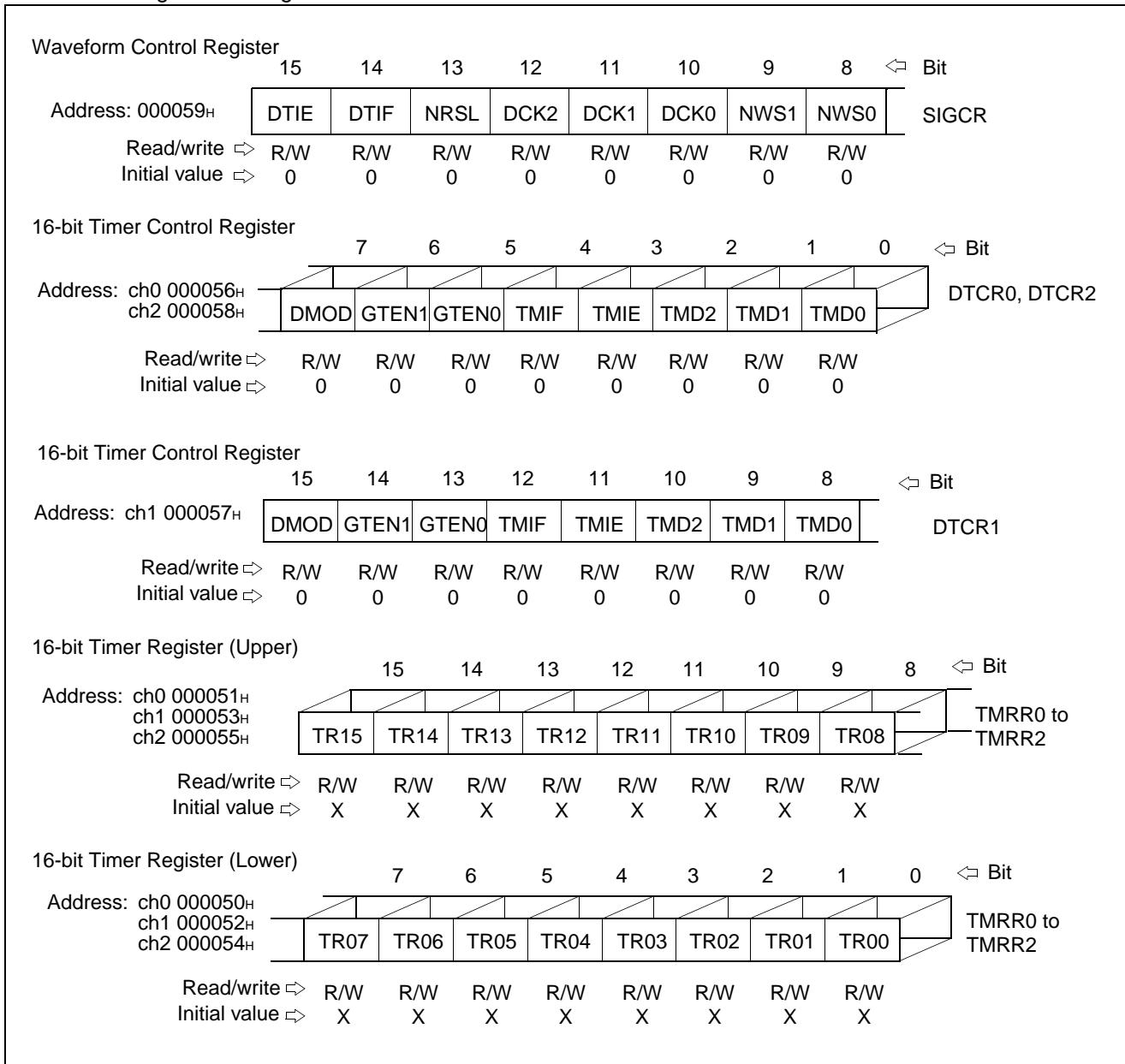

Note : Registers TMRR0 to TMRR2 are word access only.

# MB90820 Series

## • MCU to 3-phase Motor Interface Circuit

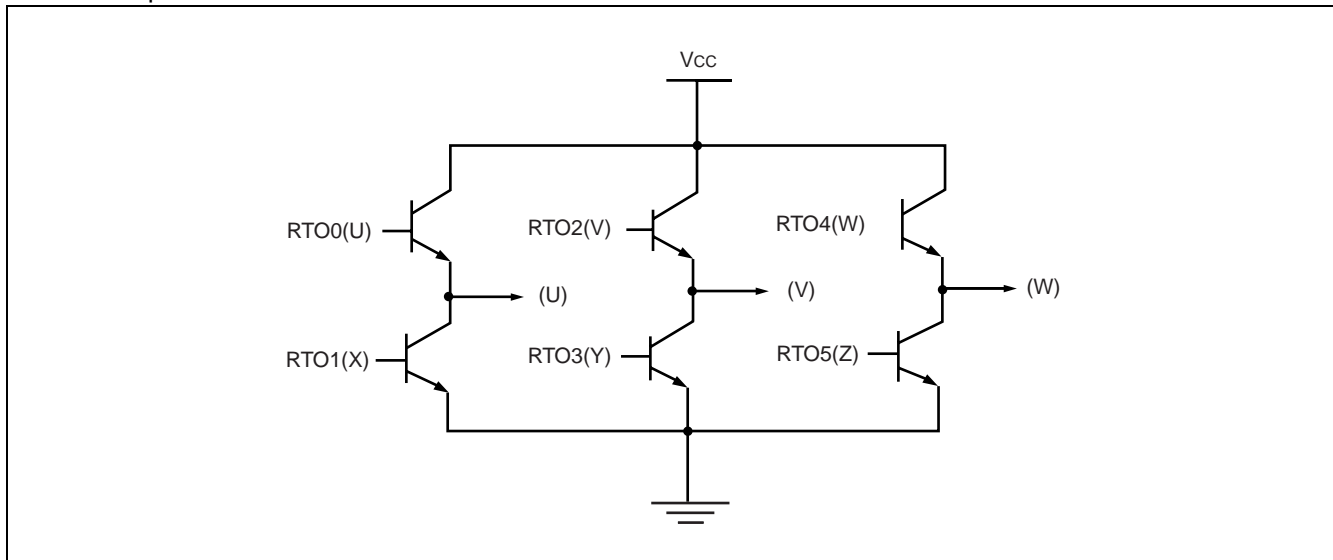

RTO0 (U) , RTO2 (V) , RTO4 (W) are called "UPPER ARM".  
RTO1 (X) , RTO3 (Y) , RTO5 (Z) are called "LOWER ARM".

RTO0 (U) and RTO1 (X) are called "non-overlapping output pair".  
RTO2 (V) and RTO3 (Y) are called "non-overlapping output pair".  
RTO4 (W) and RTO5 (Z) are called "non-overlapping output pair".

(U) , (V) , (W) are the 3-phase coil connection.

## • 3-phase Motor Coil Connection Circuit

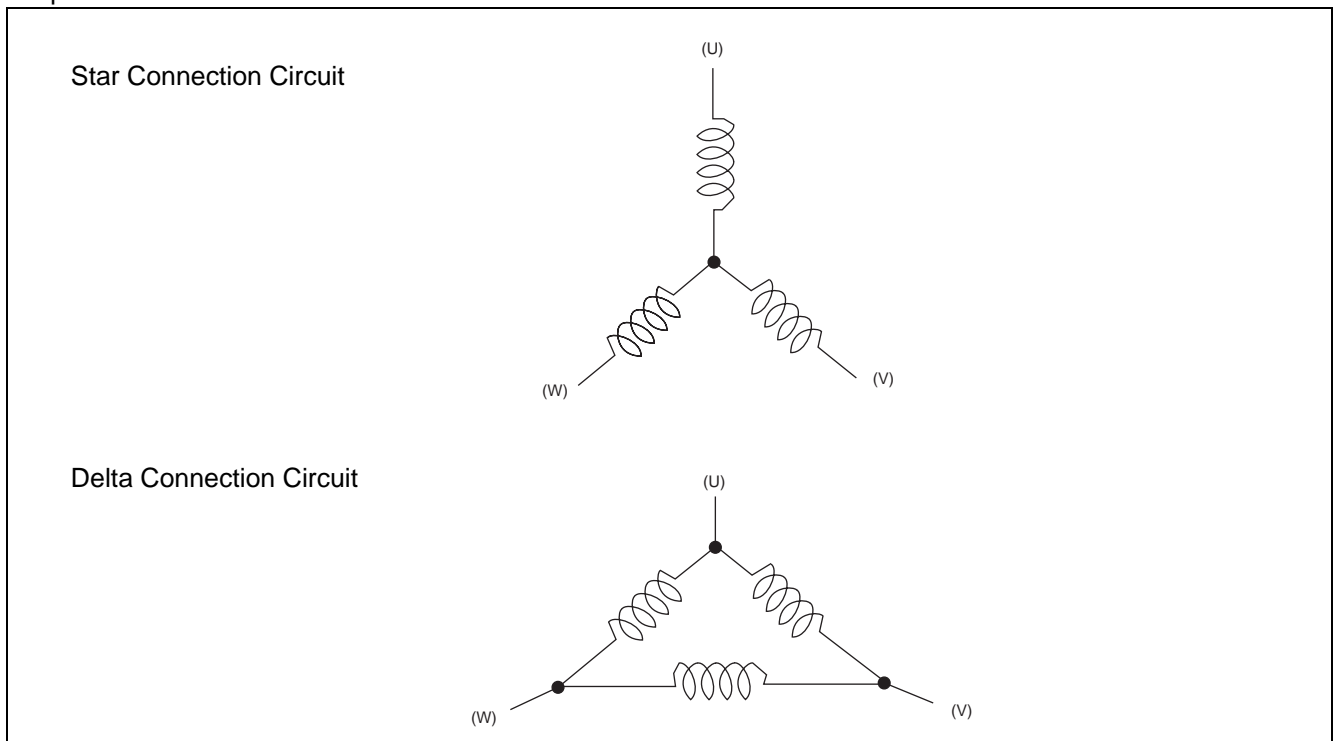

## (7) Block diagram

- Block diagram of Multi-functional timer

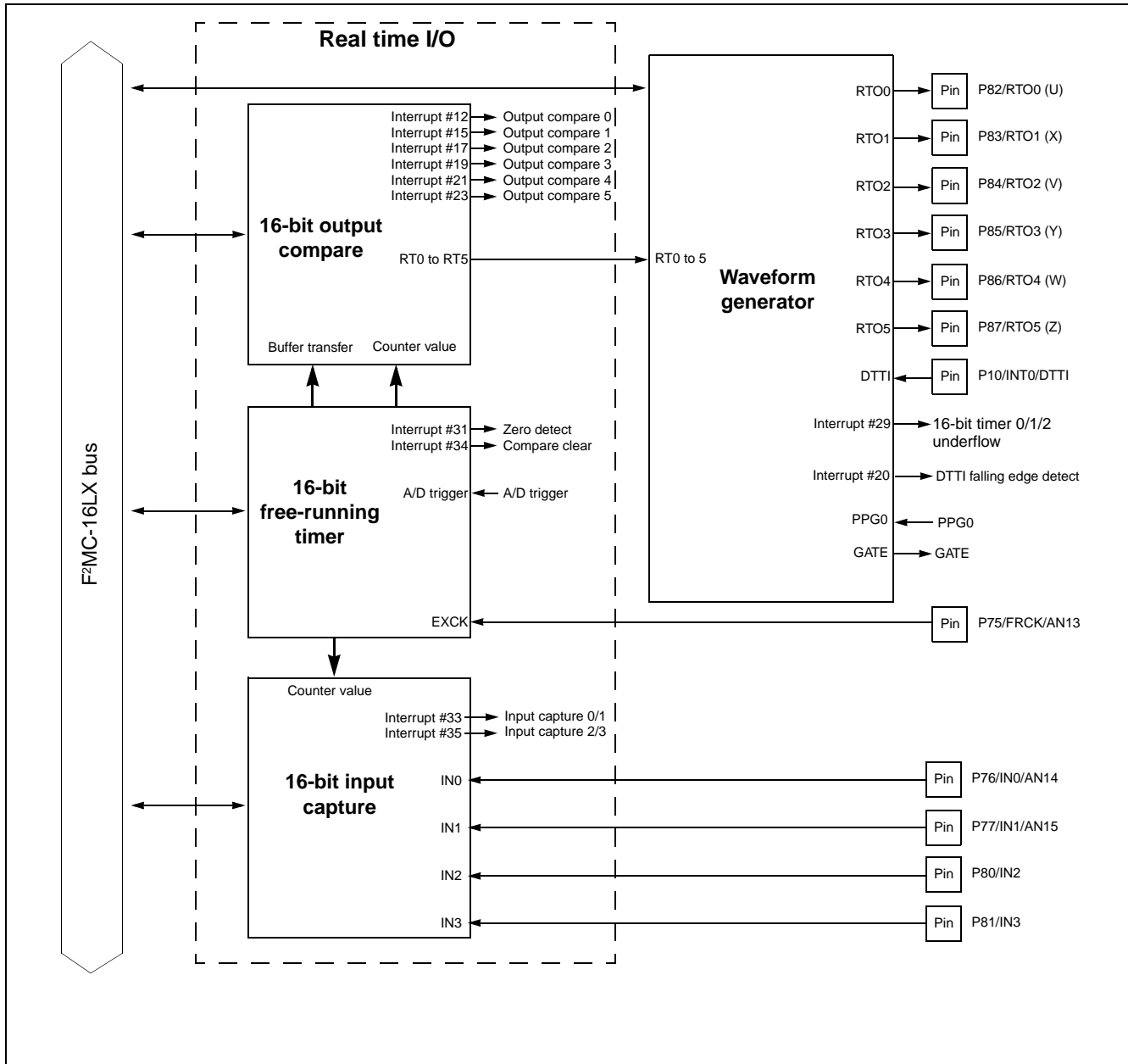

Interrupt #12	Output compare 0	Interrupt #31	Zero detect
Interrupt #15	Output compare 1	Interrupt #34	Compare clear
Interrupt #17	Output compare 2	Interrupt #33	input compare 0/1
Interrupt #19	Output compare 3	Interrupt #35	input compare 2/3
Interrupt #21	Output compare 4		
Interrupt #23	Output compare 5		

# MB90820 Series

- Block diagram of 16-bit free-running timer

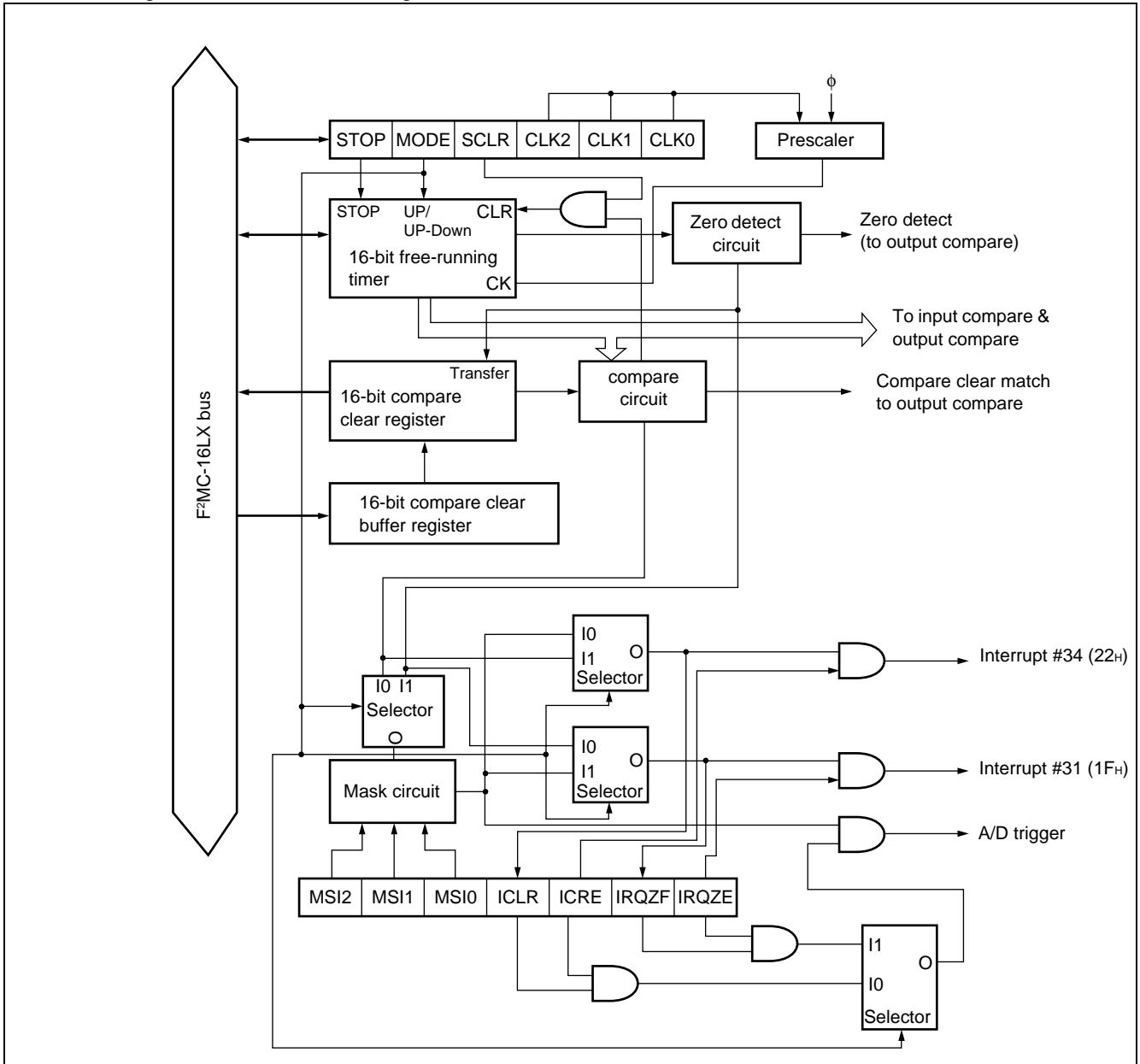



• Block diagram of 16-bit output compare

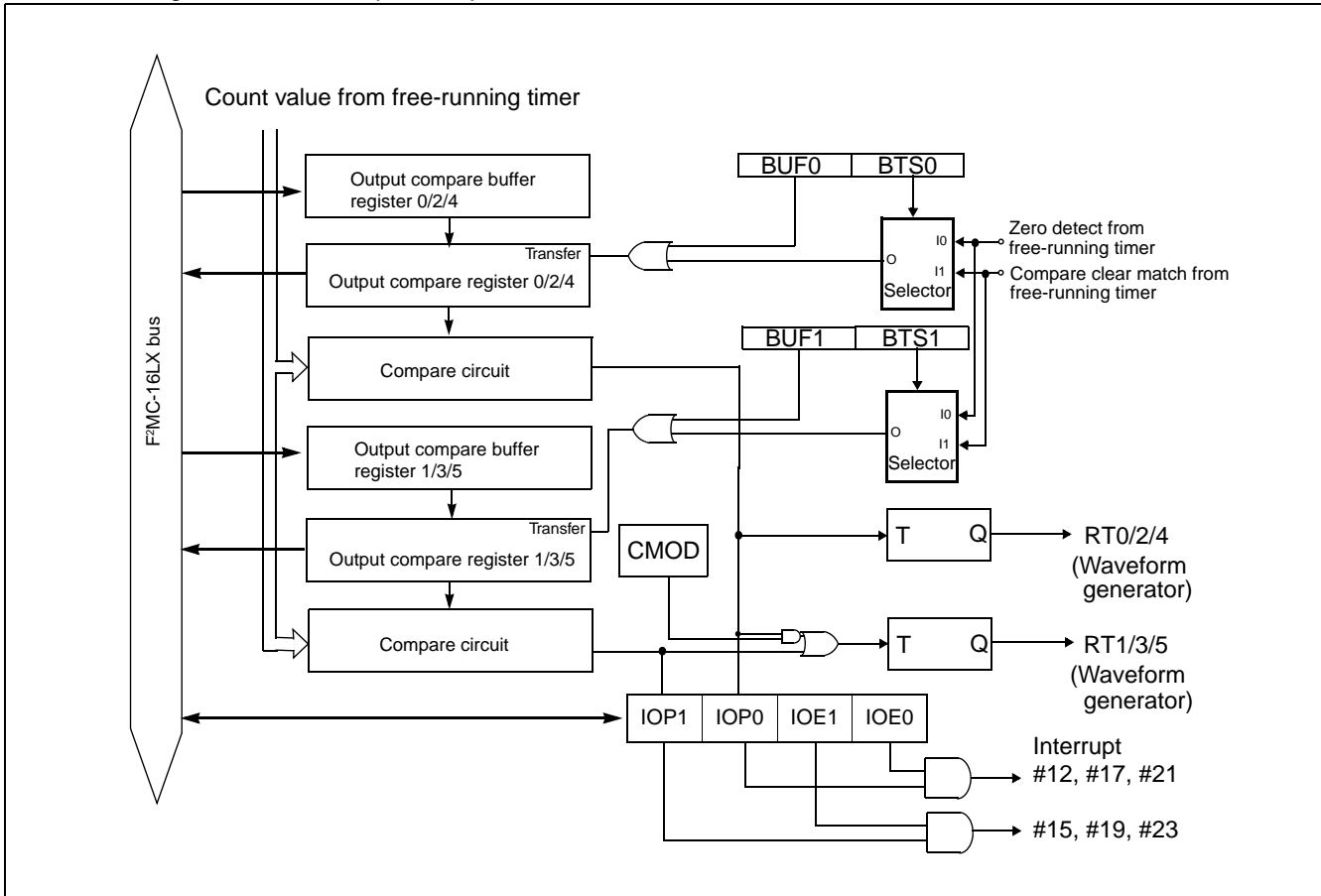

• Block diagram of 16-bit input capture

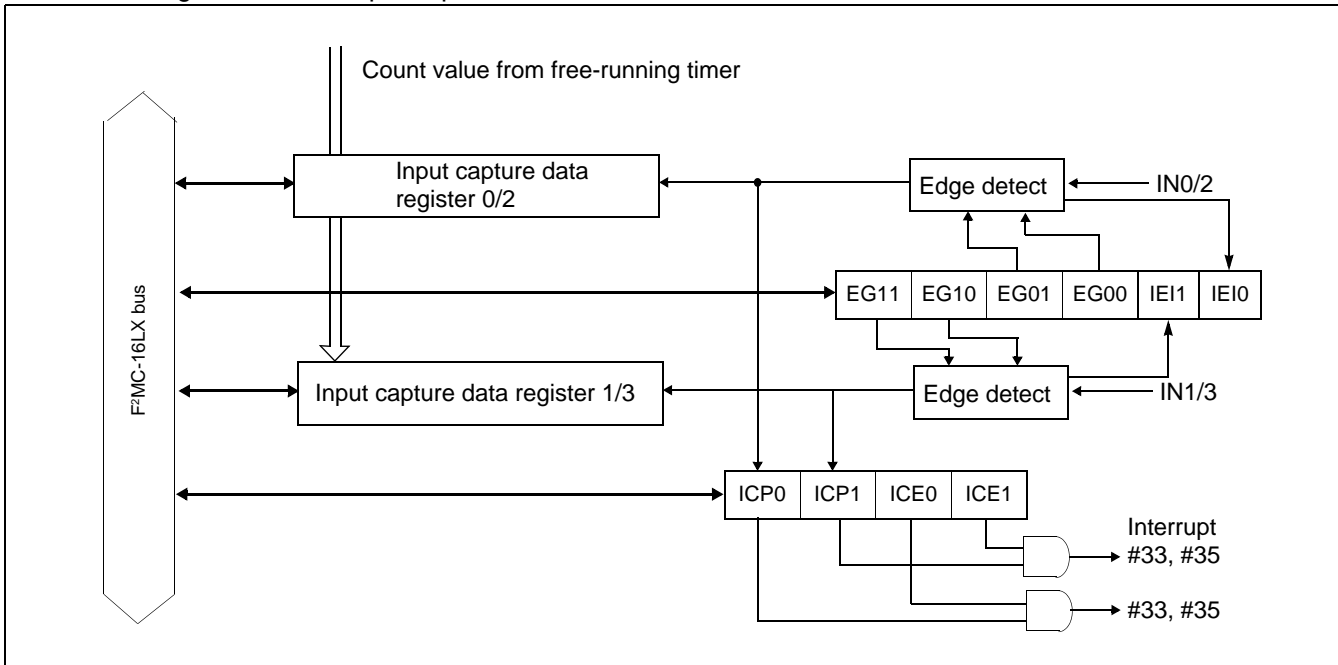

# MB90820 Series

• Block diagram of waveform generator

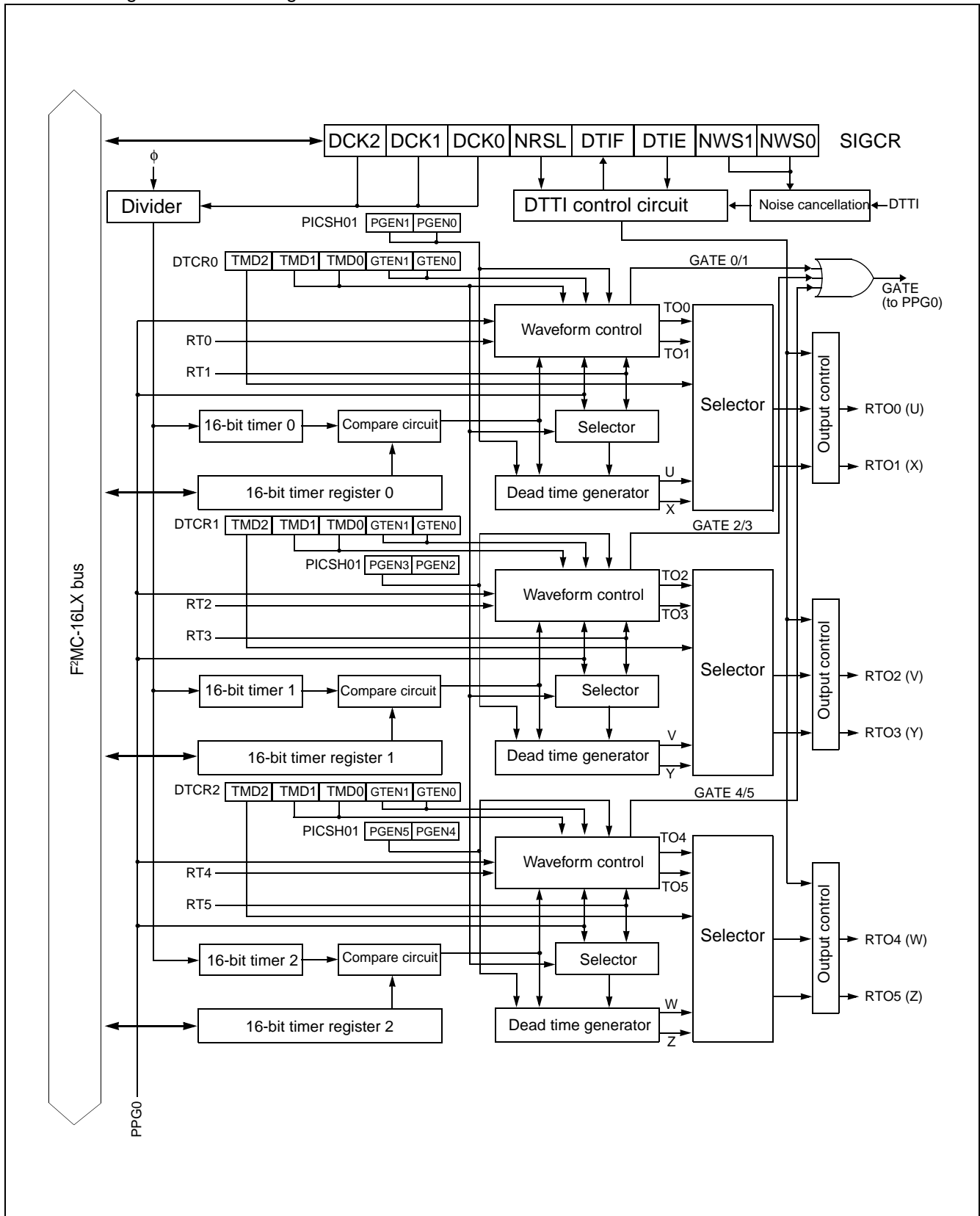

## 8. PWC Timer ( × 2)

The PWC (pulse width count) timer is a 16-bit multi-functional up counter with reload timer functions and input signal pulse width count functions.

The PWC timer consists of a 16-bit counter, an input pulse divider, a division ratio control register, a count input pin, a pulse output pin, and a 16-bit control register.

The PWC timer has the following features:

- Interruption is generated when timer overflow or end of PWC measurement.
- EI<sup>2</sup>OS is supported.
- Timer functions :
  - Generates an interrupt request at set time intervals.
  - Outputs pulse signals synchronized with the timer cycle.
  - Selects the counter clock from three internal clocks.
- Pulse-width count functions:
  - Counts the time between external pulse input events.
  - Selects the counter clock from three internal clocks.
  - Count mode:
    - H pulse width (rising edge to falling edge) / L pulse width (falling edge to rising edge)
    - Rising-edge cycle (rising edge to falling edge) / Falling-edge cycle (falling edge to rising edge)
    - Count between edges (rising or falling edge to falling or rising edge)

Capable of counting cycles by dividing input pulses by 2<sup>2</sup>, 2<sup>4</sup>, 2<sup>6</sup>, 2<sup>8</sup> using an 8-bit input divider.

Generates an interrupt request upon the completion of count operation.

Selects single or consecutive count operation.

### (1) Register configuration

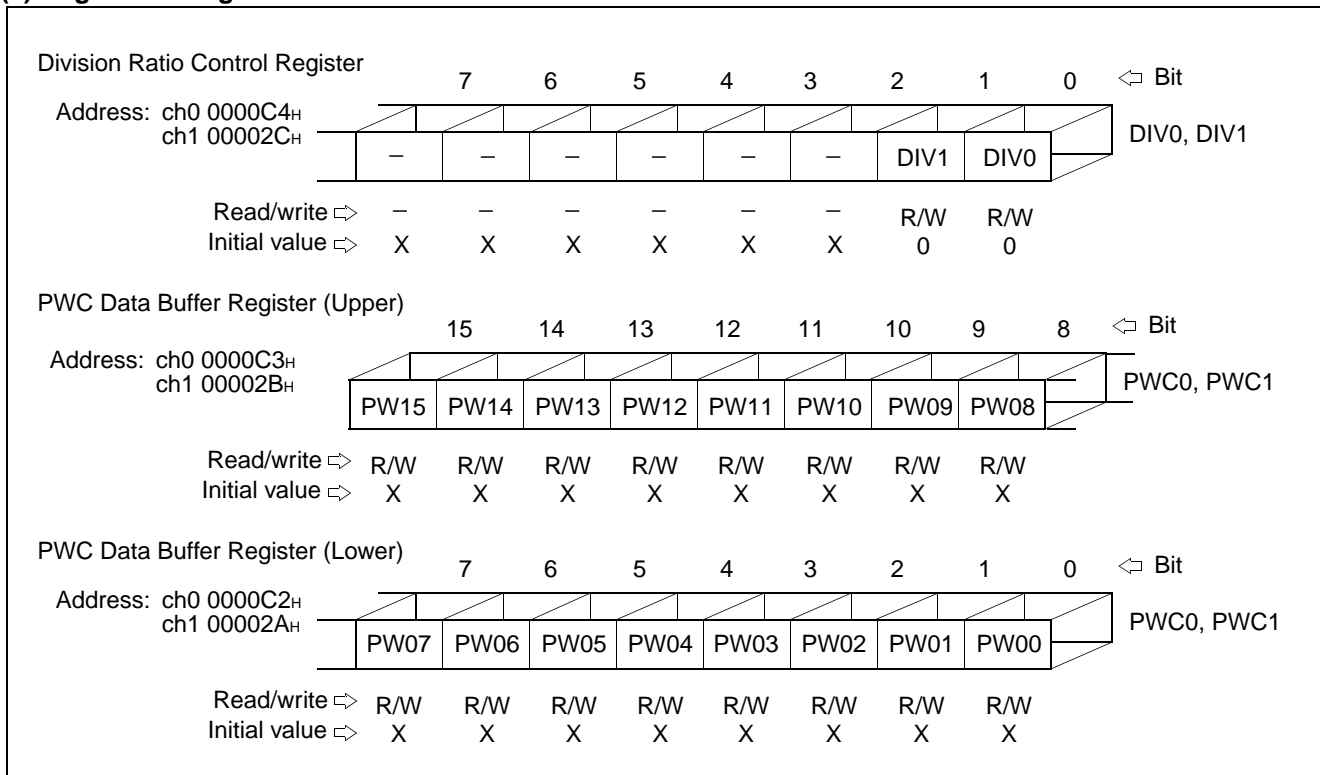

Note : Registers PWC0, PWC1 are word access only.

(Continued)



## 9. UART ( × 2)

The UART is a serial I/O port for asynchronous (start-stop) communication or clock-synchronous communication. The UART has the following features :

- Full-duplex double buffering
- Capable of asynchronous (start-stop bit) and CLK-synchronous communications
- Support for the multiprocessor mode
- Various method of baud rate generation :
  - External clock input possible
  - Internal clock (a clock supplied from 16-bit reload timer can be used.)
  - Embedded dedicated baud rate generator

Operation	Baud rate
Asynchronous	31250/9615/4808/2404/1202 bps
CLK synchronous	2 M/1 M/500 K/250 K/125 K/62.5K bps

Note : Assuming internal machine clock frequencies of 6 MHz, 8 MHz, 10 MHz, 12 MHz, and 16 MHz.

- Error detection functions (parity, framing, overrun)
- NRZ (Non Return to Zero) signal format
- Interrupt request :
  - Receive interrupt (receive complete, receive error detection)
  - Transmit interrupt (transmission complete)
  - Transmit / receive conforms to extended intelligent I/O service (EI<sup>2</sup>OS).

# MB90820 Series

## (1) Register configuration

### Serial Status Register

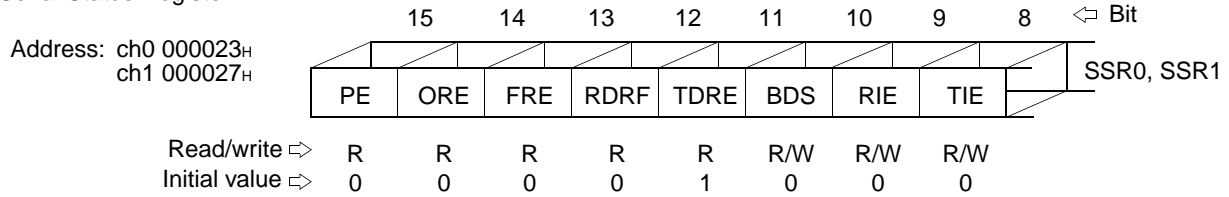

### Serial Input Data Register / Serial Output Data Register

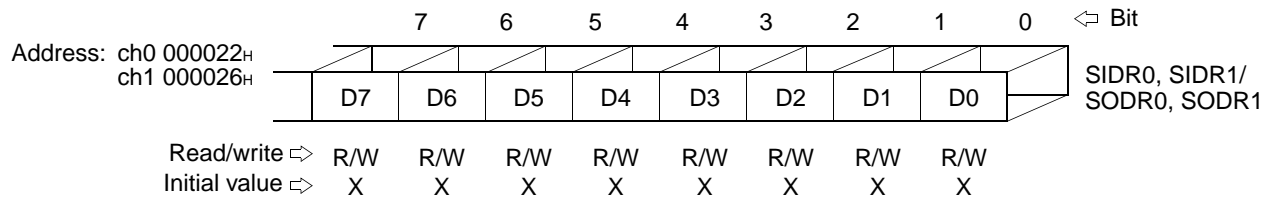

### Serial Control Register

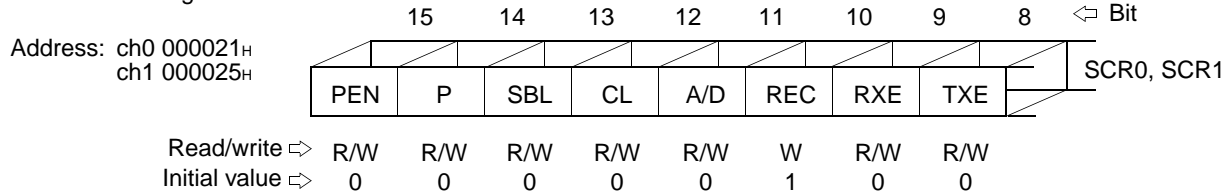

### Serial Mode Register

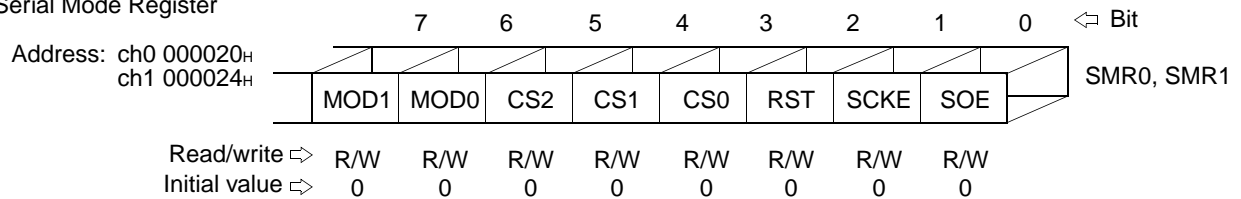

### Clock Division Control Register

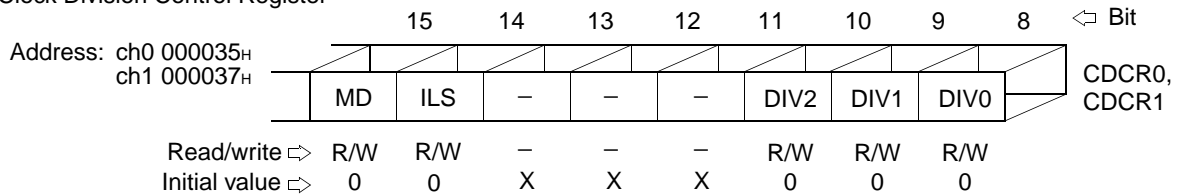

## (2) Block diagram

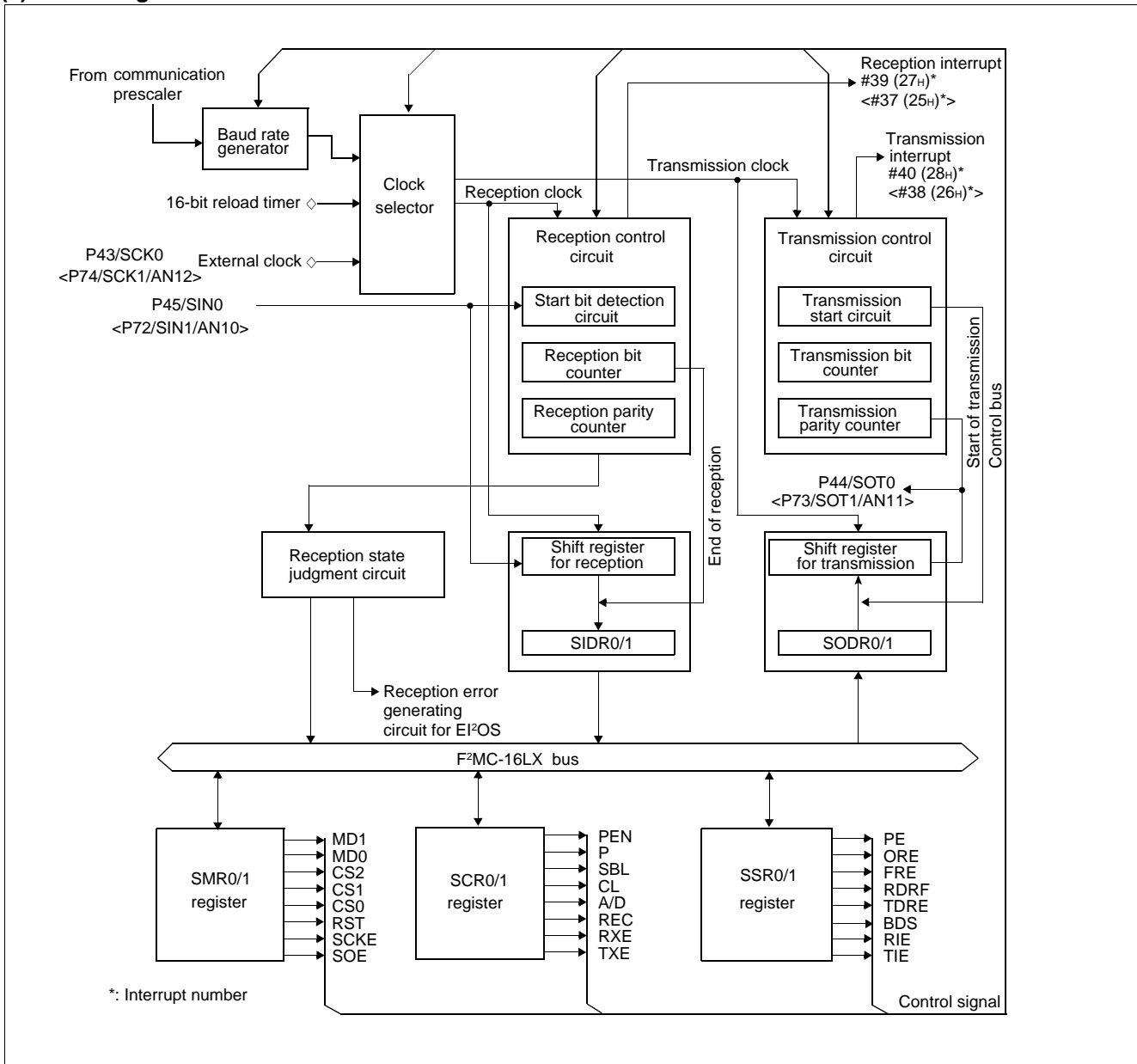

# MB90820 Series

## 10. DTP/External Interrupts

The DTP/external interrupt circuit is activated by the signal supplied to a DTP/external interrupt pin. The CPU accepts the signal using the same procedure it uses for normal hardware interrupts and generates external interrupts or activates the extended intelligent I/O service (EI<sup>2</sup>OS).

Features of DTP/External Interrupt :

- Total 8 external interrupt channels.
- Two request levels (“H” and “L”) are provided for the intelligent I/O service.
- Four request levels (rising edge, falling edge, “H” level and “L” level) are provided for external interrupt requests.

### (1) Register configuration

DTP/Interrupt Source Register									
	15	14	13	12	11	10	9	8	⇐ Bit
Address: 0000031 <sub>H</sub>	ER7	ER6	ER5	ER4	ER3	ER2	ER1	ER0	EIRR
Read/write ⇨	R/W	R/W	R/W	R/W	R/W	R/W	R/W	R/W	
Initial value ⇨	0	0	0	0	0	0	0	0	
DTP/Interrupt Enable Register									
	7	6	5	4	3	2	1	0	⇐ Bit
Address: 000030 <sub>H</sub>	EN7	EN6	EN5	EN4	EN3	EN2	EN1	EN0	ENIR
Read/write ⇨	R/W	R/W	R/W	R/W	R/W	R/W	R/W	R/W	
Initial value ⇨	0	0	0	0	0	0	0	0	
Request Level Setting Register (Upper)									
	15	14	13	12	11	10	9	8	⇐ Bit
Address: 0000033 <sub>H</sub>	LB7	LA7	LB6	LA6	LB5	LA5	LB4	LA4	ELVRH
Read/write ⇨	R/W	R/W	R/W	R/W	R/W	R/W	R/W	R/W	
Initial value ⇨	0	0	0	0	0	0	0	0	
Request Level Setting Register (Lower)									
	7	6	5	4	3	2	1	0	⇐ Bit
Address: 000032 <sub>H</sub>	LB3	LA3	LB2	LA2	LB1	LA1	LB0	LA0	ELVRL
Read/write ⇨	R/W	R/W	R/W	R/W	R/W	R/W	R/W	R/W	
Initial value ⇨	0	0	0	0	0	0	0	0	



## (2) Block diagram

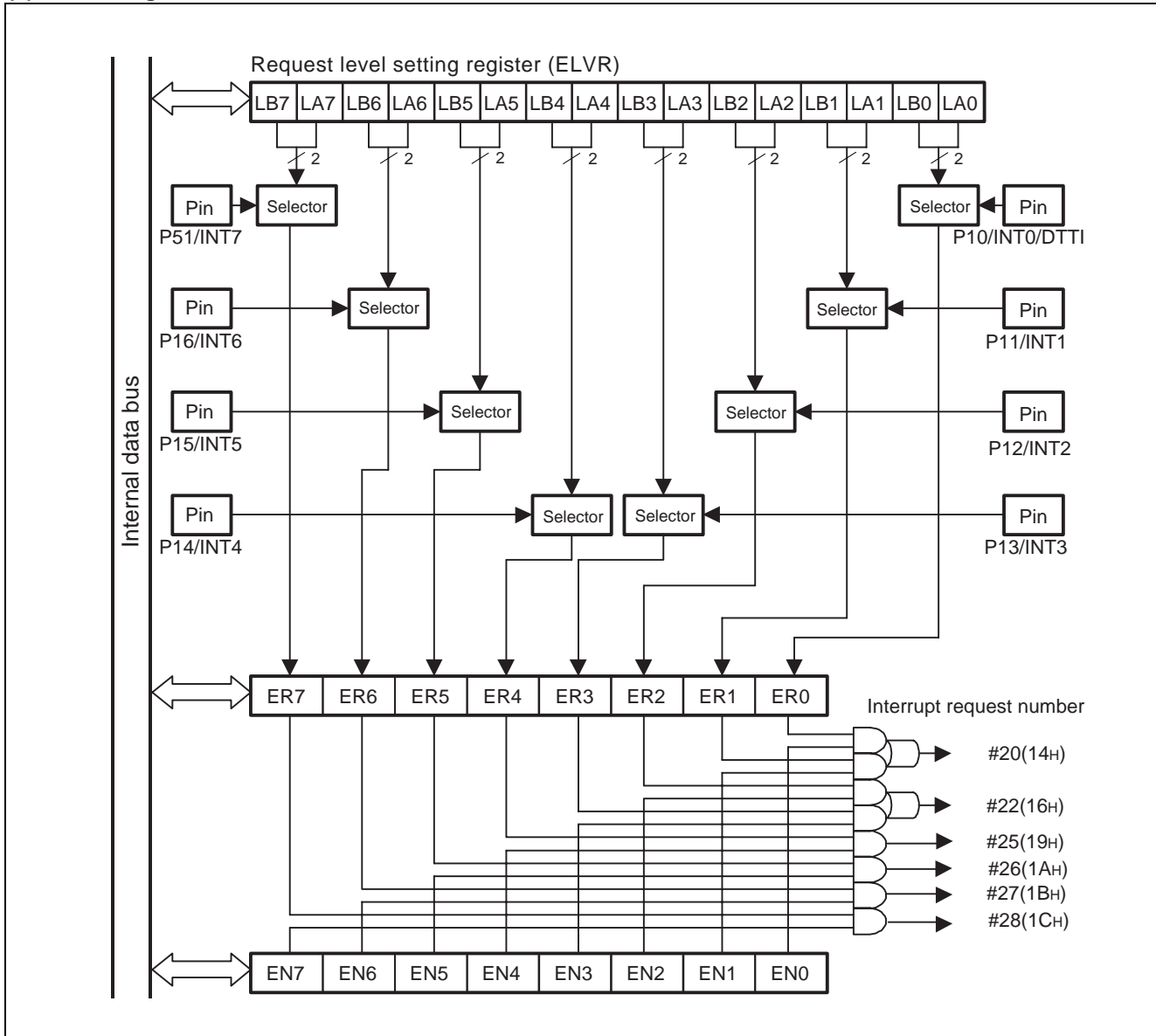

# MB90820 Series

## 11. Delayed Interrupt Generation Module

The delayed interrupt generation module is used to generate a task switching interrupt. Interrupt requests to the F<sup>2</sup>MC-16LX CPU can be generated and cleared by software using this module.

### (1) Register configuration

Delay interrupt cause/clear register									
	15	14	13	12	11	10	9	8	Bit
Address: 00009F <sub>H</sub>	–	–	–	–	–	–	–	R0	DIRR
Read/write ⇨	–	–	–	–	–	–	–	R/W	
Initial value ⇨	X	X	X	X	X	X	X	0	

### (2) Block diagram

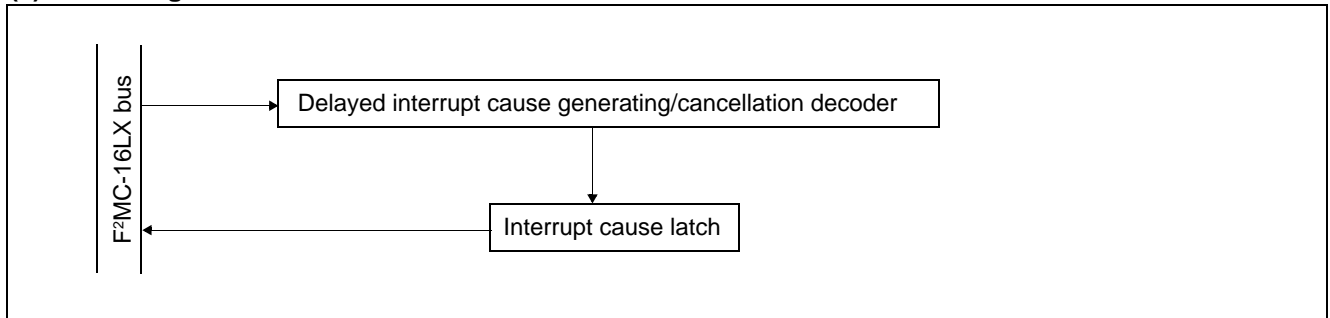

## 12. A/D Converter

The A/D converter converts the analog voltage input (input voltage) to an analog input pin to a digital value. It has the following features :

- The minimum conversion time is 3  $\mu$ s (for a machine clock of 24 MHz; including sampling time).
- The converter uses the RC-type successive approximation conversion method with a sample and hold circuit.
- A resolution of 10 bits or 8 bits can be set.
- Up to 16 channels for analog input pins can be selected by a program.
- Various conversion mode :
  - Single conversion mode : Selectively convert one channel.
  - Scan conversion mode : Continuously convert multiple channels. Maximum of 16 selectable channels.
  - Continuous conversion mode : Repeatedly convert specified channels.
  - Stop conversion mode : Convert one channel then halt until the next activation (enables synchronization of the conversion start timing).
- At the end of A/D conversion, an interrupt request can be generated and EI<sup>2</sup>OS can be activated.
- In the interrupt-enabled state, the conversion data protection function prevents any part of the data from being lost through continuous conversion.
- The conversion can be activated by software, 16-bit reload timer 1 (rising edge) and 16-bit free-running timer zero detection edge.

### (1) Register configuration

A/D Control Status Register 1 (upper)

	15	14	13	12	11	10	9	8	Bit
Address: 00000C7 <sub>H</sub>	BUSY	INT	INTE	PAUS	STS1	STS0	STRT	–	ADCS1
Read/write ⇔	R/W	R/W	R/W	R/W	R/W	R/W	W	–	
Initial value ⇔	0	0	0	0	0	0	0	X	

A/D Control Status Register 0 (lower)

	7	6	5	4	3	2	1	0	Bit
Address: 0000C6 <sub>H</sub>	MD1	MD0	S10	–	–	–	–	Reserved	ADCS0
Read/write ⇔	R/W	R/W	R/W	–	–	–	–	–	
Initial value ⇔	0	0	0	X	X	X	X	0	

A/D Data Register 1 (upper)

	15	14	13	12	11	10	9	8	Bit
Address: 00000C9 <sub>H</sub>	–	–	–	–	–	–	D9	D8	ADCR1
Read/write ⇔	–	–	–	–	–	–	R	R	
Initial value ⇔	X	X	X	X	X	X	X	X	

A/D Data Register 0 (lower)

	7	6	5	4	3	2	1	0	Bit
Address: 0000C8 <sub>H</sub>	D7	D6	D5	D4	D3	D2	D1	D0	ADCR0
Read/write ⇔	R	R	R	R	R	R	R	R	
Initial value ⇔	X	X	X	X	X	X	X	X	

(Continued)

# MB90820 Series

(Continued)

## A/D Setting Register 1 (upper)

	15	14	13	12	11	10	9	8	↔ Bit
Address: 00000CB <sub>H</sub>	ST2	ST1	ST0	CT2	CT1	CT0	Reserved	ANS3	ADSR1
Read/write ↔	R/W	R/W	R/W	R/W	R/W	R/W	R/W	R/W	
Initial value ↔	0	0	0	0	0	0	0	0	

## A/D Setting Register 0 (lower)

	7	6	5	4	3	2	1	0	↔ Bit
Address: 0000CA <sub>H</sub>	ANS2	ANS1	ANS0	Reserved	ANE3	ANE2	ANE1	ANE0	ADSR0
Read/write ↔	R/W	R/W	R/W	R/W	R/W	R/W	R/W	R/W	
Initial value ↔	0	0	0	0	0	0	0	0	

## A/D Input Enable Register 0

	15	14	13	12	11	10	9	8	↔ Bit
Address: 00000C5 <sub>H</sub>	ADE7	ADE6	ADE5	ADE4	ADE3	ADE2	ADE1	ADE0	ADER0
Read/write ↔	R/W	R/W	R/W	R/W	R/W	R/W	R/W	R/W	
Initial value ↔	1	1	1	1	1	1	1	1	

## A/D Input Enable Register 1

	7	6	5	4	3	2	1	0	↔ Bit
Address: 0000D0 <sub>H</sub>	ADE15	ADE14	ADE13	ADE12	ADE11	ADE10	ADE9	ADE8	ADER1
Read/write ↔	R/W	R/W	R/W	R/W	R/W	R/W	R/W	R/W	
Initial value ↔	1	1	1	1	1	1	1	1	

## (2) Block diagram

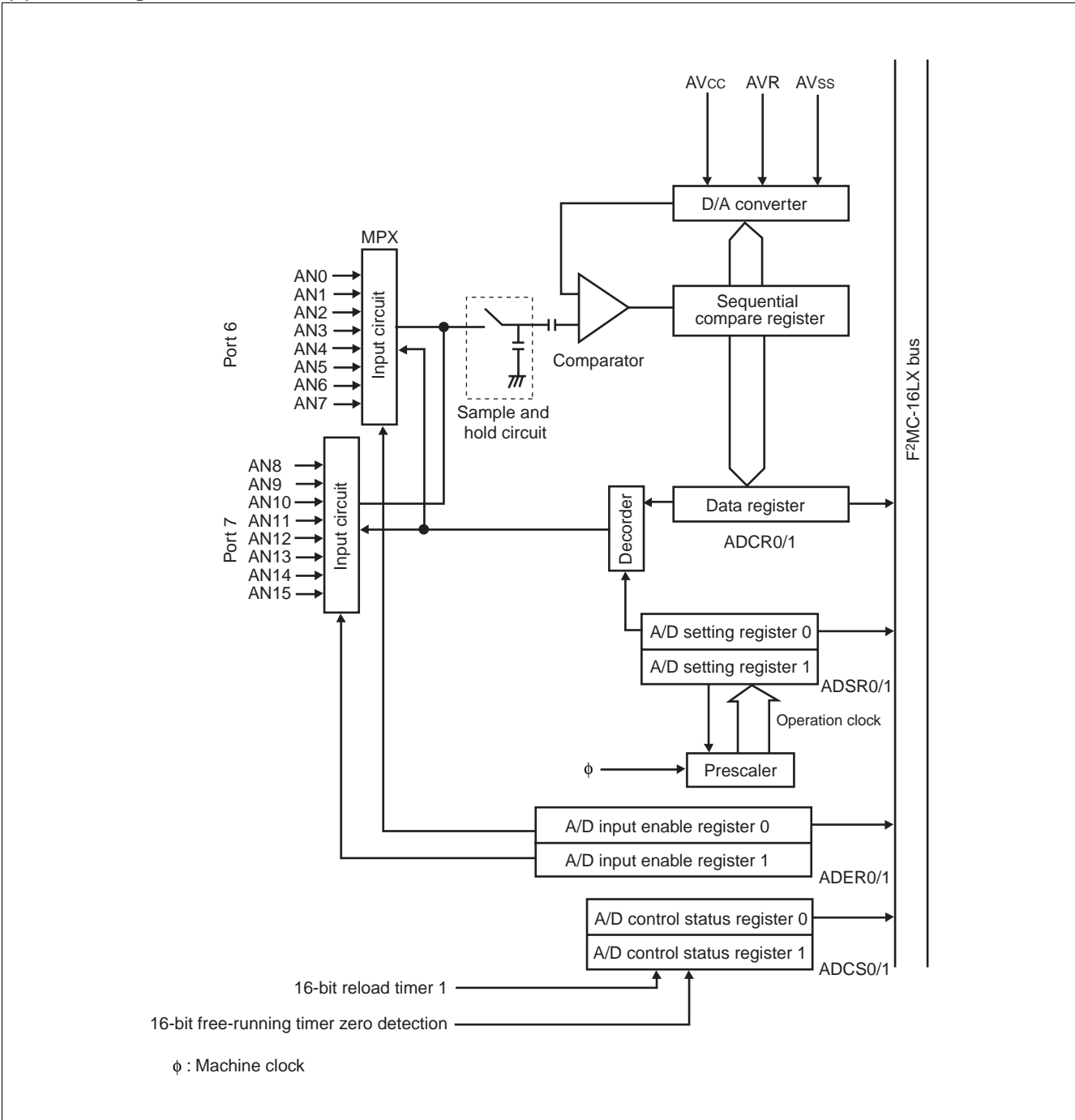

## 13. D/A Converter

The D/A converter is used to generate an analog output from an 8-bit digital input. By setting the enable bit in the D/A control register (DACR) to 1, it will enable the corresponding D/A output channel. Hence, setting this bit to 0 will disable that channel.

If D/A output is disabled, the analog switch inserted to the output of each D/A converter channel in series is turned off. In the D/A converter, the bit is cleared to 0 and the direct-current path is shut off. The above is also true in the stop mode.

The output voltage of the D/A converter ranges from 0 V to  $255/256 \times AV_{CC}$ . To change the output voltage range, adjust the  $AV_{CC}$  voltage externally.

The D/A converter output does not have the internal buffer amplifier. The analog switch (= 100  $\Omega$ ) is inserted to the output in series. To apply load to the output externally, estimate a sufficient stabilization time.

Table below lists the theoretical values of output voltage of the D/A converter.

Value written to DA07 to DA00 and DA17 to DA10	Theoretical value of output voltage
00 <sub>H</sub>	$0/256 \times AV_{CC} (= 0 \text{ V})$
01 <sub>H</sub>	$1/256 \times AV_{CC}$
02 <sub>H</sub>	$2/256 \times AV_{CC}$
:	:
FD <sub>H</sub>	$253/256 \times AV_{CC}$
FE <sub>H</sub>	$254/256 \times AV_{CC}$
FF <sub>H</sub>	$255/256 \times AV_{CC}$

## (1) Register configuration

### D/A data register 1

Bit	15	14	13	12	11	10	9	8	
Address:0000CDH	DA17	DA16	DA15	DA14	DA13	DA12	DA11	DA10	DAT1
Read/write →	R/W	R/W	R/W	R/W	R/W	R/W	R/W	R/W	
Initial value →	X	X	X	X	X	X	X	X	

### D/A data register 0

Bit	7	6	5	4	3	2	1	0	
Address:0000CCH	DA07	DA06	DA05	DA04	DA03	DA02	DA01	DA00	DAT0
Read/write →	R/W	R/W	R/W	R/W	R/W	R/W	R/W	R/W	
Initial value →	X	X	X	X	X	X	X	X	

### D/A control register 1

Bit	15	14	13	12	11	10	9	8	
Address:0000CFH	-	-	-	-	-	-	-	DAE1	DACR1
Read/write →	-	-	-	-	-	-	-	R/W	
Initial value →	X	X	X	X	X	X	X	0	

### D/A control register 0

Bit	7	6	5	4	3	2	1	0	
Address:0000CEH	-	-	-	-	-	-	-	DAE0	DACR0
Read/write →	-	-	-	-	-	-	-	R/W	
Initial value →	X	X	X	X	X	X	X	0	

# MB90820 Series

## (2) Block diagram

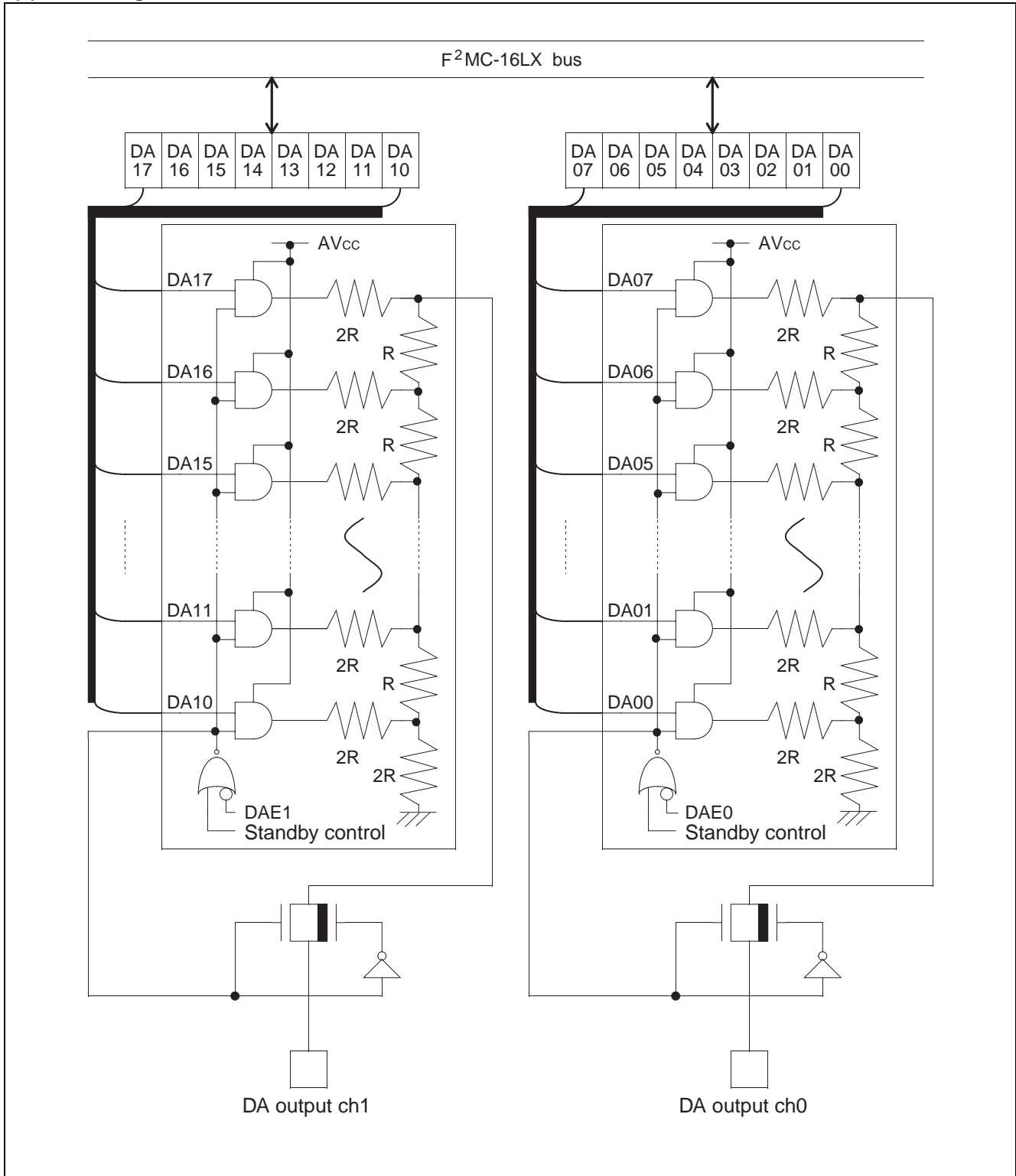



## 14. ROM Correction Function

When the corresponding address matches the value set in the address detection register, the instruction code to be loaded into the CPU is forced to be replaced with the INT9 instruction code (01H). When executing a set instruction, the CPU executes the INT9 instruction. The address detection function is implemented by processing using the INT9 instruction routine.

The device contains two address detection registers, each provided with a compare enable bit. When the value set in the address detection register matches an address and the interrupt enable bit is "1", the instruction code to be loaded into the CPU is forced to be replaced with the INT9 instruction code.

### (1) Register configuration

Program Address Detection Control Status Register									
	7	6	5	4	3	2	1	0	⇐ Bit
Address: 00009EH	-	-	-	-	AD1E	AD1D	AD0E	AD0D	PACSR
Read/write ⇐	-	-	-	-	R/W	R/W	R/W	R/W	
Initial value ⇐	X	X	X	X	0	0	0	0	
Program Address Detection Register 0 (Upper Byte)									
	7	6	5	4	3	2	1	0	⇐ Bit
Address: 001FF2H									PADRH0
Read/write ⇐	R/W	R/W	R/W	R/W	R/W	R/W	R/W	R/W	
Initial value ⇐	X	X	X	X	X	X	X	X	
Program Address Detection Register 0 (Middle Byte)									
	15	14	13	12	11	10	9	8	⇐ Bit
Address: 001FF1H									PADRM0
Read/write ⇐	R/W	R/W	R/W	R/W	R/W	R/W	R/W	R/W	
Initial value ⇐	X	X	X	X	X	X	X	X	
Program Address Detection Register 0 (Lower Byte)									
	7	6	5	4	3	2	1	0	⇐ Bit
Address: 001FF0H									PADRL0
Read/write ⇐	R/W	R/W	R/W	R/W	R/W	R/W	R/W	R/W	
Initial value ⇐	X	X	X	X	X	X	X	X	
Program Address Detection Register 1 (Upper Byte)									
	15	14	13	12	11	10	9	8	⇐ Bit
Address: 001FF5H									PADRH1
Read/write ⇐	R/W	R/W	R/W	R/W	R/W	R/W	R/W	R/W	
Initial value ⇐	X	X	X	X	X	X	X	X	

(Continued)

# MB90820 Series

(Continued)

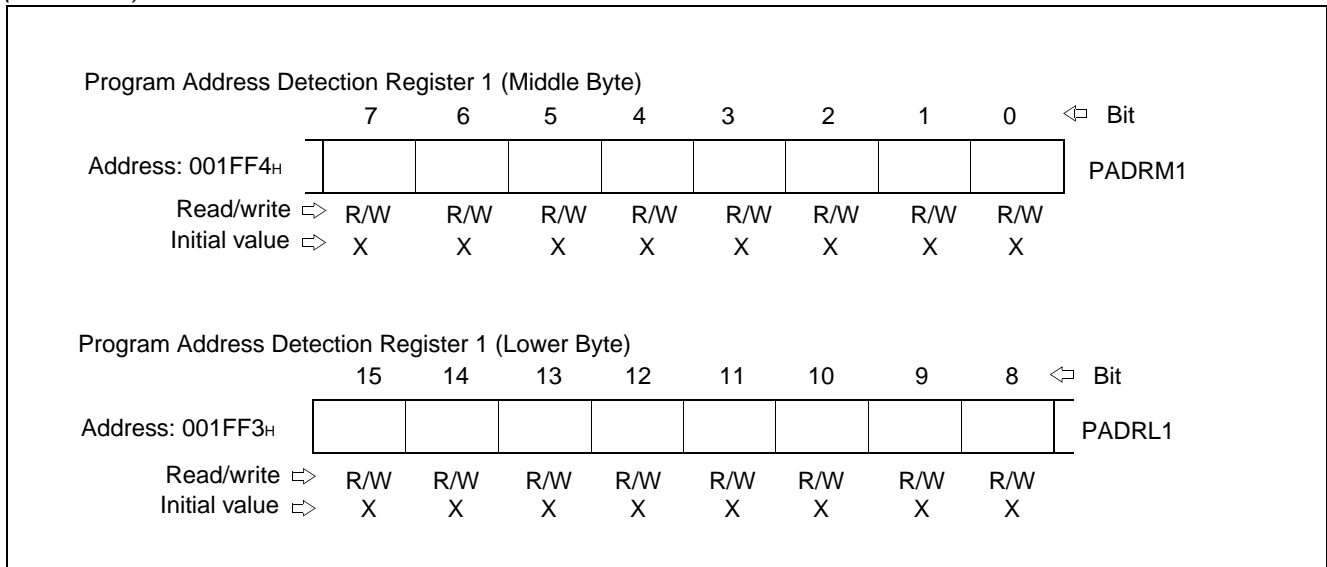

## (2) Block diagram

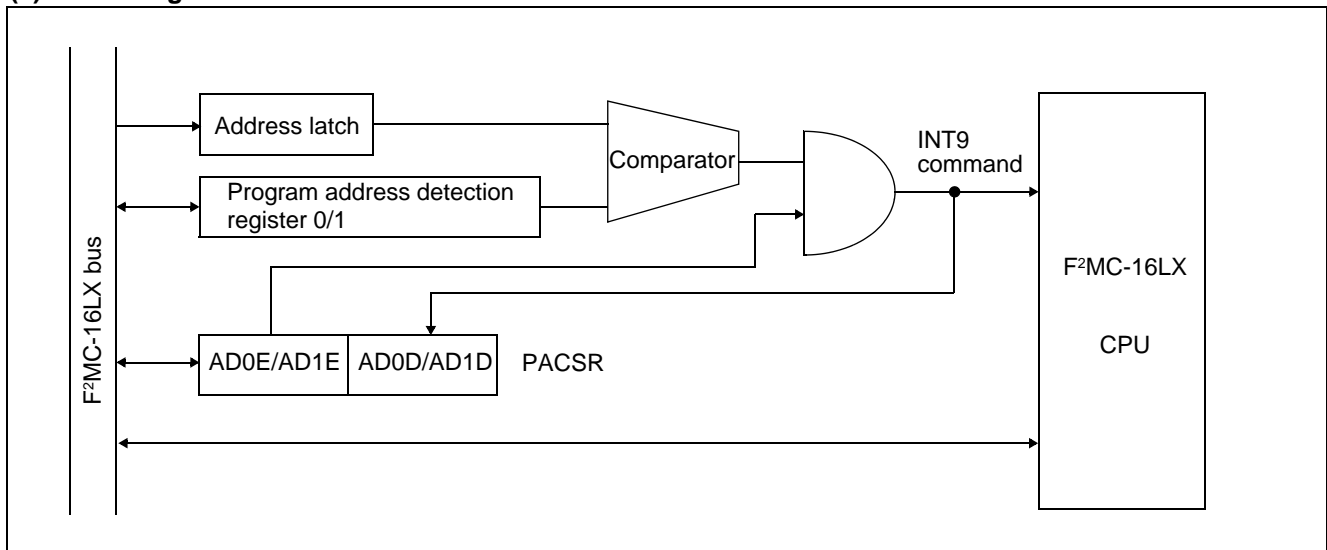

## 15. ROM Mirroring Function Selection Module

The ROM mirror function selection module sets the data in ROM assigned to FF bank so that the data is read by access to 00 bank.

### (1) Register configuration

ROM Mirror Function Selection Register									
	15	14	13	12	11	10	9	8	Bit
Address : 00006FH	–	–	–	–	–	–	–	M1	ROMM
Read/write ⇨	–	–	–	–	–	–	–	R/W	
Initial value ⇨	X	X	X	X	X	X	X	1	

### (2) Block diagram

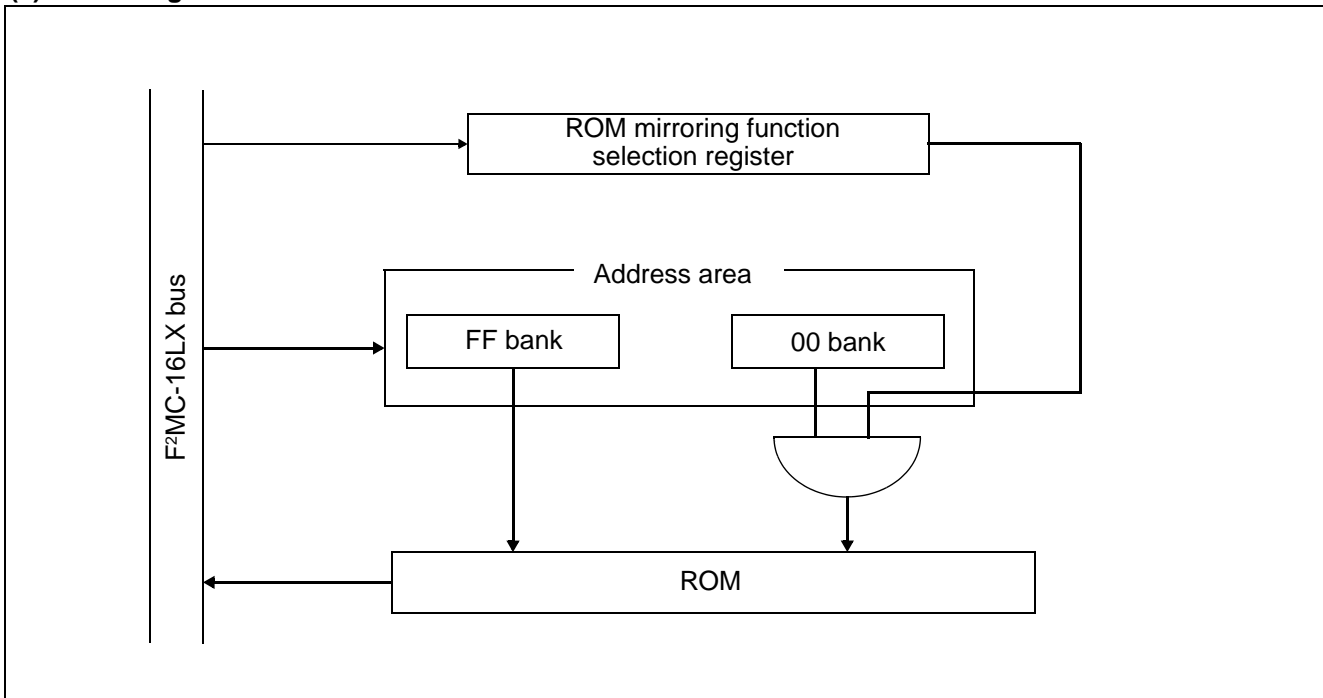

# MB90820 Series

## 16. 512K/1024K bits Flash Memory

The 512K bits flash memory is allocated in the FF<sub>H</sub> banks on the CPU memory map.

The 1024K bits flash memory is allocated in the FE<sub>H</sub> and FF<sub>H</sub> banks on the CPU memory map.

Like Mask ROM, flash memory is read-accessible and program-accessible to the CPU using the flash memory interface circuit. The flash memory can be programmed/erased by the instruction from the CPU via the flash memory interface circuit. The flash memory can therefore be reprogrammed (updated) while still on the circuit board under integrated CPU control, allowing program code and data to be improved efficiently.

Note that sector operations such as “enable sector protect” cannot be used.

Features of 512K/1024K bits flash memory

- 64K × 8 bits/32K × 16 bits (32K + 8K × 2 + 16K) sector configuration for 512K bits flash memory
- 128K × 8 bits/64K × 16 bits (64K + 32K + 8K × 2 + 16K) sector configuration for 1024K bits flash memory
- Automatic program algorithm (same as the Embedded Algorithm\* : MBM29F400TA)
- Installation of the deletion temporary stop/delete restart function
- Write/delete completion detected by the data polling or toggle bit
- Write/delete completion detected by the CPU interrupt
- Compatibility with the JEDEC standard-type command
- Each sector deletion can be executed (sectors can be freely combined)
- Flash security function
- Number of write/delete operations are guaranteed 10,000 times.

\* : Embedded Algorithm is a trademark of Advanced Micro Devices, Inc.

### (1) Register configuration

Flash Memory Control Status Register									Bit
	7	6	5	4	3	2	1	0	
Address: 0000AE <sub>H</sub>	INTE	RDYINT	WE	RDY	Reserved	Reserved	Reserved	Reserved	FMCS
Read/write ⇨	R/W	R/W	R/W	R	—	—	—	—	
Initial value ⇨	0	0	0	X	0	0	0	0	

## (2) Sector configuration of flash memory

The flash memory has the sector configuration illustrated below. The addresses in the illustration are the upper and lower addresses of each sector.

When 512K bits flash memory is accessed from the CPU, SA0 to SA3 are allocated in the FF bank.

Flash memory	CPU address	*Writer address
SA3 (16K bytes)	FFFFFF <sub>H</sub>	7FFFF <sub>H</sub>
	FFC000 <sub>H</sub>	7C000 <sub>H</sub>
SA2 (8K bytes)	FFBFFF <sub>H</sub>	7BFFF <sub>H</sub>
	FFA000 <sub>H</sub>	7A000 <sub>H</sub>
SA1 (8K bytes)	FF9FFF <sub>H</sub>	79FFF <sub>H</sub>
	FF8000 <sub>H</sub>	78000 <sub>H</sub>
SA0 (32K bytes)	FF7FFF <sub>H</sub>	77FFF <sub>H</sub>
	FF0000 <sub>H</sub>	70000 <sub>H</sub>

When 1024K bits flash memory is accessed from the CPU, SA0 to SA4 are allocated in the FE and FF bank.

Flash memory	CPU address	*Writer address
SA4 (16K bytes)	FFFFFF <sub>H</sub>	7FFFF <sub>H</sub>
	FFC000 <sub>H</sub>	7C000 <sub>H</sub>
SA3 (8K bytes)	FFBFFF <sub>H</sub>	7BFFF <sub>H</sub>
	FFA000 <sub>H</sub>	7A000 <sub>H</sub>
SA2 (8K bytes)	FF9FFF <sub>H</sub>	79FFF <sub>H</sub>
	FF8000 <sub>H</sub>	78000 <sub>H</sub>
SA1 (32K bytes)	FF7FFF <sub>H</sub>	77FFF <sub>H</sub>
	FF0000 <sub>H</sub>	70000 <sub>H</sub>
SA0 (64K bytes)	FE7FFF <sub>H</sub>	6FFFF <sub>H</sub>
	FE0000 <sub>H</sub>	60000 <sub>H</sub>

\* : The writer address is the address corresponding to the CPU address when writing data from a parallel flash memory writer. Use the writer address when programming or erasing using a general-purpose parallel writer.

# MB90820 Series

## ■ ELECTRICAL CHARACTERISTICS

### 1. Absolute Maximum Ratings

Parameter	Symbol	Rating		Unit	Remarks
		Min	Max		
Power supply voltage*1	$V_{CC}$	$V_{SS} - 0.3$	$V_{SS} + 6.0$	V	
	$AV_{CC}$	$V_{SS} - 0.3$	$V_{SS} + 6.0$	V	$V_{CC} = AV_{CC}$ *2
	AVR	$V_{SS} - 0.3$	$V_{SS} + 6.0$	V	$AV_{CC} \geq AVR$ , $AVR \geq AV_{SS}$
Input voltage*1	$V_I$	$V_{SS} - 0.3$	$V_{SS} + 6.0$	V	*3
Output voltage*1	$V_O$	$V_{SS} - 0.3$	$V_{SS} + 6.0$	V	*3
Maximum clamp current	$I_{CLAMP}$	-2.0	+2.0	mA	*5
Total maximum clamp current	$\Sigma  I_{CLAMP} $	—	20	mA	*5
“L” level maximum output current	$I_{OL}$	—	15	mA	*4
“L” level average output current	$I_{OLAV1}$	—	4	mA	Except for P00 to P07, P82 to P87
	$I_{OLAV2}$	—	12	mA	P00 to P07, P82 to P87
“L” level total maximum output current	$\Sigma I_{OL}$	—	100	mA	
“L” level total average output current	$\Sigma I_{OLAV}$	—	50	mA	
“H” level maximum output current	$I_{OH}$	—	-15	mA	*4
“H” level average output current	$I_{OHAV}$	—	-4	mA	
“H” level total maximum output current	$\Sigma I_{OH}$	—	-100	mA	
“H” level total average output current	$\Sigma I_{OHAV}$	—	-50	mA	
Power consumption	$P_D$	—	430	mW	
Operating temperature	$T_A$	-40	+85	°C	
Storage temperature	$T_{stg}$	-55	+150	°C	

\*1 : This parameter is based on  $V_{SS} = AV_{SS} = 0.0$  V.

\*2 :  $AV_{CC}$  must never exceed  $V_{CC}$  when the power is turned on.

\*3 :  $V_I$  and  $V_O$  must never exceed  $V_{CC} + 0.3$  V. However if the maximum current to/from an input is limited by some means with external components, the  $I_{CLAMP}$  rating supersedes the  $V_I$  rating.

\*4 : The maximum output current is a peak value for a corresponding pin.

\*5 : • Applicable to pins: P00 to P07, P10 to P17, P20 to P27, P30 to P37, P40 to P47, P50, P51, P80 to P87.  
 • Use within recommended operating conditions.  
 • Use at DC voltage (current).  
 • The +B signal is an input signal exceeding  $V_{CC}$  voltage. The +B signal should always be applied a limiting resistance placed between the +B signal and the microcontroller.  
 • The value of the limiting resistance should be set so that when the +B signal is applied the input current to the microcontroller pin does not exceed rated values, either instantaneously or for prolonged periods.  
 • Note that when the microcontroller drive current is low, such as in the power saving modes, the +B input potential may pass through the protective diode and increase the potential at the  $V_{CC}$  pin, and this may affect other devices.

- Note that if a +B signal is input when the microcontroller power supply is off (not fixed at 0 V), the power supply is provided from the pins, so that incomplete operation may result.
- Note that if the +B input is applied during power-on, the power supply is provided from the pins and the resulting supply voltage may not be sufficient to operate the power-on reset.
- Care must be taken not to leave the +B input pin open.
- Note that analog system input/output pins (LCD drive pins and comparator input pins, etc.) other than the A/D input pins cannot accept +B input.
- Sample recommended circuits:

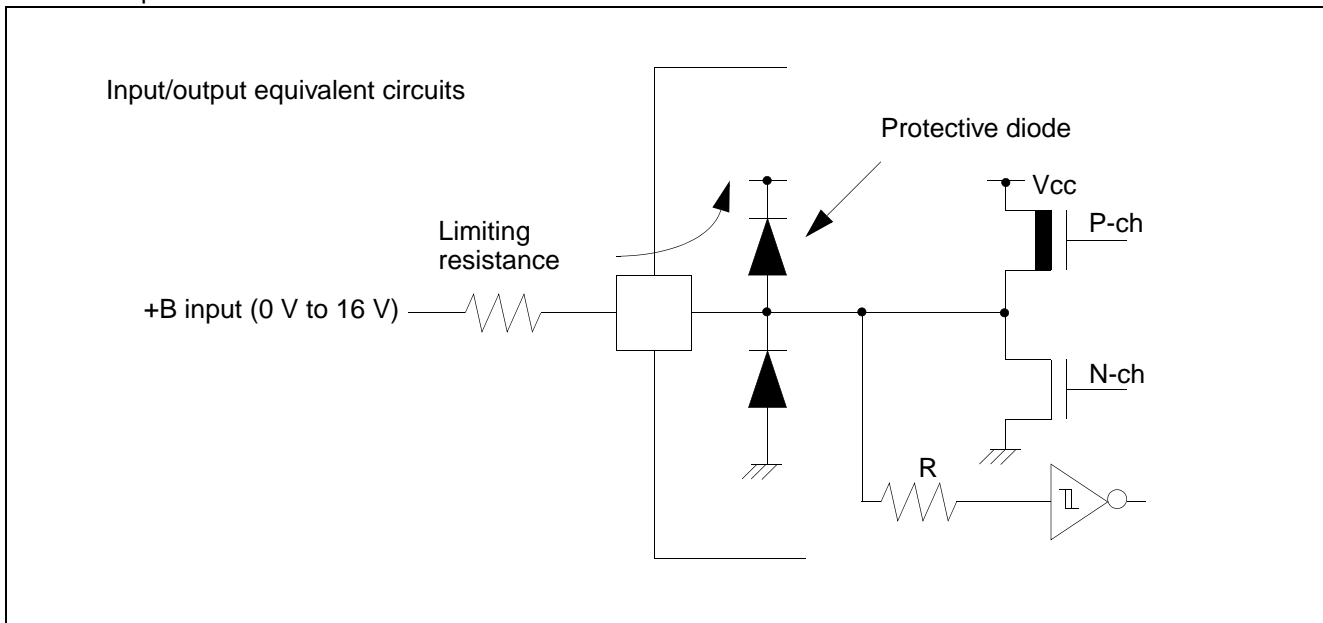

**WARNING:** Semiconductor devices can be permanently damaged by application of stress (voltage, current, temperature, etc.) in excess of absolute maximum ratings. Do not exceed these ratings.

# MB90820 Series

## 2. Recommended Operating Conditions

( $V_{SS} = AV_{SS} = 0.0\text{ V}$ )

Parameter	Symbol	Pin name	Condition	Value		Unit	Remarks
				Min	Max		
Power supply voltage	$V_{CC}$ $AV_{CC}$	—	—	4.5	5.5	V	At normal operation $T_A = -40\text{ °C}$ to $+85\text{ °C}$
		—	—	4.0	5.5	V	Normal operation when D/A converter is not used $T_A = -40\text{ °C}$ to $+85\text{ °C}$
		—	—	3.5	5.5	V	Normal operation when A/D converter and D/A converter are not used $T_A = -40\text{ °C}$ to $+85\text{ °C}$
		—	—	3.0	5.5	V	Maintains state in stop mode
“H” level input voltage	$V_{IH}$	P30 to P37, P60 to P67	$V_{CC} = 5\text{ V}$ $\pm 10\%$	$0.7 V_{CC}$	$V_{CC} + 0.3$	V	CMOS input
	$V_{IHS}$	P00 to P07, P10 to P17 P20 to P27, P40 to P44, P45*1, P46, P47, P50, P51, P70, P71, P72*1, P73 to P77, P80 to P87, $\overline{RST}$		$0.8 V_{CC}$	$V_{CC} + 0.3$	V	CMOS hysteresis input
	$V_{IHM}$	MD0, MD1, MD2		$V_{CC} - 0.3$	$V_{CC} + 0.3$	V	MD input
“L” level input voltage	$V_{IL}$	P30 to P37, P60 to P67		$V_{SS} - 0.3$	$0.3 V_{CC}$	V	CMOS input
	$V_{ILS}$	P00 to P07, P10 to P17 P20 to P27, P40 to P44, P45*1, P46, P47, P50, P51, P70, P71, P72*1, P73 to P77, P80 to P87 $\overline{RST}$		$V_{SS} - 0.3$	$0.2 V_{CC}$	V	CMOS hysteresis input
	$V_{ILM}$	MD0, MD1, MD2		$V_{SS} - 0.3$	$V_{SS} + 0.3$	V	MD input
Smoothing capacitor	$C_s$	—	—	0.1	1.0	$\mu\text{F}$	*2
Reference input voltage of A/D converter	AVR	—	—	2.7	$AV_{CC}$	V	
Operating temperature	$T_A$	—	—	-40	+85	$^{\circ}\text{C}$	

\*1 : UART ch0/1 data input pins P45/SIN0, P72/SIN1/AN10 can be used as CMOS input by the communication prescaler control register (CDRR).

\*2 : Use a ceramic capacitor or a capacitor with equivalent frequency characteristics. On the  $V_{CC}$  pin, connect a bypass capacitor that has a larger capacity than that of  $C_s$ . Refer to the following figure for connection of smoothing capacitor  $C_s$ .



• C pin connection circuit

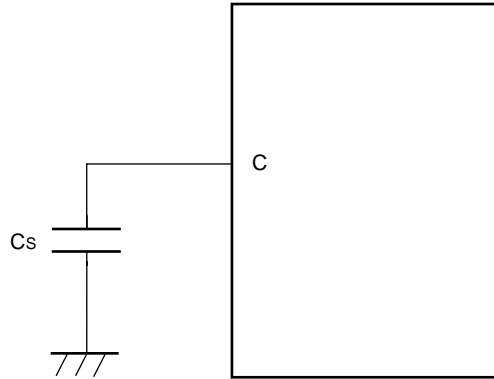

**WARNING:** The recommended operating conditions are required in order to ensure the normal operation of the semiconductor device. All of the device's electrical characteristics are warranted when the device is operated within these ranges.

Always use semiconductor devices within their recommended operating condition ranges. Operation outside these ranges may adversely affect reliability and could result in device failure.

No warranty is made with respect to uses, operating conditions, or combinations not represented on the data sheet. Users considering application outside the listed conditions are advised to contact their FUJITSU representatives beforehand.

# MB90820 Series

## 3. DC Characteristics

( $V_{CC} = 5.0\text{ V} \pm 10\%$ ,  $V_{SS} = AV_{SS} = 0.0\text{ V}$ ,  $T_A = -40\text{ }^\circ\text{C}$  to  $+85\text{ }^\circ\text{C}$ )

Parameter	Symbol	Pin name	Condition	Value			Unit	Remarks
				Min	Typ	Max		
"H" level output voltage	$V_{OH}$	All output pins	$V_{CC} = 4.5\text{ V}$ , $I_{OH} = -4.0\text{ mA}$	$V_{CC} - 0.5$	—	—	V	
"L" level output voltage	$V_{OL1}$	All pins except P00 to P07 P82 to P87	$V_{CC} = 4.5\text{ V}$ , $I_{OL1} = 4.0\text{ mA}$	—	—	0.4	V	
	$V_{OL2}$	P00 to P07 P82 to P87	$V_{CC} = 4.5\text{ V}$ , $I_{OL2} = 12.0\text{ mA}$	—	—	0.4	V	
Input leakage current	$I_{IL}$	All input pins	$V_{CC} = 5.5\text{ V}$ , $V_{SS} < V_I < V_{CC}$	-5	—	5	$\mu\text{A}$	At pull-up disabled
Pull-up resistance	$R_{UP}$	P00 to P07 P10 to P17 P20 to P27 P30 to P37 $\overline{RST}$	—	25	50	100	$\text{k}\Omega$	
Pull-down resistance	$R_{DOWN}$	MD2	—	25	50	100	$\text{k}\Omega$	Mask ROM product

(Continued)

# MB90820 Series

(Continued)

( $V_{CC} = 5.0 V \pm 10\%$ ,  $V_{SS} = AV_{SS} = 0.0 V$ ,  $T_A = -40\text{ }^\circ\text{C}$  to  $+85\text{ }^\circ\text{C}$ )

Parameter	Symbol	Pin name	Condition	Value			Unit	Remarks
				Min	Typ	Max		
Power supply current*	I <sub>CC</sub>	V <sub>CC</sub>	V <sub>CC</sub> = 5.0 V, Internal frequency: 24 MHz, At normal operation	—	35	50	mA	Mask ROM product
			—	45	60	mA	Flash memory product	
			V <sub>CC</sub> = 5.0 V, Internal frequency: 24 MHz, At writing in flash memory	—	60	75	mA	Flash memory product
			V <sub>CC</sub> = 5.0 V, Internal frequency: 24 MHz, At erasing memory	—	65	80	mA	Flash memory product
	I <sub>CCS</sub>		V <sub>CC</sub> = 5.0 V, Internal frequency: 24 MHz, At sleep mode	—	15	25	mA	Mask ROM product
			—	mA			Flash memory product	
	I <sub>CTS</sub>		V <sub>CC</sub> = 5.0 V, Internal frequency: 2 MHz, At main timer mode	—	0.3	0.8	mA	Mask ROM product
			—	mA			Flash memory product	
	I <sub>CTT</sub>		V <sub>CC</sub> = 5.0 V, Internal frequency: 8 MHz, At timer mode, T <sub>A</sub> = +25 °C	—	3	7	mA	Mask ROM product
			—	μA			Flash memory product	
I <sub>CCH</sub>	In stop mode, T <sub>A</sub> = +25 °C	—	5	20	mA	Mask ROM product		
		—			μA	Flash memory product		
Input capacitance	C <sub>IN</sub>	Except AV <sub>CC</sub> , AV <sub>SS</sub> , AVR, C, V <sub>CC</sub> and V <sub>SS</sub>	—	5	15	pF		

\* : The power supply current is regulated with an external clock.

# MB90820 Series

## 4. AC Characteristics

### (1) Clock Timings

( $V_{CC} = 5.0 V \pm 10\%$ ,  $V_{SS} = AV_{SS} = 0.0 V$ ,  $T_A = -40\text{ }^\circ\text{C}$  to  $+85\text{ }^\circ\text{C}$ )

Parameter	Symbol	Pin name	Value			Unit	Remarks
			Min	Typ	Max		
Clock frequency	$F_C$	X0, X1	3	—	16	MHz	When using oscillation circuit
			3	—	24		When using external clock
			4	—	24		1 multiplied PLL
			4	—	12		2 multiplied PLL
			4	—	8		3 multiplied PLL
			4	—	6		4 multiplied PLL
			4	—	4		6 multiplied PLL
Clock cycle time	$t_{HCYL}$	X0, X1	62.5	—	333	ns	When using oscillation circuit
			41.67	—	333	ns	When using external clock
Input clock pulse width	$P_{WH}$ $P_{WL}$	X0	10	—	—	ns	When using external clock, duty ratio is about 30% to 70%.
Input clock rise/fall time	$t_{CR}$ $t_{CF}$	X0	—	—	5	ns	When using external clock
Internal operating clock frequency	$f_{CP}$	—	1.5	—	24	MHz	
Internal operating clock cycle time	$t_{CP}$	—	41.67	—	666	ns	

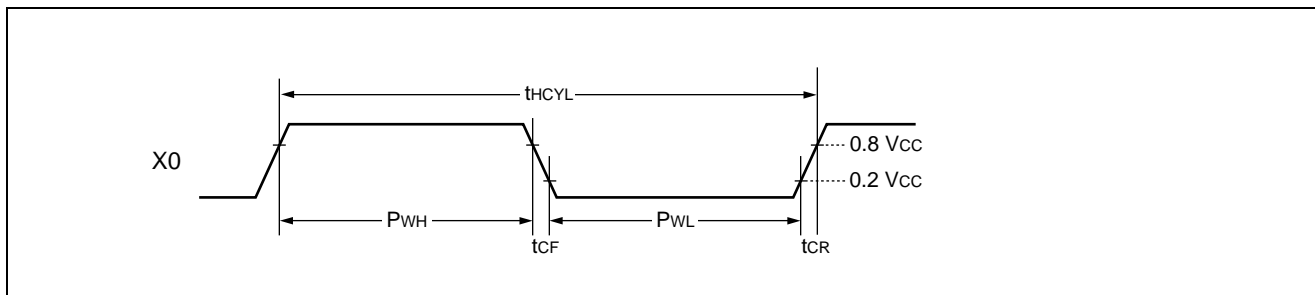

Relationship between internal operating clock frequency and power supply voltage

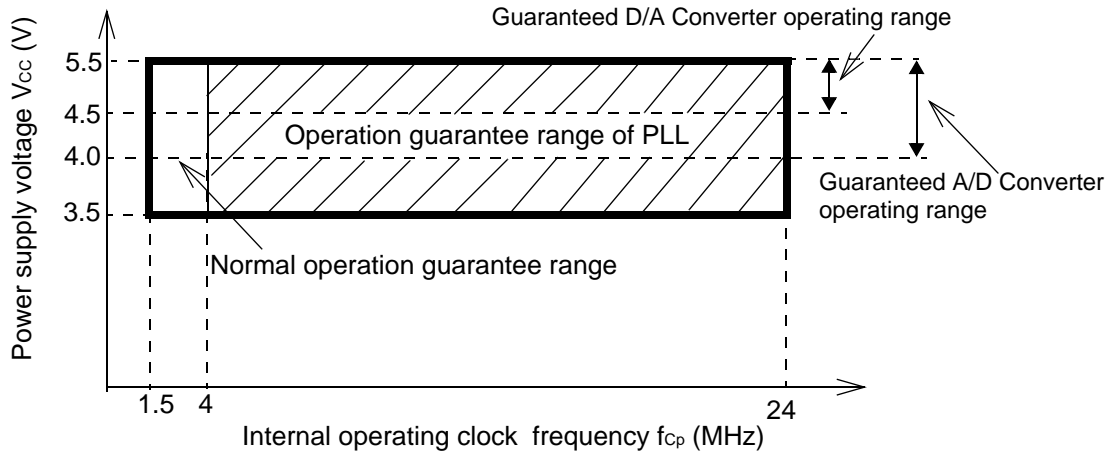

Relationship between clock frequency and internal operating clock frequency

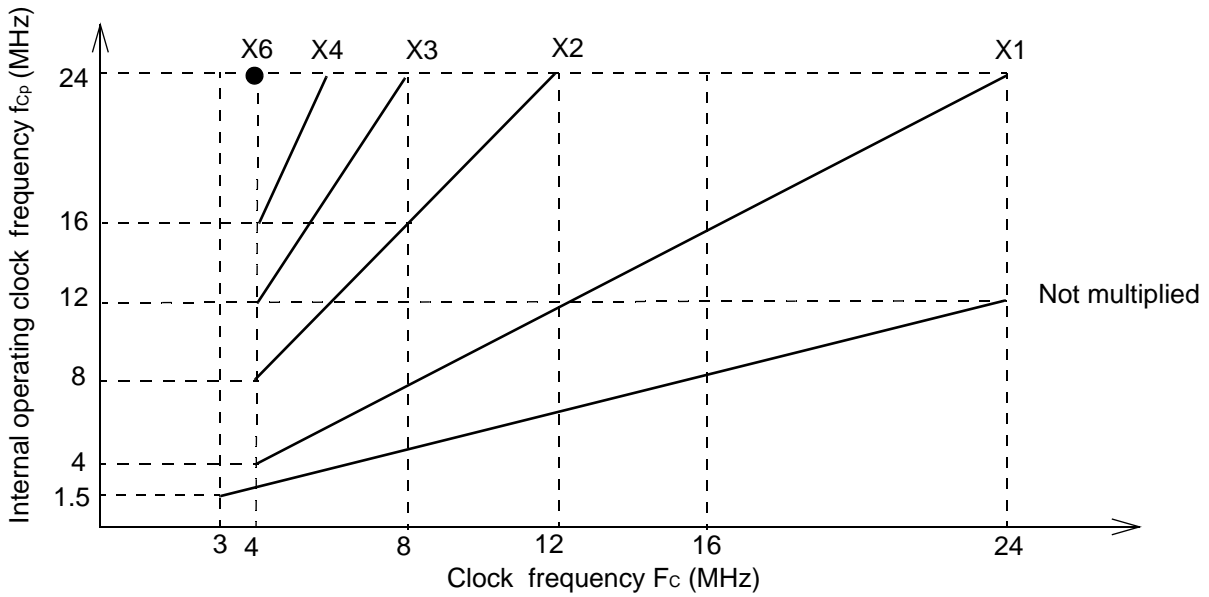

The AC ratings are measured for the following measurement reference voltages

• Input signal waveform

Hysteresis input pin

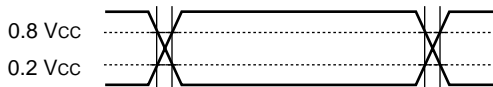

• Output signal waveform

Output pin

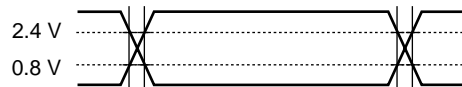

Pins other than hysteresis input/MD input

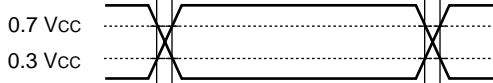

# MB90820 Series

## (2) External Reset

( $V_{CC} = 5.0\text{ V} \pm 10\%$ ,  $V_{SS} = AV_{SS} = 0.0\text{ V}$ ,  $T_A = -40\text{ }^\circ\text{C}$  to  $+85\text{ }^\circ\text{C}$ )

Parameter	Symbol	Pin name	Value		Unit	Remarks
			Min	Max		
Reset input time	$t_{RSTL}$	$\overline{\text{RST}}$	500	—	ns	In normal operation
			Oscillation time of oscillator* + 100	—	$\mu\text{s}$	In stop mode
			100	—	$\mu\text{s}$	In timebase timer mode

\* : Oscillation time of oscillator is the time to reach to 90% of the oscillation amplitude from stand still. In the crystal oscillator, the oscillation time is between several ms to tens of ms. In FAR/ceramic oscillator, the oscillation time is between hundreds of  $\mu\text{s}$  to several ms. In the external clock, the oscillation time is 0 ms.

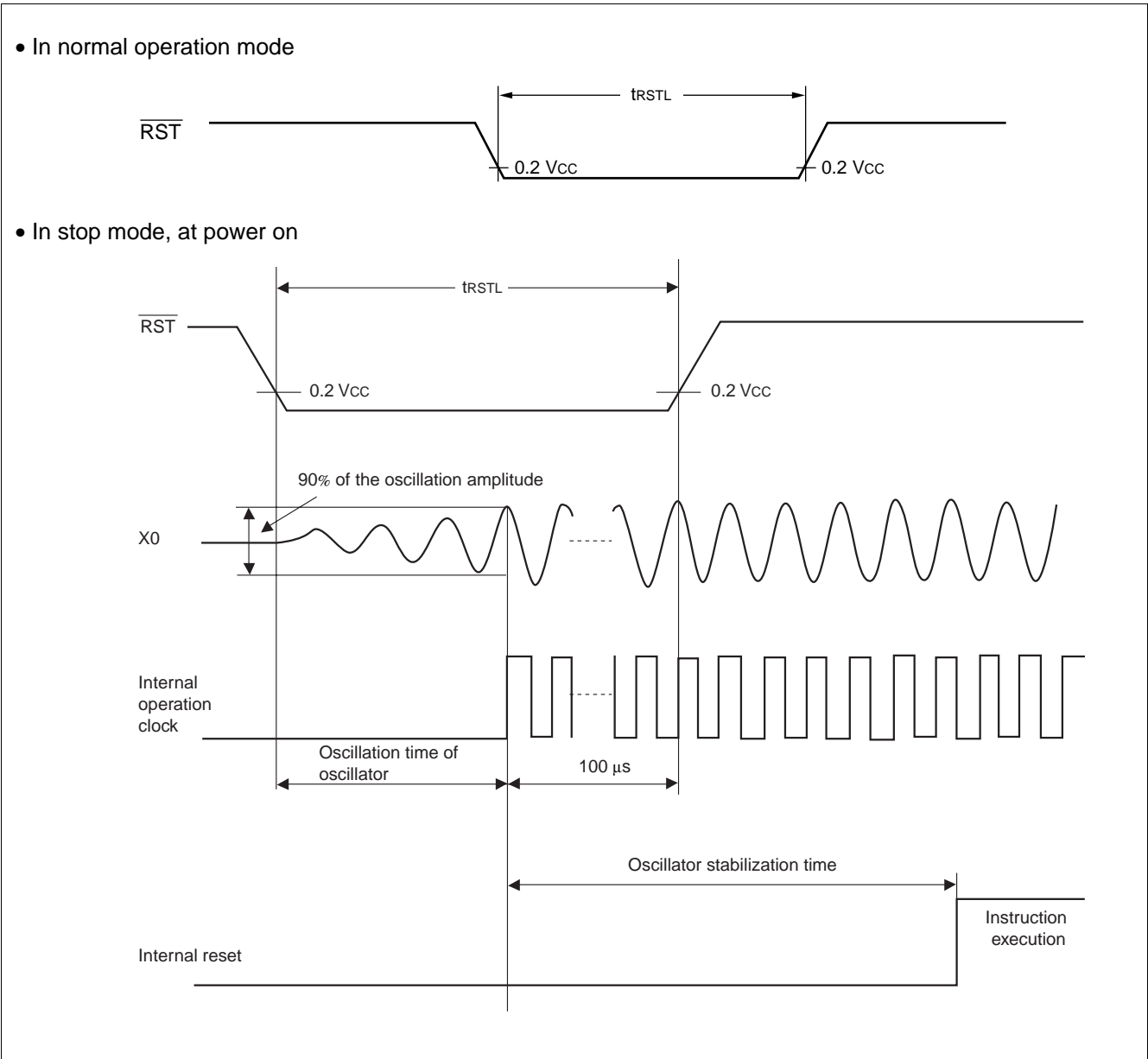

### (3) Power-on Reset

( $V_{CC} = 5.0\text{ V} \pm 10\%$ ,  $V_{SS} = AV_{SS} = 0.0\text{ V}$ ,  $T_A = -40\text{ }^\circ\text{C}$  to  $+85\text{ }^\circ\text{C}$ )

Parameter	Symbol	Pin name	Condition	Value		Unit	Remarks
				Min	Max		
Power supply rising time	$t_R$	$V_{CC}$	—	0.05	30	ms	
Power supply cut-off time	$t_{OFF}$	$V_{CC}$		1	—	ms	Waiting time for power supply on

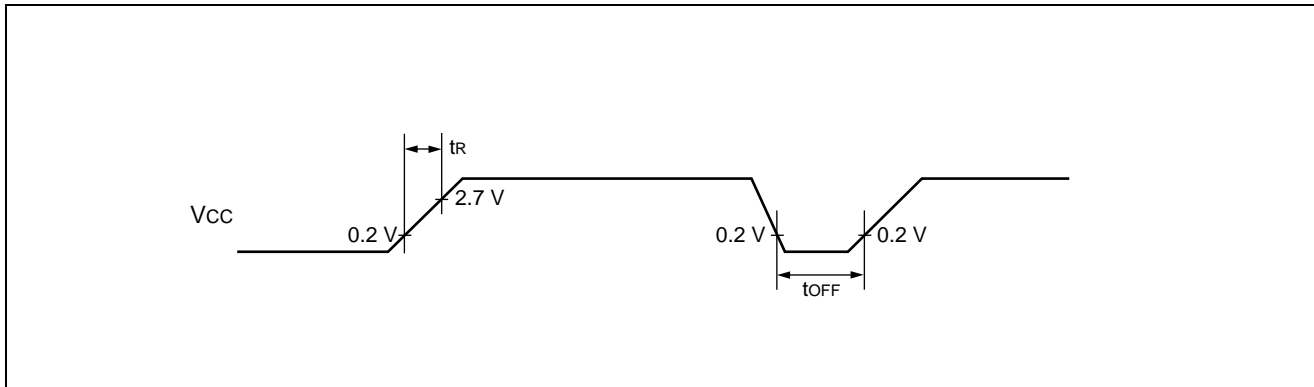

Note : Sudden changes in the power supply voltage may cause a power-on reset.

To change the power supply voltage while the device is in operation, be sure to set the slope of rising within 50 mV/ms or less as shown below.

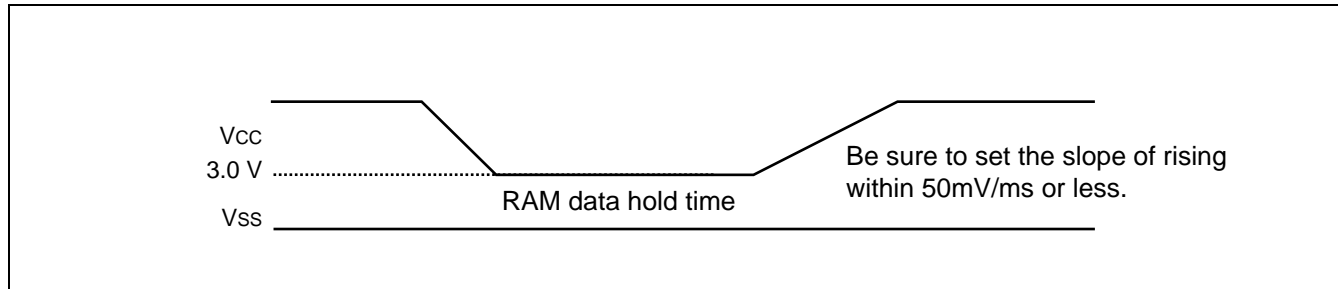

# MB90820 Series

## (4) UART0 and UART1

( $V_{CC} = 5.0 V \pm 10\%$ ,  $V_{SS} = AV_{SS} = 0.0 V$ ,  $T_A = -40\text{ }^\circ\text{C}$  to  $+85\text{ }^\circ\text{C}$ )

Parameter	Symbol	Pin name	Condition	Value		Unit	Remarks
				Min	Max		
Serial clock cycle time	$t_{SCYC}$	SCK0 to SCK1	$C_L = 80\text{ pF} + 1\text{ TTL}$ for an output pin of internal shift clock mode	8 $t_{CP}$	—	ns	
SCK ↓ → SOT delay time	$t_{SLOV}$	SCK0 to SCK1 SOT0 to SOT1		-80	+ 80	ns	
Valid SIN → SCK ↑	$t_{VSH}$	SCK0 to SCK1 SIN0 to SIN1		100	—	ns	
SCK ↑ → valid SIN hold time	$t_{SHIX}$	SCK0 to SCK1 SIN0 to SIN1		60	—	ns	
Serial clock "H" pulse width	$t_{SHSL}$	SCK0 to SCK1	$C_L = 80\text{ pF} + 1\text{ TTL}$ for an output pin of external shift clock mode	4 $t_{CP}$	—	ns	
Serial clock "L" pulse width	$t_{LSLH}$	SCK0 to SCK1		4 $t_{CP}$	—	ns	
SCK ↓ → SOT delay time	$t_{SLOV}$	SCK0 to SCK1 SOT0 to SOT1		—	150	ns	
Valid SIN → SCK ↑	$t_{VSH}$	SCK0 to SCK1 SIN0 to SIN1		60	—	ns	
SCK ↑ → valid SIN hold time	$t_{SHIX}$	SCK0 to SCK1 SIN0 to SIN1		60	—	ns	

- Notes :
- These are AC ratings in the CLK synchronous mode.
  - $C_L$  is the load capacitance value connected to pins while testing.
  - $t_{CP}$  is machine cycle time (unit : ns).



- Internal shift clock mode

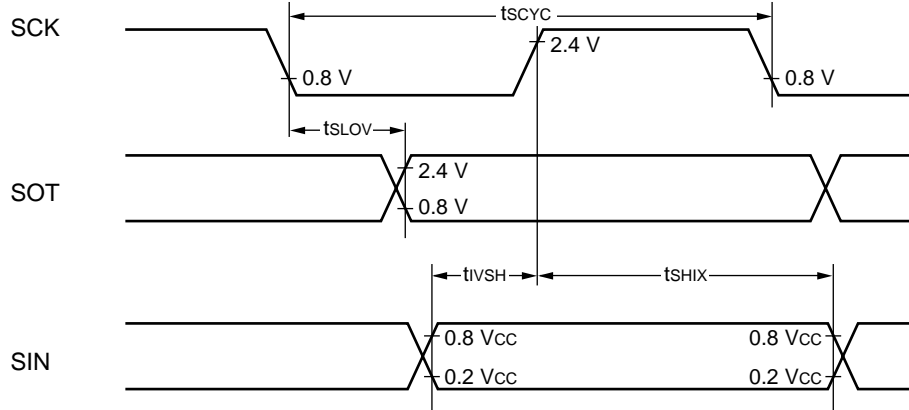

- External shift clock mode

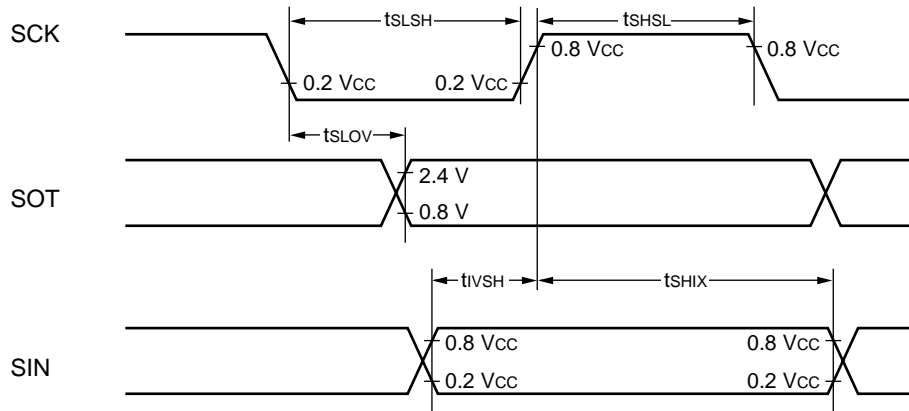

# MB90820 Series

## (5) Resources Input Timing

( $V_{CC} = 5.0 V \pm 10\%$ ,  $V_{SS} = AV_{SS} = 0.0 V$ ,  $T_A = -40\text{ }^\circ\text{C}$  to  $+85\text{ }^\circ\text{C}$ )

Parameter	Symbol	Pin name	Condition	Value		Unit	Remarks
				Min	Max		
Input pulse width	$t_{TIWH}$ $t_{TIWL}$	IN0 to IN3, TIN0 to TIN1, PW10 to PW11, DTTI	—	$4 t_{CP}$	—	ns	

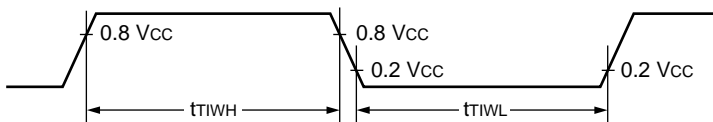

## (6) Trigger Input Timing

( $V_{CC} = 5.0 V \pm 10\%$ ,  $V_{SS} = AV_{SS} = 0.0 V$ ,  $T_A = -40\text{ }^\circ\text{C}$  to  $+85\text{ }^\circ\text{C}$ )

Parameter	Symbol	Pin name	Condition	Value		Unit	Remarks
				Min	Max		
Input pulse width	$t_{TRGH}$ $t_{TRGL}$	INT0 to INT7	—	$5 t_{CP}$	—	ns	

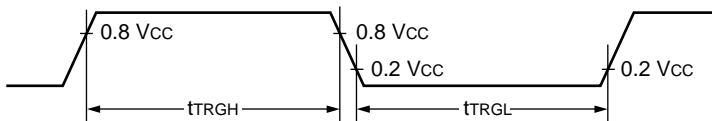

## 5. A/D Converter Electrical Characteristics

( $3.0\text{ V} \leq \text{AVR} - \text{AV}_{\text{SS}}$ ,  $V_{\text{CC}} = \text{AV}_{\text{CC}} = 5.0\text{ V} \pm 10\%$ ,  $V_{\text{SS}} = \text{AV}_{\text{SS}} = 0.0\text{ V}$ ,  $T_{\text{A}} = -40\text{ }^{\circ}\text{C}$  to  $+85\text{ }^{\circ}\text{C}$ )

Parameter	Symbol	Pin name	Value			Unit	Remarks
			Min	Typ	Max		
Resolution	—	—	—	10	—	bit	
Total error	—	—	—	—	$\pm 3.0$	LSB	
Non-linearity error	—	—	—	—	$\pm 2.5$	LSB	
Differential linearity error	—	—	—	—	$\pm 1.9$	LSB	
Zero transition voltage	$V_{\text{OT}}$	AN0 to AN15	$\text{AV}_{\text{SS}} - 1.5\text{ LSB}$	$\text{AV}_{\text{SS}} + 0.5\text{ LSB}$	$\text{AV}_{\text{SS}} + 2.5\text{ LSB}$	mV	
Full-scale transition voltage	$V_{\text{FST}}$	AN0 to AN15	$\text{AVR} - 3.5\text{ LSB}$	$\text{AVR} - 1.5\text{ LSB}$	$\text{AVR} + 0.5\text{ LSB}$	mV	
Compare time	—	—	1.0	—	—	$\mu\text{s}$	$4.5\text{ V} \leq \text{AV}_{\text{CC}} \leq 5.5\text{ V}$
			2.0	—	—	$\mu\text{s}$	$4.0\text{ V} \leq \text{AV}_{\text{CC}} < 4.5\text{ V}$
Sampling time	—	—	0.5	—	—	$\mu\text{s}$	$4.5\text{ V} \leq \text{AV}_{\text{CC}} \leq 5.5\text{ V}$
			1.2	—	—	$\mu\text{s}$	$4.0\text{ V} \leq \text{AV}_{\text{CC}} < 4.5\text{ V}$
Analog port input current	$I_{\text{AIN}}$	AN0 to AN15	- 0.3	—	+ 0.3	$\mu\text{A}$	
Analog input voltage	$V_{\text{AIN}}$	AN0 to AN15	$\text{AV}_{\text{SS}}$	—	AVR	V	
Reference voltage	—	AVR	$\text{AV}_{\text{SS}} + 2.7$	—	$\text{AV}_{\text{CC}}$	V	
Power supply current	$I_{\text{A}}$	$\text{AV}_{\text{CC}}$	—	2.4	4.7	mA	
	$I_{\text{AH}}$		—	—	5	$\mu\text{A}$	*
Reference voltage supply current	$I_{\text{R}}$	AVR	—	600	900	$\mu\text{A}$	
	$I_{\text{RH}}$		—	—	5	$\mu\text{A}$	*
Offset between channels	—	AN0 to AN15	—	—	4	LSB	

\* : The current when the A/D converter is not operating or the CPU is in stop mode (for  $V_{\text{CC}} = \text{AV}_{\text{CC}} = \text{AVR} = 5.0\text{ V}$ )

Note : The error increases proportionally as  $|\text{AVR} - \text{AV}_{\text{SS}}|$  decreases.

## 6. A/D Converter Glossary

- Resolution : Analog variation that is recognized by an A/D converter.
- Non linearity error : Deviation between a line across zero-transition line (“00 0000 0000”↔“00 0000 0001”) and full-scale transition line (“11 1111 1110”↔“11 1111 1111”) and actual conversion characteristics.
- Differential linearity error : Deviation of input voltage, which is required for changing output code by 1 LSB, from an ideal value
- Total error : Difference between an actual value and an ideal value. A total error includes zero transition error, full-scale transition error, and linear error.

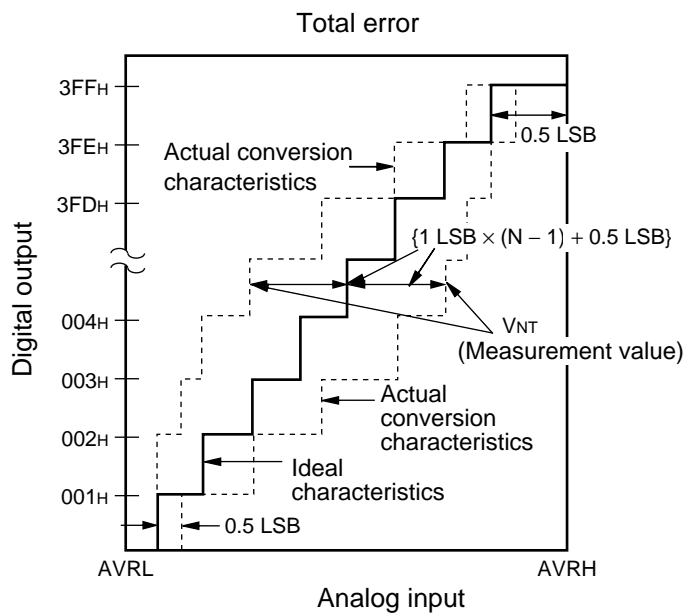

$$\text{Total error for digital output } N = \frac{V_{NT} - \{1 \text{ LSB} \times (N - 1) + 0.5 \text{ LSB}\}}{1 \text{ LSB}} \quad [\text{LSB}]$$

$$1 \text{ LSB} = (\text{Ideal value}) \frac{AVR - AV_{SS}}{1024} \quad [\text{V}]$$

N : A/D converter digital output value

$V_{OT}(\text{Ideal value}) = AV_{SS} + 0.5 \text{ LSB} \quad [\text{V}]$

$V_{FST}(\text{Ideal value}) = AVR - 1.5 \text{ LSB} \quad [\text{V}]$

$V_{NT}$  : Voltage at which of digital output transitions from (N - 1) to N.

(Continued)

(Continued)

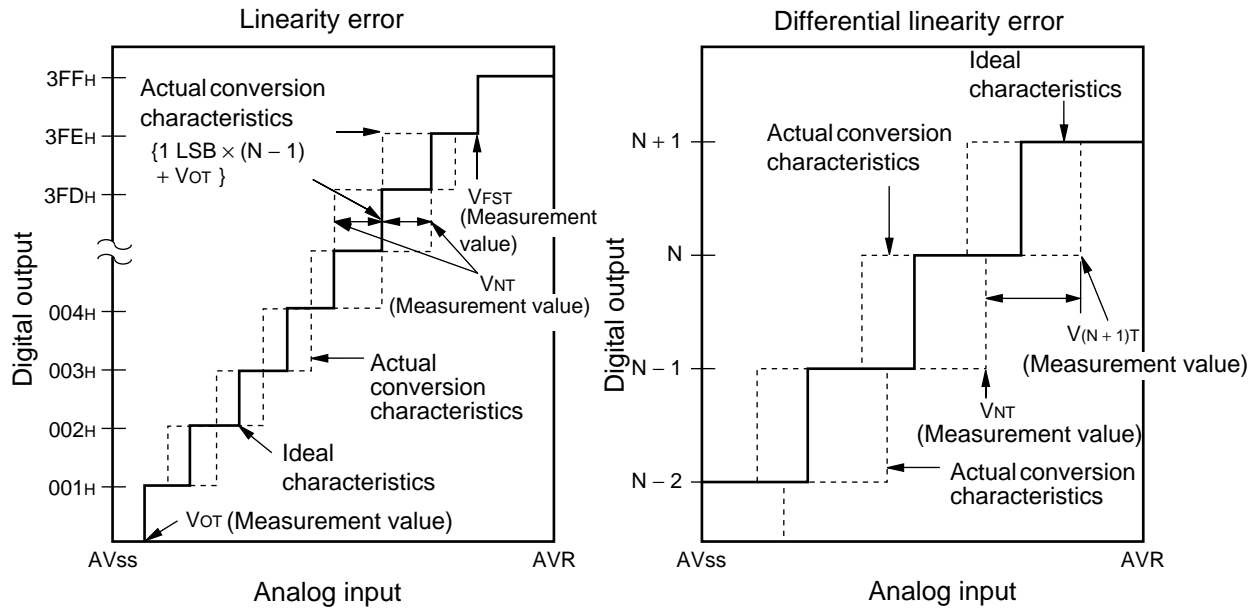

$$\text{Linearity error of digital output N} = \frac{V_{NT} - \{1 \text{ LSB} \times (N - 1) + V_{OT}\}}{1 \text{ LSB}} \quad [\text{LSB}]$$

$$\text{Differential linearity error of digital output N} = \frac{V_{(N+1)T} - V_{NT}}{1 \text{ LSB}} - 1 \quad [\text{LSB}]$$

$$1 \text{ LSB} = \frac{V_{FST} - V_{OT}}{1022} \quad [\text{V}]$$

N : A/D converter digital output value

$V_{OT}$  : Voltage at which of digital output transmissions from "000H" to "001H".

$V_{FST}$  : Voltage at which of digital output transmissions from "3FEH" to "3FFH".

# MB90820 Series

## 7. Notes on Using A/D Converter

### • About the external impedance of the analog input and its sampling time

- A/D converter with sample and hold circuit. If the external impedance is too high to keep sufficient sampling time, the analog voltage charged to the internal sample and hold capacitor is insufficient, adversely affecting A/D conversion precision. Therefore, to satisfy the A/D conversion precision standard, consider the relationship between the external impedance and minimum sampling time and either adjust the resistor value and operating frequency or decrease the external impedance so that the sampling time is longer than the minimum value. And if the sampling time cannot be sufficient, connect a capacitor of about 0.1 mF to the analog input pin.

#### • Analog input circuit model

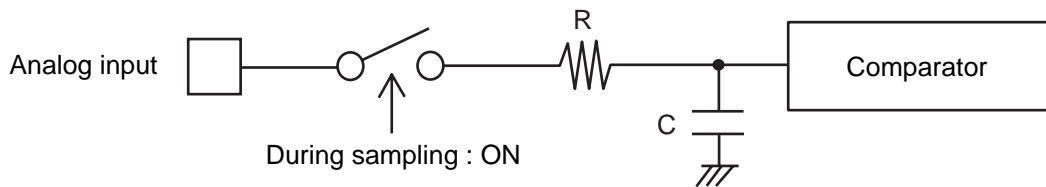

	R	C
MB90822/823	2.0 kΩ (Max)	14.4 pF (Max)
MB90F822A/F823A	2.0 kΩ (Max)	16.0 pF (Max)

Note : The values are reference values.

#### • The relationship between the external impedance and minimum sampling time

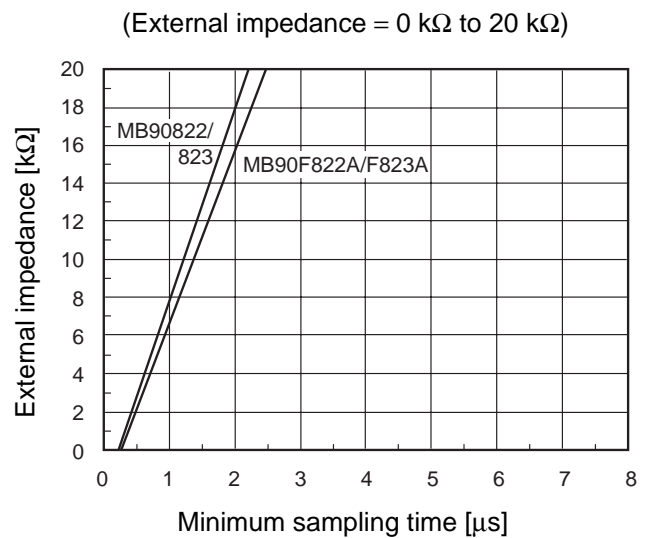
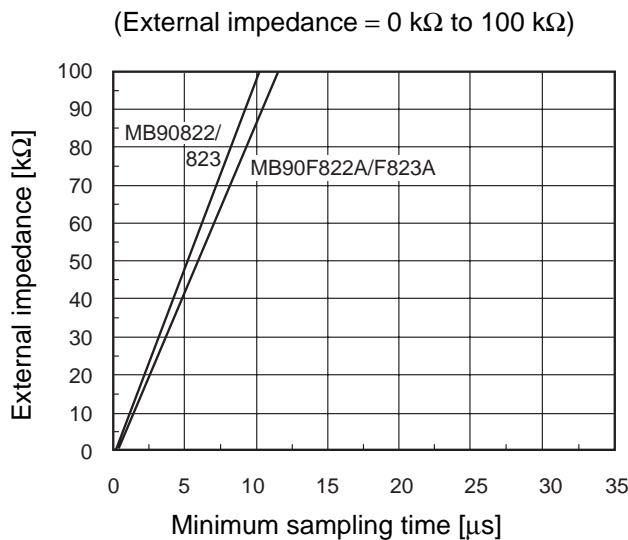

#### • About the error

The accuracy gets worse as  $|AVR - AV_{SS}|$  becomes smaller.

## 8. Electrical Characteristics of D/A convertor

( $V_{CC} = AV_{CC} = 4.5 \text{ V to } 5.5 \text{ V}$ ,  $V_{SS} = AV_{SS} = 0.0 \text{ V}$ ,  $T_A = -40 \text{ }^\circ\text{C to } +85 \text{ }^\circ\text{C}$ )

Parameter	Symbol	Pin name	Condition	Value			Unit	Remarks
				Min	Typ	Max		
Resolution	—	—	—	—	8	—	bit	
Differential linearity error	—	—		—	—	$\pm 0.5$	LSB	
Conversion time	—	—		—	0.45	—	$\mu\text{s}$	*
Analog output impedance	—	—		—	2.9	3.8	$\text{k}\Omega$	
Power supply current	$I_{DVR}$	$AV_{CC}$		—	160	920	$\mu\text{A}$	
	$I_{DVRS}$			—	0.1	—	$\mu\text{A}$	D/A stops

\* : With load capacitance 20 pF.

# MB90820 Series

## 9. Flash Memory Program/Erase Characteristics

Parameter	Condition	Value			Unit	Remarks
		Min	Typ	Max		
Sector erase time	T <sub>A</sub> = +25 °C V <sub>CC</sub> = 5.0 V	—	1	15	s	Excludes programming prior to erasure
Chip erase time		—	9	—	s	Excludes programming prior to erasure
Word (16 bit width) programing time		—	16	3,600	μs	Except for the overhead time of the system
Program/Erase cycle	—	10,000	—	—	cycle	
Flash data retention time	Average T <sub>A</sub> = +85 °C	20	—	—	year	*

\* : This value comes from the technology qualification (using Arrhenius equation to translate high temperature measurements into normalized value at + 85 °C) .

## ■ ORDERING INFORMATION

Part number	Package	Remarks
MB90F823APFV MB90F822APFV MB90822PFV MB90823PFV	80-pin Plastic LQFP (FPT-80P-M05)	
MB90F823APFM MB90F822APFM MB90822PFM MB90823PFM	80-pin Plastic LQFP (FPT-80P-M11)	
MB90F823APF MB90F822APF MB90822PF MB90823PF	80-pin Plastic QFP (FPT-80P-M06)	



## ■ PACKAGE DIMENSIONS

80-pin plastic QFP  
(FPT-80P-M06)

Note 1) \* : These dimensions do not include resin protrusion.  
 Note 2) Pins width and pins thickness include plating thickness.  
 Note 3) Pins width do not include tie bar cutting remainder.

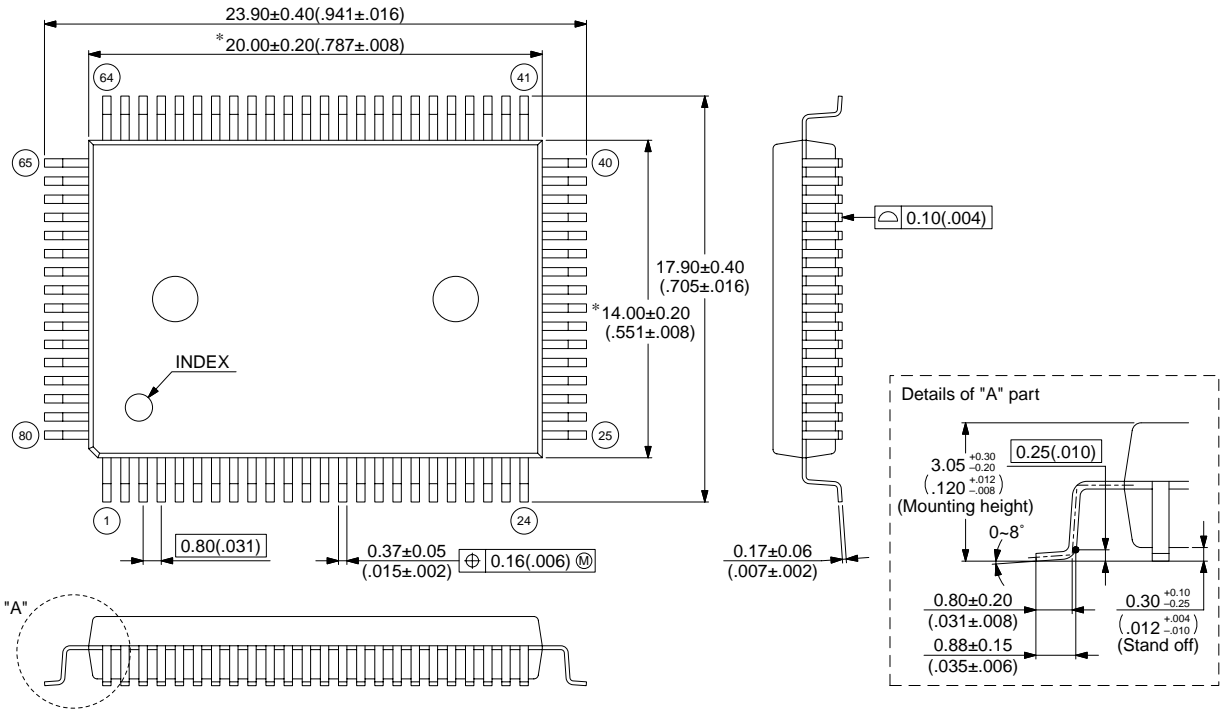

© 2002 FUJITSU LIMITED F80010S-c-6-5

Dimensions in mm (inches)

Note : The values in parentheses are reference values.

(Continued)

# MB90820 Series

80-pin plastic LQFP  
(FPT-80P-M11)

Note 1) \* : These dimensions do not include resin protrusion.  
 Note 2) Pins width and pins thickness include plating thickness.  
 Note 3) Pins width do not include tie bar cutting remainder.

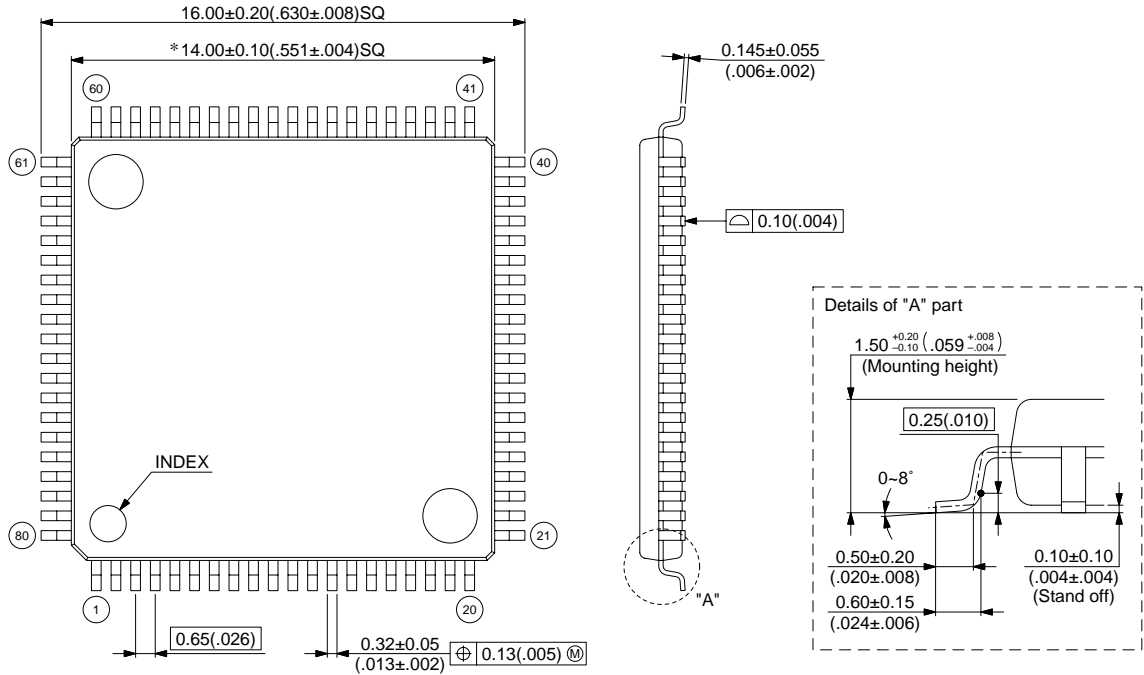

© 2003 FUJITSU LIMITED F80016S-c-3-6

Dimensions in mm (inches)

Note : The values in parentheses are reference values.

(Continued)

# MB90820 Series

(Continued)

80-pin plastic LQFP  
(FPT-80P-M05)

Note 1) \* : These dimensions do not include resin protrusion.  
 Note 2) Pins width and pins thickness include plating thickness.  
 Note 3) Pins width do not include tie bar cutting remainder.

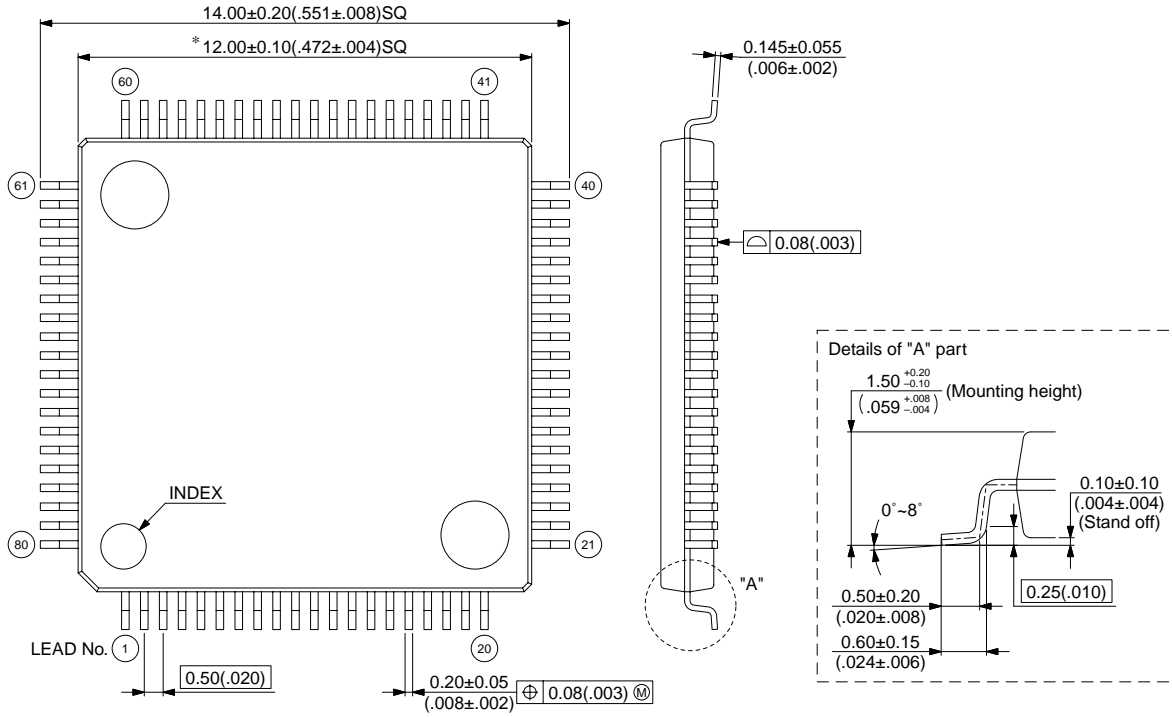

© 2003 FUJITSU LIMITED F80008S-c-4-8

Dimensions in mm (inches)

Note : The values in parentheses are reference values.

# MB90820 Series

The information for microcontroller supports is shown in the following homepage.  
<http://www.fujitsu.com/global/services/microelectronics/product/micom/support/index.html>

## FUJITSU LIMITED

All Rights Reserved.

The contents of this document are subject to change without notice. Customers are advised to consult with FUJITSU sales representatives before ordering.

The information, such as descriptions of function and application circuit examples, in this document are presented solely for the purpose of reference to show examples of operations and uses of Fujitsu semiconductor device; Fujitsu does not warrant proper operation of the device with respect to use based on such information. When you develop equipment incorporating the device based on such information, you must assume any responsibility arising out of such use of the information. Fujitsu assumes no liability for any damages whatsoever arising out of the use of the information.

Any information in this document, including descriptions of function and schematic diagrams, shall not be construed as license of the use or exercise of any intellectual property right, such as patent right or copyright, or any other right of Fujitsu or any third party or does Fujitsu warrant non-infringement of any third-party's intellectual property right or other right by using such information. Fujitsu assumes no liability for any infringement of the intellectual property rights or other rights of third parties which would result from the use of information contained herein.

The products described in this document are designed, developed and manufactured as contemplated for general use, including without limitation, ordinary industrial use, general office use, personal use, and household use, but are not designed, developed and manufactured as contemplated (1) for use accompanying fatal risks or dangers that, unless extremely high safety is secured, could have a serious effect to the public, and could lead directly to death, personal injury, severe physical damage or other loss (i.e., nuclear reaction control in nuclear facility, aircraft flight control, air traffic control, mass transport control, medical life support system, missile launch control in weapon system), or (2) for use requiring extremely high reliability (i.e., submersible repeater and artificial satellite).

Please note that Fujitsu will not be liable against you and/or any third party for any claims or damages arising in connection with above-mentioned uses of the products.

Any semiconductor devices have an inherent chance of failure. You must protect against injury, damage or loss from such failures by incorporating safety design measures into your facility and equipment such as redundancy, fire protection, and prevention of over-current levels and other abnormal operating conditions.

If any products described in this document represent goods or technologies subject to certain restrictions on export under the Foreign Exchange and Foreign Trade Law of Japan, the prior authorization by Japanese government will be required for export of those products from Japan.