

FEATURES

- Medical Application
- Low Cost, High Reliability
- Compact Size, Light Weight
- 100% Full Load Burn-In Test
- Universal AC Input / Full Range
- UL2601-1, EN60601-1 Approved
- Built-In EMI Filter, Low Ripple Noise
- High Efficiency, Low Working Temperature
- Protections: Short Circuit /Overload /Over Voltage



SPECIFICATIONS: PSMPS65 Series

All specifications are based on 25°C, Nominal Input Voltage, and Maximum Output Current unless otherwise noted.
We reserve the right to change specifications based on technological advances.

INPUT SPECIFICATIONS

Input Voltage	90 – 264VAC (127 – 370VDC)
Input Frequency	47 to 440Hz
AC Current (typical)	1.6A @ 115VAC / 0.9A @ 230VAC
Inrush Current	Cold start 15A @ 115VAC; 30A @ 230VAC
Leakage Current	Less than 0.3mA @ 264VAC

OUTPUT SPECIFICATIONS

Output Voltage	See Table
Voltage Tolerance	±2.0% typical
Output Adjustment Range	±10% rated output load
Output Power	72W max with 18CFM minimum forced air flow
Line Regulation	±1%
Load Regulation	±2% typical
Output Current	See Table
Ripple & Noise (20MHz BW)	100mVp-p typical
Setup, Rise Time	800ms and 30ms @ 230VAC and full load / 800ms and 30ms @ 115VAC and full load
Hold-Up Time	50ms @ 230VAC and full load / 16ms @ 115VAC and full load.
Temperature Coefficient	±0.04%/°C (0~50°C)

PROTECTION

Over Voltage Protection	CH.1: 115~135% rated output voltage
Overload Protection	73~105W hiccup mode, auto-recovery

GENERAL SPECIFICATIONS

Switching Frequency (fixed)	45KHz
Efficiency	Up to 80%
Isolation Voltage (Input to Output)	4000VAC for 1 min.
Isolation Voltage (Input to Field Ground)	1500VAC for 1 min.
Isolation Resistance (Input to Output)	100MΩ / 500VDC

ENVIRONMENTAL SPECIFICATIONS

Operating Temperature	-10°C to +60°C (refer to derating curve)
Storage Temperature	-20°C to +85°C
Operating Humidity (non-condensing)	20% to 90% RH
Vibration	10~500Hz, 2G 10min./1cycle, Period for 60 minutes each along X, Y, and Z axes.
MTBF	359,700 hours min. (According to MIL-HDBK-217) at 25°C

PHYSICAL SPECIFICATIONS

Weight	280g
Dimensions	127(L) x 76(W) x 42(H) mm

SAFETY & EMC

Safety Standards	UL2601-1, TUV EN60601-1, IEC601-1 Approved
EMC Standards	EN55011 class B, EN61000-4-2,3,4,5,6,8,11, EN61000-3-2,3, EN60601-1-2, ENV50204

OUTPUT VOLTAGE / CURRENT RATING CHART

Model	Input Voltage	Output Voltage	Output Current Range	Output Current	Ripple & Noise	Rated Output Power
PSMPS65-3.3	90~264 VAC (127~370 VDC)	3.3 VDC	0 – 15.2A	12A	80mVp-p	39.6W
PSMPS65-5		5 VDC	0 – 13.8A	12A	100mVp-p	60W
PSMPS65-7.5		7.5 VDC	0 – 9.6A	8A	100mVp-p	60W
PSMPS65-12		12 VDC	0 – 6A	5.2A	100mVp-p	62.4W
PSMPS65-13.5		13.5 VDC	0 – 5.4A	4.7A	100mVp-p	63.5W
PSMPS65-15		15 VDC	0 – 4.8A	4.2A	100mVp-p	63W
PSMPS65-24		24 VDC	0 – 3A	2.7A	100mVp-p	64.8W
PSMPS65-27		27 VDC	0 – 2.7A	2.4A	100mVp-p	64.8W
PSMPS65-48		48 VDC	0 – 1.5A	1.35A	100mVp-p	64.8W

NOTES

1. All parameters are specified at 230VAC input, rated load, 25°C ambient.
2. Tolerances include set up tolerance, line regulation, load regulation.
3. Line regulation is measured from low line to high line at rated load.
4. Mounting holes M1 and M2 should be grounded for EMI purposes.
5. Ripple & noise are measured at 20MHz by using a 12" twisted pair terminated with a 0.1uF & 47uF capacitor.

BLOCK DIAGRAM

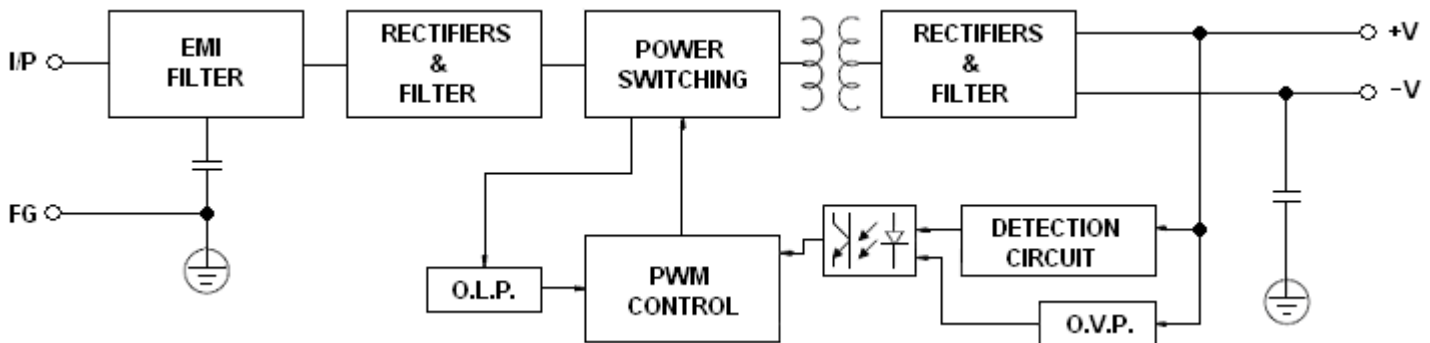

DERATING CURVE

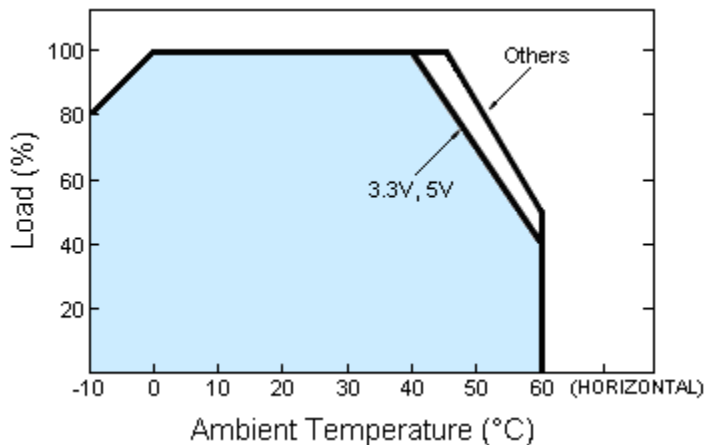

STATIC CHARACTERISTICS

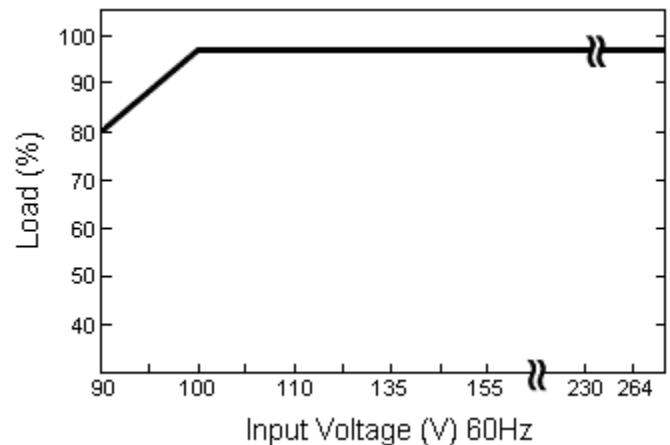

MECHANICAL DRAWING

Unit: mm

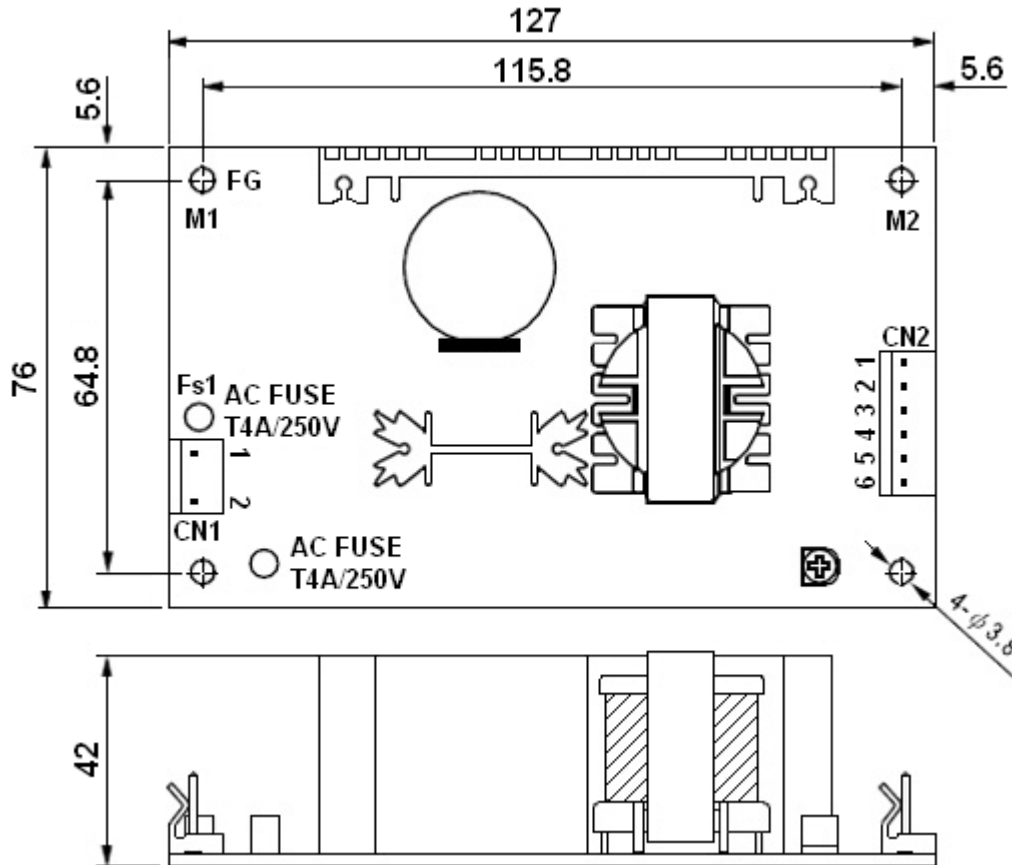

AC Input Connector (CN1): Molex 5277-02 or equivalent

Pin. No	Assignment	Mating Housing	Terminal
1	AC/N	Molex 5195 or equivalent	Molex 5194 or equivalent
2	AC/L		

DC Output Connector (CN2): Molex 5273-06 or equivalent

Pin No.	Assignment	Mating Housing	Terminal
1,2,3	+V	Molex 5195 or equivalent	Molex 5194 or equivalent
4,5,6	-V		