

SSD1805

Advance Information

132 x 68 STN
LCD Segment / Common Monochrome Driver with Controller

This document contains information on a new product. Specifications and information herein are subject to change without notice.

<http://www.solomon-systech.com>

SSD1805 Series | Rev 1.1 | P 1/52 | Jun 2004

Copyright © 2004 **Solomon Systech Limited**

TABLE OF CONTENTS

1	GENERAL DESCRIPTION.....	5
2	FEATURES.....	5
3	ORDERING INFORMATION	5
4	BLOCK DIAGRAM	6
5	DIE PAD FLOOR PLAN.....	7
6	PIN DESCRIPTION	11
7	FUNCTIONAL BLOCK DESCRIPTIONS	16
8	COMMAND TABLE.....	24
9	COMMAND DESCRIPTIONS.....	28
10	MAXIMUM RATINGS	36
11	DC CHARACTERISTICS	37
12	AC CHARACTERISTICS	39
13	APPLICATION EXAMPLES.....	46
14	PACKAGE INFORMATION	49

TABLE OF TABLES

Table 1 - Ordering Information	5
Table 2 - SSD1805 Series Bump Die Pad Coordinates (Bump center)	8
Table 3 - Arrangement of common at different multiplex modes	15
Table 4 - Data Bus selection Modes.....	17
Table 5 - Graphic Display Data RAM (GDDRAM) Address Map with Display Start Line set to 18h.....	18
Table 6 - Gain Setting.....	20
Table 7 - Temperature compensation coefficient.....	20
Table 8 - Command Table.....	24
Table 9 - Extended Command Table.....	26
Table 10 - Read Command Table	27
Table 11 - Automatic Address Increment	28
Table 12 - ROW pin assignment for COM signals for SSD1805 in an 68 MUX display	35
Table 13 - Maximum Ratings.....	36
Table 14 - DC Characteristics	37
Table 15 - AC Characteristics.....	39
Table 16 - Parallel 6800-series Interface Timing Characteristics.....	40
Table 17 - Parallel 6800-series Interface Timing Characteristics.....	41
Table 18 - Parallel 8080-series Interface Timing Characteristics.....	42
Table 19 - Parallel 8080-series Interface Timing Characteristics.....	43
Table 20 - 4-wires Serial Interface Timing Characteristics.....	44
Table 21 - 4-wires Serial Interface Timing Characteristics.....	45

TABLE OF FIGURES

Figure 1 - SSD1805 Block Diagram	6
Figure 2 - SSD1805 Die Pad Floor Plan	7
Figure 3 - Display Data Read with the insertion of dummy read	16
Figure 4 - SSD1805 Hardware configuration	19
Figure 5 - Contrast curve	21
Figure 6 - TC 0 oscillator typical frame frequency with variation in temperature.....	22
Figure 7 - LCD Driving Waveform	23
Figure 8 - Contrast Control Flow.....	29
Figure 9 - OTP programming circuitry	31
Figure 10 - Flow chart of OTP programming Procedure.....	32
Figure 11 - Parallel 6800-series Interface Timing Characteristics (P/S = H, C68/80 = H).....	40
Figure 12 - Parallel 6800-series Interface Timing Characteristics (P/S = H, C68/80 = H).....	41
Figure 13 - Parallel 8080-series Interface Timing Characteristics (P/S = H, C68/80 = L)	42
Figure 14 - Parallel 8080-series Interface Timing Characteristics (P/S = H, C68/80 = L)	43
Figure 15 - 4-wires Serial Interface Timing Characteristics (P/S = L, C68/80 = L).....	44
Figure 16 - 4-wires Serial Interface Timing Characteristics (P/S = L, C68/80 = L).....	45
Figure 17 - Application Example I (4-wires SPI mode)	46
Figure 18 - Application Example II (6800 PPI mode).....	47
Figure 19 - Applications notes for V_{DD}/V_{DDIO} connection.....	48
Figure 20 - SSD1805TR1 TAB Drawing (Copper view)	50
Figure 21 - SSD1805TR1 TAB Drawing (Detail view & pin assignment)	51

1 General Description

SSD1805 is a single-chip CMOS LCD driver with controller for dot-matrix graphic liquid crystal display system. SSD1805 consists of 200 high-voltage driving output pins for driving maximum 132 Segments, 68 Commons / 132 Segments, 64 Commons and 1 icon-driving Common / 132 Segments, 54 Commons and 1 icon-driving Common / 132 Segments, 32 Commons and 1 icon-driving Common. SSD1805 can also be switched among 32, 54, 64 or 68 display multiplex ratios by hardware pin selection.

SSD1805 consists of 132 x 68 bits Graphic Display Data RAM (GDDRAM). Data/Commands are sent from common MCU through 8-bit 6800-series / 8080-series compatible Parallel Interface or 4-wires Serial Peripheral Interface by software program selections.

SSD1805 embeds DC-DC Converter, On-Chip Oscillator and Bias Divider to reduce the number of external components. With the advance design, low power consumption, stable LCD operating voltage and flexible die package layout, SSD1805 is suitable for any portable battery-driven applications requiring long operation period with compact size.

2 FEATURES

- Power Supply: $V_{DD} = 1.8V - 3.6V$
 $V_{DDIO} = 1.8V - 3.6V$
 $V_{CI} = 1.8V - 3.6V$
- LCD Driving Output Voltage: $V_{LCD} = +12.5V$
- Low Current Sleep Mode
- Pin selectable 68/64/54/32 multiplex ratio configuration. Maximum display size:
 - 132 columns by 68 rows
 - 132 columns by 64 rows with one icon line
 - 132 columns by 54 rows with one icon line
 - 132 columns by 32 rows with one icon line
- 8-bit 6800-series / 8080-series Parallel Interface, 4-wires Serial Peripheral Interface
- On-Chip 132 X 68 = 8976 bits Graphic Display Data RAM
- Column Re-mapping and RAM Page scan direction control
- Vertical Scrolling by Common
- On-Chip Voltage Generator or External LCD Driving Power Supply Selectable
- Pin selectable 2X/3X/4X/5X On-Chip DC-DC Converter with internal flying capacitors.
- 64 Levels Internal Contrast Control
- Programmable LCD Driving Voltage Temperature Compensation Coefficients
- On-Chip Bias Divider with internal compensation capacitors (except V_{OUT})
- Programmable multiplex ratio: 1/9 to 1/68
- Programmable bias ratio: 1/4, 1/5, 1/6, 1/7, 1/8, 1/9
- Display Offset Control
- Non-Volatile Memory (OTP) for calibration

3 ORDERING INFORMATION

Ordering Part Number	SEG	COM	Package Form	Reference	Remark
SSD1805Z	132	64/54/32 + 1 icon or 68	Gold Bump Die	Figure 2 on Page 7	-
SSD1805TR1	132	64 + 1 icon	TAB	Figure 20 on page 50	-

Table 1 - Ordering Information

4 BLOCK DIAGRAM

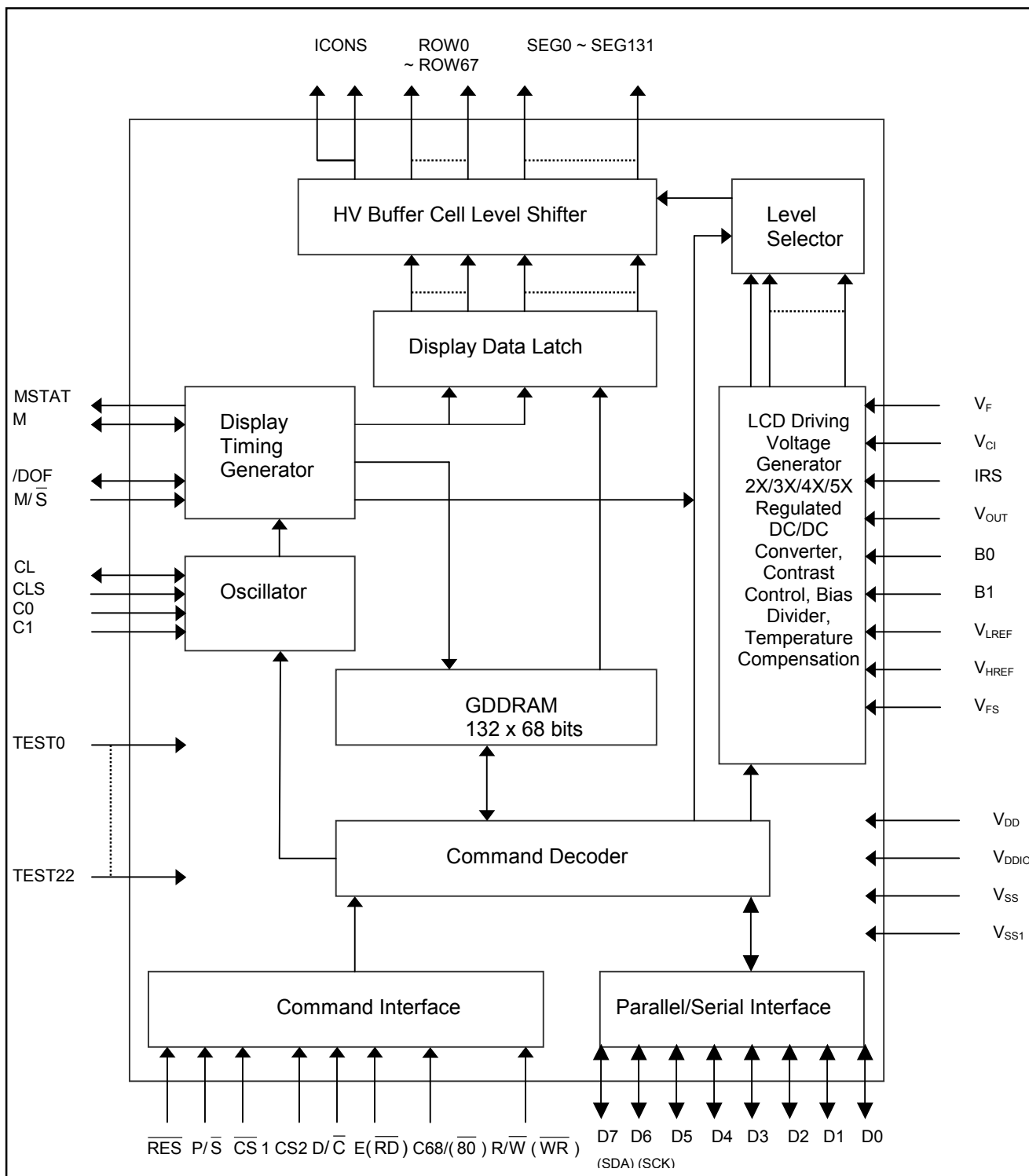
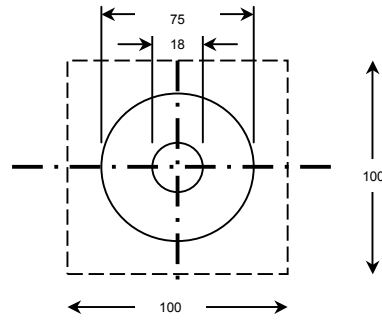
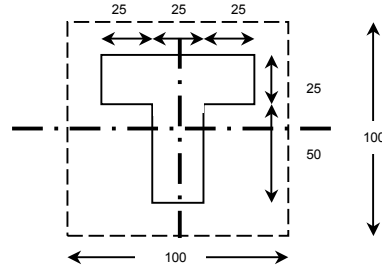
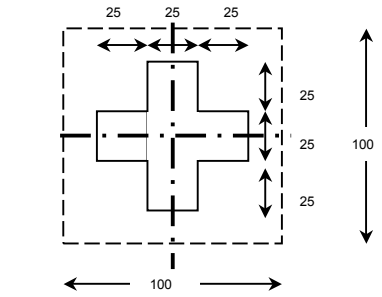
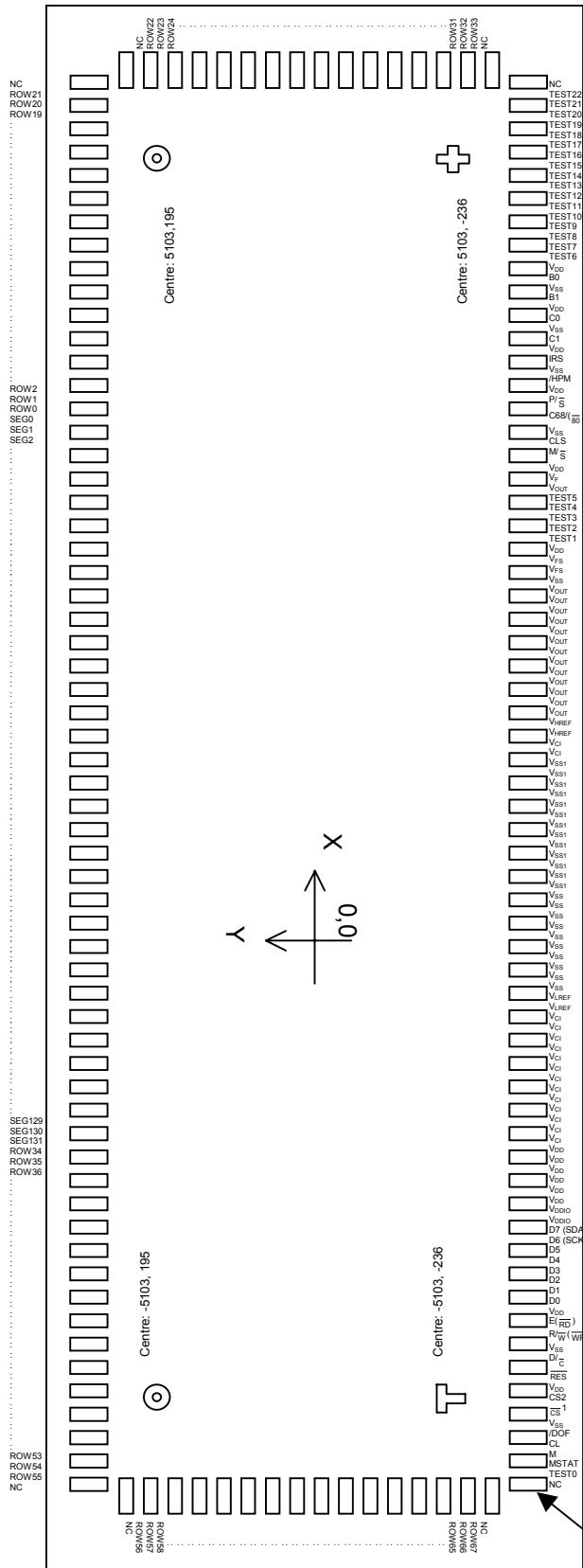

Figure 1 - SSD1805 Block Diagram

5 DIE PAD FLOOR PLAN



Die Size	11.06 X 1.21	mm^2
Die Thickness	533±25	μm
Typical Bump Height	18	μm
Bump Co-planarity (within die)	< 3	μm

Figure 2 - SSD1805 Die Pad Floor Plan

Table 2 - SSD1805 Series Bump Die Pad Coordinates (Bump center)

Pad #	Signal	X-pos	Y-pos	Pad #	Signal	X-pos	Y-pos	Pad #	Signal	X-pos	Y-pos
1	NC	-5167.10	-448.50	51	V _{SS}	-1297.10	-448.50	101	CLS	2517.90	-448.50
2	TEST0	-5035.80	-448.50	52	V _{SS}	-1220.80	-448.50	102	V _{SS}	2594.20	-448.50
3	MSTAT	-4959.50	-448.50	53	V _{SS}	-1144.50	-448.50	103	C68/($\overline{80}$)	2670.50	-448.50
4	M	-4883.20	-448.50	54	V _{SS}	-1068.20	-448.50	104	P/ \overline{S}	2746.80	-448.50
5	CL	-4806.90	-448.50	55	V _{SS}	-991.90	-448.50	105	V _{DD}	2823.10	-448.50
6	/DOF	-4730.60	-448.50	56	V _{SS}	-915.60	-448.50	106	/HPM	2899.40	-448.50
7	V _{SS}	-4654.30	-448.50	57	V _{SS}	-839.30	-448.50	107	V _{SS}	2975.70	-448.50
8	\overline{CS}_1	-4578.00	-448.50	58	V _{SS1}	-763.00	-448.50	108	IRS	3052.00	-448.50
9	CS2	-4501.70	-448.50	59	V _{SS1}	-686.70	-448.50	109	V _{DD}	3128.30	-448.50
10	V _{DD}	-4425.40	-448.50	60	V _{SS1}	-610.40	-448.50	110	C1	3204.60	-448.50
11	\overline{RES}	-4349.10	-448.50	61	V _{SS1}	-534.10	-448.50	111	V _{SS}	3280.90	-448.50
12	D/ \overline{C}	-4272.80	-448.50	62	V _{SS1}	-457.80	-448.50	112	C0	3357.20	-448.50
13	V _{SS}	-4196.50	-448.50	63	V _{SS1}	-381.50	-448.50	113	V _{DD}	3433.50	-448.50
14	R/ \overline{W} (WR)	-4120.20	-448.50	64	V _{SS1}	-305.20	-448.50	114	B1	3509.80	-448.50
15	E(\overline{RD})	-4043.90	-448.50	65	V _{SS1}	-228.90	-448.50	115	V _{SS}	3586.10	-448.50
16	V _{DD}	-3967.60	-448.50	66	V _{SS1}	-152.60	-448.50	116	B0	3662.40	-448.50
17	D0	-3891.30	-448.50	67	V _{SS1}	-76.30	-448.50	117	V _{DD}	3738.70	-448.50
18	D1	-3815.00	-448.50	68	V _{SS1}	0.00	-448.50	118	TEST6	3815.00	-448.50
19	D2	-3738.70	-448.50	69	V _{SS1}	76.30	-448.50	119	TEST7	3891.30	-448.50
20	D3	-3662.40	-448.50	70	V _{SS1}	152.60	-448.50	120	TEST8	3967.60	-448.50
21	D4	-3586.10	-448.50	71	V _{Cl}	228.90	-448.50	121	TEST9	4043.90	-448.50
22	D5	-3509.80	-448.50	72	V _{Cl}	305.20	-448.50	122	TEST10	4120.20	-448.50
23	D6 (SCK)	-3433.50	-448.50	73	V _{HREF}	381.50	-448.50	123	TEST11	4196.50	-448.50
24	D7 (SDA)	-3357.20	-448.50	74	V _{HREF}	457.80	-448.50	124	TEST12	4272.80	-448.50
25	V _{DDIO}	-3280.90	-448.50	75	V _{OUT}	534.10	-448.50	125	TEST13	4349.10	-448.50
26	V _{DDIO}	-3204.60	-448.50	76	V _{OUT}	610.40	-448.50	126	TEST14	4425.40	-448.50
27	V _{DD}	-3128.30	-448.50	77	V _{OUT}	686.70	-448.50	127	TEST15	4501.70	-448.50
28	V _{DD}	-3052.00	-448.50	78	V _{OUT}	763.00	-448.50	128	TEST16	4578.00	-448.50
29	V _{DD}	-2975.70	-448.50	79	V _{OUT}	839.30	-448.50	129	TEST17	4654.30	-448.50
30	V _{DD}	-2899.40	-448.50	80	V _{OUT}	915.60	-448.50	130	TEST18	4730.60	-448.50
31	V _{DD}	-2823.10	-448.50	81	V _{OUT}	991.90	-448.50	131	TEST19	4806.90	-448.50
32	V _{DD}	-2746.80	-448.50	82	V _{OUT}	1068.20	-448.50	132	TEST20	4883.20	-448.50
33	V _{Cl}	-2670.50	-448.50	83	V _{OUT}	1144.50	-448.50	133	TEST21	4959.50	-448.50
34	V _{Cl}	-2594.20	-448.50	84	V _{OUT}	1220.80	-448.50	134	TEST22	5035.80	-448.50
35	V _{Cl}	-2517.90	-448.50	85	V _{OUT}	1297.10	-448.50	135	NC	5167.10	-448.50
36	V _{Cl}	-2441.60	-448.50	86	V _{OUT}	1373.40	-448.50	136	NC	5372.00	-376.00
37	V _{Cl}	-2365.30	-448.50	87	V _{OUT}	1449.70	-448.50	137	ROW33	5372.00	-318.00
38	V _{Cl}	-2289.00	-448.50	88	V _{SS}	1526.00	-448.50	138	ROW32	5372.00	-260.00
39	V _{Cl}	-2212.70	-448.50	89	V _{FS}	1602.30	-448.50	139	ROW31	5372.00	-202.00
40	V _{Cl}	-2136.40	-448.50	90	V _{FS}	1678.60	-448.50	140	ROW30	5372.00	-144.00
41	V _{Cl}	-2060.10	-448.50	91	V _{DD}	1754.90	-448.50	141	ROW29	5372.00	-86.00
42	V _{Cl}	-1983.80	-448.50	92	TEST1	1831.20	-448.50	142	ROW28	5372.00	-28.00
43	V _{Cl}	-1907.50	-448.50	93	TEST2	1907.50	-448.50	143	ROW27	5372.00	30.00
44	V _{Cl}	-1831.20	-448.50	94	TEST3	1983.80	-448.50	144	ROW26	5372.00	88.00
45	V _{Cl}	-1754.90	-448.50	95	TEST4	2060.10	-448.50	145	ROW25	5372.00	146.00
46	V _{LREF}	-1678.60	-448.50	96	TEST5	2136.40	-448.50	146	ROW24	5372.00	204.00
47	V _{LREF}	-1602.30	-448.50	97	V _{OUT}	2212.70	-448.50	147	ROW23	5372.00	262.00
48	V _{SS}	-1526.00	-448.50	98	V _F	2289.00	-448.50	148	ROW22	5372.00	320.00
49	V _{SS}	-1449.70	-448.50	99	V _{DD}	2365.30	-448.50	149	NC	5372.00	378.00
50	V _{SS}	-1373.40	-448.50	100	M/ \overline{S}	2441.60	-448.50	150	NC	5141.25	448.50

Pad #	Signal	X-pos	Y-pos	Pad #	Signal	X-pos	Y-pos	Pad #	Signal	X-pos	Y-pos
151	ROW21	5083.25	448.50	201	SEG28	2175.00	448.50	251	SEG78	-725.00	448.50
152	ROW20	5025.25	448.50	202	SEG29	2117.00	448.50	252	SEG79	-783.00	448.50
153	ROW19	4967.25	448.50	203	SEG30	2059.00	448.50	253	SEG80	-841.00	448.50
154	ROW18	4909.25	448.50	204	SEG31	2001.00	448.50	254	SEG81	-899.00	448.50
155	ROW17	4851.25	448.50	205	SEG32	1943.00	448.50	255	SEG82	-957.00	448.50
156	ROW16	4793.25	448.50	206	SEG33	1885.00	448.50	256	SEG83	-1015.00	448.50
157	ROW15	4735.25	448.50	207	SEG34	1827.00	448.50	257	SEG84	-1073.00	448.50
158	ROW14	4677.25	448.50	208	SEG35	1769.00	448.50	258	SEG85	-1131.00	448.50
159	ROW13	4619.25	448.50	209	SEG36	1711.00	448.50	259	SEG86	-1189.00	448.50
160	ROW12	4561.25	448.50	210	SEG37	1653.00	448.50	260	SEG87	-1247.00	448.50
161	ROW11	4503.25	448.50	211	SEG38	1595.00	448.50	261	SEG88	-1305.00	448.50
162	ROW10	4445.25	448.50	212	SEG39	1537.00	448.50	262	SEG89	-1363.00	448.50
163	ROW9	4387.25	448.50	213	SEG40	1479.00	448.50	263	SEG90	-1421.00	448.50
164	ROW8	4329.25	448.50	214	SEG41	1421.00	448.50	264	SEG91	-1479.00	448.50
165	ROW7	4271.25	448.50	215	SEG42	1363.00	448.50	265	SEG92	-1537.00	448.50
166	ROW6	4213.25	448.50	216	SEG43	1305.00	448.50	266	SEG93	-1595.00	448.50
167	ROW5	4155.25	448.50	217	SEG44	1247.00	448.50	267	SEG94	-1653.00	448.50
168	ROW4	4097.25	448.50	218	SEG45	1189.00	448.50	268	SEG95	-1711.00	448.50
169	ROW3	4039.25	448.50	219	SEG46	1131.00	448.50	269	SEG96	-1769.00	448.50
170	ROW2	3981.25	448.50	220	SEG47	1073.00	448.50	270	SEG97	-1827.00	448.50
171	ROW1	3923.25	448.50	221	SEG48	1015.00	448.50	271	SEG98	-1885.00	448.50
172	ROW0	3865.25	448.50	222	SEG49	957.00	448.50	272	SEG99	-1943.00	448.50
173	SEG0	3799.00	448.50	223	SEG50	899.00	448.50	273	SEG100	-2001.00	448.50
174	SEG1	3741.00	448.50	224	SEG51	841.00	448.50	274	SEG101	-2059.00	448.50
175	SEG2	3683.00	448.50	225	SEG52	783.00	448.50	275	SEG102	-2117.00	448.50
176	SEG3	3625.00	448.50	226	SEG53	725.00	448.50	276	SEG103	-2175.00	448.50
177	SEG4	3567.00	448.50	227	SEG54	667.00	448.50	277	SEG104	-2233.00	448.50
178	SEG5	3509.00	448.50	228	SEG55	609.00	448.50	278	SEG105	-2291.00	448.50
179	SEG6	3451.00	448.50	229	SEG56	551.00	448.50	279	SEG106	-2349.00	448.50
180	SEG7	3393.00	448.50	230	SEG57	493.00	448.50	280	SEG107	-2407.00	448.50
181	SEG8	3335.00	448.50	231	SEG58	435.00	448.50	281	SEG108	-2465.00	448.50
182	SEG9	3277.00	448.50	232	SEG59	377.00	448.50	282	SEG109	-2523.00	448.50
183	SEG10	3219.00	448.50	233	SEG60	319.00	448.50	283	SEG110	-2581.00	448.50
184	SEG11	3161.00	448.50	234	SEG61	261.00	448.50	284	SEG111	-2639.00	448.50
185	SEG12	3103.00	448.50	235	SEG62	203.00	448.50	285	SEG112	-2697.00	448.50
186	SEG13	3045.00	448.50	236	SEG63	145.00	448.50	286	SEG113	-2755.00	448.50
187	SEG14	2987.00	448.50	237	SEG64	87.00	448.50	287	SEG114	-2813.00	448.50
188	SEG15	2929.00	448.50	238	SEG65	29.00	448.50	288	SEG115	-2871.00	448.50
189	SEG16	2871.00	448.50	239	SEG66	-29.00	448.50	289	SEG116	-2929.00	448.50
190	SEG17	2813.00	448.50	240	SEG67	-87.00	448.50	290	SEG117	-2987.00	448.50
191	SEG18	2755.00	448.50	241	SEG68	-145.00	448.50	291	SEG118	-3045.00	448.50
192	SEG19	2697.00	448.50	242	SEG69	-203.00	448.50	292	SEG119	-3103.00	448.50
193	SEG20	2639.00	448.50	243	SEG70	-261.00	448.50	293	SEG120	-3161.00	448.50
194	SEG21	2581.00	448.50	244	SEG71	-319.00	448.50	294	SEG121	-3219.00	448.50
195	SEG22	2523.00	448.50	245	SEG72	-377.00	448.50	295	SEG122	-3277.00	448.50
196	SEG23	2465.00	448.50	246	SEG73	-435.00	448.50	296	SEG123	-3335.00	448.50
197	SEG24	2407.00	448.50	247	SEG74	-493.00	448.50	297	SEG124	-3393.00	448.50
198	SEG25	2349.00	448.50	248	SEG75	-551.00	448.50	298	SEG125	-3451.00	448.50
199	SEG26	2291.00	448.50	249	SEG76	-609.00	448.50	299	SEG126	-3509.00	448.50
200	SEG27	2233.00	448.50	250	SEG77	-667.00	448.50	300	SEG127	-3567.00	448.50

Pad #	Signal	X-pos	Y-pos
301	SEG128	-3625.00	448.50
302	SEG129	-3683.00	448.50
303	SEG130	-3741.00	448.50
304	SEG131	-3799.00	448.50
305	ROW34	-3865.25	448.50
306	ROW35	-3923.25	448.50
307	ROW36	-3981.25	448.50
308	ROW37	-4039.25	448.50
309	ROW38	-4097.25	448.50
310	ROW39	-4155.25	448.50
311	ROW40	-4213.25	448.50
312	ROW41	-4271.25	448.50
313	ROW42	-4329.25	448.50
314	ROW43	-4387.25	448.50
315	ROW44	-4445.25	448.50
316	ROW45	-4503.25	448.50
317	ROW46	-4561.25	448.50
318	ROW47	-4619.25	448.50
319	ROW48	-4677.25	448.50
320	ROW49	-4735.25	448.50
321	ROW50	-4793.25	448.50
322	ROW51	-4851.25	448.50
323	ROW52	-4909.25	448.50
324	ROW53	-4967.25	448.50
325	ROW54	-5025.25	448.50
326	ROW55	-5083.25	448.50
327	NC	-5141.25	448.50
328	NC	-5372.00	378.00
329	ROW56	-5372.00	320.00
330	ROW57	-5372.00	262.00
331	ROW58	-5372.00	204.00
332	ROW59	-5372.00	146.00
333	ROW60	-5372.00	88.00
334	ROW61	-5372.00	30.00
335	ROW62	-5372.00	-28.00
336	ROW63	-5372.00	-86.00
337	ROW64	-5372.00	-144.00
338	ROW65	-5372.00	-202.00
339	ROW66	-5372.00	-260.00
340	ROW67	-5372.00	-318.00
341	NC	-5372.00	-376.00

Bump Size

PAD#	X [um]	Y [um]	Pad pitch [um] (Min)
Pad 1	56	92	131.3
Pad 2 - 134	56	92	76.3
Pad 135	56	92	131.3
Pad 136 - 149	89	36	58
Pad 150 - 327	36	89	58
Pad 328 - 341	89	36	58

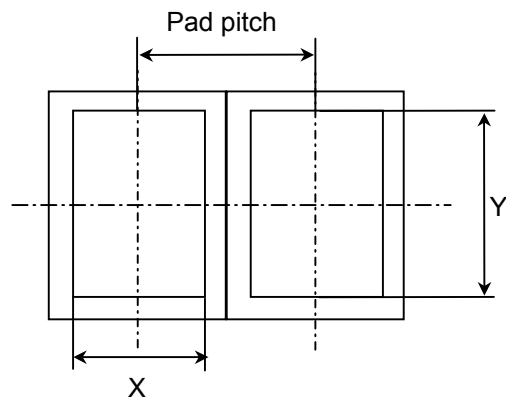

6 PIN DESCRIPTION

6.1 MSTAT

This pin is the static indicator driving output. The frame signal output pin, M, should be used as the back plane signal for the static indicator. The duration of overlapping could be programmable. See Extended Command Table for details.

6.2 M

This pin is the frame signal input/output. In master mode, the pin supplies frame signal to slave devices while in slave mode, the pin receives frame signal from the master device.

6.3 CL

This pin is the display clock input/output. In master mode with internal oscillator enabled (CLS pin pulled high), this pin supplies display clock signal to slave devices. In slave mode or when internal oscillator is disabled, the pin receives display clock signal from the master device or external clock source.

6.4 /DOF

This pin is display blanking control between master and slave devices. In master mode, this pin supplies on/off signal to slave devices. In slave mode, this pin receives on/off signal from the master device.

6.5 $\overline{\text{CS}}1, \text{CS}2$

These pins are the chip select inputs. The chip is enabled for MCU communication only when both $\overline{\text{CS}}1$ is pulled low and CS2 is pulled high.

6.6 $\overline{\text{RES}}$

This pin is the reset signal input. Initialization of the chip is started once this pin is pulled low. Minimum pulse width for reset sequence is 20us.

6.7 $\text{D}/\overline{\text{C}}$

This pin is Data/Command control pin. When the pin is pulled high, the data at D7 - D0 is treated as display data. When the pin is pulled low, the data at D7 - D0 will be transferred to the command register.

6.8 $\text{R}/\overline{\text{W}}$ ($\overline{\text{WR}}$)

This pin is MCU interface input. When 6800 interface mode is selected, this pin will be used as Read/Write ($\text{R}/\overline{\text{W}}$) selection input. Read mode will be carried out when this pin is pulled high and write mode when low. When 8080 interface mode is selected, this pin is the Write ($\overline{\text{WR}}$) control signal input. Data write operation is initiated when this pin is pulled low and the chip is selected. When serial interface mode is selected, this pin must be pulled low.

6.9 $\text{E}(\overline{\text{RD}})$

This pin is MCU interface input. When 6800 interface mode is selected, this pin will be used as the Enable (E) signal. Read/write operation is initiated when this pin is pulled high and the chip is selected. When 8080 interface mode is selected, this pin is the Read ($\overline{\text{RD}}$) control signal input. Data read operation is initiated when this pin is pulled low and the chip is selected. When serial interface mode is selected, this pin must be pulled high.

6.10 D7 - D0

These pins are the 8-bit bi-directional data bus in parallel interface mode. D7 is the MSB while D0 is the LSB. When serial mode is selected, D7 is the serial data input (SDA) and D6 is the serial clock input (SCK).

6.11 V_{DDIO}

This pin is the system power supply pin of bus IO buffer. Please refer to figure 19 on page 48 for connection example.

6.12 V_{DD}

This pin is the system power supply pin of the logic block.

6.13 V_{CI}

Reference voltage input for internal DC-DC converter. The voltage of generated V_{OUT} equals to the multiple factor (2X, 3X, 4X or 5X) times V_{CI} with respect to V_{SS1} .

Note: Voltage at this input pin must be larger than or equal to V_{DD} .

6.14 V_{SS}

The V_{SS} is the ground reference of the system.

6.15 V_{SS1}

Reference voltage input for internal DC-DC converter. The voltage of generated V_{OUT} equals to the multiple factor (2X, 3X, 4X or 5X) times V_{CI} with respect to V_{SS1} .

Note: Voltage at this input pin must be equal to V_{SS} .

6.16 V_{LREF}

This pin is the ground of internal operation amplifier. In normal power mode, it must connect to V_{SS} . In low power mode, it must connect to V_{CI} . Please refer to figure 19 on page 48 for the detail.

6.17 V_{HREF}

This pin is the power supply pin of the internal operation amplifier. It must connect to V_{OUT} .

6.18 V_{OUT}

This is the most positive voltage supply pin of the chip. It can be supplied externally or generated by the internal DC-DC converter. If the internal DC-DC converter generates the voltage level at V_{OUT} , the voltage level is used for internal referencing only. The voltage level at V_{OUT} pin is not used for driving external circuitry.

6.19 V_{FS}

This is an input pin to provide an external voltage reference for the internal voltage regulator. The function of this pin is only enabled for the External Input chip models which are required special ordering. For normal chip model, please leave this pin NC (No connection).

6.20 V_F

This pin is the input of the built-in voltage regulator for generating V_{OUT} . When external resistor network is selected (IRS pulled low) to generate the LCD driving level, V_{OUT} , two external resistors, R_1 and R_2 , should be connected between V_{SS} and V_F , and V_F and V_{OUT} , respectively (see application circuit diagrams).

6.21 M/\bar{S}

This pin is the master/slave mode selection input. When this pin is pulled high, master mode is selected, which CL, M, MSTAT and /DOF signals will be output for slave devices. When this pin is pulled low, slave mode is selected, which CL, M, /DOF are required to be input from master device. MSTAT will still be an output signal in slave mode.

6.22 CLS

This pin is the internal clock enable pin. When this pin is pulled high, internal clock is enabled. The internal clock will be disabled when it is pulled low, an external clock source must be input to CL pin for normal operation.

6.23 C68/ $\overline{80}$

This pin is MCU parallel interface selection input. When the pin is pulled high, 6800 series interface is selected and when the pin is pulled low, 8080 series interface is selected. If Serial Interface is selected ($\overline{P/S}$ pulled low), the setting of this pin is ignored, but it must be connected to a known logic (either high or low).

6.24 $\overline{P/S}$

This pin is serial/parallel interface selection input. When this pin is pulled high, parallel interface mode is selected. When it is pulled low, serial interface will be selected.

Note1: For serial mode, $\overline{R/W}$ (\overline{WR}) must be connected to V_{SS} . $\overline{E/(RD)}$ must be connected to V_{DD} . D0 to D5 and C68/80 can be connected to either V_{DD} or V_{SS} .

Note2: Read Back operation is only available in parallel mode.

6.25 \overline{HPM}

This pin is the control input of High Power Current Mode. The function of this pin is only enabled for High Power model, which required special ordering. For normal models, High Power Mode is disabled.

Note: This pin must be pulled to high. Leaving this pin floating is prohibited.

6.26 IRS

This is the input pin to enable the internal resistors network for the voltage regulator. When this pin is pulled high, the internal feedback resistors of the internal regulator for generating V_{OUT} will be enabled. When it is pulled low, external resistors, R_1 and R_2 , should be connected to V_{SS} and V_F , and V_F and V_{OUT} , respectively (see application circuit diagrams).

6.27 C1, C0

These pins are the Chip Mode Selection input. The chip mode is determined by multiplex ratio. Altogether there are four chip modes. Please see the following list for reference.

C1	C0	Chip Mode
0	0	32 MUX Mode
0	1	54 MUX Mode
1	0	64 MUX Mode
1	1	68 MUX Mode

Please refer to Table 3 on page 15 for detail description of common pins at different multiplex mode.

6.28 B1, B0

These pins are the Chip Mode Selection input. The chip mode is determined by default boosting level. Altogether there are four chip modes. Please see the following list for reference.

B1	B0	Chip Mode
0	0	3X as POR default
0	1	4X as POR default
1	0	5X as POR default
1	1	2X as POR default

5X, 4X, 3X or 2X booster level can be selected as POR default value of the device.

6.29 ROW0 to ROW67

These pins provide the Common driving signals to the LCD panel. See Table 3 on page 15 for the COM signal mapping in different multiplex mode of SSD1805. There are ICON pins on the chip when either 64 or 54 or 32 Mux mode is selected. The ICON pins are located at the COM 0 pin and COM 67 pin.

6.30 SEG0 to SEG131

These pins provide the LCD segment driving signals. The output voltage level of these pins is V_{SS} during sleep mode and standby mode.

6.31 TEST0

This pin is a test pin. It is recommended to connect to V_{SS} in normal operation.

6.32 TEST1 ~ TEST22

These pins are test pins. Nothing should be connected to these pins, nor they are connected together.

6.33 NC

These pins are NC/no connection pins. Nothing should be connected to these pins, nor they are connected together.

Command	C0 = 0; C1 = 0;	C0 = 1; C1 = 0;	C0 = 0; C1 = 1;	C0 = 1; C1 = 1;
Pin Name	32 Mux Mode	54 Mux Mode	64 Mux Mode	68 Mux Mode
ROW0	ICON	ICON	ICON	COM0
ROW1	Non-select	Non-select	Non-select	COM1
ROW2	Non-select	Non-select	COM0	COM2
ROW3	Non-select	Non-select	COM1	COM3
ROW4	Non-select	Non-select	COM2	COM4
ROW5	Non-select	Non-select	COM3	COM5
ROW6	Non-select	Non-select	COM4	COM6
ROW7	Non-select	COM0	COM5	COM7
ROW8	Non-select	COM1	COM6	COM8
ROW9	Non-select	COM2	COM7	COM9
ROW10	Non-select	COM3	COM8	COM10
ROW11	Non-select	COM4	COM9	COM11
ROW12	Non-select	COM5	COM10	COM12
ROW13	Non-select	COM6	COM11	COM13
ROW14	Non-select	COM7	COM12	COM14
ROW15	Non-select	COM8	COM13	COM15
ROW16	Non-select	COM9	COM14	COM16
ROW17	Non-select	COM10	COM15	COM17
ROW18	COM0	COM11	COM16	COM18
ROW19	COM1	COM12	COM17	COM19
ROW20	COM2	COM13	COM18	COM20
ROW21	COM3	COM14	COM19	COM21
ROW22	COM4	COM15	COM20	COM22
ROW23	COM5	COM16	COM21	COM23
ROW24	COM6	COM17	COM22	COM24
ROW25	COM7	COM18	COM23	COM25
ROW26	COM8	COM19	COM24	COM26
ROW27	COM9	COM20	COM25	COM27
ROW28	COM10	COM21	COM26	COM28
ROW29	COM11	COM22	COM27	COM29
ROW30	COM12	COM23	COM28	COM30
ROW31	COM13	COM24	COM29	COM31
ROW32	COM14	COM25	COM30	COM32
ROW33	COM15	COM26	COM31	COM33
ROW34	Non-select	Non-select	Non-select	COM34
ROW35	Non-select	Non-select	COM32	COM35
ROW36	Non-select	Non-select	COM33	COM36
ROW37	Non-select	Non-select	COM34	COM37
ROW38	Non-select	Non-select	COM35	COM38
ROW39	Non-select	Non-select	COM36	COM39
ROW40	Non-select	COM27	COM37	COM40
ROW41	Non-select	COM28	COM38	COM41
ROW42	Non-select	COM29	COM39	COM42
ROW43	Non-select	COM30	COM40	COM43
ROW44	Non-select	COM31	COM41	COM44
ROW45	Non-select	COM32	COM42	COM45
ROW46	Non-select	COM33	COM43	COM46
ROW47	Non-select	COM34	COM44	COM47
ROW48	Non-select	COM35	COM45	COM48
ROW49	Non-select	COM36	COM46	COM49
ROW50	Non-select	COM37	COM47	COM50
ROW51	COM16	COM38	COM48	COM51
ROW52	COM17	COM39	COM49	COM52
ROW53	COM18	COM40	COM50	COM53
ROW54	COM19	COM41	COM51	COM54
ROW55	COM20	COM42	COM52	COM55
ROW56	COM21	COM43	COM53	COM56
ROW57	COM22	COM44	COM54	COM57
ROW58	COM23	COM45	COM55	COM58
ROW59	COM24	COM46	COM56	COM59
ROW60	COM25	COM47	COM57	COM60
ROW61	COM26	COM48	COM58	COM61
ROW62	COM27	COM49	COM59	COM62
ROW63	COM28	COM50	COM60	COM63
ROW64	COM29	COM51	COM61	COM64
ROW65	COM30	COM52	COM62	COM65
ROW66	COM31	COM53	COM63	COM66
ROW67	ICON	ICON	ICON	COM67

Table 3 - Arrangement of common at different multiplex modes

Remarks: "Non-select" means no common signal will be selected to support those output ROW pins.

7 FUNCTIONAL BLOCK DESCRIPTIONS

7.1 Microprocessor Interface Logic

The Microprocessor Interface unit consists of three functional blocks for driving the 6800-series parallel interface, 8080-series parallel interface and 4-wires serial peripheral interface. The selection of different interfaces is done by P/ \overline{S} pin and C68/ $\overline{80}$ pin. Please refer to the pin descriptions on page 8.

a) MPU 6800-series Parallel Interface

The parallel interface consists of 8 bi-directional data pins (D7-D0), $\overline{R/W}$ (\overline{WR}), $\overline{D/C}$, $\overline{E(RD)}$, $\overline{CS1}$ and $\overline{CS2}$. $\overline{R/W}$ (\overline{WR}) input high indicates a read operation from the Graphic Display Data RAM (GDDRAM) or the status register. $\overline{R/W}$ (\overline{WR}) input Low indicates a write operation to Display Data RAM or Internal Command Registers depending on the status of $\overline{D/C}$ input. The $\overline{E(RD)}$ input serves as data latch signal (clock) when high provided that $\overline{CS1}$ and $\overline{CS2}$ are low and high respectively. Please refer to Figure 11 & 12 on page 40 & 41 for Parallel Interface Timing Diagram of 6800-series microprocessors. In order to match the operating frequency of the GDDRAM with that of the MCU, some pipeline processing is internally performed which requires the insertion of a dummy read before the first actual display data read. This is shown in Figure 3.

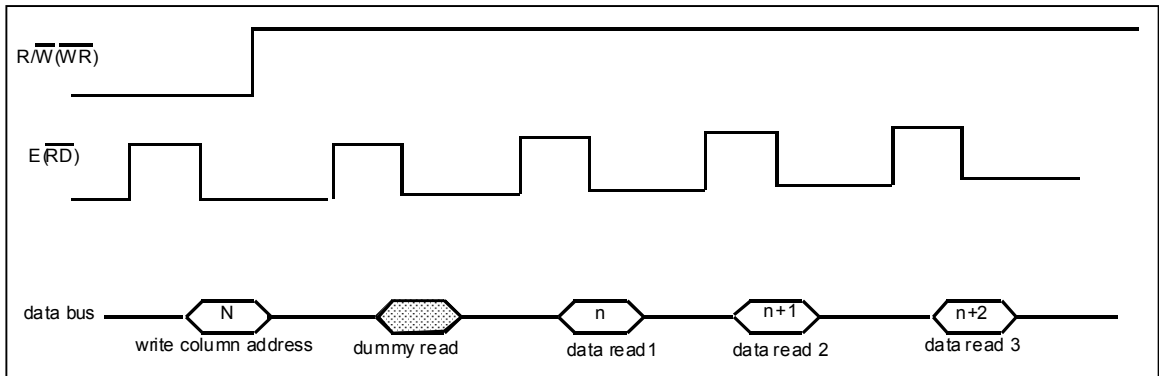

Figure 3 - Display Data Read with the insertion of dummy read

b) MPU 8080-series Parallel Interface

The parallel interface consists of 8 bi-directional data pins (D7-D0), $\overline{E(RD)}$, $\overline{R/W}$ (\overline{WR}), $\overline{D/C}$, $\overline{CS1}$ and $\overline{CS2}$. $\overline{E(RD)}$ input serves as data read latch signal (clock) when low provided that $\overline{CS1}$ and $\overline{CS2}$ are low and high respectively. Whether reading the display data from GDDRAM or reading the status from status register is controlled by $\overline{D/C}$. $\overline{R/W}$ (\overline{WR}) input serves as data write latch signal (clock) when low provided that $\overline{CS1}$ and $\overline{CS2}$ are low and high respectively. Whether writing the display data to the GDDRAM or writing the command to the command register is controlled by $\overline{D/C}$. A dummy read is also required before the first actual display data read for 8080-series interface. Please refer to figure 13 & 14 on page 42 & 43 for Parallel Interface Timing Diagram of 8080-series microprocessors.

c) MPU 4-wires Serial Interface

The 4-wires serial interface consists of serial clock SCK (D6), serial data SDA (D7), $\overline{D/C}$, $\overline{CS1}$ and $\overline{CS2}$. SDA is shifted into a 8-bit shift register on every rising edge of SCK in the order of data bit 7, data bit 6, ..., data bit 0. $\overline{D/C}$ is sampled on every eighth clock to determine whether the data byte in the shift register is written to the Display Data RAM or command register at the same clock. Please refer to figure 15 & 16 on page 43 & 44 for serial interface timing.

Remarks: For SPI mode, it is necessary to add one time of software reset command (code: E2) in the first line of the initialization code.

	6800-series Parallel Interface	8080-series Parallel Interface	4-wires Serial Peripheral Interface
Data Read	8-bits	8-bits	No
Data Write	8-bits	8-bits	8-bits
Command Read	Status only	Status only	No
Command Write	Yes	Yes	Yes

Table 4 - Data Bus selection Modes

7.2 Reset Circuit

This block is integrated into the Microprocessor Interface Logic that includes Power On Reset circuitry and the hardware reset pin, \overline{RES} . Both of these having the same reset function. Once \overline{RES} receives a negative reset pulse, all internal circuitry will start to initialize. Minimum pulse width for completing the reset sequence is 20us. Status of the chip after reset is given by:

When \overline{RES} input is low, the chip is initialized to the following:

- | | |
|--|--|
| 1) Display ON/OFF: | Display is turned OFF |
| 2) Normal/Inverse Display: | Normal Display |
| 3) Com Scan Direction: | COM0 -> COM67 |
| 4) Internal Oscillator: | Enable |
| 5) Internal DC-DC Converter: | Disable |
| 6) Bias Divider: | Disable |
| 7) Booster level: | Determine by pins [B0, B1] |
| 8) Bias ratio: | 1/8 for 32 & 54 Mux mode
1/9 for 64 & 68 Mux mode |
| 9) Multiplex ratio: | Determine by pins [C0, C1] |
| 10) Electronic volume control: | 20 hex |
| 11) Built-in resistance ratio: | 24 hex |
| 12) Average temperature gradient: | -0.05%/°C |
| 13) Display data column address mapping: | Normal |
| 14) Display start line: | GDDRAM row 0 |
| 15) Column address counter: | 00 hex |
| 16) Page address: | 00 hex |
| 17) Static indicator: | Disable |
| 18) Read-modify-write mode: | Disable |
| 19) Test mode: | Disable |
| 20) Shift register data in serial interface: | Clear |

Note: Please find more explanation in the Applications Note attached at the back of the specification.

7.3 Command Decoder and Command Interface

This module determines whether the input data is interpreted as data or command. Data is directed to this module based upon the input of the D/\overline{C} pin. If D/\overline{C} pin is high, data is written to Graphic Display Data RAM (GDDRAM). If D/\overline{C} pin is low, the input at D0 – D7 is interpreted as a Command and it will be decoded. The decoded command will be written to the corresponding command register.

7.4 Graphic Display Data RAM (GDDRAM)

The GDDRAM is a bit mapped static RAM holding the bit pattern to be displayed. The size of the RAM is 132 x 68 = 8,976bits. Table 5 on page 18 is a description of the GDDRAM address map in which the display start line register is set at 18H. For mechanical flexibility, re-mapping on both Segment and Common outputs are provided. For vertical scrolling of display, an internal register storing the display start line can be set to control the portion of the RAM data mapped to the display. For those GDDRAM out of the display common range, they could still be accessed, for either preparation of vertical scrolling data or even for the system usage. Please be noticed that the display offset cannot be greater than the default mux mode for any circumstance.

RAM Row	RAM Column	Normal Remapped	00h 83h	01h 82h	02h 81h	03h 80h	-----	80h 03h	81h 02h	82h 01h	83h 00h	68 Mux Mode Common Pins		64 Mux Mode Common Pins		54 Mux Mode Common Pins		32 Mux Mode Common Pins	
												Normal	Remapped	Normal	Remapped	Normal	Remapped	Normal	Remapped
00h	Page 0	DB0 (LSB)					-----					44	23	40	23	30	23	8	23
01h		DB1					-----					45	22	41	22	31	22	9	22
02h		DB2					-----					46	21	42	21	32	21	10	21
03h		DB3					-----					47	20	43	20	33	20	11	20
04h		DB4					-----					48	19	44	19	34	19	12	19
05h		DB5					-----					49	18	45	18	35	18	13	18
06h		DB6					-----					50	17	46	17	36	17	14	17
07h		DB7 (MSB)					-----					51	16	47	16	37	16	15	16
08h	Page 1	DB0 (LSB)					-----					52	15	48	15	38	15	16	15
09h		DB1					-----					53	14	49	14	39	14	17	14
0Ah		DB2					-----					54	13	50	13	40	13	18	13
0Bh		DB3					-----					55	12	51	12	41	12	19	12
0Ch		DB4					-----					56	11	52	11	42	11	20	11
0Dh		DB5					-----					57	10	53	10	43	10	21	10
0Eh		DB6					-----					58	9	54	9	44	9	22	9
0Fh		DB7 (MSB)					-----					59	8	55	8	45	8	23	8
10h	Page 2	DB0 (LSB)					-----					60	7	56	7	46	7	24	7
11h		DB1					-----					61	6	57	6	47	6	25	6
12h		DB2					-----					62	5	58	5	48	5	26	5
13h		DB3					-----					63	4	59	4	49	4	27	4
14h		DB4					-----					64	3	60	3	50	3	28	3
15h		DB5					-----					65	2	61	2	51	2	29	2
16h		DB6					-----					66	1	62	1	52	1	30	1
17h		DB7 (MSB)					-----					67	0	63	0	53	0	31	0
18h	Page 3	DB0 (LSB)					-----					0	67	0	63	0	53	0	31
19h		DB1					-----					1	66	1	62	1	52	1	30
1Ah		DB2					-----					2	65	2	61	2	51	2	29
1Bh		DB3					-----					3	64	3	60	3	50	3	28
1Ch		DB4					-----					4	63	4	59	4	49	4	27
1Dh		DB5					-----					5	62	5	58	5	48	5	26
1Eh		DB6					-----					6	61	6	57	6	47	6	25
1Fh		DB7 (MSB)					-----					7	60	7	56	7	46	7	24
20h	Page 4	DB0 (LSB)					-----					8	59	8	55	8	45	Non-select	Non-select
21h		DB1					-----					9	58	9	54	9	44	Non-select	Non-select
22h		DB2					-----					10	57	10	53	10	43	Non-select	Non-select
23h		DB3					-----					11	56	11	52	11	42	Non-select	Non-select
24h		DB4					-----					12	55	12	51	12	41	Non-select	Non-select
25h		DB5					-----					13	54	13	50	13	40	Non-select	Non-select
26h		DB6					-----					14	53	14	49	14	39	Non-select	Non-select
27h		DB7 (MSB)					-----					15	52	15	48	15	38	Non-select	Non-select
28h	Page 5	DB0 (LSB)					-----					16	51	16	47	16	37	Non-select	Non-select
29h		DB1					-----					17	50	17	46	17	36	Non-select	Non-select
2Ah		DB2					-----					18	49	18	45	18	35	Non-select	Non-select
2Bh		DB3					-----					19	48	19	44	19	34	Non-select	Non-select
2Ch		DB4					-----					20	47	20	43	20	33	Non-select	Non-select
2Dh		DB5					-----					21	46	21	42	21	32	Non-select	Non-select
2Eh		DB6					-----					22	45	22	41	22	31	Non-select	Non-select
2Fh		DB7 (MSB)					-----					23	44	23	40	23	30	Non-select	Non-select
30h	Page 6	DB0 (LSB)					-----					24	43	24	39	24	29	Non-select	Non-select
31h		DB1					-----					25	42	25	38	25	28	Non-select	Non-select
32h		DB2					-----					26	41	26	37	26	27	Non-select	Non-select
33h		DB3					-----					27	40	27	36	27	26	Non-select	Non-select
34h		DB4					-----					28	39	28	35	28	25	Non-select	Non-select
35h		DB5					-----					29	38	29	34	29	24	Non-select	Non-select
36h		DB6					-----					30	37	30	33	Non-select	Non-select	Non-select	Non-select
37h		DB7 (MSB)					-----					31	36	31	32	Non-select	Non-select	Non-select	Non-select
38h	Page 7	DB0 (LSB)					-----					32	35	32	31	Non-select	Non-select	Non-select	Non-select
39h		DB1					-----					33	34	33	30	Non-select	Non-select	Non-select	Non-select
3Ah		DB2					-----					34	33	34	29	Non-select	Non-select	Non-select	Non-select
3Bh		DB3					-----					35	32	35	28	Non-select	Non-select	Non-select	Non-select
3Ch		DB4					-----					36	31	36	27	Non-select	Non-select	Non-select	Non-select
3Dh		DB5					-----					37	30	37	26	Non-select	Non-select	Non-select	Non-select
3Eh		DB6					-----					38	29	38	25	Non-select	Non-select	Non-select	Non-select
3Fh		DB7 (MSB)					-----					39	28	39	24	Non-select	Non-select	Non-select	Non-select
40h	Page 8	DB0 (LSB)					-----					40	27	ICON	ICON	ICON	ICON	ICON	ICON
41h		DB1					-----					41	26						
42h		DB2					-----					42	25						
43h		DB3					-----					43	24						

Remarks: DB0 – DB7 represent the data bit of the GDDRAM.
 “Non-select” means no common signal will be selected to support those output ROW pins.

Table 5 - Graphic Display Data RAM (GDDRAM) Address Map with Display Start Line set to 18h

7.5 LCD Driving Voltage Generator and Regulator

This module generates the LCD voltage required for display driving output. It takes a single supply input and generates necessary bias voltage. It consists of:

1) 2X, 3X, 4X and 5X regulated DC-DC voltage converter

The built-in DC-DC regulated voltage converter is used to generate the large positive voltage supply. SSD1805 can produce 2X, 3X, 4X or 5X boosting from the potential different between $V_{SS1} - V_{CI}$. No external boosting capacitors are required for configuration. Please refer to the command table for detail description. The feedback gain control for LCD driving contrast curves can be selected by IRS pin to either internal (IRS pin = H) or external (IRS pin = L). If internal resistor network is enabled, eight settings can be selected through software command. If external control is selected, external resistors are required to connect between V_{SS} and V_F (R1), and between V_F and V_{OUT} (R2). See application circuit diagrams for detail connections.

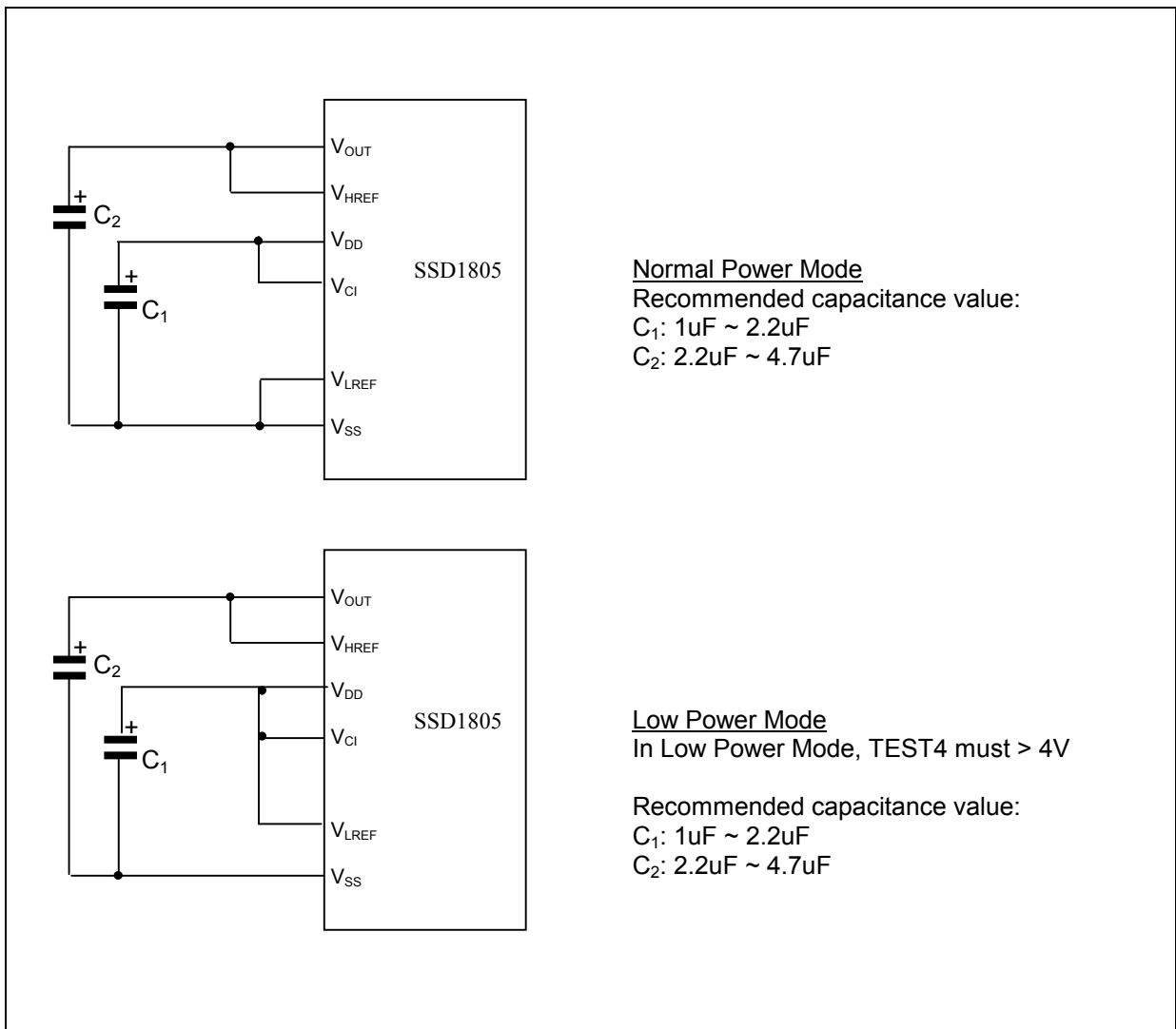

Figure 4 - SSD1805 Hardware configuration

2) Bias Divider

If the output op-amp buffer option in Set Power Control Register command is enabled, this circuit block will divide the regulator output (V_{OUT}) to give the LCD driving levels. The divider does not require external capacitors to reduce the external hardware and pin counts.

3) Bias Ratio Selection circuitry

The software control circuit of 1/4 to 1/9 bias ratio in order to match the characteristic of LCD panel.

- 4) Contrast Control (Voltages referenced to V_{SS})
 Software control of the 64 contrast voltage levels at each voltage regulator feedback gain. The equation of calculating the LCD driving voltage is given as:

Command Set	000	001	010	011	100	101	110	111
Gain = $1+R_2/R_1$	4.96	5.70	6.54	7.41	8.33	8.95	10.05	11.01

Table 6 - Gain Setting

$$V_{out} = \left(1 + \frac{R_2}{R_1}\right) * V_{con}$$

$$V_{con} = \left(1 - \frac{121 - \alpha}{210}\right) * V_{ref}$$

where $V_{ref} = 1.6$ and $\alpha =$ contrast setting

Please refer to figure 5 on page 21 for the contrast curve with 8 sets of internal resistor network gain.

- 5) Self adjust temperature compensation circuitry
 Provide 4 different compensation grade selections to satisfy the various liquid crystal temperature grades. The grading can be selected by software control. Defaulted temperature coefficient (TC) value is $-0.05\%/^{\circ}\text{C}$.

TC Settings	Temperature compensation coefficient [$\%/^{\circ}\text{C}$]	Vref typical value [V]
TC0	-0.05	1.60
TC2	-0.15	1.70
TC4	-0.20	1.75
TC7	-0.25	1.85

Table 7 - Temperature compensation coefficient

SSD1805 Contrast Curve

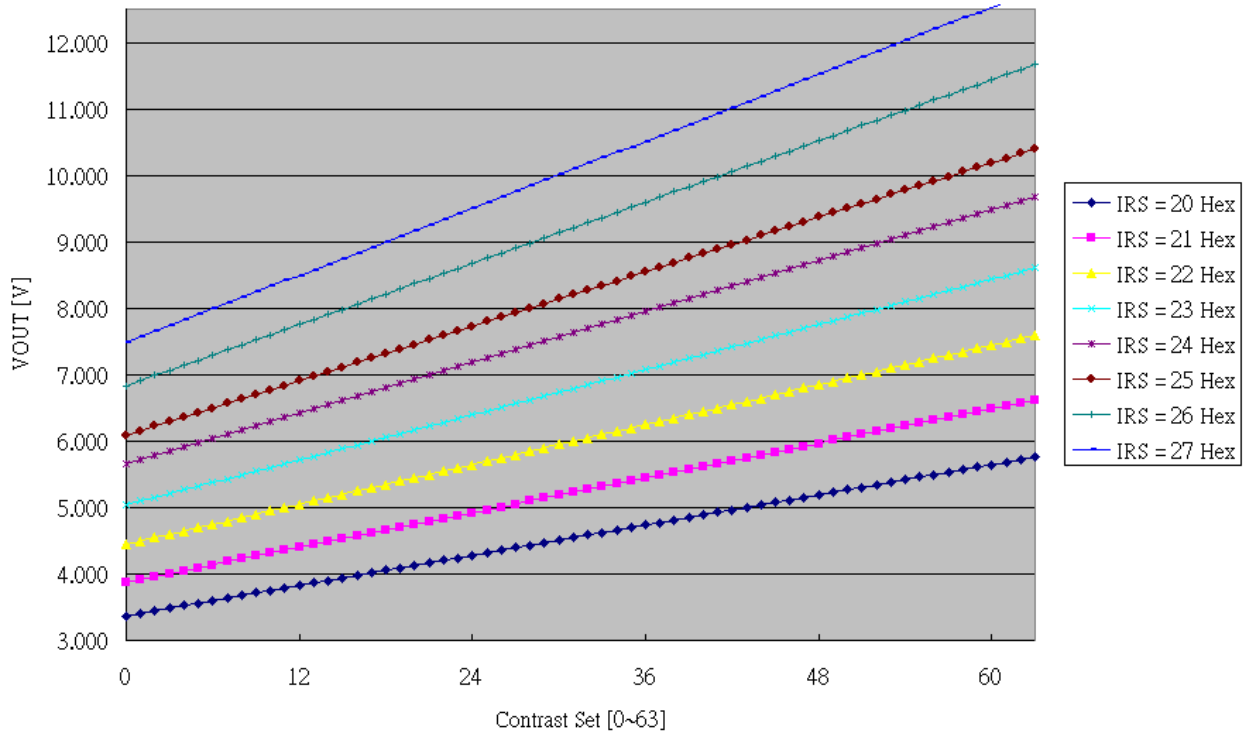

Figure 5 - Contrast curve

7.6 Oscillator Circuit

This module is an On-Chip low power temperature compensation oscillator circuitry. The oscillator generates the clock for the DC-DC voltage converter. This clock is also used in the Display Timing Generator. Please refer to the figure 6 for the typical frame frequency at different temperature.

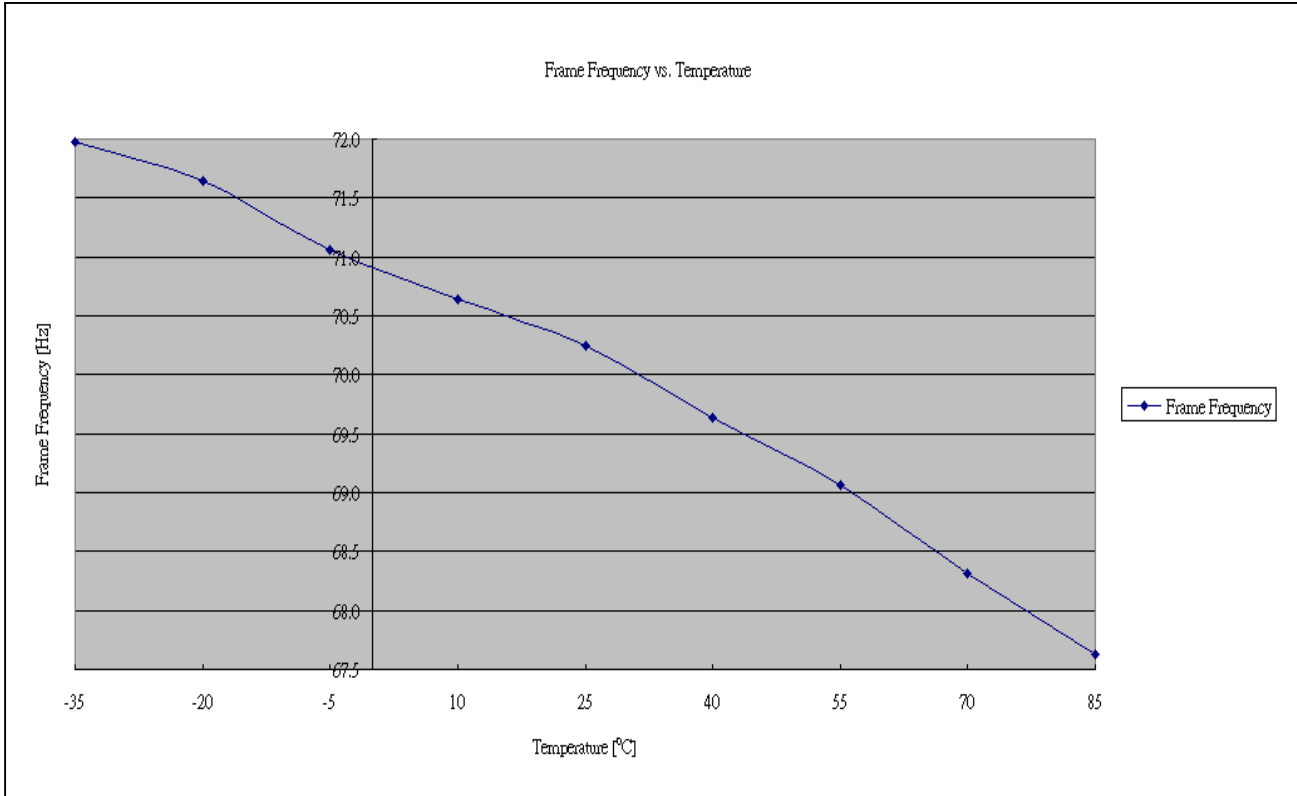

Figure 6 - Oscillator typical frame frequency with variation in temperature

7.7 Display Data Latch

This block is a series of latches carrying the display signal information. These latches hold the data, which will be fed to the HV Buffer Cell and Level Selector to output the required voltage level. The numbers of latches of different members are given by:

32 Mux mode: $132 + 33 = 165$

54 Mux mode: $132 + 55 = 187$

64 Mux mode: $132 + 65 = 197$

68 Mux mode: $132 + 68 = 200$

7.8 HV Buffer Cell (Level Shifter)

This block is embedded in the Segment/Common Driver Circuits. HV Buffer Cell works as a level shifter, which translates the low voltage output signal to the required driving voltage. The output is shifted out with an internal FRM clock, which comes from the Display Timing Generator. The voltage levels are given by the level selector that is synchronized with the internal M signal.

7.9 Level Selector

This block is embedded in the Segment/Common Driver Circuits. Level Selector is a control of the display synchronization. Display voltage levels can be separated into two sets and used with different cycles. Synchronization is important since it selects the required LCD voltage level to the HV Buffer Cell, which in turn outputs the COM or SEG LCD waveform.

7.10 LCD Panel Driving Waveform

Figure 7 is an example of how the Common and Segment drivers may be connected to a LCD panel. The waveforms provided illustrate the desired multiplex scheme.

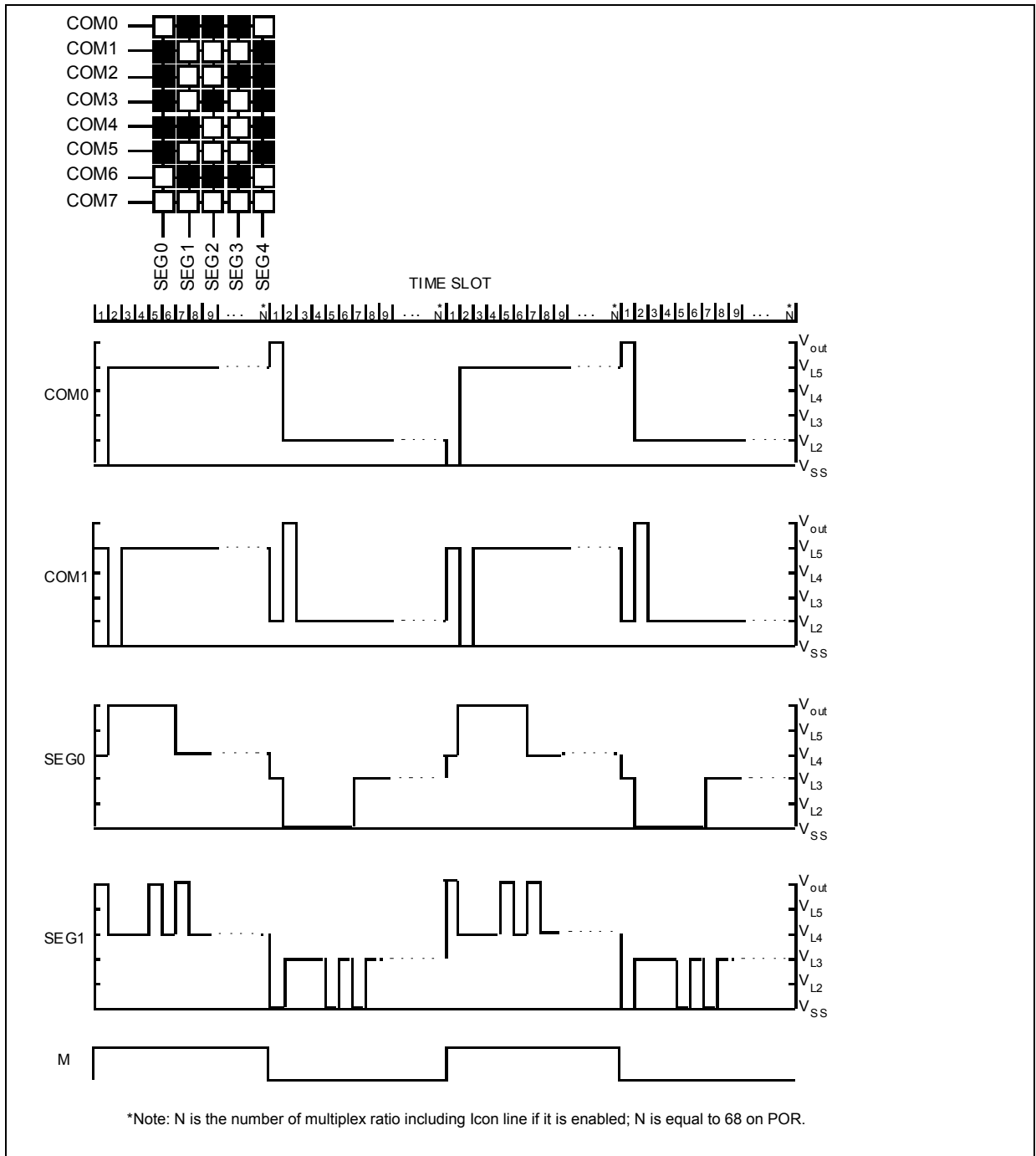

Figure 7 - LCD Driving Waveform

8 COMMAND TABLE

Table 8 - Command Table ($\overline{D}/\overline{C} = 0$, R/\overline{W} (\overline{WR}) = 0, $E=1$ ($\overline{RD} = 1$) unless specific setting is stated)

D/C	Hex	D7	D6	D5	D4	D3	D2	D1	D0	Command	Description
0	00 – 0F	0	0	0	0	X ₃	X ₂	X ₁	X ₀	Set Lower Column Address	Set the lower nibble of the column address register using X ₃ X ₂ X ₁ X ₀ as data bits. The lower nibble of column address is reset to 0000b after POR.
0	10 – 1F	0	0	0	1	X ₃	X ₂	X ₁	X ₀	Set Higher Column Address	Set the higher nibble of the column address register using X ₃ X ₂ X ₁ X ₀ as data bits. The higher nibble of column address is reset to 0000b after POR.
0	20 – 27	0	0	1	0	0	X ₂	X ₁	X ₀	Set Internal Gain Resistor Ratio	Feedback gain of the internal regulated DC-DC converter for generating V _{OUT} increases as X ₂ X ₁ X ₀ increased from 000b to 111b. After POR, X ₂ X ₁ X ₀ = 100b.
0	28 – 2F	0	0	1	0	1	X ₂	1	X ₀	Set Power Control Register	X ₀ =0: turns off the output op-amp buffer (POR) X ₀ =1: turns on the output op-amp buffer X ₂ =0: turns off the internal voltage booster (POR) X ₂ =1: turns on the internal voltage booster
0 0	40 – 7F	0 *	1 Y ₆	X ₅ Y ₅	X ₄ Y ₄	X ₃ Y ₃	X ₂ Y ₂	X ₁ Y ₁	X ₀ Y ₀	Set Display Start Line	For 68 MUX mode, set X ₅ X ₄ X ₃ X ₂ X ₁ X ₀ = 111111 and set the GDDRAM display start line register from 0-67 using Y ₆ Y ₅ Y ₄ Y ₃ Y ₂ Y ₁ Y ₀ For 64/54/32 MUX modes, set GDDRAM display start line register from 0-63 using X ₅ X ₄ X ₃ X ₂ X ₁ X ₀ . There is no need to send the Y ₆ Y ₅ Y ₄ Y ₃ Y ₂ Y ₁ Y ₀ parameters. Display start line register is reset to 000000 after POR for all MUX modes.
0	84 – 87	1	0	0	0	0	1	X ₁	X ₀	Set Boost Level	Set the DC-DC multiplying factor from 2X to 5X. X ₁ X ₀ : 00: 3X 01: 4X 10: 5X 11: 2X Remarks: The POR default boosting level is determined by hardware selection pin, B0 & B1.
0 0	81	1 0	0 0	0 X ₅	0 X ₄	0 X ₃	0 X ₂	0 X ₁	1 X ₀	Set Contrast Control Register	Select contrast level from 64 contrast steps. Contrast increases (V _{OUT} decreases) as X ₅ X ₄ X ₃ X ₂ X ₁ X ₀ is increased from 000000b to 111111b. X ₅ X ₄ X ₃ X ₂ X ₁ X ₀ = 100000b after POR
0	A0 – A1	1	0	1	0	0	0	0	X ₀	Set Segment Re-map	X ₀ =0: column address 00h is mapped to SEG0 (POR) X ₀ =1: column address 83h is mapped to SEG0 Refer to Table 5 on page 16 for example.
0	A2 – A3	1	0	1	0	0	0	1	X ₀	Set LCD Bias	X ₀ =0: POR default bias: 32 MUX mode = 1/8 54 MUX mode = 1/8 64 MUX mode = 1/9 68 MUX mode = 1/9 X ₀ =1: alternate bias: 32 MUX mode = 1/6 54 MUX mode = 1/6 64 MUX mode = 1/7 68 MUX mode = 1/7 For other bias ratio settings, see “Set 1/4 Bias Ratio” and “Set Bias Ratio” in Extended Command Set.
0	A4 – A5	1	0	1	0	0	1	0	X ₀	Set Entire Display On/Off	X ₀ =0: normal display (POR) X ₀ =1: entire display on
0	A6 – A7	1	0	1	0	0	1	1	X ₀	Set Normal/Reverse Display	X ₀ =0: normal display (POR) X ₀ =1: reverse display

D/C	Hex	D7	D6	D5	D4	D3	D2	D1	D0	Command	Description
0	AE – AF	1	0	1	0	1	1	1	X ₀	Set Display On/Off	X ₀ =0: turns off LCD panel (POR) X ₀ =1: turns on LCD panel
0	B0 – B8	1	0	1	1	X ₃	X ₂	X ₁	X ₀	Set Page Address	Set GDDRAM Page Address (0-8) for read/write using X ₃ X ₂ X ₁ X ₀
0	C0 – C8	1	1	0	0	X ₃	*	*	*	Set COM Output Scan Direction	X ₃ =0: normal mode (POR) X ₃ =1: remapped mode, COM0 to COM [N-1] becomes COM [N-1] to COM0 when Multiplex ratio is equal to N. See Table 5 on page 16 for detail mapping.
0	E0	1	1	1	0	0	0	0	0	Set Read-Modify-Write Mode	Read-Modify-Write mode will be entered in which the column address will not be increased during display data read. After POR, Read-modify-write mode is turned OFF.
0	E2	1	1	1	0	0	0	1	0	Software Reset	Initialize internal status registers.
0	EE	1	1	1	0	1	1	1	0	Set End of Read-Modify-Write Mode	Exit Read-Modify-Write mode. RAM Column address before entering the mode will be restored. After POR, Read-modify-write mode is OFF.
0 0	AC – AD	1 *	0 *	1 *	0 *	1 *	1 *	0 Y ₁	X ₀ Y ₀	Indicator Display Mode	X ₀ = 0: indicator off (POR, second command byte is not required) X ₀ = 1: indicator on (second command byte required) Y ₁ Y ₀ = 00: indicator off Y ₁ Y ₀ = 01: indicator on and blinking at ~1 second interval Y ₁ Y ₀ = 10: indicator on and blinking at ~1/2 second interval Y ₁ Y ₀ = 11: indicator on constantly This second byte command is required ONLY when “Set Indicator On” command is sent.
0	E3	1	1	1	0	0	0	1	1	NOP	Command result in No Operation.
0	F0 – FF	1	1	1	1	*	*	*	*	Set Test Mode	Reserved for IC testing. Do NOT use.
0 0 0 0	AE A5	1 1 1 *	0 0 0 *	1 1 1 *	0 0 0 *	1 0 1 *	1 1 1 *	1 0 0 X ₁	0 1 X ₀ X ₀	Set Power Save Mode	Either standby or sleep mode will be entered using compound commands. Issue compound commands “Set Display Off” followed by “Set Entire Display On”. Standby mode will be entered when the static indicator is on constantly. Sleep mode will be entered when static indicator is off.

EXTENDED COMMAND TABLE

Table 9 - Extended Command Table($\overline{D/C} = 0, \overline{R/W} (\overline{WR}) = 0, E=1(\overline{RD} = 1)$ unless specific setting is stated)

D/C	Hex	D7	D6	D5	D4	D3	D2	D1	D0	Command	Description
0 0	82	1 *	0 0	0 0	0 0	0 X ₃	0 X ₂	1 X ₁	0 X ₀	OTP Setting	X ₃ X ₂ X ₁ X ₀ : OTP fuse value 0000 : original contrast 0001 : original contrast + 1 steps 0010 : original contrast + 2 steps 0011 : original contrast + 3 steps 0100 : original contrast + 4 steps 0101 : original contrast + 5 steps 0110 : original contrast + 6 steps 0111 : original contrast + 7 steps 1000 : original contrast - 8 steps 1001 : original contrast - 7 steps 1010 : original contrast - 6 steps 1011 : original contrast - 5 steps 1100 : original contrast - 4 steps 1101 : original contrast - 3 steps 1110 : original contrast - 2 steps 1111 : original contrast - 1 steps
0	83	1	0	0	0	0	0	1	1	OTP Programming	This command starts to program LCD driver with OTP offset value. Each bit can be programmed to 1 once. Detail of OTP programming procedure on page 31
0 0	A8	1 0	0 X ₆	1 X ₅	0 X ₄	1 X ₃	0 X ₂	0 X ₁	0 X ₀	Set Multiplex Ratio	To select multiplex ratio N from 2 to the maximum multiplex ratio (POR value) for each member (including icon line for 65 MUX mode). Max. MUX ratio: 68 MUX: 68 N = X ₆ X ₅ X ₄ X ₃ X ₂ X ₁ X ₀ + 1 + ICON*, (*ICON exist for 64/54/32 MUX mode) e.g. N = 001111b + 2 = 17
0 0	A9	1 X ₇	0 X ₆	1 X ₅	0 X ₄	1 X ₃	0 X ₂	0 X ₁	1 X ₀	Set Bias Ratio Set TC Value Modify Osc. Freq.	MUX X ₁ X ₀ = 00 01 10 11 32 : 1/8 or 1/6(POR) 1/6 or 1/5 1/9 or 1/7 P 54 : 1/8 or 1/6(POR) 1/6 or 1/5 1/9 or 1/7 P 64 : 1/8 or 1/6 1/6 or 1/5 1/9 or 1/7(POR) P 68 : 1/8 or 1/6 1/6 or 1/5 1/9 or 1/7(POR) P P stands for prohibited settings X ₄ X ₃ X ₂ = 000: (TC0) Typ. -0.05 (POR) X ₄ X ₃ X ₂ = 010: (TC2) Typ. -0.15 X ₄ X ₃ X ₂ = 100: (TC4) Typ. -0.20 X ₄ X ₃ X ₂ = 111: (TC7) Typ. -0.25 Increase the value of X ₇ X ₆ X ₅ will increase the oscillator frequency and vice versa. Default Mode: X ₇ X ₆ X ₅ Osc Frequency (Hz) 000 61 001 64 010 68 011 72 (POR) 100 75 101 80 110 90 111 98 Remarks: By software program the multiplex ratio, the typical oscillator frequency is listed above.
0	AA – AB	1	0	1	0	1	0	1	X ₀	Set ¼ Bias Ratio	X ₀ = 0: use normal setting (POR) X ₀ = 1: fixed at 1/4 bias regardless of other bias setting commands

D/C	Hex	D7	D6	D5	D4	D3	D2	D1	D0	Command	Description
0	D0 – D1	1	1	0	1	0	0	0	X ₀	Set icon enabled	X ₀ = 0: icon is off. X ₀ = 1: icon is on. (POR)
0 0	D3	1 0	1 X ₆	0 X ₅	1 X ₄	0 X ₃	0 X ₂	1 X ₁	1 X ₀	Set Display Offset Set Total Frame Phases	After POR, X ₆ X ₅ X ₄ X ₃ X ₂ X ₁ X ₀ = 0 After setting MUX ratio less than default value, data will be displayed at the beginning/towards the end of display matrix. To move display towards Row 0 by L, X ₆ X ₅ X ₄ X ₃ X ₂ X ₁ X ₀ = L To move display away from Row 0 by L, X ₆ X ₅ X ₄ X ₃ X ₂ X ₁ X ₀ = Y-L Note: max. value of L = POR default MUX ratio – display MUX Note: Y represents POR default MUX ratio The On/Off of the Static Icon is given by 3 phases / 1 phase overlapping of the M and MSTAT signals. This command set total phases of the M/MSTAT signals for each frame. The more the total phases, the less the overlapping time and thus the lower the effective driving voltage. X ₅ X ₄ = 00: 5 phases X ₅ X ₄ = 01: 7 phases X ₅ X ₄ = 10: 9 phases (POR) X ₅ X ₄ = 11: 16 phases
0 0	D4	1 0	1 0	0 X ₅	1 X ₄	0 0	1 0	0 0	0 0	Set Display Offset	After POR, X ₆ X ₅ X ₄ X ₃ X ₂ X ₁ X ₀ = 0 After setting MUX ratio less than default value, data will be displayed at the beginning/towards the end of display matrix. To move display towards Row 0 by L, X ₆ X ₅ X ₄ X ₃ X ₂ X ₁ X ₀ = L To move display away from Row 0 by L, X ₆ X ₅ X ₄ X ₃ X ₂ X ₁ X ₀ = Y-L Note: max. value of L = POR default MUX ratio – display MUX Note: Y represents POR default MUX ratio

READ COMMAND TABLE

Table 10 - Read Command Table (D/C = 1, R/W (WR) = 1, E=1(RD = 0) unless specific setting is stated)

D/C	Hex	D7	D6	D5	D4	D3	D2	D1	D0	Command	Description
1	00 - FF	X ₇	X ₆	X ₅	0	X ₃	X ₂	X ₁	X ₀	Status Register Read	X ₇ =0: indicates the driver is ready for command. X ₇ =1: indicates the driver is Busy. X ₆ =0: indicates normal segment mapping with column address. X ₆ =1: indicates reverse segment mapping with column address. X ₅ =0: indicates the display is ON. X ₅ =1: indicates the display is OFF. X ₃ X ₂ X ₁ X ₀ = 0010, the 4-bit is fixed to 0010 which could be used to identify as Solomon Systech Device.

Note: Command patterns other than that given in Command Table and Extended Command Table are prohibited. Otherwise, unexpected result will occur.

9 COMMAND DESCRIPTIONS

9.1 Data Read / Write

To read data from the GDDRAM, input High to $\overline{R/W}$ (\overline{WR}) pin and $\overline{D/C}$ pin for 6800-series parallel mode, input Low to $\overline{E}(\overline{RD})$ pin and High to $\overline{D/C}$ pin for 8080-series parallel mode. No data read is provided in serial interface mode. In normal data read mode, GDDRAM column address pointer will be increased by one automatically after each data read. However, no automatic increase will be performed in read-modify-write mode. Also, a dummy read is required before first valid data is read. See Figure 3 on page 15 in Functional Block Descriptions section for detail waveform diagram. To write data to the GDDRAM, input Low to $\overline{R/W}$ (\overline{WR}) pin and High to $\overline{D/C}$ pin for both 6800-series and 8080-series parallel mode. For serial interface mode, it is always in write mode. GDDRAM column address pointer will be increased by one automatically after each data write. It should be noted that, after the automatic column address increment, the pointer will NOT wrap round to 0. The pointer will exit the memory address space after accessing the last column. Therefore, the pointer should be re-initialized when progress to another page address.

$\overline{D/C}$	$\overline{R/W}$ (\overline{WR})	Action	Auto Address Increment
0	0	Write Command	No
0	1	Read Status	No
1	0	Write Data	Yes
1	1	Read Data	Yes

Table 11 - Automatic Address Increment

9.2 Set Lower Column Address

This command specifies the lower nibble of the 8-bit column address of the display data RAM. The column address will be increased by each data access after it is pre-set by the MCU.

9.3 Set Higher Column Address

This command specifies the higher nibble of the 8-bit column address of the display data RAM. The column address will be increased by each data access after it is pre-set by the MCU.

9.4 Set Internal Gain Resistors Ratio

This command is to enable any one of the eight internal resistor sets for different gains when using internal resistor network (IRS pin pulled high). In other words, this command is used to select which contrast curve from the eight possible selections. Please refer to Functional Block Descriptions section for detail calculation of the LCD driving voltage.

9.5 Set Power Control Register

This command turns on/off the various power circuits associated with the chip. There are two related power sub-circuits could be turned on/off by this command. Internal voltage booster is used to generate the positive voltage supply (V_{OUT}) from the voltage input ($V_{CI} - V_{SS1}$). An external positive power supply is required if this option is turned off. Output op-amp buffer is the internal divider for dividing the different voltage levels from the internal voltage booster, V_{OUT} . External voltage sources should be fed into this driver if this circuit is turned off.

9.6 Set Display Start Line

This command is to set Display Start Line register to determine starting address of display RAM to be displayed by selecting a value from 0 to 67. With value equals to 0, D0 of Page 0 is mapped to COM0. With value equals to 1, D1 of Page0 is mapped to COM0 and so on. Display start line values of 0 to 67 are assigned to Page 0 to 8. Please refer to Table 5 on Page 17 as an example for display start line set to 24 (18h).

9.7 Set Boost level

The internal DC-DC converter factor is set by this command. For SSD1805, 2X to 5X multiplying factors could be selected. The default POR internal DC-DC converter setting can be selected by hardware pin, B0 & B1.

9.8 Set Contrast Control Register

This command adjusts the contrast of the LCD panel by changing the LCD driving voltage, V_{OUT} , provided by the On-Chip power circuits. V_{OUT} is set with 64 steps (6-bit) in the contrast control register by a set of compound commands. See Figure 8 for the contrast control flow.

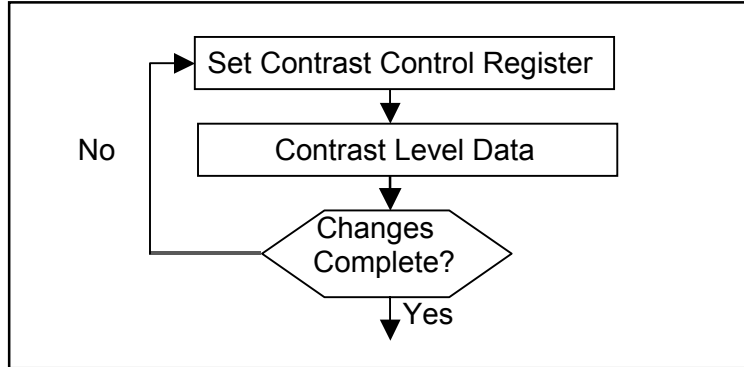

Figure 8 - Contrast Control Flow

9.9 Set Segment Re-map

This command changes the mapping between the display data column addresses and segment drivers. It allows flexibility in mechanical layout of LCD glass design. Please refer to Table 5 on Page 15 for example.

9.10 Set LCD Bias

This command is used to select a suitable bias ratio required for driving the particular LCD panel in use. The selectable values of this command for 68/64 MUX are 1/9 or 1/7, 54/32 MUX are 1/8 or 1/6. For other bias ratio settings, extended commands should be used.

9.11 Set Entire Display On/Off

This command forces the entire display, including the icon row, to be illuminated regardless of the contents of the GDDRAM. In addition, this command has higher priority than the normal/reverse display. This command is used together with "Set Display ON/OFF" command to form a compound command for entering power save mode. See "Set Power Save Mode" later in this section.

9.12 Set Normal/Reverse Display

This command turns the display to be either normal or reverse. In normal display, a RAM data of 1 indicates an illumination on the corresponding pixel. While in reverse display, a RAM data of 0 will turn on the pixel. It should be noted that the icon line will not affect, that is not reverse by this command.

9.13 Set Display On/Off

This command is used to turn the display on or off. When display off is issued with entire display is on, power save mode will be entered. See "Set Power Save Mode" later in this section for details.

9.14 Set Page Address

This command enters the page address from 0 to 8 to the RAM page register for read/write operations. Please refer to Table 5 on Page 17 for detail mapping.

9.15 Set COM Output Scan Direction

This command sets the scan direction of the COM output allowing layout flexibility in LCD module assembly. See Table 5 on Page 17 for the relationship between turning on or off of this feature. In addition, the display will have immediate effect once this command is issued. That is, if this command is sent during normal display, the graphic display will have vertical flipping effect.

9.16 Set Read-Modify-Write Mode

This command puts the chip in read-modify-write mode in which:

1. Column address is saved before entering the mode
2. Column address is increased only after display data write but not after display data read.

This Read-Modify-Write mode is used to save the MCU's loading when a very portion of display area is being updated frequently. As reading the data will not change the column address, it could be get back from the chip and do some operation in the MCU. Then the updated data could be written back to the GDDRAM with automatic address increment. After updating the area, "Set End of Read-Modify-Write Mode" is sent to restore the column address and ready for next update sequence.

9.17 Software Reset

Issuing this command causes some of the chip's internal status registers to be initialized:

Read-Modify-Write mode is off

Static indicator is turned OFF

Display start line register is cleared to 0

Column address counter is cleared to 0

Page address is cleared to 0

Normal scan direction of the COM outputs

Internal gain resistors Ratio is set to 4

Contrast control register is set to 20h

9.18 Set End of Read-Modify-Write Mode

This command relieves the chip from read-modify-write mode. The column address before entering read-modify-write mode will be restored no matter how much modification during the read-modify-write mode.

9.19 Set Indicator On/Off

This command turns on or off the static indicator driven by the M and MSTAT pins.

When the "Set Indicator On" command is sent, the second command byte "Indicator Display Mode" must be followed. However, the "Set Indicator Off" command is a single byte command and no second byte command is required.

The status of static indicator also controls whether standby mode or sleep mode will be entered, after issuing the power save compound command. See "Set Power Save Mode" later in this section.

9.20 NOP

A command causing the chip takes No Operation.

9.21 Set Test Mode

This command forces the driver chip into its test mode for internal testing of the chip. Under normal operation, users should NOT use this command.

9.22 Set Power Save Mode

Entering Standby or Sleep Mode should be done by using a compound command composed of "Set Display ON/OFF" and "Set Entire Display ON/OFF" commands. When "Set Entire Display ON" is issued when display is OFF, either Standby Mode or Sleep Mode will be entered. The status of the Static Indicator will determine which power save mode is entered. If static indicator is off, the Sleep Mode will be entered:

Internal oscillator and LCD power supply circuits are stopped

Segment and Common drivers output V_{SS} level

The display data and operation mode before sleep are held

Internal display RAM can still be accessed

If the static indicator is on, the chip enters Standby Mode that is similar to sleep mode except addition with:

Internal oscillator is on

Static drive system is on

Please also be noted that during Standby Mode, if the software reset command is issued, Sleep Mode will be entered. Both power save modes can be exited by the issue of a new software command or by pulling Low at hardware pin \overline{RES} .

EXTENDED COMMANDS

These commands are used, in addition to basic commands, to trigger the enhanced features designed for the chip.

9.23 OTP setting and programming

OTP (One Time Programming) is a method to adjust V_{OUT} . In order to eliminate the variations of LCD module in term of contrast level, OTP can be used to achieve the best contrast of every LCD modules. OTP setting and programming should include two major steps. Find the OTP offset and OTP programming as following,

Step 1. Find OTP offset

Hardware Reset (sending an active low reset pulse to \overline{RES} pin)

Send original initialization routines

Set and display any test patterns

Adjust the contrast value 0x81, 0x00~0x3F until there is the best visual contrast

OTP setting steps = Contrast value of the best visual contrast - Contrast value of original initialization

Example 1

Contrast value of original initialization = 0x20

Contrast value of the best original initialization = 0x24

OTP offset value = 0x24 - 0x20 = +4

OTP setting command should be (0x82, 0x04)

Example 2:

Contrast value of original initialization = 0x20

Contrast value of the best original initialization = 0x1B

OTP setting = 0x1B - 0x20 = -6

OTP setting command should be (0x82, 0x0A)

Step 2. OTP programming

Hardware Reset (sending an active low reset pulse to \overline{RES} pin)

Connect an external V_{OUT} (see diagram below)

Send OTP setting commands that we find in step 1 (0x82, 0x00~0X0F)

Send OTP programming command (0x83)

Wait at least 2 seconds

Hardware Reset

Verify the result by repeating step 1. (2) – (3)

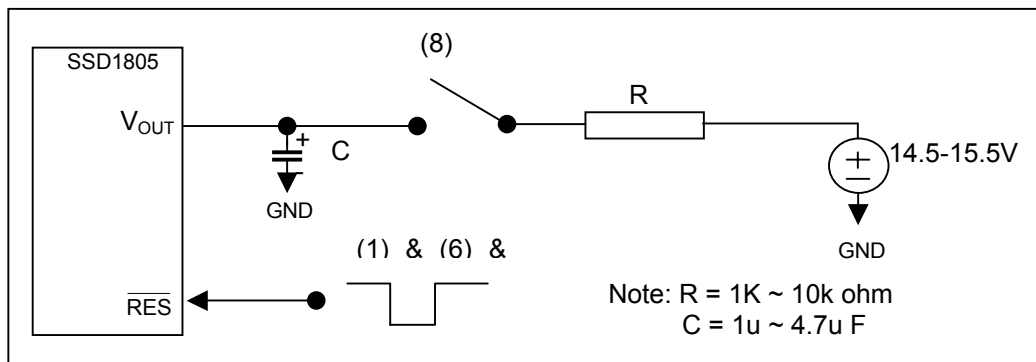

Figure 9 - OTP programming circuitry

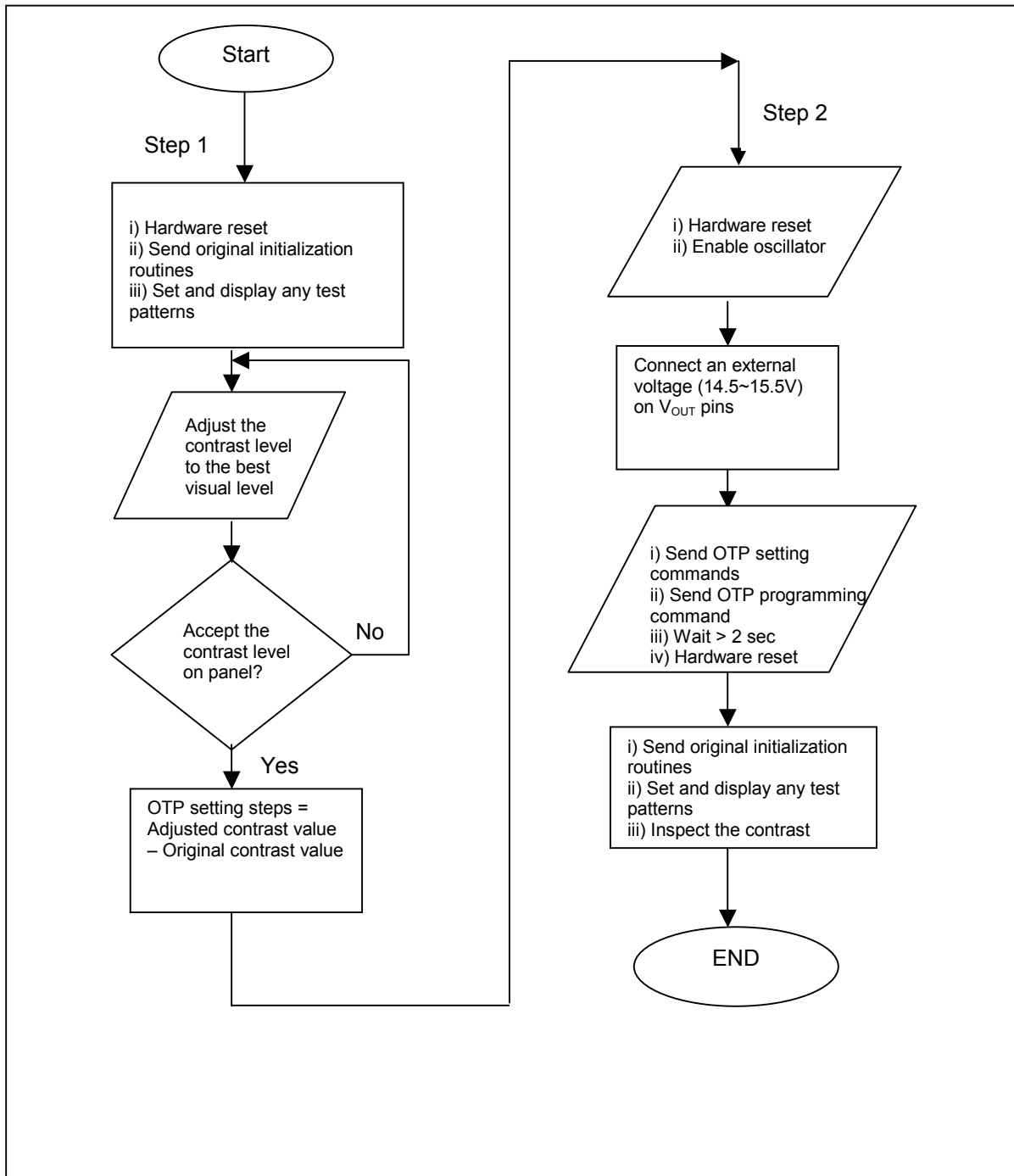

Figure 10 - Flow chart of OTP programming Procedure

OTP Example program

Find the OTP offset:

Hardware reset by sending an active low reset pulse to $\overline{\text{RES}}$ pin
0X2F \ \ turn on the internal voltage booster & output op-amp buffer.
0XA2 \ \ Set Biasing ratio
0XA9 \ \ 1/9 for 68/64 MUX mode
0X62
0X81 \ \ Set target gain and contrast.
0X20 \ \ contrast = 20 Hex.
0X24 \ \ IR4 =>
\ \ Set target display contents
0x00 \ \ set start column address at 0000 binary for lower nibble
0X10 \ \ set start column address at 0000 binary for upper nibble
0XB0 \ \ set page address at page 0
0xAF \ \ display on
OTP offset calculation... target OTP offset value is +6

OTP programming:

Hardware reset by sending an active low reset pulse to $\overline{\text{RES}}$ pin
Connect a external V_{OUT} (14.5V~15.5V)
0X82 \ \ Set OTP offset value to +6 (0110)
0X06 \ \ 0000 $X_3X_2X_1X_0$, where $X_3X_2X_1X_0$ is the OTP offset value
0X83 \ \ Send the OTP programming command.
Wait at least 2 seconds for programming wait time.

Verify the result:

After OTP programming, procedure 2 to 5 are repeated for inspection of the contrast on the panel.

9.24 Set Multiplex Ratio

This command switches default multiplex ratio to any multiplex mode from 2 to the maximum multiplex ratio (POR value), including the icon line.

Max. MUX ratio: 68 for 68 MUX mode
65 for 64 MUX mode including icon line
55 for 54 MUX mode including icon line
33 for 32 MUX mode including icon line

The chip pins ROW0 - ROW67 will be switched to corresponding COM signal output, see Table 12 on Page 35 for examples with and without 8 lines display offset for different MUX. It should be noted that after changing the display multiplex ratio, the bias ratio need to be adjusted to make display contrast consistent.

9.25 Set Bias Ratio

Except the 1/4 bias, all other available bias ratios could be selected using this command plus the "Set LCD Bias" command. For detail setting values and POR default, please refer to the extended command table, Table 9 on Page 26.

9.26 Set Temperature Coefficient (TC) Value

One out of 4 different temperature coefficient settings is selected by this command in order to match various liquid crystal temperature grades. Please refer to the extended command table, Table 9 on Page 26, for detailed TC values.

9.27 Modify Oscillator Frequency

The oscillator frequency can be fine tuned by applying this command. Since the oscillator frequency will be affected by some other factors, this command is not recommended for general usage. Please contact Solomon Systech application engineers for more detail explanation on this command.

9.28 Set 1/4 Bias Ratio

This command sets the bias ratio directly to 1/4. This bias ratio is especially designed for use in under 12 MUX display. In order to restore to other bias ratio, this command must be executed, with LSB=0, before the “Set Multiplex ratio” or “Set LCD Bias” command is sent.

9.29 Set Icon Enabled

This command enables or disables the icon. It should be noticed that the default setting (POR) will enable the icon.

9.30 Set Display Offset

This command should be sent ONLY when the multiplex ratio is set less than the default value. When a lesser multiplex ratio is set, the display will be mapped in the top (y-direction) of the LCD, see the no offset columns on Table 3 on Page 15. Use this command could move the display vertically within the 67 commons. To make the Reduced-MUX Com 0 (Com 0 after reducing the multiplex ratio) towards the Row 0 direction for L lines, the 7-bit data in second command should be given by L. An example for 8 line moving towards to Com 0 direction is given on Table 12 on Page 35. To move in the other direction by L lines, the 8-bit data should be given by 67-L. Please note that the display is confined within the default multiplex value.

9.31 Set Total Frame Phases

The total number of phases for one display frame is set by this command. The Static Icon is generated by the overlapping of M and MSTAT signals. These two pins output either V_{SS} or V_{DD} at same frequency but with phase different. To turn on the Static Icon, 3 phases overlapping is applied to these signals, while 1 phase overlapping is given to the off status. The more the total number of phases in one frame, the less the overlapping time. Thus the lower the effective driving voltage at the Static Icon on the LCD panel.

9.32 Status register Read

This command is issued by pulling D/\bar{C} Low during a data read (refer to Figure 11 on Page 40 and Figure 13 on Page 42 for parallel interface waveforms). It allows the MCU to monitor the internal status of the chip. No status read is provided for serial mode.

Offset by 8 lines - Set 68 Mux mode (C0=1, C1=1)								
Mux ratio	32		54		64		68	
Direction	Normal	Remap	Normal	Remap	Normal	Remap	Normal	Remap
Pin Name								
ROW0	Com8	Com23	Com8	Com45	Com8	Com55	Com8	Com59
ROW1	Com9	Com22	Com9	Com44	Com9	Com54	Com9	Com58
ROW2	Com10	Com21	Com10	Com43	Com10	Com53	Com10	Com57
ROW3	Com11	Com20	Com11	Com42	Com11	Com52	Com11	Com56
ROW4	Com12	Com19	Com12	Com41	Com12	Com51	Com12	Com55
ROW5	Com13	Com18	Com13	Com40	Com13	Com50	Com13	Com54
ROW6	Com14	Com17	Com14	Com39	Com14	Com49	Com14	Com53
ROW7	Com15	Com16	Com15	Com38	Com15	Com48	Com15	Com52
ROW8	Com16	Com15	Com16	Com37	Com16	Com47	Com16	Com51
ROW9	Com17	Com14	Com17	Com36	Com17	Com46	Com17	Com50
ROW10	Com18	Com13	Com18	Com35	Com18	Com45	Com18	Com49
ROW11	Com19	Com12	Com19	Com34	Com19	Com44	Com19	Com48
ROW12	Com20	Com11	Com20	Com33	Com20	Com43	Com20	Com47
ROW13	Com21	Com10	Com21	Com32	Com21	Com42	Com21	Com46
ROW14	Com22	Com9	Com22	Com31	Com22	Com41	Com22	Com45
ROW15	Com23	Com8	Com23	Com30	Com23	Com40	Com23	Com44
ROW16	Com24	Com7	Com24	Com29	Com24	Com39	Com24	Com43
ROW17	Com25	Com6	Com25	Com28	Com25	Com38	Com25	Com42
ROW18	Com26	Com5	Com26	Com27	Com26	Com37	Com26	Com41
ROW19	Com27	Com4	Com27	Com26	Com27	Com36	Com27	Com40
ROW20	Com28	Com3	Com28	Com25	Com28	Com35	Com28	Com39
ROW21	Com29	Com2	Com29	Com24	Com29	Com34	Com29	Com38
ROW22	Com30	Com1	Com30	Com23	Com30	Com33	Com30	Com37
ROW23	Com31	Com0	Com31	Com22	Com31	Com32	Com31	Com36
ROW24	non-select	non-select	Com32	Com21	Com32	Com31	Com32	Com35
ROW25	non-select	non-select	Com33	Com20	Com33	Com30	Com33	Com34
ROW26	non-select	non-select	Com34	Com19	Com34	Com29	Com34	Com33
ROW27	non-select	non-select	Com35	Com18	Com35	Com28	Com35	Com32
ROW28	non-select	non-select	Com36	Com17	Com36	Com27	Com36	Com31
ROW29	non-select	non-select	Com37	Com16	Com37	Com26	Com37	Com30
ROW30	non-select	non-select	Com38	Com15	Com38	Com25	Com38	Com29
ROW31	non-select	non-select	Com39	Com14	Com39	Com24	Com39	Com28
ROW32	non-select	non-select	Com40	Com13	Com40	Com23	Com40	Com27
ROW33	non-select	non-select	Com41	Com12	Com41	Com22	Com41	Com26
ROW34	non-select	non-select	Com42	Com11	Com42	Com21	Com42	Com25
ROW35	non-select	non-select	Com43	Com10	Com43	Com20	Com43	Com24
ROW36	non-select	non-select	Com44	Com9	Com44	Com19	Com44	Com23
ROW37	non-select	non-select	Com45	Com8	Com45	Com18	Com45	Com22
ROW38	non-select	non-select	Com46	Com7	Com46	Com17	Com46	Com21
ROW39	non-select	non-select	Com47	Com6	Com47	Com16	Com47	Com20
ROW40	non-select	non-select	Com48	Com5	Com48	Com15	Com48	Com19
ROW41	non-select	non-select	Com49	Com4	Com49	Com14	Com49	Com18
ROW42	non-select	non-select	Com50	Com3	Com50	Com13	Com50	Com17
ROW43	non-select	non-select	Com51	Com2	Com51	Com12	Com51	Com16
ROW44	non-select	non-select	Com52	Com1	Com52	Com11	Com52	Com15
ROW45	non-select	non-select	Com53	Com0	Com53	Com10	Com53	Com14
ROW46	non-select	non-select	non-select	non-select	Com54	Com9	Com54	Com13
ROW47	non-select	non-select	non-select	non-select	Com55	Com8	Com55	Com12
ROW48	non-select	non-select	non-select	non-select	Com56	Com7	Com56	Com11
ROW49	non-select	non-select	non-select	non-select	Com57	Com6	Com57	Com10
ROW50	non-select	non-select	non-select	non-select	Com58	Com5	Com58	Com9
ROW51	non-select	non-select	non-select	non-select	Com59	Com4	Com59	Com8
ROW52	non-select	non-select	non-select	non-select	Com60	Com3	Com60	Com7
ROW53	non-select	non-select	non-select	non-select	Com61	Com2	Com61	Com6
ROW54	non-select	non-select	non-select	non-select	Com62	Com1	Com62	Com5
ROW55	non-select	non-select	non-select	non-select	Com63	Com0	Com63	Com4
ROW56	non-select	non-select	non-select	non-select	non-select	non-select	Com64	Com3
ROW57	non-select	non-select	non-select	non-select	non-select	non-select	Com65	Com2
ROW58	non-select	non-select	non-select	non-select	non-select	non-select	Com66	Com1
ROW59	non-select	non-select	non-select	non-select	non-select	non-select	Com67	Com0
ROW60	Com0	Com31	Com0	Com53	Com0	Com63	Com0	Com67
ROW61	Com1	Com30	Com1	Com52	Com1	Com62	Com1	Com66
ROW62	Com2	Com29	Com2	Com51	Com2	Com61	Com2	Com65
ROW63	Com3	Com28	Com3	Com50	Com3	Com60	Com3	Com64
ROW64	Com4	Com27	Com4	Com49	Com4	Com59	Com4	Com63
ROW65	Com5	Com26	Com5	Com48	Com5	Com58	Com5	Com62
ROW66	Com6	Com25	Com6	Com47	Com6	Com57	Com6	Com61
ROW67	Com7	Com24	Com7	Com46	Com7	Com56	Com7	Com60

Table 12 - ROW pin assignment for COM signals for SSD1805 in a 68 MUX display (including icon line without/with 8 lines display offset towards ROW0)

Remarks: "Non-select" means no common signal will be selected to support those output ROW pins.

10 MAXIMUM RATINGS

Table 13 - Maximum Ratings (Voltage Referenced to V_{SS})

Symbol	Parameter	Value	Unit
V_{DD}	Supply Voltage	-0.3 to +4.0	V
V_{DDIO}		-0.3 to + 4.0	V
V_{OUT}		0 to +15.0	V
V_{CI}	Input Voltage	$V_{SS}-0.3$ to 4.0	V
I	Current Drain Per Pin Excluding V_{DD} and V_{SS}	25	mA
T_A	Operating Temperature	-30 to +85	°C
T_{stg}	Storage Temperature	-65 to +150	°C
Ron	Input Resistance	1000	ohm

Maximum ratings are those values beyond which damages to the device may occur. Functional operation should be restricted to the limits in the Electrical Characteristics tables or Pin Description section.

This device contains circuitry to protect the inputs against damage due to high static voltages or electric fields; however, it is advised that normal precautions to be taken to avoid application of any voltage higher than maximum rated voltages to this high impedance circuit. For proper operation it is recommended that V_{CI} and V_{OUT} be constrained to the range $V_{SS} < \text{or} = (V_{CI} \text{ or } V_{OUT}) < \text{or} = V_{DD}$. Reliability of operation is enhanced if unused input is connected to an appropriate logic voltage level (e.g., either V_{SS} or V_{DD}). Unused outputs must be left open. This device may be light sensitive. Caution should be taken to avoid exposure of this device to any light source during normal operation. This device is not radiation protected.

11 DC CHARACTERISTICS

Table 14 - DC Characteristics

Symbol	Parameter	Test Condition	Min	Typ	Max	Unit
V _{DD}	System power supply pins of the logic block Range	Recommend Operating Voltage Possible Operating Voltage	1.8	2.7	3.6	V
V _{DDIO}	System power supply pins of the logic block Range	Recommend Operating Voltage Possible Operating Voltage	1.2	-	V _{DD}	V
V _{CI}	Booster Reference Supply Voltage Range	Recommend Operating Voltage Possible Operating Voltage	V _{DD}	-	3.6	V
I _{AC}	Access Mode Supply Current Drain (V _{DD} Pins)	V _{DD} = 2.7V, Voltage Generator On, 4X DC-DC Converter Enabled, Write accessing, T _{cy} = 3.3MHz, Typ. Osc. Freq., Display On, no panel attached.	-	450	750	μA
I _{DP1}	Display Mode Supply Current Drain (V _{DD} Pins)	V _{DD} = 2.7V, V _{OUT} = 9V, regulated DC-DC Converter Disabled, R/W (WR) Halt, Typ. Osc. Freq., Display On, no panel attached.	-	70	150	μA
I _{DP2}	Display Mode Supply Current Drain (V _{DD} Pins)	V _{DD} = 2.7V, V _{OUT} = 9V, Voltage Generator On, 4X DC-DC Converter Enabled, R/W (WR) Halt, Typ. Osc. Freq., Display On, no panel attached.	-	400	700	μA
I _{SB} I _{SLEEP}	Standby Mode Supply Current Drain (V _{DD} Pins) Sleep Mode Supply Current Drain (V _{DD} Pins)	V _{DD} = 2.7V, LCD Driving Waveform Off, Typ. Osc. Freq., R/W (WR) halt. V _{DD} = 2.7V, LCD Driving Waveform Off, Oscillator Off, R/W (WR) halt.	-	45 5	70 10	μA
V _{OUT}	LCD Driving Voltage Generator Output (V _{OUT} Pin)	Display On, Voltage Generator Enabled, DC-DC Converter Enabled, Typ. Osc. Freq., Regulator Enabled, Divider Enabled.	1.8	-	12.5	V
	V _{OUT} Converter Efficiency	5X boosting, no panel loading	93	99	-	%
V _{LCD}	LCD Driving Voltage Input (V _{OUT} Pin)	Voltage Generator Disabled.	1.8	-	12.0	V
V _{OH1}	Logic High Output Voltage	I _{VOUT} = -100uA	0.9* V _{DDIO}	-	V _{DDIO}	V
V _{OL1}	Logic Low Output Voltage	I _{VOUT} = 100uA	0	-	0.1* V _{DDIO}	V
V _{IH1}	Logic High Input voltage		0.8* V _{DDIO}	-	V _{DDIO}	V
V _{IL1}	Logic Low Input voltage		0	-	0.2* V _{DDIO}	V
I _{OH}	Logic High Output Current Source	V _{OUT} = V _{DD} -0.4V V _{OUT} = 0.4V	50	-	-	μA
I _{OL}	Logic Low Output Current Drain		-	-	-50	μA
I _{OZ}	Logic Output Tri-state Current Drain Source		-1	-	1	μA
I _{IL} /I _{IH}	Logic Input Current		-1	-	1	μA
C _{IN}	Logic Pins Input Capacitance		-	5	7.5	pF
ΔV _{OUT}	Variation of V _{OUT} Output (V _{DD} is fixed)	Regulated DC-DC Converter Enabled, Internal Contrast Control Enabled, Set Contrast Control Register = 0	-2	0	2	%

Symbol	Parameter	Test Condition	Min	Typ	Max	Unit
TC0	Temperature Coefficient Compensation Flat Temperature Coefficient (POR)	Regulated DC-DC Converter Enabled	0	-0.05	-0.10	%/°C
TC2	Temperature Coefficient 2*		-0.11	-0.15	-0.17	%/°C
TC4	Temperature Coefficient 4*		-0.18	-0.20	-0.22	%/°C
TC7	Temperature Coefficient 7*		-0.23	-0.25	-0.27	%/°C

The formula for the temperature coefficient is:

$$TC(\%) = \frac{V_{ref} \text{ at } 50^{\circ}\text{C} - V_{ref} \text{ at } 0^{\circ}\text{C}}{50^{\circ}\text{C} - 0^{\circ}\text{C}} \times \frac{1}{V_{ref} \text{ at } 25^{\circ}\text{C}} \times 100\%$$

12 AC CHARACTERISTICS

Table 15 - AC Characteristics (Unless otherwise specified, Voltage Referenced to V_{SS} , $V_{DD} = 2.7V$, $T_A = -30$ to $85^\circ C$)

Symbol	Parameter	Test Condition	Min	Typ	Max	Unit
Fosc	Oscillation Frequency of Display Timing Generator	Internal Oscillator Enabled (default), $V_{DD} = 2.7V$ Remark: Oscillation Frequency vs. Temperature change ($-20^\circ C$ to $70^\circ C$): $-0.05\%/^\circ C$ *	4.4	4.9	5.4	kHz
F _{FRM}	Frame Frequency	132 x 68 Graphic Display Mode, Display ON, Internal Oscillator Enabled		72		Hz
		132 x 68 Graphic Display Mode, Display ON, Internal Oscillator Disabled, External clock with freq., Fext, feeding to CL pin.		653k		Hz

Remarks: Fext stands for the frequency value of external clock feeding to the CL pin.
Fosc stands for the frequency value of internal oscillator.
Frequency limits are based on the software command set: set multiplex ratio to 68 MUX

Table 16 - Parallel 6800-series Interface Timing Characteristics

($T_A = -35$ to 85°C , $V_{DD} = V_{CI} = 1.8\text{V}$ to 3.6V , $V_{DDIO} = 1.2\text{V}$ to V_{DD})

Symbol	Parameter	Min	Typ	Max	Unit
t_{cycle}	Clock Cycle Time	200	1000	-	ns
t_{AS}	Address Setup Time	0	-	25	ns
t_{AH}	Address Hold Time	0	-	-	ns
t_{DSW}	Write Data Setup Time	40	-	-	ns
t_{DHW}	Write Data Hold Time	10	-	-	ns
t_{DHR}	Read Data Hold Time	10	-	50	ns
t_{OH}	Output Disable Time	-	-	40	ns
t_{ACC}	Access Time (RAM)	15	-	-	ns
	Access Time (Command)	15	-	-	ns
PW_{CSL}	Chip Select Low Pulse Width (read RAM)	500	-	-	ns
	Chip Select Low Pulse Width (read Command)	500	-	-	ns
	Chip Select Low Pulse Width (write)	100	-	-	ns
PW_{CSH}	Chip Select High Pulse Width (read)	200	-	-	ns
	Chip Select High Pulse Width (write)	100	-	-	ns
t_{R}	Rise Time	-	-	10	ns
t_{F}	Fall Time	-	-	10	ns

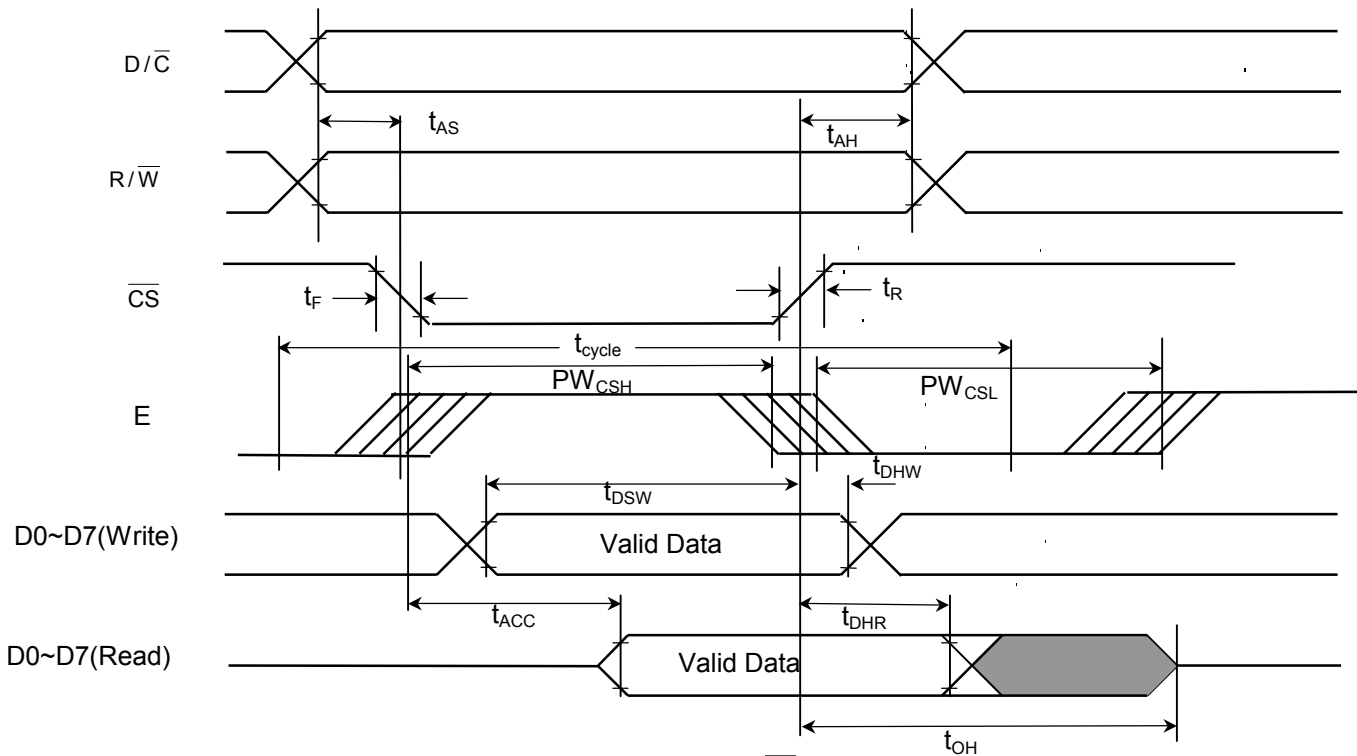

The PW_{CSH} timing reference is 50% of the rising / falling edge of E or $\overline{\text{CS}}$ pin.

The t_{DSW} and t_{DHW} timing is reference to the 50% of rising / falling edge of E or $\overline{\text{CS}}$ pin.

Figure 11 - Parallel 6800-series Interface Timing Characteristics (P/S = H, C68/80 = H)

Table 17 - Parallel 6800-series Interface Timing Characteristics

($T_A = -35$ to 85°C , $V_{DD} = V_{CI} = V_{DDIO} = 1.8\text{V}$ to 3.6V)

Symbol	Parameter	Min	Typ	Max	Unit
t_{cycle}	Clock Cycle Time	100	500	-	ns
t_{AS}	Address Setup Time	0	-	25	ns
t_{AH}	Address Hold Time	0	-	-	ns
t_{DSW}	Write Data Setup Time	30	-	-	ns
t_{DHW}	Write Data Hold Time	5	-	-	ns
t_{DHR}	Read Data Hold Time	10	-	50	ns
t_{OH}	Output Disable Time	-	-	40	ns
t_{ACC}	Access Time (RAM)	15	-	-	ns
	Access Time (Command)	15	-	-	ns
PW_{CSL}	Chip Select Low Pulse Width (read RAM)	250	-	-	ns
	Chip Select Low Pulse Width (read Command)	250	-	-	ns
	Chip Select Low Pulse Width (write)	50	-	-	ns
PW_{CSH}	Chip Select High Pulse Width (read)	100	-	-	ns
	Chip Select High Pulse Width (write)	50	-	-	ns
t_{R}	Rise Time	-	-	10	ns
t_{F}	Fall Time	-	-	10	ns

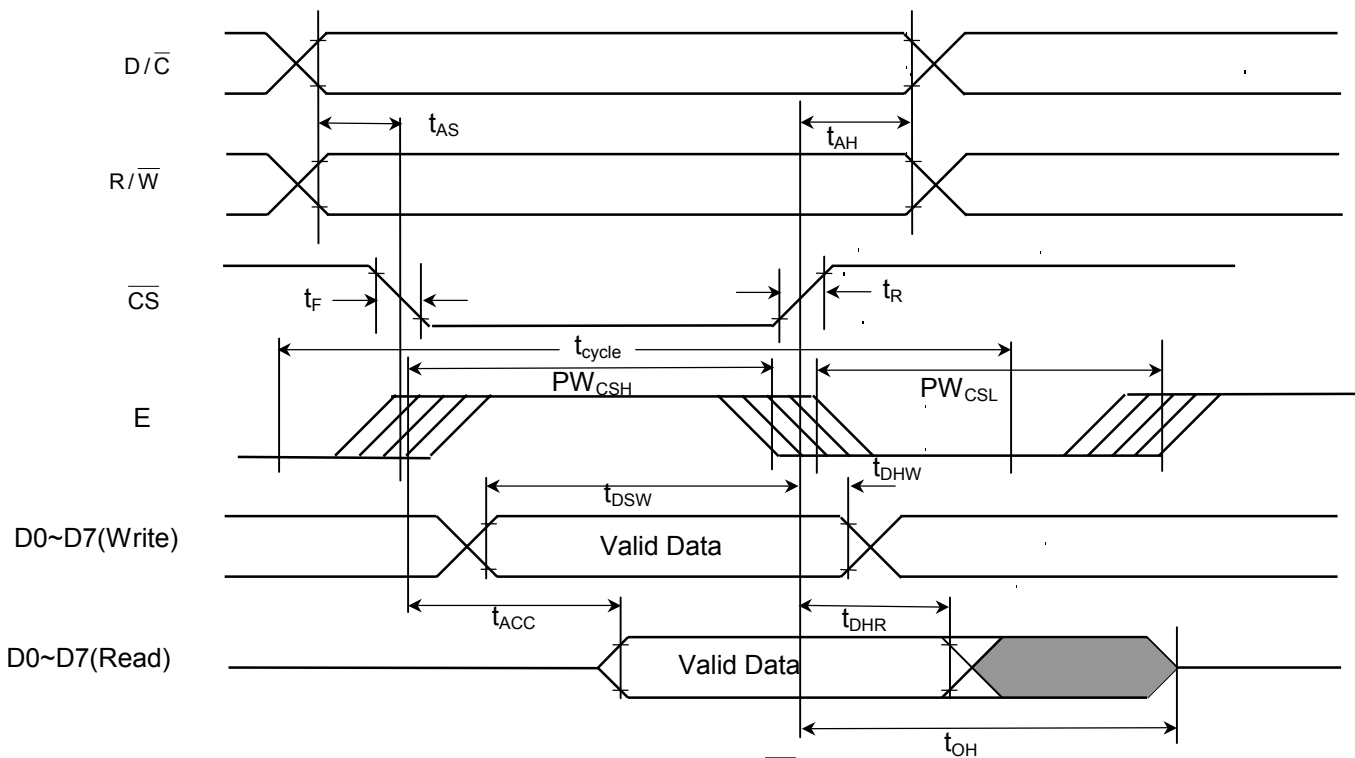

The PW_{CSH} timing reference is 50% of the rising / falling edge of E or $\overline{\text{CS}}$ pin.

The t_{DSW} and t_{DHW} timing is reference to the 50% of rising / falling edge of E or $\overline{\text{CS}}$ pin.

Figure 12 - Parallel 6800-series Interface Timing Characteristics (P/S = H, C68/80 = H)

Table 18 - Parallel 8080-series Interface Timing Characteristics

($T_A = -35$ to 85°C , $V_{DD} = V_{CI} = 1.8\text{V}$ to 3.6V , $V_{DDIO} = 1.2\text{V}$ to V_{DD})

Symbol	Parameter	Min	Typ	Max	Unit
t_{cycle}	Clock Cycle Time	200	1000	-	ns
t_{AS}	Address Setup Time	0	-	25	ns
t_{AH}	Address Hold Time	0	-	-	ns
t_{DSW}	Write Data Setup Time	40	-	-	ns
t_{DHW}	Write Data Hold Time	10	-	-	ns
t_{DHR}	Read Data Hold Time	10	-	50	ns
t_{OH}	Output Disable Time	-	-	40	ns
t_{ACC}	Access Time (RAM)	15	-	-	ns
	Access Time (Command)	15	-	-	ns
PW_{CSL}	Chip Select Low Pulse Width (read RAM)	500	-	-	ns
	Chip Select Low Pulse Width (read Command)	500	-	-	ns
	Chip Select Low Pulse Width (write)	100	-	-	ns
PW_{CSH}	Chip Select High Pulse Width (read)	200	-	-	ns
	Chip Select High Pulse Width (write)	100	-	-	ns
t_{R}	Rise Time	-	-	10	ns
t_{F}	Fall Time	-	-	10	ns

Write Cycle

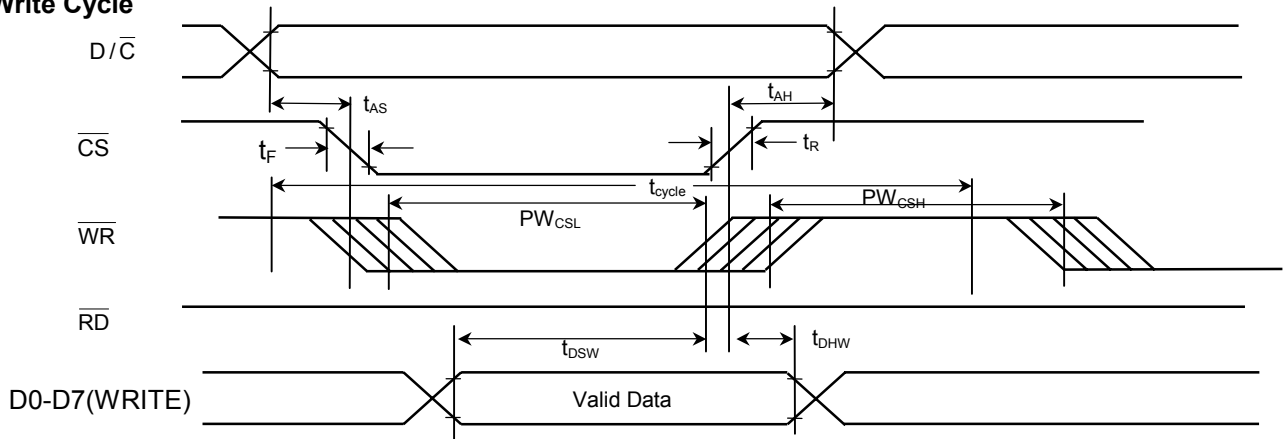

The PW_{CSL} timing reference is 50% of the rising / falling edge of $\overline{\text{WR}}$ or $\overline{\text{CS}}$ pin.

The t_{DSW} and t_{DHW} timing is reference to the 50% of rising / falling edge of $\overline{\text{WR}}$ or $\overline{\text{CS}}$ pin.

Read Cycle

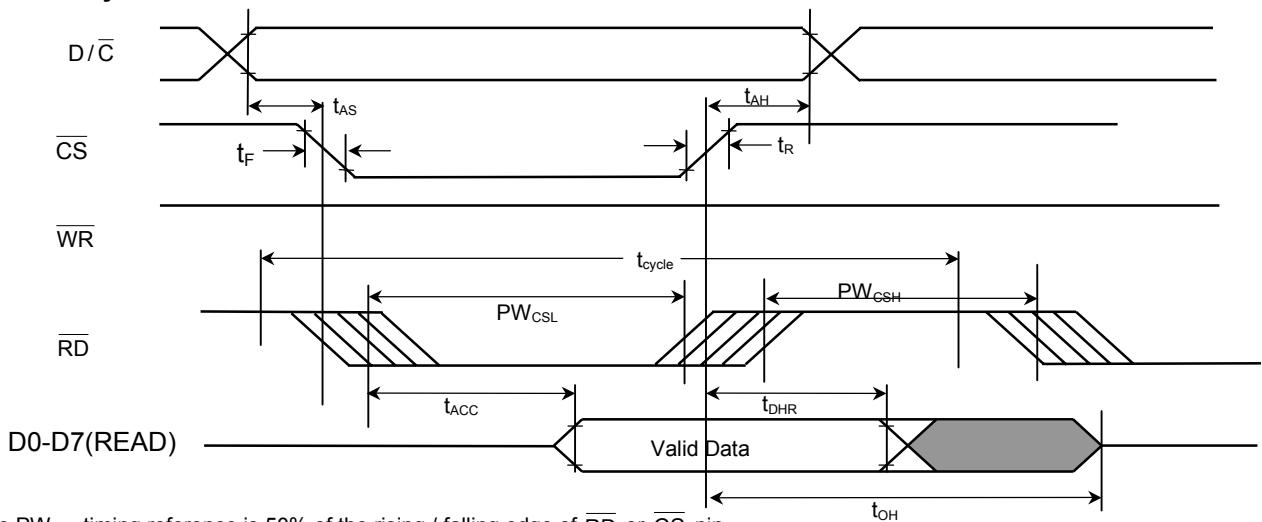

The PW_{CSL} timing reference is 50% of the rising / falling edge of $\overline{\text{RD}}$ or $\overline{\text{CS}}$ pin.

The t_{DSW} and t_{DHW} timing is reference to the 50% of rising / falling edge of $\overline{\text{RD}}$ or $\overline{\text{CS}}$ pin.

Figure 13 - Parallel 8080-series Interface Timing Characteristics (P/S = H, C68/80 = L)

Table 19 - Parallel 8080-series Interface Timing Characteristics

($T_A = -35$ to 85°C , $V_{DD} = V_{CI} = V_{DDIO} = 1.8\text{V}$ to 3.6V)

Symbol	Parameter	Min	Typ	Max	Unit
t_{cycle}	Clock Cycle Time	100	500	-	ns
t_{AS}	Address Setup Time	0	-	25	ns
t_{AH}	Address Hold Time	0	-	-	ns
t_{DSW}	Write Data Setup Time	30	-	-	ns
t_{DHW}	Write Data Hold Time	5	-	-	ns
t_{DHR}	Read Data Hold Time	10	-	50	ns
t_{OH}	Output Disable Time	-	-	40	ns
t_{ACC}	Access Time (RAM)	15	-	-	ns
	Access Time (Command)	15	-	-	ns
PW_{CSL}	Chip Select Low Pulse Width (read RAM)	250	-	-	ns
	Chip Select Low Pulse Width (read Command)	250	-	-	ns
	Chip Select Low Pulse Width (write)	50	-	-	ns
PW_{CSH}	Chip Select High Pulse Width (read)	100	-	-	ns
	Chip Select High Pulse Width (write)	50	-	-	ns
t_{R}	Rise Time	-	-	10	ns
t_{F}	Fall Time	-	-	10	ns

Write Cycle

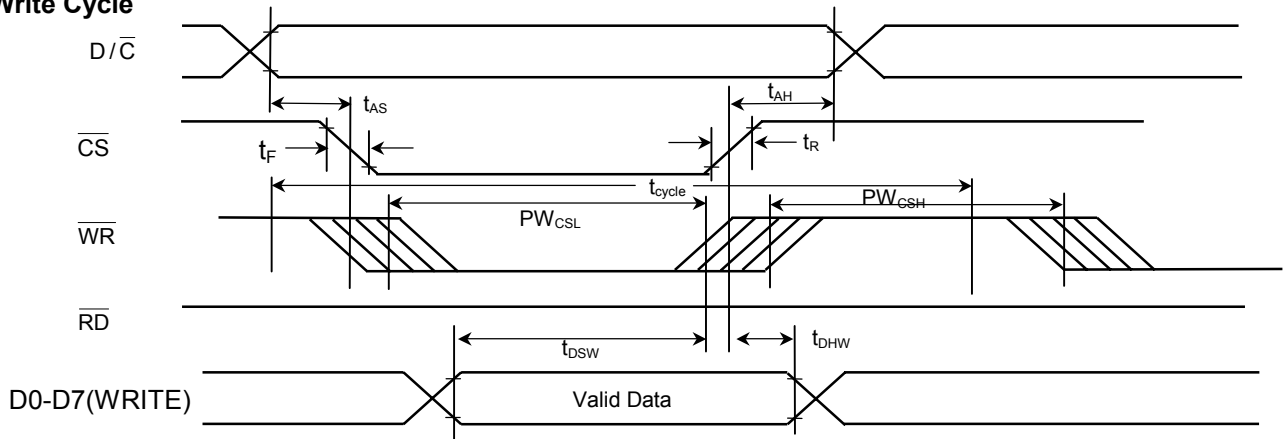

The PW_{CSL} timing reference is 50% of the rising / falling edge of $\overline{\text{WR}}$ or $\overline{\text{CS}}$ pin.

The t_{DSW} and t_{DHW} timing is reference to the 50% of rising / falling edge of $\overline{\text{WR}}$ or $\overline{\text{CS}}$ pin.

Read Cycle

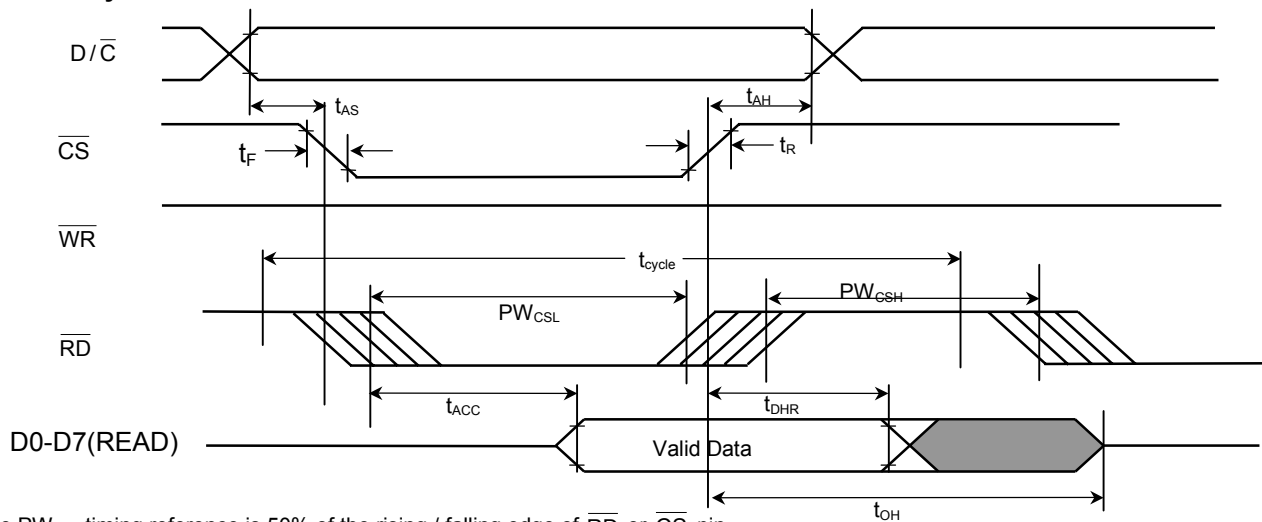

The PW_{CSL} timing reference is 50% of the rising / falling edge of $\overline{\text{RD}}$ or $\overline{\text{CS}}$ pin.

The t_{DSW} and t_{DHW} timing is reference to the 50% of rising / falling edge of $\overline{\text{RD}}$ or $\overline{\text{CS}}$ pin.

Figure 14 - Parallel 8080-series Interface Timing Characteristics (P/S = H, C68/80 = L)

Table 20 - 4-wires Serial Interface Timing Characteristics
 (T_A = -35 to 85°C, V_{DD} = V_{CI} = 1.8V to 3.6V, V_{DDIO} = 1.2V to V_{DD})

Symbol	Parameter	Min	Typ	Max	Unit
t _{cycle}	Clock Cycle Time	111	-	-	ns
t _{AS}	Address Setup Time	15	-	-	ns
t _{AH}	Address Hold Time	10	-	-	ns
t _{DSW}	Write Data Setup Time	60	-	-	ns
t _{DHW}	Write Data Hold Time	60	-	-	ns
T _{CLKL}	Clock Low Time	55.5	-	-	ns
T _{CLKH}	Clock High Time	55.5	-	-	ns
t _{CSS}	Chip Select Setup Time (for D7 input)	60	-	-	ns
t _{CSH}	Chip Select Hold Time (for D0 input)	55.5	-	-	ns
t _R	Rise Time	-	-	10	ns
t _F	Fall Time	-	-	10	ns

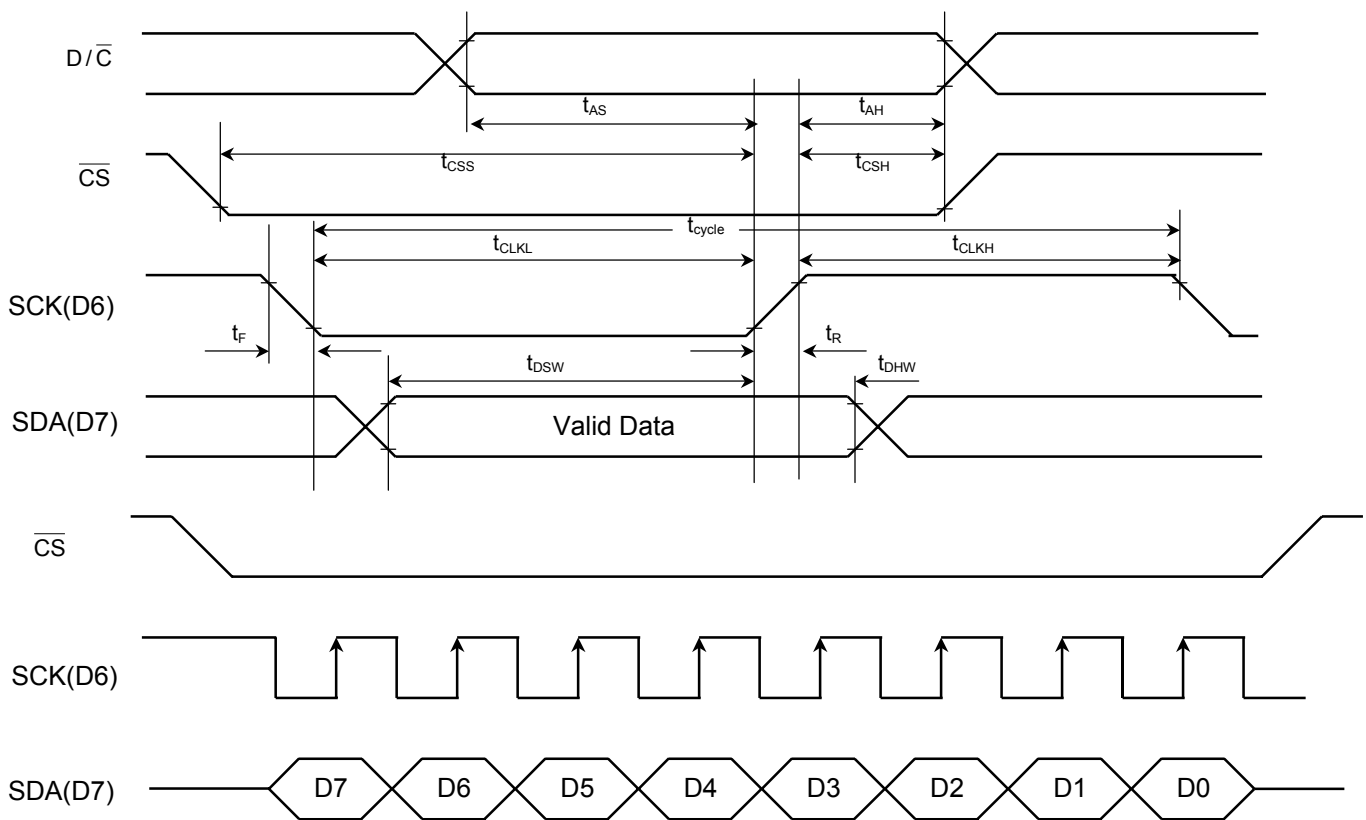

Figure 15 - 4-wires Serial Interface Timing Characteristics (P/S = L, C68/80 = L)

Table 21 - 4-wires Serial Interface Timing Characteristics

($T_A = -35$ to 85°C , $V_{DD} = V_{CI} = V_{DDIO} = 1.8\text{V}$ to 3.6V)

Symbol	Parameter	Min	Typ	Max	Unit
t_{cycle}	Clock Cycle Time	58.8	-	-	ns
t_{AS}	Address Setup Time	10	-	-	ns
t_{AH}	Address Hold Time	5	-	-	ns
t_{DSW}	Write Data Setup Time	30	-	-	ns
t_{DHW}	Write Data Hold Time	30	-	-	ns
T_{CLKL}	Clock Low Time	29.4	-	-	ns
T_{CLKH}	Clock High Time	29.4	-	-	ns
t_{CSS}	Chip Select Setup Time (for D7 input)	30	-	-	ns
t_{CSH}	Chip Select Hold Time (for D0 input)	29.4	-	-	ns
t_{R}	Rise Time	-	-	10	ns
t_{F}	Fall Time	-	-	10	ns

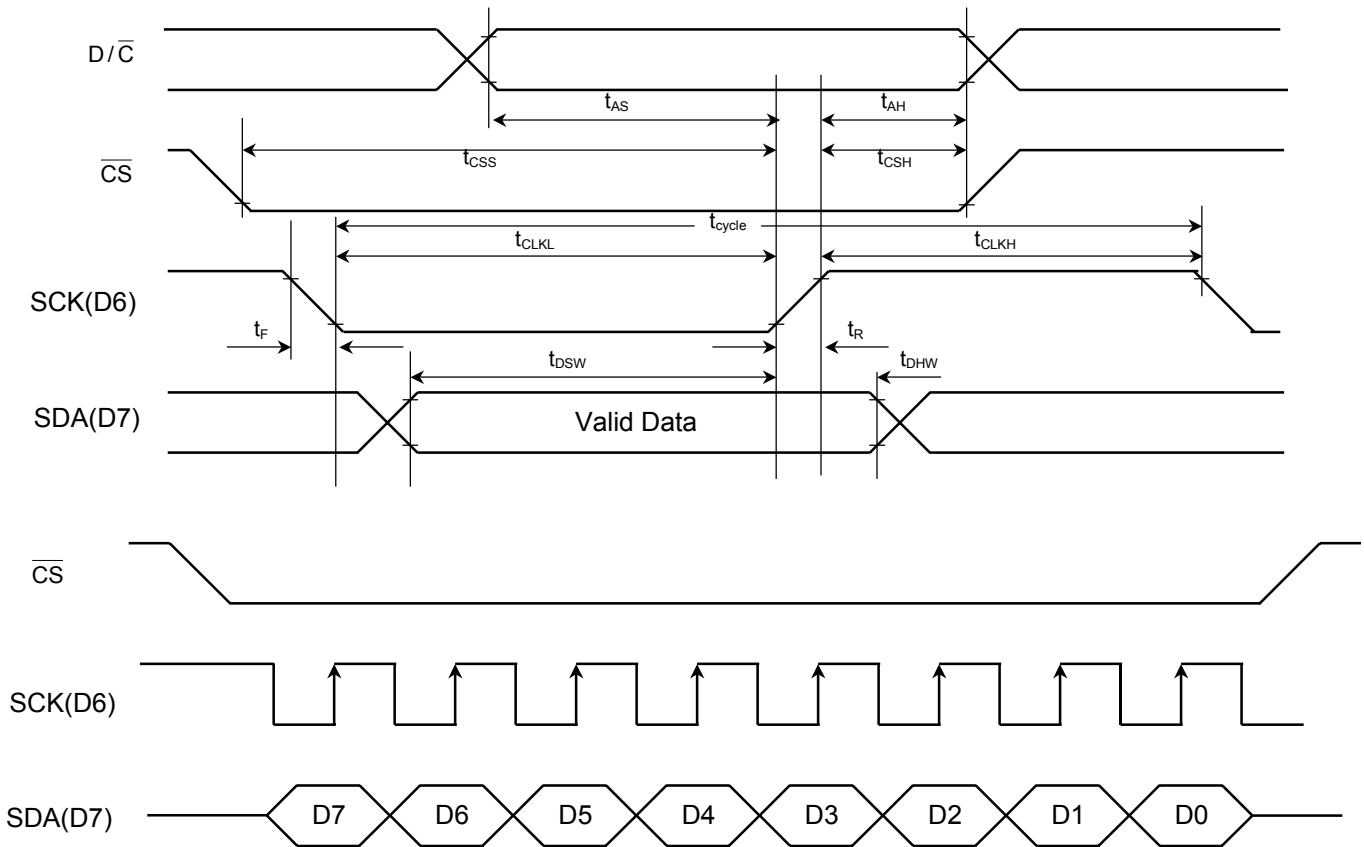

Figure 16 - 4-wires Serial Interface Timing Characteristics (P/S = L, C68/80 = L)

13 APPLICATION EXAMPLES

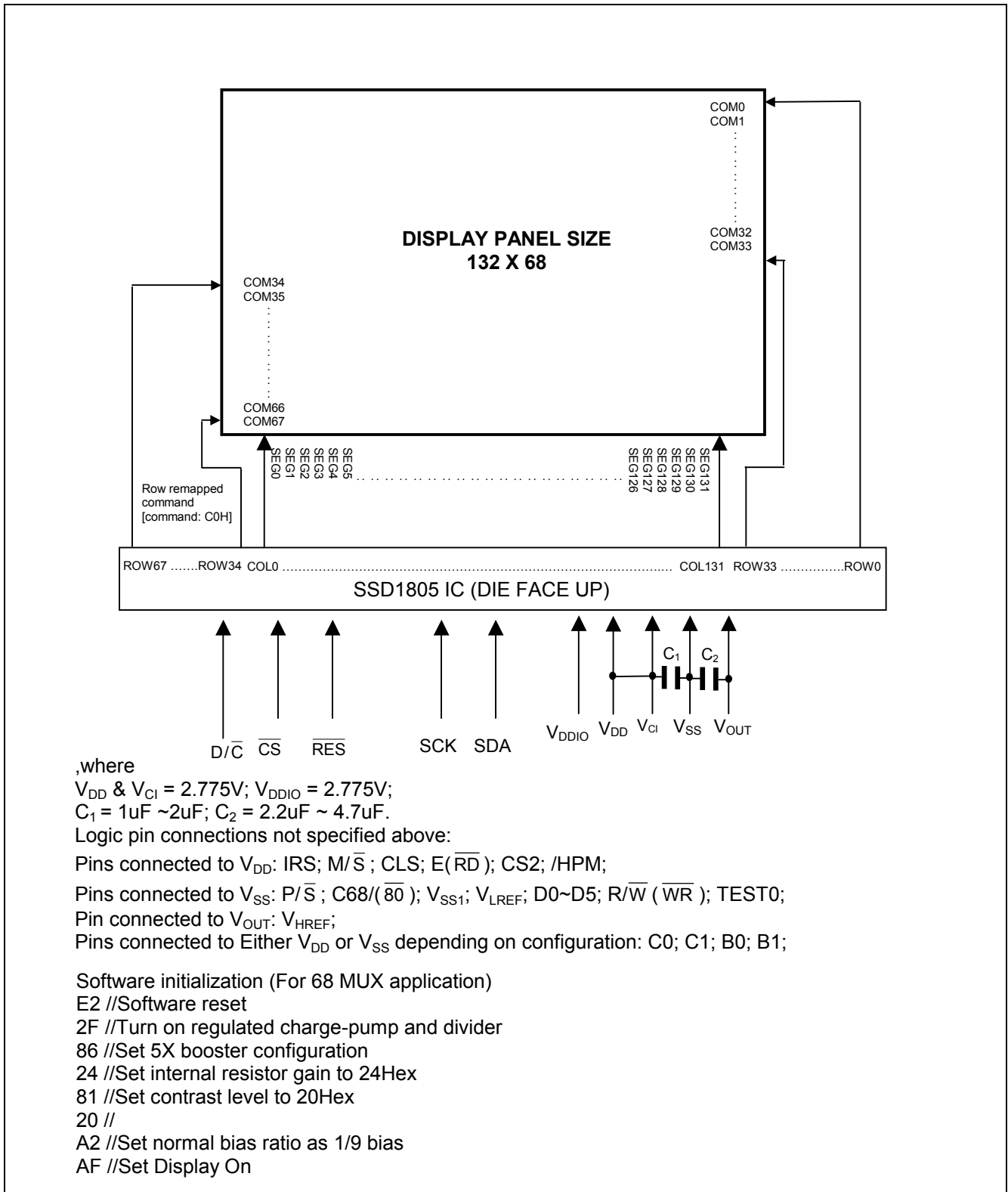

Figure 17 - Application Example I (4-wires SPI mode)

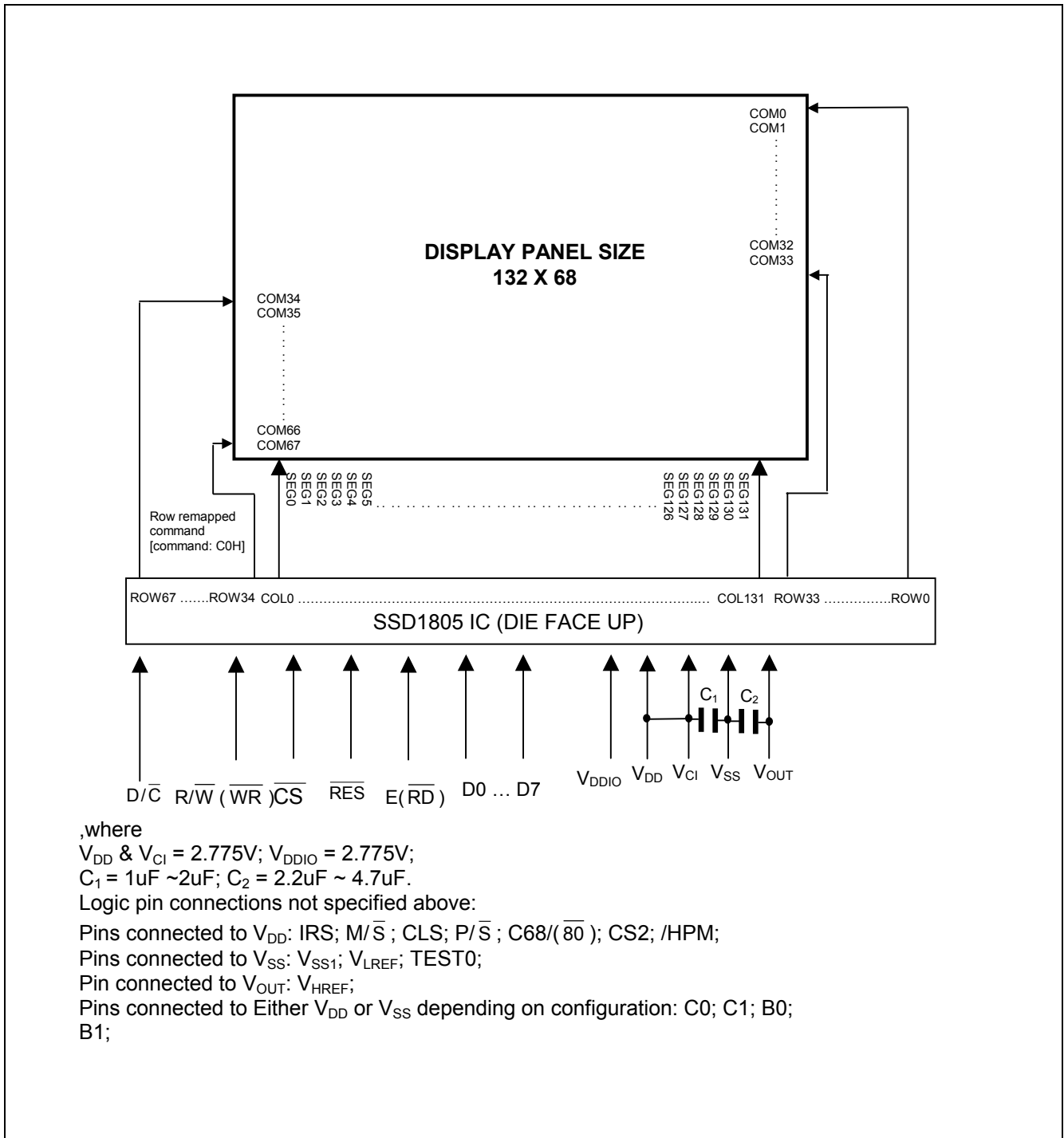
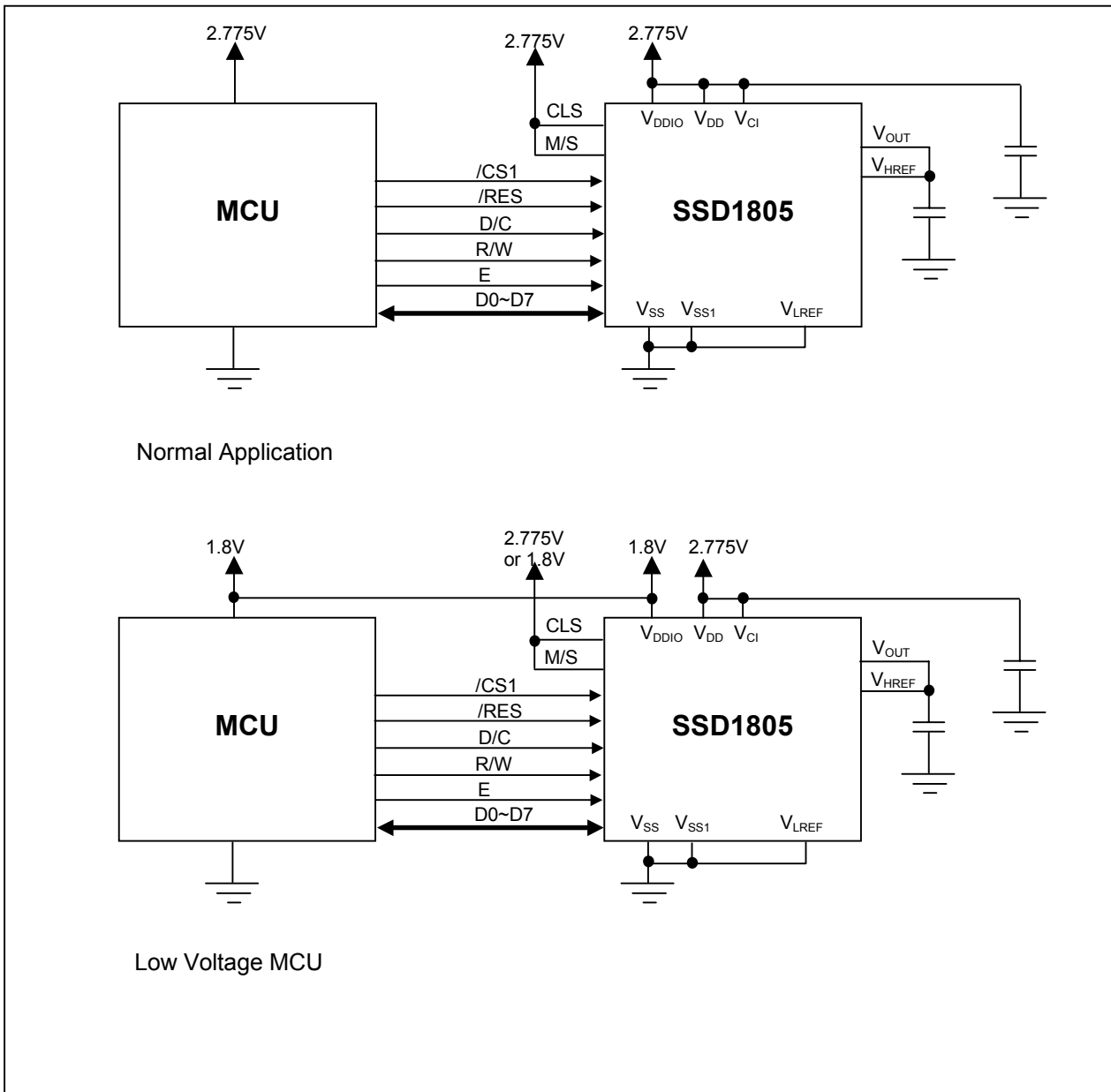

Figure 18 - Application Example II (6800 PPI mode)

Figure 19 - Applications notes for V_{DD}/V_{DDIO} connection



14 PACKAGE INFORMATION

14.1 DIE TRAY DIMENSIONS

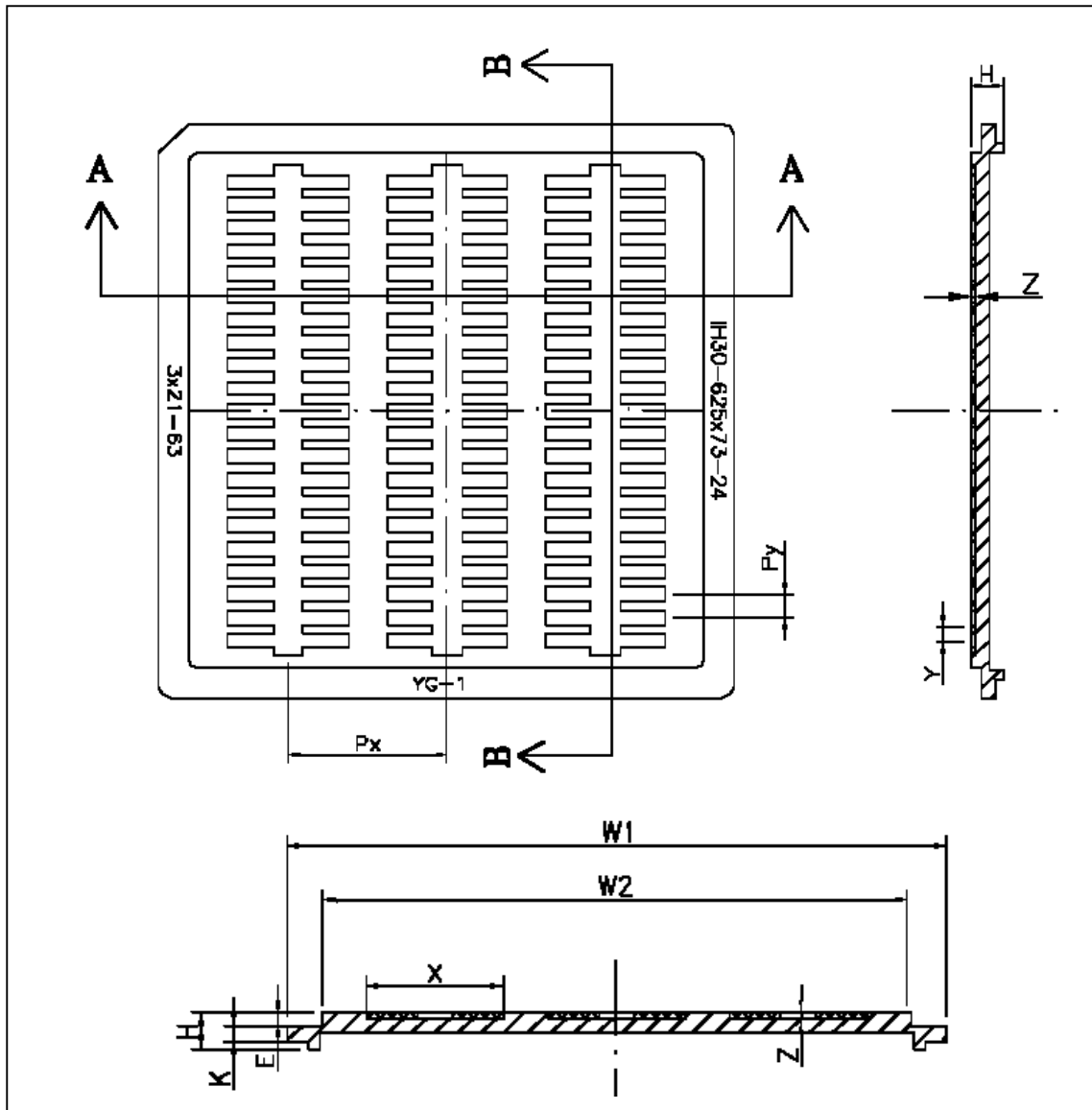

Spec	mm	(mil)
W1	50.70 ± 0.2	(1996)
W2	45.50 ± 0.2	(1791)
H	4.05 ± 0.2	(160)
K	N/A	
E	N/A	
Px	14.19 ± 0.1	(559)
Py	2.48 ± 0.1	(98)
X	11.26 ± 0.1	(443)
Y	1.41 ± 0.1	(58)
Z	0.68 ± 0.05	(27)
N	51	

14.2 TAB DRAWING

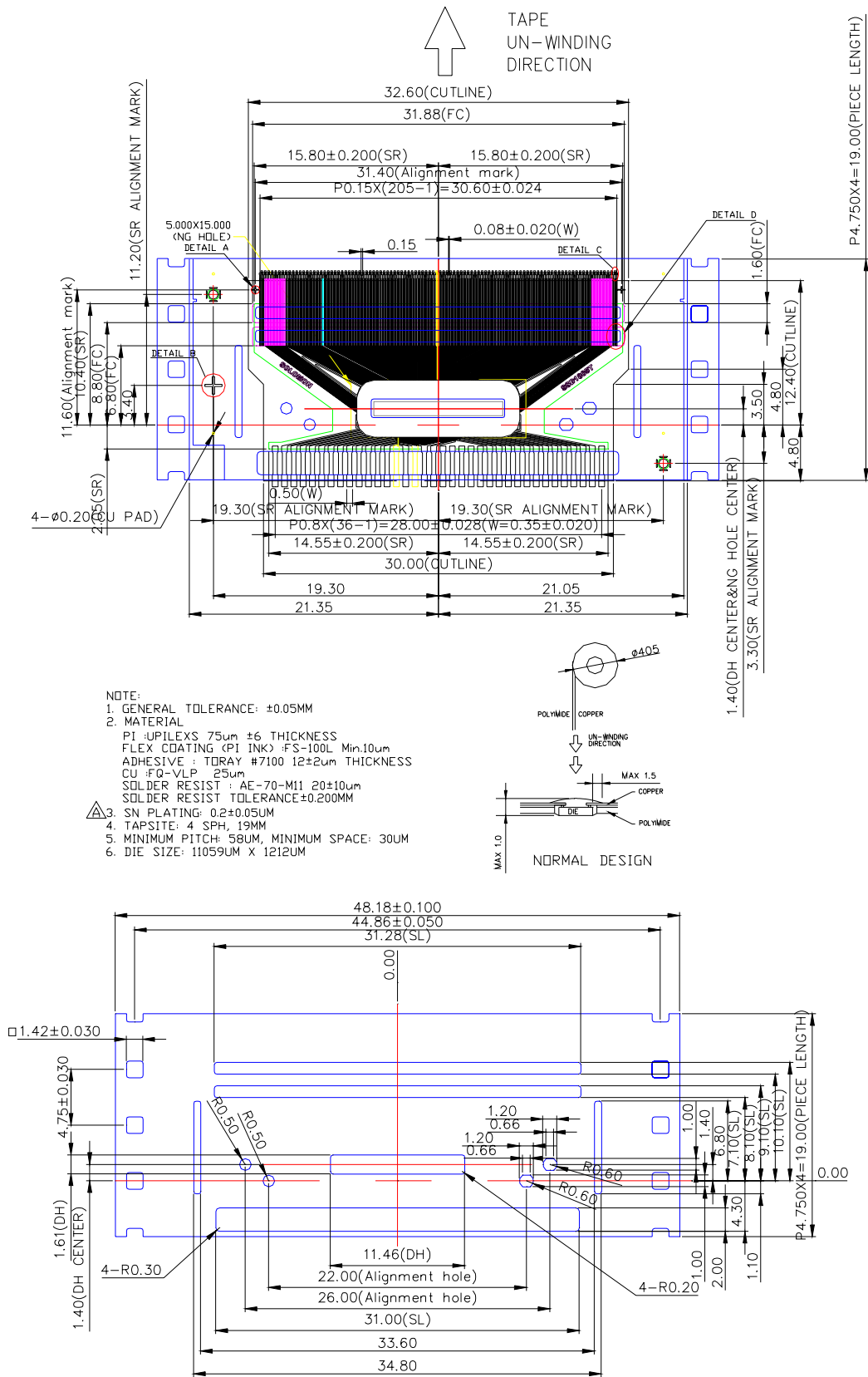
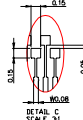
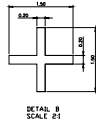
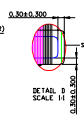
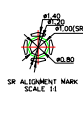
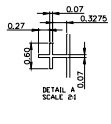
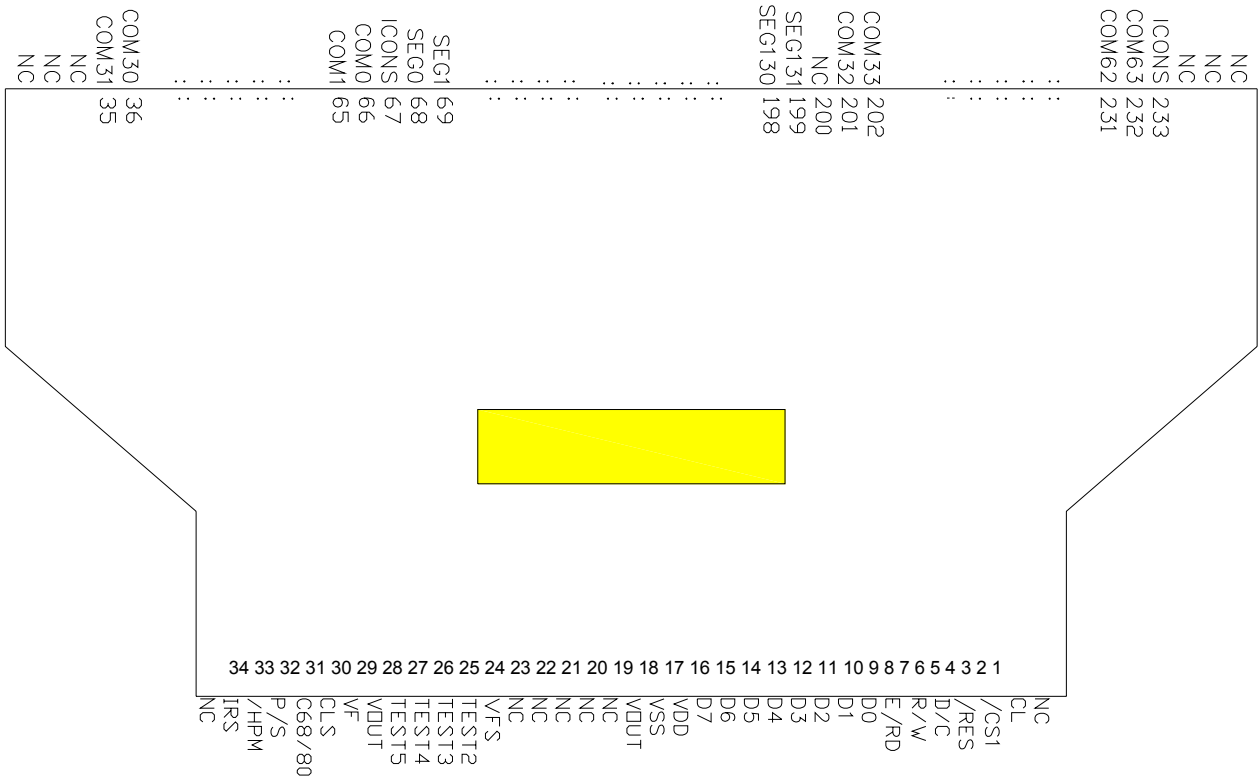

Figure 20 - SSD1805TR1 TAB Drawing (Copper view)



POLYIMIDE VIEW



Solomon Systech reserves the right to make changes without further notice to any products herein. Solomon Systech makes no warranty, representation or guarantee regarding the suitability of its products for any particular purpose, nor does Solomon Systech assume any liability arising out of the application or use of any product or circuit, and specifically disclaims any and all liability, including without limitation consequential or incidental damages. "Typical" parameters can and do vary in different applications. All operating parameters, including "Typicals" must be validated for each customer application by customer's technical experts. Solomon Systech does not convey any license under its patent rights nor the rights of others. Solomon Systech products are not designed, intended, or authorized for use as components in systems intended for surgical implant into the body, or other applications intended to support or sustain life, or for any other application in which the failure of the Solomon Systech product could create a situation where personal injury or death may occur. Should Buyer purchase or use Solomon Systech products for any such unintended or unauthorized application, Buyer shall indemnify and hold Solomon Systech and its offices, employees, subsidiaries, affiliates, and distributors harmless against all claims, costs, damages, and expenses, and reasonable attorney fees arising out of, directly or indirectly, any claim of personal injury or death associated with such unintended or unauthorized use, even if such claim alleges that Solomon Systech was negligent regarding the design or manufacture of the part

<http://www.solomon-systech.com>