

Features

- RoHS compliant for all six substances
- Wide input voltage range (90-264 VAC) with PFC
- High power density, 9 Watts/cubic inch
- 1U or 2U height configurations
- Active current share with ORing FET
- I²C interface status and control
- Standby voltage of 3.3 VDC @ 3 A
- Overtemperature, overload, and overvoltage protection
- Status LEDs: AC OK, DC OK, Overtemperature

Applications

- Datacom
- Distributed power systems

Description

The SFP450-12BG is a 450-watt, power factor corrected (PFC) front-end which provides a 12 VDC output for datacom and other distributed power applications. Its compact size enables mounting in both 1U and 2U height racks. High efficiencies, advanced thermal management techniques, and an internal fan increase reliability over a broad range of operating conditions. Internal ORing diodes facilitate use in hot-swap, redundant configurations.

Status is provided with front panel LEDs, logic signals, and via the I²C management interface bus. In addition, the I²C bus can enable the power supply and control fan speed.

The SFP450-12BG meets international safety requirements and is CE marked to the Low Voltage Directive (LVD).

Model Selection

| Model | Nominal Output Voltage (VDC) | Adjustment Range (VDC) | Maximum Output Current (Amps) | Regulation % | Ripple & Noise @ 20 MHz BW (mV) |
|-------------|------------------------------|------------------------|-------------------------------|--------------|---------------------------------|
| SFP450-12BG | 12 3.3 (Standby) | N/A N/A | 36.6 3 | ±3 ±3 | 100 100 |

SFP450-12BG AC-DC Front-End Data Sheet
12V Output, 450 Watts



Input Specifications

| Parameter | Conditions/Description | Min. | Nom. | Max. | Units |
|----------------------|---|--------|------|------|-------|
| AC Input Voltage | Single-phase continuous input range. | 90 | | 264 | VAC |
| Input Frequency | AC input. | 47 | | 63 | Hz |
| Hold-up Time | After last AC line peak at full power. At 115 VAC. | 20 | | | ms |
| Input Current | At full-rated load. At 90 VAC. | | | 6 | A rms |
| Inrush Surge Current | Excluding Xcap. Vin = 264 VAC. 25 °C | | | 15 | A pk |
| Power Factor | Per EN61000-3-2 | > 0.95 | | | W/VA |

Output Specifications

| Parameter | Conditions/Description | Min. | Nom. | Max. | Units |
|---------------------------------|--|------|------|------|-------|
| Efficiency | Full rated load at 220 VAC input. | 89 | | | % |
| Minimum Load | Minimum loading required to maintain regulation. | 0 | | | A |
| Output Power | | | | 450 | W |
| Overshoot | Output voltage overshoot at turn-on. | | | < 5 | % |
| Transient Response | Maximum recovery time to within 1% of initial set point due to a 25% load change, 1A/μs. 12V output: Standby output: | | | 5 | ms |
| | | | | 5 | ms |
| | Maximum deviation: 12V output: Standby output: | | | 3 | % |
| | | | | 3 | % |
| Turn-On Delay with PS_ON signal | Time required for initial output voltage stabilization after application of AC input or ON/OFF signal. | | | 1500 | ms |
| Output Regulation | See Model Selection data on page 1. | | | | |

Interface Signals and Internal Protection¹

| Parameter | Conditions/Description | Min. | Nom. | Max. | Units |
|---|--|-------------|------|-----------|-------|
| Overvoltage Protection | Latch-style overvoltage protection. | | | 15 4.3 | V |
| Overcurrent Protection | Current limit (Latching Mode). 12V output: Standby output: | 38.4 3.2 | | 47.6 6 | A |
| Short-Circuit Protection | Latching Mode. | | | | |
| Overtemperature/ Fan Failure Warning | 12V output will shut down in the event of an overtemperature condition or blocked fan rotor. OT setpoint is 62 ±3 °C. Supply's fan and Vaux are active. Power supply will recover when OT condition is removed. Amber OT LED will turn ON to indicate fault condition. | | | | |
| PS_KILL | Output enable. Pulled low on conjunction with PS_ON being pulled low allows V1 to be activated. | | | | |
| +12V Current Share | 0 to 8V signal used for active current sharing. | | | | |
| Write Protect | For factory use only. | | | | |
| PS A0 | I ² C Address. | | | | |
| SDA | I ² C Data line (3.3V). | | | | |
| SCL | I ² C Clock line (3.3V). | | | | |
| Tach | Two pulses per fan revolution. | | | | |
| AC_OK/H | High signal indicates AC is within PSU limits. | | | | |
| Present/L | 100 Ohm resistor internally connected to RTN allowing the PSU to be detected on insertion. | | | | |
| Alert/L | Low signal indicates PSU fan is running below speed or an overtemperature limit was exceeded. | | | | |
| PWROK/H | High signal indicates both outputs are within regulation limits. | | | | |

¹ Refer to product specification for internal pull up impedances and timing of these signals.

I²C Bus Management Interface¹

| | |
|------------------------------|---|
| Static | Includes static information such as: part number and revision level, output rating, serial number, date code, and manufacturing location. |
| Status (Logic 1 or 0) | AC Input OK. DC Output OK. Overtemperature. Overcurrent. Fan OK. Overvoltage Alert Undervoltage Alert |
| Real-Time Monitoring | Output voltage (main output). LSB = 20 mV Output current (main output). LSB = 50 mA |

¹ Reference "I²C Management Interface" and "EEPROM Table of Contents" documents for SFP450-12BG (consult factory).

Safety, Regulatory, and EMI Specifications

| Parameter | Conditions/Description | Min. | Nom. | Max. | Units |
|---------------------------------|---|--|------|------|-----------------|
| Agency Approvals | UL60950, (UL) CSA 60950 (cUL), EN60950 (TÜV), CE Mark for LVD. | | | | |
| Electromagnetic Interference | FCC CFR title 47 Part 15 Sub-Part B, EN55022/CISPR 22. | Conducted: A Radiated: A | | | Class |
| Harmonics | Per IEC61000-3-2. | A | | | Class |
| Voltage Fluctuation and Flicker | Per IEC61000-3-3. | Pass | | | |
| ESD Susceptibility | Per EN61000-4-2, Level 4. | 8 | | . | kV |
| Radiated Susceptibility | Per EN 61000-4-3, Level 3. | 10 | | . | V/M |
| EFT/Burst | Per EN 61000-4-4, Level 4. | ±4 | | . | kV |
| Input Transient Protection | Per EN 61000-4-5, Class 3. | Line-to-Line: 1 Line-to-Ground: 2 | | . | kV |
| RF Conducted Disturbances | Per EN 61000-4-6, Level 3. | 10 | | . | V |
| Voltage Interruptions | Per EN 61000-4-11, performance criterion B 30%. Per EN 61000-4-11, performance criterion C 60%. Per EN 61000-4-11, performance criterion C 95%. | 10 100 5 | | . | ms ms Sec |
| Voltage Sag Immunity | Per SEMI F47-0999 > 100 VAC. No output voltage interruption. | | | . | |
| Leakage Current | Per EN60950. | At 240 VAC: | | | 1.75 mA |

Environmental Specifications

| Parameter | Conditions/Description | Min. | Nom. | Max. | Units |
|-------------------------|--|------|------|------------|------------------|
| Altitude | Operating. Non-Operating. | | | 10K 40K | ASL ft ASL ft |
| Operating Temperature | Internal DC fan for cooling. At 100% load: | 0 | | 50 | °C |
| Storage Temperature | | -40 | | 85 | °C |
| Temperature Coefficient | 0 °C to 45 °C (after 15-minute warm-up). | | | 0.02 | %/°C |
| Relative Humidity | Non-condensing. | | | 95 | %RH |
| Shock | Operating: half-sine, 10 ms, 3-axis. | | | +20 | Gpk |
| | Non-Operating: half-sine, 10 ms, 3-axis. | | | +40 | Gpk |
| Vibration | Operating: swept sine 5-2000-5 Hz, 5-32 Hz, 0.02iDA, 32-2000 Hz. | | | 1 | Gpk |
| | Non-operating: random 10-2000 Hz. | | | 6.15 | Grms |

Reliability

| Parameter | Conditions/Description | Min. | Nom. | Max. | Units |
|-----------|--|---------|------|------|-------|
| MTBF | (Calculated) MILHDBK 217F Ground Benign. | 100 000 | | | hrs |
| | Demonstrated. | 200 000 | | | hrs |
| | Useful Life. | 10 | | | yrs |

LED Indicators

| Indicator | LED Color |
|------------|------------------------|
| Power Good | GREEN |
| AC OK | GREEN (Input > 85 VAC) |
| FAIL | AMBER |

Mechanical Drawings

Weight: 1.46 kg (3.22 lb)

FRONT VIEW

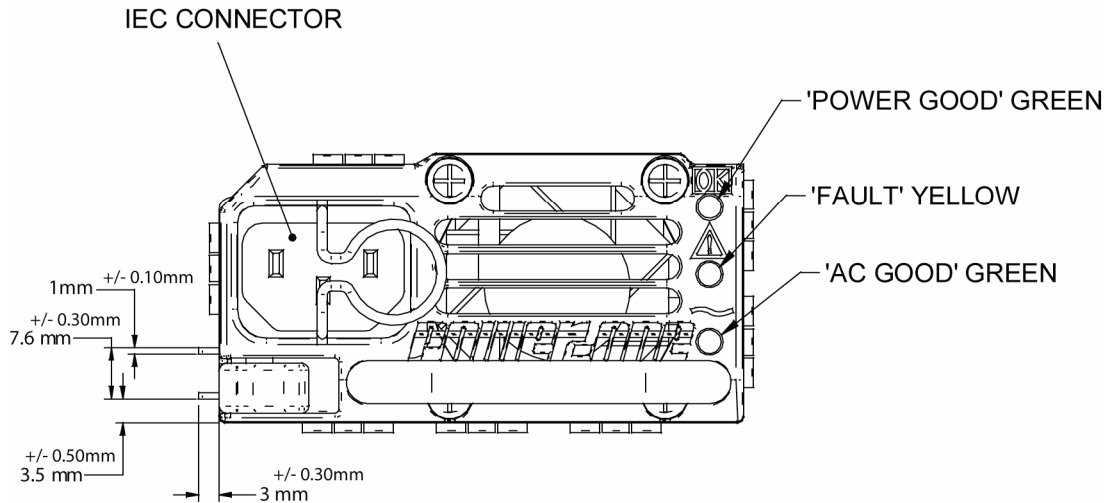

REAR VIEW

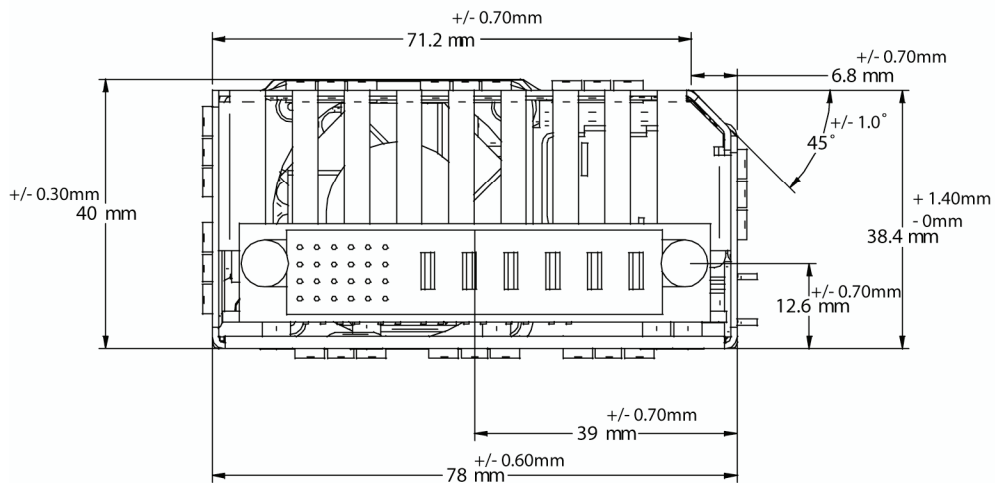

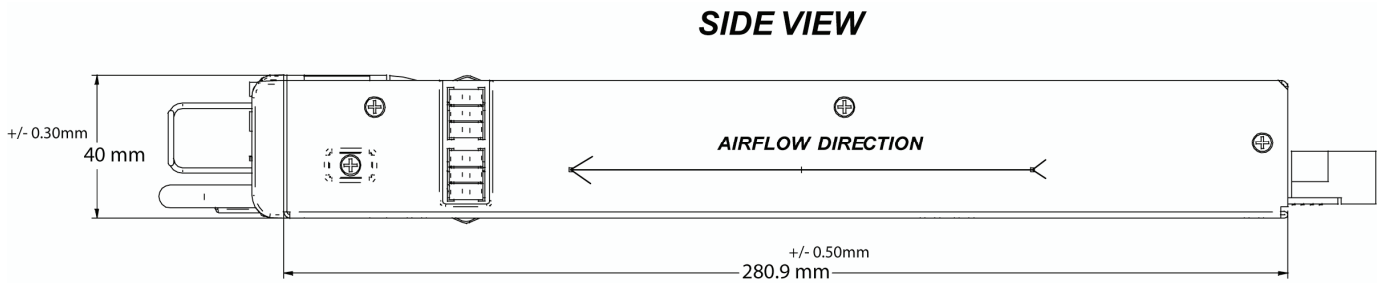
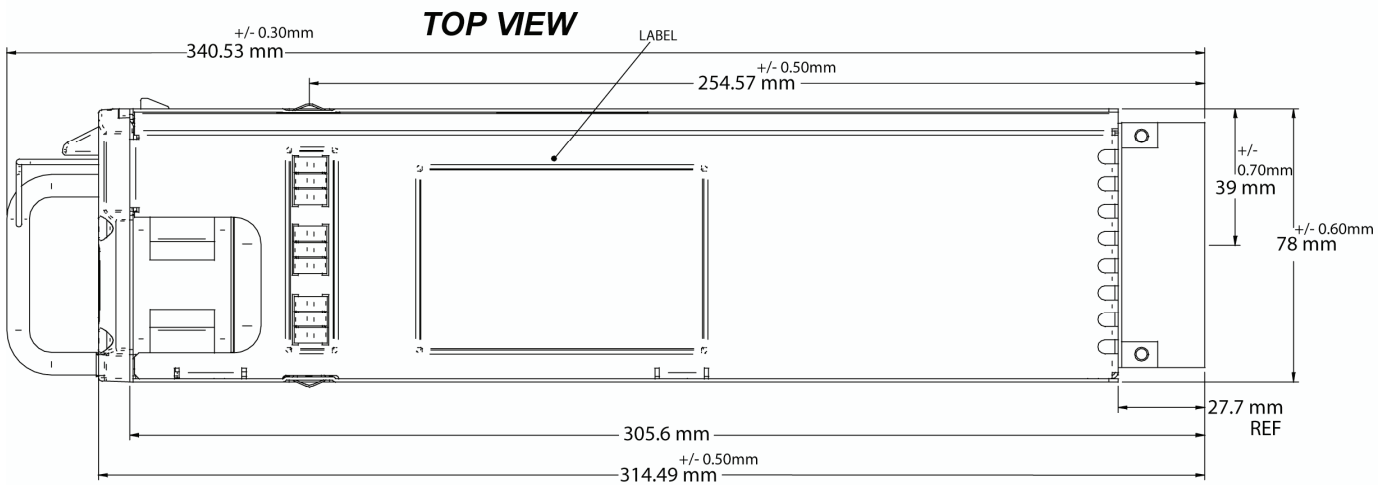

Connector Information

Power Supply:

Input - IEC 320 input (Male) standard line cord connection
Output - P/N FCI 51721-10002406AA or equivalent

Mating Connections:

Input - IEC 320 output (Socket) Standard line cord (15A)
Output - P/N: FCI 51741-10002406CC

Input IEC Connector

| Input | Location |
|-------------------------|----------|
| Chassis (Safety) Ground | Ground |
| Line 1 (Line) | L |
| Line 2 (Neutral) | N |

OUTPUT CONNECTOR:

FCI (POWER BLADE)
51721-10002406AC

| | |
|---|------------------------------|
| WILL MATE WITH SYSTEM BOARD CONNECTOR: | |
| FCI (POWER BLADE) 5174-10002406AA 5174-10002406BA 5174-10002406CB | STRAIGHT IN CONNECTOR |
| FCI (POWER BLADE) 51761-10002406AA 51761-10002406BA 51761-10002406CB | RIGHT ANGLE CONNECTOR |

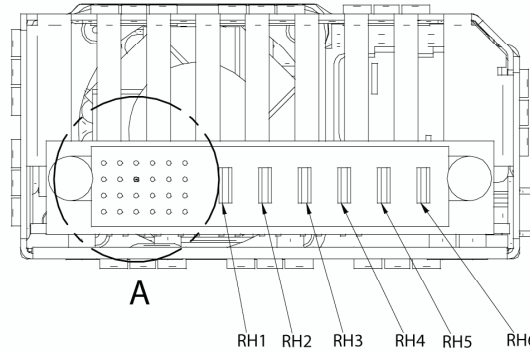

| PIN | SIGNAL NAME |
|-----|--------------------|
| RH1 | +12V Return |
| Rh2 | +12v Return |
| Rh3 | +12v Return |
| Rh4 | +12v |
| Rh5 | +12v |
| Rh6 | +12v |
| A1 | PS KILL |
| A2 | +12v Current Share |
| A3 | RETURN |
| A4 | Write Protect |
| A5 | PS A0 |
| A6 | +3.3V SB |
| B1 | RETURN |
| B2 | Spare |
| B3 | RETURN |
| B4 | +3.3v SB |
| B5 | SDA |
| B6 | PSON/L |
| C1 | RETURN |
| C2 | Tach 1 |
| C3 | RETURN |
| C4 | +3.3v SB |
| C5 | SCL |
| C6 | ACOK/L |
| D1 | Present/L |
| D2 | Spare |
| D3 | RETURN |
| D4 | +3.3V SB |
| D5 | Alert/L |
| D6 | PWROK/H |

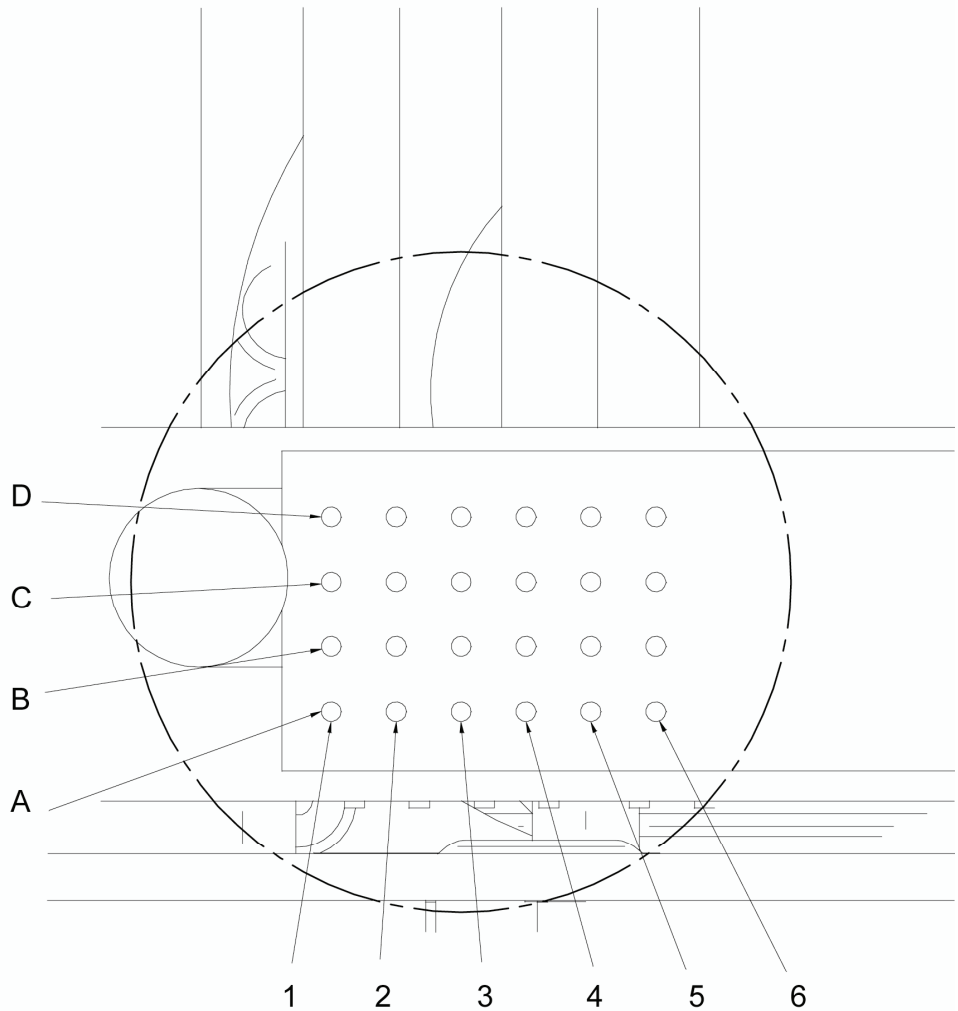

DETAIL A

SFP450-12BG AC-DC Front-End Data Sheet
12V Output, 450 Watts



| | |
|--|------------------------------|
| WILL MATE WITH SYSTEM BOARD CONNECTOR: | |
| FCI (POWER BLADE) 5174-10002406AA 5174-10002406BA 5174-10002406CB | STRAIGHT IN CONNECTOR |
| FCI (POWER BLADE) 51761-10002406AA 51761-10002406BA 51761-10002406CB | RIGHT ANGLE CONNECTOR |

FCI 51761-10002406
 FCI 5174-10002406 A A
 B A
 C B

"A" = .135 +/- .010 (3.43 +/- 0.25) SOLDER TO BOARD.
 "B" = .090 +.005 / -.010 (2.29 +0.13 / -0.25) SOLDER TO BOARD
 "C" = .154 +/- .010 (3.91 +/- 0.25) PRESS FIT TO BOARD

"A" = BOARD LOCK (REQUIRES .098 +.002/- .001 (2.49 +0.05/ -0.03) THRU HOLE IN PCB
 MOUNTING FOOT HEIGHT: .220 (5.59)
 ** NOT AVAILABLE FOR PRESS FIT **
 "B" = .150 (3.81) THRU HOLE (REQUIRES .158 +/- 0.003 (4.01 +/- 0.08) THRU HOLE IN PCB).
 MOUNTING FOOT HEIGHT .160 (4.06)
 ** ALWAYS FOR PRESS FIT **

NUCLEAR AND MEDICAL APPLICATIONS - Power-One products are not designed, intended for use in, or authorized for use as critical components in life support systems, equipment used in hazardous environments, or nuclear control systems without the express written consent of the respective divisional president of Power-One, Inc.

TECHNICAL REVISIONS - The appearance of products, including safety agency certifications pictured on labels, may change depending on the date manufactured. Specifications are subject to change without notice.