

## Dual bridge audio amplifier for car radio

### Features

- Minimum external component count
- No bootstrap capacitors
- No Boucherot cells
- Clip detector output
- High output power
- Fixed gain
- Very low stand-by current (1  $\mu$ A typ)
- No switch on/off noise

### Protections

- Output AC/DC short circuit to GND and to  $V_S$
- Very inductive loads
- Overtating chip temperature
- Load dump voltage
- Fortuitous open GND
- Reverse battery
- ESD

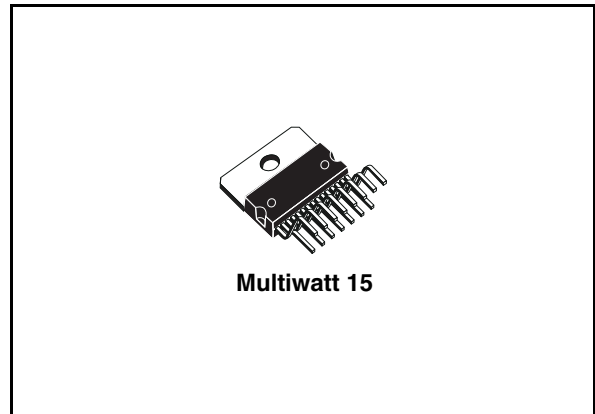

### Description

The TDA7374 is a class AB audio dual bridge power amplifier in Multiwatt package designed for car radio applications.

Thanks to the fully complementary PNP/NPN output configuration the high power performances of the TDA7374 are obtained without bootstrap capacitors.

**Table 1. Device summary**

Order code	Package	Packing
TDA7374BV	Multiwatt 15	Tube

# Contents

- 1        Block diagram and pins connections diagram ..... 5**
  
- 2        Electrical specifications ..... 6**
  - 2.1    Absolute maximum ratings ..... 6
  - 2.2    Thermal data ..... 6
  - 2.3    Electrical characteristics ..... 7
  - 2.4    Electrical characteristics curves ..... 9
  
- 3        Output stage ..... 11**
  - 3.1    Rail-to-rail output voltage swing with no need of bootstrap capacitors ... 11
  - 3.2    Absolute stability without any external compensation ..... 11
  - 3.3    Other outstanding characteristics ..... 12
    - 3.3.1    Clipping detector output ..... 12
    - 3.3.2    Offset control ..... 12
    - 3.3.3    Gain internally fixed to 26dB ..... 12
    - 3.3.4    Silent turn on/off and muting/stand-by function ..... 12
  - 3.4    Built-in protection systems ..... 13
    - 3.4.1    Full protection of device and loudspeakers against AC/DC short circuits  
          (to Gnd, to  $V_s$ , across the speakers) 13
    - 3.4.2    Load dump voltage surge ..... 13
    - 3.4.3    Polarity inversion ..... 13
    - 3.4.4    Open ground ..... 14
    - 3.4.5    Inductive load ..... 14
    - 3.4.6    DC voltage ..... 14
    - 3.4.7    Thermal shut-down ..... 14
    - 3.4.8    Loudspeaker protection ..... 14
  - 3.5    Clipping detector ..... 15
  - 3.6    What is needed for a demonstration ..... 15
    - 3.6.1    General Information ..... 16
  
- 4        Package information ..... 17**
  
- 5        Revision history ..... 18**

## List of tables

Table 1.	Device summary . . . . .	1
Table 2.	Absolute maximum ratings . . . . .	6
Table 3.	Thermal data . . . . .	6
Table 4.	Electrical characteristics . . . . .	7
Table 5.	Document revision history . . . . .	18

## List of figures

Figure 1.	Block diagram . . . . .	5
Figure 2.	Pin connection (top view) . . . . .	5
Figure 3.	Test and application circuit . . . . .	8
Figure 4.	Printed board and component layout of the <i>Figure 3.</i> . . . . .	8
Figure 5.	Quiescent drain current vs. supply voltage . . . . .	9
Figure 6.	Quiescent output voltage vs. supply voltage . . . . .	9
Figure 7.	Output power vs. supply voltage . . . . .	9
Figure 8.	Distortion vs. output power . . . . .	9
Figure 9.	Output power vs. frequency . . . . .	9
Figure 10.	Supply volt. rejection vs. frequency for a different values of C6 capacitor . . . . .	9
Figure 11.	Cross-talk vs. frequency . . . . .	10
Figure 12.	En input vs. Rg . . . . .	10
Figure 13.	Stand-by attenuation vs. threshold voltage . . . . .	10
Figure 14.	Stand-by attenuation vs. input voltage . . . . .	10
Figure 15.	Clipping detector average current (pin 10) vs. distortion . . . . .	10
Figure 16.	Total power dissipation and efficiency vs. output power . . . . .	10
Figure 17.	The new output stage . . . . .	11
Figure 18.	Clipping detection waveforms . . . . .	12
Figure 19.	A suggested LC network . . . . .	13
Figure 20.	Voltage pulse train on pins 3 and 13 . . . . .	13
Figure 21.	Maximum allowable power dissipation vs. ambient temperature . . . . .	14
Figure 22.	Clipping detector control routine . . . . .	15
Figure 23.	Application with TDA7302 + TDA7374 . . . . .	16
Figure 24.	Multiwatt 15 mechanical data and package dimensions . . . . .	17

# 1 Block diagram and pins connections diagram

Figure 1. Block diagram

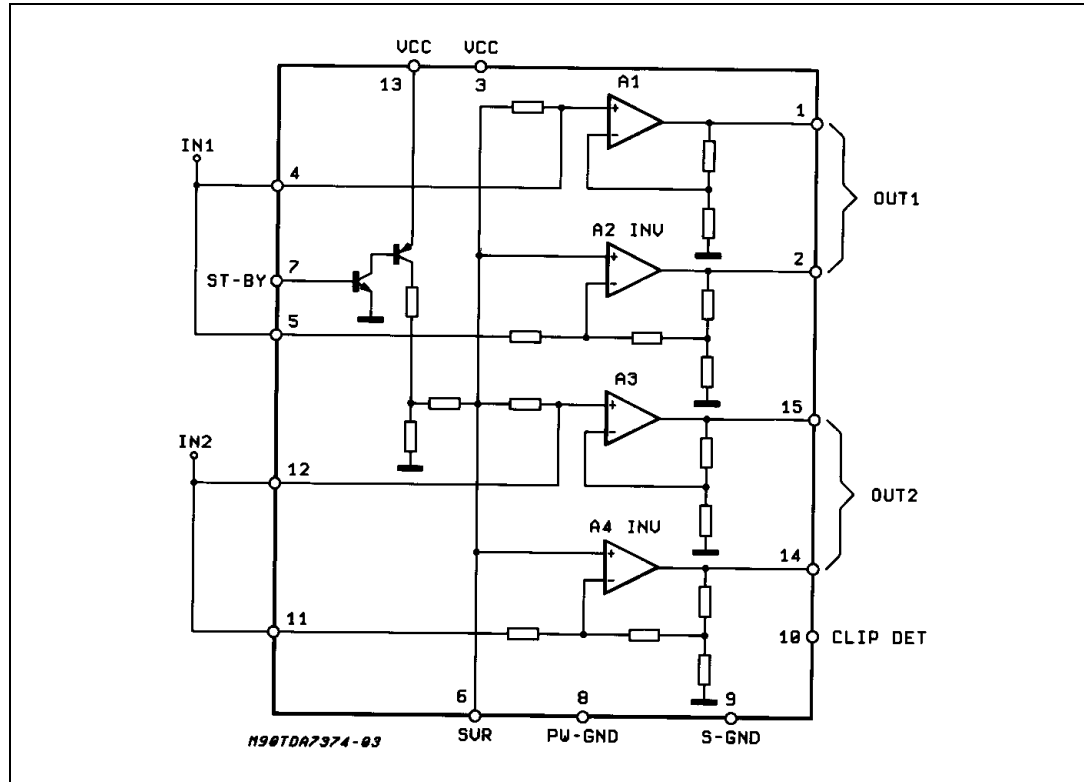
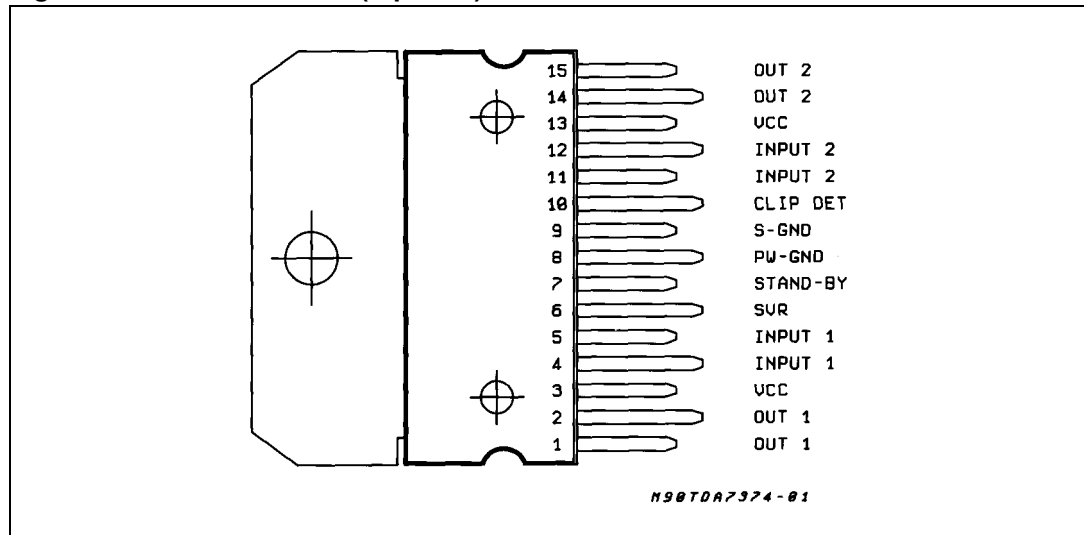

Figure 2. Pin connection (top view)



## 2 Electrical specifications

### 2.1 Absolute maximum ratings

**Table 2. Absolute maximum ratings**

Symbol	Parameter	Value	Unit
$V_S$	DC supply voltage	28	V
$V_{OP}$	Operating supply voltage	18	V
$V_{PEAK}$	Peak supply voltage (t = 50 ms)	50	V
$I_O$	Output peak current (not rep. t = 100 $\mu$ s)	4.5	A
$I_O$	Output peak current (rep. f > 10 Hz)	3.5	A
$P_{tot}$	Power dissipation ( $T_{case} = 85\text{ }^\circ\text{C}$ )	36	W
$T_{stg}, T_j$	Storage and junction temperature	-40 to 150	$^\circ\text{C}$

### 2.2 Thermal data

**Table 3. Thermal data**

Symbol	Parameter	Value	Unit
$R_{th\ j-case}$	Thermal resistance junction to case	max. 1.8	$^\circ\text{C/W}$

## 2.3 Electrical characteristics

**Table 4. Electrical characteristics**

(Refer to the test circuit;  $V_S = 14.4\text{ V}$ ;  $R_L = 4\ \Omega$ ,  $T_{\text{amb}} = 25\text{ }^\circ\text{C}$ ,  $f = 1\text{ kHz}$ , unless otherwise specified)

Symbol	Parameter	Test condition	Min.	Typ.	Max.	Unit
$V_S$	Supply range		8		18	V
$I_d$	Total quiescent drain current				150	mA
$P_O$	Output power	$R_L = 4\ \Omega$ ; THD = 10 %	17	21		W
d	Distortion	$R_L = 4\ \Omega$ ; $P_O = 0.1\text{ to }10\text{ W}$			0.5	%
CT	Cross talk	$f = 1\text{ kHz}$ ; $R_g = 0$		65		dB
		$f = 10\text{ kHz}$ ; $R_g = 0$		55		dB
$R_{IN}$	Input impedance		10			K $\Omega$
$G_V$	Voltage gain				26	dB
$G_V$	Voltage gain match.				1	dB
$E_{IN}$	Input noise voltage	$R_g = 0\text{ to }10\text{ k}\Omega$ ; Weight A		3.5		$\mu\text{V}$
		$R_g = 0\text{ to }10\text{ k}\Omega$ ; 22 Hz to 22 kHz			10	$\mu\text{V}$
SVR	Supply voltage rejection	$R_g = 0$ ; $f = 100\text{ Hz}$	48			dB
		$R_g = 0$ ; $f = 10\text{ kHz}$		55		dB
ASB	Stand-by attenuation		60			dB
$I_{SB}$	Stand-by current consumption			1		$\mu\text{A}$
$V_{SB\text{ ON}}$	Stand-by IN Threshold Voltage				1.5	V
$V_{SB\text{ OFF}}$	Stand-by OUT threshold voltage		3.5			V
$V_{OS}$	Output offset voltage				200	mV
$I_{CD\text{ OFF}}$	Clipping detector "OFF" output average current	THD = 1 % <sup>(1)</sup>		100		$\mu\text{A}$
$I_{CD\text{ ON}}$	Clipping detector "ON" output average current	THD = 10 % <sup>(1)</sup>		190		$\mu\text{A}$

1. Pin 10 pulled-up to 5V with 10k $\Omega$ ;  $R_L = 4\ \Omega$

Figure 3. Test and application circuit

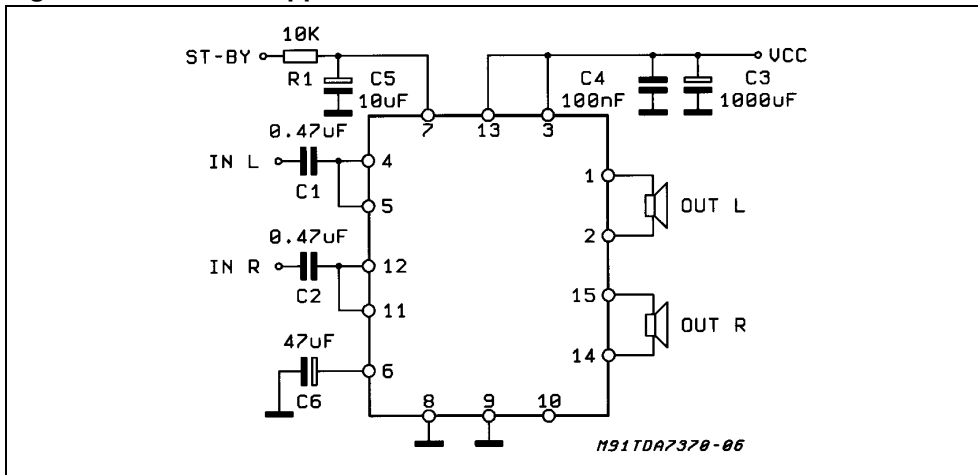
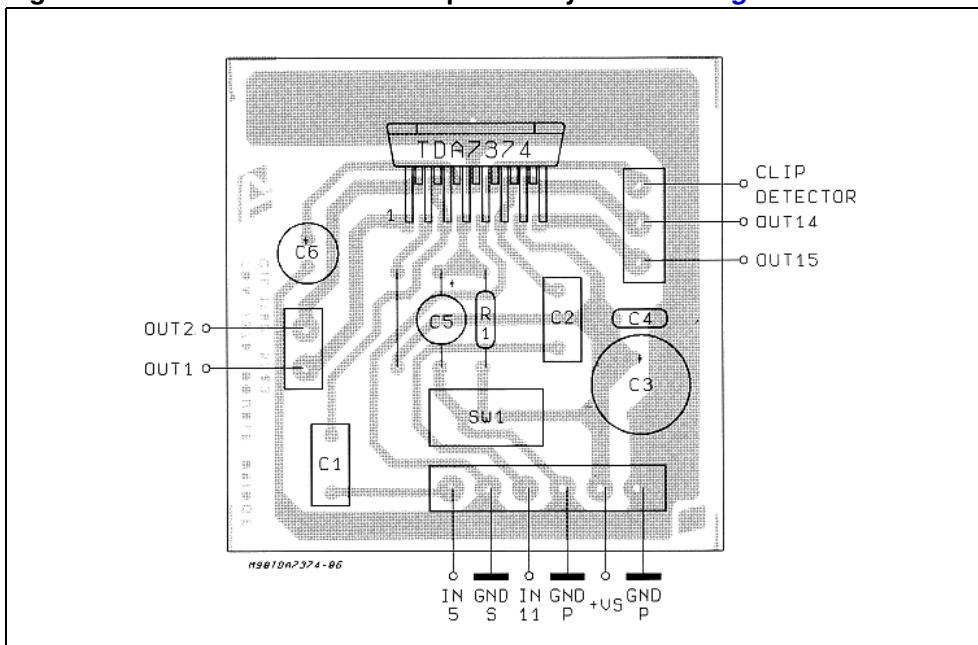

Figure 4. Printed board and component layout of the [Figure 3](#).





## 2.4 Electrical characteristics curves

Figure 5. Quiescent drain current vs. supply voltage

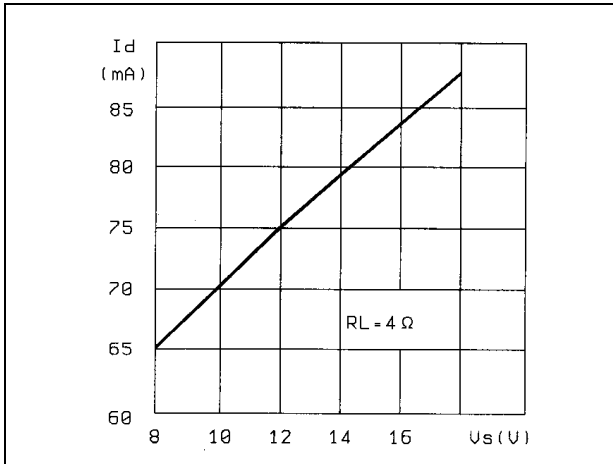

Figure 6. Quiescent output voltage vs. supply voltage

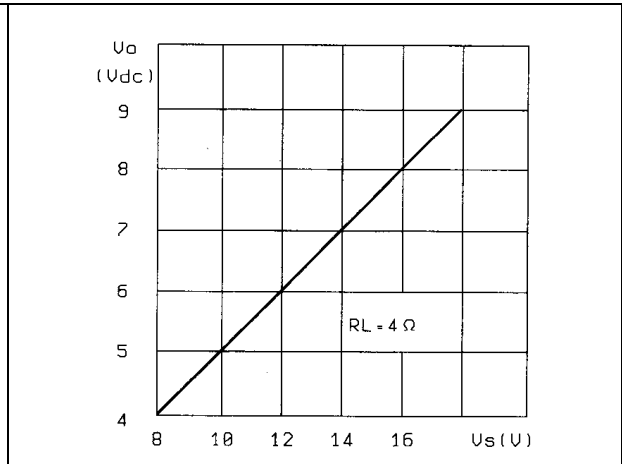

Figure 7. Output power vs. supply voltage

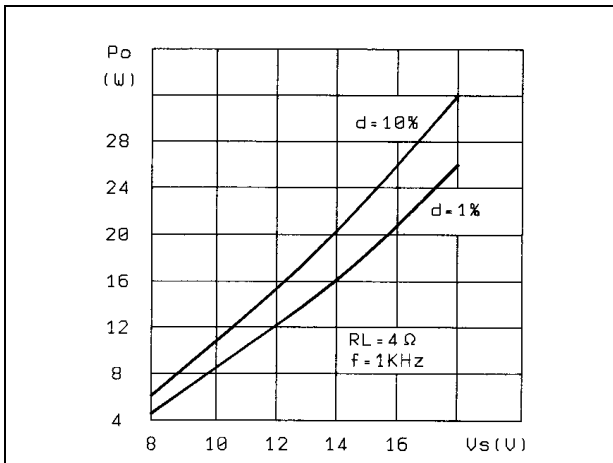

Figure 8. Distortion vs. output power

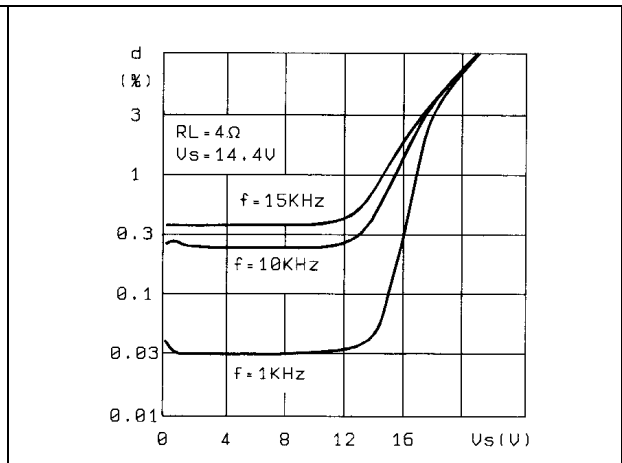

Figure 9. Output power vs. frequency

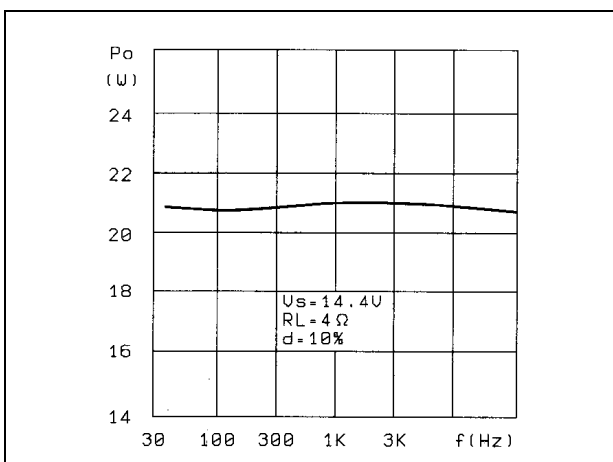

Figure 10. Supply volt. rejection vs. frequency for a different values of C6 capacitor

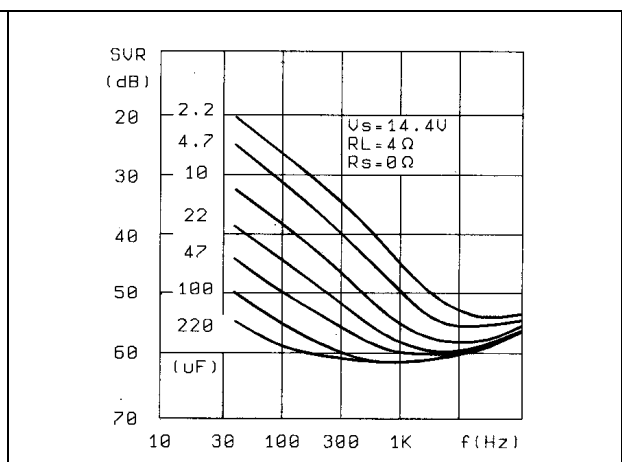

Figure 11. Cross-talk vs. frequency

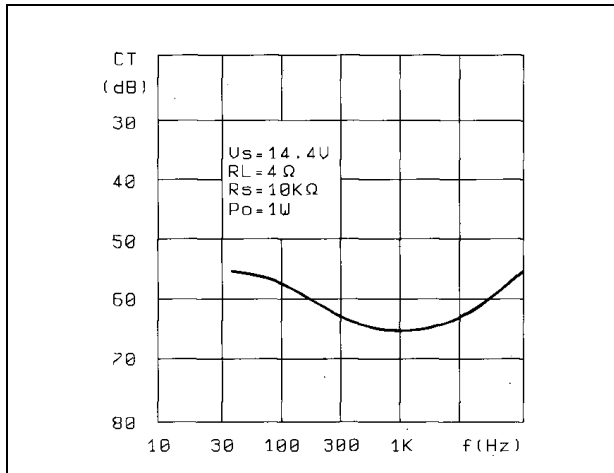

Figure 12. En input vs. Rg

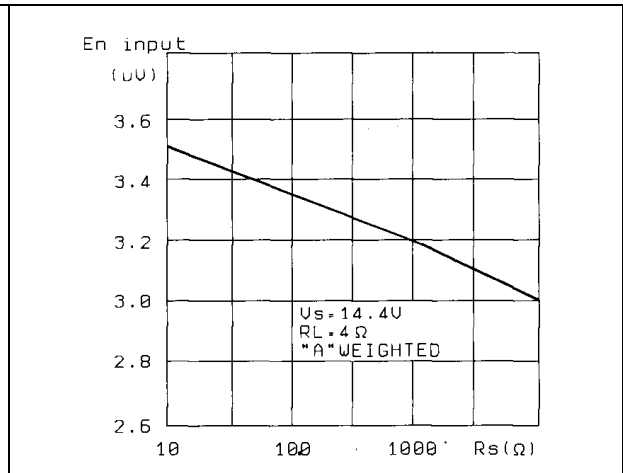

Figure 13. Stand-by attenuation vs. threshold voltage

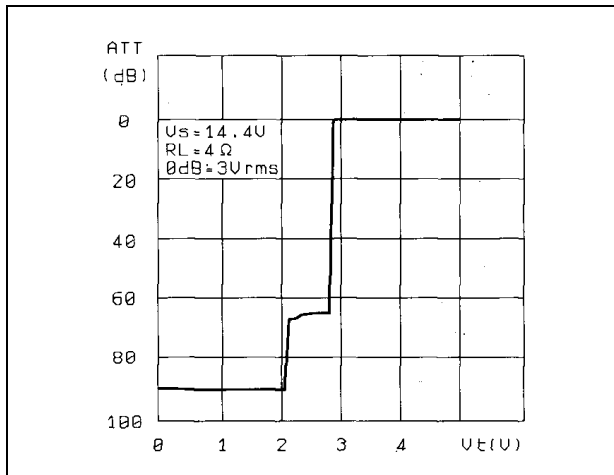

Figure 14. Stand-by attenuation vs. input voltage

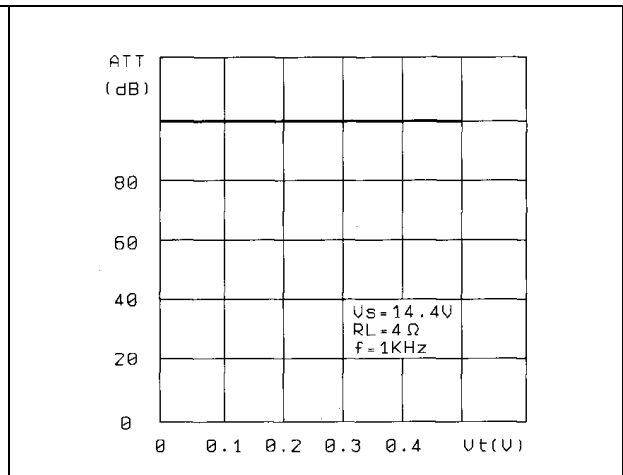

Figure 15. Clipping detector average current (pin 10) vs. distortion

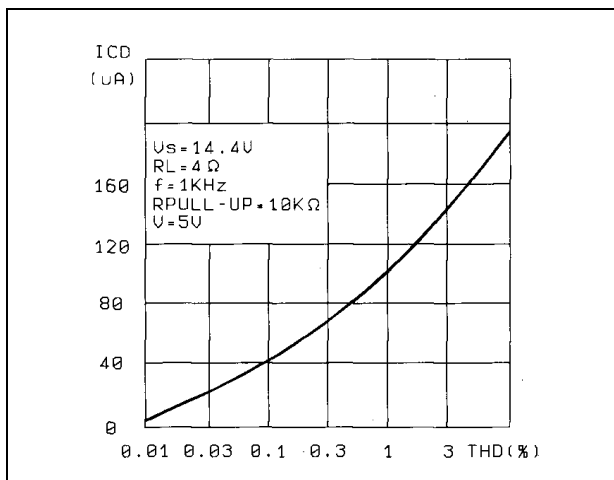
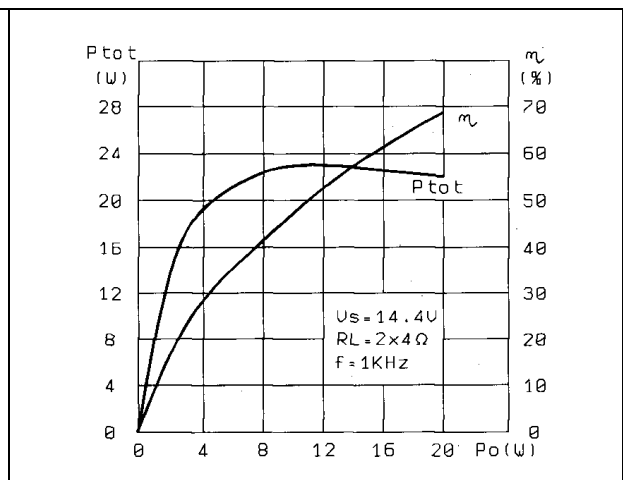

Figure 16. Total power dissipation and efficiency vs. output power



### 3 Output stage

The fully complementary output stage was made possible by the development of a new component: the ST exclusive power ICV PNP.

A novel design based upon the connection shown in [Figure 17](#) has then allowed the full exploitation of its possibilities.

**Figure 17. The new output stage**

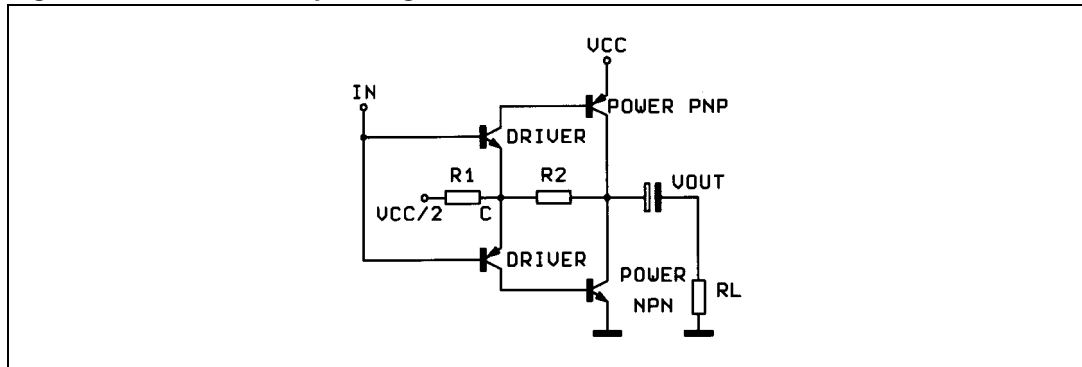

The clear advantages this new approach has over classical output stages are as follows:

#### 3.1 Rail-to-rail output voltage swing with no need of bootstrap capacitors

The output swing is limited only by the  $V_{cesat}$  of the output transistors, which are in the range of  $0.6 \Omega$  each.

Classical solutions adopting composite PNP-NPN for the upper output stage have higher saturation loss on the top side of the waveform. This unbalanced saturation causes a significant power reduction. The only way to recover power consists of the addition of expensive bootstrap capacitors.

#### 3.2 Absolute stability without any external compensation

Referring to the circuit of [Figure 17](#) the gain  $V_{OUT}/V_{IN}$  is greater than unity, approximately  $1 + R2/R1$ . The DC Output ( $V_{CC}/2$ ) is fixed by an auxiliary amplifier common to all the channels).

By controlling the amount of this local feedback it is possible to force the loop gain ( $A * \beta$ ) to less than unity at frequency for which the phase shift is  $180^\circ$ . This means that the output buffer is intrinsically stable and not prone to oscillation.

Most remarkably, the above feature has been achieved in spite of the very low closed loop gain of the amplifier.

In contrast, with the classical PNP-NPN stage, the solution adopted for reducing the gain at high frequencies makes use of external RC networks, namely the Boucherot cells.

### 3.3 Other outstanding characteristics

#### 3.3.1 Clipping detector output

The TDA7374 is equipped with an internal circuit able to detect the output stage saturation providing a proper current sinking into an open collector output (pin 10) when a certain distortion level is reached at each output.

This particular function allows gain compression facility whenever the amplifier is overdriven, thus obtaining high quality sound at all listening levels.

**Figure 18. Clipping detection waveforms**

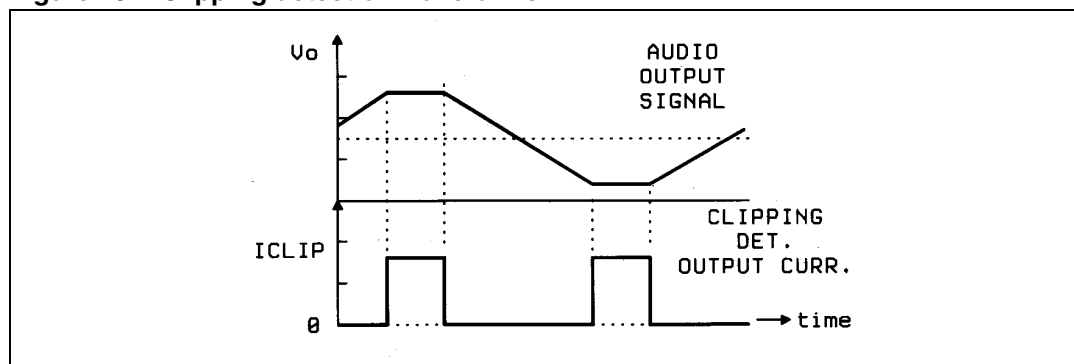

#### 3.3.2 Offset control

The quiescent output voltage must be as close as possible to its nominal value, so that less undistorted power would be available.

For this reason an input bias current compensation is implemented to reduce the voltage drop across the input resistors, which appears amplified at the outputs.

#### 3.3.3 Gain internally fixed to 26 dB

Advantages of this design choice are in terms of:

- components and space saving
- output noise, supply voltage rejection and distortion optimization.

#### 3.3.4 Silent turn on/off and muting/stand-by function

The stand-by can be easily activated by means of a CMOS level applied to pin 7 through a RC filter.

Under stand-by condition the device is turned off completely (supply current = 1  $\mu$ A typ.; output attenuation = 90 dB typ.). Every ON/OFF operation is virtually pop free.

Furthermore, at turn-on the device stays in muting condition for a time determined by the value assigned to the SVR capacitor ( $T = C_{svr} * 7,000$ ).

While in muting the device outputs becomes insensitive to any kinds of signal that may be present at the input terminals. In other words every transient coming from previous stages produces no unpleasant acoustic effect to the speakers. Another situation under which the device is totally muted is whenever the supply voltage drops lower than 7V. This is helpful to pop suppression during the turn-off by battery switch.

## 3.4 Built-in protection systems

### 3.4.1 Full protection of device and loudspeakers against AC/DC short circuits (to Gnd, to $V_S$ , across the speakers)

Reliable and safe operation in presence of all kinds of short circuit involving the outputs is assured by a built-in protection system that operates in the following way:

In case of overload, a SCR is activated as soon as the current flowing through the output transistors overcomes a preset threshold value depending on the chip temperature. The SCR causes an interruption of the supply current of the power transistor.

### 3.4.2 Load dump voltage surge

The TDA7374 has a circuit which enables it to withstand a voltage pulse train on pins 3 and 13, of the type shown in [Figure 20](#). If the supply voltage peaks to more than 50V, then an LC filter must be inserted between the supply and pins 3 and 13, in order to assure that the pulses at pins 3 and 13 will be held within the limits shown.

A suggested LC network is shown in [Figure 19](#). With this network, a train of pulses with amplitude up to 120 V and width of 2ms can be applied at point A. This type of protection is ON when the supply voltage (pulse or DC) exceeds 18 V. For this reason the maximum operating supply voltage is 18 V.

**Figure 19. A suggested LC network**

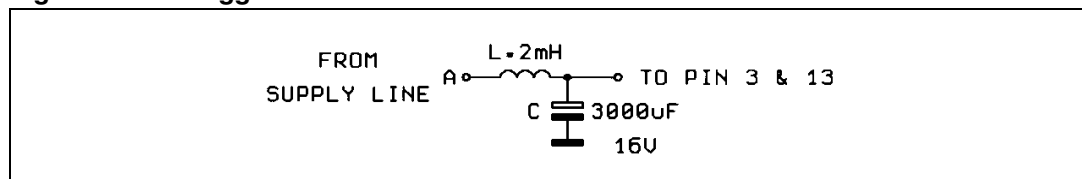

**Figure 20. Voltage pulse train on pins 3 and 13**

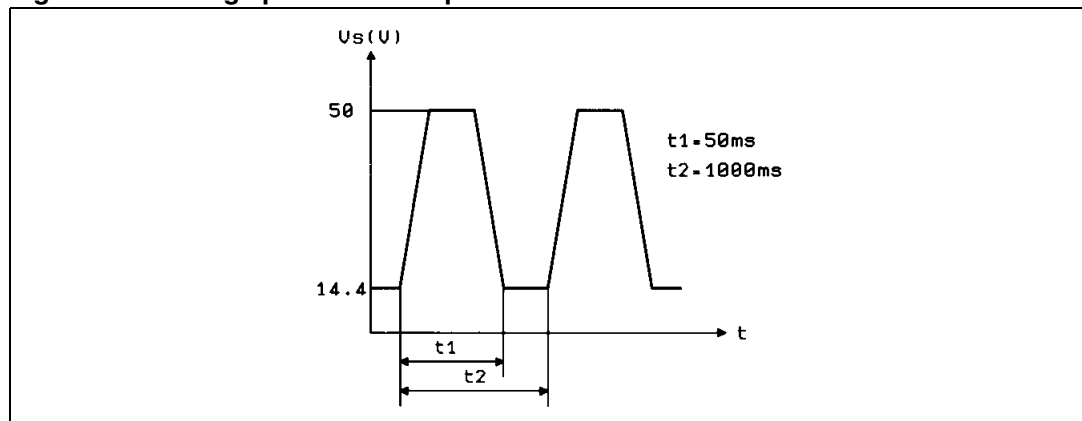

### 3.4.3 Polarity inversion

High current (up to 10 A) can be handled by the device with no damage for a longer period than the blow-out time of a quick 2 A fuse (normally connected in series with the supply). This feature is added to avoid destruction, if during fitting to the car, a mistake on the connection of the supply is made.

### 3.4.4 Open ground

When the radio is in the ON condition and the ground is accidentally opened, a standard audio amplifier will be damaged. On the TDA7374 protection diodes are included to avoid any damage.

### 3.4.5 Inductive load

A protection diode is provided to allow use of the TDA7374 with inductive loads.

### 3.4.6 DC voltage

The maximum operating DC voltage for the TDA7374 is 18 V. However the device can withstand a DC voltage up to 28 V with no damage. This could occur during winter if two batteries are series connected to crank the engine.

### 3.4.7 Thermal shut-down

The presence of a thermal limiting circuit offers the following advantages:

1. an overload on the output (even if it is permanent), or an excessive ambient temperature can be easily withstood.
2. the heatsink can have a smaller factor of safety compared with that of a conventional circuit. There is no device damage in case of excessive junction temperature: all happens is that  $P_o$  (and therefore  $P_{tot}$ ) and  $I_d$  are reduced.

The maximum allowable power dissipation depends upon the size of the external heatsink (i.e. its thermal resistance); [Figure 21](#) shows the dissipable power as a function of ambient temperature for different thermal resistance.

**Figure 21. Maximum allowable power dissipation vs. ambient temperature**

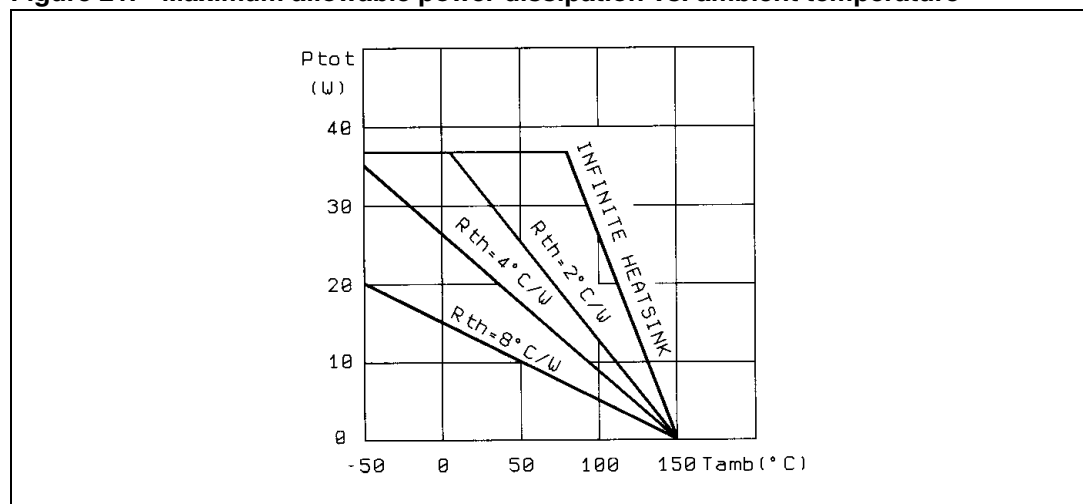

### 3.4.8 Loudspeaker protection

The TDA7374 guarantees safe operations even for the loudspeaker in case of accidental shortcircuit.

Whenever a single OUT to GND, OUT to  $V_S$  short circuit occurs both the outputs are switched OFF so limiting dangerous DC current flowing through the loudspeaker.

### 3.5 Clipping detector

Figure 23 shows an application using the TDA7374 in combination with the STM audioprocessor TDA7302. The output clipping is recognized by the microprocessor (in this application it is simulated by a PC). The detailed way to operate of the system is represented by the flow-chart of Figure 22.

The controller detects when the clipping is active (minimum detection width fixed by a  $C_{29} = 12 \text{ nF}$  external capacitor), and reduces the volume (or bass) by step of 2 dB (with a programmable waiting time), until no more clipping is detected. Then the controller waits for a programmable time before increasing the volume again by step of 2 dB until clipping is again detected or the panel selected volume is reached.

Practical advantages of this application is a better sound quality deriving from operation under no clipping conditions, which also means the availability of higher undistorted power.

Figure 22. Clipping detector control routine

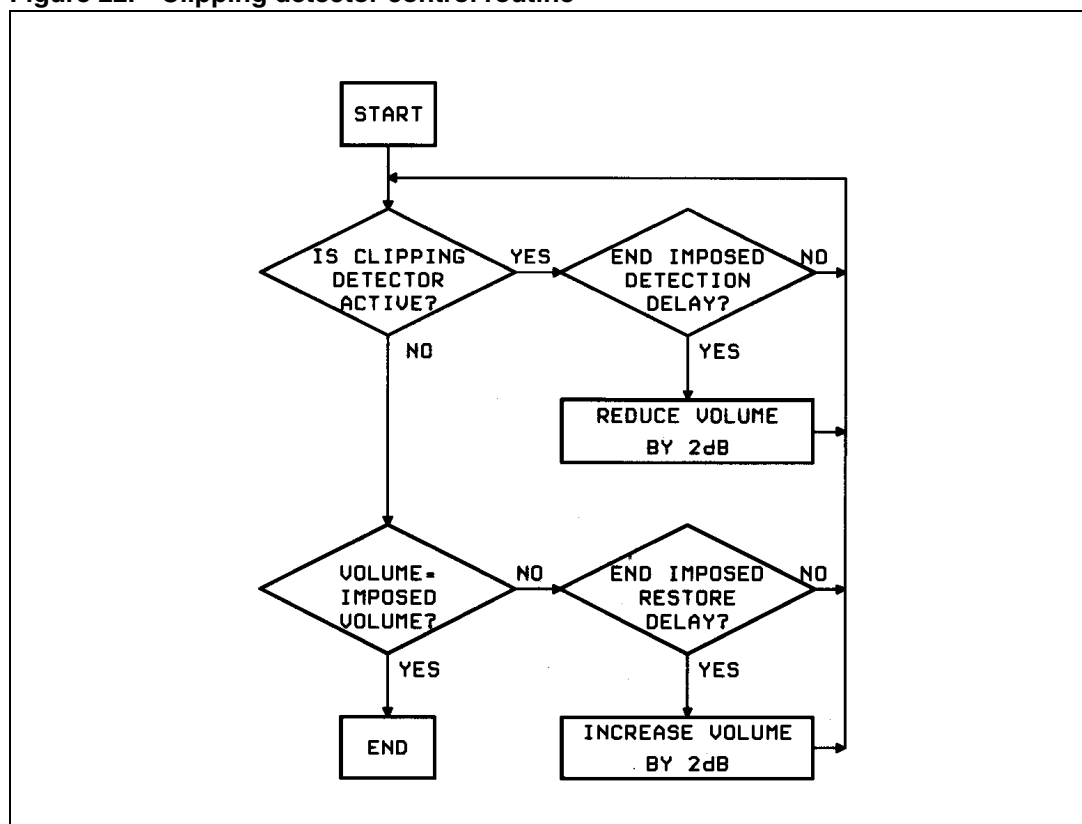

### 3.6 What is needed for a demonstration

- IBM compatible PC with parallel port
- STM audioprocessor application disk
- TDA7302 + TDA7374 board
- Connector from audioprocessor board to PC parallel port

### 3.6.1 General Information

In the application shown in *Figure 23* the TDA7302 audioprocessor works on PC IBM compatible.

Control is accomplished by serial bus (S-bus or I<sup>2</sup>C bus or SPI bus) sent to the test board through the PC parallel port.

The PC simulates the behaviour of the microprocessor in a real application (for example in a car radio) and the buffer is necessary only in this application for protecting the PC.

**Figure 23. Application with TDA7302 + TDA7374**

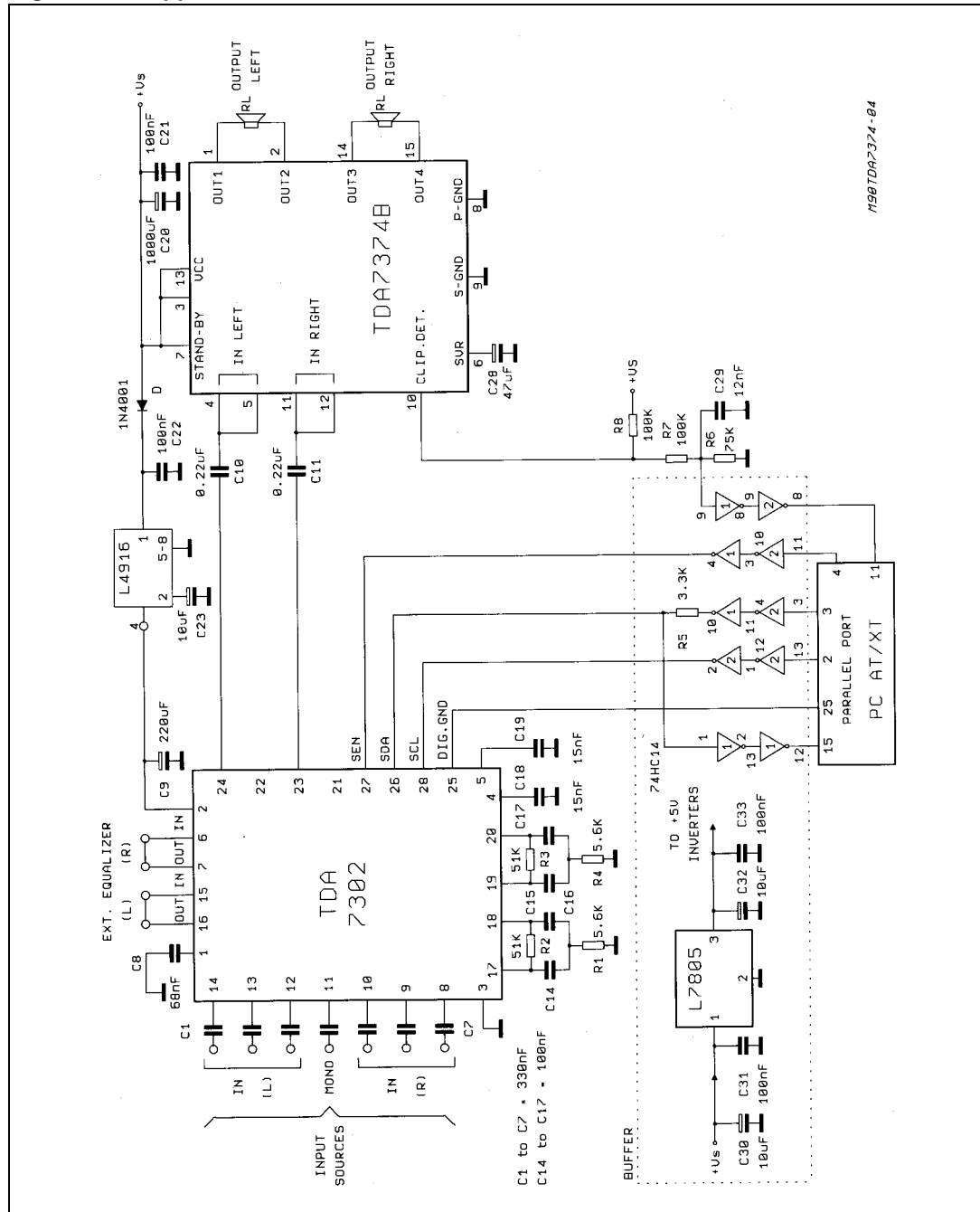



## 4 Package information

In order to meet environmental requirements, ST (also) offers these devices in ECOPACK® packages. ECOPACK® packages are lead-free. The category of second Level Interconnect is marked on the package and on the inner box label, in compliance with JEDEC Standard JESD97. The maximum ratings related to soldering conditions are also marked on the inner box label.

ECOPACK is an ST trademark. ECOPACK specifications are available at: [www.st.com](http://www.st.com).

**Figure 24. Multiwatt 15 mechanical data and package dimensions**

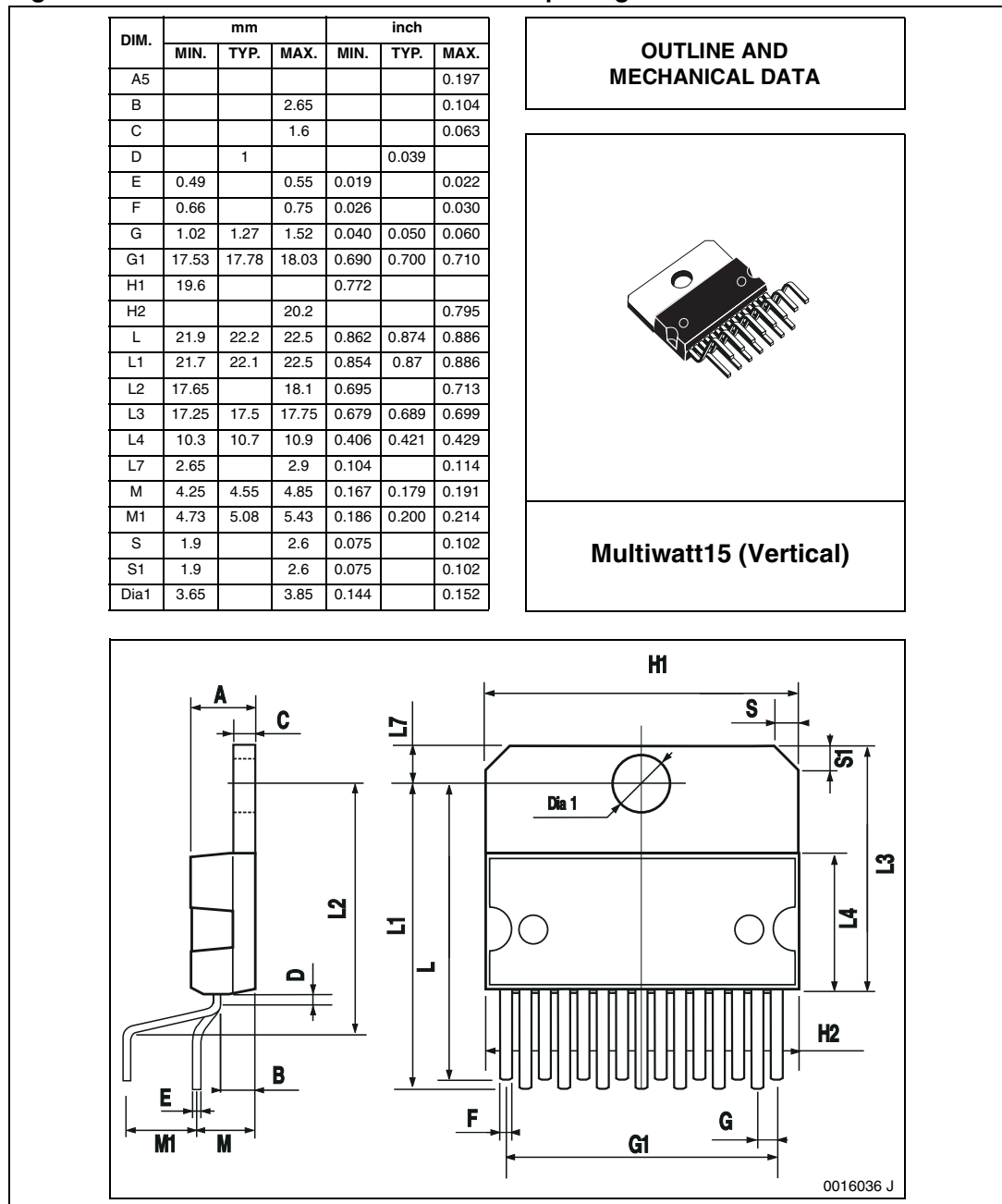

## 5 Revision history

**Table 5. Document revision history**

Date	Revision	Changes
12-Oct-1999	3	Initial release.
30-Jun-2008	4	Document reformatted. Added <a href="#">Table 1: Device summary</a> . Added ECOPACK description in <a href="#">Section 4: Package information</a> .

**Please Read Carefully:**

Information in this document is provided solely in connection with ST products. STMicroelectronics NV and its subsidiaries ("ST") reserve the right to make changes, corrections, modifications or improvements, to this document, and the products and services described herein at any time, without notice.

All ST products are sold pursuant to ST's terms and conditions of sale.

Purchasers are solely responsible for the choice, selection and use of the ST products and services described herein, and ST assumes no liability whatsoever relating to the choice, selection or use of the ST products and services described herein.

No license, express or implied, by estoppel or otherwise, to any intellectual property rights is granted under this document. If any part of this document refers to any third party products or services it shall not be deemed a license grant by ST for the use of such third party products or services, or any intellectual property contained therein or considered as a warranty covering the use in any manner whatsoever of such third party products or services or any intellectual property contained therein.

**UNLESS OTHERWISE SET FORTH IN ST'S TERMS AND CONDITIONS OF SALE ST DISCLAIMS ANY EXPRESS OR IMPLIED WARRANTY WITH RESPECT TO THE USE AND/OR SALE OF ST PRODUCTS INCLUDING WITHOUT LIMITATION IMPLIED WARRANTIES OF MERCHANTABILITY, FITNESS FOR A PARTICULAR PURPOSE (AND THEIR EQUIVALENTS UNDER THE LAWS OF ANY JURISDICTION), OR INFRINGEMENT OF ANY PATENT, COPYRIGHT OR OTHER INTELLECTUAL PROPERTY RIGHT.**

**UNLESS EXPRESSLY APPROVED IN WRITING BY AN AUTHORIZED ST REPRESENTATIVE, ST PRODUCTS ARE NOT RECOMMENDED, AUTHORIZED OR WARRANTED FOR USE IN MILITARY, AIR CRAFT, SPACE, LIFE SAVING, OR LIFE SUSTAINING APPLICATIONS, NOR IN PRODUCTS OR SYSTEMS WHERE FAILURE OR MALFUNCTION MAY RESULT IN PERSONAL INJURY, DEATH, OR SEVERE PROPERTY OR ENVIRONMENTAL DAMAGE. ST PRODUCTS WHICH ARE NOT SPECIFIED AS "AUTOMOTIVE GRADE" MAY ONLY BE USED IN AUTOMOTIVE APPLICATIONS AT USER'S OWN RISK.**

Resale of ST products with provisions different from the statements and/or technical features set forth in this document shall immediately void any warranty granted by ST for the ST product or service described herein and shall not create or extend in any manner whatsoever, any liability of ST.

ST and the ST logo are trademarks or registered trademarks of ST in various countries.

Information in this document supersedes and replaces all information previously supplied.

The ST logo is a registered trademark of STMicroelectronics. All other names are the property of their respective owners.

© 2008 STMicroelectronics - All rights reserved

STMicroelectronics group of companies

Australia - Belgium - Brazil - Canada - China - Czech Republic - Finland - France - Germany - Hong Kong - India - Israel - Italy - Japan - Malaysia - Malta - Morocco - Singapore - Spain - Sweden - Switzerland - United Kingdom - United States of America

[www.st.com](http://www.st.com)

