

### Features

- **600mA Output Current**
- **2.5V to 5.5V Input Voltage Range**
- **1.5MHz Constant Frequency Operation**
- **Low Dropout Operation at 100% Duty Cycle**
- **Synchronous Topology:**  
**No Schottky Diode Required**
- **0.6V Low Reference Voltage**
- **Shutdown Mode Supply Current Under 1mA**
- **Current Mode Operation for Excellent Line and Load Transient Response**
- **Over-Temperature Protection**
- **Over Current Protection**
- **SOT-23-5 Package**
- **Lead Free and Green Devices Available (RoHS Compliant)**

### Applications

- **Cellular Telephones**
- **Personal Information Appliances**
- **Wireless and DSL Modems**
- **MP3 Players**
- **Digital Still Cameras**
- **Portable Instruments**

### General Description

The APW7101 is a high efficiency monolithic synchronous buck regulator. APW7101 operates with a constant 1.5MHz switching frequency and using the inductor current as a controlled quantity in the current mode architecture. The device is available in an adjustable version and fixed output voltages of 1.5V and 1.8V. The 2.5V to 5.5V input voltage range makes the APW7101 ideally suited for single Li-Ion battery powered applications. 100% duty cycle provides low dropout operation, extending battery life in portable electrical devices. The internally fixed 1.5MHz operating frequency allows the use of small surface mount inductors and capacitors. The synchronous switches included inside increase the efficiency and eliminate the need for an external Schottky diode. Low output voltages are easily supported with the 0.6V feedback reference voltage. The APW7101 is available in a low profile SOT package for saving the printed circuit board area.

### Pin Configuration

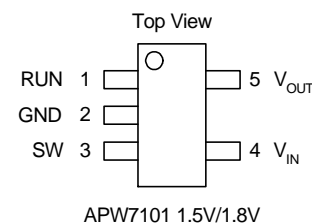
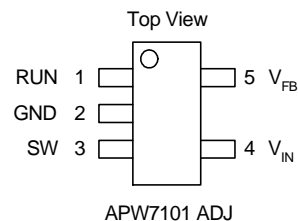

ANPEC reserves the right to make changes to improve reliability or manufacturability without notice, and advise customers to obtain the latest version of relevant information to verify before placing orders.

## Ordering and Marking Information

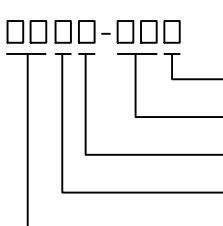
<p>APW7101 - □□□□-□□□□</p>  <p>Assembly Material Handling Code Temperature Range Package Code Voltage Code</p>	<p>Package Code B : SOT-23-5 Temperature Range I : -40 to 85 °C Handling Code TR : Tape &amp; Reel Voltage Code 15: 1.5V 18: 1.8V Blank : Adjustable Version Assembly Material L : Lead Free Device G : Halogen and Lead Free Device</p>
<p>APW7101-15 : <span style="border: 1px solid black; padding: 2px;">019X</span> X - Date Code</p>	<p>APW7101-18 : <span style="border: 1px solid black; padding: 2px;">01CX</span> X - Date Code</p>
<p>APW7101 : <span style="border: 1px solid black; padding: 2px;">W01X</span> X - Date Code</p>	

Note : ANPEC lead-free products contain molding compounds/die attach materials and 100% matte tin plate termination finish; which are fully compliant with RoHS. ANPEC lead-free products meet or exceed the lead-free requirements of IPC/JEDEC J-STD-020C for MSL classification at lead-free peak reflow temperature. ANPEC defines "Green" to mean lead-free (RoHS compliant) and halogen free (Br or Cl does not exceed 900ppm by weight in homogeneous material and total of Br and Cl does not exceed 1500ppm by weight).

## Absolute Maximum Ratings

Symbol	Parameter	Value	Unit
V <sub>CC</sub>	Input Supply Voltage (VCC to GND)	-0.3V to 6V	V
V <sub>RUN</sub>	RUN Pin Voltage	-0.3V to (VCC+0.3V)	V
V <sub>FB</sub>	Feedback Voltage	-0.3V to (VCC+0.3V)	V
V <sub>SW</sub>	Switching Voltage	-0.3V to (VCC+0.3V)	V
I <sub>SW_PEAK</sub>	Peak SW Current	1.3	A
P <sub>D</sub>	Average Power Dissipation	0.5	W
T <sub>J</sub>	Junction Temperature, T <sub>A</sub> < 50°	150	°C
T <sub>STG</sub>	Storage Temperature	-65 ~ 150	°C
T <sub>SDR</sub>	Maximum Lead Soldering Temperature, 10 Seconds	260	°C

## Thermal Characteristics

Symbol	Parameter	Typical Value	Unit
θ <sub>JA</sub>	Junction to Ambient Thermal Resistance in Free Air	250	°C/W

## Electrical Characteristics

The \* denotes the specifications that apply over  $T_A = -40^{\circ}\text{C} \sim 85^{\circ}\text{C}$ , otherwise specifications are at  $T_A = 25^{\circ}\text{C}$ .

Symbol	Parameter	Test conditions	APW7101			Unit
			Min.	Typ.	Max.	
$I_{VFB}$	Feedback Current	*	-30	-	30	nA
$V_{IN}$	Input Voltage Range	*Note	2.5	-	5.5	V
$V_{FB}$	Regulated Feedback Voltage	$-40^{\circ}\text{C} \leq T_A \leq 85^{\circ}\text{C}$	0.585	0.6	0.615	V
$\Delta V_{FB}$	Reference Voltage Line Regulation	$V_{IN} = 2.5\text{V to } 5.5\text{V}$	-	0.04	0.4	%/V
$V_{OUT}$	Regulated Output Voltage	APW7101-1.5, $I_{OUT} = 100\text{mA}$	1.455	1.500	1.545	V
		APW7101-1.8, $I_{OUT} = 100\text{mA}$	1.746	1.800	1.854	V
$\Delta V_{OUT}$	Output Voltage Line Regulation	$V_{IN} = 2.5\text{V to } 5.5\text{V}$	-	0.04	0.4	%/V
$I_{PK}$	Peak Inductor Current	$V_{IN} = 3\text{V}$ , $V_{FB} = 0.5\text{V}$ or $V_{OUT} = 90\%$ Duty < 35%	0.75	1	1.25	A
$V_{LOADR}$	Output Voltage Load Regulation		-	0.5		%
$I_Q$	Quiescent Current	Duty Cycle = 0; $V_{FB} = 1.5\text{V}$	-	300	400	$\mu\text{A}$
$I_{Q\_SD}$	Quiescent Current in Shutdown		-	0.1	1	$\mu\text{A}$
$f_{OSC}$	Oscillator Frequency	$V_{FB} = 0.6\text{V}$ or $V_{OUT} = 100\%$	1.2	1.5	1.8	MHz
$f_{OSC\_FFB}$	Frequency Foldback	$V_{FB} = 0\text{V}$ or $V_{OUT} = 0\text{V}$	-	300	-	kHz
$R_{DSON\_P}$	On Resistance of P MOSFET	$I_{SW} = 100\text{mA}$	-	0.4	0.5	$\Omega$
$R_{DSON\_N}$	On Resistance of N MOSFET	$I_{SW} = -100\text{mA}$	-	0.35	0.45	$\Omega$
$I_{LSW}$	SW Leakage Current	$V_{RUN} = 0\text{V}$ , $V_{SW} = 0\text{V}$ or $5\text{V}$ , $V_{IN} = 5\text{V}$	-	$\pm 0.01$	$\pm 1$	$\mu\text{A}$
$V_{RUN}$	RUN Threshold	*	0.3	1	1.5	V
$I_{RUN}$	RUN Leakage Current	*	-	$\pm 0.01$	$\pm 1$	$\mu\text{A}$

Note: The Maximum output current didn't reach 600mA when the supply voltage below 2.7V.

## Pin Description

No.	PIN	FUNCTION
1	RUN	Control input pin. Forcing this pin above 1.5V enables APW7101. Forcing this pin below 0.3V shuts down APW7101. In shutdown situation, all functions are disabled to decrease the supply current below 1 $\mu\text{A}$ . There is no pull high or pull low ability inside.
2	GND	Ground pin.
3	SW	Connected this pin to the inductor of the power stage. This pin connected to the drain terminals of the main and synchronous power MOSFET switches inside.
4	$V_{IN}$	Must be closely decoupled to GND with 4.7 $\mu\text{F}$ or greater ceramic capacitor.
5	$V_{FB}/V_{OUT}$	In the adjustable version, feedback function is available. The feedback voltage decided by an external resistive divider across the output. In the fixed version, an internal resistive divider divides the output voltage down for comparison to the internal reference voltage.

### Block Diagram

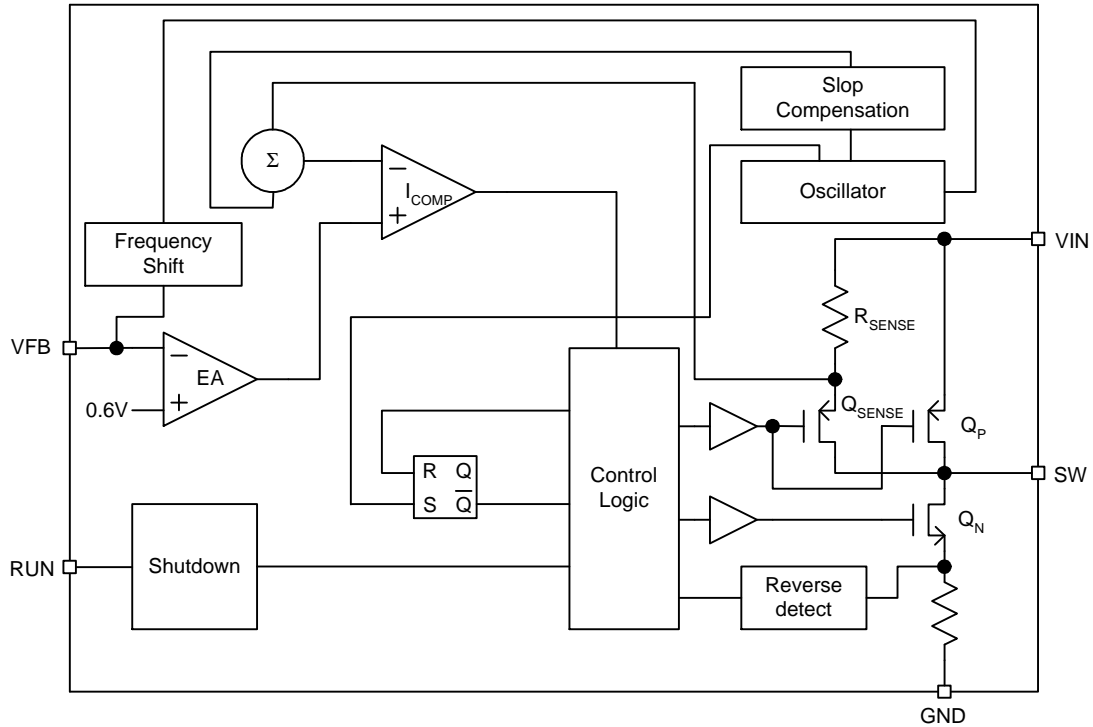

### Application Circuit

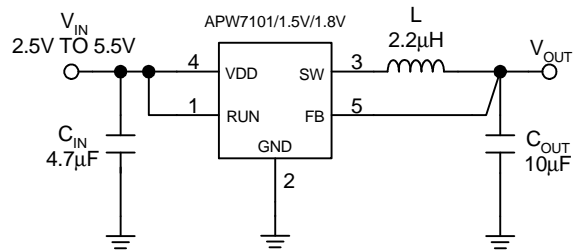
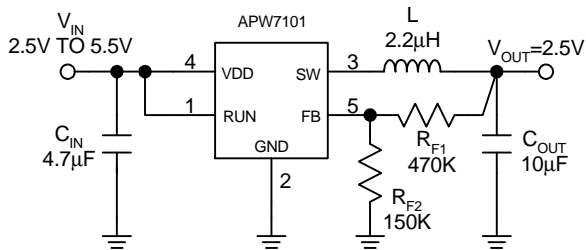

- C<sub>IN</sub>: Murata GRM31CR61C475K
- C<sub>OUT</sub>: Murata GRM31CR61A106K
- L: Gotrend GTSD53

## Typical Operating Characteristics

Reference Voltage

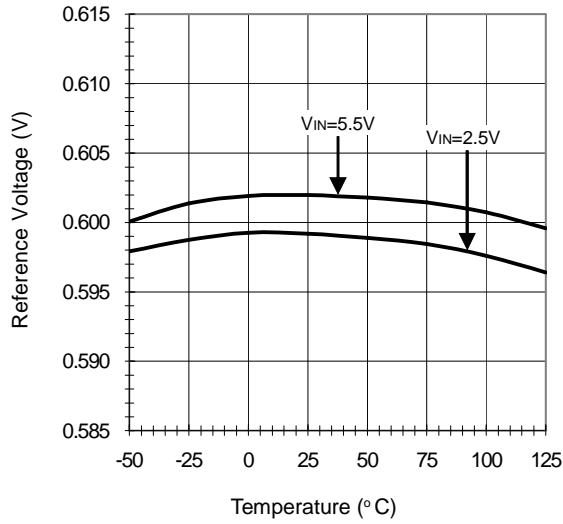

Oscillator Frequency

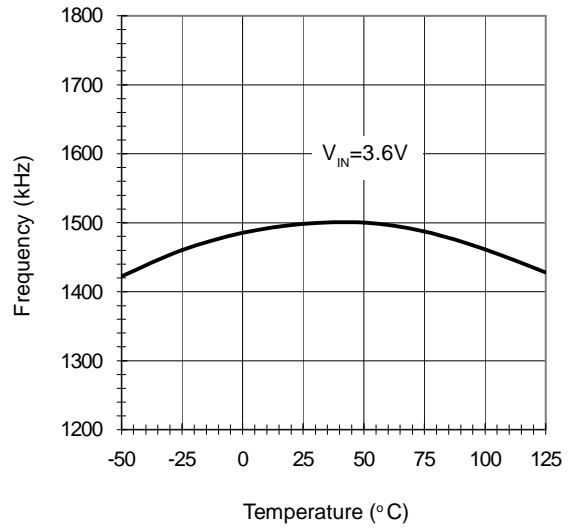

Oscillator Frequency vs Supply Voltage

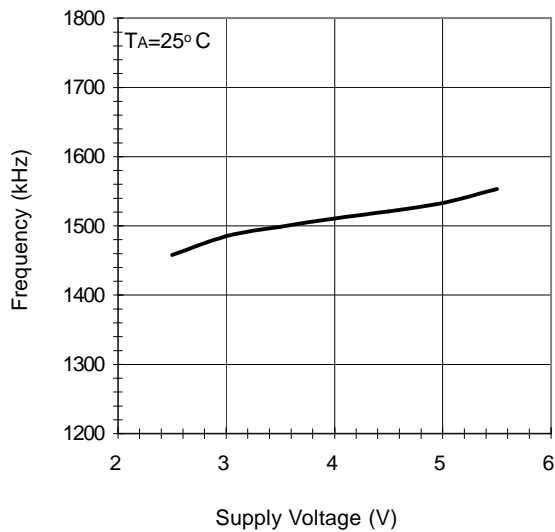

RDS(ON) vs Temperature

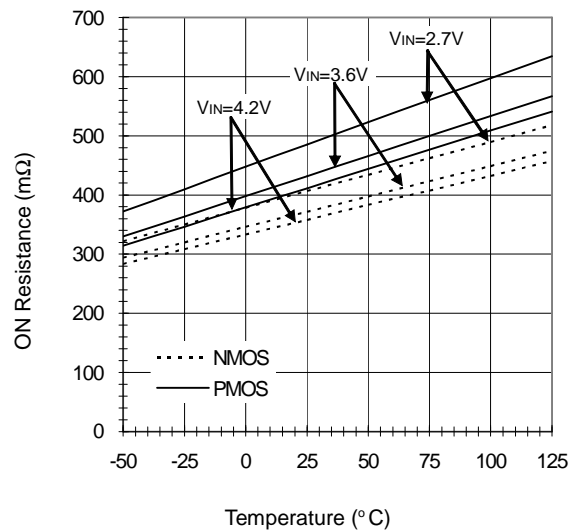

Typical Operating Characteristics (Cont.)

RDS(ON) vs Input Voltage

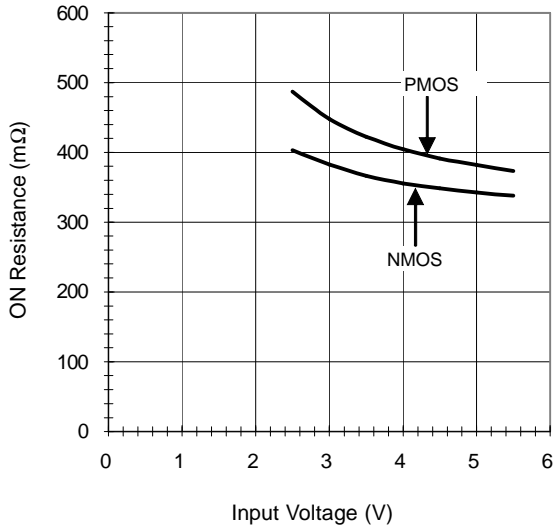

Efficiency vs Output Current

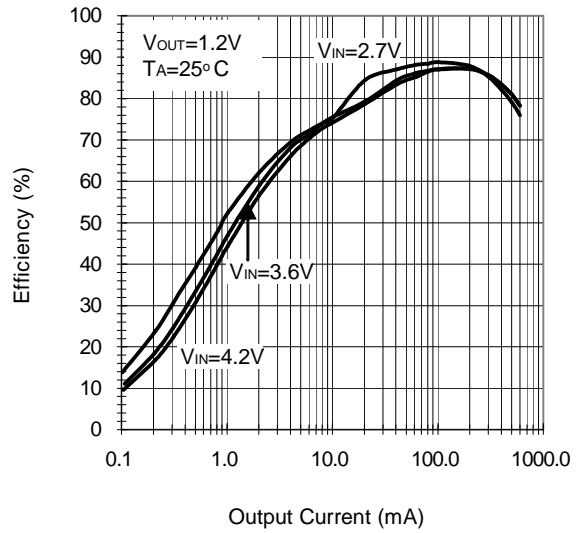

Efficiency vs Output Current

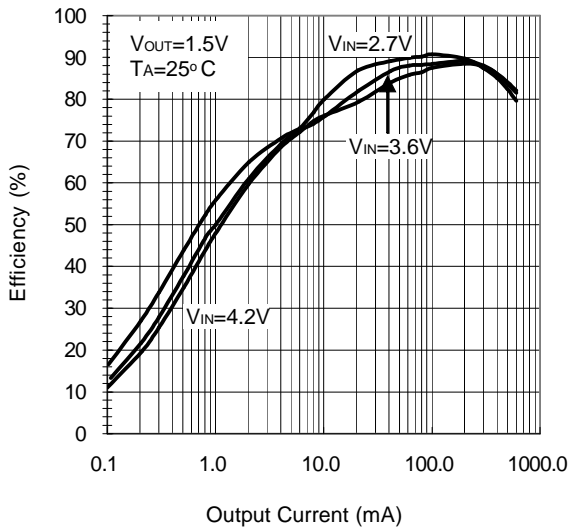

Efficiency vs Output Current

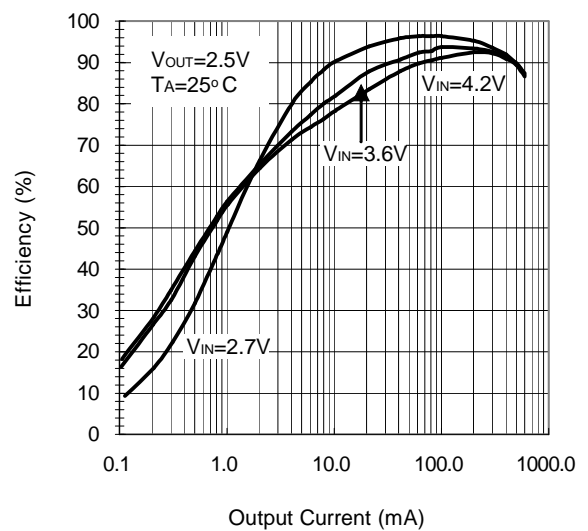

## Typical Operating Characteristics (Cont.)

Efficiency vs Output Current

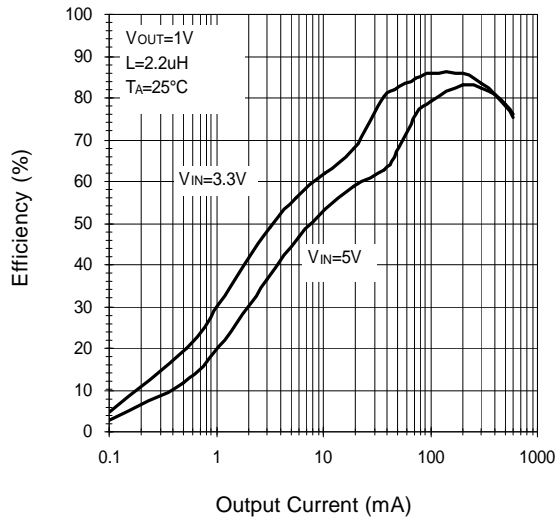

Output Voltage vs Output Current

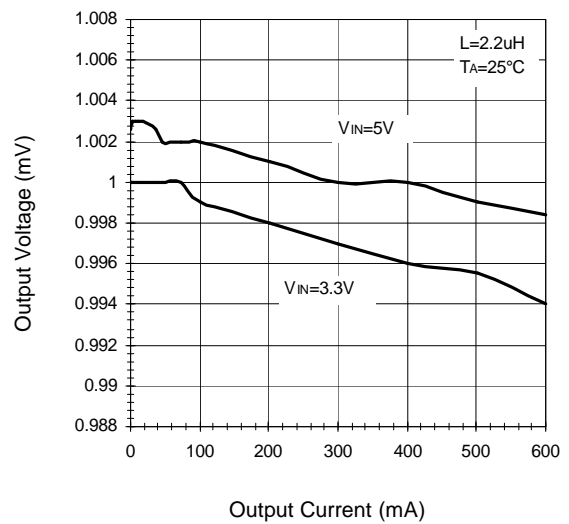

Efficiency vs Input Voltage

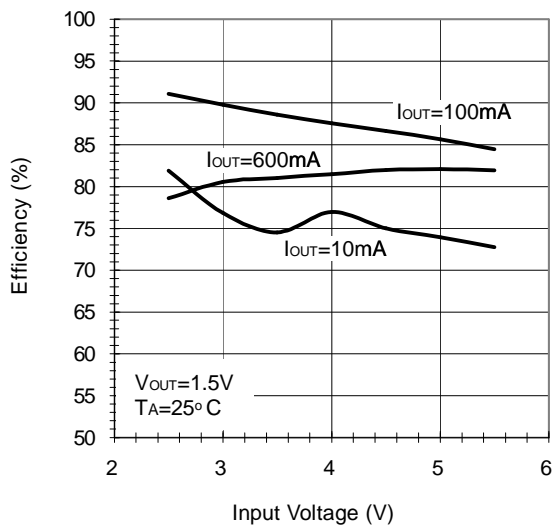

Efficiency vs Input Voltage

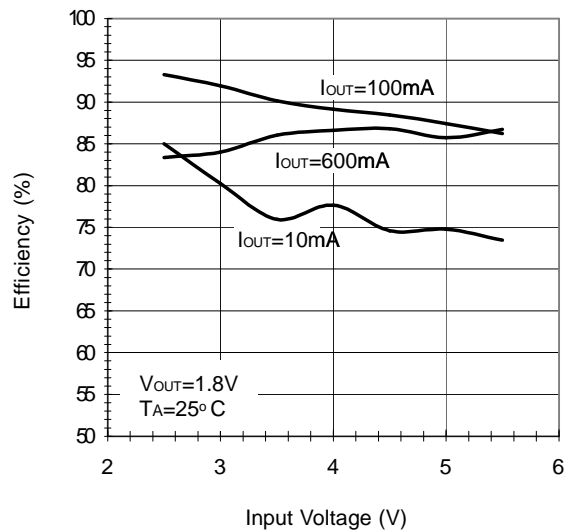

Typical Operating Characteristics (Cont.)

Efficiency vs Input Voltage

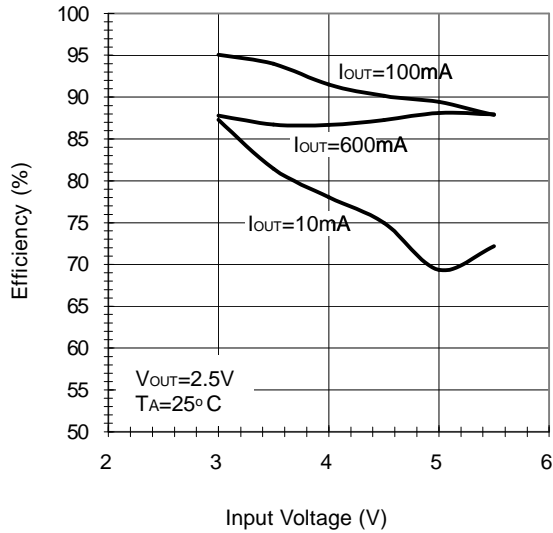

Dynamic Supply Current vs Supply Voltage

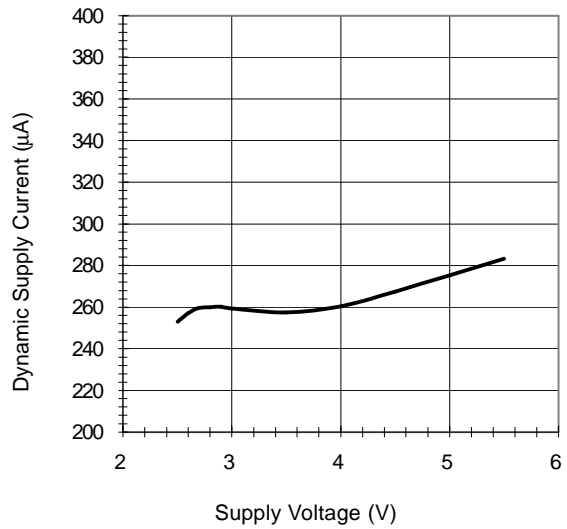

P-FET Leakage vs Temperature

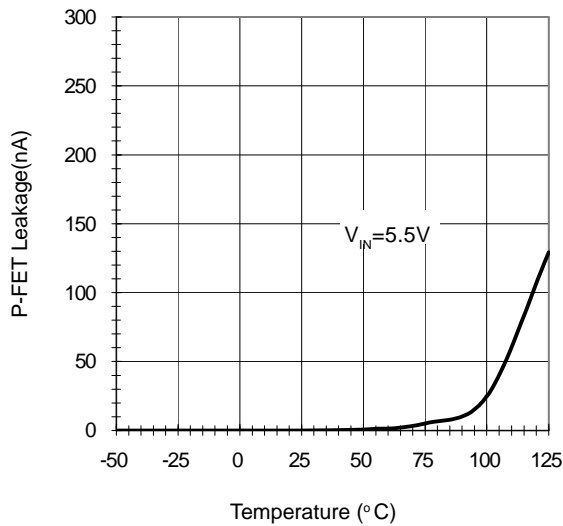

N-FET Leakage vs Temperature

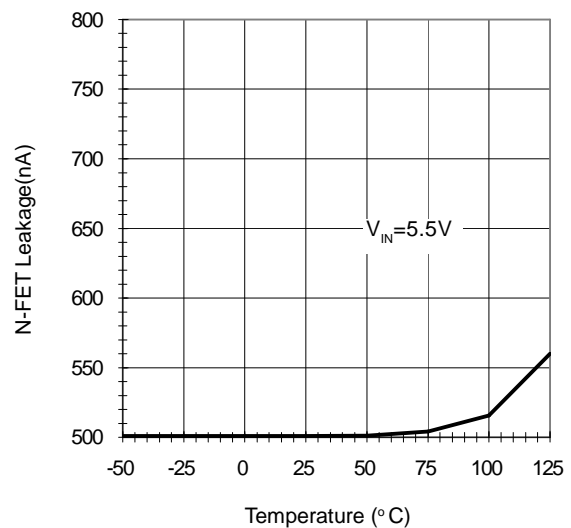



## Function Description

### Main Control Loop

The APW7101 uses a constant frequency, current mode step-down architecture. Both the main and synchronous switches are internal to reduce the external components. During normal operation, the internal PMOSFET is turned on, but is turned off when the inductor current at the input of  $I_{COMP}$  to reset the RS latch. The load current increases, it causes a slight decrease in the feedback voltage, which in turn, causes the EA's output voltage to increase until the average inductor current matches the new load current. While the internal power PMOSFET is off, the internal power NMOSFET is turned on until the inductor current starts to reverse, as indicated by the current reversal comparator  $I_{RCMP}$ , or the beginning of next cycle. When the NMOSFET is turned off by  $I_{RCMP}$ , it operates in the discontinuous conduction mode.

### Pulse Skipping Mode Operation

At light load with a relative small inductance, the inductor current may reach zero. The internal power NMOSFET is turned off by the current reversal comparator,  $I_{RCMP}$ , and the switching voltage will ring. This is discontinuous mode operation, and is normal behavior for the switching regulator. At very light load, the APW7101 will automatically skip some pulses in the pulse skipping mode to maintain the output regulation. The skipping process modulates smoothly depend on the load.

### Short Circuit Protection

In the short circuit situation, the output voltage is almost zero volts. Output current is limited by the  $I_{COMP}$  to prevent the damage of electrical circuit. In the normal operation, the two straight line of the inductor current ripple have the same height, it means the volts-seconds product is the same. When the short circuit operation occurs, the output voltage down to zero leads to the voltage across the inductor maximum in the on period and the voltage across the inductor minimum in the off period. In order to maintain the volts-seconds balance, the off-time must be extended to prevent the inductor current run away. Frequency decay will extend the switching period to provide more times to the off-period, then the inductor

current has to restrict to protect the electrical circuit in the short situation.

### Dropout Operation

As the input supply voltage decreases to a value approaching the output voltage, the duty cycle increases toward the maximum on time. Further reduction of the supply voltage forces the main switch to remain on for more than one cycle until it reaches 100% duty cycle. The output voltage will then be determined by the input voltage minus the voltage drop across the PMOSFET and the inductor.

An important detail to remember is that on resistance of PMOSFET switch will increase at low input supply voltage. Therefore, the user should calculate the power dissipation when the APW7101 is used at 100% duty cycle with low input voltage.

### Slope Compensation

Slope compensation provides stability in constant frequency current mode architecture by preventing sub-harmonic oscillations at high duty cycle. It is accomplished internally by adding a compensating ramp to the inductor current signal at duty cycle in excess of 40%. Normally, this results in a reduction of maximum inductor peak current for duty cycles greater than 40%. In the APW7101, the reduction of inductor peak current recovered by a special skill at high duty ratio. This allows the maximum inductor peak current maintain a constant level through all duty ratio.

## Application Information

### Inductor Selection

Due to the high switching frequency as 1.5MHz, the inductor value of the application field of APW7101 is usually from 1μH to 4.7μH. The criterion to select a suitable inductor is dependent on the worst current ripple throughout the inductor. The worst current ripple defines as 40% of the fully load capability. In the APW7101 applications, the worst value of current ripple is 240mA, the 40% of 600mA. Evaluate L by equation (1):

$$L = \frac{(V_{IN} - V_{OUT}) \cdot V_{OUT}}{V_{IN}} \cdot \frac{1}{\Delta I_L \cdot f_s} \dots\dots(1)$$

where  $f_s$  is the switching frequency of APW7101 and  $\Delta I_L$  is the value of the worst current ripple, it can be any value of current ripple that smaller than the worst value you can accept. In order to perform high efficiency, selecting a low DC resistance inductor is a helpful way. Another important parameter is the DC current rating of the inductor. The minimum value of DC current rating equals the full load value of 600mA, plus the half of the worst current ripple, 120mA. Choose inductors with suitable DC current rating to ensure the inductors don't operate in the saturation.

### Input Capacitor Selection

The input capacitor must be able to support the maximum input operating voltage and maximum RMS input current. The Buck converter absorbs current from input in pulses.

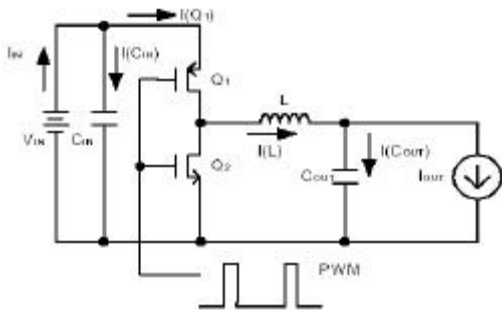

Figure-1

Figure-1 shows a schematic of a Buck structure. The waveforms is shown as Figure-2.

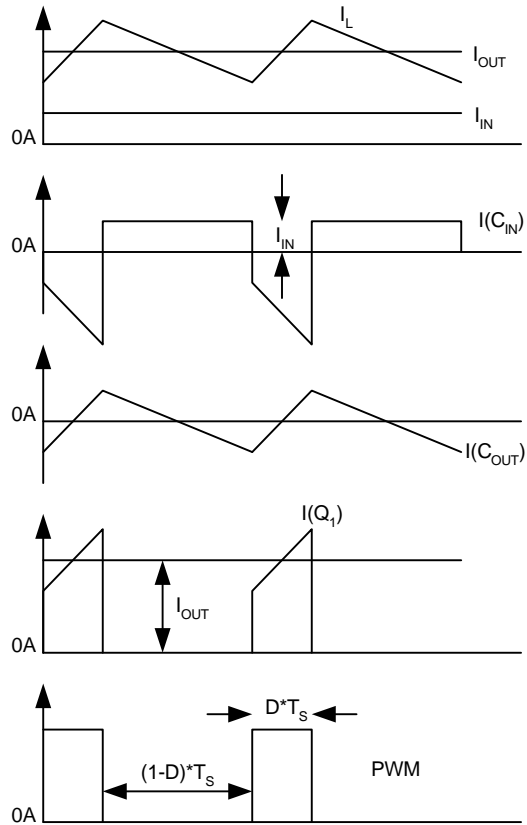

Figure-2

Observe the waveform of  $I(C_{IN})$ , the RMS value of  $I(C_{IN})$  is

$$I(C_{IN}) = \sqrt{[(I_{OUT} - I_{IN})^2 \cdot \sqrt{D}]^2 + (I_{IN} \cdot \sqrt{1-D})^2} \dots\dots(2)$$

Replace D and  $I_{IN}$  by following relation:

$$D = \frac{V_{OUT}}{V_{IN}} \dots\dots(3)$$

$$I_{IN} = D \cdot I_{OUT} \dots\dots(4)$$

The RMS value of input capacitor current equal:

$$I(C_{IN}) = I_{OUT} \cdot \sqrt{D(1-D)} \dots\dots(5)$$

When  $D=0.5$  the RMS current of input capacitor will be maximum value. Use this value to choose the input capacitor with suitable current rating.

## Application Information (Cont.)

### Output Capacitor Selection

The output voltage ripple is a significant parameter to estimate the performance of a converter. There are two discrete components that affect the output voltage ripple bigger or smaller. It is recommended to use the criterion has mentioned above to choose a suitable inductor. Then based on this known inductor current ripple condition, the value and properties of output capacitor will affect the output voltage ripple better or worse. The output voltage ripple consists of two portions, one is the product of ESR and inductor current ripple, the other portion is the function of the inductor current ripple and the output capacitance. Figure-3 shows the waveforms to explain the part decided by the output capacitance.

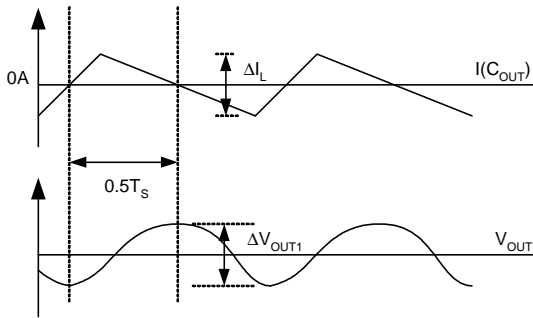

Figure-3

Evaluate the  $\Delta V_{OUT1}$  by the ideal of energy equalization. According to the definition of Q,

$$Q = \frac{1}{2} \left( \frac{1}{2} \Delta I_L \cdot \frac{1}{2} T_s \right) = C_{OUT} \cdot \Delta V_{OUT1} \quad \dots\dots (6)$$

where  $T_s$  is the inverse of switching frequency and the  $\Delta I_L$  is the inductor current ripple. Move the  $C_{OUT}$  to the left side to estimate the value of  $\Delta V_{OUT1}$  as equation (7).

$$\Delta V_{OUT1} = \frac{\Delta I_L \cdot T_s}{8 \cdot C_{OUT}} \quad \dots\dots (7)$$

As mentioned above, one part of output voltage ripple is the product of the inductor current ripple and ESR of output capacitor. The equation (8) explains the output voltage ripple estimation.

$$\Delta V_{OUT} = \Delta I_L \cdot \left( ESR + \frac{T_s}{8 \cdot C_{OUT}} \right) \quad \dots\dots (8)$$

### Thermal Consideration

APW7101 is a high efficiency switching converter, it means less power loss transferred into heat. Due to the on resistance difference between internal power PMOSFET and NMOSFET, the power dissipation in the high converting ratio is greater than low converting ratio. The worst case is in the dropout operation, the mainly conduction loss dissipate on the internal power PMOSFET. The power dissipation nearly defined as:

$$P_D = (I_{OUT})^2 [R_{DS\_ONP} \cdot D + R_{DS\_ONN} \cdot (1-D)] \quad \dots\dots (9)$$

APW7101 has internal over temperature protection. When the junction temperature reaches 150 centigrade, APW7101 will turn off both internal power PMOSFET and NMOSFET. The estimation of the junction temperature,  $T_J$ , defined as:

$$T_J = P_D \cdot \theta_{JA} \quad \dots\dots (10)$$

where the  $\theta_{JA}$  is the thermal resistance of the package utilized by APW7101.

### Output Voltage Setting

APW7101 has the adjustable version for output voltage setting by the users. A suggestion of maximum value of  $R_{F2}$  is 200kΩ to keep the minimum current that provides enough noise rejection ability through the resistor divider. The output voltage programmed by the equation:

$$V_{OUT} = 0.6 \cdot \left( 1 + \frac{R_{F1}}{R_{F2}} \right) \quad \dots\dots (11)$$

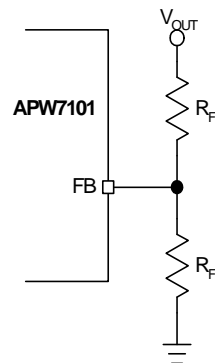

Figure-4

## Application Description (Cont.)

### PCB Layout Consideration

APW7101 is a high efficiency DC-DC converter which is a noise source in the electrical circuit by its switching operating. Some PCB layout considerations suppress the effect of switching operating by APW7101 itself to improve the better regulation.

- <1> Keep the power trace wide and short as possible. The power trace shows in the Figure-6 as thick solid lines.
- <2> Put the  $C_{IN}$  to  $V_{IN}$  close and  $C_{OUT}$  near the inductor as possible.
- <3> Keep the ground terminal of  $C_{IN}$  and  $C_{OUT}$  as close as possible to minimize the AC current loop.
- <4> Put the voltage divider consist of  $R_{F1}$  and  $R_{F2}$  closely to FB, the connection path between  $R_{F1}$  and  $V_{OUT}$  must far away the SW to prevent the switch noise coupling into FB by crosstalk. If necessary, the connection path between  $R_{F1}$  and  $V_{OUT}$  must near to SW, put a ground trace between the feedback trace and SW to prevent the coupling.

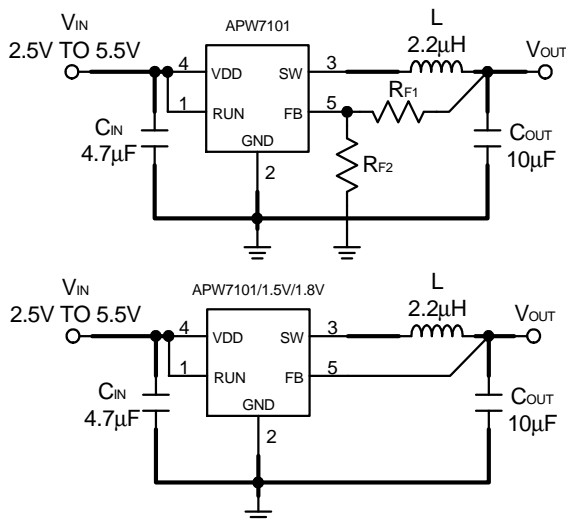

Figure-5

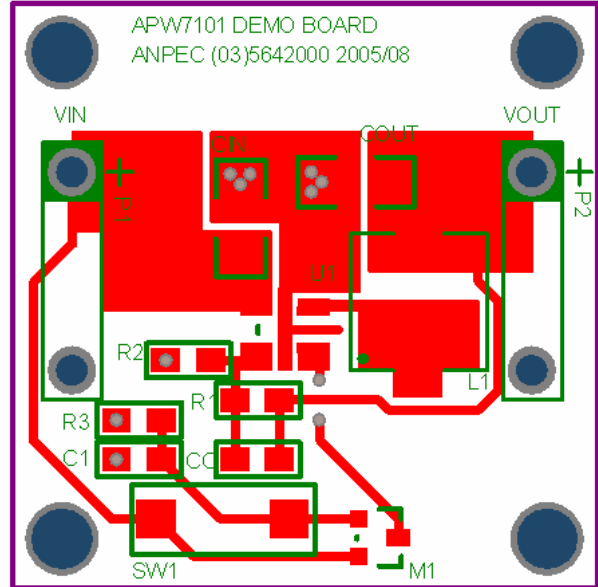

Figure-6  
Suggested layout Top Side

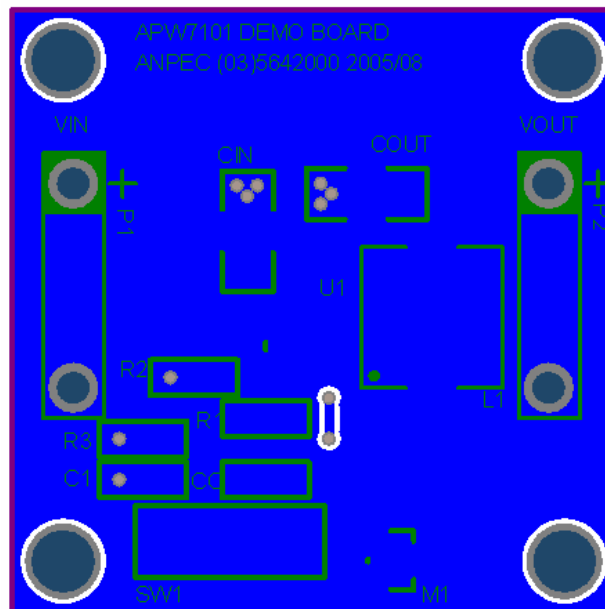
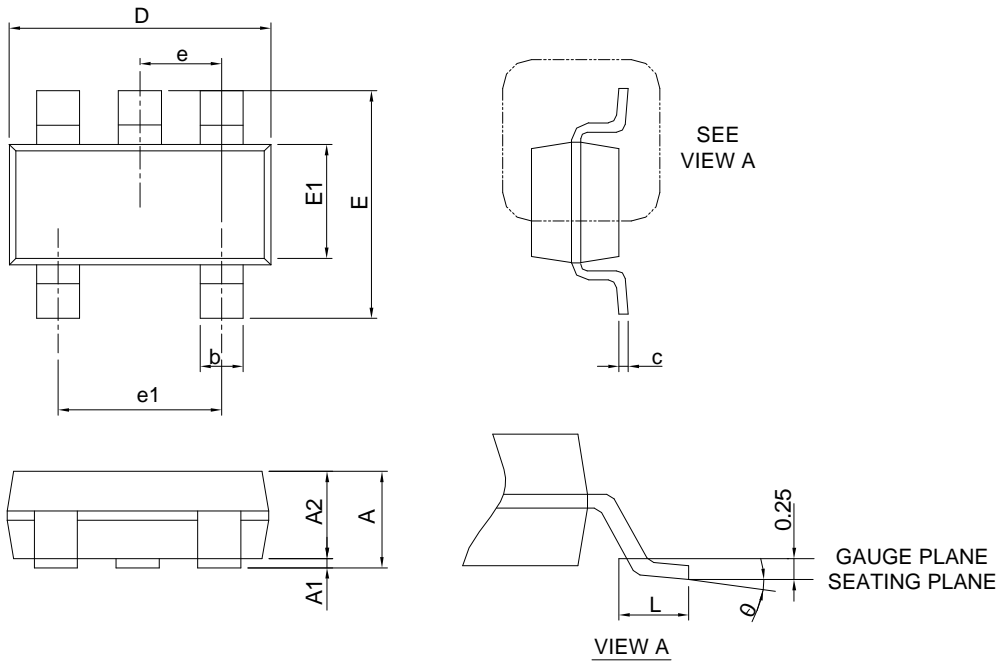

Figure-7  
Suggested layout Bottom Side

## Package Information

SOT-23-5



Symbol	SOT-23-5			
	MILLIMETERS		INCHES	
	MIN.	MAX.	MIN.	MAX.
A		1.45		0.057
A1	0.00	0.15	0.000	0.006
A2	0.90	1.30	0.035	0.051
b	0.30	0.50	0.012	0.020
c	0.08	0.22	0.003	0.009
D	2.70	3.10	0.106	0.122
E	2.60	3.00	0.102	0.118
E1	1.40	1.80	0.055	0.071
e	0.95 BSC		0.037 BSC	
e1	1.90 BSC		0.075 BSC	
L	0.30	0.60	0.012	0.024
θ	0°	8°	0°	8°

Note : 1. Follow JEDEC TO-178 AA.  
 2. Dimension D and E1 do not include mold flash, protrusions or gate burrs. Mold flash, protrusion or gate burrs shall not exceed 10 mil per side.

### Carrier Tape & Reel Dimensions

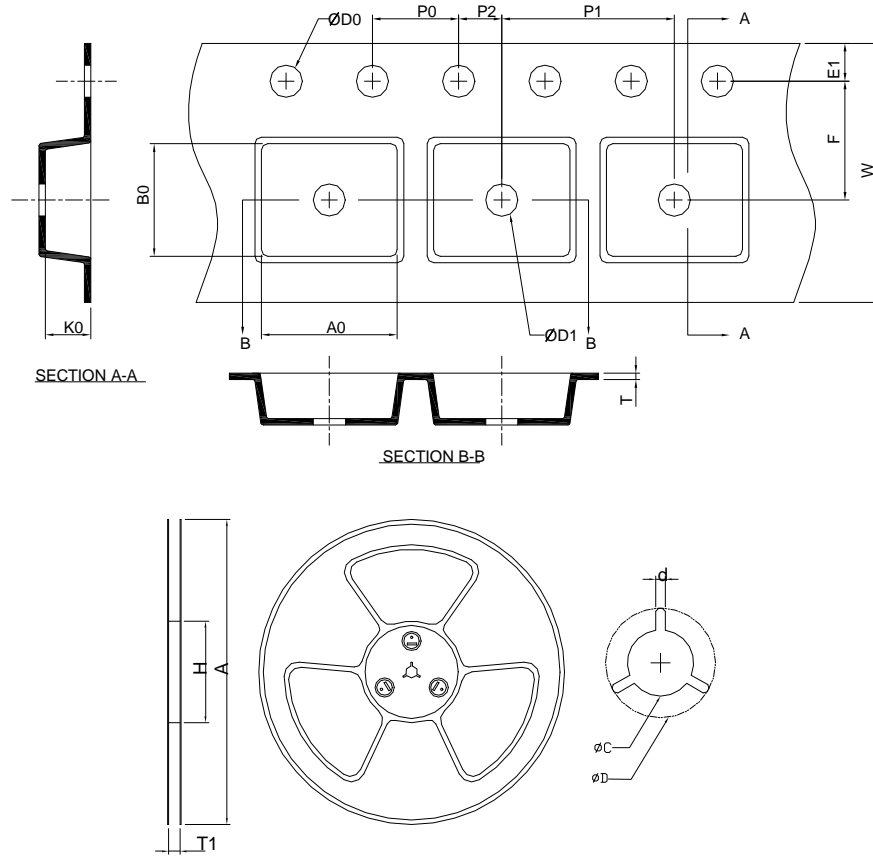

Application	A	H	T1	C	d	D	W	E1	F
SOT-23-5	178.0 ±0.00	50 MIN.	8.4+2.00 -0.00	13.0+0.50 -0.20	1.5 MIN.	20.2 MIN.	8.0 ±0.30	1.75 ±0.10	3.5 ±0.05
	P0	P1	P2	D0	D1	T	A0	B0	K0
	4.0 ±0.10	4.0 ±0.10	2.0 ±0.05	1.5+0.10 -0.00	1.0 MIN.	0.6+0.00 -0.40	3.20 ±0.20	3.10 ±0.20	1.50 ±0.20

(mm)

### Devices Per Unit

Package Type	Unit	Quantity
SOT-23-5	Tape & Reel	3000

**Reflow Condition (IR/Convection or VPR Reflow)**

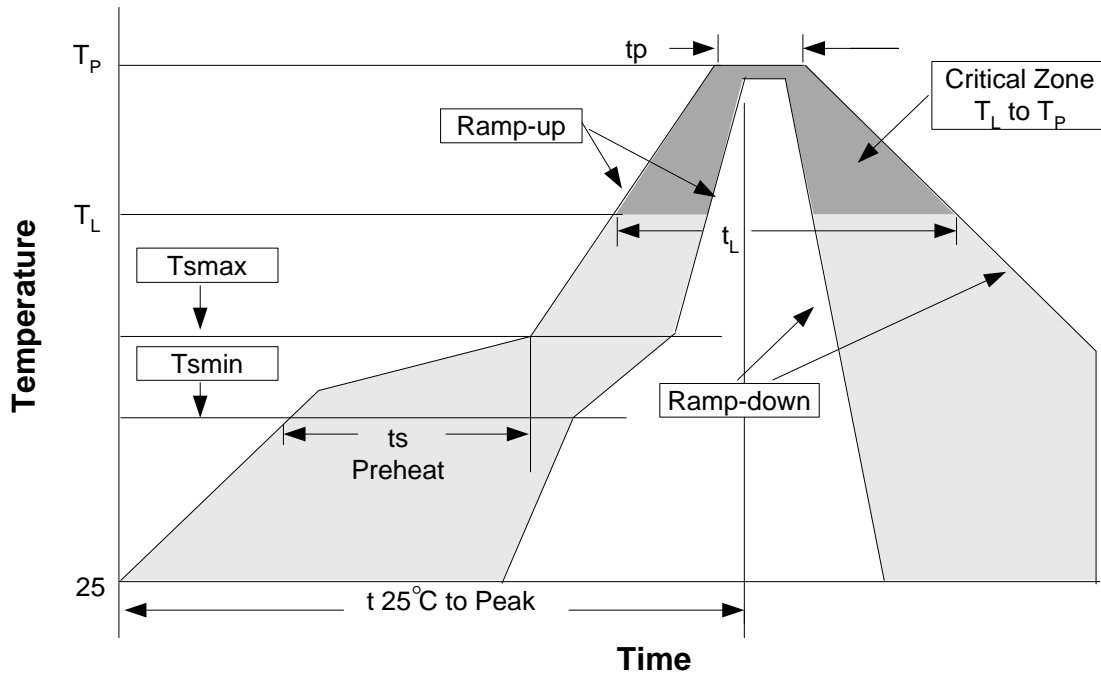

**Reliability Test Program**

Test item	Method	Description
SOLDERABILITY	MIL-STD-883D-2003	245°C, 5 sec
HOLT	MIL-STD-883D-1005.7	1000 Hrs Bias @ 125°C
PCT	JESD-22-B, A102	168 Hrs, 100%RH, 121°C
TST	MIL-STD-883D-1011.9	-65°C~150°C, 200 Cycles
ESD	MIL-STD-883D-3015.7	VHBM > 2KV, VMM > 200V
Latch-Up	JESD 78	10ms, 1 <sub>tr</sub> > 100mA

**Classification Reflow Profiles**

Profile Feature	Sn-Pb Eutectic Assembly	Pb-Free Assembly
Average ramp-up rate (T <sub>L</sub> to T <sub>P</sub> )	3°C/second max.	3°C/second max.
Preheat		
- Temperature Min (T <sub>min</sub> )	100°C	150°C
- Temperature Max (T <sub>max</sub> )	150°C	200°C
- Time (min to max) (t <sub>s</sub> )	60-120 seconds	60-180 seconds
Time maintained above:		
- Temperature (T <sub>L</sub> )	183°C	217°C
- Time (t <sub>L</sub> )	60-150 seconds	60-150 seconds
Peak/Classification Temperature (T <sub>p</sub> )	See table 1	See table 2
Time within 5°C of actual Peak Temperature (t <sub>p</sub> )	10-30 seconds	20-40 seconds
Ramp-down Rate	6°C/second max.	6°C/second max.
Time 25°C to Peak Temperature	6 minutes max.	8 minutes max.

Note: All temperatures refer to topside of the package. Measured on the body surface.

## Classification Reflow Profiles (Cont.)

Table 1. SnPb Eutectic Process – Package Peak Reflow Temperatures

Package Thickness	Volume mm <sup>3</sup> <350	Volume mm <sup>3</sup> ≥350
<2.5 mm	240 +0/-5°C	225 +0/-5°C
≥2.5 mm	225 +0/-5°C	225 +0/-5°C

Table 2. Pb-free Process – Package Classification Reflow Temperatures

Package Thickness	Volume mm <sup>3</sup> <350	Volume mm <sup>3</sup> 350-2000	Volume mm <sup>3</sup> >2000
<1.6 mm	260 +0°C*	260 +0°C*	260 +0°C*
1.6 mm – 2.5 mm	260 +0°C*	250 +0°C*	245 +0°C*
≥2.5 mm	250 +0°C*	245 +0°C*	245 +0°C*

\*Tolerance: The device manufacturer/supplier **shall** assure process compatibility up to and including the stated classification temperature (this means Peak reflow temperature +0°C. For example 260°C+0°C) at the rated MSL level.

## Customer Service

### Anpec Electronics Corp.

Head Office :

No.6, Dusing 1st Road, SBIP,  
Hsin-Chu, Taiwan  
Tel : 886-3-5642000  
Fax : 886-3-5642050

Taipei Branch :

2F, No. 11, Lane 218, Sec 2 Jhongsing Rd.,  
Sindian City, Taipei County 23146, Taiwan  
Tel : 886-2-2910-3838  
Fax : 886-2-2917-3838