

RNA51953A,B

Voltage Detecting, System Resetting IC Series

REJ03D0911-0100
Rev.1.00
Oct 10, 2008

Description

RNA51953A,B are semiconductor integrated circuits designed for detecting supply voltage and resetting all types of logic circuits such as CPUs.

They include a built-in delay circuit to provide the desired retardation time simply by adding an external capacitor.

They find extensive applications, including battery checking circuit, level detecting circuit and waveform shaping circuit.

Features

- Few external parts
- Large delay time with a capacitor of small capacitance ($t_d \approx 100$ ms, at $0.33 \mu\text{F}$)
- Low threshold operating voltage (Supply voltage to keep low-state at low supply voltage):
0.6 V (Typ) at $R_L = 22 \text{ k}\Omega$
- Wide supply voltage range: 2 V to 17 V
- Wide application range
- Ordering Information

Part Name	Package Type	Package Code	Package Abbreviation	Taping Abbreviation (Quantity)	Surface Treatment
RNA51953AFPH0	SOP-8 pin	PRSP0008DE-C	FP	H (2,500 pcs / Reel)	0 (Ni/Pd/Au)
RNA51953BFPH0	SOP-8 pin	PRSP0008DE-C	FP	H (2,500 pcs / Reel)	0 (Ni/Pd/Au)

Application

- Reset circuit of Pch, Nch, CMOS, microcomputer, CPU and MCU, Reset of logic circuit, Battery check circuit, switching circuit back-up voltage, level detecting circuit, waveform shaping circuit, delay waveform generating circuit, DC/DC converter, over voltage protection circuit

Recommended Operating Condition

- Supply voltage range: 2 V to 17 V

Outline and Article Indication

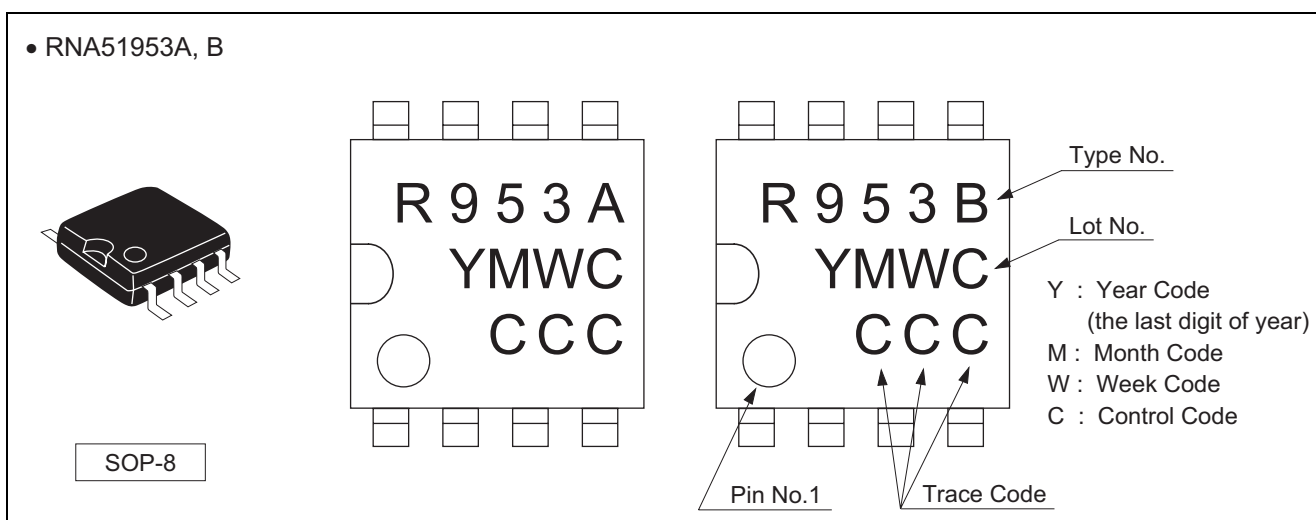

Pin Arrangement

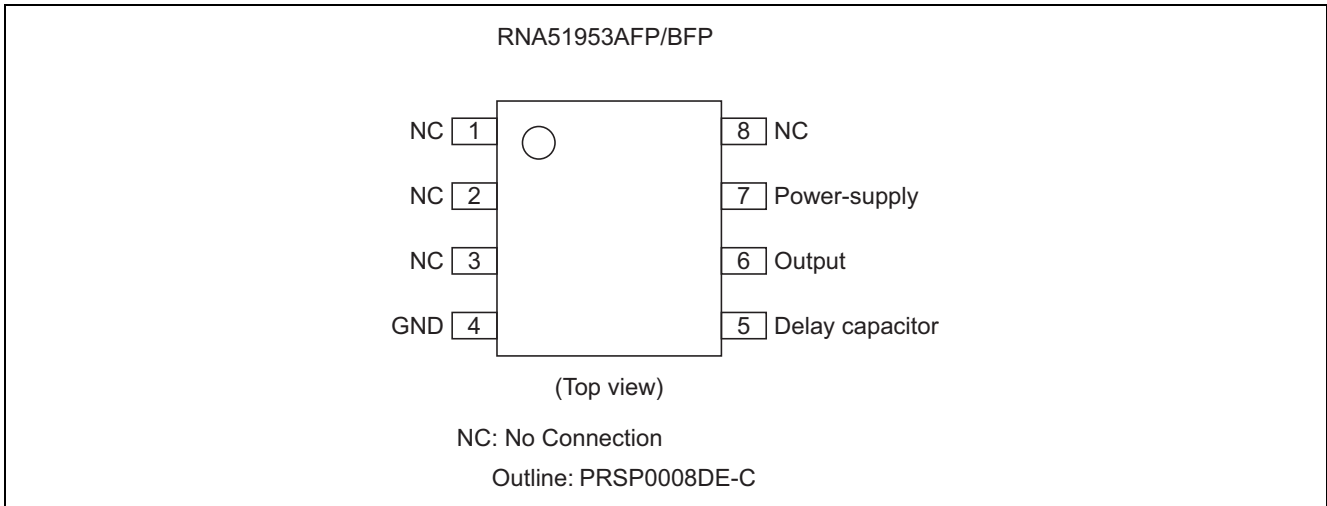

Block Diagram

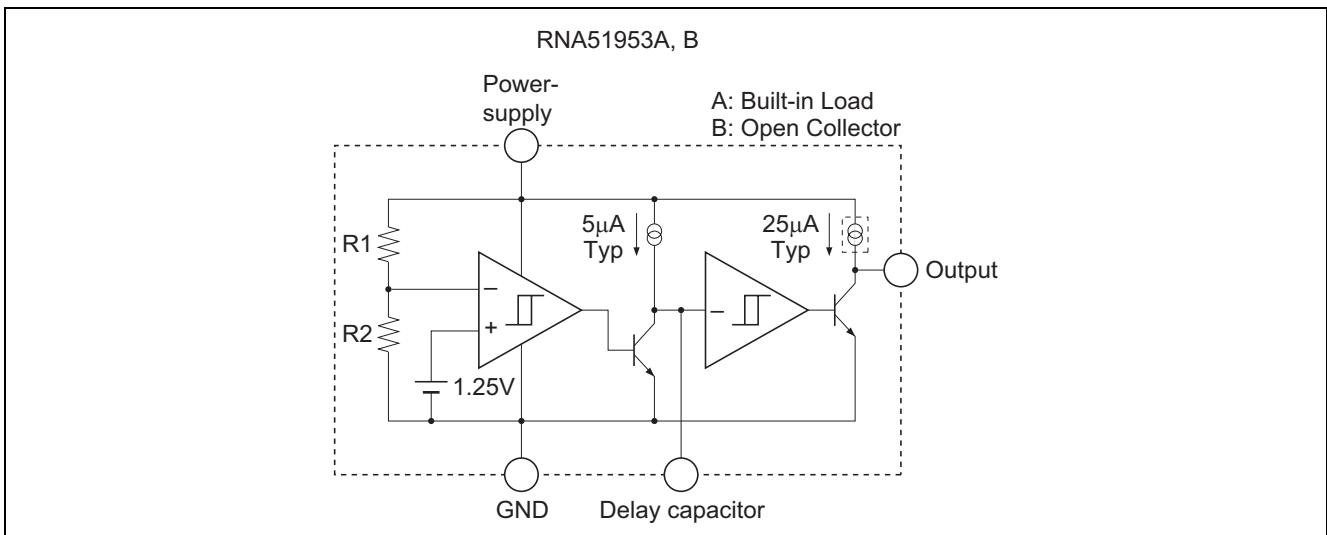

Operating Waveform

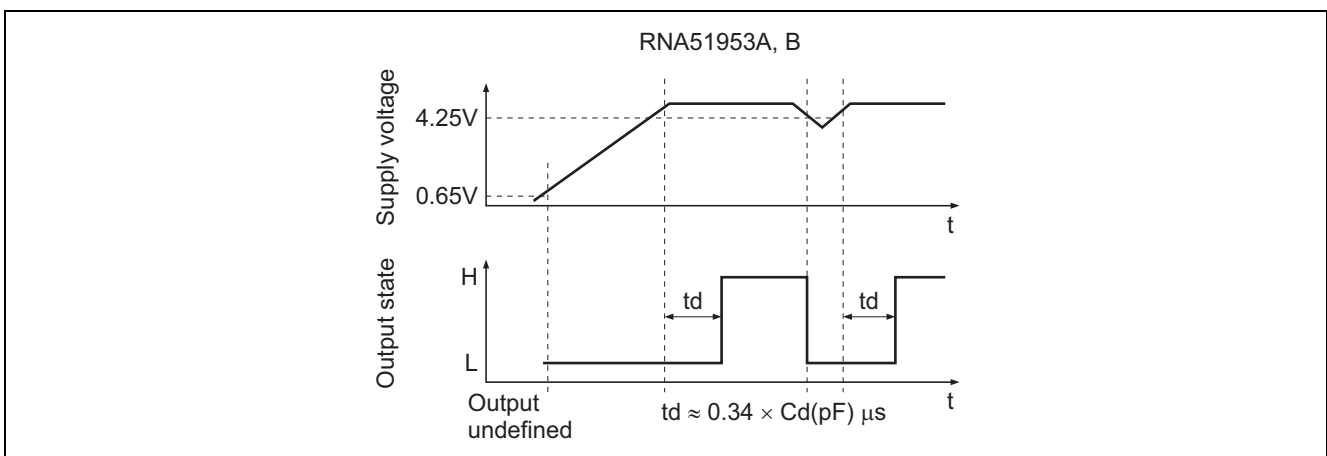

Absolute Maximum Ratings

(Ta = 25°C, unless otherwise noted)

Item	Symbol	Ratings	Unit	Conditions
Supply voltage	V _{CC}	18	V	
Output sink current	I _{sink}	6	mA	
Output voltage	V _O	V _{CC}	V	Type A (output with constant current load)
		18		Type B (open collector output)
Power dissipation	P _d	400	mW	8-pin SOP (PRSP0008DE-C)
Thermal derating	K _θ	4.4	mW/°C	Refer to the thermal derating curve. 8-pin SOP (PRSP0008DE-C)
Operating temperature	Topr	-40 to +85	°C	
Storage temperature	Tstg	-55 to +125	°C	

Electrical Characteristics

(Ta = 25°C, unless otherwise noted)

- “L” reset type

Item	Symbol	Min	Typ	Max	Unit	Test Conditions
Detecting voltage	V _S	4.05	4.25	4.45	V	
Hysteresis voltage	ΔV _S	30	50	80	mV	
Detecting voltage temperature coefficient	V _S /ΔT	—	0.01	—	%/°C	
Circuit current	I _{CC}	—	450	680	μA	Type A, V _{CC} = 5V
		—	420	630		Type B, V _{CC} = 5V
Delay time	t _{pd}	1.6	3.4	7.0	ms	Cd = 0.01 μF *
Constant current	I _{pd}	-8	-5	-3	μA	V _{CC} = 5V
Output saturation voltage	V _{sat}	—	0.2	0.4	V	V _{CC} = 4V, I _{sink} = 4mA
Threshold operating voltage	V _{OPL}	—	0.67	0.8	V	R _L = 2.2kΩ, V _{sat} ≤ 0.4V
		—	0.55	0.7		R _L = 100kΩ, V _{sat} ≤ 0.4V
Output leakage current	I _{OH}	—	—	30	nA	Type B
Output load current	I _{OC}	-40	-25	-17	μA	Type A, V _{CC} = 5V, V _O = 1/2 × V _{CC}
Output high voltage	V _{OH}	V _{CC} -0.2	V _{CC} -0.06	—	V	Type A

Note: Please set the desired delay time by attaching capacitor of the range between 4700 pF and 10 μF.

Typical Characteristics

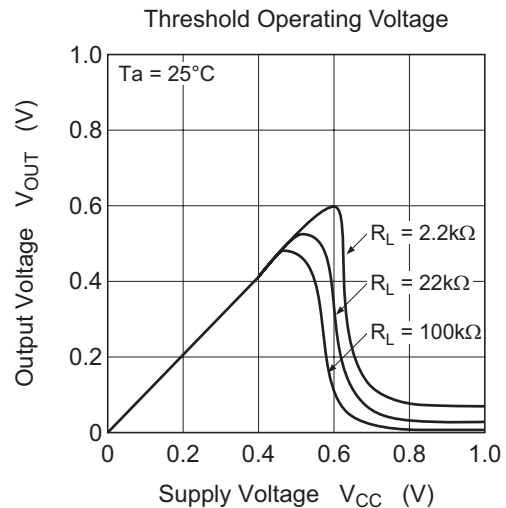
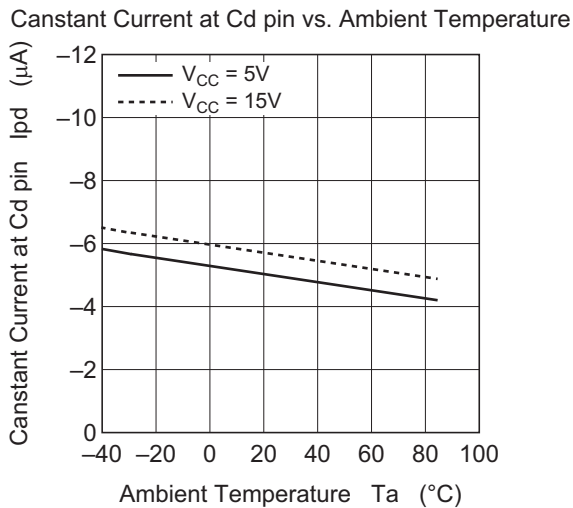
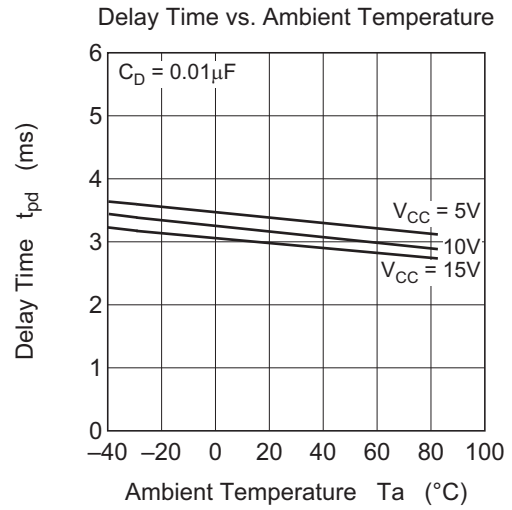
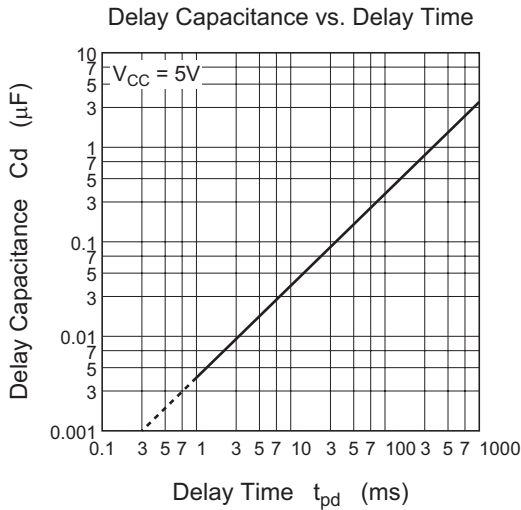
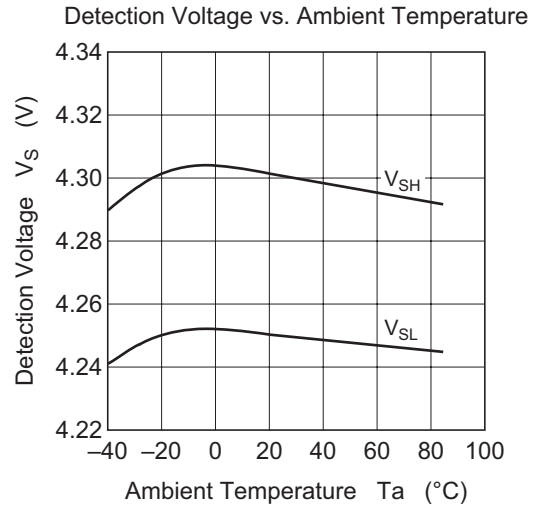
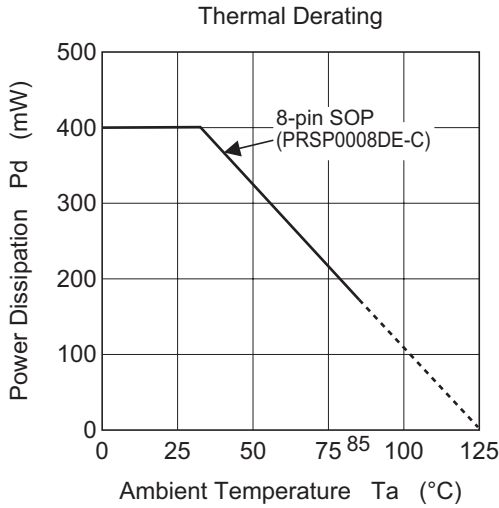

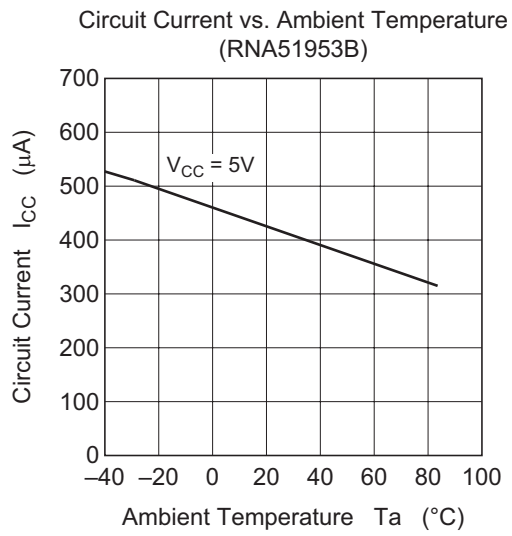
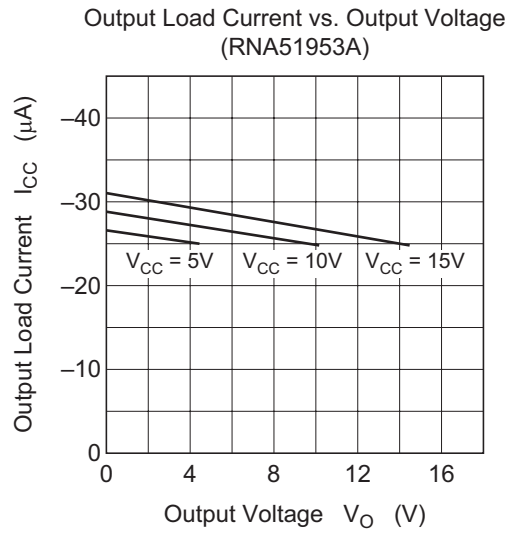
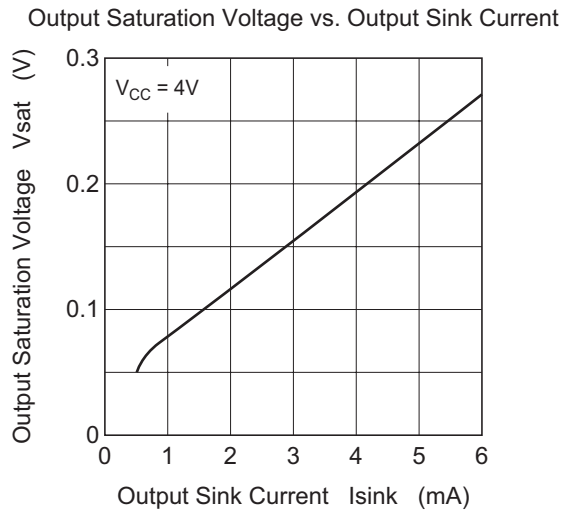

Example of Application Circuit

Reset Circuit of RNA51953

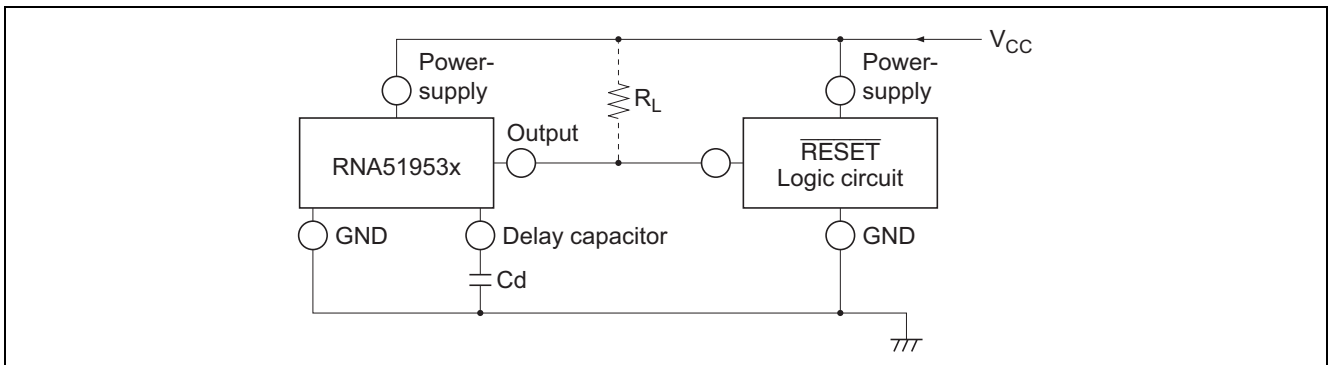

Figure 1 Reset Circuit of RNA51953

- Notes:
1. When the voltage is anything except 4.25 V, RNA51957 are used. In this case, the detecting supply voltage is $1.25 \times (R_1 + R_2) / R_2$ (V) approximately. The detecting supply voltage can be set between 2 V and 15 V.
 2. The delay time is about $0.34 \times C_d$ (pF) μ s.
 3. If the RNA51953 and the logic circuit share a common power source, type A (built-in load type) can be used whether a pull-up resistor is included in the logic circuit or not.
 4. The logic circuit preferably should not have a pull-down resistor, but if one is present, add load resistor R_L to overcome the pull-down resistor.
 5. When the reset terminal in the logic circuit is of the low reset type, RNA51953 and RNA51957 are used.
 6. When a negative supply voltage is used, the supply voltage side of RNA51953 and the GND side are connected to negative supply voltage respectively.

Case of Using Reset Signal except Supply Voltage in the RNA51953

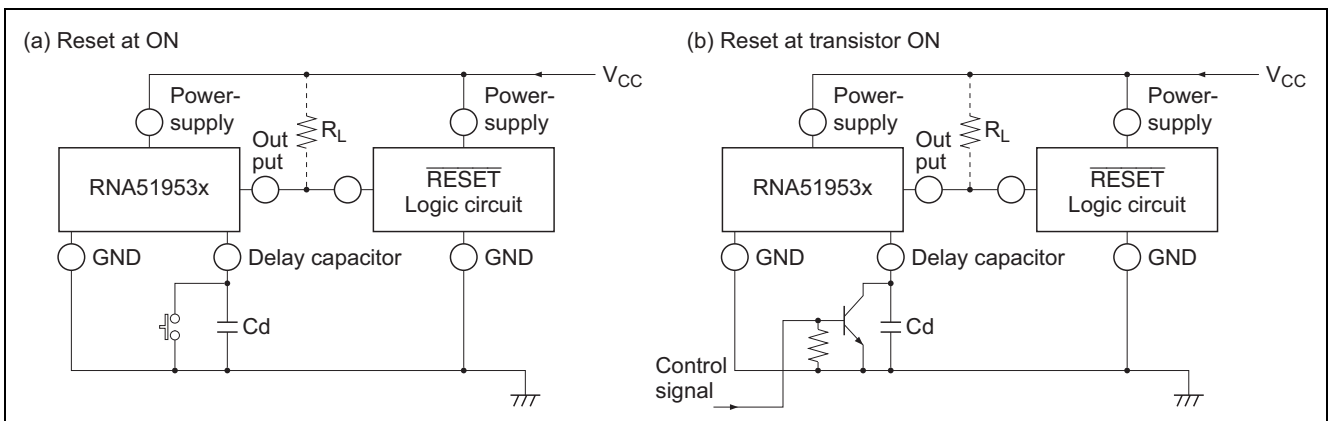

Figure 2 Case of Using Reset Signal except Supply Voltage in the RNA51953

Notice for use

About the Power Supply Line

1. About bypass capacitor

Because the ripple and the spike of the high frequency noise and the low frequency are superimposed to the power supply line, it is necessary to remove these.

Therefore, please install C_1 and C_2 for the low frequency and for the high frequency between the power supply line and the GND line as shown in following figure 3.

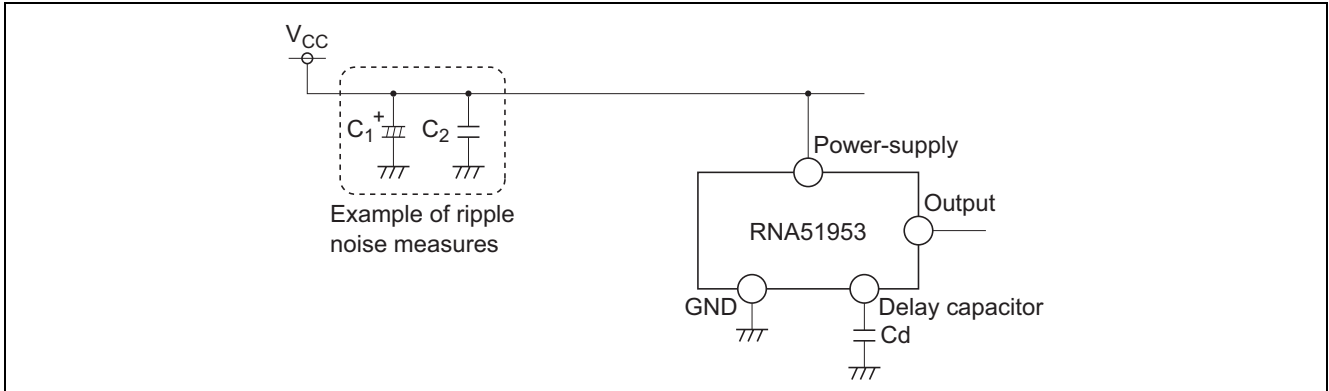

Figure 3 Example of Ripple Noise Measures

Setting of Delay Capacity

Please use capacitor C_d for the delay within the range of 10 μ F or less.

When a value that is bigger than this is set, the problem such as following (1), (2), and (3) becomes remarkable.

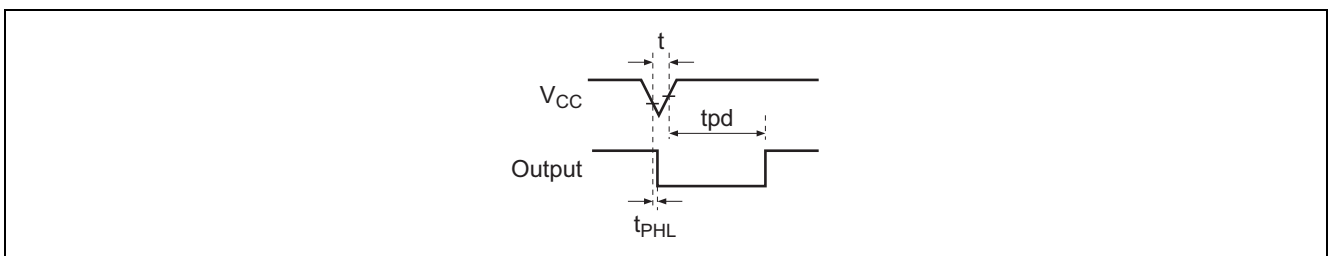

Figure 4 Time Chart at Momentary Voltage-Decrease

(1) The difference at delay time becomes remarkable.

A long delay setting of tens of seconds is fundamentally possible. However, when set delay time is lengthened, the range of the difference relatively grows, too. When a set value is assumed to be 'tpd', the difference occurs in the range from $0.47 \times t_{pd}$ to $2.05 \times t_{pd}$. For instance, 34 seconds can be calculated at 100 μ F. However, it is likely to vary within the ranges of 16-70 seconds.

(2) Difficulty to react to a momentary voltage decrease.

For example, the reaction time t_{PHL} is 10 μ s when delay capacitor $C_d = 0.1 \mu$ F.

The momentary voltage-decrease that is longer than such t_{PHL} are occurs, the detection becomes possible. When the delay capacitance is enlarged, t_{PHL} also becomes long. For instance, it becomes about 100 to 200 μ s in case of circuit constant $C_1 = 100 \mu$ F.

(Characteristic graph 1 is used and extrapolation in case of $C_d = 100 \mu$ F.)

Therefore, it doesn't react to momentary voltage-decrease that is shorter than this.

(3) Original delay time is not obtained.

When the momentary voltage-decrease time 't' is equivalent to t_{PHL} , the discharge becomes insufficient and the charge starts at that state. This phenomenon occurs at large capacitance. And, original delay time tpd is not obtained.

Please refer to characteristic graph 2. (Delay time versus input pulse width)

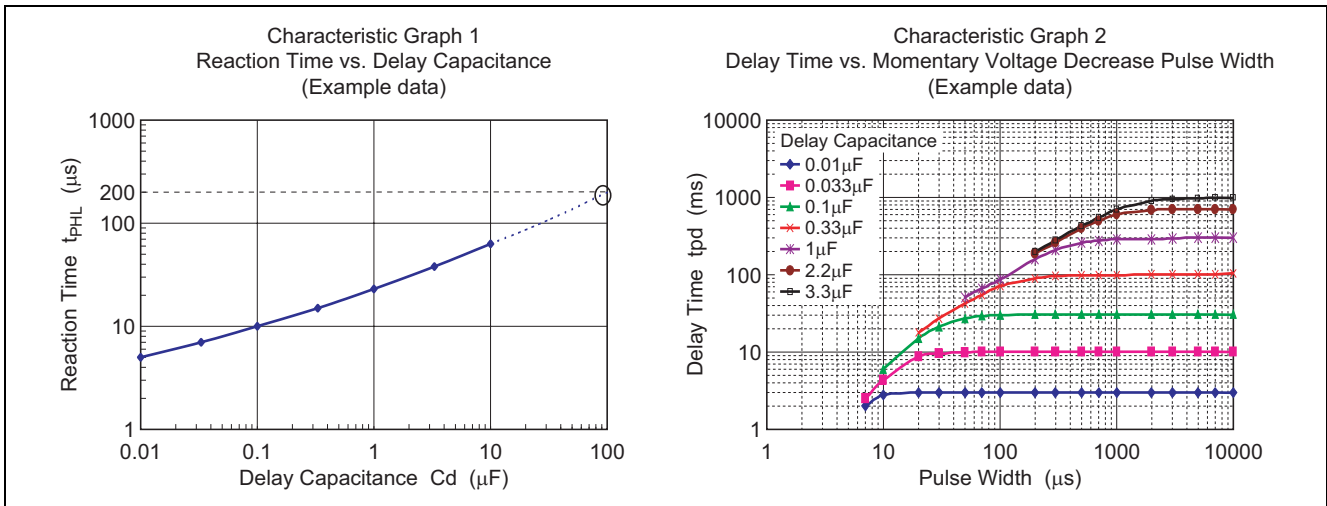

Figure 5 Characteristic Graph

Setting of Output Load Resistance (RNA51953B)

High level output voltage can be set without depending on the power-supply voltage because the output terminal is an open collector type. However, please guard the following notes.

1. Please set it in value (2 V to 17 V) within the range of the power-supply voltage recommendation. Moreover, please never impress the voltage of maximum ratings 18 V or more even momentarily either.
2. Please set output load resistance (pull-up resistance) R_L so that the output current (output inflow current I_L) at L level may become 4 mA or less. Moreover, please never exceed absolute maximum rating (6 mA).

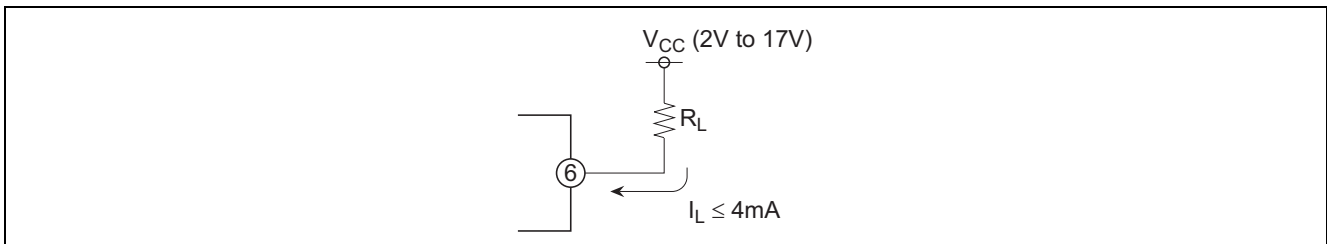

Figure 6 Output Load Resistance R_L

Others

1. Notes when IC is handled are published in our reliability handbook, and please refer it. The reliability handbook can be downloaded from our homepage (following URL). http://www.renesas.com/fmwk.jsp?cnt=reliability_root.jsp&fp=/products/common_info/reliability
2. Additionally, please inquire of our company when there is an uncertain point on use.

Package Dimensions

JEITA Package Code	RENESAS Code	Previous Code	MASS[Typ.]
P-SOP8-4.4x4.85-1.27	PRSP0008DE-C	—	0.1g

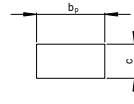
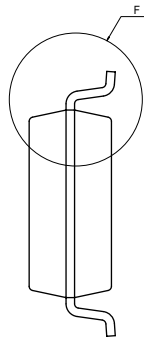
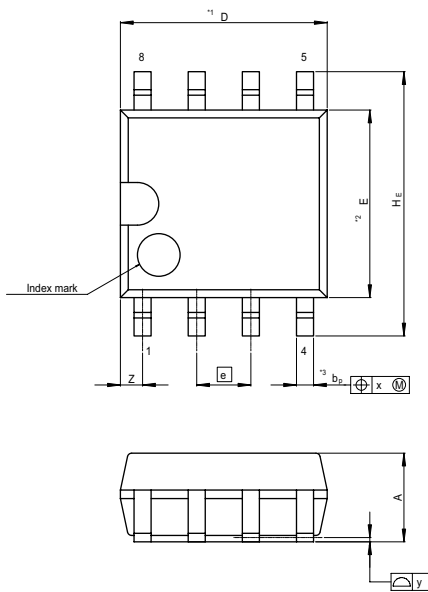

Terminal cross section
(Ni/Pd/Au plating)

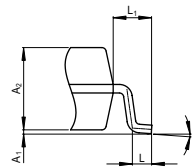

Detail F

NOTE)
1. DIMENSIONS 11 (Nom) AND 22
DO NOT INCLUDE MOLD FLASH.
2. DIMENSION 33 DOES NOT
INCLUDE TRIM OFFSET.

Reference Symbol	Dimension in Millimeters		
	Min	Nom	Max
D	4.65	4.85	5.05
E	4.2	4.4	4.6
A ₂	—	1.85	—
A ₁	0.00	0.1	0.20
A	—	—	2.03
b _p	0.34	0.4	0.46
b ₁	—	—	—
c	0.15	0.20	0.25
c ₁	—	—	—
θ	0°	—	8°
H _E	5.7	6.2	6.5
Ⓢ	1.12	1.27	1.42
x	—	—	0.12
y	—	—	0.10
Z	—	—	0.75
L	0.25	0.45	0.65
L ₁	—	0.90	—

Notes:

1. This document is provided for reference purposes only so that Renesas customers may select the appropriate Renesas products for their use. Renesas neither makes warranties or representations with respect to the accuracy or completeness of the information contained in this document nor grants any license to any intellectual property rights or any other rights of Renesas or any third party with respect to the information in this document.
2. Renesas shall have no liability for damages or infringement of any intellectual property or other rights arising out of the use of any information in this document, including, but not limited to, product data, diagrams, charts, programs, algorithms, and application circuit examples.
3. You should not use the products or the technology described in this document for the purpose of military applications such as the development of weapons of mass destruction or for the purpose of any other military use. When exporting the products or technology described herein, you should follow the applicable export control laws and regulations, and procedures required by such laws and regulations.
4. All information included in this document such as product data, diagrams, charts, programs, algorithms, and application circuit examples, is current as of the date this document is issued. Such information, however, is subject to change without any prior notice. Before purchasing or using any Renesas products listed in this document, please confirm the latest product information with a Renesas sales office. Also, please pay regular and careful attention to additional and different information to be disclosed by Renesas such as that disclosed through our website. (<http://www.renesas.com>)
5. Renesas has used reasonable care in compiling the information included in this document, but Renesas assumes no liability whatsoever for any damages incurred as a result of errors or omissions in the information included in this document.
6. When using or otherwise relying on the information in this document, you should evaluate the information in light of the total system before deciding about the applicability of such information to the intended application. Renesas makes no representations, warranties or guarantees regarding the suitability of its products for any particular application and specifically disclaims any liability arising out of the application and use of the information in this document or Renesas products.
7. With the exception of products specified by Renesas as suitable for automobile applications, Renesas products are not designed, manufactured or tested for applications or otherwise in systems the failure or malfunction of which may cause a direct threat to human life or create a risk of human injury or which require especially high quality and reliability such as safety systems, or equipment or systems for transportation and traffic, healthcare, combustion control, aerospace and aeronautics, nuclear power, or undersea communication transmission. If you are considering the use of our products for such purposes, please contact a Renesas sales office beforehand. Renesas shall have no liability for damages arising out of the uses set forth above.
8. Notwithstanding the preceding paragraph, you should not use Renesas products for the purposes listed below:
 - (1) artificial life support devices or systems
 - (2) surgical implantations
 - (3) healthcare intervention (e.g., excision, administration of medication, etc.)
 - (4) any other purposes that pose a direct threat to human lifeRenesas shall have no liability for damages arising out of the uses set forth in the above and purchasers who elect to use Renesas products in any of the foregoing applications shall indemnify and hold harmless Renesas Technology Corp., its affiliated companies and their officers, directors, and employees against any and all damages arising out of such applications.
9. You should use the products described herein within the range specified by Renesas, especially with respect to the maximum rating, operating supply voltage range, movement power voltage range, heat radiation characteristics, installation and other product characteristics. Renesas shall have no liability for malfunctions or damages arising out of the use of Renesas products beyond such specified ranges.
10. Although Renesas endeavors to improve the quality and reliability of its products, IC products have specific characteristics such as the occurrence of failure at a certain rate and malfunctions under certain use conditions. Please be sure to implement safety measures to guard against the possibility of physical injury, and injury or damage caused by fire in the event of the failure of a Renesas product, such as safety design for hardware and software including but not limited to redundancy, fire control and malfunction prevention, appropriate treatment for aging degradation or any other applicable measures. Among others, since the evaluation of microcomputer software alone is very difficult, please evaluate the safety of the final products or system manufactured by you.
11. In case Renesas products listed in this document are detached from the products to which the Renesas products are attached or affixed, the risk of accident such as swallowing by infants and small children is very high. You should implement safety measures so that Renesas products may not be easily detached from your products. Renesas shall have no liability for damages arising out of such detachment.
12. This document may not be reproduced or duplicated, in any form, in whole or in part, without prior written approval from Renesas.
13. Please contact a Renesas sales office if you have any questions regarding the information contained in this document, Renesas semiconductor products, or if you have any other inquiries.



RENESAS SALES OFFICES

<http://www.renesas.com>

Refer to "<http://www.renesas.com/en/network>" for the latest and detailed information.

Renesas Technology America, Inc.
450 Holger Way, San Jose, CA 95134-1368, U.S.A
Tel: <1> (408) 382-7500, Fax: <1> (408) 382-7501

Renesas Technology Europe Limited
Dukes Meadow, Millboard Road, Bourne End, Buckinghamshire, SL8 5FH, U.K.
Tel: <44> (1628) 585-100, Fax: <44> (1628) 585-900

Renesas Technology (Shanghai) Co., Ltd.
Unit 204, 205, AZIACenter, No.1233 Lujiazui Ring Rd, Pudong District, Shanghai, China 200120
Tel: <86> (21) 5877-1818, Fax: <86> (21) 6887-7858/7898

Renesas Technology Hong Kong Ltd.
7th Floor, North Tower, World Finance Centre, Harbour City, Canton Road, Tsimshatsui, Kowloon, Hong Kong
Tel: <852> 2265-6688, Fax: <852> 2377-3473

Renesas Technology Taiwan Co., Ltd.
10th Floor, No.99, Fushing North Road, Taipei, Taiwan
Tel: <886> (2) 2715-2888, Fax: <886> (2) 3518-3399

Renesas Technology Singapore Pte. Ltd.
1 Harbour Front Avenue, #06-10, Keppel Bay Tower, Singapore 098632
Tel: <65> 6213-0200, Fax: <65> 6278-8001

Renesas Technology Korea Co., Ltd.
Kukje Center Bldg. 18th Fl., 191, 2-ka, Hangang-ro, Yongsan-ku, Seoul 140-702, Korea
Tel: <82> (2) 796-3115, Fax: <82> (2) 796-2145

Renesas Technology Malaysia Sdn. Bhd
Unit 906, Block B, Menara Amcorp, Amcorp Trade Centre, No.18, Jln Persiaran Barat, 46050 Petaling Jaya, Selangor Darul Ehsan, Malaysia
Tel: <603> 7955-9390, Fax: <603> 7955-9510