

The revision list can be viewed directly by clicking the title page.  
The revision list summarizes the locations of revisions and additions. Details should always be checked by referring to the relevant text.

## 16

## H8S/2194 Group, H8S/2194C Group, H8S/2194F-ZTAT™, H8S/2194C F-ZTAT™ Hardware Manual

### Renesas 16-Bit Single-Chip Microcomputer H8S Family/H8S/2100 Series

H8S/2194	HD6432194
	HD64F2194
H8S/2193	HD6432193
H8S/2192	HD6432192
H8S/2191	HD6432191
H8S/2194C	HD6432194C
	HD64F2194C
H8S/2194B	HD6432194B
H8S/2194A	HD6432194A

## Notes regarding these materials

1. This document is provided for reference purposes only so that Renesas customers may select the appropriate Renesas products for their use. Renesas neither makes warranties or representations with respect to the accuracy or completeness of the information contained in this document nor grants any license to any intellectual property rights or any other rights of Renesas or any third party with respect to the information in this document.
2. Renesas shall have no liability for damages or infringement of any intellectual property or other rights arising out of the use of any information in this document, including, but not limited to, product data, diagrams, charts, programs, algorithms, and application circuit examples.
3. You should not use the products or the technology described in this document for the purpose of military applications such as the development of weapons of mass destruction or for the purpose of any other military use. When exporting the products or technology described herein, you should follow the applicable export control laws and regulations, and procedures required by such laws and regulations.
4. All information included in this document such as product data, diagrams, charts, programs, algorithms, and application circuit examples, is current as of the date this document is issued. Such information, however, is subject to change without any prior notice. Before purchasing or using any Renesas products listed in this document, please confirm the latest product information with a Renesas sales office. Also, please pay regular and careful attention to additional and different information to be disclosed by Renesas such as that disclosed through our website. (<http://www.renesas.com>)
5. Renesas has used reasonable care in compiling the information included in this document, but Renesas assumes no liability whatsoever for any damages incurred as a result of errors or omissions in the information included in this document.
6. When using or otherwise relying on the information in this document, you should evaluate the information in light of the total system before deciding about the applicability of such information to the intended application. Renesas makes no representations, warranties or guaranties regarding the suitability of its products for any particular application and specifically disclaims any liability arising out of the application and use of the information in this document or Renesas products.
7. With the exception of products specified by Renesas as suitable for automobile applications, Renesas products are not designed, manufactured or tested for applications or otherwise in systems the failure or malfunction of which may cause a direct threat to human life or create a risk of human injury or which require especially high quality and reliability such as safety systems, or equipment or systems for transportation and traffic, healthcare, combustion control, aerospace and aeronautics, nuclear power, or undersea communication transmission. If you are considering the use of our products for such purposes, please contact a Renesas sales office beforehand. Renesas shall have no liability for damages arising out of the uses set forth above.
8. Notwithstanding the preceding paragraph, you should not use Renesas products for the purposes listed below:
  - (1) artificial life support devices or systems
  - (2) surgical implantations
  - (3) healthcare intervention (e.g., excision, administration of medication, etc.)
  - (4) any other purposes that pose a direct threat to human lifeRenesas shall have no liability for damages arising out of the uses set forth in the above and purchasers who elect to use Renesas products in any of the foregoing applications shall indemnify and hold harmless Renesas Technology Corp., its affiliated companies and their officers, directors, and employees against any and all damages arising out of such applications.
9. You should use the products described herein within the range specified by Renesas, especially with respect to the maximum rating, operating supply voltage range, movement power voltage range, heat radiation characteristics, installation and other product characteristics. Renesas shall have no liability for malfunctions or damages arising out of the use of Renesas products beyond such specified ranges.
10. Although Renesas endeavors to improve the quality and reliability of its products, IC products have specific characteristics such as the occurrence of failure at a certain rate and malfunctions under certain use conditions. Please be sure to implement safety measures to guard against the possibility of physical injury, and injury or damage caused by fire in the event of the failure of a Renesas product, such as safety design for hardware and software including but not limited to redundancy, fire control and malfunction prevention, appropriate treatment for aging degradation or any other applicable measures. Among others, since the evaluation of microcomputer software alone is very difficult, please evaluate the safety of the final products or system manufactured by you.
11. In case Renesas products listed in this document are detached from the products to which the Renesas products are attached or affixed, the risk of accident such as swallowing by infants and small children is very high. You should implement safety measures so that Renesas products may not be easily detached from your products. Renesas shall have no liability for damages arising out of such detachment.
12. This document may not be reproduced or duplicated, in any form, in whole or in part, without prior written approval from Renesas.
13. Please contact a Renesas sales office if you have any questions regarding the information contained in this document, Renesas semiconductor products, or if you have any other inquiries.

## General Precautions in the Handling of MPU/MCU Products

The following usage notes are applicable to all MPU/MCU products from Renesas. For detailed usage notes on the products covered by this manual, refer to the relevant sections of the manual. If the descriptions under General Precautions in the Handling of MPU/MCU Products and in the body of the manual differ from each other, the description in the body of the manual takes precedence.

### 1. Handling of Unused Pins

Handle unused pins in accord with the directions given under Handling of Unused Pins in the manual.

- The input pins of CMOS products are generally in the high-impedance state. In operation with an unused pin in the open-circuit state, extra electromagnetic noise is induced in the vicinity of LSI, an associated shoot-through current flows internally, and malfunctions may occur due to the false recognition of the pin state as an input signal. Unused pins should be handled as described under Handling of Unused Pins in the manual.

### 2. Processing at Power-on

The state of the product is undefined at the moment when power is supplied.

- The states of internal circuits in the LSI are indeterminate and the states of register settings and pins are undefined at the moment when power is supplied.

In a finished product where the reset signal is applied to the external reset pin, the states of pins are not guaranteed from the moment when power is supplied until the reset process is completed.

In a similar way, the states of pins in a product that is reset by an on-chip power-on reset function are not guaranteed from the moment when power is supplied until the power reaches the level at which resetting has been specified.

### 3. Prohibition of Access to Reserved Addresses

Access to reserved addresses is prohibited.

- The reserved addresses are provided for the possible future expansion of functions. Do not access these addresses; the correct operation of LSI is not guaranteed if they are accessed.

### 4. Clock Signals

After applying a reset, only release the reset line after the operating clock signal has become stable. When switching the clock signal during program execution, wait until the target clock signal has stabilized.

- When the clock signal is generated with an external resonator (or from an external oscillator) during a reset, ensure that the reset line is only released after full stabilization of the clock signal. Moreover, when switching to a clock signal produced with an external resonator (or by an external oscillator) while program execution is in progress, wait until the target clock signal is stable.

### 5. Differences between Products

Before changing from one product to another, i.e. to one with a different type number, confirm that the change will not lead to problems.

- The characteristics of MPU/MCU in the same group but having different type numbers may differ because of the differences in internal memory capacity and layout pattern. When changing to products of different type numbers, implement a system-evaluation test for each of the products.



# Main Revisions for This Edition

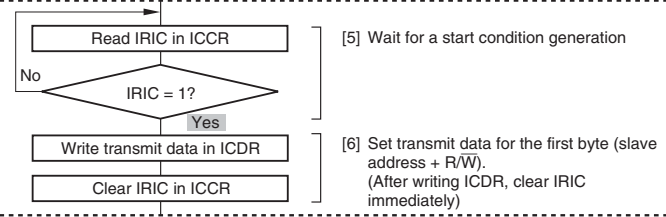
Item	Page	Revision (See Manual for Details)
All	—	<ul style="list-style-type: none"> <li>Notification of change in company name amended (Before) Hitachi, Ltd. → (After) Renesas Technology Corp.</li> <li>Product naming convention amended (Before) H8S/2194 Series → (After) H8S/2194 Group (Before) H8S/2194C Series → (After) H8S/2194C Group</li> </ul>
2.8.1 Overview	54	Figure 2.15 amended
Figure 2.15 State Transitions		$\overline{RES}$ = High SLEEP instruction with LSON = 0, TMA3 = 0, SSBY = 0
4.2.3 Timer Register A (TMA)	79	Table amended <ul style="list-style-type: none"> <li>Timer A counts <math>\phi</math>-based prescalar (PSS) divided clock pulses</li> <li>Timer A counts <math>\phi_w</math>-based prescalar (PSW) divided clock pulses</li> </ul>
4.6.1 Standby Mode	83	Description amended ... RAM as well as functions of the SCI1, timer X1 ...
4.6.2 Clearing Standby Mode	83	(1) Clearing with an Interrupt ... in bits STS2 to STS0 in SBYCR, stable clocks are supplied ...
6.2.6 Port Mode Register (PMR1)	106	Table amended P1n/ $\overline{IRQn}$ pin functions as the $\overline{IRQn}$ input pin
7.2.5 Register Configuration	132	Access size description deleted from table 7.3
Table 7.3 Flash Memory Registers		
7.4.1 Boot Mode	143	(1) Automatic SCI Bit Rate Adjustment Description amended ... bit rate should be set to (4800, or 9600) bps. ...
8.4.1 Boot Mode	191	(1) Automatic SCI Bit Rate Adjustment Description amended ... bit rate should be set to (4800, or 9600) bps. ...
8.5 Programming/Erasing Flash Memory	195	Description amended ... PSU2, ESU2, P2, E2, PV2, and EV2 bits in FLMCR2. ...

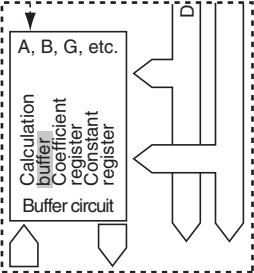
Item	Page	Revision (See Manual for Details)																																								
8.5.1 Program Mode (n = 1 for addresses H'00000 to H'1FFFF and n= 2 for addresses H'20000 to H'3FFFF)	195	Section 8.5.1 title amended																																								
8.5.3 Erase Mode (n = 1 for Addresses H'00000 to H'1FFFF and N = 2 for Addresses H'20000 to H'3FFFF)	198	Description amended ... is switched to erase mode by setting the En bit in FLMCRn. The time during ...																																								
8.8.1 Program Mode Setting	205	Description amended ... Renesas Technology microcomputer device type with 256-kbyte on-chip flash memory. ...																																								
8.8.3 Programmer Mode Operation	206	Table 8.10 amended																																								
Table 8.10 Settings for Each Operating Mode in Programmer Mode		<table border="1"> <thead> <tr> <th rowspan="2">Mode</th> <th rowspan="2">FWE</th> <th colspan="5">Pin Names</th> <th rowspan="2">FA0 to FA17</th> </tr> <tr> <th>CE</th> <th>OE</th> <th>WE</th> <th>FO0 to FO7</th> </tr> </thead> <tbody> <tr> <td>Read</td> <td>H or L</td> <td>L</td> <td>L</td> <td>H</td> <td>Data output</td> <td>Ain</td> </tr> <tr> <td>Output disable</td> <td>H or L</td> <td>L</td> <td>H</td> <td>H</td> <td>Hi-Z</td> <td>X</td> </tr> <tr> <td>Command write</td> <td>H or L*3</td> <td>L</td> <td>H</td> <td>L</td> <td>Data input</td> <td>Ain*2</td> </tr> <tr> <td>Chip disable*1</td> <td>H or L</td> <td>H</td> <td>X</td> <td>X</td> <td>Hi-Z</td> <td>X</td> </tr> </tbody> </table>	Mode	FWE	Pin Names					FA0 to FA17	CE	OE	WE	FO0 to FO7	Read	H or L	L	L	H	Data output	Ain	Output disable	H or L	L	H	H	Hi-Z	X	Command write	H or L*3	L	H	L	Data input	Ain*2	Chip disable*1	H or L	H	X	X	Hi-Z	X
Mode	FWE	Pin Names					FA0 to FA17																																			
		CE	OE	WE	FO0 to FO7																																					
Read	H or L	L	L	H	Data output	Ain																																				
Output disable	H or L	L	H	H	Hi-Z	X																																				
Command write	H or L*3	L	H	L	Data input	Ain*2																																				
Chip disable*1	H or L	H	X	X	Hi-Z	X																																				
8.8.5 Auto-Program Mode	211	Description amended (d) ... Do not perform transfer after the third cycle.																																								
11.1.2 Port Input	236	Pin description for port 0 in table 11.1 amended																																								
Table 11.1 Port Functions		P07/AN7 to P00/AN0																																								
11.1.3 MOS Pull-Up Transistors	237	Figure 11.1 amended																																								
Figure 11.1 Circuit Configuration of Pin with MOS Pull-Up Transistor																																										
11.2.4 Pin States	240	Table 11.4 amended																																								
Table 11.4 Port 0 Pin States		P07/AN7 to P00/AN0																																								
11.4.1 Overview	248	(1) Port Mode Register 2 (PMR2) Description amended Port mode register 2 (PMR2) controls switching ... If the SCK1, SCK2, SI1, and SI2 input pins are set, ...																																								

Item	Page	Revision (See Manual for Details)																																									
11.10.2 Register Configuration	284	(1) Port Mode Register 8 (PMR8) Description amended Bit 1—P81/EXCAP Pin Switching (PMR81): PMR81 sets whether the P81/EXCAP pin is used as a P81 I/O pin or an EXCAP pin for the capstan external synchronous signal input.																																									
15.2.1 Timer L Mode Register (LMR)	324	Bit figure amended Bits 3 to 0 (Before) LMR → (After) LMR																																									
	325	Bits 2 to 0—Clock Selection Bit table amended (Before) R2 → (After) LMR2																																									
16.2.2 Timer R Mode Register 2 (TMRM2)	335	Bit 7—Selection of Capture Signals of the TMRU-2 (LAT) Bit table amended Captures at the rising edge of the CFG																																									
17.6 Exemplary Uses of the Timer X1	379	Description amended (2) Each time a comparing match occurs, the OLVLA bit and ...																																									
22.1.2 Block Diagram Figure 22.1 Block Diagram of Prescaler Unit	424	Figure 22.1 amended (Before) 2 <sup>8</sup> → (After) 2 <sup>9</sup>																																									
23.2.5 Serial Mode Register (SMR1)	440	Bit 4—Parity Mode (O/E) Bit table amended Odd parity* <sup>2</sup>																																									
23.2.7 Serial Status Register (SSR1)	448	Bit 4—Parity Error (PER) Bit table amended (Before) Bit 4 → (After) Bit 3																																									
23.2.8 Bit Rate Register (BRR1)	452	Table 23.4 amended																																									
Table 23.4 BRR1 Settings for Various Bit Rates (Clock Synchronous Mode)		<table border="1"> <thead> <tr> <th rowspan="2">Bit Rate (bits/s)</th> <th colspan="6">Operating Frequency <math>\phi</math> (MHz)</th> </tr> <tr> <th colspan="2">2</th> <th colspan="2">4</th> <th colspan="2">8</th> </tr> <tr> <th></th> <th>n</th> <th>N</th> <th>n</th> <th>N</th> <th>n</th> <th>N</th> </tr> </thead> <tbody> <tr> <td>110</td> <td>3</td> <td>70</td> <td>—</td> <td>—</td> <td></td> <td></td> </tr> <tr> <td>250</td> <td>2</td> <td>124</td> <td>2</td> <td>249</td> <td>3</td> <td>124</td> </tr> <tr> <td>500</td> <td>1</td> <td>249</td> <td>2</td> <td>124</td> <td>2</td> <td>249</td> </tr> </tbody> </table>	Bit Rate (bits/s)	Operating Frequency $\phi$ (MHz)						2		4		8			n	N	n	N	n	N	110	3	70	—	—			250	2	124	2	249	3	124	500	1	249	2	124	2	249
Bit Rate (bits/s)	Operating Frequency $\phi$ (MHz)																																										
	2		4		8																																						
	n	N	n	N	n	N																																					
110	3	70	—	—																																							
250	2	124	2	249	3	124																																					
500	1	249	2	124	2	249																																					
Table 23.6 Maximum Bit Rate with External Clock Input (Asynchronous Mode)	455	Table 23.6 amended																																									
		<table border="1"> <thead> <tr> <th><math>\phi</math> (MHz)</th> <th>External Input Clock (MHz)</th> <th>Maximum Bit Rate (bits/s)</th> </tr> </thead> <tbody> <tr> <td>6</td> <td>1.500</td> <td>0</td> </tr> <tr> <td></td> <td></td> <td>93750</td> </tr> </tbody> </table>	$\phi$ (MHz)	External Input Clock (MHz)	Maximum Bit Rate (bits/s)	6	1.500	0			93750																																
$\phi$ (MHz)	External Input Clock (MHz)	Maximum Bit Rate (bits/s)																																									
6	1.500	0																																									
		93750																																									

Item	Page	Revision (See Manual for Details)
23.2.9 Serial Interface Mode Register (SCMR1)	457	Bit 0—Serial Communication Interface Mode Select (SMIF) Bit table amended Normal SCI <sub>1</sub> mode
23.3.4 Operation in Clock Synchronous Mode	478	(2) Clock Description amended ... For details on SCI <sub>1</sub> clock source selection, ...
23.5 Usage Notes	488	(1) Relation between Writes to TDR1 and the TDRE Flag Description amended ... TDR1 to TSR. When the SCI <sub>1</sub> transfers data from TDR1 to TSR, ...
24.2.4 Serial Control Status Register 2 (SCSR2)	499	Bit 1—Abort Flag (ABT) Description amended ... while this bit is set to 1. Resume transfer after clearing to 0. Bit 0—Start Flag (STF) Description amended ... other than the SCSR2 and serial data buffer (32 bytes) are retained.
24.3.3 Data Transfer Operations	504	(1) SCI2 Initialization Description amended (2) The SCI2 pin is also used as a port. Switching of a port is performed on PMR <sub>3</sub> .
	505	Description amended ... While PMR30 of PMR3 is set to 1, transmission is ...
25.2.5 I <sup>2</sup> C Bus Control Register (ICCR)	521	Bit 7—I <sup>2</sup> C Bus Interface Enable (ICE) Description amended I <sup>2</sup> C Bus interface module enabled for transfer operations (pins SCL and SDA are driving the bus) ...
25.2.7 Serial/Timer Control Register (STCR)	533	Bit 5—I <sup>2</sup> C Controller Reset (IICRST) Description amended ... Therefore, be sure to clear the IICRST bit after setting it.
25.3.2 Master Transmit Operation	537	Description amended [11] ...When there is data to be transmitted, go to the step [9] to continue next transmission. ...



Item	Page	Revision (See Manual for Details)
25.3.3 Master Receive Operation Figure 25.7 Example of Master Receive Mode Operation Timing (MLS = ACKB = 0, WAIT = 1)	540	Figure 25.7 amended [4] IRIC clearance
25.3.8 Sample Flowcharts Figure 25.14 Flowchart for Master Transmit Mode (Example)	548	Figure 25.14 amended  <pre> graph TD     Start(( )) --&gt; Read[Read IRIC in ICCR]     Read --&gt; IRIC{IRIC = 1?}     IRIC -- No --&gt; Read     IRIC -- Yes --&gt; Write[Write transmit data in ICDR]     Write --&gt; Clear[Clear IRIC in ICCR]     Clear --&gt; End(( )) </pre>
25.4 Usage Notes	554	Description amended (1) ... then issue the instruction that generates the stop condition. Note that the SCL may briefly remain at a high level immediately after BBSY is cleared to 0.
	559 to 566	(10) Notes on WAIT Function (11) Notes on ICDR Reads and ICCR Access in Slave Transmit Mode (12) Notes on TRS Bit Setting in Slave Mode (13) Notes on Arbitration Lost in Master Mode (14) Notes on Interrupt Occurrence after ACKB Reception (15) Notes on TRS Bit Setting and ICDR Register Access Description added
28.2.3 Pin Configuration	610	Description amended ... P6n, P7n, P80 to P83, and PS1 to PS4 are general-purpose ports. ...
28.3.4 Register Descriptions	626	(5) Reference Period Mode Register 2 (RFM2) Description amended ... signal generators. Bits 6 to 1 are reserved. ...

Item	Page	Revision (See Manual for Details)																																				
28.11.2 Block Diagram Figure 28.38 Block Diagram of Digital Filter Circuit	713	Figure 28.38 amended 																																				
28.11.5 Register Descriptions	721	(6) Capstan System Digital Filter Control Register (CFIC) Bit figure amended <table border="1" data-bbox="443 523 1105 603"> <tr> <td>Bit :</td> <td>7</td> <td>6</td> <td>5</td> <td>4</td> <td>3</td> <td>2</td> <td>1</td> <td>0</td> </tr> <tr> <td></td> <td>—</td> <td>ⓄROV</td> <td>ⓄPHA</td> <td>ⓄZPON</td> <td>ⓄZSON</td> <td>ⓄSG2</td> <td>ⓄSG1</td> <td>ⓄSG0</td> </tr> <tr> <td>Initial value :</td> <td>1</td> <td>0</td> <td>0</td> <td>0</td> <td>0</td> <td>0</td> <td>0</td> <td>0</td> </tr> <tr> <td>R/W :</td> <td>—</td> <td>R/(W)*</td> <td>R/(W)</td> <td>R/W</td> <td>R/W</td> <td>R/W</td> <td>R/W</td> <td>R/W</td> </tr> </table>	Bit :	7	6	5	4	3	2	1	0		—	ⓄROV	ⓄPHA	ⓄZPON	ⓄZSON	ⓄSG2	ⓄSG1	ⓄSG0	Initial value :	1	0	0	0	0	0	0	0	R/W :	—	R/(W)*	R/(W)	R/W	R/W	R/W	R/W	R/W
Bit :	7	6	5	4	3	2	1	0																														
	—	ⓄROV	ⓄPHA	ⓄZPON	ⓄZSON	ⓄSG2	ⓄSG1	ⓄSG0																														
Initial value :	1	0	0	0	0	0	0	0																														
R/W :	—	R/(W)*	R/(W)	R/W	R/W	R/W	R/W	R/W																														
28.12.5 Additional V Pulse Signal	732	Description amended Additional V Pulses when Sync Signal Is Not Detected: ... depending on the HRTR and HPWR setting, with resultant discontinuity. ...																																				
28.13.5 Register Descriptions	740	(2) CTL Mode Register (CTLM) Description amended Bits 7 and 6: Record/Playback Mode Bits (ASM, REC/PB):																																				
	745	(6) REC-CTL Duty Data Register 4 (RCDR4) Description amended ... $RCDR4 = T4 \times \phi s/64$ $\phi s$ is the servo clock frequency ( $= f_{osc}/2$ ) in Hz, and T4 is ...																																				
	746	(7) REC-CTL Duty Data Register 5 (RCDR5) Description amended ... $RCDR5 = T5 \times \phi s/64$ $\phi s$ is the servo clock frequency ( $= f_{osc}/2$ ) in Hz, and T5 is ...																																				
	747	Bit 0—Duty I/O Register (DI/O) Description amended ... the VISS control circuit. In VISS record or rewrite mode ...																																				

Item	Page	Revision (See Manual for Details)																																			
28.13.6 Operation Figure 28.50 Example of CTLM Switchover Timing (When Phase Control Is Performed by REF30P and DVCFG2 in REC Mode)	751	Figure 28.50 amended (Before) PDCR3 → (After) PCDR3																																			
Figure 28.51 Example of CTLM Switchover Timing (When Phase Control Is Performed by CREF and DVCFG2 in REC Mode)	752	Figure 28.51 amended Ta is the interval calculated from RCDR3. ...																																			
28.18.9 CTL Output Section Table 28.21 REC-CTL Duty Register and CTL Outputs	762	Table 28.21 amended (Before) 65.5 ±0.5% → (After) 62.5 ±0.5%																																			
28.15.6 Noise Detection	790	(1) Example of Setting Description amended ∴ HPWR3 - 0 = H'B																																			
29.2.7 Flash Memory Characteristics Table 29.12 Flash Memory Characteristics (Preliminary)	824	Table 29.12 amended																																			
		<table border="1"> <thead> <tr> <th>Item</th> <th>Symbol</th> <th>Min</th> <th>Typ</th> <th>Max</th> <th>Unit</th> <th>Test Conditions</th> </tr> </thead> <tbody> <tr> <td>Erasing time<sup>a1)~3)5)</sup></td> <td>t<sub>E</sub></td> <td></td> <td>100</td> <td>1200</td> <td>ms/block</td> <td></td> </tr> <tr> <td>Reprogramming count</td> <td>N<sub>WEC</sub></td> <td>100<sub>87)</sub></td> <td>10000<sub>88)</sub></td> <td>—</td> <td>Times</td> <td></td> </tr> <tr> <td>Data retention time<sup>a9)</sup></td> <td>t<sub>DRP</sub></td> <td>10</td> <td>—</td> <td>—</td> <td>Years</td> <td></td> </tr> <tr> <td>At Programming</td> <td>Wait time after SWE-bit setting<sup>a1)</sup> x</td> <td>10</td> <td>—</td> <td>—</td> <td>µs</td> <td></td> </tr> </tbody> </table>	Item	Symbol	Min	Typ	Max	Unit	Test Conditions	Erasing time <sup>a1)~3)5)</sup>	t <sub>E</sub>		100	1200	ms/block		Reprogramming count	N <sub>WEC</sub>	100 <sub>87)</sub>	10000 <sub>88)</sub>	—	Times		Data retention time <sup>a9)</sup>	t <sub>DRP</sub>	10	—	—	Years		At Programming	Wait time after SWE-bit setting <sup>a1)</sup> x	10	—	—	µs	
Item	Symbol	Min	Typ	Max	Unit	Test Conditions																															
Erasing time <sup>a1)~3)5)</sup>	t <sub>E</sub>		100	1200	ms/block																																
Reprogramming count	N <sub>WEC</sub>	100 <sub>87)</sub>	10000 <sub>88)</sub>	—	Times																																
Data retention time <sup>a9)</sup>	t <sub>DRP</sub>	10	—	—	Years																																
At Programming	Wait time after SWE-bit setting <sup>a1)</sup> x	10	—	—	µs																																
	825	Notes 7 to 9 added  Notes: 7. Minimum number of times for which all characteristics are guaranteed after rewriting (Guarantee range is 1 to minimum value). 8. Reference value for 25°C (as a guideline, rewriting should normally function up to this value). 9. Data retention characteristic when rewriting is performed within the specification range, including the minimum value.																																			

A.1 Instructions 856 (7) System Control Instructions in table A.1 amended

Table A.1 List of Instruction Set

Mnemonic		No of Execution States *1
Advanced Mode		
TRAPA	TRAPA #xxx:2	8 [9]
RTE	RTE	5 [9]
SLEEP	SLEEP	2
LDC	LDC #xx:8,CCR	1
	LDC #xx:8,EXR	2
	LDC R <sub>s</sub> ,CCR	1
	LDC R <sub>s</sub> ,EXR	1
	LDC @ER <sub>s</sub> ,CCR	3
	LDC @ER <sub>s</sub> ,EXR	3
	LDC @(d:16,ER <sub>s</sub> ),CCR	4
	LDC @(d:16,ER <sub>s</sub> ),EXR	4
	LDC @(d:32,ER <sub>s</sub> ),CCR	6
	LDC @(d:32,ER <sub>s</sub> ),EXR	6
	LDC @ER <sub>s</sub> ,CCR	4
	LDC @ER <sub>s</sub> ,EXR	4
	LDC @aa:16,CCR	4
LDC @aa:16,EXR	4	
LDC @aa:32,CCR	5	
LDC @aa:32,EXR	5	
STC	STC CCR,R <sub>d</sub>	1
	STC EXR,R <sub>d</sub>	1
	STC CCR,@ER <sub>d</sub>	3
	STC EXR,@ER <sub>d</sub>	3
	STC CCR,@(d:16,ER <sub>d</sub> )	4
	STC EXR,@(d:16,ER <sub>d</sub> )	4
	STC CCR,@(d:32,ER <sub>d</sub> )	6
	STC EXR,@(d:32,ER <sub>d</sub> )	6
	STC CCR,@-ER <sub>d</sub>	4
	STC EXR,@-ER <sub>d</sub>	4
	STC CCR,@aa:16	4
	STC EXR,@aa:16	4
	STC CCR,@aa:32	5
STC EXR,@aa:32	5	
ANDC	ANDC #xx:8,CCR	1
	ANDC #xx:8,EXR	2
ORC	ORC #xx:8,CCR	1
	ORC #xx:8,EXR	2
XORC	XORC #xx:8,CCR	1
	XORC #xx:8,EXR	2
NOP	NOP	1

A.4 Number of Execution States 872 Description amended  
 ... for each instruction of the H8S/2000 CPU. Table A.5 ...

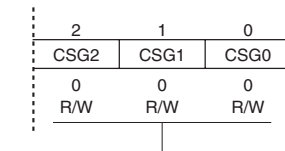
Table A.4 Number of States Required for Each Execution Status (Cycle) 873 Table A.4 amended

Execution Status (Cycle)	Target of Access		
	On-Chip Memory	On-Chip Supporting Module	
		8-Bit Bus	16-Bit Bus
Byte data access S <sub>L</sub>		2	2
Word data access S <sub>M</sub>		4	2
Internal operation S <sub>N</sub>	1	1	1

A.6 Change of Condition Codes 902 Table A.7 amended  
 (Before) C=D<sub>0</sub> (In case of 1 bit), C=D<sub>0-1</sub> (In case of 2 bits) →  
 (After) C=D<sub>0</sub> (In case of 1 bit), C=D<sub>1</sub> (In case of 2 bits)

B.2 Function List                      918                      H'D029: CFIC: Digital Filter

Figure amended



Capstan system gain control bit

CSG2	CSG1	CSG0	Description
0	0	0	×1
		1	×2
	1	0	×4
		1	×8
1	0	0	×16
		1	(×32)*
	1	0	(×64)*
		1	Invalid (do not set)

Note: \* Setting optional

919                      H'D031: DFPR: Drum Error Detector  
 H'D033: DFER: Drum Error Detector  
 Subheading deleted

919                      H'D032: DFER: Drum Error Detector  
 Note \* added  
 Note: \* Note that only detected error data can be read.

920                      H'D035: DFRUDR: Drum Error Detector  
 H'D037: DFRLDR: Drum Error Detector  
 Subheading deleted

927                      H'D060: HSM1: HSW Timing Generator  
 Figure amended

-----  
 ↓  
 FIFO1 overwrite flag

0	Normal operation
1	Data is written to FIFO2 while it is full. Write 0 to clear the flag.

941                      Table amended  
 Video FF signal turns counter set ON

B.2 Function List 954 H'D0E2: SCR2: 32-byte Buffer SCI2

Figure amended

Transfer clock select bits				SCK2 pin	Clock source	Prescaler frequency division rate	Transfer clock frequency	
CKS2	CKS1	CKS0	$\phi = 10 \text{ MHz}$				$\phi = 5 \text{ MHz}$	
0	0	0	SCK2 output	Sprescaler S	$\phi/256$	25.6 $\mu\text{s}$	51.2 $\mu\text{s}$	
0	0	1			$\phi/64$	6.4 $\mu\text{s}$	12.8 $\mu\text{s}$	
0	1	0			$\phi/32$	3.2 $\mu\text{s}$	6.4 $\mu\text{s}$	
0	1	1			$\phi/16$	1.6 $\mu\text{s}$	3.2 $\mu\text{s}$	
1	0	0			$\phi/8$	0.8 $\mu\text{s}$	1.6 $\mu\text{s}$	
1	0	1			$\phi/4$	0.4 $\mu\text{s}$	0.8 $\mu\text{s}$	
1	1	0			$\phi/2$	—	—	0.4 $\mu\text{s}$
1	1	1	SCK2 input	External clock	—	—	—	

Transfer data interval select bits

GAP1	GAP0	Transfer data interval
0	0	No interval
0	1	8-clock interval
1	0	24-clock interval
1	1	56-clock interval

956 H'D100: ITER: Timer X1

Figure amended

Output compare interrupt enable bit

0	OFV interrupt request (FOVI) is disabled
1	OFV interrupt request (FOVI) is enabled

962 H'D100: TMB: Timer B

Figure amended

Clock select bit

Count at rising/falling edge of external event (TMBI)\*

984 H'D14C: SSR1: SCI1

Figure amended

Parity error

(Before) (even or odd) specified by the O/E bit in SMR1\*<sup>2</sup> →  
 (After) (even or odd) specified by the O/E bit in SMR1\*<sup>2</sup>

986 H'D158: ICCR: IIC Bus Interface

Figure amended

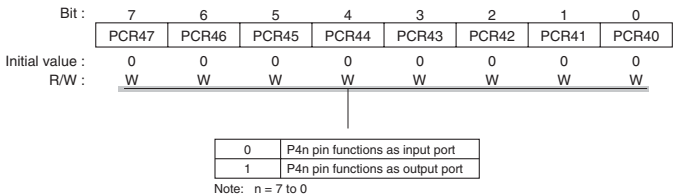
I<sup>2</sup>C bus interface enable

I<sup>2</sup>C bus interface module enabled for transfer operation (pins SCL and SDA are driving the bus)

**Item**                      **Page**                      **Revision (See Manual for Details)**

B.2 Function List                      1000                      H'FFD4: PCR4: I/O Port

Figure amended



1002                      H'FFDC: PMR5: I/O Port

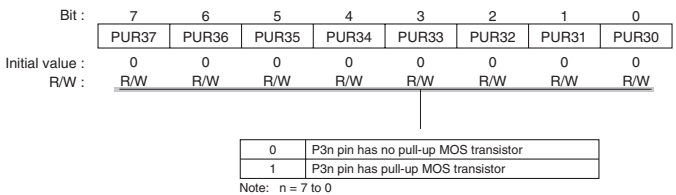
Figure amended

P52/TRIG pin function select bit

P52/TMBI pin functions as TMBI input port

1004                      H'FFE3: PUR3: I/O Port

Figure amended



1010                      Table amended

(Before) IRQ0EG2 → (After) IRQ0EG0

C.1 Pin Circuit Diagrams

1019 to                      Circuit diagram description amended

1024

PUR1n	PCR1n	PUR17	PCR17	PUR20	PCR20
PUR21	PCR21	PUR22	PCR22	PUR2n	PCR2n
PUR26	PCR26	PUR25	PCR25	PUR27	PCR27
PUR30	PCR30	PUR3n	PCR3n		

1024                      Circuit diagram description amended

(Before) OUR → (After) OUT:

1025                      Pin name description amended

P42/FTIB

P46/FTOB

G. External Dimensions

1037                      Figure G.1 replaced

Figure G.1 External Dimensions (FP-112)

All trademarks and registered trademarks are the property of their respective owners.

Rev.3.00 Jan. 10, 2007 page xvi of xxxvi  
REJ09B0328-0300





# Contents

Section 1	Overview .....	1
1.1	Overview .....	1
1.2	Internal Block Diagram.....	6
1.3	Pin Arrangement and Functions.....	7
1.3.1	Pin Arrangement .....	7
1.3.2	Pin Functions .....	8
1.4	Differences between H8S/2194C Group and H8S/2194 Group.....	14
Section 2	CPU .....	15
2.1	Overview .....	15
2.1.1	Features .....	15
2.1.2	Differences between H8S/2600 CPU and H8S/2000 CPU .....	16
2.1.3	Differences from H8/300 CPU.....	17
2.1.4	Differences from H8/300H CPU.....	17
2.2	CPU Operating Modes .....	18
2.2.1	Normal Mode.....	18
2.2.2	Advanced Mode.....	20
2.3	Address Space .....	23
2.4	Register Configuration .....	24
2.4.1	Overview.....	24
2.4.2	General Registers .....	25
2.4.3	Control Registers .....	26
2.4.4	Initial Register Values.....	28
2.5	Data Formats .....	28
2.5.1	General Register Data Formats .....	29
2.5.2	Memory Data Formats .....	31
2.6	Instruction Set .....	32
2.6.1	Overview.....	32
2.6.2	Instructions and Addressing Modes.....	34
2.6.3	Table of Instructions Classified by Function .....	35
2.6.4	Basic Instruction Formats .....	45
2.6.5	Notes on Use of Bit-Manipulation Instructions .....	46
2.7	Addressing Modes and Effective Address Calculation .....	46
2.7.1	Addressing Mode.....	46
2.7.2	Effective Address Calculation.....	49
2.8	Processing States.....	53
2.8.1	Overview.....	53

2.8.2	Reset State .....	54
2.8.3	Exception-Handling State .....	55
2.8.4	Program Execution State.....	56
2.8.5	Power-Down State .....	57
2.9	Basic Timing.....	58
2.9.1	Overview.....	58
2.9.2	On-Chip Memory (ROM, RAM).....	58
2.9.3	On-Chip Supporting Module Access Timing .....	59
2.10	Usage Note.....	59
<b>Section 3 MCU Operating Modes .....</b>		<b>61</b>
3.1	Overview.....	61
3.1.1	Operating Mode Selection .....	61
3.1.2	Register Configuration.....	61
3.2	Register Descriptions .....	62
3.2.1	Mode Control Register (MDCR) .....	62
3.2.2	System Control Register (SYSCR).....	62
3.3	Operating Mode Descriptions .....	63
3.3.1	Mode 1 .....	63
3.4	Address Map.....	64
<b>Section 4 Power-Down State.....</b>		<b>69</b>
4.1	Overview.....	69
4.1.1	Register Configuration.....	73
4.2	Register Descriptions .....	74
4.2.1	Standby Control Register (SBYCR) .....	74
4.2.2	Low-Power Control Register (LPWRCR) .....	76
4.2.3	Timer Register A (TMA).....	78
4.2.4	Module Stop Control Register (MSTPCR).....	79
4.3	Medium-Speed Mode.....	80
4.4	Sleep Mode .....	81
4.4.1	Sleep Mode .....	81
4.4.2	Clearing Sleep Mode.....	81
4.5	Module Stop Mode .....	82
4.5.1	Module Stop Mode .....	82
4.6	Standby Mode .....	83
4.6.1	Standby Mode.....	83
4.6.2	Clearing Standby Mode .....	83
4.6.3	Setting Oscillation Settling Time after Clearing Standby Mode.....	83
4.7	Watch Mode.....	85

4.7.1	Watch Mode.....	85
4.7.2	Clearing Watch Mode .....	85
4.8	Subsleep Mode.....	86
4.8.1	Subsleep Mode.....	86
4.8.2	Clearing Subsleep Mode .....	86
4.9	Subactive Mode.....	87
4.9.1	Subactive Mode .....	87
4.9.2	Clearing Subactive Mode.....	87
4.10	Direct Transition .....	88
4.10.1	Overview of Direct Transition .....	88
 Section 5 Exception Handling .....		 89
5.1	Overview.....	89
5.1.1	Exception Handling Types and Priority.....	89
5.1.2	Exception Handling Operation.....	90
5.1.3	Exception Sources and Vector Table .....	90
5.2	Reset.....	92
5.2.1	Overview.....	92
5.2.2	Reset Sequence .....	92
5.2.3	Interrupts after Reset.....	93
5.3	Interrupts .....	94
5.4	Trap Instruction.....	95
5.5	Stack Status after Exception Handling.....	96
5.6	Notes on Use of the Stack .....	97
 Section 6 Interrupt Controller .....		 99
6.1	Overview.....	99
6.1.1	Features.....	99
6.1.2	Block Diagram.....	100
6.1.3	Pin Configuration.....	101
6.1.4	Register Configuration.....	101
6.2	Register Descriptions .....	102
6.2.1	System Control Register (SYSCR).....	102
6.2.2	Interrupt Control Registers A to D (ICRA to ICRD) .....	103
6.2.3	IRQ Enable Register (IENR) .....	104
6.2.4	IRQ Edge Select Registers (IEGR).....	104
6.2.5	IRQ Status Register (IRQR) .....	105
6.2.6	Port Mode Register (PMR1) .....	106
6.3	Interrupt Sources .....	108
6.3.1	External Interrupts .....	108

6.3.2	Internal Interrupts .....	110
6.3.3	Interrupt Exception Vector Table .....	110
6.4	Interrupt Operation.....	113
6.4.1	Interrupt Control Modes and Interrupt Operation.....	113
6.4.2	Interrupt Control Mode 0.....	115
6.4.3	Interrupt Control Mode 1 .....	117
6.4.4	Interrupt Exception Handling Sequence .....	120
6.4.5	Interrupt Response Times .....	121
6.5	Usage Notes .....	122
6.5.1	Contention between Interrupt Generation and Disabling.....	122
6.5.2	Instructions That Disable Interrupts.....	123
6.5.3	Interrupts during Execution of EEPMOV Instruction.....	123
6.5.4	When NMI Is Disabled .....	123
Section 7 ROM (H8S/2194 Group).....		125
7.1	Overview.....	125
7.1.1	Block Diagram.....	125
7.2	Overview of Flash Memory .....	126
7.2.1	Features.....	126
7.2.2	Block Diagram.....	127
7.2.3	Flash Memory Operating Modes .....	128
7.2.4	Pin Configuration.....	132
7.2.5	Register Configuration.....	132
7.3	Flash Memory Register Descriptions.....	133
7.3.1	Flash Memory Control Register 1 (FLMCR1).....	133
7.3.2	Flash Memory Control Register 2 (FLMCR2).....	136
7.3.3	Erase Block Registers 1 and 2 (EBR1, EBR2) .....	138
7.3.4	Serial/Timer Control Register (STCR) .....	139
7.4	On-Board Programming Modes.....	140
7.4.1	Boot Mode .....	141
7.4.2	User Program Mode.....	146
7.5	Programming/Erasing Flash Memory .....	147
7.5.1	Program Mode .....	147
7.5.2	Program-Verify Mode.....	148
7.5.3	Erase Mode .....	150
7.5.4	Erase-Verify Mode .....	150
7.6	Flash Memory Protection.....	152
7.6.1	Hardware Protection .....	152
7.6.2	Software Protection.....	153
7.6.3	Error Protection.....	153

7.7	Interrupt Handling when Programming/Erasing Flash Memory .....	155
7.8	Flash Memory Programmer Mode .....	156
7.8.1	Programmer Mode Setting .....	156
7.8.2	Socket Adapters and Memory Map.....	156
7.8.3	Programmer Mode Operation .....	157
7.8.4	Memory Read Mode .....	158
7.8.5	Auto-Program Mode .....	161
7.8.6	Auto-Erase Mode .....	163
7.8.7	Status Read Mode .....	164
7.8.8	Status Polling .....	166
7.8.9	Programmer Mode Transition Time.....	166
7.8.10	Notes On Memory Programming.....	167
7.9	Flash Memory Programming and Erasing Precautions .....	168
7.10	Note on Switching from F-ZTAT Version to Mask ROM Version .....	170
<b>Section 8 ROM (H8S/2194C Group).....</b>		<b>171</b>
8.1	Overview .....	171
8.1.1	Block Diagram .....	171
8.2	Overview of Flash Memory .....	172
8.2.1	Features .....	172
8.2.2	Block Diagram .....	173
8.2.3	Flash Memory Operating Modes .....	174
8.2.4	Pin Configuration.....	178
8.2.5	Register Configuration.....	178
8.3	Flash Memory Register Descriptions.....	179
8.3.1	Flash Memory Control Register 1 (FLMCR1).....	179
8.3.2	Flash Memory Control Register 2 (FLMCR2).....	183
8.3.3	Erase Block Registers 1 (EBR1).....	186
8.3.4	Erase Block Registers 2 (EBR2).....	186
8.3.5	Serial/Timer Control Register (STCR) .....	187
8.4	On-Board Programming Modes.....	188
8.4.1	Boot Mode .....	189
8.4.2	User Program Mode.....	193
8.5	Programming/Erasing Flash Memory .....	195
8.5.1	Program Mode (n = 1 for Addresses H'00000 to H'1FFFF and n = 2 for Addresses H'20000 to H'3FFFF).....	195
8.5.2	Program-Verify Mode (n = 1 for Addresses H'00000 to H'1FFFF and n = 2 for Addresses H'20000 to H'3FFFF) .....	196
8.5.3	Erase Mode (n = 1 for Addresses H'00000 to H'1FFFF and n = 2 for Addresses H'20000 to H'3FFFF) .....	198

8.5.4	Erase-Verify Mode (n = 1 for Addresses H'00000 to H'1FFFF and n = 2 for Addresses H'20000 to H'3FFFF) .....	198
8.6	Flash Memory Protection.....	200
8.6.1	Hardware Protection .....	200
8.6.2	Software Protection.....	201
8.6.3	Error Protection.....	202
8.7	Interrupt Handling when Programming/Erasing Flash Memory .....	204
8.8	Flash Memory Programmer Mode .....	205
8.8.1	Programmer Mode Setting .....	205
8.8.2	Socket Adapters and Memory Map .....	205
8.8.3	Programmer Mode Operation .....	206
8.8.4	Memory Read Mode .....	207
8.8.5	Auto-Program Mode .....	211
8.8.6	Auto-Erase Mode.....	213
8.8.7	Status Read Mode .....	214
8.8.8	Status Polling .....	216
8.8.9	Programmer Mode Transition Time .....	217
8.8.10	Notes On Memory Programming.....	217
8.9	Flash Memory Programming and Erasing Precautions .....	218
8.10	Note on Switching from F-ZTAT Version to Mask ROM Version .....	220
<b>Section 9 RAM.....</b>		<b>221</b>
9.1	Overview.....	221
9.1.1	Block Diagram.....	221
<b>Section 10 Clock Pulse Generator .....</b>		<b>223</b>
10.1	Overview.....	223
10.1.1	Block Diagram.....	223
10.1.2	Register Configuration.....	223
10.2	Register Descriptions .....	224
10.2.1	Standby Control Register (SBYCR) .....	224
10.2.2	Low-Power Control Register (LPWRCR) .....	225
10.3	Oscillator.....	226
10.3.1	Connecting a Crystal Resonator.....	226
10.3.2	External Clock Input.....	228
10.4	Duty Adjustment Circuit.....	230
10.5	Medium-Speed Clock Divider .....	230
10.6	Bus Master Clock Selection Circuit.....	230
10.7	Subclock Oscillator Circuit.....	231
10.7.1	Connecting 32.768 kHz Crystal Resonator.....	231

10.7.2	External Clock Input .....	232
10.7.3	When Subclock Is Not Needed .....	232
10.8	Subclock Waveform Shaping Circuit.....	233
10.9	Notes on the Resonator .....	233
Section 11	I/O Port.....	235
11.1	Overview.....	235
11.1.1	Port Functions .....	235
11.1.2	Port Input .....	235
11.1.3	MOS Pull-Up Transistors.....	237
11.2	Port 0.....	238
11.2.1	Overview.....	238
11.2.2	Register Configuration.....	238
11.2.3	Pin Functions .....	240
11.2.4	Pin States.....	240
11.3	Port 1.....	241
11.3.1	Overview.....	241
11.3.2	Register Configuration.....	241
11.3.3	Pin Functions .....	245
11.3.4	Pin States.....	246
11.4	Port 2.....	247
11.4.1	Overview.....	247
11.4.2	Register Configuration.....	247
11.4.3	Pin Functions .....	251
11.4.4	Pin States.....	253
11.5	Port 3.....	254
11.5.1	Overview.....	254
11.5.2	Register Configuration.....	254
11.5.3	Pin Functions .....	258
11.5.4	Pin States.....	260
11.6	Port 4.....	261
11.6.1	Overview.....	261
11.6.2	Register Configuration.....	261
11.6.3	Pin Functions .....	263
11.6.4	Pin States.....	266
11.7	Port 5.....	267
11.7.1	Overview.....	267
11.7.2	Register Configuration.....	267
11.7.3	Pin Functions .....	270
11.7.4	Pin States.....	271

11.8	Port 6.....	272
11.8.1	Overview.....	272
11.8.2	Register Configuration.....	273
11.8.3	Pin Functions .....	276
11.8.4	Operation .....	277
11.8.5	Pin States .....	278
11.9	Port 7.....	279
11.9.1	Overview.....	279
11.9.2	Register Configuration.....	279
11.9.3	Pin Functions .....	281
11.9.4	Pin States .....	281
11.10	Port 8.....	282
11.10.1	Overview.....	282
11.10.2	Register Configuration.....	282
11.10.3	Pin Functions .....	285
11.10.4	Pin States .....	287
Section 12 Timer A.....		289
12.1	Overview.....	289
12.1.1	Features.....	289
12.1.2	Block Diagram.....	290
12.1.3	Register Configuration.....	290
12.2	Descriptions of Respective Registers.....	291
12.2.1	Timer Mode Register A (TMA).....	291
12.2.2	Timer Counter A (TCA) .....	293
12.2.3	Module Stop Control Register (MSTPCR).....	293
12.3	Operation .....	294
12.3.1	Operation as the Interval Timer .....	294
12.3.2	Operation of the Timer for Clocks.....	294
12.3.3	Initializing the Counts.....	294
Section 13 Timer B .....		295
13.1	Overview.....	295
13.1.1	Features.....	295
13.1.2	Block Diagram.....	295
13.1.3	Pin Configuration.....	296
13.1.4	Register Configuration.....	296
13.2	Descriptions of Respective Registers.....	297
13.2.1	Timer Mode Register B (TMB) .....	297
13.2.2	Timer Counter B (TCB).....	299



13.2.3	Timer Load Register B (TLB) .....	299
13.2.4	Port Mode Register 5 (PMR5) .....	299
13.2.5	Module Stop Control Register (MSTPCR) .....	300
13.3	Operation.....	301
13.3.1	Operation as the Interval Timer .....	301
13.3.2	Operation as the Auto Reload Timer .....	301
13.3.3	Event Counter .....	301
<b>Section 14 Timer J.....</b>		<b>303</b>
14.1	Overview.....	303
14.1.1	Features.....	303
14.1.2	Block Diagram.....	303
14.1.3	Pin Configuration.....	305
14.1.4	Register Configuration.....	305
14.2	Descriptions of Respective Registers.....	306
14.2.1	Timer Mode Register J (TMJ) .....	306
14.2.2	Timer J Control Register (TMJC).....	309
14.2.3	Timer J Status Register (TMJS).....	311
14.2.4	Timer Counter J (TCJ).....	312
14.2.5	Timer Counter K (TCK) .....	313
14.2.6	Timer Load Register J (TLJ).....	313
14.2.7	Timer Load Register K (TLK).....	314
14.2.8	Module Stop Control Register (MSTPCR).....	314
14.3	Operation.....	315
14.3.1	8-Bit Reload Timer (TMJ-1).....	315
14.3.2	8-Bit Reload Timer (TMJ-2).....	315
14.3.3	Remote Controlled Data Transmission .....	316
<b>Section 15 Timer L.....</b>		<b>321</b>
15.1	Overview.....	321
15.1.1	Features.....	321
15.1.2	Block Diagram.....	322
15.1.3	Register Configuration.....	323
15.2	Descriptions of Respective Registers.....	324
15.2.1	Timer L Mode Register (LMR).....	324
15.2.2	Linear Time Counter (LTC).....	326
15.2.3	Reload/Compare Match Register (RCR).....	326
15.2.4	Module Stop Control Register (MSTPCR).....	326
15.3	Operation.....	327
15.3.1	Compare Match Clear Operation .....	327

Section 16	Timer R .....	329
16.1	Overview.....	329
16.1.1	Features.....	329
16.1.2	Block Diagram.....	329
16.1.3	Pin Configuration.....	331
16.1.4	Register Configuration.....	331
16.2	Descriptions of Respective Registers.....	332
16.2.1	Timer R Mode Register 1 (TMRM1).....	332
16.2.2	Timer R Mode Register 2 (TMRM2).....	334
16.2.3	Timer R Control/Status Register (TMRCs).....	337
16.2.4	Timer R Capture Register 1 (TMRCp1) .....	339
16.2.5	Timer R Capture Register 2 (TMRCp2) .....	340
16.2.6	Timer R Load Register 1 (TMRL1) .....	340
16.2.7	Timer R Load Register 2 (TMRL2) .....	341
16.2.8	Timer R Load Register 3 (TMRL3) .....	341
16.2.9	Module Stop Control Register (MSTPCR) .....	342
16.3	Operation .....	343
16.3.1	Reload Timer Counter Equipped with Capturing Function TMRU-1.....	343
16.3.2	Reload Timer Counter Equipped with Capturing Function TMRU-2.....	344
16.3.3	Reload Counter Timer TMRU-3.....	344
16.3.4	Mode Identification.....	345
16.3.5	Reeling Controls .....	345
16.3.6	Acceleration and Braking Processes of the Capstan Motor .....	345
16.3.7	Slow Tracking Mono-Multi Function .....	346
16.4	Interrupt Cause.....	348
16.5	Exemplary Settings for Respective Functions .....	349
16.5.1	Mode Identification.....	349
16.5.2	Reeling Controls .....	350
16.5.3	Slow Tracking Mono-Multi Function .....	350
16.5.4	Acceleration and Braking Processes of the Capstan Motor .....	351
Section 17	Timer X1 .....	353
17.1	Overview.....	353
17.1.1	Features.....	353
17.1.2	Block Diagram.....	353
17.1.3	Pin Configuration.....	355
17.1.4	Register Configuration.....	356
17.2	Descriptions of Respective Registers.....	357
17.2.1	Free Running Counter (FRC).....	357
17.2.2	Output Comparing Register A and B (OCRA and OCRB).....	357

17.2.3	Input Capture Register A Through D (ICRA Through ICRD).....	358
17.2.4	Timer Interrupt Enabling Register (TIER).....	360
17.2.5	Timer Control/Status Register X (TCSRX) .....	362
17.2.6	Timer Control Register X (TCRX) .....	366
17.2.7	Timer Output Comparing Control Register (TOCR) .....	368
17.2.8	Module Stop Control Register (MSTPCR) .....	371
17.3	Operation.....	372
17.3.1	Operation of the Timer X1 .....	372
17.3.2	Counting Timing of the FRC .....	373
17.3.3	Output Comparing Signal Outputting Timing .....	374
17.3.4	FRC Clearing Timing .....	374
17.3.5	Input Capture Signal Inputting Timing .....	375
17.3.6	Input Capture Flag (ICFA through ICFD) Setting Up Timing.....	376
17.3.7	Output Comparing Flag (OCFA and OCFB) Setting Up Timing .....	377
17.3.8	Overflow Flag (CVF) Setting Up Timing.....	377
17.4	Operation Mode of the Timer X1.....	378
17.5	Interrupt Causes .....	378
17.6	Exemplary Uses of the Timer X1.....	379
17.7	Precautions when Using the Timer X1 .....	380
17.7.1	Competition between Writing and Clearing with the FRC .....	380
17.7.2	Competition between Writing and Counting Up with the FRC .....	381
17.7.3	Competition between Writing and Comparing Match with the OCR .....	382
17.7.4	Changing over the Internal Clocks and Counter Operations.....	383
<b>Section 18 Watchdog Timer (WDT).....</b>		<b>385</b>
18.1	Overview.....	385
18.1.1	Features.....	385
18.1.2	Block Diagram.....	386
18.1.3	Register Configuration.....	387
18.2	Register Descriptions .....	388
18.2.1	Watchdog Timer Counter (WTCNT).....	388
18.2.2	Watchdog Timer Control/Status Register (WTCSR).....	388
18.2.3	System Control Register (SYSCR).....	391
18.2.4	Notes on Register Access.....	391
18.3	Operation.....	393
18.3.1	Watchdog Timer Operation .....	393
18.3.2	Interval Timer Operation .....	394
18.3.3	Timing of Setting of Overflow Flag (OVF).....	395
18.4	Interrupts .....	396
18.5	Usage Notes .....	396

18.5.1	Contention between Watchdog Timer Counter (WTCNT) Write and Increment	396
18.5.2	Changing Value of CKS2 to CKS0.....	397
18.5.3	Switching between Watchdog Timer Mode and Interval Timer Mode.....	397
<b>Section 19</b>	<b>8-Bit PWM.....</b>	<b>399</b>
19.1	Overview.....	399
19.1.1	Features.....	399
19.1.2	Block Diagram.....	399
19.1.3	Pin Configuration.....	400
19.1.4	Register Configuration.....	400
19.2	Register Descriptions .....	401
19.2.1	Bit PWM Data Registers 0, 1, 2, and 3 (PWR0, PWR1, PWR2, PWR3) .....	401
19.2.2	8-Bit PWM Control Register (PW8CR) .....	402
19.2.3	Port Mode Register 3 (PMR3) .....	402
19.2.4	Module Stop Control Register (MSTPCR) .....	403
19.3	8-Bit PWM Operation.....	404
<b>Section 20</b>	<b>12-Bit PWM .....</b>	<b>405</b>
20.1	Overview.....	405
20.1.1	Features.....	405
20.1.2	Block Diagram.....	406
20.1.3	Pin Configuration.....	407
20.1.4	Register Configuration.....	407
20.2	Register Descriptions .....	408
20.2.1	12-Bit PWM Control Registers (CPWCR, DPWCR) .....	408
20.2.2	12-Bit PWM Data Registers (CPWDR, DPWDR) .....	410
20.2.3	Module Stop Control Register (MSTPCR) .....	411
20.3	Operation .....	412
20.3.1	Output Waveform .....	412
<b>Section 21</b>	<b>14-Bit PWM .....</b>	<b>415</b>
21.1	Overview.....	415
21.1.1	Features.....	415
21.1.2	Block Diagram.....	416
21.1.3	Pin Configuration.....	416
21.1.4	Register Configuration.....	417
21.2	Register Descriptions .....	418
21.2.1	PWM Control Register (PWCR).....	418
21.2.2	PWM Data Registers U and L (PWDRU, PWDRL).....	419
21.2.3	Module Stop Control Register (MSTPCR) .....	420

21.3	14-Bit PWM Operation.....	421
Section 22	Prescalar Unit.....	423
22.1	Overview.....	423
22.1.1	Features.....	423
22.1.2	Block Diagram.....	424
22.1.3	Pin Configuration.....	425
22.1.4	Register Configuration.....	425
22.2	Registers.....	426
22.2.1	Input Capture Register 1 (ICR1).....	426
22.2.2	Prescalar Unit Control/Status Register (PCSR).....	426
22.2.3	Port Mode Register 1 (PMR1).....	428
22.3	Noise Cancel Circuit.....	429
22.4	Operation.....	429
22.4.1	Prescalar S (PSS).....	429
22.4.2	Prescalar W (PSW).....	430
22.4.3	Stable Oscillation Wait Time Count.....	430
22.4.4	8-Bit PWM.....	431
22.4.5	8-Bit Input Capture Using $\overline{IC}$ Pin.....	431
22.4.6	Frequency Division Clock Output.....	431
Section 23	Serial Communication Interface 1 (SCI1).....	433
23.1	Overview.....	433
23.1.1	Features.....	433
23.1.2	Block Diagram.....	435
23.1.3	Pin Configuration.....	436
23.1.4	Register Configuration.....	436
23.2	Register Descriptions.....	437
23.2.1	Receive Shift Register (RSR).....	437
23.2.2	Receive Data Register (RDR1).....	437
23.2.3	Transmit Shift Register (TSR).....	438
23.2.4	Transmit Data Register (TDR1).....	438
23.2.5	Serial Mode Register (SMR1).....	439
23.2.6	Serial Control Register (SCR1).....	442
23.2.7	Serial Status Register (SSR1).....	445
23.2.8	Bit Rate Register (BRR1).....	449
23.2.9	Serial Interface Mode Register (SCMR1).....	456
23.2.10	Module Stop Control Register (MSTPCR).....	457
23.3	Operation.....	458
23.3.1	Overview.....	458

23.3.2	Operation in Asynchronous Mode .....	460
23.3.3	Multiprocessor Communication Function.....	470
23.3.4	Operation in Clock Synchronous Mode.....	478
23.4	SCI1 Interrupts.....	487
23.5	Usage Notes .....	488
<b>Section 24 Serial Communication Interface 2 (SCI2) .....</b>		<b>491</b>
24.1	Overview.....	491
24.1.1	Features.....	491
24.1.2	Block Diagram.....	492
24.1.3	Pin Configuration.....	493
24.1.4	Register Configuration.....	493
24.2	Register Descriptions .....	494
24.2.1	Starting Address Register (STAR).....	494
24.2.2	Ending Address Register (EDAR) .....	494
24.2.3	Serial Control Register 2 (SCR2).....	495
24.2.4	Serial Control Status Register 2 (SCSR2).....	497
24.2.5	Module Stop Control Register (MSTPCR).....	500
24.3	Operation .....	501
24.3.1	Clock.....	501
24.3.2	Data Transfer Format.....	501
24.3.3	Data Transfer Operations.....	504
24.4	Interrupt Sources.....	508
<b>Section 25 I<sup>2</sup>C Bus Interface (IIC).....</b>		<b>509</b>
25.1	Overview.....	509
25.1.1	Features.....	509
25.1.2	Block Diagram.....	510
25.1.3	Pin Configuration.....	511
25.1.4	Register Configuration.....	512
25.2	Register Descriptions .....	513
25.2.1	I <sup>2</sup> C Bus Data Register (ICDR) .....	513
25.2.2	Slave Address Register (SAR).....	515
25.2.3	Second Slave Address Register (SARX) .....	516
25.2.4	I <sup>2</sup> C Bus Mode Register (ICMR).....	517
25.2.5	I <sup>2</sup> C Bus Control Register (ICCR).....	521
25.2.6	I <sup>2</sup> C Bus Status Register (ICSR).....	527
25.2.7	Serial/Timer Control Register (STCR) .....	532
25.2.8	Module Stop Control Register (MSTPCR).....	533
25.3	Operation .....	535

25.3.1	I <sup>2</sup> C Bus Data Format .....	535
25.3.2	Master Transmit Operation .....	536
25.3.3	Master Receive Operation .....	539
25.3.4	Slave Receive Operation .....	541
25.3.5	Slave Transmit Operation .....	544
25.3.6	IRIC Setting Timing and SCL Control .....	545
25.3.7	Noise Canceler .....	547
25.3.8	Sample Flowcharts .....	547
25.3.9	Initialization of Internal State .....	552
25.4	Usage Notes .....	554
<b>Section 26 A/D Converter .....</b>		<b>567</b>
26.1	Overview .....	567
26.1.1	Features .....	567
26.1.2	Block Diagram .....	568
26.1.3	Pin Configuration .....	569
26.1.4	Register Configuration .....	570
26.2	Register Descriptions .....	571
26.2.1	Software-Triggered A/D Result Register (ADR) .....	571
26.2.2	Hardware-Triggered A/D Result Register (AHR) .....	571
26.2.3	A/D Control Register (ADCR) .....	572
26.2.4	A/D Control/Status Register (ADCSR) .....	575
26.2.5	Trigger Select Register (ADTSR) .....	578
26.2.6	Port Mode Register 0 (PMR0) .....	578
26.2.7	Module Stop Control Register (MSTPCR) .....	579
26.3	Interface to Bus Master .....	580
26.4	Operation .....	581
26.4.1	Software-Triggered A/D Conversion .....	581
26.4.2	Hardware- or External-Triggered A/D Conversion .....	582
26.5	Interrupt Sources .....	583
<b>Section 27 Address Trap Controller (ATC) .....</b>		<b>585</b>
27.1	Overview .....	585
27.1.1	Features .....	585
27.1.2	Block Diagram .....	585
27.1.3	Register Configuration .....	586
27.2	Register Descriptions .....	586
27.2.1	Address Trap Control Register (ATCR) .....	586
27.2.2	Trap Address Register 2 to 0 (TAR2 to TAR0) .....	587
27.3	Precautions in Usage .....	588

27.3.1	Basic Operations .....	588
27.3.2	Enable .....	590
27.3.3	Bcc Instruction .....	590
27.3.4	BSR Instruction .....	594
27.3.5	JSR Instruction .....	595
27.3.6	JMP Instruction .....	596
27.3.7	RTS Instruction .....	597
27.3.8	SLEEP Instruction .....	597
27.3.9	Competing Interrupt .....	600
<b>Section 28 Servo Circuits .....</b>		<b>605</b>
28.1	Overview .....	605
28.1.1	Functions .....	605
28.1.2	Block Diagram .....	607
28.2	Servo Port .....	608
28.2.1	Overview .....	608
28.2.2	Block Diagram .....	608
28.2.3	Pin Configuration .....	610
28.2.4	Register Configuration .....	611
28.2.5	Register Descriptions .....	612
28.2.6	DFG/DPG Input Signals .....	618
28.3	Reference Signal Generators .....	619
28.3.1	Overview .....	619
28.3.2	Block Diagram .....	619
28.3.3	Register Configuration .....	621
28.3.4	Register Descriptions .....	622
28.3.5	Description of Operation .....	627
28.4	HSW (Head-Switch) Timing Generator .....	642
28.4.1	Overview .....	642
28.4.2	Block Diagram .....	642
28.4.3	Composition .....	644
28.4.4	Register Configuration .....	645
28.4.5	Register Descriptions .....	645
28.4.6	Description of Operation .....	660
28.4.7	Interrupt .....	666
28.4.8	Cautions .....	667
28.5	Four-Head High-Speed Switching Circuit for Special Playback .....	668
28.5.1	Overview .....	668
28.5.2	Block Diagram .....	668
28.5.3	Pin Configuration .....	669



28.5.4	Register Description.....	670
28.6	Drum Speed Error Detector .....	672
28.6.1	Overview.....	672
28.6.2	Block Diagram.....	672
28.6.3	Register Configuration.....	674
28.6.4	Register Descriptions .....	675
28.6.5	Description of Operation.....	680
28.6.6	$f_H$ Correction in Trick Play Mode.....	682
28.7	Drum Phase Error Detector.....	683
28.7.1	Overview.....	683
28.7.2	Block Diagram.....	683
28.7.3	Register Configuration.....	685
28.7.4	Register Descriptions .....	686
28.7.5	Description of Operation.....	689
28.7.6	Phase Comparison.....	690
28.8	Capstan Speed Error Detector.....	691
28.8.1	Overview.....	691
28.8.2	Block Diagram.....	691
28.8.3	Register Configuration.....	693
28.8.4	Register Descriptions .....	693
28.8.5	Description of Operation.....	697
28.9	Capstan Phase Error Detector .....	699
28.9.1	Overview.....	699
28.9.2	Block Diagram.....	699
28.9.3	Register Configuration.....	701
28.9.4	Register Descriptions .....	702
28.9.5	Description of Operation.....	705
28.10	X-Value and Tracking Adjustment Circuit .....	707
28.10.1	Overview.....	707
28.10.2	Block Diagram.....	707
28.10.3	Register Descriptions .....	709
28.11	Digital Filters .....	712
28.11.1	Overview.....	712
28.11.2	Block Diagram.....	713
28.11.3	Arithmetic Buffer.....	715
28.11.4	Register Configuration.....	716
28.11.5	Register Descriptions .....	717
28.11.6	Filter Characteristics .....	725
28.11.7	Operations in Case of Transient Response.....	727
28.11.8	Initialization of $Z^{-1}$ .....	727

28.12	Additional V Signal Generator .....	729
28.12.1	Overview .....	729
28.12.2	Pin Configuration .....	730
28.12.3	Register Configuration .....	730
28.12.4	Register Description .....	730
28.12.5	Additional V Pulse Signal .....	732
28.13	CTL Circuit .....	735
28.13.1	Overview .....	735
28.13.2	Block Diagram .....	736
28.13.3	Pin Configuration .....	737
28.13.4	Register Configuration .....	737
28.13.5	Register Descriptions .....	738
28.13.6	Operation .....	750
28.13.7	CTL Input Section .....	753
28.13.8	Duty Discriminator .....	756
28.13.9	CTL Output Section .....	762
28.13.10	Trapezoid Waveform Circuit .....	765
28.13.11	Note on CTL Interrupt .....	766
28.14	Frequency Dividers .....	766
28.14.1	Overview .....	766
28.14.2	CTL Frequency Divider .....	766
28.14.3	CFG Frequency Divider .....	770
28.14.4	DFG Noise Removal Circuit .....	778
28.15	Sync Signal Detector .....	781
28.15.1	Overview .....	781
28.15.2	Block Diagram .....	781
28.15.3	Pin Configuration .....	783
28.15.4	Register Configuration .....	783
28.15.5	Register Descriptions .....	784
28.15.6	Noise Detection .....	790
28.15.7	Sync Signal Detector Activation .....	793
28.16	Servo Interrupt .....	794
28.16.1	Overview .....	794
28.16.2	Register Configuration .....	794
28.16.3	Register Description .....	794
28.17	Module Stop Control Register (MSTPCR) .....	801
Section 29 Electrical Characteristics .....		803
29.1	Absolute Maximum Ratings .....	803
29.2	Electrical Characteristics of HD64F2194 .....	804

29.2.1	DC Characteristics of HD64F2194 .....	804
29.2.2	Allowable Output Currents of HD64F2194 and HD64F2194C .....	810
29.2.3	AC Characteristics of HD64F2194 and HD64F2194C .....	811
29.2.4	Serial Interface Timing of HD64F2194 and HD64F2194C .....	815
29.2.5	A/D Converter Characteristics of HD64F2194 and HD64F2194C .....	820
29.2.6	Servo Section Electrical Characteristics of HD64F2194 and HD64F2194C .....	821
29.2.7	FLASH Memory Characteristics .....	824
29.2.8	Usage Note .....	825
29.3	Electrical Characteristics of HD6432194, HD6432193, HD6432192, HD6432191, HD6432194C, HD6432194B, and HD6432194A .....	826
29.3.1	DC Characteristics of HD6432194, HD6432193, HD6432192, HD6432191, HD6432194C, HD6432194B, and HD6432194A .....	826
29.3.2	Allowable Output Currents of HD6432194, HD6432193, HD6432192, HD6432191, HD6432194C, HD6432194B, and HD6432194A .....	832
29.3.3	AC Characteristics of HD6432194, HD6432193, HD6432192, HD6432191, HD6432194C, HD6432194B, and HD6432194A .....	833
29.3.4	Serial Interface Timing of HD6432194, HD6432193, HD6432192, HD6432191, HD6432194C, HD6432194B, and HD6432194A .....	837
29.3.5	A/D Converter Characteristics of HD6432194, HD6432193, HD6432192, HD6432191, HD6432194C, HD6432194B, and HD6432194A .....	842
29.3.6	Servo Section Electrical Characteristics of HD6432194, HD6432193, HD6432192, HD6432191, HD6432194C, HD6432194B, and HD6432194A .....	843
Appendix A Instruction Set .....		847
A.1	Instructions .....	847
A.2	Instruction Codes .....	858
A.3	Operation Code Map .....	868
A.4	Number of Execution States .....	872
A.5	Bus Status during Instruction Execution .....	883
A.6	Change of Condition Codes .....	899
Appendix B Internal I/O Registers .....		904
B.1	Addresses .....	904
B.2	Function List .....	913
Appendix C Pin Circuit Diagrams .....		1018
C.1	Pin Circuit Diagrams .....	1018
Appendix D Port States in the Difference Processing States .....		1032
D.1	Pin Circuit Diagrams .....	1032

Appendix E Usage Notes .....	1033
E.1 Power Supply Rise and Fall Order.....	1033
E.2 Pin Handling when the High-Speed Switching Circuit for Four-Head Special Playback Is Not Used .....	1034
E.3 Sample External Circuits .....	1035
Appendix F List of Product Codes .....	1036
Appendix G External Dimensions .....	1037

# Section 1 Overview

## 1.1 Overview

The H8S/2194 Group and H8S/2194C Group comprise microcomputers (MCUs) built around the H8S/2000 CPU, employing Renesas Technology proprietary architecture, and equipped with supporting modules on-chip.

The H8S/2000 has an internal 32-bit architecture, is provided with sixteen 16-bit general registers and a concise, optimized instruction set designed for high-speed operation, and can address a 16-Mbyte linear address space. The instruction set is upward-compatible with H8/300 and H8/300H CPU instructions at the object-code level, facilitating migration from the H8/300, H8/300L, or H8/300H Series.

The H8S/2194 Group and H8S/2194C Group are incorporated with digital servo circuit, ROM, RAM, seven types of timers, three types of PWM, two types of serial communication interface, I<sup>2</sup>C bus interface, A/D converter, and I/O port as on-chip supporting modules.

The on-chip ROM is either flash memory (F-ZTAT™\*) or mask ROM, with a capacity of 256, 192, 160, 128, 112, 96, or 80 kbytes. ROM is connected to the CPU via a 16-bit data bus, enabling both byte and word data to be accessed in one state. Instruction fetching has been speeded up, and processing speed increased.

The features of the H8S/2194 Group and H8S/2194C Group are shown in table 1.1.

Note: \* F-ZTAT is a trademark of Renesas Technology Corp.

**Table 1.1 Features**

Item	Specifications
CPU	<ul style="list-style-type: none"> <li>• General-register architecture               <ul style="list-style-type: none"> <li>— Sixteen 16-bit general registers (also usable as sixteen 8-bit registers or eight 32-bit registers)</li> </ul> </li> <li>• High-speed operation suitable for real-time control               <ul style="list-style-type: none"> <li>— Maximum operating frequency: 10 MHz/4 to 5.5 V Operable by 32-kHz subclock</li> <li>— High-speed arithmetic operations                   <ul style="list-style-type: none"> <li>8/16/32-bit register-register add/subtract: 100 ns (10-MHz operation)</li> <li>16 × 16-bit register-register multiply: 2000 ns (10-MHz operation)</li> <li>32 ÷ 16-bit register-register divide: 2000 ns (10-MHz operation)</li> </ul> </li> </ul> </li> <li>• Instruction set suitable for high-speed operation               <ul style="list-style-type: none"> <li>— Sixty-five basic instructions</li> <li>— 8/16/32-bit transfer/arithmetic and logic instructions</li> <li>— Unsigned/signed multiply and divide instructions</li> <li>— Powerful bit-manipulation instructions</li> </ul> </li> <li>• CPU operating modes               <ul style="list-style-type: none"> <li>— Advanced mode: 16-Mbyte address space</li> </ul> </li> </ul>
Timer	<p data-bbox="286 847 683 868">Seven types of timer are incorporated</p> <ul style="list-style-type: none"> <li>• Timer A               <ul style="list-style-type: none"> <li>— 8-bit interval timer</li> <li>— Clock source can be selected among 8 types of internal clock of which frequencies are divided from the system clock (<math>\phi</math>) and subclock (<math>\phi</math>SUB)</li> <li>— Functions as clock time base by subclock input</li> </ul> </li> <li>• Timer B               <ul style="list-style-type: none"> <li>— Functions as 8-bit interval timer or reload timer</li> <li>— Clock source can be selected among 7 types of internal clock or external event input</li> </ul> </li> <li>• Timer J               <ul style="list-style-type: none"> <li>— Functions as two 8-bit down counters or one 16-bit down counter (reload timer/event counter timer/timer output, etc., 5 types of operation modes)</li> <li>— Remote controlled transmit function</li> <li>— Take up/Supply Reel Pulse Frequency division</li> </ul> </li> </ul>

Item	Specifications
Timer	<ul style="list-style-type: none"> <li>• Timer L               <ul style="list-style-type: none"> <li>— 8-bit up/down counter</li> <li>— Clock source can be selected among 2 types of internal clock, CFG frequency division signal, and PB and REC-CTL (control pulse)</li> <li>— Compare-match clearing function/auto reload function</li> </ul> </li> <li>• Timer R               <ul style="list-style-type: none"> <li>— Three reload timers</li> <li>— Mode discrimination</li> <li>— Reel control</li> <li>— Capstan motor acceleration/deceleration detection function</li> <li>— Slow tracking mono-multi</li> </ul> </li> <li>• Timer X1               <ul style="list-style-type: none"> <li>— 16-bit free-running counter</li> <li>— Clock source can be selected among 3 types of internal clock and DVCFG</li> <li>— Two output compare outputs</li> <li>— Four input capture inputs</li> </ul> </li> <li>• Watchdog timer               <ul style="list-style-type: none"> <li>— Functions as watchdog timer or 8-bit interval timer</li> <li>— Generates reset signal or NMI at overflow</li> </ul> </li> </ul>
Prescaler unit	<ul style="list-style-type: none"> <li>• Divides system clock frequency and generates frequency division clock for supporting module functions</li> <li>• Divides subclock frequency and generates input clock for Timer A (clock time base)</li> <li>• Generates 8-bit PWM frequency and duty period</li> <li>• 8-bit input capture at external signal edge</li> <li>• Frequency division clock output enabled</li> </ul>
PWM	<p data-bbox="298 1177 699 1201">Three types of PWM are incorporated</p> <ul style="list-style-type: none"> <li>• 14-bit PWM: Pulse resolution type × 1 channel</li> <li>• 8-bit PWM: Duty control type × 4 channels</li> <li>• 12-bit PWM: Pulse pitch control type × 2 channels</li> </ul>

<b>Item</b>	<b>Specifications</b>
Serial communication interface (SCI)	<p>Two types of serial communication interface is incorporated</p> <ul style="list-style-type: none"><li>• SCI1<ul style="list-style-type: none"><li>— Asynchronous mode or synchronous mode selectable</li><li>— Desired bit rate selectable with built-in baud rate generator</li><li>— Multiprocessor communication function</li></ul></li><li>• SCI2<ul style="list-style-type: none"><li>— 32-byte data automatically transferrable</li><li>— Transfer clock selectable among seven types of internal/external clock</li></ul></li></ul>
I <sup>2</sup> C bus interface	<ul style="list-style-type: none"><li>• Conforms to Phillips I<sup>2</sup>C bus interface standard</li><li>• Single master mode/slave mode</li><li>• Arbitration lost condition can be identified</li><li>• Supports two slave addresses</li></ul>
A/D converter	<ul style="list-style-type: none"><li>• Resolution: 10 bits</li><li>• Input: 12 channels</li><li>• High-speed conversion: 13.4 μs minimum conversion time (10-MHz operation)</li><li>• Sample-and-hold function</li><li>• A/D conversion can be activated by software or external trigger</li></ul>
Address trap controller	<ul style="list-style-type: none"><li>• Interrupt occurs when the preset address is found during bus cycle</li><li>• To-be-trapped addresses can be individually set at three different locations</li></ul>
I/O port	<ul style="list-style-type: none"><li>• 60 input/output pins</li><li>• 8 input-only pins</li><li>• Can be switched for each supporting module</li></ul>
Servo circuit	<p>Digital servo circuits on-chip</p> <ul style="list-style-type: none"><li>• Input and output circuits</li><li>• Error detection circuit</li><li>• Phase and gain compensation</li></ul>
Sync signal detector	<p>On-chip sync signal detection circuit</p> <ul style="list-style-type: none"><li>• Can separately detect horizontal and vertical sync signals</li><li>• Noise detection function</li></ul>

---



Item	Specifications																																						
Memory	<ul style="list-style-type: none"> <li>Flash memory or mask ROM</li> <li>High-speed static RAM</li> </ul> <table border="1"> <thead> <tr> <th>Product Name</th> <th>ROM</th> <th>RAM</th> </tr> </thead> <tbody> <tr> <td>H8S/2194C</td> <td>256 kbytes</td> <td>6 kbytes</td> </tr> <tr> <td>H8S/2194B</td> <td>192 kbytes</td> <td>6 kbytes</td> </tr> <tr> <td>H8S/2194A</td> <td>160 kbytes</td> <td>6 kbytes</td> </tr> <tr> <td>H8S/2194</td> <td>128 kbytes</td> <td>3 kbytes</td> </tr> <tr> <td>H8S/2193</td> <td>112 kbytes</td> <td>3 kbytes</td> </tr> <tr> <td>H8S/2192</td> <td>96 kbytes</td> <td>3 kbytes</td> </tr> <tr> <td>H8S/2191</td> <td>80 kbytes</td> <td>3 kbytes</td> </tr> </tbody> </table>	Product Name	ROM	RAM	H8S/2194C	256 kbytes	6 kbytes	H8S/2194B	192 kbytes	6 kbytes	H8S/2194A	160 kbytes	6 kbytes	H8S/2194	128 kbytes	3 kbytes	H8S/2193	112 kbytes	3 kbytes	H8S/2192	96 kbytes	3 kbytes	H8S/2191	80 kbytes	3 kbytes														
Product Name	ROM	RAM																																					
H8S/2194C	256 kbytes	6 kbytes																																					
H8S/2194B	192 kbytes	6 kbytes																																					
H8S/2194A	160 kbytes	6 kbytes																																					
H8S/2194	128 kbytes	3 kbytes																																					
H8S/2193	112 kbytes	3 kbytes																																					
H8S/2192	96 kbytes	3 kbytes																																					
H8S/2191	80 kbytes	3 kbytes																																					
Power-down state	<ul style="list-style-type: none"> <li>Medium-speed mode</li> <li>Sleep mode</li> <li>Module stop mode</li> <li>Standby mode</li> <li>Subclock operation</li> <li>Subactive mode, watch mode, subsleep mode</li> </ul>																																						
Interrupt controller	<ul style="list-style-type: none"> <li>Seven external interrupt pins (NMI, IRQ5 to IRQ0)</li> <li>38 internal interrupt sources</li> <li>Three priority levels settable</li> </ul>																																						
Clock pulse generator	<p>Two types of clock pulse generator on-chip</p> <ul style="list-style-type: none"> <li>System clock pulse generator: 8 to 10 MHz</li> <li>Subclock pulse generator: 32.768 kHz</li> </ul>																																						
Packages	<ul style="list-style-type: none"> <li>112-pin plastic QFP (FP-112)</li> </ul>																																						
Product lineup	<table border="1"> <thead> <tr> <th rowspan="2">Group</th> <th colspan="3">Part No.</th> <th rowspan="2">Packages</th> </tr> <tr> <th>Mask ROM Versions</th> <th>F-ZTAT Versions</th> <th>ROM/RAM (bytes)</th> </tr> </thead> <tbody> <tr> <td rowspan="3">H8S/2194C</td> <td>HD6432194C</td> <td>HD64F2194C</td> <td>256 k/6 k</td> <td>FP-112</td> </tr> <tr> <td>HD6432194B</td> <td>—</td> <td>192 k/6 k</td> <td>FP-112</td> </tr> <tr> <td>HD6432194A</td> <td>—</td> <td>160 k/6 k</td> <td>FP-112</td> </tr> <tr> <td rowspan="4">H8S/2194</td> <td>HD6432194</td> <td>HD64F2194</td> <td>128 k/3 k</td> <td>FP-112</td> </tr> <tr> <td>HD6432193</td> <td>—</td> <td>112 k/3 k</td> <td>FP-112</td> </tr> <tr> <td>HD6432192</td> <td>—</td> <td>96 k/3 k</td> <td>FP-112</td> </tr> <tr> <td>HD6432191</td> <td>—</td> <td>80 k/3 k</td> <td>FP-112</td> </tr> </tbody> </table>	Group	Part No.			Packages	Mask ROM Versions	F-ZTAT Versions	ROM/RAM (bytes)	H8S/2194C	HD6432194C	HD64F2194C	256 k/6 k	FP-112	HD6432194B	—	192 k/6 k	FP-112	HD6432194A	—	160 k/6 k	FP-112	H8S/2194	HD6432194	HD64F2194	128 k/3 k	FP-112	HD6432193	—	112 k/3 k	FP-112	HD6432192	—	96 k/3 k	FP-112	HD6432191	—	80 k/3 k	FP-112
Group	Part No.			Packages																																			
	Mask ROM Versions	F-ZTAT Versions	ROM/RAM (bytes)																																				
H8S/2194C	HD6432194C	HD64F2194C	256 k/6 k	FP-112																																			
	HD6432194B	—	192 k/6 k	FP-112																																			
	HD6432194A	—	160 k/6 k	FP-112																																			
H8S/2194	HD6432194	HD64F2194	128 k/3 k	FP-112																																			
	HD6432193	—	112 k/3 k	FP-112																																			
	HD6432192	—	96 k/3 k	FP-112																																			
	HD6432191	—	80 k/3 k	FP-112																																			

## 1.2 Internal Block Diagram

An internal block diagram of the chip is shown in figure 1.1.

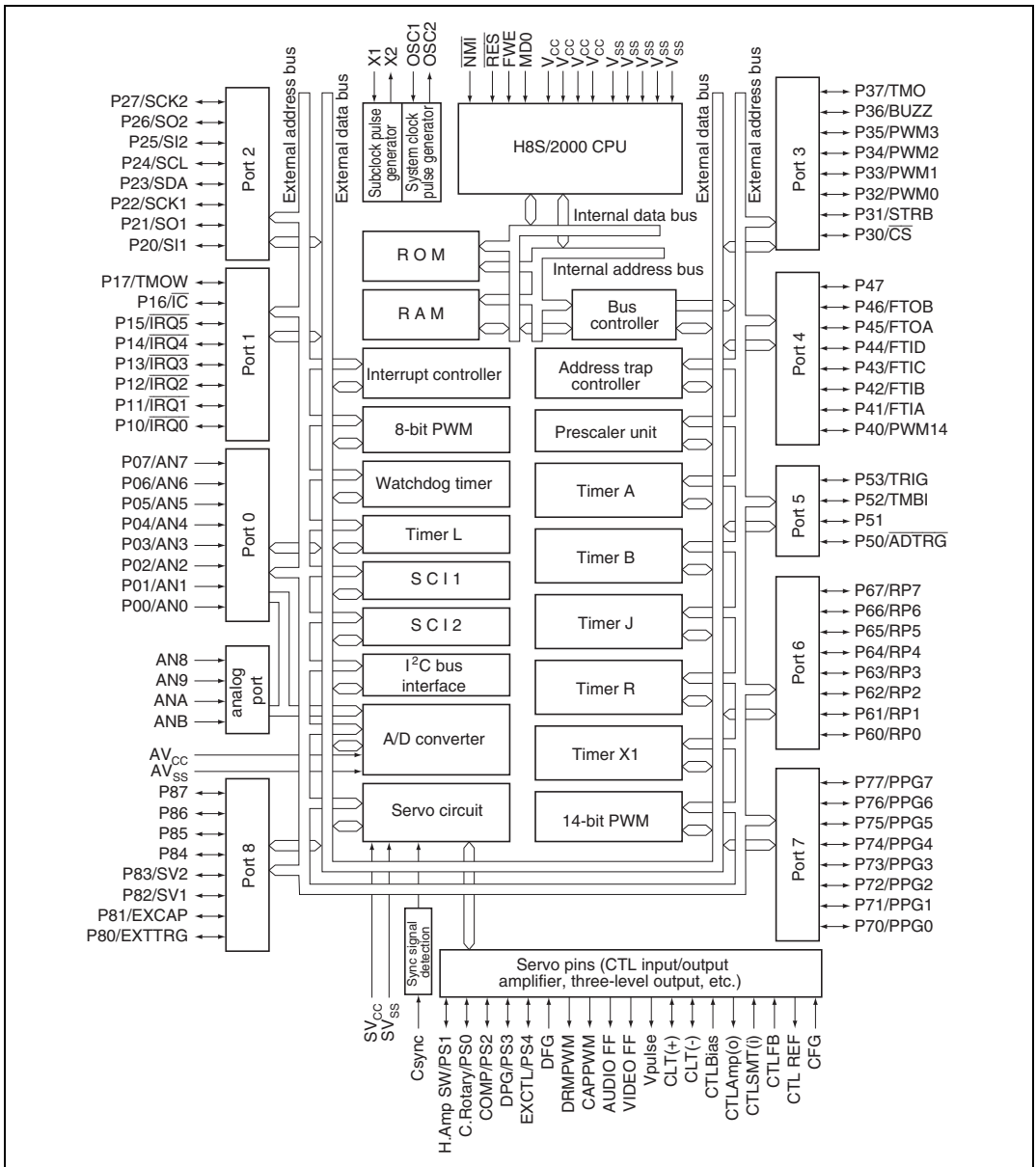


Figure 1.1 Internal Block Diagram of H8S/2194 Group

## 1.3 Pin Arrangement and Functions

### 1.3.1 Pin Arrangement

The pin arrangement of the chip is shown in figure 1.2.

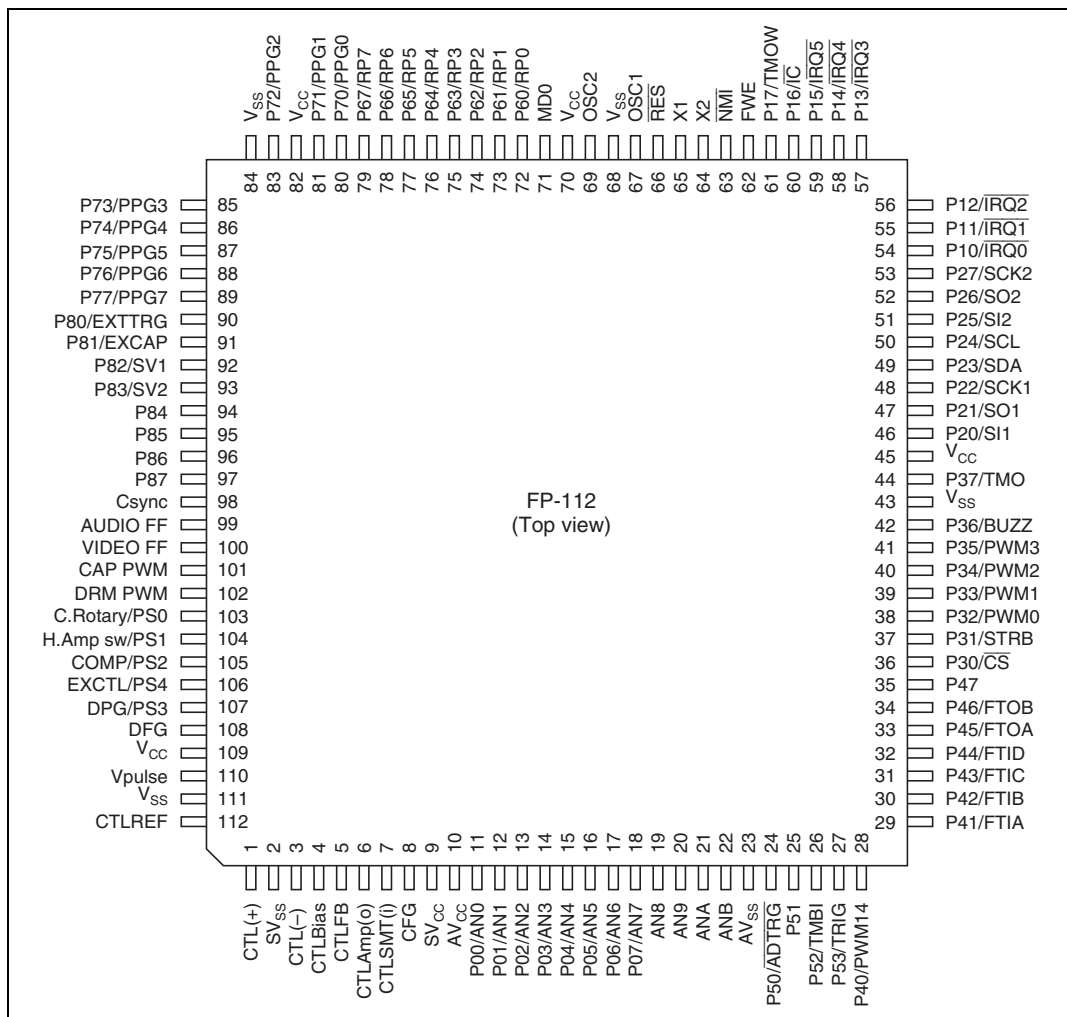


Figure 1.2 Pin Arrangement of H8S/2194 Group

### 1.3.2 Pin Functions

Table 1.2 summarizes the functions of the chip's pins.

**Table 1.2 Pin Functions**

Type	Symbol	Pin No.	I/O	Name and Function
Power supply	Vcc	45, 70, 82, 109	Input	<u>Power supply:</u> All Vcc pins should be connected to the system power supply (+ 5V)
	Vss	43, 68, 84, 111	Input	<u>Ground:</u> All Vss pins should be connected to the system power supply (0 V)
	SVcc	9	Input	<u>Servo power supply:</u> SVcc pin should be connected to the servo analog power supply (+5 V)
	SVss	2	Input	<u>Servo ground:</u> SVss pin should be connected to the servo analog power supply (0 V)
	AVcc	10	Input	<u>Analog power supply:</u> Power supply pin for A/D converter. It should be connected to the system power supply (+5 V) when the A/D converter is not used
	AVss	23	Input	<u>Analog ground:</u> Ground pin for A/D converter. It should be connected to the system power supply (0 V)
	Clock	OSC1	67	Input
OSC2		69	Output	
X1		65	Input	Connected to a 32.768 kHz crystal oscillator. See section 10, Clock Pulse Generator, for typical connection diagrams
X2		64	Output	
Operating mode control	MD0	71	Input	<u>Mode pins:</u> These pins set the operating mode. These pins should not be changed while the MCU is in operation

Type	Symbol	Pin No.	I/O	Name and Function
System control	$\overline{\text{RES}}$	66	Input	<u>Reset input:</u> When this pin is driven low, the chip is reset
	FWE	62	Input	<u>Flash memory enable:</u> Enables/disables flash memory programming. This pin is available only with MCU with flash memory on-chip. For mask ROM type, do not connect anything to this pin
Interrupts	$\overline{\text{IRQ0}}$	54	Input	<u>External interrupt request 0:</u> External interrupt input pin for which rising edge sense, falling edge sense or both edges sense are selectable
	$\overline{\text{IRQ1}}$	55	Input	<u>External interrupt requests 1 to 5:</u>
	$\overline{\text{IRQ2}}$	56		External interrupt input pins for which rising or falling edge sense are selectable
	$\overline{\text{IRQ3}}$	57		
	$\overline{\text{IRQ4}}$	58		
	$\overline{\text{IRQ5}}$	59		
	NMI	63	Input	<u>Nonmaskable interrupt:</u> Nonmaskable interrupt input pin for which rising edge sense, falling edge sense or both edges sense are selectable
Prescaler unit	$\overline{\text{IC}}$	60	Input	<u>Input capture input:</u> Input capture input pin for prescaler unit
	TMOW	61	Output	<u>Frequency division clock output:</u> Output pin for clock of which frequency is divided by prescaler
Timers	TMBI	26	Input	<u>Timer B event input:</u> Input pin for events to be input to Timer B counter
	$\overline{\text{IRQ1}}$	55	Input	<u>Timer J event input:</u>
	$\overline{\text{IRQ2}}$	56		Input pin for events to be input to Timer J RDT-1 or RDT-2 counter
	TMO	44	Output	
	BUZZ	42	Output	<u>Timer J buzzer output:</u> Output pin for toggle which is selectable among fixed frequency, 1 Hz frequency divided from subclock (32 kHz), and frequency division CTL signal

Type	Symbol	Pin No.	I/O	Name and Function
Timers	$\overline{\text{IRQ3}}$	57	Input	<u>Timer R input capture:</u> Input pin for input capture of Timer R TMRU-1 or TMRU-2
	FTOA	33	Output	<u>Timer X1 output compare A and B output:</u> Output pin for output compare A and B of Timer X1
	FTOB	34		
	FTIA	29	Input	<u>Timer X1 input capture A, B, C, and D input:</u> Input pin for input capture A, B, C, and D of Timer X1
	FTIB	30		
FTIC	31			
FTID	32			
PWM	PWM0	38	Output	<u>8-bit PWM square waveform output:</u> Output pin for waveform generated by 8-bit PWM 0, 1, 2, and 3
	PWM1	39		
	PWM2	40		
	PWM3	41		
	PWM14	28	Output	<u>14-bit PWM square waveform output:</u> Output pin for waveform generated by 14-bit PWM
Serial communication interface (SCI)	SCK1	48	Input/output	<u>SCI clock input/output:</u> Clock input pins for SCI 1 and 2
	SCK2	53		
	SI1	46	Input	<u>SCI receive data input:</u> Receive data input pins for SCI 1 and 2
	SI2	51		
	SO1	47	Output	<u>SCI transmit data output:</u> Transmit data output pins for SCI 1 and 2
	SO2	52		
	STRB	37	Output	<u>SCI2 strobe output:</u> This pin outputs strobe pulse for each byte transmit by SCI2
	$\overline{\text{CS}}$	36	Input	<u>SCI2 chip select input:</u> This pin controls the transfer start of SCI2
I <sup>2</sup> C bus interface	SCL	50	Input/output	<u>I<sup>2</sup>C bus interface clock input/output:</u> Clock input/output pin for I <sup>2</sup> C bus interface
	SDA	49	Input/output	<u>I<sup>2</sup>C bus interface data input/output:</u> Data input/output pin for I <sup>2</sup> C bus interface

Type	Symbol	Pin No.	I/O	Name and Function
A/D converter	AN7 to AN0	18 to 11	Input	<u>Analog input channels 7 to 0:</u> Analog data input pins. A/D conversion is started by a software triggering
	AN8	19	Input	<u>Analog input channels 8, 9, A, and B:</u> Analog data input pins. A/D conversion is started by an external, hardware, or software triggering
	AN9	20		
	ANA	21		
	ANB	22		
	ADTRG	24	Input	<u>A/D conversion external trigger input:</u> Pin for input of an external trigger to start A/D conversion
Servo circuits	AUDIO FF	99	Output	<u>Audio FF:</u> Output pin for audio head switching signal
	VIDEO FF	100	Output	<u>Video FF:</u> Output pin for video head switching signal
	CAPPWM	101	Output	<u>Capstan mix:</u> 12-bit PWM output pin giving result of capstan speed error and phase error after filtering
	DRMPWM	102	Output	<u>Drum mix:</u> 12-bit PWM output pin giving result of drum speed error and phase error after filtering
	Vpulse	110	Output	<u>Additional V pulse:</u> Three-level output pin for additional V signal synchronized to the Video FF signal
	C.Rotary/ PS0	103	Output, input/ output	<u>Color rotary signal:</u> Output pin for color signal processing control signal in four-head special-effects playback
	H.AmpSW/P S1	104	Output, input/ output	<u>Head-amp switch:</u> Output pin for preamplifier output select signal in four-head special-effects playback. This pin can also be used as a general port when not used
	COMP/ PS2	105	Input, input/ output	<u>Compare input:</u> Input pin for signal giving the result of preamplifier output comparison in four-head special-effects playback. This pin can also be used as a general port when not used
	CTL (+) CTL (-)	1 3	Input/ output	<u>CTL head (+) and (-) pins:</u> I/O pins for CTL signals
CTL Bias	4	Input	<u>CTL primary amp bias supply:</u> Bias supply pin for CTL primary amp	

Type	Symbol	Pin No.	I/O	Name and Function
Servo circuits	CTL Amp (o)	6	Output	<u>CTL amp output:</u> Output pin for CTL amp
	CTL SMT (I)	7	Input	<u>CTL Schmitt amp input:</u> Input pin for CTL Schmitt amp
	CTLFB	5	Input	<u>CLT feedback input:</u> Input pin for CTL amp high-range characteristics control
	CTLREF	112	Output	<u>CTL amp reference voltage output:</u> Output pin for 1/2 Vcc (SV)
	CFG	8	Input	<u>Capstan FG input:</u> Schmitt comparator input pin for CFG signal
	DFG	108	Input	<u>Drum FG input:</u> Schmitt input pin for DFG signal
	DPG/PS3	107	Input, input/output	<u>Drum PG input:</u> Schmitt input pin for DPG signal. This pin can also be used as a general port when not used
	EXCTL/PS4	106	Input, input/output	<u>External CTL input:</u> Input pin for external CTL signal. This pin can also be used as a general port when not used
	Csync	98	Input	<u>Mixed sync signal input:</u> Input pin for mixed sync signal
	EXCAP	91	Input	<u>Capstan external sync signal input:</u> Signal input pin for external synchronization of capstan phase control
	EXTTRG	90	Input	<u>External trigger signal input:</u> Signal input pin for synchronization with reference signal generator
	SV1	92	Output	<u>Servo monitor output pin 1:</u> Output pin for servo module internal signal
	SV2	93	Output	<u>Servo monitor output pin 2:</u> Output pin for servo module internal signal
PPG7 to PPG0	89 to 85, 83, 81, 80	Output	<u>PPG:</u> Output pin for HSW timing generator. To be used when head switching is required as well as Audio FF and Video FF	



Type	Symbol	Pin No.	I/O	Name and Function
I/O port	P07 to P00	11 to 18	Input	<u>Port 0:</u> 8-bit input pins
	P17 to P10	61 to 54	Input/ output	<u>Port 1:</u> 8-bit I/O pins
	P27 to P20	53 to 46	Input/ output	<u>Port 2:</u> 8-bit I/O pins
	P37 to P30	44, 42 to 36	Input/ output	<u>Port 3:</u> 8-bit I/O pins
	P47 to P40	35 to 28	Input/ output	<u>Port 4:</u> 8-bit I/O pins
	P53 to P50	27 to 24	Input/ output	<u>Port 5:</u> 4-bit I/O pins
	P67 to P60	79 to 72	Input/ output	<u>Port 6:</u> 8-bit I/O pins
	P77 to P70	89 to 85, 83, 81, 80	Input/ output	<u>Port 7:</u> 8-bit I/O pins
	P87 to P80	97 to 90	Input/ output	<u>Port 8:</u> 8-bit I/O pins
	RP7 to RP0	79 to 72	Output	<u>Realtime output port:</u> 8-bit realtime output pins
TRIG	27	Input	<u>Realtime output port trigger input:</u> Input pin for realtime output port trigger	

## 1.4 Differences between H8S/2194C Group and H8S/2194 Group

Though the H8S/2194C Group is compatible with the H8S/2194 Group and their supporting modules are almost identical, there are some differences between them as shown below. For details, see the following sections.

**Table 1.3 Differences between H8S/2194C Group and H8S/2194 Group**

	<b>H8S/2194C Group</b>	<b>H8S/2194 Group</b>
ROM	H8S/2194C: 256 kbytes H8S/2194B: 192 kbytes H8S/2194A: 160 kbytes	H8S/2194: 128 kbytes H8S/2193: 112 kbytes H8S/2192: 96 kbytes H8S/2191: 80 kbytes
RAM	H8S/2194C: 6 kbytes H8S/2194B: 6 kbytes H8S/2194A: 6 kbytes	H8S/2194: 3 kbytes H8S/2193: 3 kbytes H8S/2192: 3 kbytes H8S/2191: 3 kbytes
Timer J	Five operating modes: TMJ-2 input clock sources: PSS = $\phi/16384$ , $\phi/2048$ , or $\phi/1024$ ; underflow of TMJ-1, external clock (IRQ2)	Four operating modes: TMJ-2 input clock sources: PSS = $\phi/16384$ or $\phi/2048$ ; underflow of TMJ-1, external clock (IRQ2)
Servo circuit	In the reference signal generator, the servo circuit selects whether reference signals are generated with VD when it is in PB mode, or in free-run	In the reference signal generator, when the servo circuit is in PB mode, reference signals are generated in free-run
Flash ROM	256 kbytes  When the flash ROM control flag is set, use the E (erase) bit and the P (program) bit in flash memory control register 1 (FMLCR1).	128 kbytes  When the flash ROM control flag is set, use the E (erase) bit and the P (program) bit in flash memory control register 2 (FMLCR2).

## Section 2 CPU

### 2.1 Overview

The H8S/2000 CPU is a high-speed central processing unit with an internal 32-bit architecture that is upward-compatible with the H8/300 and H8/300H CPUs. The H8S/2000 CPU has sixteen 16-bit general registers, can address a 16-Mbyte (architecturally 4-Gbyte) linear address space, and is ideal for realtime control.

#### 2.1.1 Features

The H8S/2000 CPU has the following features.

- Upward-compatible with H8/300 and H8/300H CPUs  
Can execute H8/300 and H8/300H object programs
- General-register architecture  
Sixteen 16-bit general registers (also usable as sixteen 8-bit registers or eight 32-bit registers)
- Sixty-five basic instructions  
8/16/32-bit arithmetic and logic instructions  
Multiply and divide instructions  
Powerful bit-manipulation instructions
- Eight addressing modes  
Register direct [Rn]  
Register indirect [@ERn]  
Register indirect with displacement [@(d:16,ERn) or @(d:32,ERn)]  
Register indirect with post-increment or pre-decrement [@ERn+ or @-ERn]  
Absolute address [@aa:8, @aa:16, @aa:24, or @aa:32]  
Immediate [#xx:8, #xx:16, or #xx:32]  
Program-counter relative [@(d:8,PC) or @(d:16,PC)]  
Memory indirect [@@aa:8]
- 16-Mbyte address space  
Program: 16 Mbytes  
Data: 16 Mbytes (4 Gbytes architecturally)

- High-speed operation
  - All frequently-used instructions execute in one or two states
  - Maximum clock rate: 10 MHz
  - 8/16/32-bit register-register add/subtract: 100 ns
  - 8 × 8-bit register-register multiply: 1200 ns
  - 16 ÷ 8-bit register-register divide: 1200 ns
  - 16 × 16-bit register-register multiply: 2000 ns
  - 32 ÷ 16-bit register-register divide: 2000 ns
- Two CPU operating modes
  - Normal mode\*/Advanced mode
- Power-down state
  - Transition to power-down state by SLEEP instruction
  - CPU clock speed selection

Note: \* Normal mode is not available for this LSI.

### 2.1.2 Differences between H8S/2600 CPU and H8S/2000 CPU

The differences between the H8S/2600 CPU and the H8S/2000 CPU are shown below.

- Register configuration
  - The MAC register is supported only by the H8S/2600 CPU.
- Basic instructions
  - The four instructions MAC, CLRMAC, LDMAC, and STMAC are supported only by the H8S/2600 CPU.
- Number of execution states
  - The number of execution states of the MULXU and MULXS instructions differ as follows.

Instruction	Mnemonic	Number of Execution States	
		H8S/2600	H8S/2000
MULXU	MULXU.B Rs, Rd	3	12
	MULXU.W Rs, Erd	4	20
MULXS	MULXS.B Rs, Rd	4	13
	MULXS.W Rs, Erd	5	21

There are also differences in the address space, EXR register functions, power-down state, etc., depending on the product.

### 2.1.3 Differences from H8/300 CPU

In comparison to the H8/300 CPU, the H8S/2000 CPU has the following enhancements.

- More general registers and control registers  
Eight 16-bit extended registers, and one 8-bit control register, have been added.
- Expanded address space  
Normal mode supports the same 64-kbyte address space as the H8/300 CPU.  
Advanced mode supports a maximum 16-Mbyte address space.
- Enhanced addressing mode  
The addressing modes have been enhanced to make effective use of the 16-Mbyte address space.
- Enhanced instructions  
Addressing modes of bit-manipulation instructions have been enhanced.  
Signed multiply and divide instructions have been added.  
Two-bit shift instructions have been added.  
Instructions for saving and restoring multiple registers have been added.  
A test and set instruction has been added.
- Higher speed  
Basic instructions execute twice as fast.

### 2.1.4 Differences from H8/300H CPU

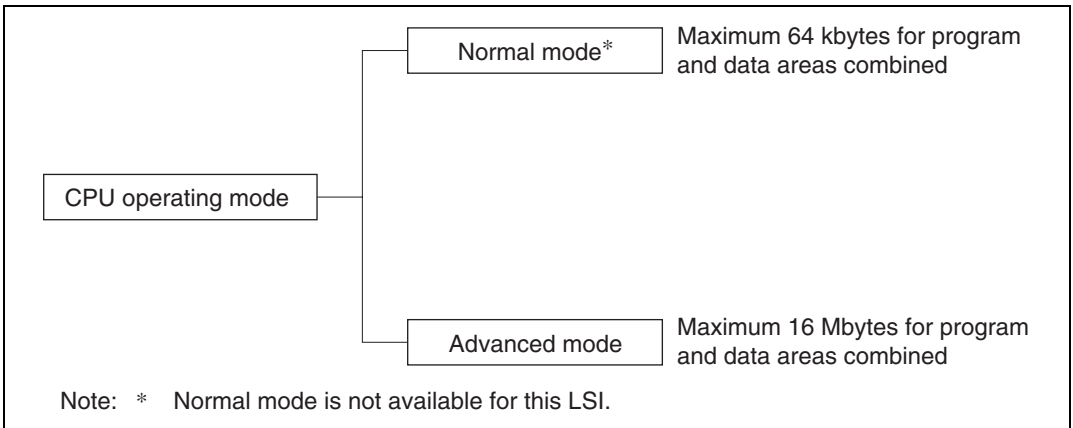
In comparison to the H8/300H CPU, the H8S/2000 CPU has the following enhancements.

- Additional control register  
One 8-bit control register has been added.
- Enhanced instructions  
Addressing modes of bit-manipulation instructions have been enhanced.  
Two-bit shift instructions have been added.  
Instructions for saving and restoring multiple registers have been added.  
A test and set instruction has been added.
- Higher speed  
Basic instructions execute twice as fast.

## 2.2 CPU Operating Modes

The H8S/2000 CPU has two operating modes: normal and advanced. Normal mode supports a maximum 64-kbyte address space. Advanced mode supports a maximum 16-Mbyte total address space (architecturally the maximum total address space is 4 Gbytes, with a maximum of 16 Mbytes for the program area and a maximum of 4 Gbytes for the data area).

The mode is selected by the mode pins of the microcontroller.



**Figure 2.1 CPU Operating Modes**

### 2.2.1 Normal Mode

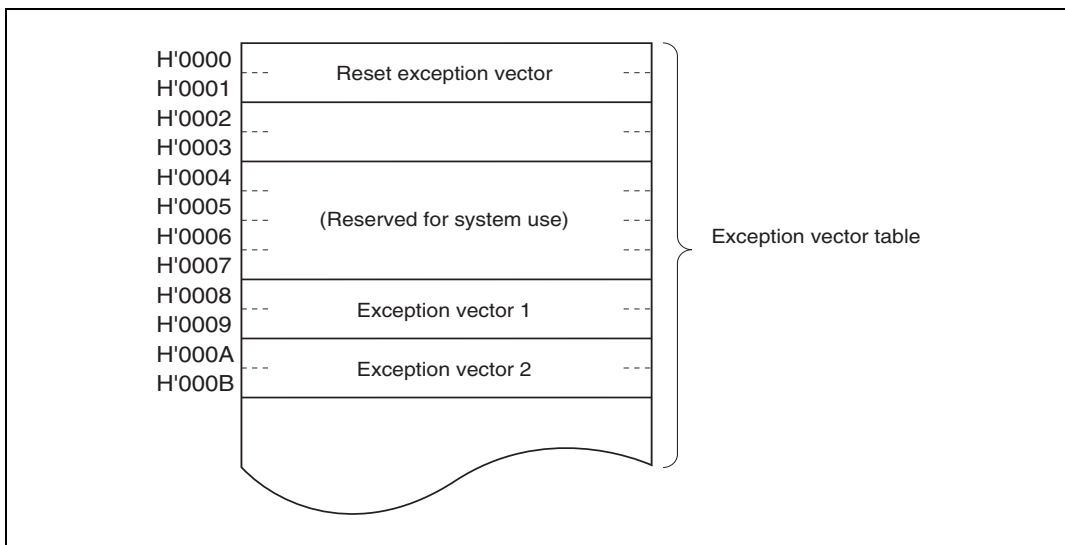
The exception vector table and stack have the same structure as in the H8/300 CPU.

**Address Space:** A maximum address space of 64 kbytes can be accessed.

**Extended Registers (En):** The extended registers (E0 to E7) can be used as 16-bit registers, or as the upper 16-bit segments of 32-bit registers. When En is used as a 16-bit register it can contain any value, even when the corresponding general register (Rn) is used as an address register. If the general register is referenced in the register indirect addressing mode with pre-decrement (@-Rn) or post-increment (@Rn+) and a carry or borrow occurs, however, the value in the corresponding extended register (En) will be affected.

**Instruction Set:** All instructions and addressing modes can be used. Only the lower 16 bits of effective addresses (EA) are valid.

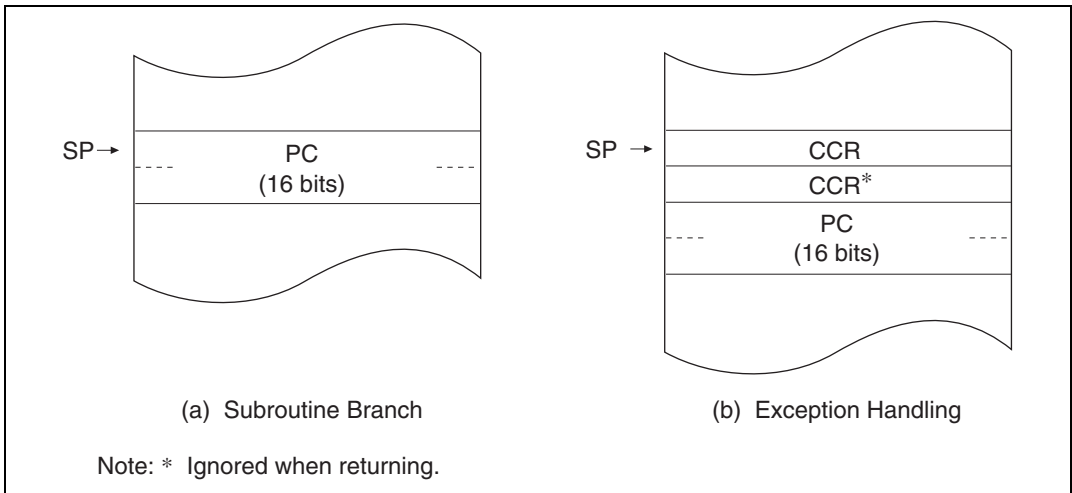
**Exception Vector Table and Memory Indirect Branch Addresses:** In normal mode the top area starting at H'0000 is allocated to the exception vector table. One branch address is stored per 16 bits. The configuration of the exception vector table in normal mode is shown in figure 2.2. For details of the exception vector table, see section 5, Exception Handling.



**Figure 2.2 Exception Vector Table (Normal Mode)**

The memory indirect addressing mode (@@aa:8) employed in the JMP and JSR instructions uses an 8-bit absolute address included in the instruction code to specify a memory operand that contains a branch address. In normal mode the operand is a 16-bit word operand, providing a 16-bit branch address. Branch addresses can be stored in the top area from H'0000 to H'00FF. Note that this area is also used for the exception vector table.

**Stack Structure:** When the program counter (PC) is pushed onto the stack in a subroutine call, and the PC and condition-code register (CCR) are pushed onto the stack in exception handling, they are stored as shown in figure 2.3. The extended control register (EXR) is not pushed onto the stack. For details, see section 5, Exception Handling.



**Figure 2.3 Stack Structure in Normal Mode**

### 2.2.2 Advanced Mode

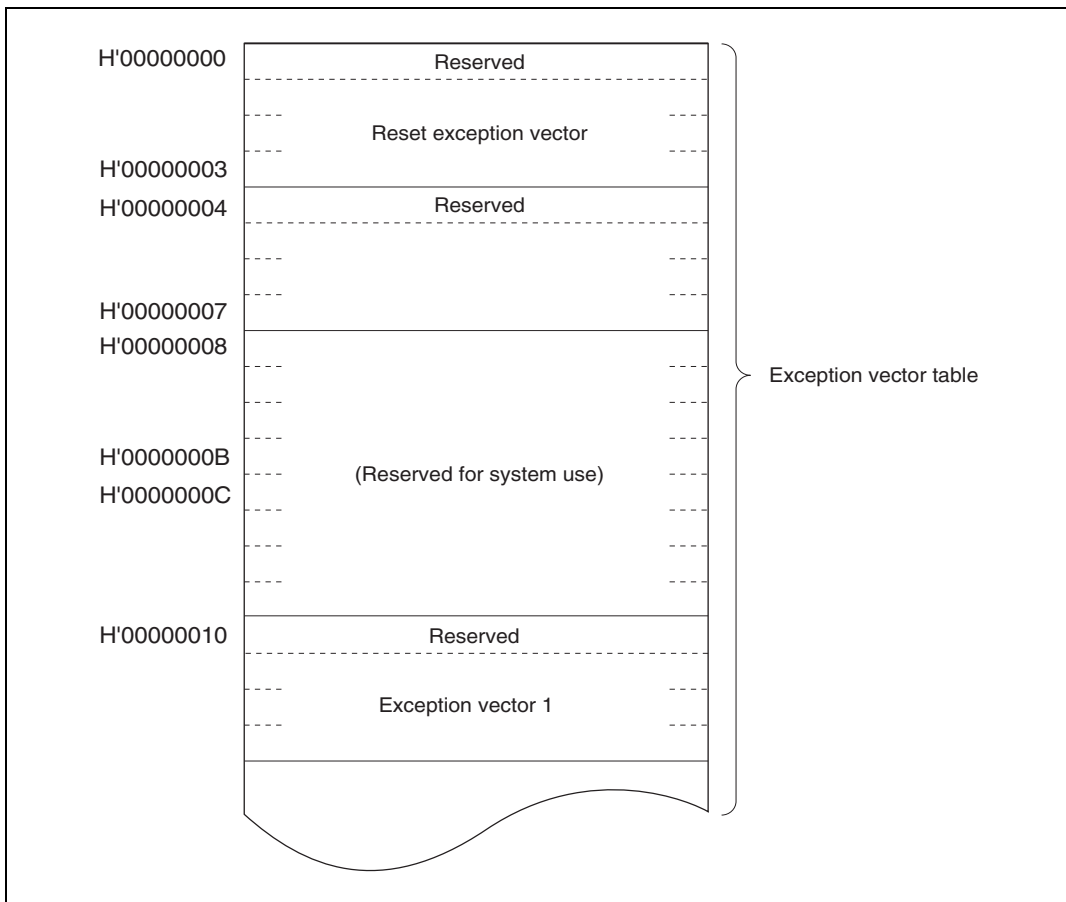
**Address Space:** Linear access is provided to a 16-Mbyte maximum address space (architecturally a maximum 16-Mbyte program area and a maximum 4-Gbyte data area, with a maximum of 4 Gbytes for program and data areas combined).

**Extended Registers (En):** The extended registers (E0 to E7) can be used as 16-bit registers, or as the upper 16-bit segments of 32-bit registers or address registers.

**Instruction Set:** All instructions and addressing modes can be used.

**Exception Vector Table and Memory Indirect Branch Addresses:** In advanced mode the top area starting at H'00000000 is allocated to the exception vector table in units of 32 bits. In each 32 bits, the upper 8 bits are ignored and a branch address is stored in the lower 24 bits (figure 2.4). For details of the exception vector table, see section 5, Exception Handling.

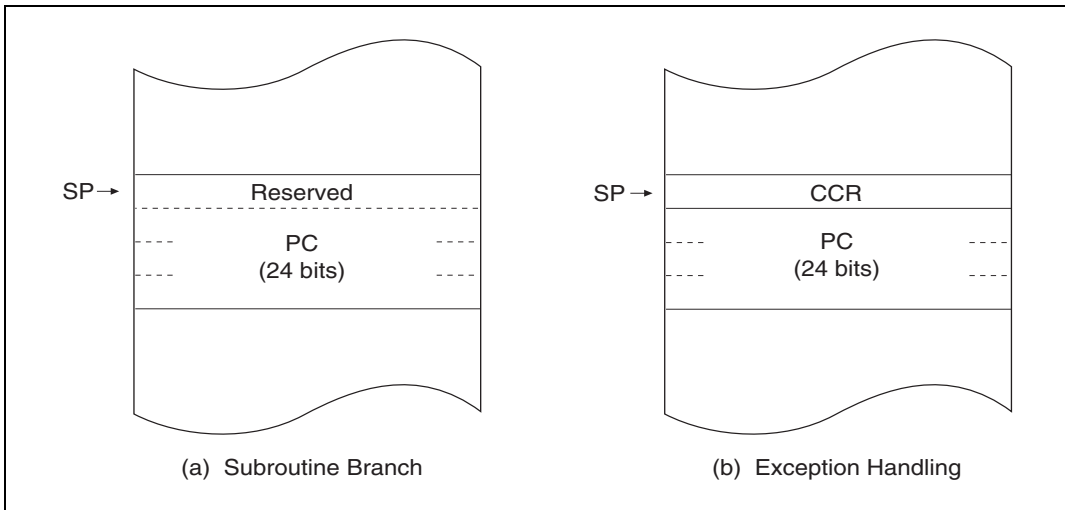




**Figure 2.4 Exception Vector Table (Advanced Mode)**

The memory indirect addressing mode (@@aa:8) employed in the JMP and JSR instructions uses an 8-bit absolute address included in the instruction code to specify a memory operand that contains a branch address. In advanced mode the operand is a 32-bit longword operand, providing a 32-bit branch address. The upper 8 bits of these 32 bits are a reserved area that is regarded as H'00. Branch addresses can be stored in the area from H'00000000 to H'000000FF. Note that the first part of this range is also the exception vector table.

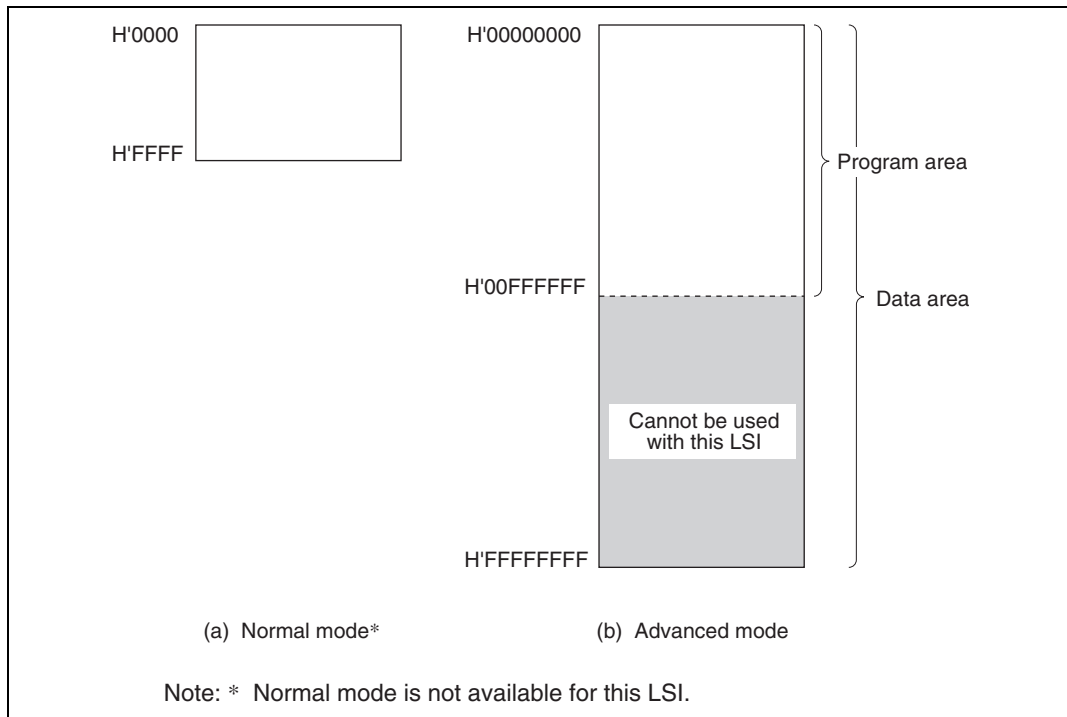
**Stack Structure:** In advanced mode, when the program counter (PC) is pushed onto the stack in a subroutine call, and the PC and condition-code register (CCR) are pushed onto the stack in exception handling, they are stored as shown in figure 2.5. The extended control register (EXR) is not pushed onto the stack. For details, see section 5, Exception Handling.



**Figure 2.5 Stack Structure in Advanced Mode**

## 2.3 Address Space

Figure 2.6 shows a memory map of the H8S/2000 CPU. The H8S/2000 CPU provides linear access to a maximum 64-kbyte address space in normal mode, and a maximum 16-Mbyte (architecturally 4-Gbyte) address space in advanced mode.



**Figure 2.6 Memory Map**

## 2.4 Register Configuration

### 2.4.1 Overview

The CPU has the internal registers shown in figure 2.7. There are two types of registers: general registers and control registers.

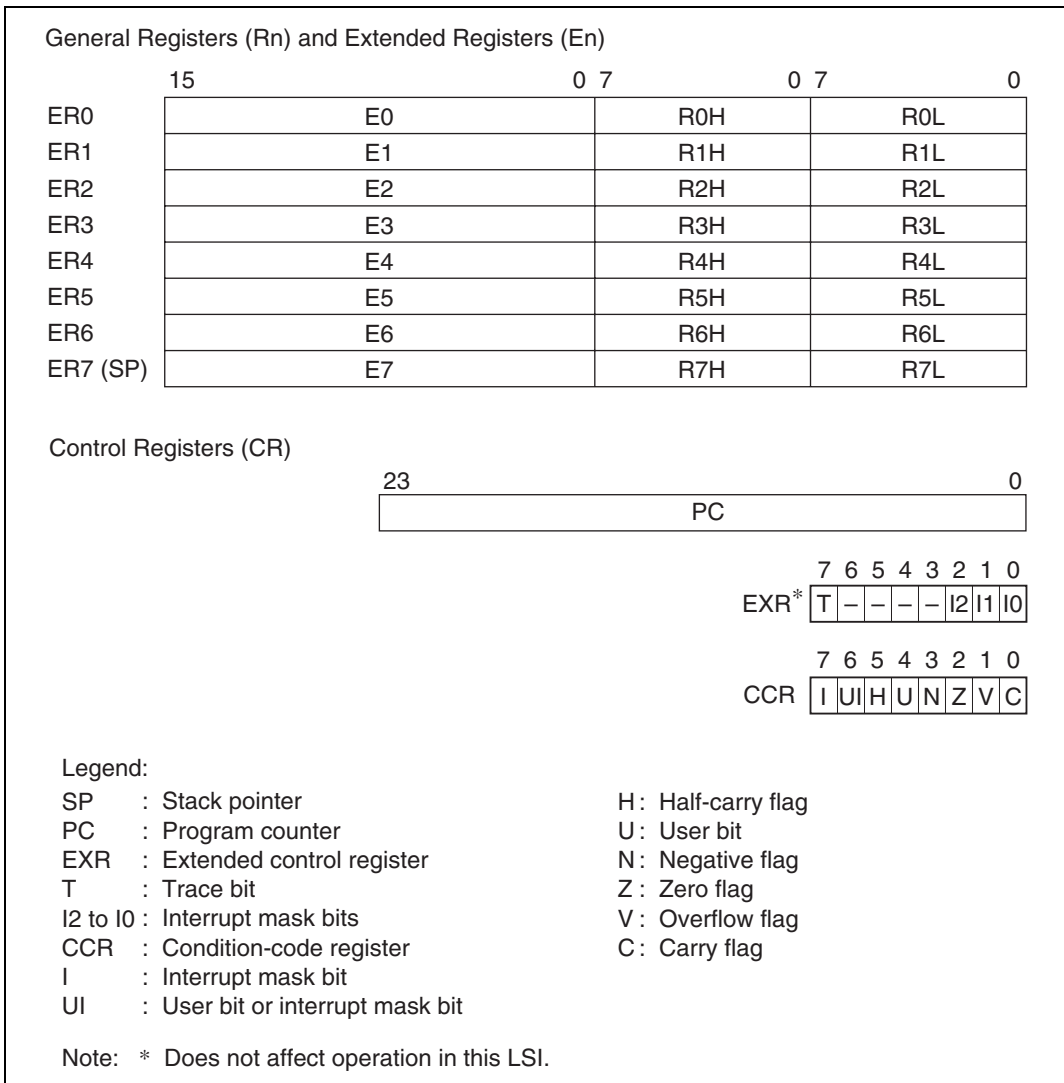


Figure 2.7 CPU Registers

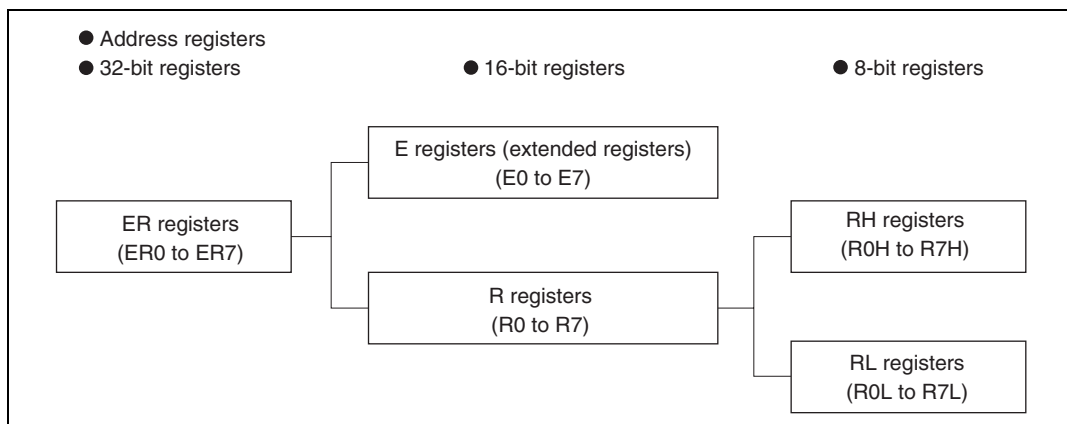
## 2.4.2 General Registers

The CPU has eight 32-bit general registers. These general registers are all functionally alike and can be used as both address registers and data registers. When a general register is used as a data register, it can be accessed as a 32-bit, 16-bit, or 8-bit register. When the general registers are used as 32-bit registers or address registers, they are designated by the letters ER (ER0 to ER7).

The ER registers divide into 16-bit general registers designated by the letters E (E0 to E7) and R (R0 to R7). These registers are functionally equivalent, providing a maximum of sixteen 16-bit registers. The E registers (E0 to E7) are also referred to as extended registers.

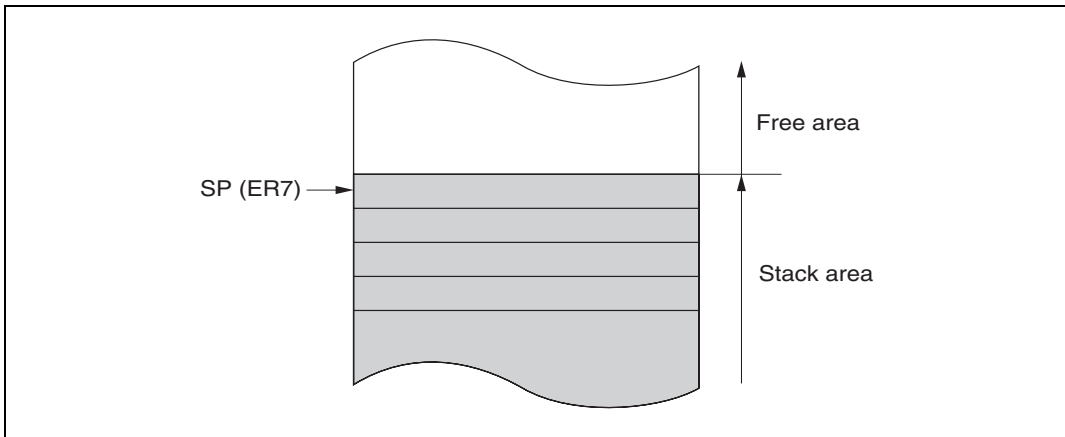
The R registers divide into 8-bit general registers designated by the letters RH (R0H to R7H) and RL (R0L to R7L). These registers are functionally equivalent, providing a maximum of sixteen 8-bit registers.

Figure 2.8 illustrates the usage of the general registers. The usage of each register can be selected independently.



**Figure 2.8 Usage of General Registers**

General register ER7 has the function of stack pointer (SP) in addition to its general-register function, and is used implicitly in exception handling and subroutine calls. Figure 2.9 shows the stack.



**Figure 2.9 Stack**

### 2.4.3 Control Registers

The control registers are the 24-bit program counter (PC), 8-bit extended control register (EXR), and 8-bit condition-code register (CCR).

#### (1) Program Counter (PC)

This 24-bit counter indicates the address of the next instruction the CPU will execute. The length of all CPU instructions is 2 bytes (one word), so the least significant PC bit is ignored. (When an instruction is fetched, the least significant PC bit is regarded as 0.)

#### (2) Extended Control Register (EXR)

An 8-bit register. In this LSI, this register does not affect operation.

**Bit 7—Trace Bit (T):** This bit is reserved. In this LSI, this bit does not affect operation.

**Bits 6 to 3—Reserved:** This bit is reserved. In this LSI, this bit does not affect operation.

**Bits 2 to 0—Interrupt Mask Bits (I2 to I0):** These bits are reserved. In this LSI, these bits do not affect operation.

#### (3) Condition-Code Register (CCR)

This 8-bit register contains internal CPU status information, including an interrupt mask bit (I) and half-carry (H), negative (N), zero (Z), overflow (V), and carry (C) flags.

**Bit 7—Interrupt Mask Bit (I):** Masks interrupts other than NMI when set to 1. (NMI is accepted regardless of the I bit setting.) The I bit is set to 1 by hardware at the start of an exception-handling sequence. For details, see section 6, Interrupt Controller.

**Bit 6—User Bit or Interrupt Mask Bit (UI):** Can be written and read by software using the LDC, STC, ANDC, ORC, and XORC instructions. This bit can also be used as an interrupt mask bit. For details, see section 6, Interrupt Controller.

**Bit 5—Half-Carry Flag (H):** When the ADD.B, ADDX.B, SUB.B, SUBX.B, CMP.B, or NEG.B instruction is executed, this flag is set to 1 if there is a carry or borrow at bit 3, and cleared to 0 otherwise. When the ADD.W, SUB.W, CMP.W, or NEG.W instruction is executed, the H flag is set to 1 if there is a carry or borrow at bit 11, and cleared to 0 otherwise. When the ADD.L, SUB.L, CMP.L, or NEG.L instruction is executed, the H flag is set to 1 if there is a carry or borrow at bit 27, and cleared to 0 otherwise.

**Bit 4—User Bit (U):** Can be written and read by software using the LDC, STC, ANDC, ORC, and XORC instructions.

**Bit 3—Negative Flag (N):** Stores the value of the most significant bit (sign bit) of data.

**Bit 2—Zero Flag (Z):** Set to 1 to indicate zero data, and cleared to 0 to indicate non-zero data.

**Bit 1—Overflow Flag (V):** Set to 1 when an arithmetic overflow occurs, and cleared to 0 otherwise.

**Bit 0—Carry Flag (C):** Set to 1 when a carry occurs, and cleared to 0 otherwise. Used by:

- Add instructions, to indicate a carry
- Subtract instructions, to indicate a borrow
- Shift and rotate instructions, to store the carry

The carry flag is also used as a bit accumulator by bit-manipulation instructions.

Some instructions leave some or all of the flag bits unchanged. For the action of each instruction on the flag bits, see appendix A.1, Instructions.

Operations can be performed on the CCR bits by the LDC, STC, ANDC, ORC, and XORC instructions. The N, Z, V, and C flags are used as branching conditions for conditional branch (Bcc) instructions.

### 2.4.4 Initial Register Values

Reset exception handling loads the CPU's program counter (PC) from the vector table, clears the trace bit in EXR to 0, and sets the interrupt mask bits in CCR and EXR to 1. The other CCR bits and the general registers are not initialized. In particular, the stack pointer (ER7) is not initialized. The stack pointer should therefore be initialized by an MOV.L instruction executed immediately after a reset.

## 2.5 Data Formats

The CPU can process 1-bit, 4-bit (BCD), 8-bit (byte), 16-bit (word), and 32-bit (longword) data. Bit-manipulation instructions operate on 1-bit data by accessing bit  $n$  ( $n = 0, 1, 2, \dots, 7$ ) of byte operand data. The DAA and DAS decimal-adjust instructions treat byte data as two digits of 4-bit BCD data.

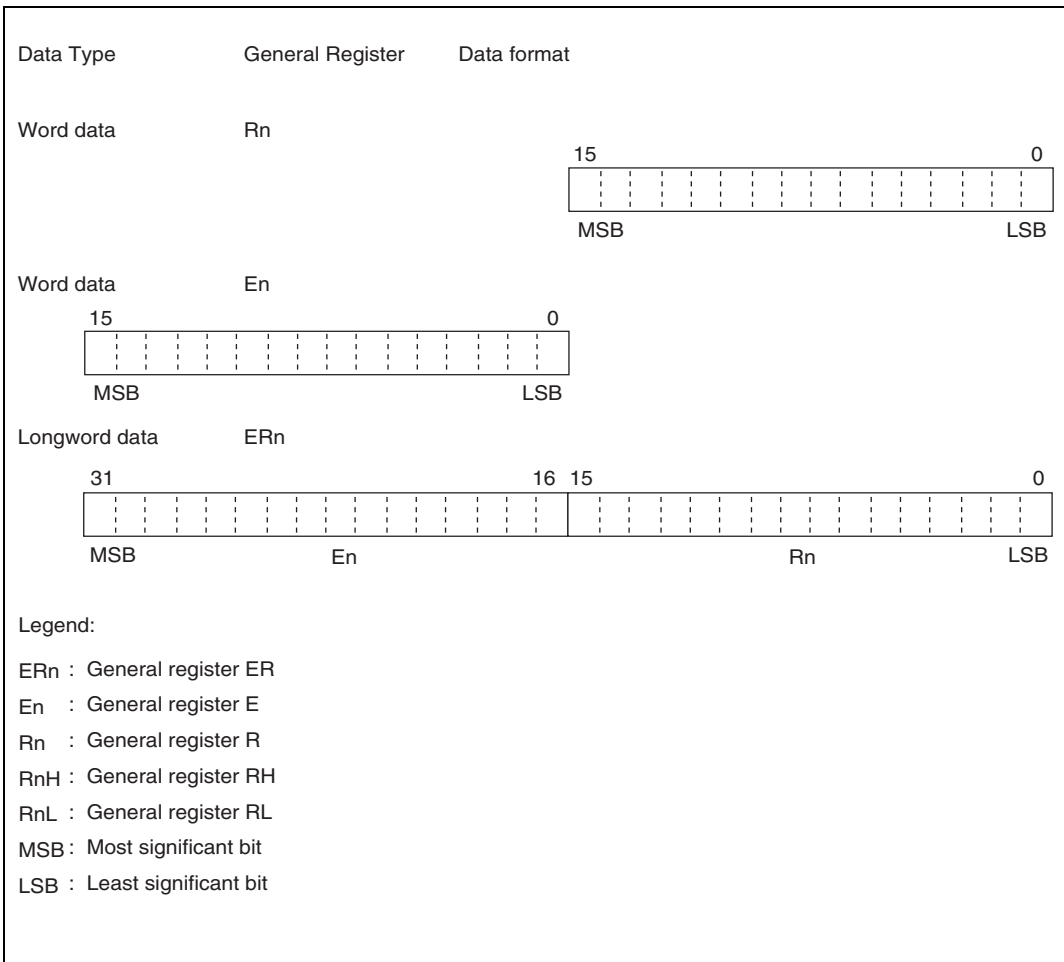


## 2.5.1 General Register Data Formats

Figure 2.10 shows the data formats in general registers.

Data type	General Register	Data Format
1-bit data	RnH	<p>7 0 7 6 5 4 3 2 1 0 Don't care</p>
1-bit data	RnL	<p>7 0 Don't care 7 6 5 4 3 2 1 0</p>
4-bit BCD data	RnH	<p>7 4 3 0 Upper digit Lower digit Don't care</p>
4-bit BCD data	RnL	<p>7 4 3 0 Don't care Upper digit Lower digit</p>
Byte data	RnH	<p>7 0 MSB LSB Don't care</p>
Byte data	RnL	<p>7 0 Don't care MSB LSB</p>

**Figure 2.10 General Register Data Formats (1)**

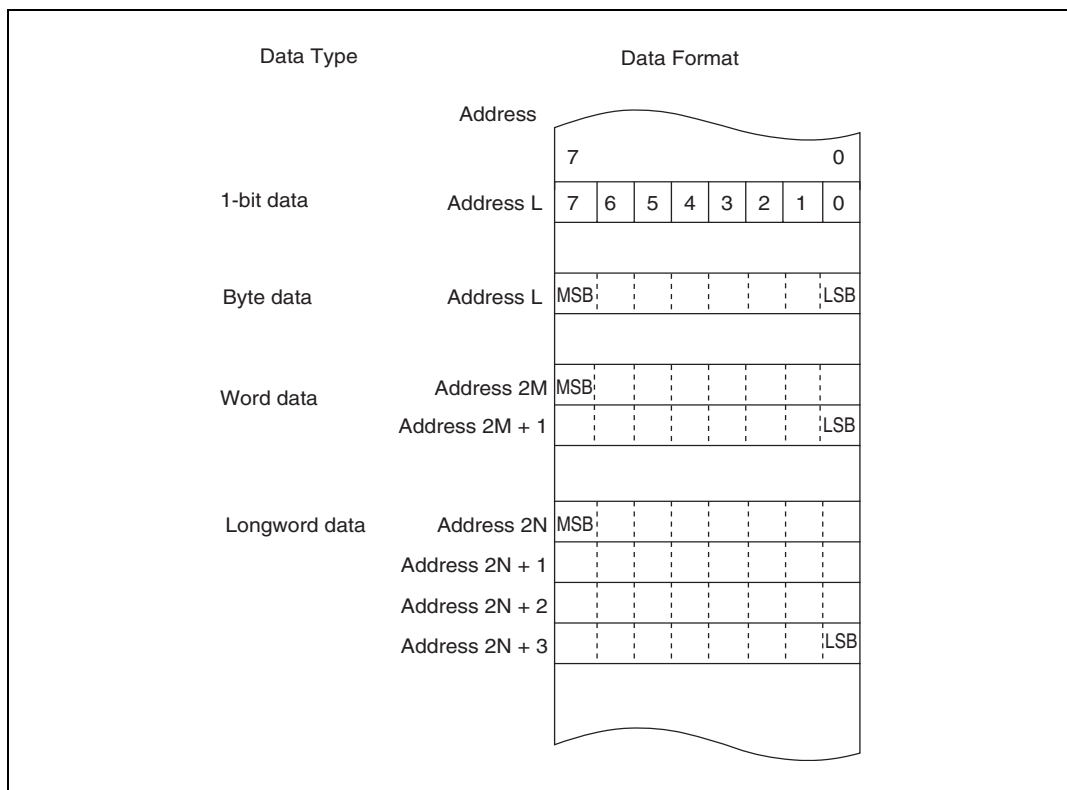


**Figure 2.10 General Register Data Formats (2)**

## 2.5.2 Memory Data Formats

Figure 2.11 shows the data formats in memory.

The CPU can access word data and longword data in memory, but word or longword data must begin at an even address. If an attempt is made to access word or longword data at an odd address, no address error occurs but the least significant bit of the address is regarded as 0, so the access starts at the preceding address. This also applies to instruction fetches.



**Figure 2.11 Memory Data Formats**

When ER7 (SP) is used as an address register to access the stack, the operand size should be word size or longword size.

## 2.6 Instruction Set

### 2.6.1 Overview

The H8S/2000 CPU has 65 types of instructions. The instructions are classified by function in table 2.1.

**Table 2.1 Instruction Classification**

Function	Instructions	Size	Types
Data transfer	MOV	BWL	5
	POP <sup>*1</sup> , PUSH <sup>*1</sup>	WL	
	LDM, STM	L	
	MOVFPE <sup>*3</sup> , MOVTPPE <sup>*3</sup>	B	
Arithmetic	ADD, SUB, CMP, NEG	BWL	19
	ADDX, SUBX, DAA, DAS	B	
	INC, DEC	BWL	
	ADDS, SUBS	L	
	MULXU, DIVXU, MULXS, DIVXS	BW	
	EXTU, EXTS	WL	
	TAS <sup>*4</sup>	B	
Logic operations	AND, OR, XOR, NOT	BWL	4
Shift	SHAL, SHAR, SHLL, SHLR, ROTL, ROTR, ROTXL, ROTXR	BWL	8
Bit manipulation	RSET, BCLR, BNOT, BTST, BLD, BILD, BST, BIST, BAND, BIAND, BOR, BIOR, BXOR, BIXOR	B	14
Branch	Bcc <sup>*2</sup> , JMP, BSR, JSR, RTS	—	5
System control	TRAPA, RTE, SLEEP, LDC, STC, ANDC, ORC, XORC, NOP	—	9
Block data transfer	EEPMOV	—	1

**Total: 65 types**

Legend:

B: Byte

W: Word

L: Longword

- Notes:
1. POP.W Rn and PUSH.W Rn are identical to MOV.W @SP+, Rn and MOV.W Rn, @-SP.  
POP.L ERn and PUSH.L ERn are identical to MOV.L @SP+, ERn and MOV.L ERn, @-SP.
  2. Bcc is the general name for conditional branch instructions.
  3. Not available in this LSI.
  4. Only register ER0, ER1, ER4, or ER5 should be used when using the TAS instruction.

## 2.6.2 Instructions and Addressing Modes

Table 2.2 indicates the combinations of instructions and addressing modes that the H8S/2000 CPU can use.

**Table 2.2 Combinations of Instructions and Addressing Modes**

Function	Instruction	Addressing Modes													
		#xx	Rn	@ERn	@(d:16, ERn)	@(d:32, ERn)	@-ERn/@ERn+	@aar8	@aar:16	@aar:24	@aa:32	@(d:8, PC)	@(d:16, PC)	@@aar:8	
Data transfer	MOV	BWL	BWL	BWL	BWL	BWL	BWL	B	BWL	—	BWL	—	—	—	—
	POP, PUSH	—	—	—	—	—	—	—	—	—	—	—	—	—	WL
	LDM, STM	—	—	—	—	—	—	—	—	—	—	—	—	—	L
	MOVFP, MOVTP <sup>1</sup>	—	—	—	—	—	—	—	B	—	—	—	—	—	—
Arithmetic operations	ADD, CMP	BWL	BWL	—	—	—	—	—	—	—	—	—	—	—	—
	SUB	WL	BWL	—	—	—	—	—	—	—	—	—	—	—	—
	ADDX, SUBX	B	B	—	—	—	—	—	—	—	—	—	—	—	—
	ADDS, SUBS	—	L	—	—	—	—	—	—	—	—	—	—	—	—
	INC, DEC	—	BWL	—	—	—	—	—	—	—	—	—	—	—	—
	DAA, DAS	—	B	—	—	—	—	—	—	—	—	—	—	—	—
	MULXU, DIVXU	—	BW	—	—	—	—	—	—	—	—	—	—	—	—
	MULXS, DIVXS	—	BW	—	—	—	—	—	—	—	—	—	—	—	—
	NEG	—	BWL	—	—	—	—	—	—	—	—	—	—	—	—
	EXTU, EXTS	—	WL	—	—	—	—	—	—	—	—	—	—	—	—
TAS <sup>2</sup>	—	—	B	—	—	—	—	—	—	—	—	—	—	—	
Logic operation	AND, OR, XOR	BWL	BWL	—	—	—	—	—	—	—	—	—	—	—	—
	NOT	—	BWL	—	—	—	—	—	—	—	—	—	—	—	—
Shift	—	BWL	—	—	—	—	—	—	—	—	—	—	—	—	
Bit manipulation	—	B	B	—	—	—	—	B	B	—	B	—	—	—	
Branch	Bcc, BSR	—	—	—	—	—	—	—	—	—	—	○	○	—	
	JMP, JSR	—	—	—	—	—	—	—	—	○	—	—	—	○	
	RTS	—	—	—	—	—	—	—	—	—	—	—	—	○	
System control	TRAPA	—	—	—	—	—	—	—	—	—	—	—	—	○	
	RTE	—	—	—	—	—	—	—	—	—	—	—	—	○	
	SLEEP	—	—	—	—	—	—	—	—	—	—	—	—	○	
	LDC	B	B	W	W	W	W	—	W	—	W	—	—	—	
	STC	—	B	W	W	W	W	—	W	—	W	—	—	—	
	ANDC, ORC, XORC	B	—	—	—	—	—	—	—	—	—	—	—	—	
	NOP	—	—	—	—	—	—	—	—	—	—	—	—	○	
Block data transfer	—	—	—	—	—	—	—	—	—	—	—	—	—	BW	

Legend:

B: Byte

W: Work

L: Longword

Notes: 1. Cannot be used in this LSI.

2. Only register ER0, ER1, ER4, or ER5 should be used when using the TAS instruction.

### 2.6.3 Table of Instructions Classified by Function

Table 2.3 to 2.10 summarize the instructions in each functional category. The notation used in table 2.3 is defined below.

#### Operation Notation

Rd	General register (destination)*
Rs	General register (source)*
Rn	General register*
ERn	General register (32-bit register)
(EAd)	Destination operand
(EAs)	Source operand
EXR	Extended control register
CCR	Condition-code register
N	N (negative) flag in CCR
Z	Z (zero) flag in CCR
V	V (overflow) flag in CCR
C	C (carry) flag in CCR
PC	Program counter
SP	Stack pointer
#IMM	Immediate data
Disp	Displacement
+	Addition
-	Subtraction
×	Multiplication
÷	Division
^	Logical AND
∨	Logical OR
⊕	Logical exclusive OR
→	Move
~	NOT (logical complement)
:8/:16/:24/:32	8-, 16-, 24-, or 32-bit length

Note: \* General registers include 8-bit registers (R0H to R7H, R0L to R7L), 16-bit registers (R0 to R7, E0 to E7), and 32-bit registers (ER0 to ER7).

**Table 2.3 Data Transfer Instructions**

<b>Instruction</b>	<b>Size*</b>	<b>Function</b>
MOV	B/W/L	(EAs) → Rd, Rs → (EAd) Moves data between two general registers or between a general register and memory, or moves immediate data to a general register
MOVFP	B	Cannot be used in this LSI
MOVTP	B	Cannot be used in this LSI
POP	W/L	@SP+ → Rn Pops a general register from the stack POP.W Rn is identical to MOV.W @SP+, Rn POP.L ERn is identical to MOV.L @SP+, ERn
PUSH	W/L	Rn → @-SP Pushes a general register onto the stack PUSH.W Rn is identical to MOV.W Rn, @-SP PUSH.L ERn is identical to MOV.L ERn, @-SP
LDM	L	@SP+ → Rn (register list) Pops two or more general registers from the stack
STM	L	Rn (register list) → @-SP Pushes two or more general registers onto the stack

Note: \* Size refers to the operand size.

B: Byte

W: Word

L: Longword



**Table 2.4 Arithmetic Instructions**

<b>Instruction</b>	<b>Size<sup>*1</sup></b>	<b>Function</b>
ADD SUB	B/W/L	$Rd \pm Rs \rightarrow Rd$ , $Rd \pm \#IMM \rightarrow Rd$ Performs addition or subtraction on data in two general registers, or on immediate data and data in a general register. (Immediate byte data cannot be subtracted from byte data in a general register. Use the SUBX or ADD instruction)
ADDX SUBX	B	$Rd \pm Rs \pm C \rightarrow Rd$ , $Rd \pm \#IMM \pm C \rightarrow Rd$ Performs addition or subtraction with carry on byte data in two general registers, or on immediate data and data in a general register
INC DEC	B/W/L	$Rd \pm 1 \rightarrow Rd$ , $Rd \pm 2 \rightarrow Rd$ Increments or decrements a general register by 1 or 2. (Byte operands can be incremented or decremented by 1 only)
ADDS SUBS	B	$Rd \pm 1 \rightarrow Rd$ , $Rd \pm 2 \rightarrow Rd$ , $Rd \pm 4 \rightarrow Rd$ Adds or subtracts the value 1, 2, or 4 to or from data in a 32-bit register
DAA DAS	B/W	$Rd$ decimal adjust $\rightarrow Rd$ Decimal-adjusts an addition or subtraction result in a general register by referring to the CCR to produce 4-bit BCD data
MULXU	B/W	$Rd \times Rs \rightarrow Rd$ Performs unsigned multiplication on data in two general registers: either 8 bits $\times$ 8 bits $\rightarrow$ 16 bits or 16 bits $\times$ 16 bits $\rightarrow$ 32 bits
MULXS	B/W	$Rd \times Rs \rightarrow Rd$ Performs signed multiplication on data in two general registers: either 8 bits $\times$ 8 bits $\rightarrow$ 16 bits or 16 bits $\times$ 16 bits $\rightarrow$ 32 bits
DIVXU	B/W	$Rd \div Rs \rightarrow Rd$ Performs unsigned division on data in two general registers: either 16 bits $\div$ 8 bits $\times$ 8-bit quotient and 8-bit remainder or 32 bits $\div$ 16 bits $\times$ 16-bit quotient and 16-bit remainder

Instruction	Size* <sup>1</sup>	Function
DIVXS	B/W	Rd $\div$ Rs $\rightarrow$ Rd  Performs signed division on data in two general registers: either 16 bits $\div$ 8 bits $\rightarrow$ 8-bit quotient and 8-bit remainder or 32 bits $\div$ 16 bits $\rightarrow$ 16-bit quotient and 16-bit remainder
CMP	B/W/L	Rd - Rs, Rd - #IMM  Compares data in a general register with data in another general register or with immediate data, and sets CCR bits according to the result
NEG	B/W/L	0 - Rd $\rightarrow$ Rd  Takes the two's complement (arithmetic complement) of data in a general register
EXTU	W/L	Rd (zero extension) $\rightarrow$ Rd  Extends the lower 8 bits of a 16-bit register to word size, or the lower 16 bits of a 32-bit register to longword size, by padding with zeros on the left
EXTS	W/L	Rd (sign extension) $\rightarrow$ Rd  Extends the lower 8 bits of a 16-bit register to word size, or the lower 16 bits of a 32-bit register to longword size, by extending the sign bit
TAS	B	@ERd - 0, 1 $\rightarrow$ (<bit 7> of @ERd) <sup>*2</sup>  Tests memory contents, and sets the most significant bit (bit 7) to 1

Notes: 1. Size refers to the operand size.

B: Byte

W: Word

L: Longword

2. Only register ER0, ER1, ER4, or ER5 should be used when using the TAS instruction.

**Table 2.5 Logic Instructions**

<b>Instruction</b>	<b>Size*</b>	<b>Function</b>
AND	B/W/L	$Rd \wedge Rs \rightarrow Rd$ , $Rd \wedge \#IMM \rightarrow Rd$ Performs a logical AND operation on a general register and another general register or immediate data
OR	B/W/L	$Rd \vee Rs \rightarrow Rd$ , $Rd \vee \#IMM \rightarrow Rd$ Performs a logical OR operation on a general register and another general register or immediate data
XOR	B/W/L	$Rd \oplus Rs \rightarrow Rd$ , $Rd \oplus \#IMM \rightarrow Rd$ Performs a logical exclusive OR operation on a general register and another general register or immediate data
NOT	B/W/L	$\sim Rd \rightarrow Rd$ Takes the one's complement (logical complement) of general register contents

Note: \* Size refers to the operand size.

B: Byte

W: Word

L: Longword

**Table 2.6 Shift Instructions**

<b>Instruction</b>	<b>Size*</b>	<b>Function</b>
SHAL SHAR	B/W/L	$Rd \text{ (shift)} \rightarrow Rd$ Performs an arithmetic shift on general register contents A 1-bit or 2-bit shift is possible
SHLL SHLR	B/W/L	$Rd \text{ (shift)} \rightarrow Rd$ Performs a logical shift on general register contents A 1-bit or 2-bit shift is possible
ROTL ROTR	B/W/L	$Rd \text{ (rotate)} \rightarrow Rd$ Rotates general register contents 1-bit or 2-bit rotation is possible
ROTXL ROTXR	B/W/L	$Rd \text{ (rotate)} \rightarrow Rd$ Rotates general register contents through the carry flag 1-bit or 2-bit rotation is possible

Note: \* Size refers to the operand size.

B: Byte

W: Word

L: Longword

**Table 2.7 Bit Manipulation Instructions**

<b>Instruction</b>	<b>Size*</b>	<b>Function</b>
BSET	B	$1 \rightarrow (\text{<bit-No.> of <EAd>})$ Sets a specified bit in a general register or memory operand to 1. The bit number is specified by 3-bit immediate data or the lower three bits of a general register
BCLR	B	$0 \rightarrow (\text{<bit-No.> of <EAd>})$ Clears a specified bit in a general register or memory operand to 0. The bit number is specified by 3-bit immediate data or the lower three bits of a general register
BNOT	B	$\sim (\text{<bit-No.> of <EAd>}) \rightarrow (\text{<bit-No.> of <EAd>})$ Inverts a specified bit in a general register or memory operand. The bit number is specified by 3-bit immediate data or the lower three bits of a general register
BTST	B	$\sim (\text{<bit-No.> of <EAd>}) \rightarrow Z$ Tests a specified bit in a general register or memory operand and sets or clears the Z flag accordingly. The bit number is specified by 3-bit immediate data or the lower three bits of a general register
BAND	B	$C \wedge (\text{<bit-No.> of <EAd>}) \rightarrow C$ ANDs the carry flag with a specified bit in a general register or memory operand and stores the result in the carry flag
BIAND	B	$C \wedge [\sim(\text{<bit-No.> of <EAd>})] \rightarrow C$ ANDs the carry flag with the inverse of a specified bit in a general register or memory operand and stores the result in the carry flag The bit number is specified by 3-bit immediate data
BOR	B	$C \vee (\text{<bit-No.> of <EAd>}) \rightarrow C$ ORs the carry flag with a specified bit in a general register or memory operand and stores the result in the carry flag
BIOR	B	$C \vee [\sim(\text{<bit-No.> of <EAd>})] \rightarrow C$ ORs the carry flag with the inverse of a specified bit in a general register or memory operand and stores the result in the carry flag The bit number is specified by 3-bit immediate data

<b>Instruction</b>	<b>Size*</b>	<b>Function</b>
BOXR	B	$C \oplus (\text{<bit-No.> of <EAd>}) \rightarrow C$ Exclusive-ORs the carry flag with a specified bit in a general register or memory operand and stores the result in the carry flag
BIXOR	B	$C \oplus [\sim (\text{<bit-No.> of <EAd>})] \rightarrow C$ Exclusive-ORs the carry flag with the inverse of a specified bit in a general register or memory operand and stores the result in the carry flag The bit number is specified by 3-bit immediate data
BLD	B	$(\text{<bit-No.> of <EAd>}) \rightarrow C$ Transfers a specified bit in a general register or memory operand to the carry flag
BILD	B	$\sim (\text{<bit-No.> of <EAd>}) \rightarrow C$ Transfers the inverse of a specified bit in a general register or memory operand to the carry flag The bit number is specified by 3-bit immediate data
BST	B	$C \rightarrow (\text{<bit-No.> of <EAd>})$ Transfers the carry flag value to a specified bit in a general register or memory operand
BIST	B	$\sim C \rightarrow (\text{<bit-No.> of <EAd>})$ Transfers the inverse of the carry flag value to a specified bit in a general register or memory operand The bit number is specified by 3-bit immediate data

Note: \* Size refers to the operand size.

B: Byte

**Table 2.8 Branch Instructions**

<b>Instruction</b>	<b>Size*</b>	<b>Function</b>																																																			
Bcc	—	Branches to a specified address if a specified condition is true The branching conditions are listed below																																																			
		<table border="1"> <thead> <tr> <th><b>Mnemonic</b></th> <th><b>Description</b></th> <th><b>Condition</b></th> </tr> </thead> <tbody> <tr> <td>BRA (BT)</td> <td>Always (True)</td> <td>Always</td> </tr> <tr> <td>BRN (BF)</td> <td>Never (False)</td> <td>Never</td> </tr> <tr> <td>BHI</td> <td>High</td> <td>CVZ = 0</td> </tr> <tr> <td>BLS</td> <td>Low of Same</td> <td>CVZ = 1</td> </tr> <tr> <td>BCC (BHS)</td> <td>Carry Clear (High or Same)</td> <td>C = 0</td> </tr> <tr> <td>BCS (BLO)</td> <td>Carry Set (LOW)</td> <td>C = 1</td> </tr> <tr> <td>BNE</td> <td>Not Equal</td> <td>Z = 0</td> </tr> <tr> <td>BEQ</td> <td>Equal</td> <td>Z = 1</td> </tr> <tr> <td>BVC</td> <td>oVerflow Clear</td> <td>V = 0</td> </tr> <tr> <td>BVS</td> <td>oVerflow Set</td> <td>V = 1</td> </tr> <tr> <td>BPL</td> <td>PLus</td> <td>N = 0</td> </tr> <tr> <td>BMI</td> <td>MInus</td> <td>N = 1</td> </tr> <tr> <td>BGE</td> <td>Greater or Equal</td> <td>NV = 0</td> </tr> <tr> <td>BLT</td> <td>Less Than</td> <td><math>N \oplus V = 1</math></td> </tr> <tr> <td>BGT</td> <td>Greater Than</td> <td><math>Z \vee (N \oplus V) = 0</math></td> </tr> <tr> <td>BLE</td> <td>Less or Equal</td> <td><math>Z \vee (N \oplus V) = 1</math></td> </tr> </tbody> </table>	<b>Mnemonic</b>	<b>Description</b>	<b>Condition</b>	BRA (BT)	Always (True)	Always	BRN (BF)	Never (False)	Never	BHI	High	CVZ = 0	BLS	Low of Same	CVZ = 1	BCC (BHS)	Carry Clear (High or Same)	C = 0	BCS (BLO)	Carry Set (LOW)	C = 1	BNE	Not Equal	Z = 0	BEQ	Equal	Z = 1	BVC	oVerflow Clear	V = 0	BVS	oVerflow Set	V = 1	BPL	PLus	N = 0	BMI	MInus	N = 1	BGE	Greater or Equal	NV = 0	BLT	Less Than	$N \oplus V = 1$	BGT	Greater Than	$Z \vee (N \oplus V) = 0$	BLE	Less or Equal	$Z \vee (N \oplus V) = 1$
<b>Mnemonic</b>	<b>Description</b>	<b>Condition</b>																																																			
BRA (BT)	Always (True)	Always																																																			
BRN (BF)	Never (False)	Never																																																			
BHI	High	CVZ = 0																																																			
BLS	Low of Same	CVZ = 1																																																			
BCC (BHS)	Carry Clear (High or Same)	C = 0																																																			
BCS (BLO)	Carry Set (LOW)	C = 1																																																			
BNE	Not Equal	Z = 0																																																			
BEQ	Equal	Z = 1																																																			
BVC	oVerflow Clear	V = 0																																																			
BVS	oVerflow Set	V = 1																																																			
BPL	PLus	N = 0																																																			
BMI	MInus	N = 1																																																			
BGE	Greater or Equal	NV = 0																																																			
BLT	Less Than	$N \oplus V = 1$																																																			
BGT	Greater Than	$Z \vee (N \oplus V) = 0$																																																			
BLE	Less or Equal	$Z \vee (N \oplus V) = 1$																																																			
JMP	—	Branches unconditionally to a specified address																																																			
BSR	—	Branches to a subroutine at a specified address																																																			
JSR	—	Branches to a subroutine at a specified address																																																			
RTS	—	Returns from a subroutine																																																			

**Table 2.9 System Control Instructions**

<b>Instruction</b>	<b>Size*</b>	<b>Function</b>
TRAPA	—	Starts trap-instruction exception handling
RTE	—	Returns from an exception-handling routine
SLEEP	—	Causes a transition to a power-down state
LDC	B/W	(EAs) → CCR, (EAs) → EXR Moves contents of a general register or memory or immediate data to CCR or EXR. Although CCR and EXR are 8-bit registers, word-size transfers are performed between them and memory. The upper 8 bits are valid
STC	B/W	CCR → (EAd), EXR → (EAd) Transfers CCR or EXR contents to a general register or memory. Although CCR and EXR are 8-bit registers, word-size transfers are performed between them and memory. The upper 8 bits are valid
ANDC	B	CCR ∧ #IMM → CCR, EXR ∧ #IMM → EXR Logically ANDs the CCR or EXR contents with immediate data
ORC	B	CCR ∨ #IMM → CCR, EXR ∨ #IMM → EXR Logically ORs the CCR or EXR contents with immediate data
XORC	B	CCR ⊕ #IMM → CCR, EXR ⊕ #IMM → EXR Logically exclusive-ORs the CCR or EXR contents with immediate data
NOP	—	PC + 2 → PC Only increments the program counter

Note: \* Size refers to the operand size.

B: Byte  
W: Word

**Table 2.10 Block Data Transfer Instructions**

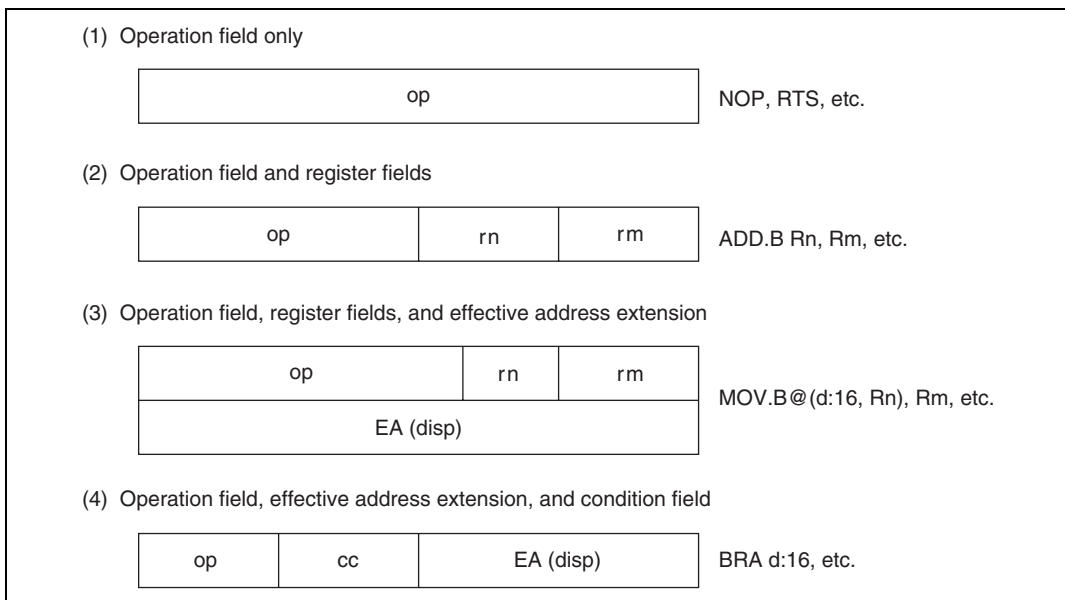
<b>Instruction</b>	<b>Size*</b>	<b>Function</b>
EEPMOV.B	—	if R4L $\neq$ 0 then Repeat @ER5+ $\rightarrow$ @ER6+ R4L-1 $\rightarrow$ R4L Until R4L = 0 else next;
EEPMOV.W	—	if R4 $\neq$ 0 then Repeat @ER5+ $\rightarrow$ @ER6+ R4-1 $\rightarrow$ R4 Until R4 = 0 else next; Transfers a data block according to parameters set in general registers R4L or R4, ER5, and ER6 R4L or R4: size of block (bytes) ER5: starting source address ER6: starting destination address Execution of the next instruction begins as soon as the transfer is completed



## 2.6.4 Basic Instruction Formats

The CPU instructions consist of 2-byte (1-word) units. An instruction consists of an operation field (op field), a register field (r field), an effective address extension (EA field), and a condition field (cc).

Figure 2.12 shows examples of instruction formats.



**Figure 2.12 Instruction Formats (Examples)**

**Operation Field:** Indicates the function of the instruction, the addressing mode, and the operation to be carried out on the operand. The operation field always includes the first four bits of the instruction. Some instructions have two operation fields.

**Register Field:** Specifies a general register. Address registers are specified by 3 bits, data registers by 3 bits or 4 bits. Some instructions have two register fields. Some have no register field.

**Effective Address Extension:** 8, 16, or 32 bits specifying immediate data, an absolute address, or a displacement.

**Condition Field:** Specifies the branching condition of Bcc instructions.

## 2.6.5 Notes on Use of Bit-Manipulation Instructions

The BSET, BCLR, BNOT, BST, and BIST instructions read a byte of data, carry out bit manipulation, then write back the byte of data. Caution is therefore required when using these instructions on a register containing write-only bits, or a port.

The BCLR instruction can be used to clear internal I/O register flags to 0. In this case, the relevant flag need not be read beforehand if it is clear that it has been set to 1 in an interrupt handling routine, etc.

## 2.7 Addressing Modes and Effective Address Calculation

### 2.7.1 Addressing Mode

The CPU supports the eight addressing modes listed in table 2.11. Each instruction uses a subset of these addressing modes. Arithmetic and logic instructions can use the register direct and immediate modes. Data transfer instructions can use all addressing modes except program-counter relative and memory indirect. Bit-manipulation instructions use register direct, register indirect, or absolute addressing mode to specify an operand, and register direct (BSET, BCLR, BNOT, and BTST instructions) or immediate (3-bit) addressing mode to specify a bit number in the operand.

**Table 2.11 Addressing Modes**

No.	Addressing Mode	Symbol
1	Register direct	Rn
2	Register indirect	@ERn
3	Register indirect with displacement	@(d:16,ERn)/@(d:32,ERn)
4	Register indirect with post-increment Register indirect with pre-decrement	@ERn+ @-ERn
5	Absolute address	@aa:8/#@aa:16/@aa:24/@aa:32
6	Immediate	#xx:8/#xx:16/#xx:32
7	Program-counter relative	@(d:8,PC)/@(d:16,PC)
8	Memory indirect	@@aa:8

#### (1) Register Direct—Rn

The register field of the instruction code specifies an 8-, 16-, or 32-bit general register containing the operand. R0H to R7H and R0L to R7L can be specified as 8-bit registers. R0 to R7 and E0 to E7 can be specified as 16-bit registers. ER0 to ER7 can be specified as 32-bit registers.

**(2) Register Indirect—@ERn**

The register field of the instruction code specifies an address register (ERn) which contains the address of the operand in memory. If the address is a program instruction address, the lower 24 bits are valid and the upper 8 bits are all assumed to be 0 (H'00).

**(3) Register Indirect with Displacement—@(d:16, ERn) or @(d:32, ERn)**

A 16-bit or 32-bit displacement contained in the instruction is added to an address register (ERn) specified by the register field of the instruction, and the sum gives the address of a memory operand. A 16-bit displacement is sign-extended when added.

**(4) Register Indirect with Post-Increment or Pre-Decrement—@ERn+ or @-ERn**

- Register indirect with post-increment—@ERn+  
The register field of the instruction code specifies an address register (ERn) which contains the address of a memory operand. After the operand is accessed, 1, 2, or 4 is added to the address register contents and the sum is stored in the address register. The value added is 1 for byte access, 2 for word access, or 4 for longword access. For word or longword access, the register value should be even.
- Register indirect with pre-decrement—@-ERn  
The value 1, 2, or 4 is subtracted from an address register (ERn) specified by the register field in the instruction code, and the result becomes the address of a memory operand. The result is also stored in the address register. The value subtracted is 1 for byte access, 2 for word access, or 4 for longword access. For word or longword access, the register value should be even.

**(5) Absolute Address—@aa:8, @aa:16, @aa:24, or @aa:32**

The instruction code contains the absolute address of a memory operand. The absolute address may be 8 bits long (@aa:8), 16 bits long (@aa:16), 24 bits long (@aa:24), or 32 bits long (@aa:32).

To access data, the absolute address should be 8 bits (@aa:8), 16 bits (@aa:16), or 32 bits (@aa:32) long. For an 8-bit absolute address, the upper 24 bits are all assumed to be 1 (H'FFFF). For a 16-bit absolute address the upper 16 bits are a sign extension. A 32-bit absolute address can access the entire address space.

A 24-bit absolute address (@aa:24) indicates the address of a program instruction. The upper 8 bits are all assumed to be 0 (H'00).

Table 2.12 indicates the accessible absolute address ranges.

**Table 2.12 Absolute Address Access Ranges**

<b>Absolute Address</b>		<b>Normal Mode</b>	<b>Advanced Mode</b>
Data address	8 bits (@aa:8)	H'FF00 to H'FFFF	H'FFFF00 to H'FFFFFF
	16 bits (@aa:16)	H'0000 to H'FFFF	H'000000 to H'007FFF, H'FF8000 to H'FFFFFF
	32 bits (@aa:32)		H'000000 to H'FFFFFF
Program instruction address	24 bits (@aa:24)		

**(6) Immediate—#xx:8, #xx:16, or #xx:32**

The instruction contains 8-bit (#xx:8), 16-bit (#xx:16), or 32-bit (#xx:32) immediate data as an operand.

The ADDS, SUBS, INC, and DEC instructions contain immediate data implicitly. Some bit manipulation instructions contain 3-bit immediate data in the instruction code, specifying a bit number. The TRAPA instruction contains 2-bit immediate data in its instruction code, specifying a vector address.

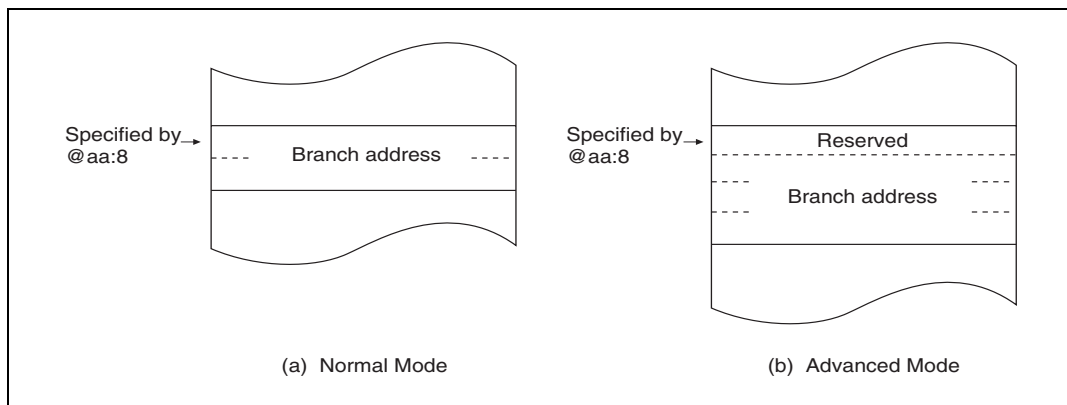
**(7) Program-Counter Relative—@(d:8, PC) or @(d:16, PC)**

This mode is used in the Bcc and BSR instructions. An 8-bit or 16-bit displacement contained in the instruction is sign-extended and added to the 24-bit PC contents to generate a branch address. Only the lower 24 bits of this branch address are valid; the upper 8 bits are all assumed to be 0 (H'00). The PC value to which the displacement is added is the address of the first byte of the next instruction, so the possible branching range is -126 to +128 bytes (-63 to +64 words) or -32766 to +32768 bytes (-16383 to +16384 words) from the branch instruction. The resulting value should be an even number.

**(8) Memory Indirect—@@aa:8**

This mode can be used by the JMP and JSR instructions. The instruction code contains an 8-bit absolute address specifying a memory operand. This memory operand contains a branch address. The upper bits of the absolute address are all assumed to be 0, so the address range is 0 to 255 (H'0000 to H'00FF in normal mode, H'000000 to H'0000FF in advanced mode). In normal mode the memory operand is a word operand and the branch address is 16 bits long. In advanced mode the memory operand is a longword operand, the first byte of which is assumed to be all 0 (H'00).

Note that the first part of the address range is also the exception vector area. For further details, see section 5, Exception Handling.



**Figure 2.13 Branch Address Specification in Memory Indirect Mode**

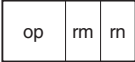
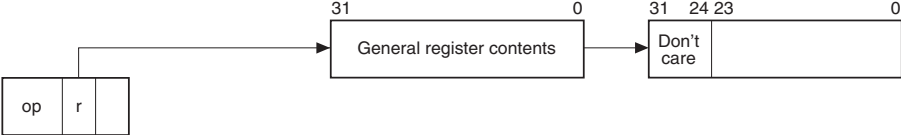
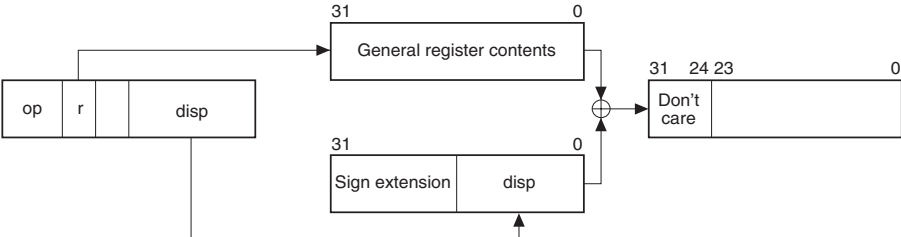
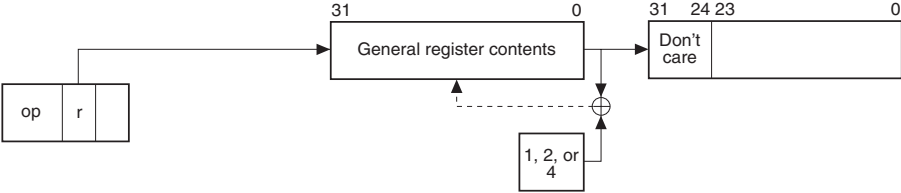
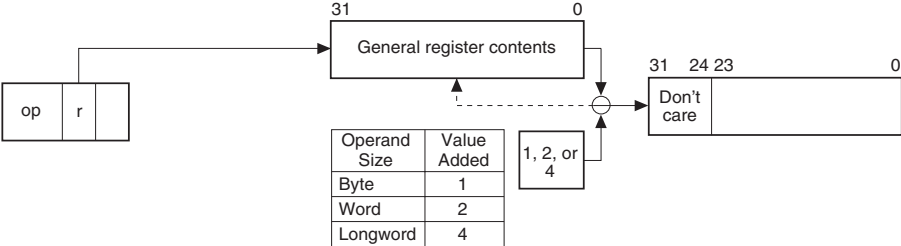
If an odd address is specified in word or longword memory access, or as a branch address, the least significant bit is regarded as 0, causing data to be accessed or an instruction code to be fetched at the address preceding the specified address. (For further information, see section 2.5.2, Memory Data Formats.)

## 2.7.2 Effective Address Calculation

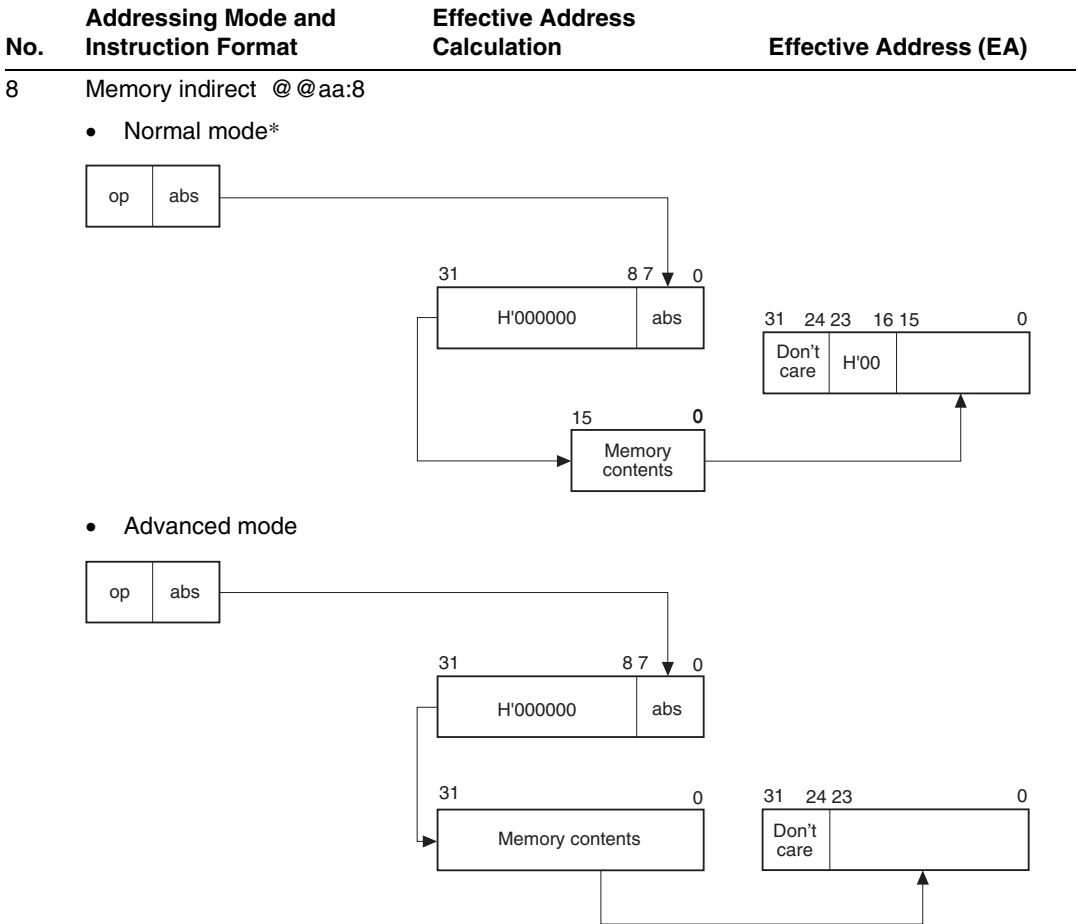
Table 2.13 indicates how effective addresses are calculated in each addressing mode.

In normal mode the upper 8 bits of the effective address are ignored in order to generate a 16-bit address.

Table 2.13 Effective Address Calculation

No.	Addressing Mode and Instruction Format	Effective Address Calculation	Effective Address (EA)								
1	Register direct (Rn) 		Operand is general register contents								
2	Register indirect (@ERn)										
3	Register indirect with displacement @(d:16, ERn) or @(d:32, ERn)										
4	Register indirect with post-increment or pre-decrement	<ul style="list-style-type: none"> <li>Register indirect with post-increment @ERn+ </li> <li>Register indirect with pre-decrement @-ERn </li> </ul> <table border="1" data-bbox="476 1310 648 1426"> <thead> <tr> <th>Operand Size</th> <th>Value Added</th> </tr> </thead> <tbody> <tr> <td>Byte</td> <td>1</td> </tr> <tr> <td>Word</td> <td>2</td> </tr> <tr> <td>Longword</td> <td>4</td> </tr> </tbody> </table>	Operand Size	Value Added	Byte	1	Word	2	Longword	4	
Operand Size	Value Added										
Byte	1										
Word	2										
Longword	4										

No.	Addressing Mode and Instruction Format	Effective Address Calculation	Effective Address (EA)																																																	
5	Absolute address	<p data-bbox="161 185 217 210">@aa:8</p> <div data-bbox="161 225 296 288"> <table border="1"> <tr> <td data-bbox="161 225 229 288">op</td> <td data-bbox="229 225 296 288">abs</td> </tr> </table> </div> <p data-bbox="161 344 217 370">@aa:16</p> <div data-bbox="161 384 426 448"> <table border="1"> <tr> <td data-bbox="161 384 296 448">op</td> <td data-bbox="296 384 426 448">abs</td> </tr> </table> </div> <p data-bbox="161 504 217 529">@aa:24</p> <div data-bbox="161 544 426 608"> <table border="1"> <tr> <td data-bbox="161 544 229 608">op</td> <td data-bbox="229 544 426 608">abs</td> </tr> </table> </div> <p data-bbox="161 671 217 697">@aa:32</p> <div data-bbox="161 711 426 839"> <table border="1"> <tr> <td data-bbox="161 711 296 775">op</td> <td data-bbox="296 711 426 839" rowspan="2">abs</td> </tr> <tr> <td data-bbox="161 775 296 839"></td> </tr> </table> </div>	op	abs	op	abs	op	abs	op	abs		<div data-bbox="828 185 1100 280"> <table border="1"> <tr> <td data-bbox="828 185 896 210">31</td> <td data-bbox="896 185 965 210">24</td> <td data-bbox="965 185 1034 210">23</td> <td data-bbox="1034 185 1100 210">8</td> <td data-bbox="1100 185 1169 210">7</td> <td data-bbox="1169 185 1204 210">0</td> </tr> <tr> <td colspan="2" data-bbox="828 225 896 280">Don't care</td> <td colspan="2" data-bbox="896 225 965 280">H'FFFF</td> <td colspan="2" data-bbox="965 225 1100 280"></td> </tr> </table> </div> <div data-bbox="828 360 1100 456"> <table border="1"> <tr> <td data-bbox="828 360 896 386">31</td> <td data-bbox="896 360 965 386">24</td> <td data-bbox="965 360 1034 386">23</td> <td data-bbox="1034 360 1100 386">16</td> <td data-bbox="1100 360 1169 386">15</td> <td data-bbox="1169 360 1204 386">0</td> </tr> <tr> <td colspan="2" data-bbox="828 392 896 448">Don't care</td> <td colspan="2" data-bbox="896 392 965 448">Sign extension</td> <td colspan="2" data-bbox="965 392 1100 448"></td> </tr> </table> </div> <div data-bbox="828 520 1100 616"> <table border="1"> <tr> <td data-bbox="828 520 896 545">31</td> <td data-bbox="896 520 965 545">24</td> <td data-bbox="965 520 1100 545">23</td> <td data-bbox="1100 520 1169 545">0</td> </tr> <tr> <td colspan="2" data-bbox="828 552 896 608">Don't care</td> <td colspan="2" data-bbox="896 552 1100 608"></td> </tr> </table> </div> <div data-bbox="828 743 1100 839"> <table border="1"> <tr> <td data-bbox="828 743 896 769">31</td> <td data-bbox="896 743 965 769">24</td> <td data-bbox="965 743 1100 769">23</td> <td data-bbox="1100 743 1169 769">0</td> </tr> <tr> <td colspan="2" data-bbox="828 775 896 831">Don't care</td> <td colspan="2" data-bbox="896 775 1100 831"></td> </tr> </table> </div>	31	24	23	8	7	0	Don't care		H'FFFF				31	24	23	16	15	0	Don't care		Sign extension				31	24	23	0	Don't care				31	24	23	0	Don't care			
op	abs																																																			
op	abs																																																			
op	abs																																																			
op	abs																																																			
31	24	23	8	7	0																																															
Don't care		H'FFFF																																																		
31	24	23	16	15	0																																															
Don't care		Sign extension																																																		
31	24	23	0																																																	
Don't care																																																				
31	24	23	0																																																	
Don't care																																																				
6	Immediate #xx:8/#xx:16/#xx:32	<table border="1"> <tr> <td data-bbox="161 927 296 991">op</td> <td data-bbox="296 927 426 991">IMM</td> </tr> </table>	op	IMM	Operand is immediate data																																															
op	IMM																																																			
7	Program-counter relative @(d:8, PC)/@(d:16, PC)	<table border="1"> <tr> <td data-bbox="161 1241 296 1305">op</td> <td data-bbox="296 1241 426 1305">disp</td> </tr> </table>	op	disp	<div data-bbox="575 1090 775 1177"> <table border="1"> <tr> <td data-bbox="575 1090 644 1117">23</td> <td data-bbox="644 1090 775 1117">0</td> </tr> <tr> <td colspan="2" data-bbox="575 1123 775 1177">PC contents</td> </tr> </table> </div> <div data-bbox="575 1273 775 1361"> <table border="1"> <tr> <td data-bbox="575 1273 644 1299">23</td> <td data-bbox="644 1273 775 1299">0</td> </tr> <tr> <td data-bbox="575 1305 644 1361">Sign extension</td> <td data-bbox="644 1305 775 1361">disp</td> </tr> </table> </div> <div data-bbox="828 1313 1100 1406"> <table border="1"> <tr> <td data-bbox="828 1313 896 1339">31</td> <td data-bbox="896 1313 965 1339">24</td> <td data-bbox="965 1313 1100 1339">23</td> <td data-bbox="1100 1313 1169 1339">0</td> </tr> <tr> <td colspan="2" data-bbox="828 1345 896 1401">Don't care</td> <td colspan="2" data-bbox="896 1345 1100 1401"></td> </tr> </table> </div>	23	0	PC contents		23	0	Sign extension	disp	31	24	23	0	Don't care																																		
op	disp																																																			
23	0																																																			
PC contents																																																				
23	0																																																			
Sign extension	disp																																																			
31	24	23	0																																																	
Don't care																																																				



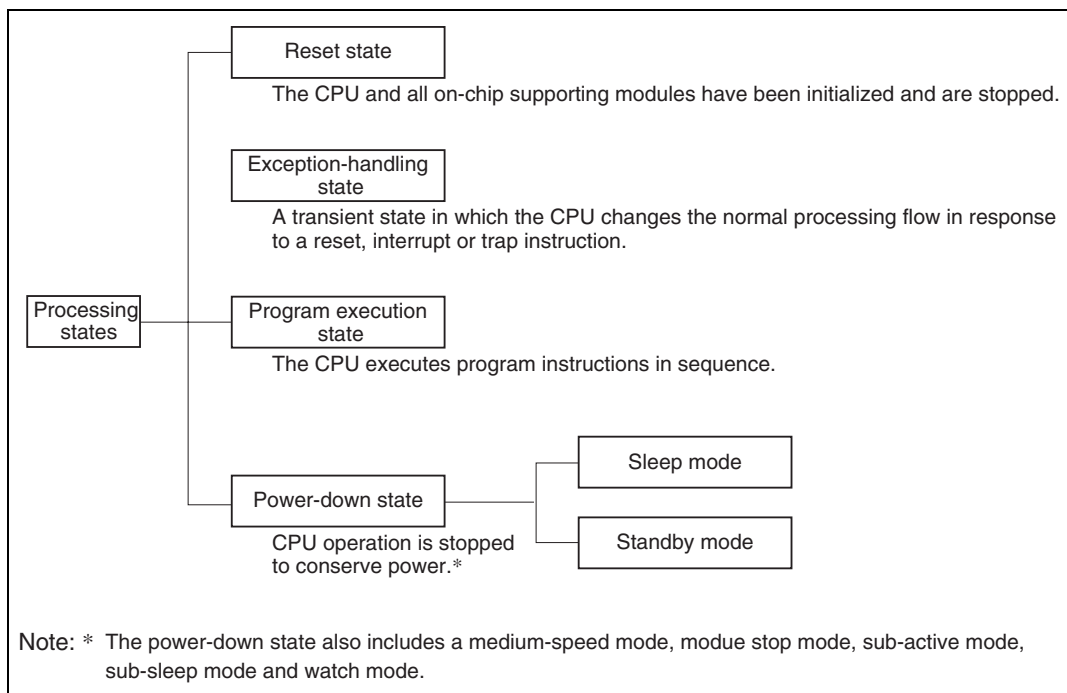
Note: \* Not available in this LSI.



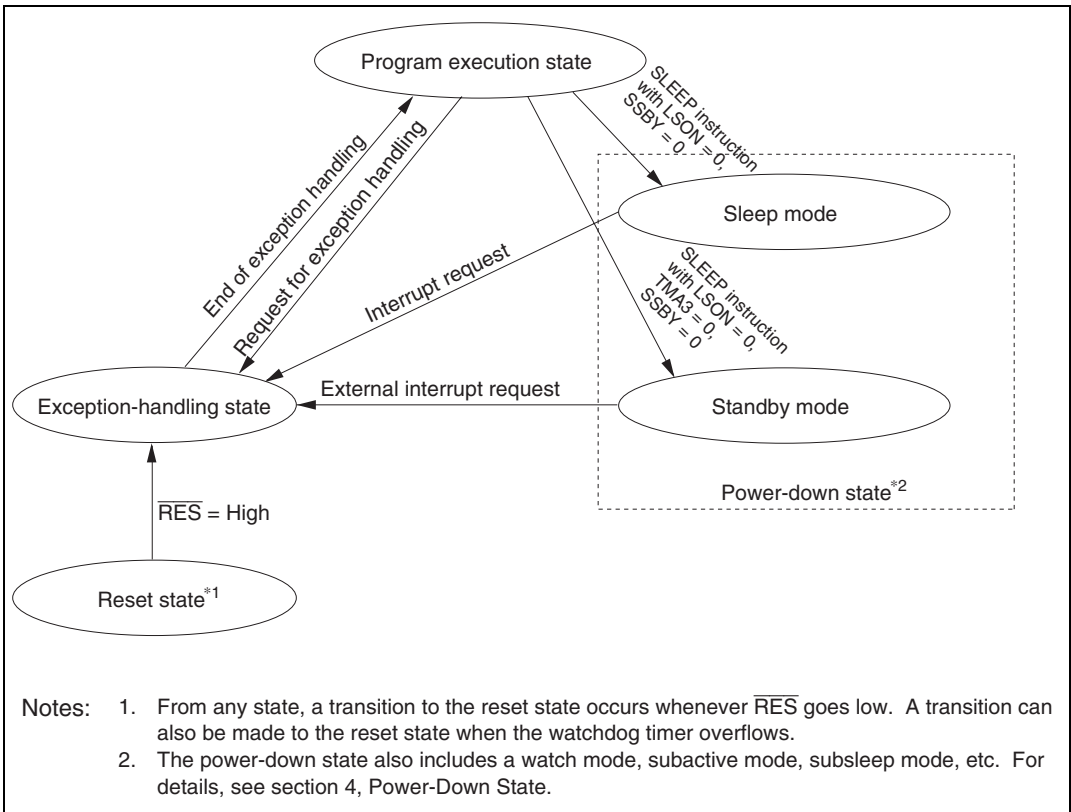
## 2.8 Processing States

### 2.8.1 Overview

The CPU has four main processing states: the reset state, exception-handling state, program execution state, and power-down state. Figure 2.14 shows a diagram of the processing states. Figure 2.15 indicates the state transitions.



**Figure 2.14 Processing States**



- Notes:
1. From any state, a transition to the reset state occurs whenever  $\overline{\text{RES}}$  goes low. A transition can also be made to the reset state when the watchdog timer overflows.
  2. The power-down state also includes a watch mode, subactive mode, subsleep mode, etc. For details, see section 4, Power-Down State.

**Figure 2.15 State Transitions**

## 2.8.2 Reset State

When the  $\overline{\text{RES}}$  input goes low all current processing stops and the CPU enters the reset state. All interrupts are disabled in the reset state. Reset exception handling starts when the  $\overline{\text{RES}}$  signal changes from low to high.

The reset state can also be entered by a watchdog timer overflow. For details, see section 18, Watchdog Timer (WDT).

### 2.8.3 Exception-Handling State


The exception-handling state is a transient state that occurs when the CPU alters the normal processing flow due to a reset, interrupt, or trap instruction. The CPU fetches a start address (vector) from the exception vector table and branches to that address.

#### (1) Types of Exception Handling and Their Priority

Exception handling is performed for resets, interrupts, and trap instructions. Table 2.14 indicates the types of exception handling and their priority. Trap instruction exception handling is always accepted in the program execution state.

Exception handling and the stack structure depend on the interrupt control mode set in SYSCR.

**Table 2.14 Exception Handling Types and Priority**

Priority	Type of Exception	Detection Timing	Start of Exception Handling
 High	Reset	Synchronized with clock	Exception handling starts immediately after a low-to-high transition at the $\overline{\text{RES}}$ pin, or when the watchdog timer overflows
	Interrupt	End of instruction execution or end of exception-handling sequence <sup>*1</sup>	When an interrupt is requested, exception handling starts at the end of the current instruction or current exception-handling sequence
	Trap instruction	When TRAPA instruction is executed	Exception handling starts when a trap (TRAPA) instruction is executed <sup>*2</sup>
Low			

Notes: 1. Interrupts are not detected at the end of the ANDC, ORC, XORC, and LDC instructions, or immediately after reset exception handling.

2. Trap instruction exception handling is always accepted in the program execution state.

#### (2) Reset Exception Handling

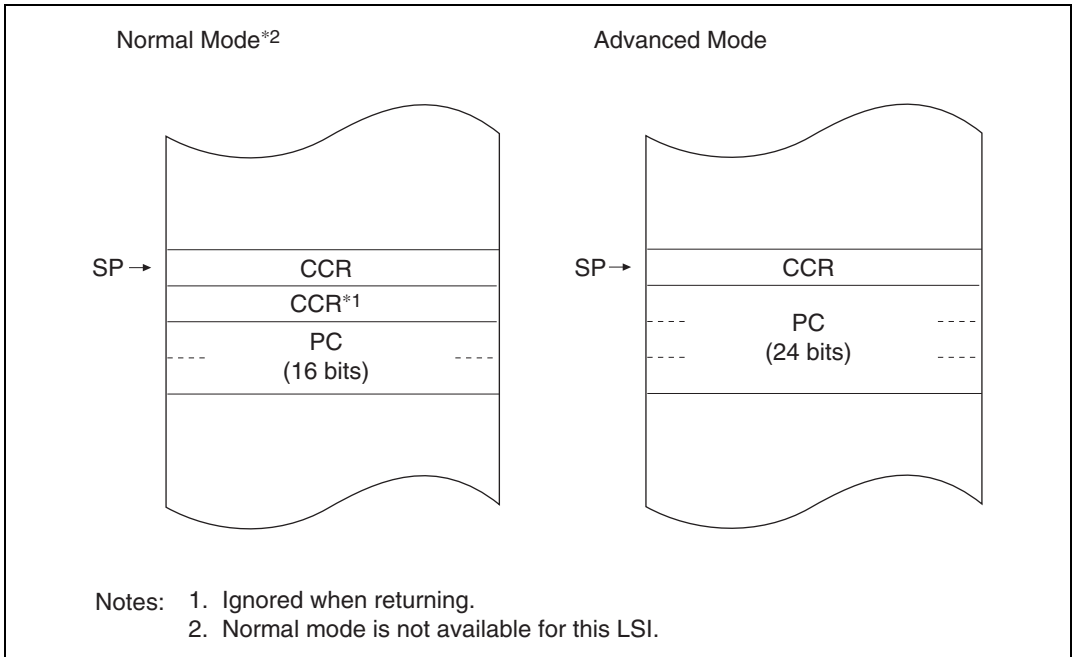
After the  $\overline{\text{RES}}$  pin has gone low and the reset state has been entered, when  $\overline{\text{RES}}$  goes high again, reset exception handling starts. When reset exception handling starts the CPU fetches a start address (vector) from the exception vector table and starts program execution from that address. All interrupts, including NMI, are disabled during reset exception handling and after it ends.

#### (3) Interrupt Exception Handling and Trap Instruction Exception Handling

When interrupt or trap-instruction exception handling begins, the CPU references the stack pointer (ER7) and pushes the program counter and other control registers onto the stack. Next, the CPU

alters the settings of the interrupt mask bits in the control registers. Then the CPU fetches a start address (vector) from the exception vector table and program execution starts from that start address.

Figure 2.16 shows the stack after exception handling ends.



**Figure 2.16 Stack Structure after Exception Handling (Examples)**

#### 2.8.4 Program Execution State

In this state the CPU executes program instructions in sequence.

## 2.8.5 Power-Down State

The power-down state includes both modes in which the CPU stops operating and modes in which the CPU does not stop. There are five modes in which the CPU stops operating: sleep mode, standby mode, subsleep mode, and watch mode. There are also three other power-down modes: medium-speed mode, module stop mode, and subactive mode. In medium-speed mode, the CPU operates on a medium-speed clock. Module stop mode permits halting of the operation of individual modules, other than the CPU. Subactive mode, subsleep mode, and watch mode are power-down modes that use subclock input. For details, see section 4, Power-Down State.

### (1) Sleep Mode

A transition to sleep mode is made if the SLEEP instruction is executed while the software standby bit (SSBY) in the standby control register (SBYCR) and the LSON bit in the low-power control register (LPWRCR) are both cleared to 0. In sleep mode, CPU operations stop immediately after execution of the SLEEP instruction. The contents of CPU registers are retained.

### (2) Standby Mode

A transition to standby mode is made if the SLEEP instruction is executed while the SSBY bit in SBYCR is set to 1 and the LSON bit in LPWRCR and the TMA3 bit in the TMA (timer A) are both cleared to 0. In standby mode, the CPU and clock halt and all MCU operations stop. As long as a specified voltage is supplied, the contents of CPU registers and on-chip RAM are retained.

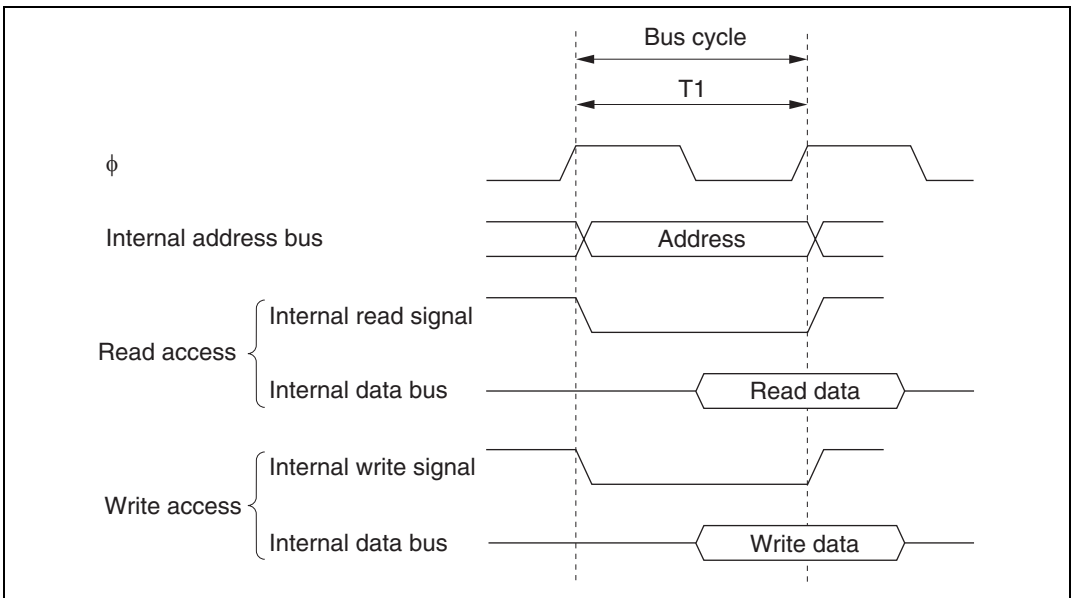
## 2.9 Basic Timing

### 2.9.1 Overview

The CPU is driven by a system clock, denoted by the symbol  $\phi$ . The period from one rising edge of  $\phi$  to the next is referred to as a “state.” The memory cycle or bus cycle consists of one or two states. Different methods are used to access on-chip memory and on-chip supporting modules.

### 2.9.2 On-Chip Memory (ROM, RAM)

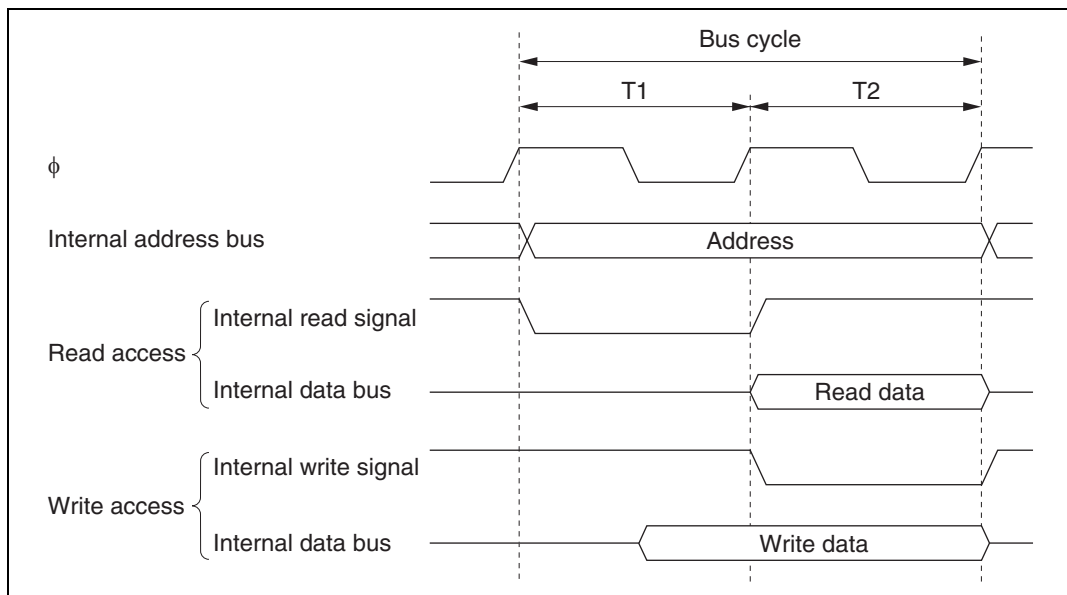
On-chip memory is accessed in one state. The data bus is 16 bits wide, permitting both byte and word transfer instruction. Figure 2.17 shows the on-chip memory access cycle.



**Figure 2.17 On-Chip Memory Access Cycle**

### 2.9.3 On-Chip Supporting Module Access Timing

The on-chip supporting modules are accessed in two states. The data bus is either 8 bits or 16 bits wide, depending on the particular internal I/O register being accessed. Figure 2.18 shows the access timing for the on-chip supporting modules.



**Figure 2.18 On-Chip Supporting Module Access Cycle**

### 2.10 Usage Note

Only register ER0, ER1, ER4, or ER5 should be used when using the TAS instruction. The TAS instruction is not generated by the Renesas Technology H8S or H8/300 series C/C++ compilers. If the TAS instruction is used as a user-defined intrinsic function, ensure that only register ER0, ER1, ER4, or ER5 is used.





## Section 3 MCU Operating Modes

### 3.1 Overview

#### 3.1.1 Operating Mode Selection

This LSI has one operating mode (mode 1). This mode is selected depending on settings of the mode pin (MD0).

Table 3.1 lists the MCU operating modes.

**Table 3.1 MCU Operating Mode Selection**

MCU Operating Mode	MD0	CPU Operating Mode	Description
0	0	—	—
1	1	Advanced	Single-chip mode

The CPU's architecture allows for 4 Gbytes of address space, but this LSI actually accesses a maximum of 16 Mbytes.

Mode 1 operation starts in single-chip mode after reset release.

This LSI can only be used in mode 1. This means that the mode pins must be set at mode 1. Do not changes the inputs at the mode pins during operation.

#### 3.1.2 Register Configuration

This LSI has a mode control register (MDCR) that indicates the inputs at the mode pin (MD0) and a system control register (SYSCR) and that controls the operation of this LSI. Table 3.2 summarizes these registers.

**Table 3.2 MCU Registers**

Name	Abbreviation	R/W	Initial Value	Address*
Mode control register	MDCR	R/W	Undetermined	H'FFE9
System control register	SYSCR	R/W	H'09	H'FFE8

Note: \* Lower 16 bits of the address.

## 3.2 Register Descriptions

### 3.2.1 Mode Control Register (MDCR)

Bit :	7	6	5	4	3	2	1	0
	—	—	—	—	—	—	—	MDS0
Initial value :	0	0	0	0	0	0	0	—*
R/W :	—	—	—	—	—	—	—	R

Note: \* Determined by MD0 pin

MDCR is an 8-bit read-only register monitors the current operating mode of this LSI.

**Bits 7 to 1—Reserved:** These bits cannot be modified and are always set at 0.

**Bit 0—Mode Select 0 (MDS0):** This bit indicates the value which reflects the input levels at mode pin (MD0) (the current operating mode). Bit MDS0 corresponds to MD0 pin. It is read-only bit and cannot be written to. The mode pin (MD0) input levels are latched into these bits when MDCR is read.

### 3.2.2 System Control Register (SYSCR)

Bit :	7	6	5	4	3	2	1	0
	—	—	INTM1	INTM0	XRST	NMIEG1	NMIEG0	—
Initial value :	0	0	0	0	1	0	0	1
R/W :	—	—	R	R/W	R	R/W	R/W	—

**Bits 7 and 6—Reserved.**

**Bits 5 and 4—Interrupt Control Modes 1 and 0 (INTM1, INTM0):** These bits are for selecting the interrupt control mode of the interrupt controller. For details of the interrupt control modes, see section 6.4, Interrupt Operation.

Bit 5	Bit 4	Interrupt Control Mode	Description
INTM1	INTM0	Mode	Description
0	0	0	Interrupt is controlled by bit I (Initial value)
	1	1	Interrupt is controlled by bits I and UI, and ICR
1	0	2	Cannot be used in this LSI
	1	3	Cannot be used in this LSI

**Bit 3—External Reset (XRST) :** Indicates the reset source. When the watchdog timer is used, a reset can be generated by watchdog timer overflow as well as by external reset input. XRST is a read-only bit. It is set to 1 by an external reset and cleared to 0 by watchdog timer overflow.

**Bit 3**

<b>XRST</b>	<b>Description</b>
0	A reset is generated by watchdog timer overflow
1	A reset is generated by an external reset (Initial value)

**Bits 2 and 1—NMI Edge Select 1 and 0 (NMIG1, 0) :** Select the input edge for NMI interrupt.

<b>Bit 2</b>	<b>Bit 1</b>	<b>Description</b>
<b>NIMIEG1</b>	<b>NIMIEG0</b>	
0	0	An interrupt request occurs at falling edge of NMI input (Initial value)
	1	An interrupt request occurs at rising edge of NMI input
1	*	An interrupt request occurs at rising or falling edge of NMI input

Legend: \* Don't care

**Bit 0—Reserved.**

## 3.3 Operating Mode Descriptions

### 3.3.1 Mode 1

The CPU can access a 16 Mbyte address space in advanced mode.

### 3.4 Address Map

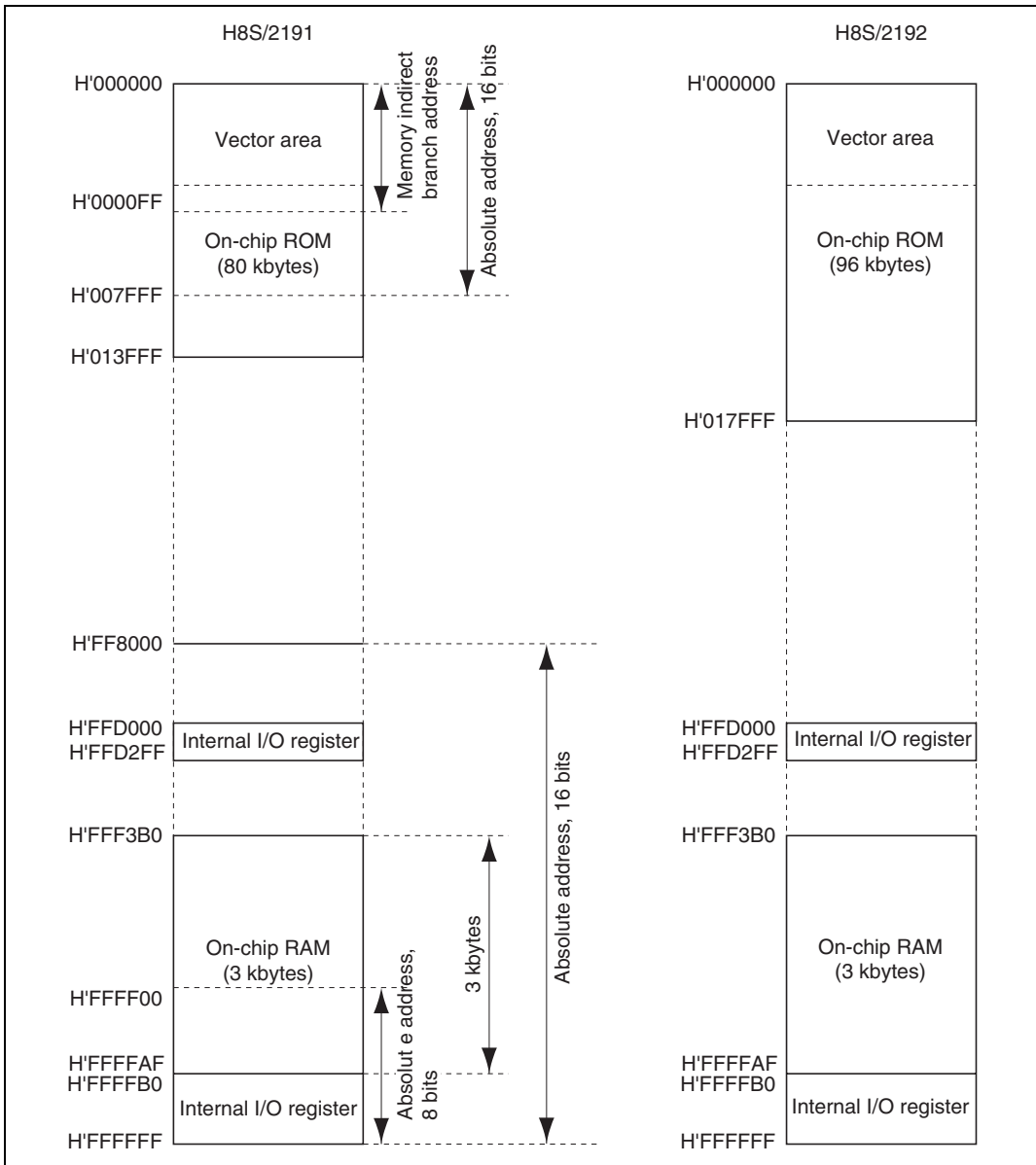


Figure 3.1 Address Map (1)

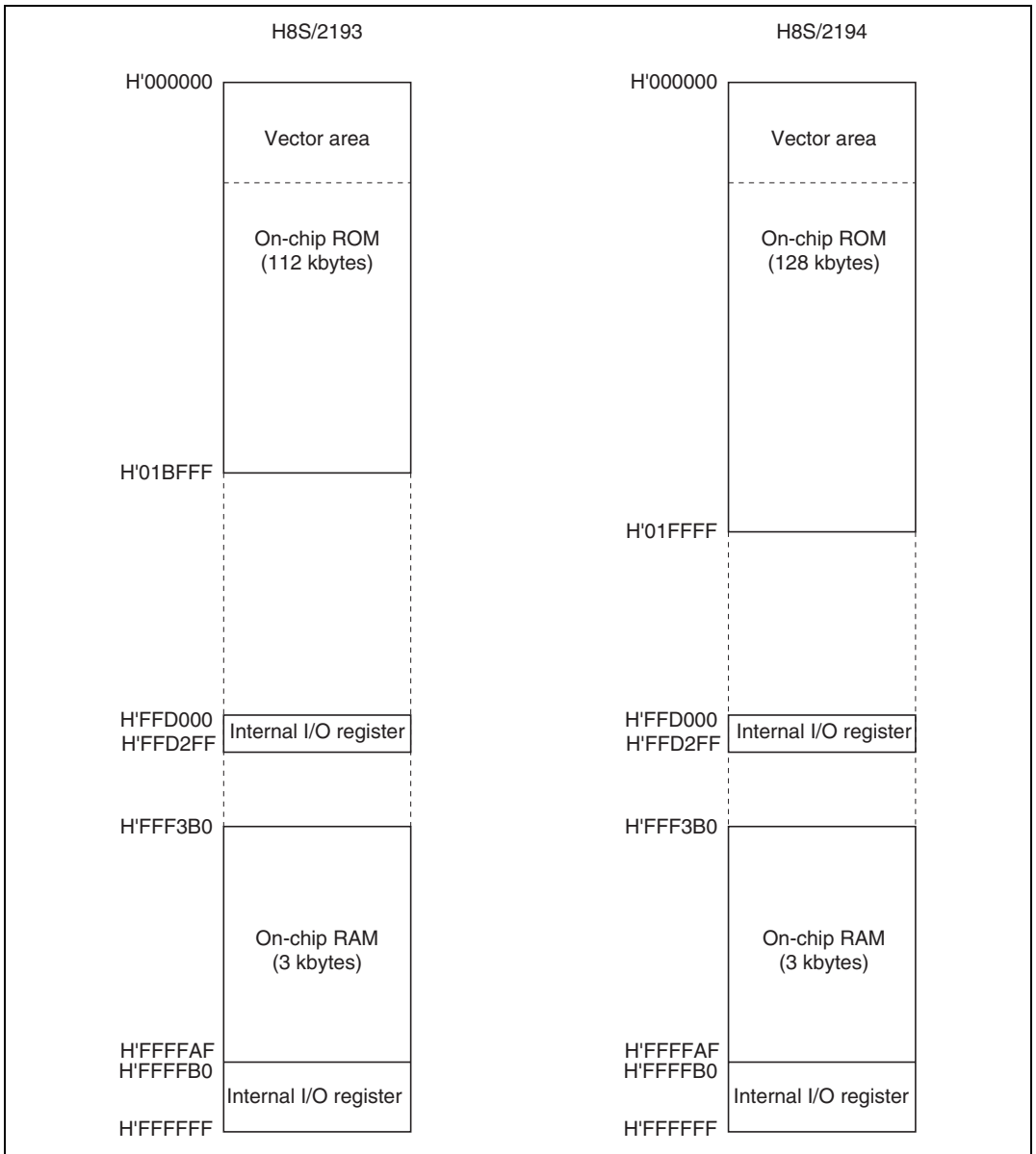


Figure 3.2 Address Map (2)

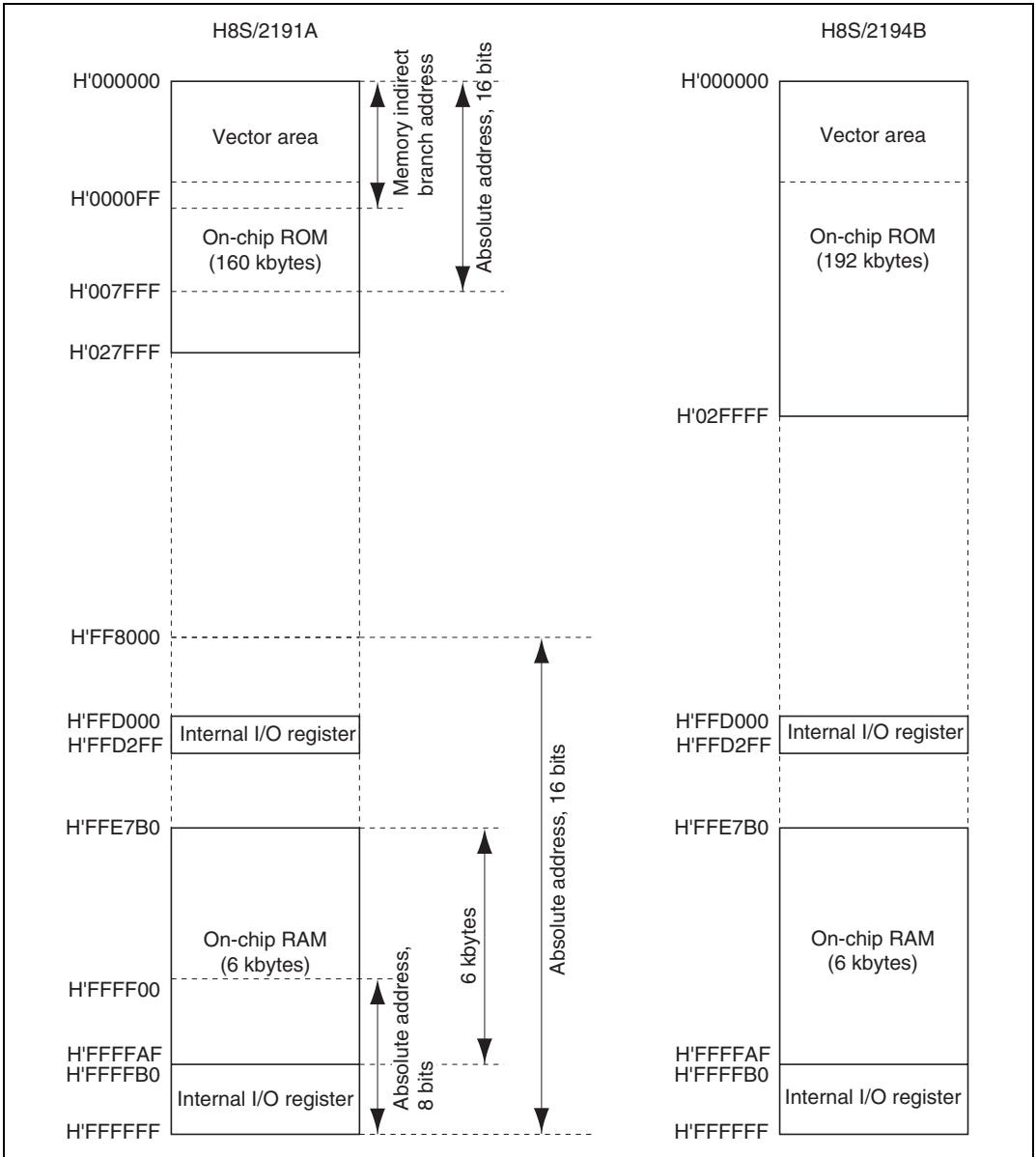
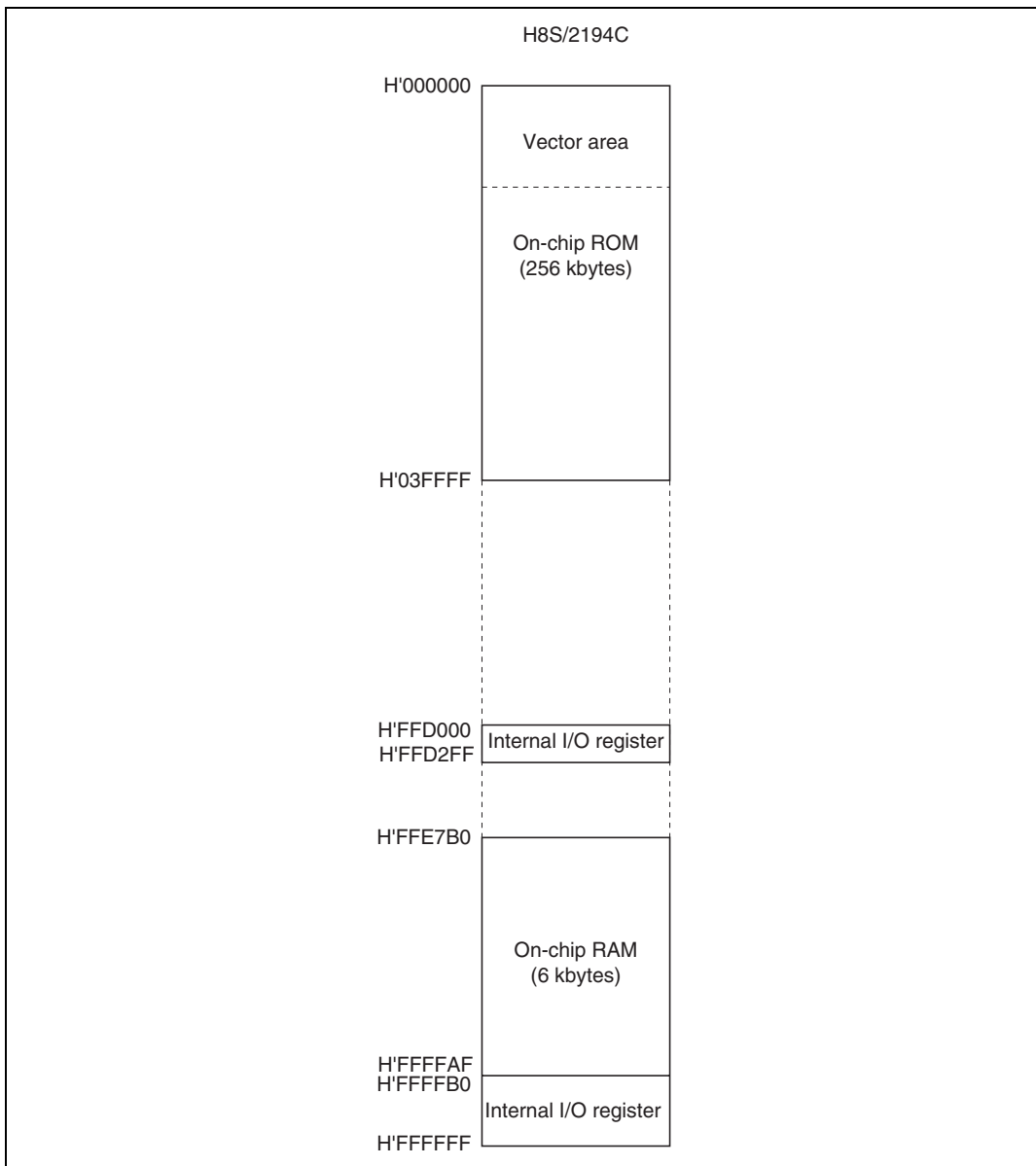


Figure 3.3 Address Map (3)

**Figure 3.4 Address Map (4)**





---

## Section 4 Power-Down State

### 4.1 Overview

In addition to the normal program execution state, this LSI has a power-down state in which operation of the CPU and oscillator is halted and power dissipation is reduced. Low-power operation can be achieved by individually controlling the CPU, on-chip supporting modules, and so on.

This LSI operating modes are as follows:

1. High-speed mode
2. Medium-speed mode
3. Subactive mode
4. Sleep mode
5. Subsleep mode
6. Watch mode
7. Module stop mode
8. Standby mode

Of these, 2 to 8 are power-down modes. Certain combinations of these modes can be set.

After a reset, the MCU is in high-speed mode.

Table 4.1 shows the internal chip states in each mode, and table 4.2 shows the conditions for transition to the various modes. Figure 4.1 shows a mode transition diagram.

**Table 4.1 Internal Chip States in Each Mode**

Function	High-Speed	Medium-Speed	Sleep	Module Stop	Watch	Subactive	Subsleep	Standby	
System clock	Functioning	Functioning	Functioning	Functioning	Halted	Halted	Halted	Halted	
Subclock pulse generator	Functioning	Functioning	Functioning	Functioning	Functioning	Functioning	Functioning	Functioning	
CPU operation	Instructions	Functioning	Medium-speed	Halted	Functioning	Halted	Subclock operation	Halted	Halted
	Registers			Retained		Retained		Retained	Retained
External interrupts	NIMI	Functioning	Functioning	Functioning	Functioning	Functioning	Functioning	Functioning	Functioning
	IRQ0								
	IRQ1								
	IRQ2					Halted	Halted	Functioning	Halted
	IRQ3								
	IRQ4								
	IRQ5								
On-chip supporting module operation	Timer A	Functioning	Functioning	Functioning	Functioning/halted (retained)	Subclock operation	Subclock operation	Subclock operation	Halted (retained)
	Timer B	Functioning	Functioning	Functioning	Functioning/halted (retained)	Halted (retained)	Halted (retained)	Halted (retained)	Halted (retained)
	Timer J								
	Timer L								
	Timer R								
	Timer X1				Functioning/halted (reset)	Halted (reset)	Halted (reset)	Halted (reset)	Halted (reset)
	Watchdog timer	Functioning	Functioning	Functioning	Functioning	Halted (retained)	Halted (retained)	Halted (retained)	Halted (retained)
	PSU	Functioning	Functioning	Functioning	Functioning	Subclock operation	Subclock operation	Subclock operation	Halted
	IIC				Functioning/halted (reset)	Halted (reset)	Halted (reset)	Halted (reset)	Halted (reset)
	SCI1								
SCI2				Functioning/halted (retained)	Halted (retained)	Halted (retained)	Halted (retained)	Halted (retained)	
14-bit PWM									
8-bit PWM									
A/D				Functioning/halted (reset)	Halted (reset)	Halted (reset)	Halted (reset)	Halted (reset)	
I/O	Functioning	Functioning	Retained	Functioning	Halted	Functioning	Retained	Halted	
12-bit PWM	Functioning	Functioning	Halted (reset)	Functioning/halted (reset)	Halted (reset)	Halted (reset)	Halted (reset)	Halted (reset)	
Servo									

- Notes:
1. "Halted (retained)" means that internal register values are retained. The internal state is "operation suspended."
  2. "Halted (reset)" means that internal register values and internal states are initialized.
  3. In module stop mode, only modules for which a stop setting has been made are halted (reset or retained).
  4. In the power-down mode, the analog section of the servo circuits are not turned off, therefore Vcc (Servo) current does not go low. When power-down is needed, externally shut down the analog system power.

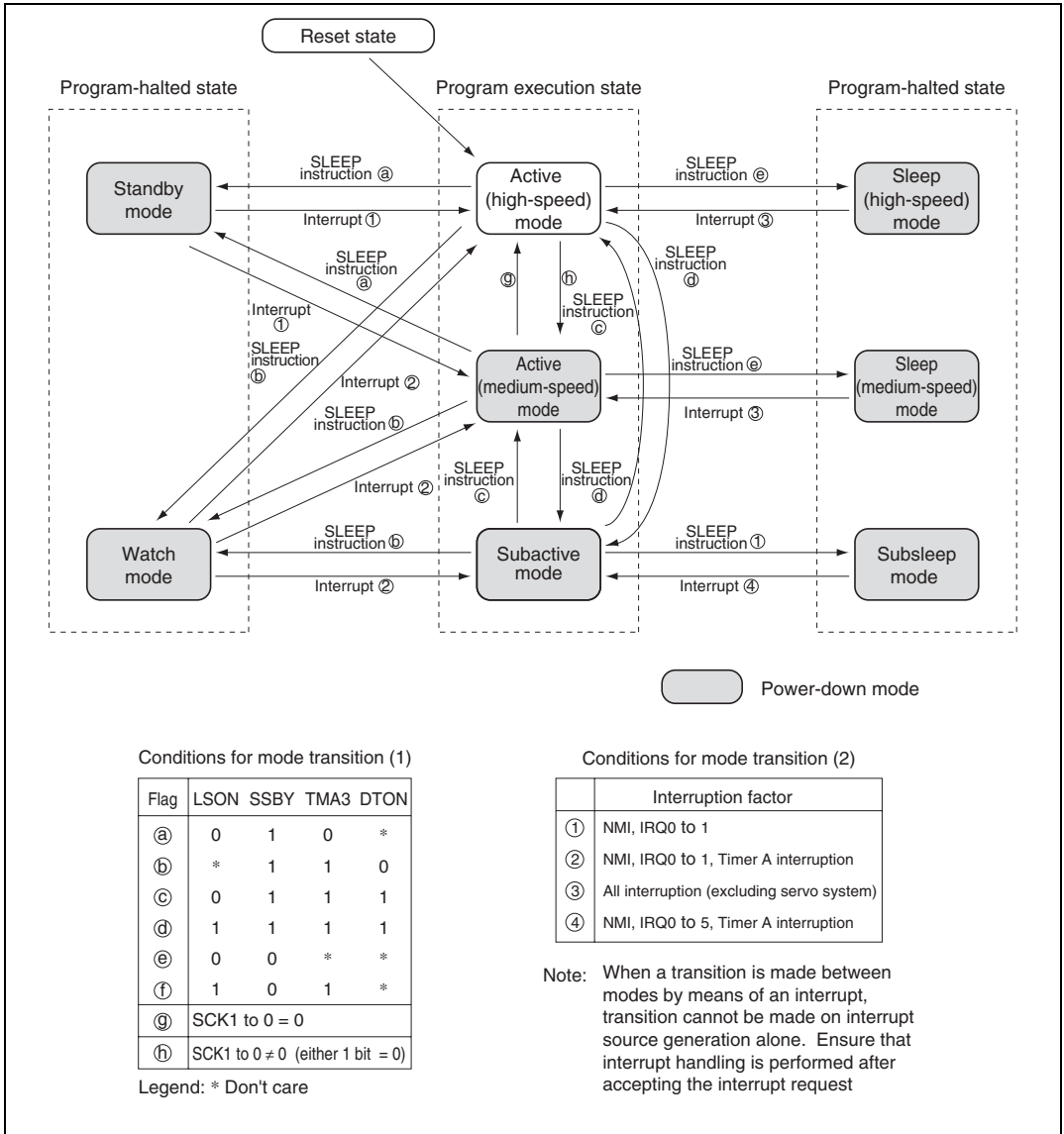


Figure 4.1 Mode Transitions

Table 4.2 Power-Down Mode Transition Conditions

State before Transition	Control Bit States at Time of Transition				State after Transition by SLEEP Instruction	State after Return by Interrupt
	SSBY	TMA3	LSON	DTON		
High-speed/ medium-speed	0	*	0	*	Sleep	High-speed/ medium-speed* <sup>1</sup>
	0	*	1	*	—	—
	1	0	0	*	Standby	High-speed/ medium-speed* <sup>1</sup>
	1	0	1	*	—	—
	1	1	0	0	Watch	High-speed/ medium-speed* <sup>1</sup>
	1	1	1	0	Watch	Subactive
	1	1	0	1	—	—
	1	1	1	1	Subactive	—
Subactive	0	0	*	*	—	—
	0	1	0	*	—	—
	0	1	1	*	Subsleep	Subactive
	1	0	*	*	—	—
	1	1	0	0	Watch	High-speed/ medium-speed* <sup>2</sup>
	1	1	1	0	Watch	Subactive
	1	1	0	1	High-speed/ medium-speed* <sup>2</sup>	—
	1	1	1	1	—	—

Legend: \* Don't care

—: Do not set.

Notes: 1. Returns to the state before transition.

2. Mode varies depending on the state of SCK1 to SCK0.

### 4.1.1 Register Configuration

The power-down state is controlled by the SBYCR, LPWRCR, TMA (Timer A), and MSTPCR registers. Table 4.3 summarizes these registers.

**Table 4.3 Power-Down State Registers**

<b>Name</b>	<b>Abbreviation</b>	<b>R/W</b>	<b>Initial Value</b>	<b>Address*</b>
Standby control register	SBYCR	R/W	H'00	H'FFEA
Low-power control register	LPWRCR	R/W	H'00	H'FFEB
Module stop control register	MSTPCRH	R/W	H'FF	H'FFEC
	MSTPCRL	R/W	H'FF	H'FFED
Timer mode register	TMA	R/W	H'30	H'FFBA

Note: \* Lower 16 bits of the address.

## 4.2 Register Descriptions

### 4.2.1 Standby Control Register (SBYCR)

Bit :	7	6	5	4	3	2	1	0
	SSBY	STS2	STS1	STS0	—	—	SCK1	SCK0
Initial value :	0	0	0	0	0	0	0	0
R/W :	R/W	R/W	R/W	R/W	—	—	R/W	R/W

SBYCR is an 8-bit readable/writable register that performs power-down mode control. SBYCR is initialized to H'00 by a reset.

**Bit 7—Software Standby (SSBY):** Determines the operating mode, in combination with other control bits, when a power-down mode transition is made by executing a SLEEP instruction. The SSBY setting is not changed by a mode transition due to an interrupt, etc.

#### Bit 7

SSBY	Description
0	Transition to sleep mode after execution of SLEEP instruction in high-speed mode or medium-speed mode  Transition to subsleep mode after execution of SLEEP instruction in subactive mode (Initial value)
1	Transition to standby mode, subactive mode, or watch mode after execution of SLEEP instruction in high-speed mode or medium-speed mode  Transition to watch mode or high-speed mode after execution of SLEEP instruction in subactive mode

**Bits 6 to 4—Standby Timer Select 2 to 0 (STS2 to STS0):** These bits select the time the MCU waits for the clock to stabilize when standby mode, watch mode, or subactive mode is cleared and a transition is made to high-speed mode or medium-speed mode by means of a specific interrupt or instruction. With crystal oscillation, see table 4.5 and make a selection according to the operating frequency so that the standby time is at least 10 ms (the oscillation settling time). With an external clock, any selection can be made.

(With FLASH ROM version, do not set the standby time to 16 states.)

Bit 6	Bit 5	Bit 4	Description
STS2	STS1	STS0	
0	0	0	Standby time = 8192 states
0	0	1	Standby time = 16384 states
0	1	0	Standby time = 32768 states
0	1	1	Standby time = 65536 states
1	0	0	Standby time = 131072 states
1	0	1	Standby time = 262144 states
1	1	*	Standby time = 16 states <sup>*1</sup>

Legend: \* Don't care

Note: 1. With FLASH ROM version, do not set the standby time to 16 states.  
The standby time is 32 states when transitioned to medium-speed mode  $\phi/32$  (SCK1 = 1, SCK0 = 0).

**Bits 3 and 2—Reserved:** These bits cannot be modified and are always read as 0.

**Bits 1 and 0—System Clock Select 1, 0 (SCK1, SCK0):** These bits select the CPU clock for the bus master in high-speed mode and medium-speed mode.

Bit 1	Bit 0	Description
SCK1	SCK0	
0	0	Bus master is in high-speed mode (Initial value)
0	1	Medium-speed clock is $\phi/16$
1	0	Medium-speed clock is $\phi/32$
1	1	Medium-speed clock is $\phi/64$

#### 4.2.2 Low-Power Control Register (LPWRCR)

Bit :	7	6	5	4	3	2	1	0
	DTON	LSON	NESEL	—	—	—	SA1	SA0
Initial value :	0	0	0	0	0	0	0	0
R/W :	R/W	R/W	R/W	—	—	—	R/W	R/W

LPWRCR is an 8-bit readable/writable register that performs power-down mode control. LPWRCR is initialized to H'00 by a reset.

**Bit 7—Direct-Transfer on Flag (DTON):** Specifies whether a direct transition is made between high-speed mode, medium-speed mode, and subactive mode when making a power-down transition by executing a SLEEP instruction. The operating mode to which the transition is made after SLEEP instruction execution is determined by a combination of other control bits.

##### Bit 7

DTON	Description
0	<ul style="list-style-type: none"> <li>When a SLEEP instruction is executed in high-speed mode or medium-speed mode, a transition is made to sleep mode, standby mode, or watch mode</li> <li>When a SLEEP instruction is executed in subactive mode, a transition is made to subsleep mode or watch mode (Initial value)</li> </ul>
1	<ul style="list-style-type: none"> <li>When a SLEEP instruction is executed in high-speed mode or medium-speed mode, transition is made directly to subactive mode, or a transition is made to sleep mode or standby mode</li> <li>When a SLEEP instruction is executed in subactive mode, a transition is made directly to high-speed mode, or a transition is made to subsleep mode</li> </ul>



**Bit 6—Low-Speed on Flag (LSON):** Determines the operating mode in combination with other control bits when making a power-down transition by executing a SLEEP instruction. Also controls whether a transition is made to high-speed mode or to subactive mode when watch mode is cleared.

**Bit 6**

LSON	Description
0	<ul style="list-style-type: none"> <li>When a SLEEP instruction is executed in high-speed mode or medium-speed mode, transition is made to sleep mode, standby mode, or watch mode</li> <li>When a SLEEP instruction is executed in subactive mode, a transition is made to watch mode, or directly to high-speed mode</li> <li>After watch mode is cleared, a transition is made to high-speed mode (Initial value)</li> </ul>
1	<ul style="list-style-type: none"> <li>When a SLEEP instruction is executed in high-speed mode a transition is made to watch mode, subactive mode, sleep mode or standby mode</li> <li>When a SLEEP instruction is executed in subactive mode, a transition is made to subsleep mode or watch mode</li> <li>After watch mode is cleared, a transition is made to subactive mode</li> </ul>

**Bit 5—Noise Elimination Sampling Frequency Select (NESEL):** Selects the frequency at which the subclock ( $\phi_w$ ) generated by the subclock pulse generator is sampled with the clock ( $\phi$ ) generated by the system clock oscillator. When  $\phi = 5$  MHz or higher, clear this bit to 0.

**Bit 5**

NESEL	Description
0	Sampling at $\phi$ divided by 16
1	Sampling at $\phi$ divided by 4

**Bits 4 to 2—Reserved:** These bits cannot be modified and are always read as 0.

**Bits 1 and 0—Subactive Mode Clock Select 1, 0 (SA1, SA0):** These bits select the CPU operating clock in the subactive mode. These bits cannot be modified in the subactive mode.

Bit 1	Bit 0	Description
SA1	SA0	
0	0	Operating clock of CPU is $\phi w/8$ (Initial value)
0	1	Operating clock of CPU is $\phi w/4$
1	*	Operating clock of CPU is $\phi w/2$

Legend: \* Don't care

### 4.2.3 Timer Register A (TMA)

Bit :	7	6	5	4	3	2	1	0
	TMAOV	TMAIE	—	—	TMA3	TMA2	TMA1	TMA0
Initial value :	0	0	1	1	0	0	0	0
R/W :	R/(W)*	R/W	R/W	R/W	R/W	R/W	R/W	R/W

Note: \* Only 0 can be written, to clear the flag.

The timer register A (TMA) controls timer A interrupts and selects input clock.

Only Bit 3 is explained here. For details of other bits, see section 12.2.1, Timer Mode Register A (TMA).

TMA is a readable/writable register which is initialized to H'30 by a reset.

**Bit 3—Clock Source, Prescaler Select (TMA3):** Selects Timer A clock source between PSS and PSW.

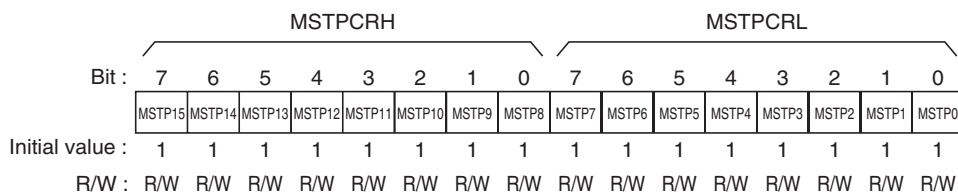
Also controls transition operation to the power-down mode. The operation mode to which the MCU is transitioned after SLEEP instruction execution is determined by the combination with other control bits than this bit.

For details, see the description of Clock Select 2 to 0 in section 12.2.1, Timer Mode Register A (TMA).

### Bit 3

TMA3	Description
0	<ul style="list-style-type: none"> <li>Timer A counts <math>\phi</math>-based prescaler (PSS) divided clock pulses</li> <li>When a SLEEP instruction is executed in high-speed mode or medium-speed mode, a transition is made to sleep mode or software standby mode (Initial value)</li> </ul>
1	<ul style="list-style-type: none"> <li>Timer A counts <math>\phi_w</math>-based prescaler (PSW) divided clock pulses</li> <li>When a SLEEP instruction is executed in high-speed mode or medium-speed mode, a transition is made to sleep mode, watch mode, or subactive mode</li> <li>When a SLEEP instruction is executed in subactive mode, a transition is made to subsleep mode, watch mode, or high-speed mode</li> </ul>

## 4.2.4 Module Stop Control Register (MSTPCR)



MSTPCR comprises two 8-bit readable/writable registers that perform module stop mode control. MSTPCR is initialized to H'FFFF by a reset.

**MSTPCRH and MSTPCRL Bits 7 to 0—Module Stop (MSTP 15 to MSTP 0):** These bits specify module stop mode. See table 4.4 for the method of selecting on-chip supporting modules.

### MSTPCRH, MSTPCRL Bits 7 to 0

MSTP 15 to MSTP 0	Description
0	Module stop mode is cleared
1	Module stop mode is set (Initial value)

### 4.3 Medium-Speed Mode

When the SCK1 and SCK0 bits in SBYCR are set to 1 in high-speed mode, the operating mode changes to medium-speed mode at the end of the bus cycle. In medium-speed mode, the CPU operates on the operating clock ( $\phi_{16}$ ,  $\phi_{32}$  or  $\phi_{64}$ ) specified by the SCK1 and SCK0 bits. The on-chip supporting modules other than the CPU always operate on the high-speed clock ( $\phi$ ).

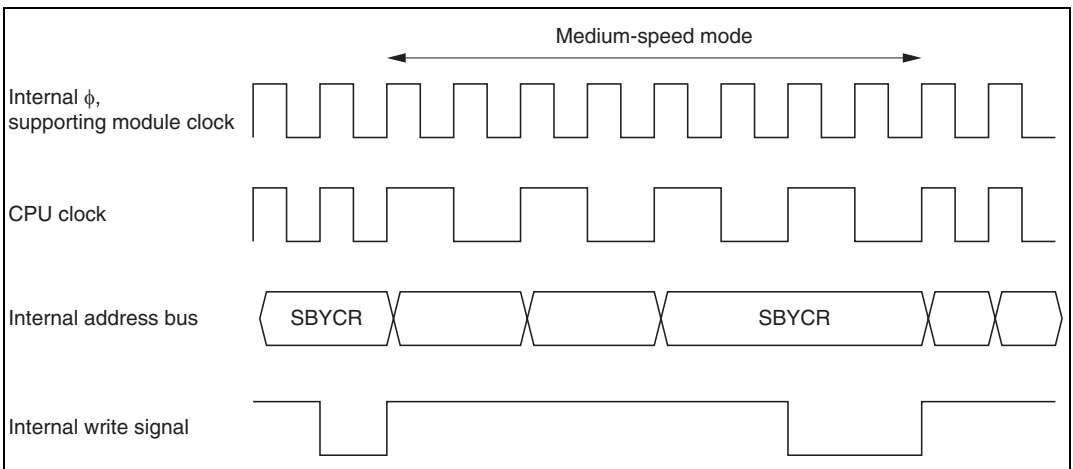
In medium-speed mode, a bus access is executed in the specified number of states with respect to the bus master operating clock. For example, if  $\phi_{16}$  is selected as the operating clock, on-chip memory is accessed in 16 states, and internal I/O registers in 32 states.

Medium-speed mode is cleared by clearing the both bits SCK1 and SCK0 to 0. A transition is made to high-speed mode and medium-speed mode is cleared at the end of the current bus cycle. If a SLEEP instruction is executed when the SSBY bit in SBYCR and the LSON bit in LPWRCR are cleared to 0, a transition is made to sleep mode. When sleep mode is cleared by an interrupt, medium-speed mode is restored.

If a SLEEP instruction is executed when the SSBY bit in SBYCR is set to 1, and the LSON bit in LPWRCR and the TMA3 bit in TMA (Timer A) are both cleared to 0, a transition is made to software standby mode. When standby mode is cleared by an external interrupt, medium-speed mode is restored.

When the  $\overline{\text{RES}}$  pin is driven low, a transition is made to the reset state, and medium-speed mode is cleared. The same applies in the case of a reset caused by overflow of the watchdog timer.

Figure 4.2 shows the timing for transition to and clearance of medium-speed mode.



**Figure 4.2 Medium-Speed Mode Transition and Clearance Timing**

## 4.4 Sleep Mode

### 4.4.1 Sleep Mode

If a SLEEP instruction is executed when the SSBY bit in SBYCR and the LSON bit in LPWRCR are both cleared to 0, the CPU enters sleep mode. In sleep mode, CPU operation stops but the contents of the CPU's internal registers are retained. Other supporting modules (excluding the servo circuit and 12-bit PWM) do not stop.

### 4.4.2 Clearing Sleep Mode

Sleep mode is cleared by any interrupt, or with the  $\overline{\text{RES}}$  pin.

#### (1) Clearing with an Interrupt

When an interrupt request signal is input, sleep mode is cleared and interrupt exception handling is started. Sleep mode will not be cleared if interrupts are disabled, or if interrupts other than NMI have been masked by the CPU.

#### (2) Clearing with the $\overline{\text{RES}}$ Pin

When the  $\overline{\text{RES}}$  pin is driven low, the reset state is entered. When the  $\overline{\text{RES}}$  pin is driven high after the prescribed reset input period, the CPU begins reset exception handling.

## 4.5 Module Stop Mode

### 4.5.1 Module Stop Mode

Module stop mode can be set for individual on-chip supporting modules.

When the corresponding MSTP bit in MSTPCR is set to 1, module operation stops at the end of the bus cycle and a transition is made to module stop mode. The CPU continues operating independently.

Table 4.4 shows MSTP bits and the on-chip supporting modules.

When the corresponding MSTP bit is cleared to 0, module stop mode is cleared and the module starts operating again at the end of the bus cycle. In module stop mode, the internal states of modules other than the SCI1, A/D converter, Timer X1, and Servo circuit, are retained.

After reset release, all modules are in module stop mode.

When an on-chip supporting module is in module stop mode, read/write access to its registers is disabled.

**Table 4.4 MSTP Bits and Corresponding On-Chip Supporting Modules**

Register	Bit	Module
MSTPCRH	MSTP15	Timer A
	MSTP14	Timer B
	MSTP13	Timer J
	MSTP12	Timer L
	MSTP11	Timer R
	MSTP10	Timer X1
	MSTP9	—
	MSTP8	Serial communication interface 1 (SCI1)
MSTPCRL	MSTP7	Serial communication interface 2 (SCI2)
	MSTP6	I <sup>2</sup> C bus interface (IIC)
	MSTP5	14-bit PWM
	MSTP4	8-bit PWM
	MSTP3	—
	MSTP2	A/D converter
	MSTP1	Servo circuit, 12-bit PWM
	MSTP0	—

## 4.6 Standby Mode

### 4.6.1 Standby Mode

If a SLEEP instruction is executed when the SSBY bit in SBYCR is set to 1, the LSON bit in LPWRCR is cleared to 0, and the TMA3 bit in TMA (Timer A) is cleared to 0, standby mode is entered. In this mode, the CPU, on-chip supporting modules, and oscillator (except for subclock oscillator) all stop. However, contents of the CPU's internal registers and data in the built-in RAM as well as functions of the SCI1, timer X1 and built-in peripheral circuits (except the servo circuit) are maintained in the current state. The I/O port, at this time, is caused to the high impedance state. In this mode the oscillator stops, and therefore power dissipation is significantly reduced.

### 4.6.2 Clearing Standby Mode

Standby mode is cleared by an external interrupt (NMI pin, or pin  $\overline{\text{IRQ0}}$  and  $\overline{\text{IRQ1}}$ , or by means of the  $\overline{\text{RES}}$  pin.

#### (1) Clearing with an Interrupt

When an NMI,  $\overline{\text{IRQ0}}$  and  $\overline{\text{IRQ1}}$  interrupt request signal is input, clock oscillation starts, and after the elapse of the time set in bits STS2 to STS0 in SBYCR, stable clocks are supplied to the entire chip, standby mode is cleared, and interrupt exception handling is started.

Standby mode cannot be cleared with an  $\overline{\text{IRQ0}}$  and  $\overline{\text{IRQ1}}$  interrupt if the corresponding enable bit has been cleared to 0 or has been masked by the CPU.

#### (2) Clearing with the $\overline{\text{RES}}$ Pin

When the  $\overline{\text{RES}}$  pin is driven low, clock oscillation is started. At the same time as clock oscillation starts, clocks are supplied to the entire chip. Note that the  $\overline{\text{RES}}$  pin must be held low until clock oscillation stabilizes. When the  $\overline{\text{RES}}$  pin goes high, the CPU begins reset exception handling.

### 4.6.3 Setting Oscillation Settling Time after Clearing Standby Mode

Bits STS2 to STS0 in SBYCR should be set as described below.

#### (1) Using a Crystal Oscillator

Set bits STS2 to STS0 so that the standby time is at least 10 ms (the oscillation settling time).

Table 4.5 shows the standby times for different operating frequencies and settings of bits STS2 to STS0.

**Table 4.5 Oscillation Settling Time Settings**

STS2	STS1	STS0	Standby Time	10 MHz	8 MHz	Unit
0	0	0	8192 states	0.8	1.0	ms
		1	16384 states	1.6	2.0	
	1	0	32768 states	3.3	4.1	
		1	65536 states	6.6	8.2	
1	0	0	131072 states	13.1	16.4	
		1	262144 states	26.2	32.8	
	1	*	16 states* <sup>1</sup>	1.6	2.0	μs

: Recommended time setting

Legend: \* Don't care

Note: 1. With Flash memory version, do not set the standby time to 16 states. The standby time is 32 states when transited to medium-speed mode  $\phi/32$  (SCK1 = 1, SCK0 = 0).

## (2) Using an External Clock

Any value can be set.



## 4.7 Watch Mode

### 4.7.1 Watch Mode

If a SLEEP instruction is executed in high-speed mode, medium-speed mode or subactive mode when the SSBY in SBYCR is set to 1, the DTON bit in LPWRCCR is cleared to 0, and the TMA3 bit in TMA (Timer A) is set to 1, the CPU makes a transition to watch mode.

In this mode, the CPU and all on-chip supporting modules except Timer A stop. As long as the prescribed voltage is supplied, the contents of some of the CPU's internal registers and on-chip RAM are retained, and I/O ports are placed in the high-impedance state.

### 4.7.2 Clearing Watch Mode

Watch mode is cleared by an interrupt (Timer A interrupt, NMI pin, or pin  $\overline{\text{IRQ0}}$  and  $\overline{\text{IRQ1}}$ ), or by means of the RES pin.

#### (1) Clearing with an Interrupt

When an interrupt request signal is input, watch mode is cleared and a transition is made to high-speed mode or medium-speed mode if the LSON bit in LPWRCCR is cleared to 0, or to subactive mode if the LSON bit is set to 1. When making a transition to medium-speed mode, after the elapse of the time set in bits STS2 to STS0 in SBYCR, stable clocks are supplied to the entire chip, and interrupt exception handling is started.

Watch mode cannot be cleared with an  $\overline{\text{IRQ0}}$  and  $\overline{\text{IRQ1}}$  interrupt if the corresponding enable bit has been cleared to 0, or with an on-chip supporting module interrupt if acceptance of the relevant interrupt has been disabled by the interrupt enable register or masked by the CPU.

See section 4.6.3, Setting Oscillation Settling Time after Clearing Standby Mode, for the oscillation settling time setting when making a transition from watch mode to high-speed mode.

#### (2) Clearing with the RES Pin

See (2) Clearing with the RES Pin in section 4.6.2, Clearing Standby Mode.

## 4.8 Subsleep Mode

### 4.8.1 Subsleep Mode

If a SLEEP instruction is executed in subactive mode when the SSBY in SBYCR is cleared to 0, the LSON bit in LPWRCR is set to 1, and the TMA3 bit in TMA (Timer A) is set to 1, the CPU makes a transition to subsleep mode.

In this mode, the CPU and all on-chip supporting modules other than Timer A stop. As long as the prescribed voltage is supplied, the contents of the CPU, some of its on-chip registers and on-chip RAM are retained, and I/O ports retain their states prior to the transition.

### 4.8.2 Clearing Subsleep Mode

Subsleep mode is cleared by an interrupt (Timer A interrupt, NMI pin, or pin  $\overline{\text{IRQ0}}$  to  $\overline{\text{IRQ5}}$ ), or by means of the  $\overline{\text{RES}}$  pin.

#### (1) Clearing with an Interrupt

When an interrupt request signal is input, subsleep mode is cleared and interrupt exception handling is started. Subsleep mode cannot be cleared with an  $\overline{\text{IRQ0}}$  to  $\overline{\text{IRQ5}}$  interrupt if the corresponding enable bit has been cleared to 0, or with an on-chip supporting module interrupt if acceptance of the relevant interrupt has been disabled by the interrupt enable register or masked by the CPU.

#### (2) Clearing with the $\overline{\text{RES}}$ Pin

See (2) Clearing with the  $\overline{\text{RES}}$  Pin in section 4.6.2, Clearing Standby Mode.

## 4.9 Subactive Mode

### 4.9.1 Subactive Mode

If a SLEEP instruction is executed in high-speed mode when the SSBY bit in SBYCR, the DTON bit in LPWRCCR, and the TMA3 bit in TMA (Timer A) are all set to 1, the CPU makes a transition to subactive mode. When an interrupt is generated in watch mode, if the LSON bit in LPWRCCR is set to 1, a transition is made to subactive mode. When an interrupt is generated in subsleep mode, a transition is made to subactive mode.

In subactive mode, the CPU performs sequential program execution at low speed on the subclock. In this mode, all on-chip supporting modules other than Timer A stop.

### 4.9.2 Clearing Subactive Mode

Subsleep mode is cleared by a SLEEP instruction, or by means of the  $\overline{\text{RES}}$  pin.

#### (1) Clearing with a SLEEP Instruction

When a SLEEP instruction is executed while the SSBY bit in SBYCR is set to 1, the DTON bit in LPWRCCR is cleared to 0, and the TMA3 bit in TMA (Timer A) is set to 1, subactive mode is cleared and a transition is made to watch mode. When a SLEEP instruction is executed while the SSBY bit in SBYCR is cleared to 0, the LSON bit in LPWRCCR is set to 1, and the TMA3 bit in TMA (Timer A) is set to 1, a transition is made to subsleep mode. When a SLEEP instruction is executed while the SSBY bit in SBYCR is set to 1, the DTON bit is set to 1 and the LSON bit is cleared to 0 in LPWRCCR, and the PSS bit in TCSR (WDT1) is set to 1, a transition is made directly to high-speed or medium-speed mode.

For details of direct transition, see section 4.10, Direct Transition.

#### (2) Clearing with the $\overline{\text{RES}}$ Pin

See (2) Clearing with the  $\overline{\text{RES}}$  Pin in section 4.6.2, Clearing Standby Mode.

## 4.10 Direct Transition

### 4.10.1 Overview of Direct Transition

There are three operating modes in which the CPU executes programs: high-speed mode, medium-speed mode, and subactive mode. A transition between high-speed mode and subactive mode without halting the program\* is called a direct transition. A direct transition can be carried out by setting the DTON bit in LPWRCCR to 1 and executing a SLEEP instruction. After the transition, direct transition interrupt exception handling is started.

#### (1) Direct Transition from High-Speed Mode to Subactive Mode

If a SLEEP instruction is executed in high-speed mode while the SSBY bit in SBYCR, the LSON bit and DTON bit in LPWRCCR, and the TMA3 bit in TMA (Timer A) are all set to 1, a transition is made to subactive mode.

#### (2) Direct Transition from Subactive Mode to High-Speed Mode/Medium-Speed Mode

If a SLEEP instruction is executed in subactive mode while the SSBY bit in SBYCR is set to 1, the LSON bit is cleared to 0 and the DTON bit is set to 1 in LPWRCCR, and the TMA3 bit in TMA (Timer A) is set to 1, after the elapse of the time set in bits STS2 to STS0 in SBYCR, a transition is made to directly to high-speed mode.

Note: \* At the time of transition from subactive mode to high- or medium-speed mode, an oscillation stabilization wait time is generated.

# Section 5 Exception Handling


## 5.1 Overview

### 5.1.1 Exception Handling Types and Priority

As table 5.1 indicates, exception handling may be caused by a reset, trap instruction, or interrupt. Exception handling is prioritized as shown in table 5.1. If two or more exceptions occur simultaneously, they are accepted and processed in order of priority. Trap instruction exceptions are accepted at all times in the program execution state.

Exception handling sources, the stack structure, and the operation of the CPU vary depending on the interrupt control mode set by the INTM0 and INTM1 bits in SYSCR.

**Table 5.1 Exception Types and Priority**

Priority	Exception Type	Start of Exception Handling
 High	Reset	Starts immediately after a low-to-high transition at the $\overline{\text{RES}}$ pin, or when the watchdog timer overflows
	Trace <sup>*1</sup>	Starts when execution of the current instruction or exception handling ends, if the trace (T) bit is set to 1
	Interrupt	Starts when execution of the current instruction or exception handling ends, if an interrupt request has been issued <sup>*2</sup>
	Direct transition	Started by a direct transition resulting from execution of a SLEEP instruction
	Trap instruction (TRAPA) <sup>*3</sup>	Started by execution of a trap instruction (TRAPA)
Low		

- Notes:
1. Traces are enabled only in interrupt control modes 2 and 3. (They cannot be used in this LSI.) Trace exception handling is not executed after execution of an RTE instruction.
  2. Interrupt detection is not performed on completion of ANDC, ORC, XORC, or LDC instruction execution, or on completion of reset exception handling.
  3. Trap instruction exception handling requests are accepted at all times in the program execution state.

### 5.1.2 Exception Handling Operation

Exceptions originate from various sources. Trap instructions and interrupts are handled as follows:

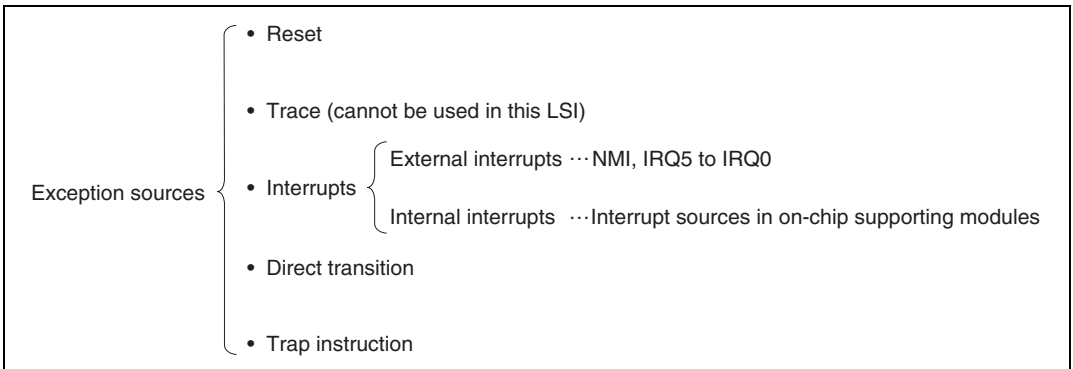
- [1] The program counter (PC) and condition-code register (CCR) are pushed onto the stack.
- [2] The interrupt mask bits are updated. The T bit is cleared to 0.
- [3] A vector address corresponding to the exception source is generated, and program execution starts from that address.

For a reset exception, steps [2] and [3] above are carried out.

### 5.1.3 Exception Sources and Vector Table

The exception sources are classified as shown in figure 5.1. Different vector addresses are assigned to different exception sources.

Table 5.2 lists the exception sources and their vector addresses.



**Figure 5.1 Exception Sources**

**Table 5.2 Exception Vector Table**

<b>Exception Source</b>	<b>Vector Number</b>	<b>Vector Address<sup>*1</sup></b>	
Reset	0	H'0000 to H'0003	
Reserved for system use	1	H'0004 to H'0007	
	2	H'0008 to H'000B	
	3	H'000C to H'000F	
	4	H'0010 to H'0013	
	5	H'0014 to H'0017	
Direct transition	6	H'0018 to H'001B	
External interrupt NMI	7	H'001C to H'001F	
Trap instruction (4 sources)	8	H'0020 to H'0023	
	9	H'0024 to H'0027	
	10	H'0028 to H'002B	
	11	H'002C to H'002F	
Reserved for system use	12	H'0030 to H'0033	
	13	H'0034 to H'0037	
	14	H'0038 to H'003B	
	15	H'003C to H'003F	
Address trap	#0	16	H'0040 to H'0043
	#1	17	H'0044 to H'0047
	#2	18	H'0048 to H'004B
Internal interrupt (IC)	19	H'004C to H'004F	
Internal interrupt (HSW1)	20	H'0050 to H'0053	
External interrupt	IRQ0	21	H'0054 to H'0057
	IRQ1	22	H'0058 to H'005B
	IRQ2	23	H'005C to H'005F
	IRQ3	24	H'0060 to H'0063
	IRQ4	25	H'0064 to H'0067
	IRQ5	26	H'0068 to H'006B
Reserved	27	H'006C to H'006F	
Internal interrupt <sup>*2</sup>	33	H'0084 to H'0087	
	30	H'0088 to H'008B	
	67	H'010C to H'010F	

Notes: 1. Lower 16 bits of the address.

2. For details on internal interrupt vectors, see section 6.3.3, Interrupt Exception Vector Table.

## 5.2 Reset

### 5.2.1 Overview

A reset has the highest exception priority.

When the  $\overline{\text{RES}}$  pin goes low, all processing halts and the MCU enters the reset state. A reset initializes the internal state of the CPU and the registers of on-chip supporting modules.

Immediately after a reset, interrupt control mode 0 is set.

Reset exception handling begins when the  $\overline{\text{RES}}$  pin changes from low to high.

The MCUs can also be reset by overflow of the watchdog timer. For details, see section 18, Watchdog Timer (WDT).

### 5.2.2 Reset Sequence

The MCU enters the reset state when the  $\overline{\text{RES}}$  pin goes low.

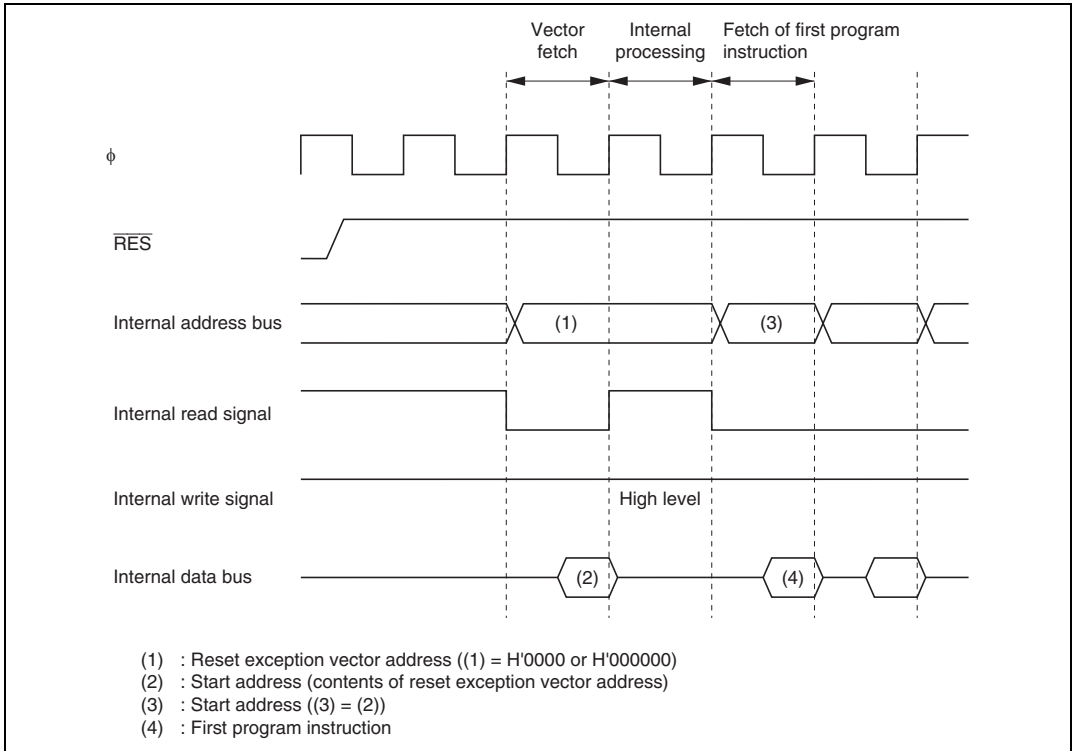
To ensure that the chip is reset, hold the  $\overline{\text{RES}}$  pin low during the oscillation stabilizing time of the clock oscillator when powering on. To reset the chip during operation, hold the  $\overline{\text{RES}}$  pin low for at least 20 states. For pin states in a reset, see appendix D.1, Pin Circuit Diagrams.

When the  $\overline{\text{RES}}$  pin goes high after being held low for the necessary time, the chip starts reset exception handling as follows:

- [1] The internal state of the CPU and the registers of the on-chip supporting modules are initialized, and the I bit is set to 1 in CCR.
- [2] The reset exception vector address is read and transferred to the PC, and program execution starts from the address indicated by the PC.

Figures 5.2 shows examples of the reset sequence.





**Figure 5.2 Reset Sequence (Mode 1)**

### 5.2.3 Interrupts after Reset

If an interrupt is accepted after a reset but before the stack pointer (SP) is initialized, the PC and CCR will not be saved correctly, leading to a program crash. To prevent this, all interrupt requests, including NMI, are disabled immediately after a reset. Since the first instruction of a program is always executed immediately after the reset state ends, make sure that this instruction initializes the stack pointer (example: `MOV.L #xx:32, SP`).

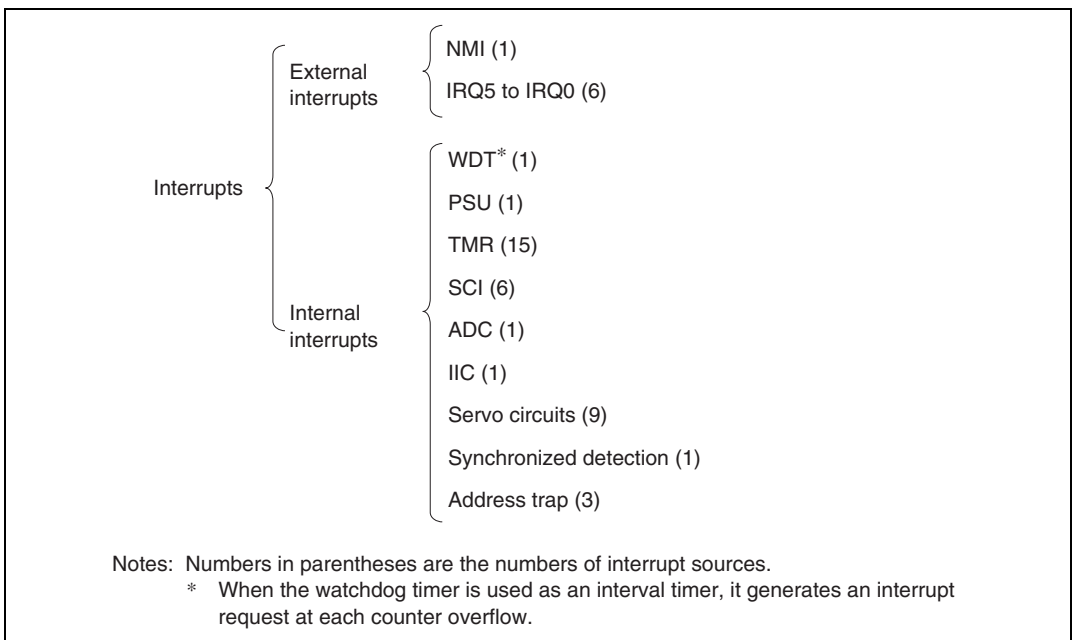
### 5.3 Interrupts

Interrupt exception handling can be requested by seven external sources (NMI and IRQ5 to IRQ0) and internal sources in the on-chip supporting modules. Figure 5.3 shows the interrupt sources and the number of interrupts of each type.

The on-chip supporting modules that can request interrupts include the watchdog timer (WDT), prescaler unit (PSU), Timers A, B, J, L, R and X1 (TMR), serial communication interface (SCI), A/D converter (ADC), I<sup>2</sup>C bus interface (IIC), servo circuits, synchronized detection, address trap, etc. Each interrupt source has a separate vector address.

NMI is the highest-priority interrupt. Interrupts are controlled by the interrupt controller. The interrupt controller has two interrupt control modes and can assign interrupts other than NMI to either three priority/mask levels to enable multiplexed interrupt control.

For details on interrupts, see section 6, Interrupt Controller.



**Figure 5.3 Interrupt Sources and Number of Interrupts**

## 5.4 Trap Instruction

Trap instruction exception handling starts when a TRAPA instruction is executed. Trap instruction exception handling can be executed at all times in the program execution state.

The TRAPA instruction fetches a start address from a vector table entry corresponding to a vector number from 0 to 3, as specified in the instruction code.

Table 5.3 shows the status of CCR and EXR after execution of trap instruction exception handling.

**Table 5.3 Status of CCR and EXR after Trap Instruction Exception Handling**

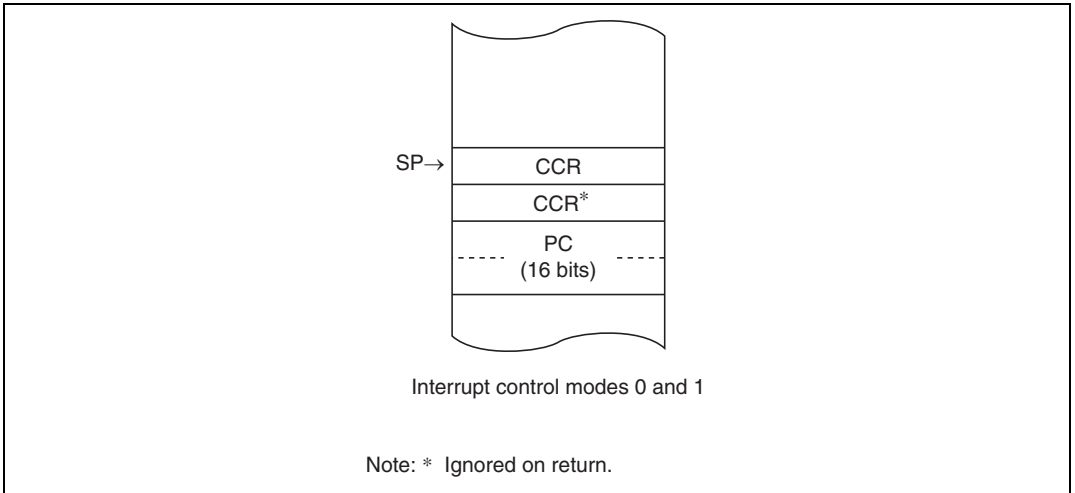
Interrupt Control Mode	CCR		EXR*	
	I	UI	I2 to I0	T
0	1	—	—	—
1	1	1	—	—

Legend:

- 1: Set to 1
- 0: Cleared to 0
- : Retains value prior to execution.
- \*: Does not affect operation in this LSI.

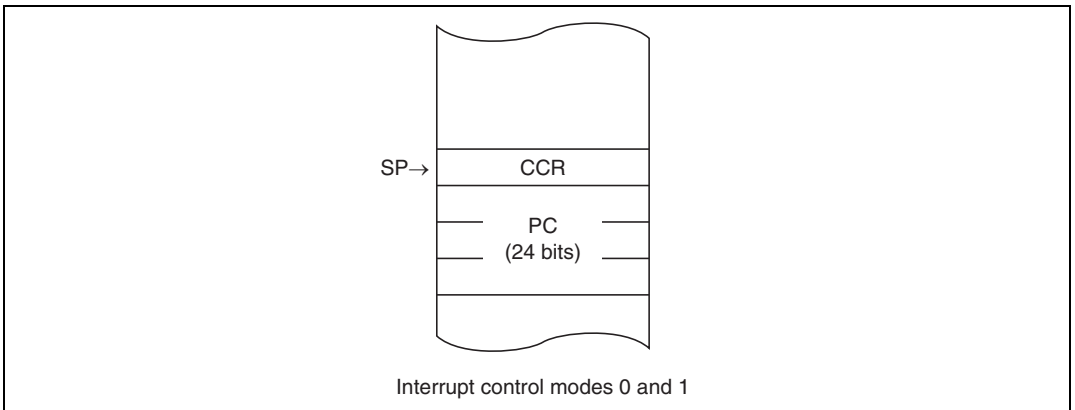
## 5.5 Stack Status after Exception Handling

Figure 5.4 shows the stack after completion of trap instruction exception handling and interrupt exception handling.



**Figure 5.4 (1) Stack Status after Exception Handling (Normal Mode)\***

Note: \* Normal mode is not available for this LSI.



**Figure 5.4 (2) Stack Status after Exception Handling (Advanced Mode)**

## 5.6 Notes on Use of the Stack

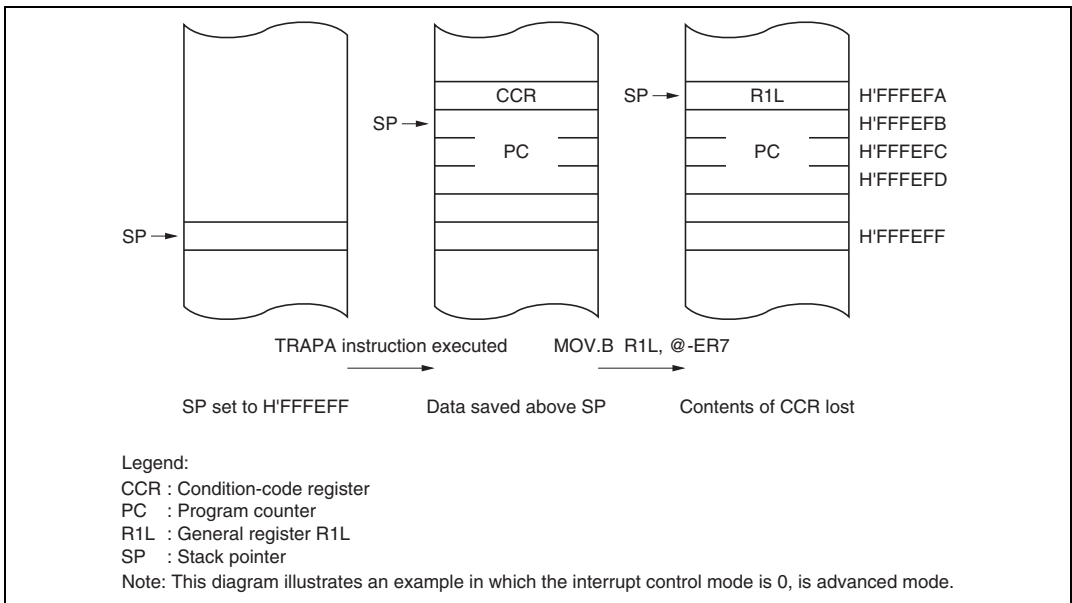
When accessing word data or longword data, this chip assumes that the lowest address bit is 0. The stack should always be accessed by word transfer instruction or longword transfer instruction, and the value of the stack pointer (SP: ER7) should always be kept even. Use the following instructions to save registers:

```
PUSH.W  Rn  (or MOV.W Rn,  @-SP)
PUSH.L  ERn (or MOV.L ERn,  @-SP)
```

Use the following instructions to restore registers:

```
POP.WRn (or MOV.W @SP+, Rn)
POP.LERn (or MOV.L @SP+, ERn)
```

Setting SP to an odd value may lead to a malfunction. Figure 5.5 shows an example of what happens when the SP value is odd.



**Figure 5.5 Operation when SP Value Is Odd**



---

## Section 6 Interrupt Controller

### 6.1 Overview

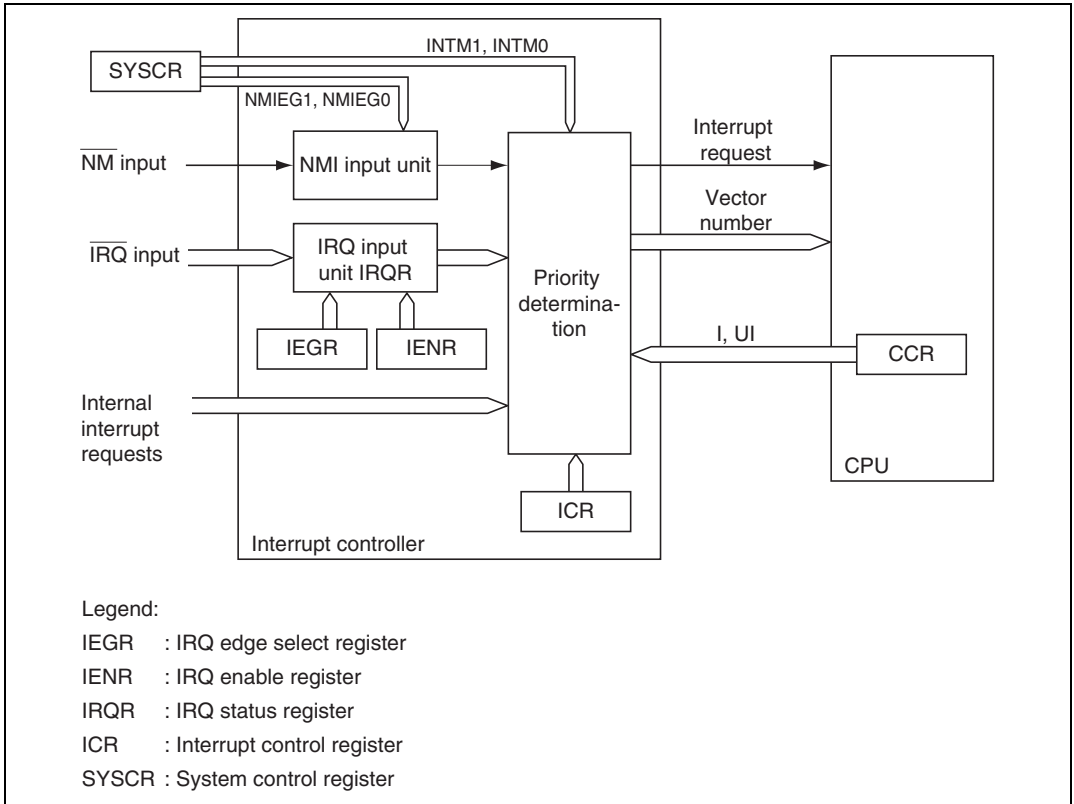
#### 6.1.1 Features

This LSI controls interrupts by means of an interrupt controller. The interrupt controller has the following features:

- Two Interrupt Control Modes
  - Either of two interrupt control modes can be set by means of the INTM1 and INTM0 bits in the system control register (SYSCR).
- Priorities Settable with ICR
  - An interrupt control register (ICR) is provided for setting interrupt priorities. Three priority levels can be set for each module for all interrupts except NMI.
- Independent Vector Addresses
  - All interrupt sources are assigned independent vector addresses, making it unnecessary for the source to be identified in the interrupt handling routine.
- Seven External Interrupt Pins
  - NMI is the highest-priority interrupt, and is accepted at all times. Falling edge, rising edge, or both edge detection can be selected for the NMI interrupt.
  - Falling edge, rising edge, or both edge detection can be selected for interrupt IRQ0.
  - Falling edge or rising edge can be individually selected for interrupts IRQ5 to IRQ1.

### 6.1.2 Block Diagram

A block diagram of the interrupt controller is shown in figure 6.1.



**Figure 6.1 Block Diagram of Interrupt Controller**



### 6.1.3 Pin Configuration

Table 6.1 summarizes the pins of the interrupt controller.

**Table 6.1 Interrupt Controller Pins**

Name	Symbol	I/O	Function
Nonmaskable interrupt	$\overline{\text{NMI}}$	Input	Nonmaskable external interrupt; rising, falling, or both edges can be selected
External interrupt request	$\overline{\text{IRQ0}}$	Input	Maskable external interrupts; rising, falling, or both edges can be selected
External interrupt requests 1 to 5	$\overline{\text{IRQ1}}$ to $\overline{\text{IRQ5}}$	Input	Maskable external interrupts: rising, or falling edges can be selected

### 6.1.4 Register Configuration

Table 6.2 summarizes the registers of the interrupt controller.

**Table 6.2 Interrupt Controller Registers**

Name	Abbreviation	R/W	Initial Value	Address <sup>*1</sup>
System control register	SYSCR	R/W	H'00	H'FFE8
IRQ edge select register	IEGR	R/W	H'00	H'FFF0
IRQ enable register	IENR	R/W	H'00	H'FFF1
IRQ status register	IRQR	R/ (W) <sup>*2</sup>	H'00	H'FFF2
Interrupt control register A	ICRA	R/W	H'00	H'FFF3
Interrupt control register B	ICRB	R/W	H'00	H'FFF4
Interrupt control register C	ICRC	R/W	H'00	H'FFF5
Interrupt control register D	ICRD	R/W	H'00	H'FFF6
Port mode register 1	PMR1	R/W	H'00	H'FFCE

- Notes: 1. Lower 16 bits of the address.  
 2. Only 0 can be written, for flag clearing.

## 6.2 Register Descriptions

### 6.2.1 System Control Register (SYSCR)

Bit :	7	6	5	4	3	2	1	0
	—	—	INTM1	INTM0	XRST	NMIEG1	NMIEG0	—
Initial value :	0	0	0	0	0	0	0	0
R/W :	—	—	R/W	R/W	R	R/W	R/W	—

SYSCR is an 8-bit readable register that selects the interrupt control mode and the detected edge for  $\overline{\text{NMI}}$ .

Only bits 5, 4, 2 and 1 are described here; for details on the other bits, see section 3.2.2, System Control Register (SYSCR).

SYSCR is initialized to H'00 by a reset.

**Bits 5 and 4—Interrupt Control Mode (INTM1, INTM0):** These bits select one of two interrupt control modes for the interrupt controller. The INTM1 bit must not be set to 1.

Bit 5	Bit 4	Interrupt Control Mode	Description
INTM1	INTM0		
0	0	0	Interrupts are controlled by I bit (Initial value)
	1	1	Interrupts are controlled by I and UI bits and ICR
1	0	—	Cannot be used in this LSI
	1	—	Cannot be used in this LSI

**Bits 2 and 1— $\overline{\text{NMI}}$  Pin Detected Edge Select (NMIEG1, NMIEG0):** Selects the detected edge for the  $\overline{\text{NMI}}$  pin.

Bit 2	Bit 1	Description
NMIEG1	NMIEG0	
0	0	Interrupt request generated at falling edge of $\overline{\text{NMI}}$ pin (Initial value)
	1	Interrupt request generated at rising edge of $\overline{\text{NMI}}$ pin
1	*	Interrupt request generated at both falling and rising edges of $\overline{\text{NMI}}$ pin

Legend: \* Don't care

## 6.2.2 Interrupt Control Registers A to D (ICRA to ICRD)

Bit :	7	6	5	4	3	2	1	0
	ICR7	ICR6	ICR5	ICR4	ICR3	ICR2	ICR1	ICR0
Initial value :	0	0	0	0	0	0	0	0
R/W :	R/W	R/W	R/W	R/W	R/W	R/W	R/W	R/W

The ICR registers are four 8-bit readable/writable registers that set the interrupt control level for interrupts other than NMI.

The correspondence between ICR settings and interrupt sources is shown in table 6.3.

The ICR registers are initialized to H'00 by a reset.

**Bits 7 to 0—Interrupt Control Level (ICR7 to ICR0):** Sets the control level for the corresponding interrupt source.

### Bit n

ICRn	Description
0	Corresponding interrupt source is control level 0 (non-priority) (Initial value)
1	Corresponding interrupt source is control level 1 (priority)

Note: n = 7 to 0

**Table 6.3 Correspondence between Interrupt Sources and ICR Settings**

ICRA	ICRA7	ICRA6	ICRA5	ICRA4	ICRA3	ICRA2	ICRA1	ICRA0
	Reserved	Input capture	HSW1	IRQ0	IRQ1	IRQ2 IRQ3	IRQ4 IRQ5	Reserved
ICRB	ICRB7	ICRB6	ICRB5	ICRB4	ICRB3	ICRB2	ICRB1	ICRB0
	Reserved	Reserved	Servo (drum, capstan latch)	Timer A	Timer B	Timer J	Timer R	Timer L
ICRC	ICRC7	ICRC6	ICRC5	ICRC4	ICRC3	ICRC2	ICRC1	ICRC0
	Timer X1	Synchronized detection	Watchdog timer	Servo	IIC	SCI1 (UART)	SCI2 (with 32-bit buffer)	A/D
ICRD	ICRD7	ICRD6	ICRD5	ICRD4	ICRD3	ICRD2	ICRD1	ICRD0
	HSW2	Reserved	Reserved	Reserved	Reserved	Reserved	Reserved	Reserved

### 6.2.3 IRQ Enable Register (IENR)

Bit :	7	6	5	4	3	2	1	0
	—	—	IRQ5E	IRQ4E	IRQ3E	IRQ2E	IRQ1E	IRQ0E
Initial value :	0	0	0	0	0	0	0	0
R/W :	—	—	R/W	R/W	R/W	R/W	R/W	R/W

IENR is an 8-bit readable/writable register that controls enabling and disabling of interrupt requests IRQ5 to IRQ0.

IENR is initialized to H'00 by a reset.

**Bits 7 and 6—Reserved:** Do not write 1 to them.

**Bits 5 to 0—IRQ5 to IRQ0 Enable (IRQ5E to IRQ0E):** These bits select whether IRQ5 to IRQ0 are enabled or disabled.

#### Bit n

IRQnE	Description
0	IRQn interrupt disabled (Initial value)
1	IRQn interrupt enabled

Note: n = 5 to 0

### 6.2.4 IRQ Edge Select Registers (IEGR)

Bit :	7	6	5	4	3	2	1	0
	—	IRQ5EG	IRQ4EG	IRQ3EG	IRQ2EG	IRQ1EG	IRQ0EG1	IRQ0EG0
Initial value :	0	0	0	0	0	0	0	0
R/W :	—	R/W	R/W	R/W	R/W	R/W	R/W	R/W

IEGR is an 8-bit readable/writable register that selects detected edge of the input at pins  $\overline{\text{IRQ5}}$  to  $\overline{\text{IRQ0}}$ .

IEGR register is initialized to H'00 by a reset.

**Bit 7—Reserved:** Do not write 1 to it.

**Bits 6 to 2— $\overline{\text{IRQ5}}$  to  $\overline{\text{IRQ1}}$  Pins Detected Edge Select (IRQ5EG to IRQ1EG):** These bits select detected edge for interrupts IRQ5 to IRQ1.

### Bits 6 to 2

IRQnEG	Description
0	Interrupt request generated at falling edge of $\overline{\text{IRQn}}$ pin input (Initial value)
1	Interrupt request generated at rising edge of $\overline{\text{IRQn}}$ pin input

Note: n = 5 to 1

**Bits 1 and 0— $\overline{\text{IRQ0}}$  Pin Detected Edge Select (IRQ0EG1, IRQ0EG0):** These bits select detected edge for interrupt IRQ0.

Bit 1	Bit 0	Description
0	0	Interrupt request generated at falling edge of $\overline{\text{IRQ0}}$ pin input (Initial value)
0	1	Interrupt request generated at rising edge of $\overline{\text{IRQ0}}$ pin input
1	*	Interrupt request generated at both falling and rising edges of $\overline{\text{IRQ0}}$ pin input

Legend: \* Don't care

### 6.2.5 IRQ Status Register (IRQR)

Bit :	7	6	5	4	3	2	1	0
	—	—	IRQ5F	IRQ4F	IRQ3F	IRQ2F	IRQ1F	IRQ0F
Initial value :	0	0	0	0	0	0	0	0
R/W :	—	—	R/(W)*	R/(W)*	R/(W)*	R/(W)*	R/(W)*	R/(W)*

Note: \* Only 0 can be written, to clear the flag.

IRQR is an 8-bit readable/writable register that indicates the status of IRQ5 to IRQ0 interrupt requests.

IRQR is initialized to H'00 by a reset.

**Bits 7 and 6—Reserved:** Do not write 1 to them.

**Bits 5 to 0—IRQ5 to IRQ0 Flags:** These bits indicate the status of IRQ5 to IRQ0 interrupt requests.

**Bit n**

<b>IRQnF</b>	<b>Description</b>	
0	[Clearing condition] Cleared by reading IRQnF set to 1, then writing 0 in IRQnF When IRQn interrupt exception handling is executed	(Initial value)
1	[Setting conditions] (1) When a falling edge occurs in IRQn input while falling edge detection is set (IRQnEG = 0) (2) When a rising edge occurs in IRQn input while rising edge detection is set (IRQnEG = 0) (3) When a falling or rising edge occurs in IRQ0 input while both-edge detection is set (IRQ0EG1 = 1)	

Note: n = 5 to 0

### 6.2.6 Port Mode Register (PMR1)

Bit :	7	6	5	4	3	2	1	0
	PMR17	PMR16	PMR15	PMR14	PMR13	PMR12	PMR11	PMR10
Initial value :	0	0	0	0	0	0	0	0
R/W :	R/W	R/W	R/W	R/W	R/W	R/W	R/W	R/W

Port Mode Register 1 (PMR1) controls pin function switching-over of port 1. Switching is specified for each bit.

PMR1 is an 8-bit readable/writable register and is initialized to H'00 by a reset.

Only bits 5 to 0 are explained here. For details, see section 11, I/O Port.

**Bits 5 to 0—P1n/ $\overline{\text{IRQn}}$  to P10/ $\overline{\text{IRQ0}}$  Pin Switching (PMR15 to PMR10):** These bits are for setting the P1n/ $\overline{\text{IRQn}}$  pin as the input/output pin for P1n or as the  $\overline{\text{IRQn}}$  pin for external interrupt request input.

**Bit n**

<b>PMR1n</b>	<b>Description</b>	
0	P1n/ $\overline{\text{IRQn}}$ pin functions as the P1n input/output pin	(Initial value)
1	P1n/ $\overline{\text{IRQn}}$ pin functions as the $\overline{\text{IRQn}}$ input pin	

Note: n = 5 to 0

The following is the notes on switching the pin function by PMR1.

- (1) When the port is set as the  $\overline{IC}$  input pin or  $\overline{IRQ5}$  to  $\overline{IRQ0}$  input pin, the pin level must be High or Low regardless of active mode or power-down mode. Do not set the pin level at Medium.
- (2) Switching the pin function of P16/ $\overline{IC}$  or P15/ $\overline{IRQ5}$  to P10/ $\overline{IRQ0}$  may be mistakenly identified as edge detection and detection signal may be generated. To prevent this, operate as follows:
  - (a) Set the interrupt enable/disable flag to disable before switching the pin function.
  - (b) Clear the applicable interrupt request flag to 0 after switching the pin function and executing another instruction.

(Program example)

```

:
MOV.B R0L, @IENR ..... Interrupt disabled
MOV.B R1L, @PMR1 ..... Pin function change
NOP ..... Optional instruction
BCLR m @IRQR ..... Applicable interrupt clear
MOV.B R1L, @IENR ..... Interrupt enabled
:

```

## 6.3 Interrupt Sources

Interrupt sources comprise external interrupts (NMI and IRQ5 to IRQ0) and internal interrupts.

### 6.3.1 External Interrupts

There are seven external interrupt sources; NMI and IRQ5 to IRQ0. Of these, NMI, and IRQ1 to IRQ0 can be used to restore this chip from standby mode.

#### (1) NMI Interrupt

NMI is the highest-priority interrupt, and is always accepted by the CPU regardless of the interrupt control mode and the status of the CPU interrupt mask bits. The NMIEG1 and NMIEG0 bits in SYSCR can be used to select whether an interrupt is requested at a rising, falling edge or both edges on the  $\overline{\text{NMI}}$  pin.

The vector number for NMI interrupt exception handling is 7.

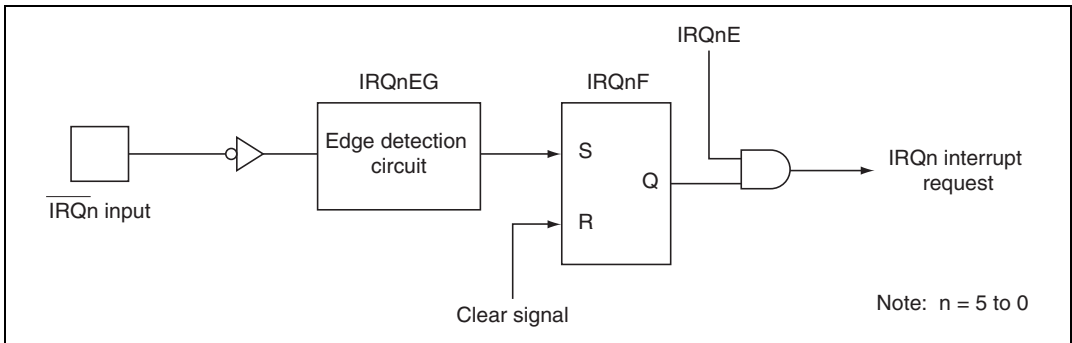
#### (2) IRQ5 to IRQ0 Interrupts

Interrupts IRQ5 to IRQ0 are requested by an input signal at pins  $\overline{\text{IRQ5}}$  to  $\overline{\text{IRQ0}}$ . Interrupts IRQ5 to IRQ0 have the following features:

- (a) Using IEGR, it is possible to select whether an interrupt is generated by a low level, falling edge, rising edge, or both edges, at pin  $\overline{\text{IRQ0}}$ .
- (b) Using IEGR, it is possible to select whether an interrupt is generated by a low level, falling edge, rising edge, or both edges, at pins  $\overline{\text{IRQ5}}$  to  $\overline{\text{IRQ0}}$ .
- (c) Enabling or disabling of interrupt requests IRQ5 to IRQ0 can be selected with IENR.
- (d) The interrupt control level can be set with ICR.
- (e) The status of interrupt requests IRQ5 to IRQ0 is indicated in IRQR. IRQR flags can be cleared to 0 by software.

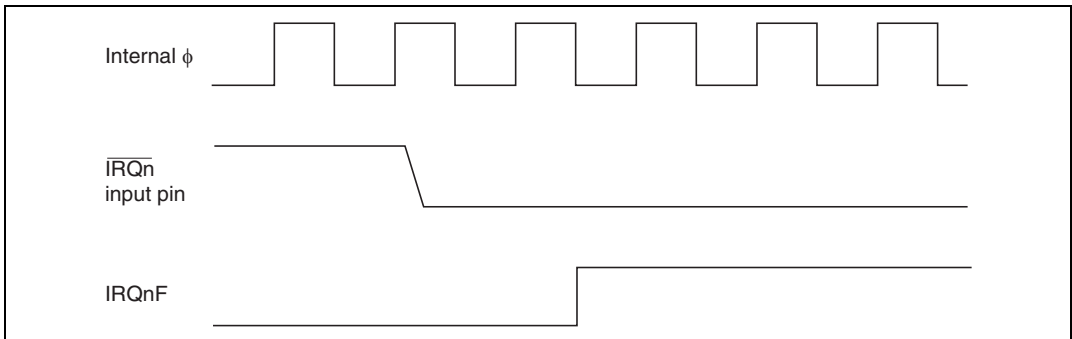
A block diagram of interrupts IRQ5 to IRQ0 is shown in figure 6.2.





**Figure 6.2 Block Diagram of Interrupts IRQ5 to IRQ0**

Figure 6.3 shows the timing of  $\text{IRQnF}$  setting.



**Figure 6.3 Timing of  $\text{IRQnF}$  Setting**

The vector numbers for IRQ5 to IRQ0 interrupt exception handling are 21 to 26.

Upon detection of IRQ5 to IRQ0 interrupts, the applicable pin is set in the port mode register 1 (PMR1) as  $\overline{\text{IRQn}}$  pin.

### 6.3.2 Internal Interrupts

There are 38 sources for internal interrupts from on-chip supporting modules.

- (1) For each on-chip supporting module there are flags that indicate the interrupt request status, and enable bits that select enabling or disabling of these interrupts. If any one of these is set to 1, an interrupt request is issued to the interrupt controller.
- (2) The interrupt control level can be set by means of ICR.

### 6.3.3 Interrupt Exception Vector Table

Table 6.4 shows interrupt exception handling sources, vector addresses, and interrupt priorities. For default priorities, the lower the vector number, the higher the priority. Priorities among modules can be set by means of ICR. The situation when two or more modules are set to the same priority, and priorities within a module, are fixed as shown in table 6.4.

**Table 6.4 Interrupt Sources, Vector Addresses, and Interrupt Priorities**

Priority	Interrupt Source	Origin of Interrupt Source	Vector No.	Vector Address	ICR	Remarks	
High ↑ Low	Reset	External pin	0	H'0000 to H'0003	—		
	Reserved	—	—	1	H'0004 to H'0007	—	
		—	—	2	H'0008 to H'000B	—	
		—	—	3	H'000C to H'000F	—	
		—	—	4	H'0010 to H'0013	—	
		—	—	5	H'0014 to H'0017	—	
	Direct transition	Instruction	6	H'0018 to H'001B	—		
	NMI	External pin	7	H'001C to H'001F	—		
	Trap instruction	TRAPA#0	Instruction	8	H'0020 to H'0023	—	
		TRAPA#1		9	H'0024 to H'0027	—	
		TRAPA#2		10	H'0028 to H'002B	—	
		TRAPA#3		11	H'002C to H'002F	—	
	Reserved	—	—	12	H'0030 to H'0033	—	
		—	—	13	H'0034 to H'0037	—	
		—	—	14	H'0038 to H'003B	—	
—		—	15	H'003C to H'003F	—		

Priority	Interrupt Source	Origin of Interrupt Source	Vector No.	Vector Address	ICR	Remarks
High	Address trap	#0	ATC	16	H'0040 to H'0043	—
				17	H'0044 to H'0047	
				18	H'0048 to H'004B	
	IC	PSU	19	H'004C to H'004F	ICRA6	
	HSW1	Servo circuit	20	H'0050 to H'0053	ICRA5	
	IRQ0	External pin	21	H'0054 to H'0057	ICRA4	
	IRQ1		22	H'0058 to H'005B	ICRA3	
	IRQ2		23	H'005C to H'005F	ICRA2	
	IRQ3		24	H'0060 to H'0063		
	IRQ4		25	H'0064 to H'0067	ICRA1	
	IRQ5		26	H'0068 to H'006B		
	Reserved	—	27	H'006C to H'006F	—	
			28	H'0070 to H'0073		
			29	H'0074 to H'0077		
			30	H'0078 to H'007B		
			31	H'007C to H'007F		
			32	H'0080 to H'0083		
			33	H'0084 to H'0087		
	Drum latch 1 (speed)	Servo circuit	34	H'0088 to H'008B	ICRB5	
	Capstan latch 1 (speed)		35	H'008C to H'008F		
	TMAI	Timer A	36	H'0090 to H'0093	ICRB4	
	TMBI	Timer B	37	H'0094 to H'0097	ICRB3	
	TMJ1I	Timer J	38	H'0098 to H'009B	ICRB2	
	TMJ2I		39	H'009C to H'009F		
	TMR1I	Timer R	40	H'00A0 to H'00A3	ICRB1	
	TMR2I		41	H'00A4 to H'00A7		
	TMR3I		42	H'00A8 to H'00AB		
Low	TMLI	Timer L	43	H'00AC to H'00AF	ICRB0	

Priority	Interrupt Source	Origin of Interrupt Source	Vector No.	Vector Address	ICR	Remarks
High ↑	ICXA	Timer X1	44	H'00B0 to H'00B3	ICRC7	
	ICXB		45	H'00B4 to H'00B7		
	ICXC		46	H'00B8 to H'00BB		
	ICXD		47	H'00BC to H'00BF		
	OCX1		48	H'00C0 to H'00C3		
	OCX2		49	H'00C4 to H'00C7		
	OVFX		50	H'00C8 to H'00CB		
	VD interrupts	Sync signal detection	51	H'00CC to H'00CF		ICRC6
	Reserved	—	52	H'00D0 to H'00D3		
	8-bit interval timer	Watchdog timer	53	H'00D4 to H'00D7		ICRC5
CTL	Servo circuit	54	H'00D8 to H'00DB	ICRC4		
Drum latch 2 (speed)		55	H'00DC to H'00DF			
Capstan latch 2 (speed)		56	H'00E0 to H'00E3			
Drum latch 3 (phase)		57	H'00E4 to H'00D7			
Capstan latch 3 (phase)		58	H'00E8 to H'00EB			
IIC	IIC	59	H'00EC to H'00EF	ICRC3		
SCI1	ERI	SCI1 (UART)	60	H'00F0 to H'00F3	ICRC2	
	RXI		61	H'00F4 to H'00F7		
	TXI		62	H'00F8 to H'00FB		
	TEI		63	H'00FC to H'00FF		
SCI2	TEI	SCI2	64	H'0100 to H'0103	ICRC1	
	ABTI		65	H'0104 to H'0107		
	A/D conversion end	A/D	66	H'0108 to H'010B	ICRC0	
Low	HSW2	Servo circuit	67	H'010C to H'010F	ICRD7	

## 6.4 Interrupt Operation

### 6.4.1 Interrupt Control Modes and Interrupt Operation

Interrupt operations in this LSI differ depending on the interrupt control mode.

NMI interrupts and address trap interrupts are accepted at all times except in the reset state. In the case of IRQ interrupts and on-chip supporting module interrupts, an enable bit is provided for each interrupt. Clearing an enable bit to 0 disables the corresponding interrupt request. Interrupt sources for which the enable bits are set to 1 are controlled by the interrupt controller.

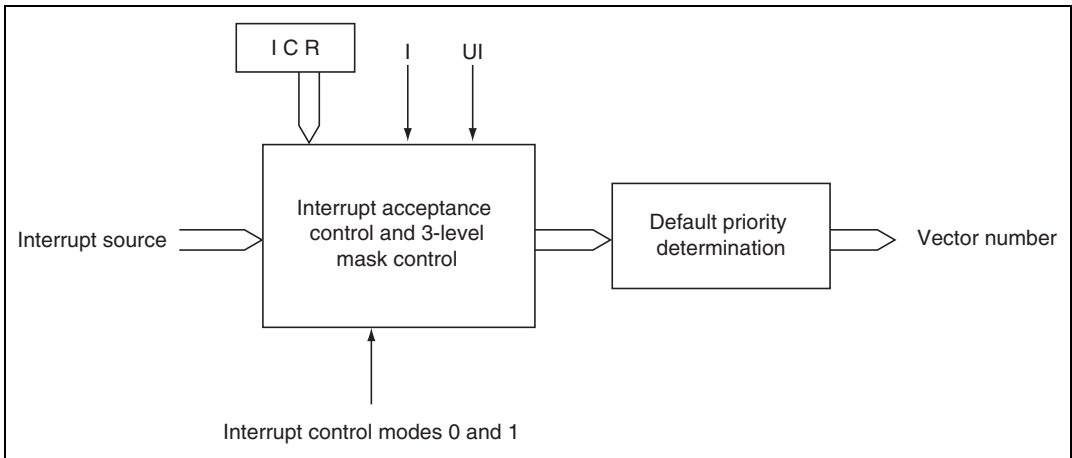
Table 6.5 shows the interrupt control modes.

The interrupt controller performs interrupt control according to the interrupt control mode set by the INTM1 and INTM0 bits in SYSCR, the priorities set in ICR, and the masking state indicated by the I and UI bits in the CPU's CCR.

**Table 6.5 Interrupt Control Modes**

Interrupt Control Mode	SYSCR		Priority Setting Register	Interrupt Mask Bits	Description
	INTM1	INTM0			
0	0	0	ICR	I	Interrupt mask control is performed by the I bit Priority can be set with ICR
1		1	ICR	I, UI	3-level interrupt mask control is performed by the I and UI bits Priority can be set with ICR

Figure 6.4 shows a block diagram of the priority decision circuit.



**Figure 6.4 Block Diagram of Interrupt Priority Determination Operation**

### (1) Interrupt Acceptance Control and 3-Level Control

In interrupt control modes 0 and 1, interrupt acceptance control and 3-level mask control is performed by means of the I and UI bits in CCR, and ICR (control level).

Table 6.6 shows the interrupts selected in each interrupt control mode.

**Table 6.6 Interrupts Selected in Each Interrupt Control Mode**

Interrupt Control Mode	Interrupt Mask Bit		Selected Interrupts
	I	UI	
0	0	*	All interrupts (control level 1 has priority)
	1	*	NMI and address trap interrupts
1	0	*	All interrupts (control level 1 has priority)
	1	0	NMI, address trap and control level 1 interrupts
		1	NMI and address trap interrupts

Legend: \* Don't care

### (2) Default Priority Determination

The priority is determined for the selected interrupt, and a vector number is generated.

If the same value is set for ICR, acceptance of multiple interrupts is enabled, and so only the interrupt source with the highest priority according to the preset default priorities is selected and has a vector number generated.

Interrupt sources with a lower priority than the accepted interrupt source are held pending.

Table 6.7 shows operations and control signal functions in each interrupt control mode.

**Table 6.7 Operations and Control Signal Functions in Each Interrupt Control Mode**

Interrupt Control Mode	Setting		Interrupt Acceptance Control, 3-Level Control				Default Priority Determination
	INTM1	INTM0	I	UI	ICR		
0	0	0	○	IM	—	PR	○
1		1	○	IM	IM	PR	○

Legend:

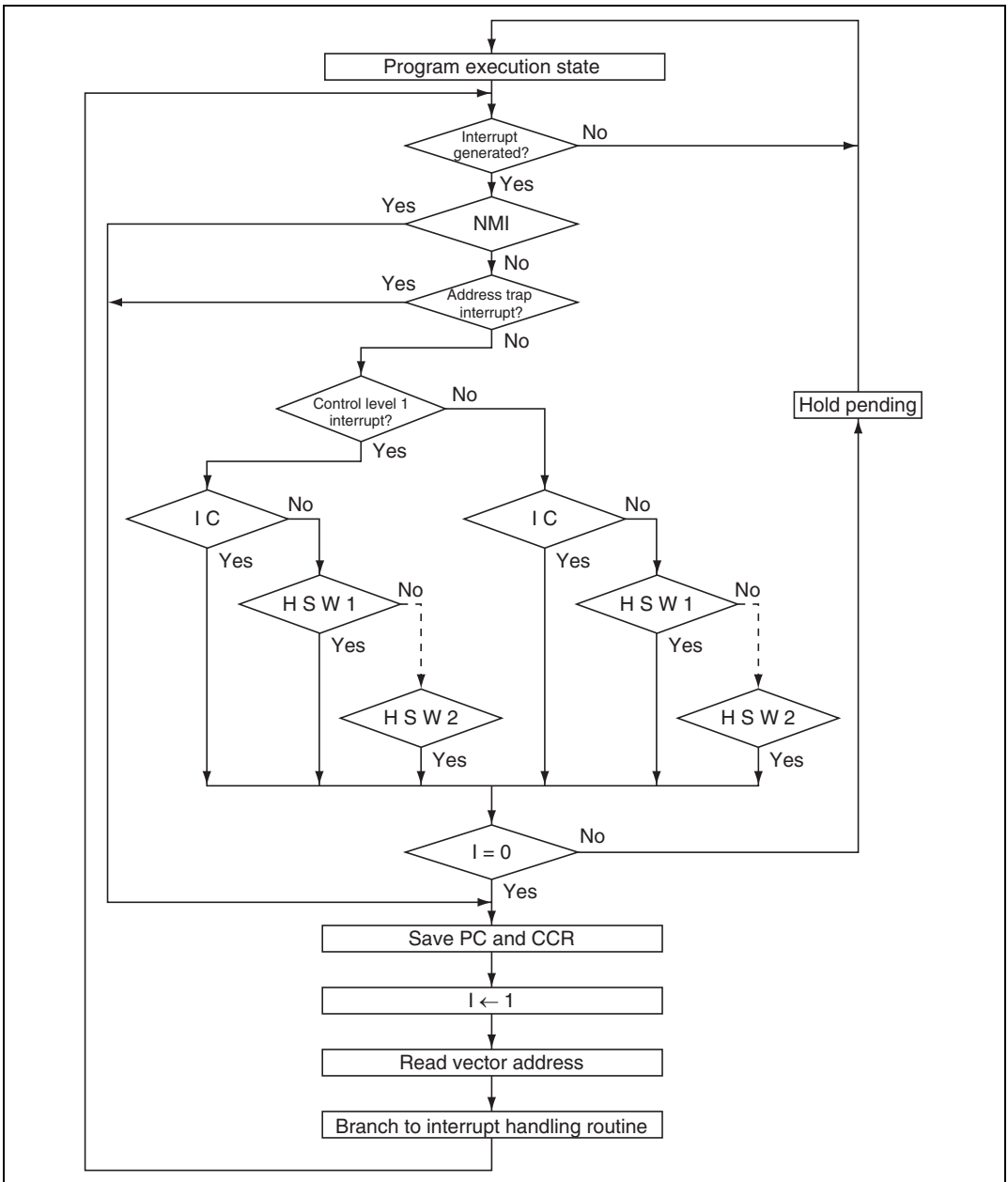
- : Interrupt operation control performed
- IM: Used as interrupt mask bit
- PR: Sets priority
- : Not used

### 6.4.2 Interrupt Control Mode 0

Enabling and disabling of IRQ interrupts and on-chip supporting module interrupts can be set by means of the I bit in the CPU's CCR, and ICR. Interrupts are enabled when the I bit is cleared to 0, and disabled when set to 1. Control level 1 interrupt sources have higher priority.

Figure 6.5 shows a flowchart of the interrupt acceptance operation in this case.

- (1) If an interrupt source occurs when the corresponding interrupt enable bit is set to 1, an interrupt request is sent to the interrupt controller.
- (2) When interrupt requests are sent to the interrupt controller, a control level 1 interrupt, according to the control level set in ICR, has priority for selection, and other interrupt requests are held pending. If a number of interrupt requests with the same control level setting are generated at the same time, the interrupt request with the highest priority according to the priority system shown in table 6.4 is selected.
- (3) The I bit is then referenced. If the I bit is cleared to 0, the interrupt request is accepted. If the I bit is set to 1, only an NMI or an address trap interrupt is accepted, and other interrupt requests are held pending.
- (4) When an interrupt request is accepted, interrupt exception handling starts after execution of the current instruction has been completed.
- (5) The PC and CCR are saved to the stack area by interrupt exception handling. The PC saved on the stack shows the address of the first instruction to be executed after returning from the interrupt handling routine.
- (6) Next, the I bit in CCR is set to 1. This disables all interrupts except NMI and address trap.
- (7) A vector address is generated for the accepted interrupt, and execution of the interrupt handling routine starts at the address indicated by the contents of that vector address.



**Figure 6.5 Flowchart of Procedure Up to Interrupt Acceptance in Interrupt Control Mode 0**



### 6.4.3 Interrupt Control Mode 1

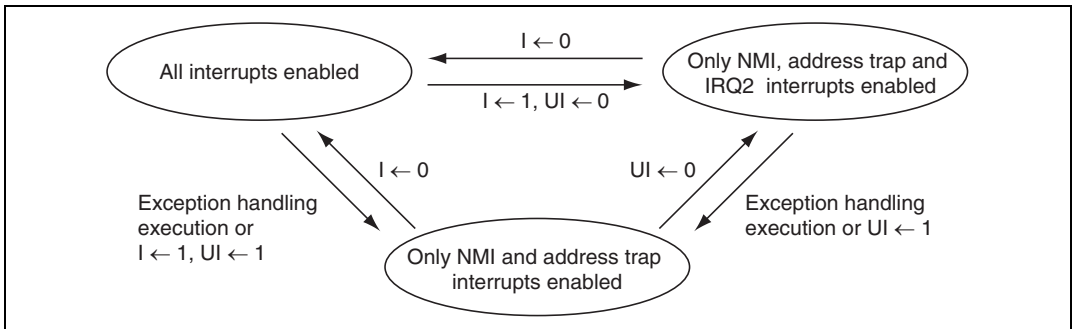
Three-level masking is implemented for IRQ interrupts and on-chip supporting module interrupts by means of the I and UI bits in the CPU's CCR, and ICR.

- (1) Control level 0 interrupt requests are enabled when the I bit is cleared to 0, and disabled when set to 1.
- (2) Control level 1 interrupt requests are enabled when the I bit or UI bit is cleared to 0, and disabled when both the I bit and the UI bit are set to 1.

For example, if the interrupt enable bit for an interrupt request is set to 1, and H'04, H'00, H'00 and H'00 are set in ICRA, ICRB, ICRC, and ICRD respectively, (i.e. IRQ2 interrupt is set to control level 1 and other interrupts to control level 0), the situation is as follows:

- (1) When  $I = 0$ , all interrupts are enabled  
(Priority order: NMI > IRQ2 > IC > HSW1 > ...)
- (2) When  $I = 1$  and  $UI = 0$ , only NMI, address trap and IRQ2 interrupts are enabled
- (3) When  $I = 1$  and  $UI = 1$ , only NMI and address trap interrupts are enabled

Figure 6.6 shows the state transitions in these cases.



**Figure 6.6 Example of State Transitions in Interrupt Control Mode 1**

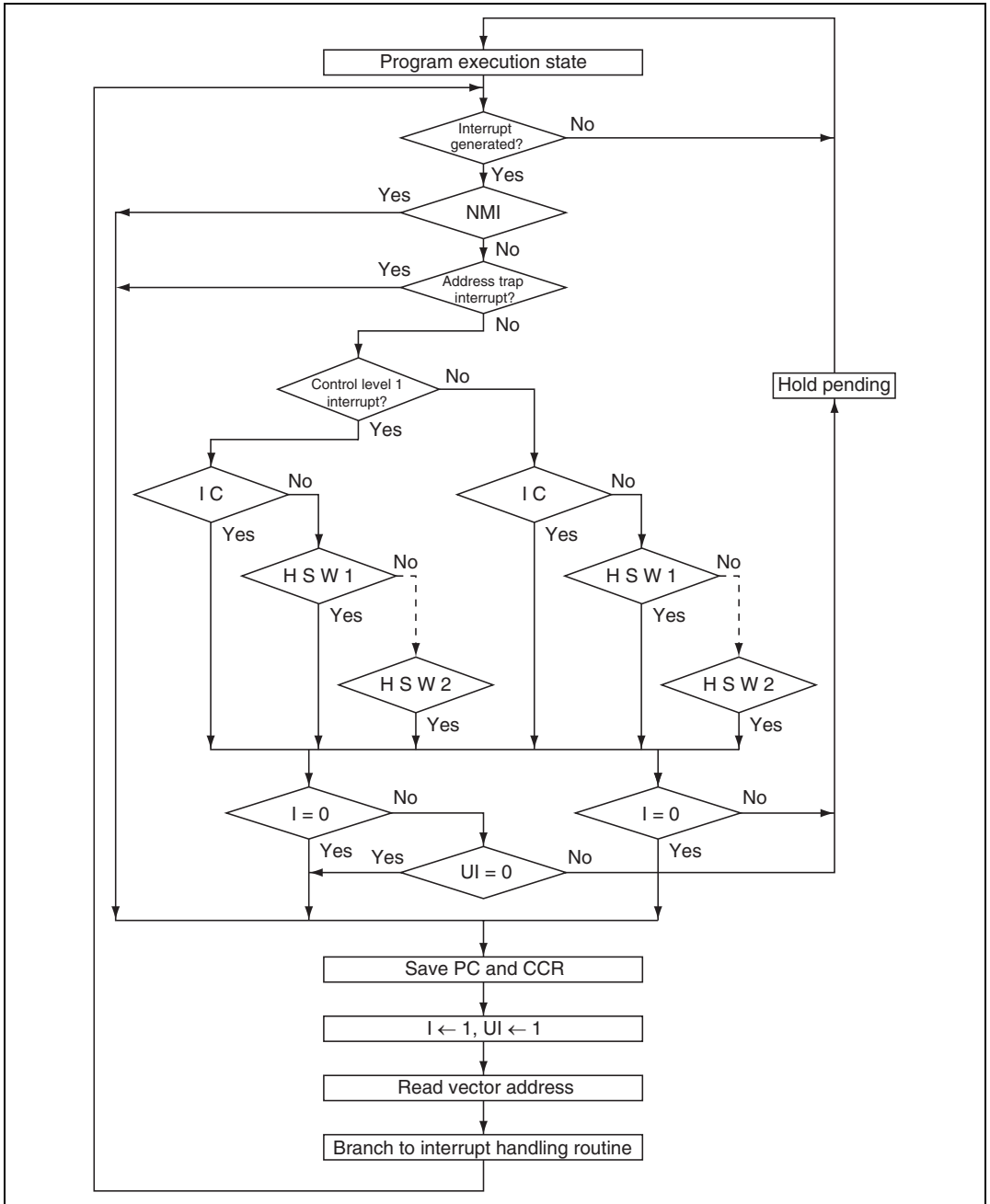
Figure 6.7 shows an operation flowchart of interrupt reception.

- (1) If an interrupt source occurs when the corresponding interrupt enable bit is set to 1, an interrupt request is sent to the interrupt controller.
- (2) When interrupt requests are sent to the interrupt controller, a control level 1 interrupt, according to the control level set in ICR, has priority for selection, and other interrupt requests are held pending. If a number of interrupt requests with the same control level setting are generated at the same time, the interrupt request with the highest priority according to the priority system shown in table 6.4 is selected.
- (3) The I bit is then referenced. If the I bit is cleared to 0, the UI bit has no effect.

An interrupt request set to interrupt control level 0 is accepted when the I bit is cleared to 0. If the I bit is set to 1, only NMI and address trap interrupts are accepted, and other interrupt requests are held pending.

An interrupt request set to interrupt control level 1 has priority over an interrupt request set to interrupt control level 0, and is accepted if the I bit is cleared to 0, or if the I bit is set to 1 and the UI bit is cleared to 0.

When both the I bit and the UI bit are set to 1, only NMI and address trap interrupts are accepted, and other interrupt requests are held pending.
- (4) When an interrupt request is accepted, interrupt exception handling starts after execution of the current instruction has been completed.
- (5) The PC and CCR are saved to the stack area by interrupt exception handling. The PC saved on the stack shows the address of the first instruction to be executed after returning from the interrupt handling routine.
- (6) Next, the I and UI bits in CCR are set to 1. This masks all interrupts except NMI and address trap.
- (7) A vector address is generated for the accepted interrupt, and execution of the interrupt handling routine starts at the address indicated by the contents of that vector address.



**Figure 6.7 Flowchart of Procedure Up to Interrupt Acceptance in Interrupt Control Mode 1**

### 6.4.4 Interrupt Exception Handling Sequence

Figure 6.8 shows the interrupt exception handling sequence. The example shown is for the case where interrupt control 0 is set in advanced mode, and the program area and stack area are in on-chip memory.

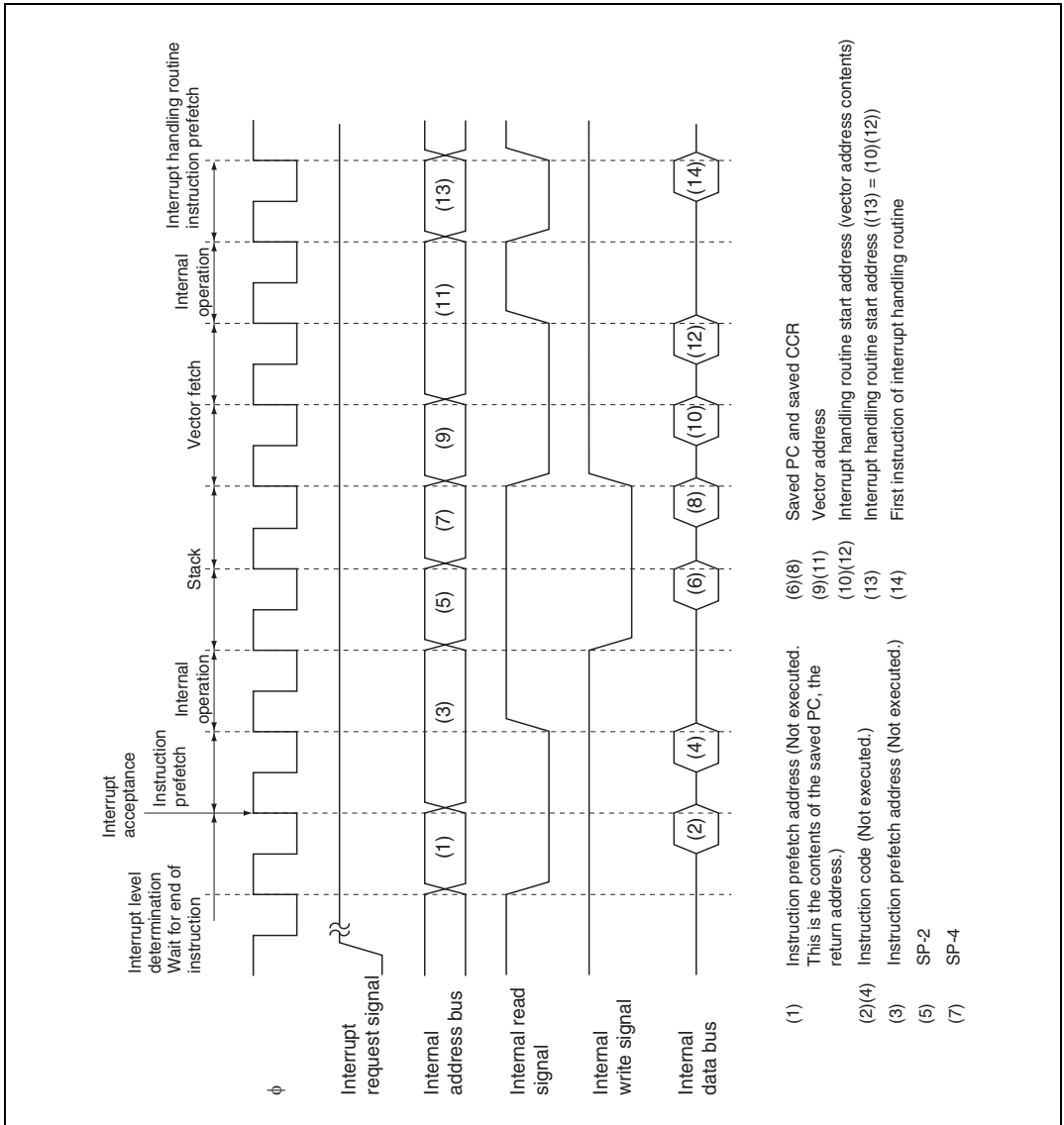


Figure 6.8 Interrupt Exception Handling

### 6.4.5 Interrupt Response Times

Table 6.8 shows interrupt response times—the interval between generation of an interrupt request and execution of the first instruction in the interrupt handling routine. The symbols used in table 6.8 are explained in table 6.9.

**Table 6.8 Interrupt Response Times**

No.	Number of States	Advanced Mode
1	Interrupt priority determination <sup>*1</sup>	3
2	Number of wait states until executing instruction ends <sup>*2</sup>	1 to 19 + 2 · S <sub>I</sub>
3	PC, CCR stack save	2 · S <sub>k</sub>
4	Vector fetch	2 · S <sub>I</sub>
5	Instruction fetch <sup>*3</sup>	2 · S <sub>I</sub>
6	Internal processing <sup>*4</sup>	2
Total (using on-chip memory)		12 to 32

- Notes:
1. Two states in case of internal interrupt.
  2. Refers to MULXS and DIVXS instructions.
  3. Prefetch after interrupt acceptance and interrupt handling routine prefetch.
  4. Internal processing after interrupt acceptance and internal processing after vector fetch.

**Table 6.9 Number of States in Interrupt Handling Routine Execution**

Symbol	Object of Access
	Internal Memory
Instruction fetch SI	1
Branch address read SJ	
Stack manipulation SK	

## 6.5 Usage Notes

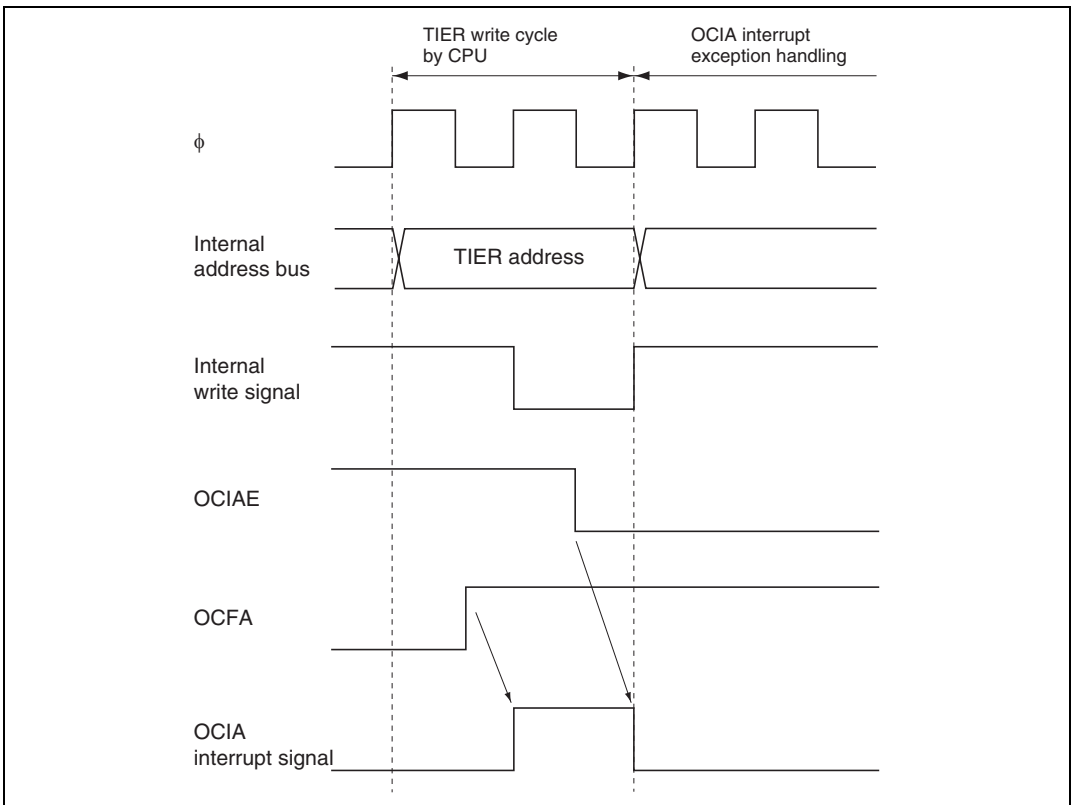
### 6.5.1 Contention between Interrupt Generation and Disabling

When an interrupt enable bit is cleared to 0 to disable interrupts, the disabling becomes effective after execution of the instruction.

In other words, when an interrupt enable bit is cleared to 0 by an instruction such as BCLR or MOV, if an interrupt is generated during execution of the instruction, the interrupt concerned will still be enabled on completion of the instruction, and so interrupt exception handling for that interrupt will be executed on completion of the instruction. However, if there is an interrupt request of higher priority than that interrupt, interrupt exception handling will be executed for the higher-priority interrupt, and the lower-priority interrupt will be ignored.

The same also applies when an interrupt source flag is cleared to 0.

Figure 6.9 shows an example in which the OCIAE bit in timer X1 TIER is cleared to 0.



**Figure 6.9 Contention between Interrupt Generation and Disabling**

The above contention will not occur if an enable bit or interrupt source flag is cleared to 0 while the interrupt is masked.

### 6.5.2 Instructions That Disable Interrupts

Instructions that disable interrupts are LDC, ANDC, ORC, and XORC. After any of these instructions is executed, all interrupts except NMI are disabled and the next instruction is always executed. When the I bit or UI bit is set by one of these instructions, the new value becomes valid two states after execution of the instruction ends.

### 6.5.3 Interrupts during Execution of EEPMOV Instruction

Interrupt operation differs between the EEPMOV.B instruction and the EEPMOV.W instruction. With the EEPMOV.B instruction, an interrupt request (including NMI) issued during the transfer is not accepted until the move is completed.

With the EEPMOV.W instruction, if an interrupt request is issued during the transfer, interrupt exception handling starts at a break in the transfer cycle. The PC value saved on the stack in this case is the address of the next instruction.

Therefore, if an interrupt is generated during execution of an EEPMOV.W instruction, the following coding should be used.

```
L1:  EEPMOV.W
      MOV.W  R4, R4
      BNE   L1
```

### 6.5.4 When NMI Is Disabled

When NMI is disabled, the input level to the  $\overline{\text{NMI}}$  pin must be fixed high or low. It is recommended that the NMI interrupt exception handling address be set to the NMI vector address (H'00001C to H'00001F) and that the RTE instruction also be set to the NMI exception handling address.

<Program Example>

```
.ORG      H'00001C
```

```
.DATA.L   NMI
```

```
.
```

```
.
```

```
.
```

```
.
```

```
NMI : RTE
```



## Section 7 ROM (H8S/2194 Group)

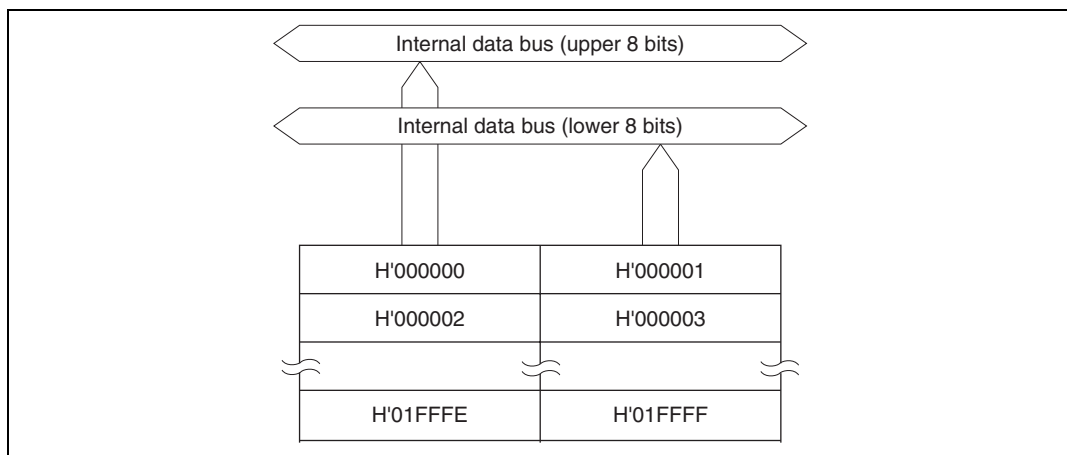
### 7.1 Overview

The H8S/2194 has 128 kbytes of on-chip ROM (flash memory or mask ROM), the H8S/2193 has 112 kbytes, the H8S/2192 has 96 kbytes, and the H8S/2191 has 80 kbytes. The ROM is connected to the CPU by a 16-bit data bus. The CPU accesses both byte and word data in one state, enabling faster instruction fetches and higher processing speed.

The flash memory versions of the H8S/2194 can be erased and programmed on-board as well as with a general-purpose PROM programmer.

#### 7.1.1 Block Diagram

Figure 7.1 shows a block diagram of the ROM.



**Figure 7.1 ROM Block Diagram (H8S/2194)**

## 7.2 Overview of Flash Memory

### 7.2.1 Features

The features of the flash memory are summarized below.

- Four flash memory operating modes
  - Program mode
  - Erase mode
  - Program-verify mode
  - Erase-verify mode
- Programming/erase methods

The flash memory is programmed 32 bytes at a time. Erasing is performed by block erase (in single-block units). When erasing all blocks, the individual blocks must be erased sequentially. Block erasing can be performed as required on 1-kbyte, 8-kbyte, 16-kbyte, 28-kbyte, and 32-kbyte blocks.
- Programming/erase times

The flash memory programming time is 10 ms (typ.) for simultaneous 32-byte programming, equivalent to 300  $\mu$ s (typ.) per byte, and the erase time is 100 ms (typ.) per block.
- Reprogramming capability

The flash memory can be reprogrammed up to 100 times.
- On-board programming modes

There are two modes in which flash memory can be programmed/erased/verified on-board:

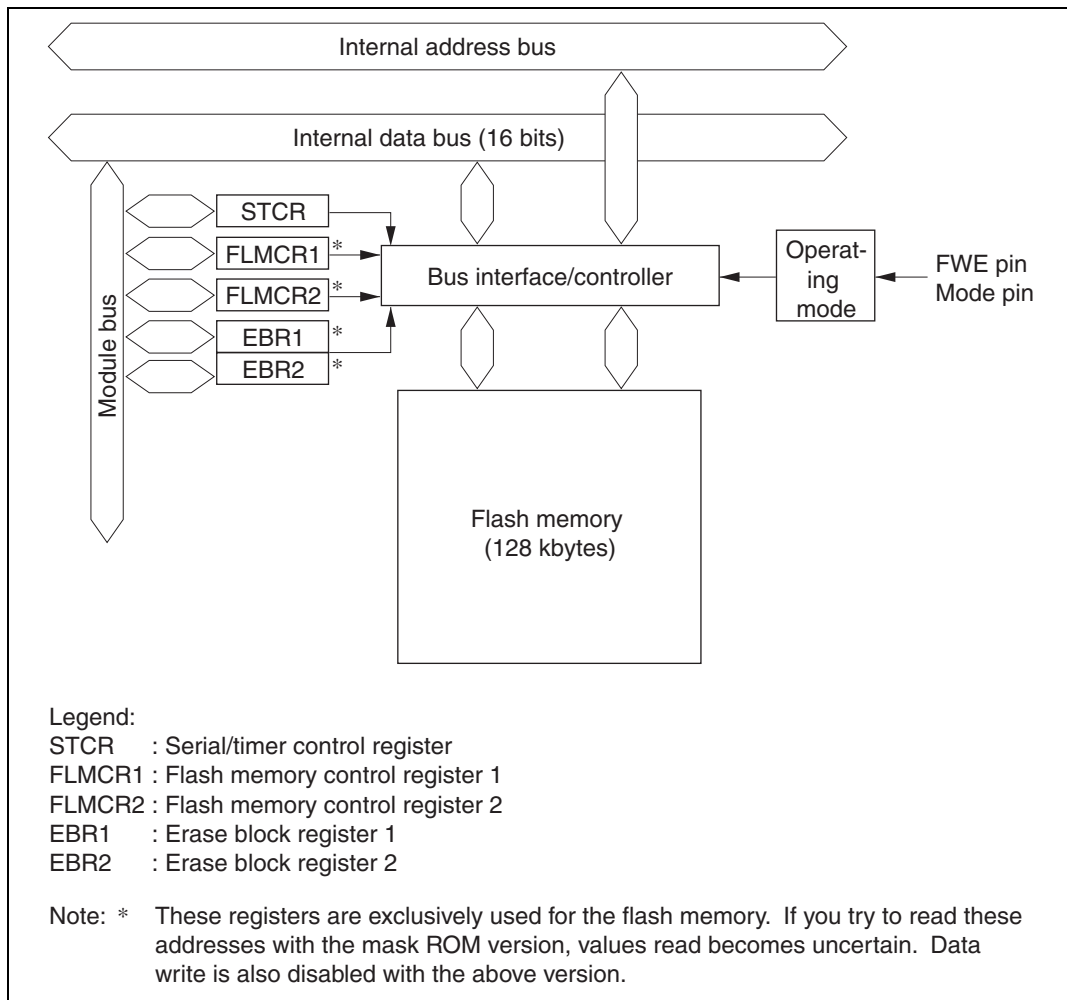
  - Boot mode
  - User program mode
- Automatic bit rate adjustment

If data transfer on boot mode, automatic adjustment is possible at host transfer bit rates and MCU's bit rates.
- Protect modes

There are three protect modes, hardware, software, and error protect, which allow protected status to be designated for flash memory program/erase/verify operations.
- Programmer mode

Flash memory can be programmed/erased in programmer mode, using a PROM programmer, as well as in on-board programming mode.

## 7.2.2 Block Diagram



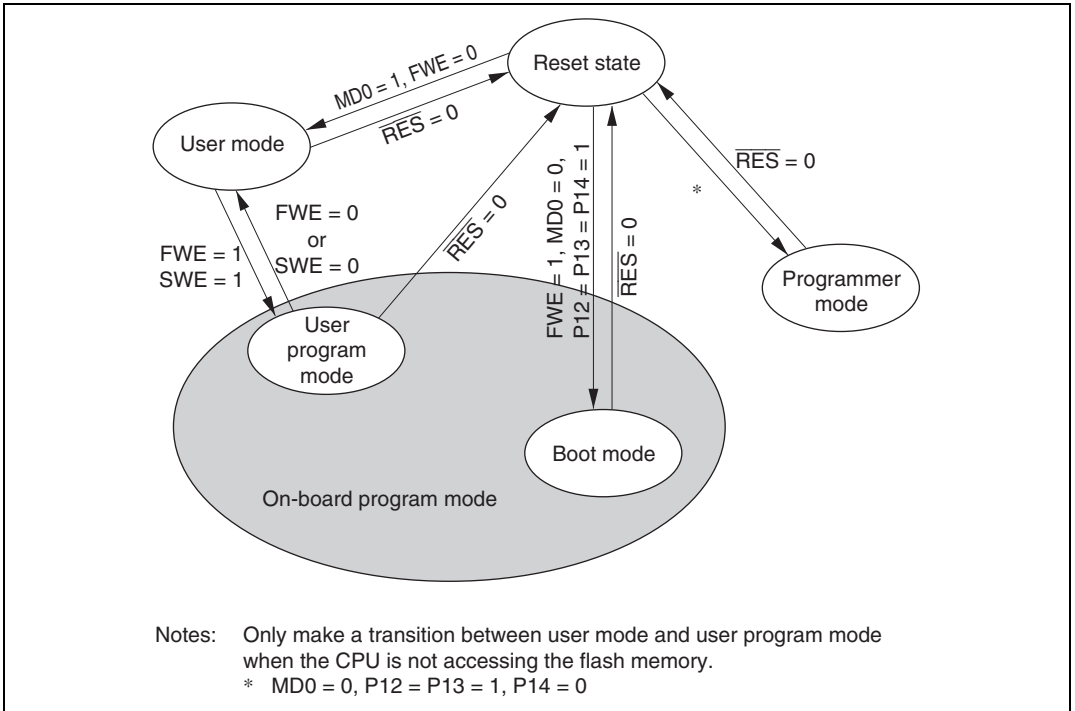
**Figure 7.2 Block Diagram of Flash Memory**

### 7.2.3 Flash Memory Operating Modes

#### (1) Mode Transitions

When each mode pin and the FWE pin are set in the reset state and a reset-start is executed, the MCU enters one of the operating modes shown in figure 7.3. In user mode, flash memory can be read but not programmed or erased.

Flash memory can be programmed and erased in boot mode, user program mode, and programmer mode.



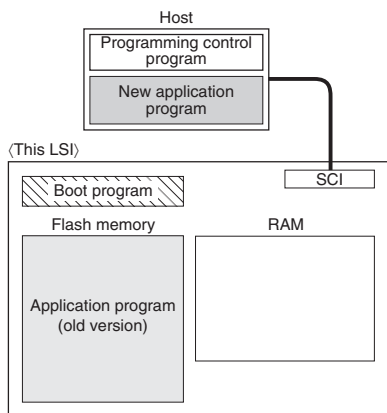
**Figure 7.3 Flash Memory Mode Transitions**

## (2) On-Board Programming Modes

## (a) Boot mode

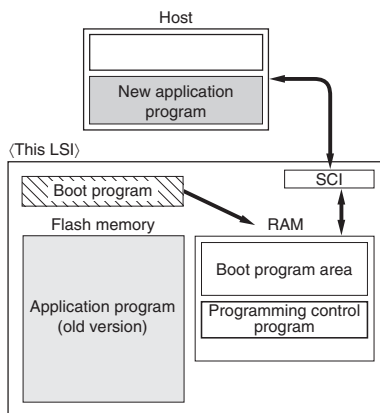
## 1. Initial state

The old program version or data remains written in the flash memory. The user should prepare the programming control program and new application program beforehand in the host.



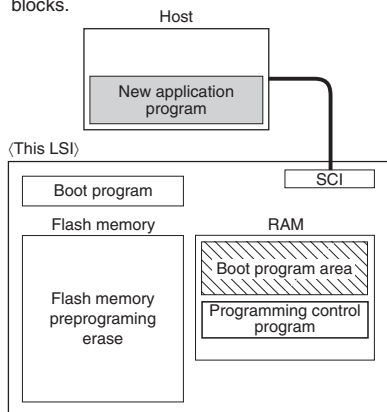
## 2. Programming control program transfer

When boot mode is entered, the boot program in the LSI (originally incorporated in the chip) is started and the programming control program in the host is transferred to RAM via SCI communication. The boot program required for flash memory erasing is automatically transferred to the RAM boot program area.



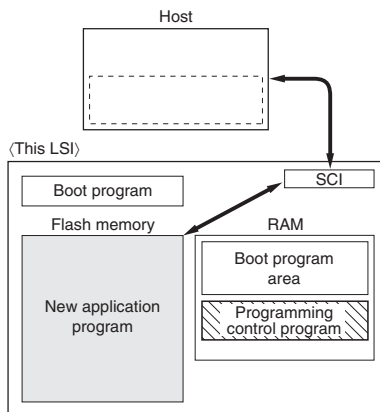
## 3. Flash memory initialization


The erase program in the boot program area (in RAM) is executed, and the flash memory is initialized (to H'FF). In boot mode, entire flash memory erasure is performed, without regard to blocks.



## 4. Writing new application program

The programming control program transferred from the host to RAM is executed, and the new application program in the host is written into the flash memory.



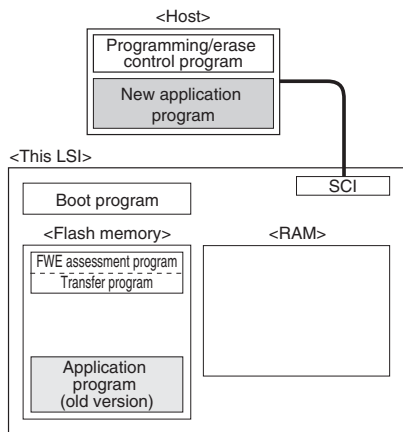
 Program execution state

**Figure 7.4 Boot Mode**

## (b) User program mode

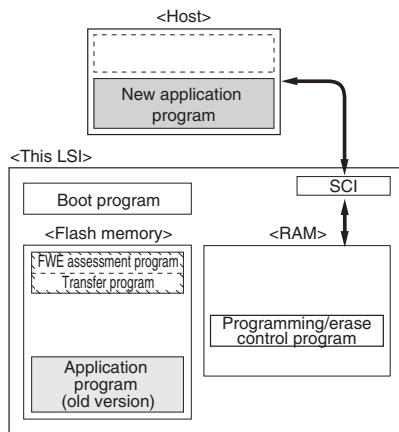
## 1. Initial state

(1) The FWE assessment program that confirms that the FWE pin has been driven high, and (2) the program that will transfer the programming/erase control program from the flash memory to on-chip RAM should be written into the flash memory by the user beforehand. (3) The programming/erase control program should be prepared in the host or in the flash memory.



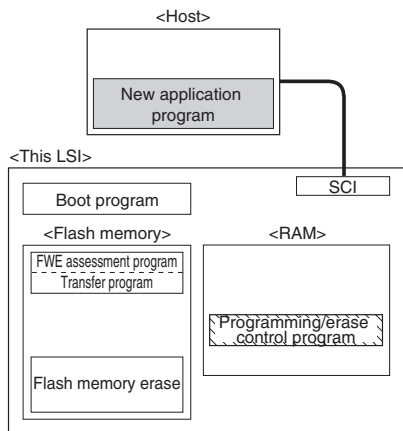
## 2. Programming/erase control program transfer

When user program mode is entered, user software confirms this fact, executes the transfer program in the flash memory, and transfers the programming/erase control program to RAM.



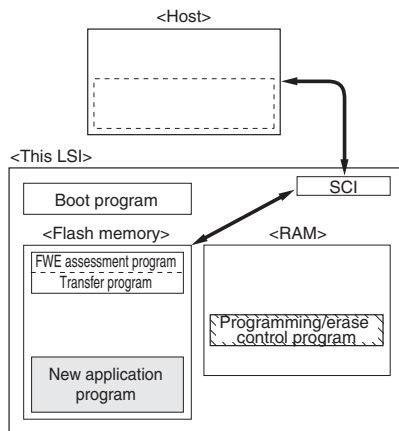
## 3. Flash memory initialization

The programming/erase control program in RAM is executed, and the flash memory is initialized (to H'FF). Erasing can be performed in block units, but not in byte units.



## 4. Writing new application program

Next, the new application program in the host is written into the erased flash memory blocks. Do not write to unerased blocks.




 Program execution state

Figure 7.5 User Program Mode (Example)

## (3) Differences between Boot Mode and User Program Mode

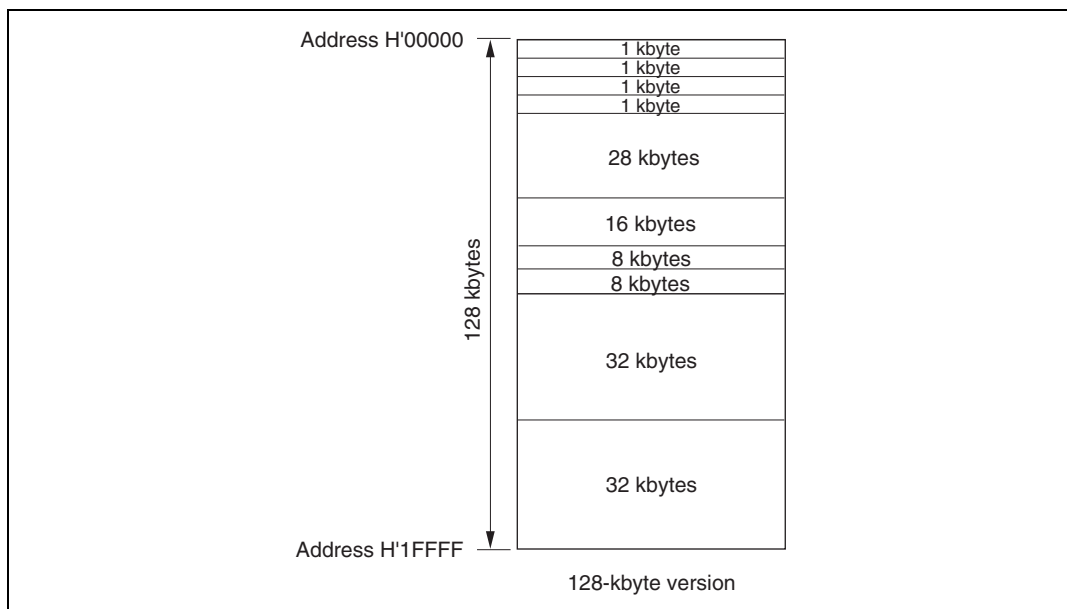
**Table 7.1 Differences between Boot Mode and User Program Mode**

	<b>Boot Mode</b>	<b>User Program Mode</b>
Entire memory erase	Yes	Yes
Block erase	No	Yes
Programming control program*	Program/program-verify	Erase/erase-verify Program/program-verify

Note: \* To be provided by the user, in accordance with the recommended algorithm.

## (4) Block Configuration

The flash memory is divided into two 32-kbyte blocks, two 8-kbyte blocks, one 16-kbyte block, one 28-kbyte block, and four 1-kbyte blocks.

**Figure 7.6 Flash Memory Block Configuration**

## 7.2.4 Pin Configuration

The flash memory is controlled by means of the pins shown in table 7.2.

**Table 7.2 Flash Memory Pins**

Pin Name	Abbreviation	I/O	Function
Reset	$\overline{\text{RES}}$	Input	Reset
Flash write enable	FWE	Input	Flash program/erase protection by hardware
Mode 0	MD0	Input	Sets this LSI operating mode
Port 12	P12	Input	Sets this LSI operating mode when MD0 = 0
Port 13	P13	Input	Sets this LSI operating mode when MD0 = 0
Port 14	P14	Input	Sets this LSI operating mode when MD0 = 0
Transmit data	SO1	Output	Serial transmit data output
Receive data	SI1	Input	Serial receive data input

## 7.2.5 Register Configuration

The registers used to control the on-chip flash memory when enabled are shown in table 7.3. In order to access these registers, the FLSHE bit in STCR must be set to 1.

**Table 7.3 Flash Memory Registers**

Register Name	Abbreviation	R/W	Initial Value	Address <sup>*5</sup>
Flash memory control register 1	FLMCR1 <sup>*4</sup>	R/W <sup>*1</sup>	H'00 <sup>*2</sup>	H'FFF8
Flash memory control register 2	FLMCR2 <sup>*4</sup>	R/W <sup>*1</sup>	H'00 <sup>*3</sup>	H'FFF9
Erase block register 1	EBR1 <sup>*4</sup>	R/W <sup>*1</sup>	H'00 <sup>*3</sup>	H'FFFA
Erase block register 2	EBR2 <sup>*4</sup>	R/W <sup>*1</sup>	H'00 <sup>*3</sup>	H'FFFB
Serial/timer control register	STCR	R/W	H'00	H'FFEE

- Notes:
1. When the FWE bit in FLMCR1 is not set at 1, writes are disabled.
  2. When a high level is input to the FWE pin, the initial value is H'80.
  3. When a low level is input to the FWE pin, or if a high level is input and the SWE bit in FLMCR1 is not set, these registers are initialized to H'00.
  4. FLMCR1, FLMCR2, EBR1, and EBR2 are 8-bit registers. Only byte accesses are valid for these registers, the access requiring 2 states.
  5. Lower 16 bits of the address.



## 7.3 Flash Memory Register Descriptions

### 7.3.1 Flash Memory Control Register 1 (FLMCR1)

Bit:	7	6	5	4	3	2	1	0
	FWE	SWE	—	—	EV	PV	E	P
Initial value:	—*	0	0	0	0	0	0	0
R/W:	R	R/W	—	—	R/W	R/W	R/W	R/W

Note: \* Determined by the state of the FWE pin.

FLMCR1 is an 8-bit register used for flash memory operating mode control. Program-verify mode or erase-verify mode is entered by setting SWE to 1 when FWE = 1. Program mode is entered by setting SWE to 1 when FWE = 1, then setting the PSU bit in FLMCR2, and finally setting the P bit. Erase mode is entered by setting SWE to 1 when FWE = 1, then setting the ESU bit in FLMCR2, and finally setting the E bit. FLMCR1 is initialized by a reset, in power-down state (excluding the medium-speed mode, module stop mode, and sleep mode), or when a low level is input to the FWE pin. Its initial value is H'80 when a high level is input to the FWE pin, and H'00 when a low level is input. When on-chip flash memory is disabled, a read will return H'00, and writes are invalid.

Writes to the SWE bit in FLMCR1 are enabled only when FWE = 1; writes to the EV and PV bits only when FEW = 1 and SWE = 1; writes to the E bit only when FWE = 1, SWE = 1, and ESU = 1; and writes to the P bit only when FWE = 1, SWE = 1, and PSU = 1.

**Bit 7—Flash Write Enable (FWE):** Sets hardware protection against flash memory programming/erasing.

#### Bit 7

FWE	Description
0	When a low level is input to the FWE pin (hardware-protected state)
1	When a high level is input to the FWE pin

**Bit 6—Software Write Enable (SWE):** Enables or disables flash memory programming. SWE should be set before setting bits ESU, PSU, EV, PV, E, P, and EB9 to EB0, and should not be cleared at the same time as these bits.

**Bit 6**

SWE	Description
0	Writes are disabled (Initial value)
1	Writes are enabled [Setting condition] Setting is available when FWE = 1 is selected

**Bits 5 and 4—Reserved:** These bits cannot be modified and are always read as 0.

**Bit 3—Erase-Verify (EV):** Selects erase-verify mode transition or clearing. Do not set the SWE, ESU, PSU, PV, E, or P bit at the same time.

**Bit 3**

EV	Description
0	Erase-verify mode cleared (Initial value)
1	Transition to erase-verify mode [Setting condition] Setting is available when FWE = 1 and SWE = 1 are selected

**Bit 2—Program-Verify (PV):** Selects program-verify mode transition or clearing. Do not set the SWE, ESU, PSU, EV, E, or P bit at the same time.

**Bit 2**

PV	Description
0	Program-verify mode cleared (Initial value)
1	Transition to program-verify mode [Setting condition] Setting is available when FWE = 1 and SWE = 1 are selected

**Bit 1—Erase (E):** Selects erase mode transition or clearing. Do not set the SWE, ESU, PSU, EV, PV, or P bit at the same time.

**Bit 1**

<b>E</b>	<b>Description</b>
0	Erase mode cleared (Initial value)
1	Transition to erase mode [Setting condition] Setting is available when FWE = 1, SWE = 1, and ESU = 1 are selected

**Bit 0—Program (P):** Selects program mode transition or clearing. Do not set the SWE, PSU, ESU, EV, PV, or E bit at the same time.

**Bit 0**

<b>P</b>	<b>Description</b>
0	Program mode cleared (Initial value)
1	Transition to program mode [Setting condition] Setting is available when FWE = 1, SWE = 1, and PSU = 1 are selected

### 7.3.2 Flash Memory Control Register 2 (FLMCR2)

Bit :	7	6	5	4	3	2	1	0
	FLER	—	—	—	—	—	ESU	PSU
Initial value :	0	0	0	0	0	0	0	0
R/W :	R	—	—	—	—	—	R/W	R/W

FLMCR2 is an 8-bit register that monitors the presence or absence of flash memory program/erase protection (error protection) and performs setup for flash memory program/erase mode. FLMCR2 is initialized to H'00 by a reset. The ESU and PSU bits are cleared to 0 in power-down state (excluding the medium-speed mode, module stop mode, and sleep mode), hardware protect mode, or software protect mode.

**Bit 7—Flash Memory Error (FLER):** Indicates that an error has occurred during an operation on flash memory (programming or erasing). When FLER is set to 1, flash memory goes to the error-protection state.

#### Bit 7

FLER	Description
0	Flash memory is operating normally Flash memory program/erase protection (error protection) is disabled [Clearing condition] Reset or hardware standby mode (Initial value)
1	An error has occurred during flash memory programming/erasing Flash memory program/erase protection (error protection) is enabled [Setting condition] See section 7.6.3, Error Protection

**Bits 6 to 2—Reserved:** These bits cannot be modified and are always read as 0.

**Bit 1—Erase Setup (ESU):** Prepares for a transition to erase mode. Set this bit to 1 before setting the E bit to 1 in FLMCR1. Do not set the SWE, PSU, EV, PV, E, or P bit at the same time.

**Bit 1**

<b>ESU</b>	<b>Description</b>
0	Erase setup cleared (Initial value)
1	Erase setup [Setting condition] When FWE = 1, and SWE = 1

**Bit 0—Program Setup (PSU):** Prepares for a transition to program mode. Set this bit to 1 before setting the P bit to 1 in FLMCR1. Do not set the SWE, ESU, EV, PV, E, or P bit at the same time.

**Bit 0**

<b>PSU</b>	<b>Description</b>
0	Program setup cleared (Initial value)
1	Program setup [Setting condition] When FWE = 1, and SWE = 1

### 7.3.3 Erase Block Registers 1 and 2 (EBR1, EBR2)

Bit :	7	6	5	4	3	2	1	0
EBR1 :	—	—	—	—	—	—	EB9	EB8
Initial value :	0	0	0	0	0	0	0	0
R/W :	—	—	—	—	—	—	R/W	R/W
Bit :	7	6	5	4	3	2	1	0
EBR2 :	EB7	EB6	EB5	EB4	EB3	EB2	EB1	EB0
Initial value :	0	0	0	0	0	0	0	0
R/W :	R/W	R/W	R/W	R/W	R/W	R/W	R/W	R/W

EBR1 and EBR2 are registers that specify the flash memory erase area block by block; bits 1 and 0 in EBR1 (128-kbyte versions only) and bits 7 to 0 in EBR2 are readable/writable bits. EBR1 and EBR2 are each initialized to H'00 by a reset, in power-down state (excluding the medium-speed mode, module stop mode, and sleep mode), when a low level is input to the FWE pin, or when a high level is input to the FWE pin and the SWE bit in FLMCR1 is not set. When a bit in EBR1 or EBR2 is set, the corresponding block can be erased. Other blocks are erase-protected. Set only one bit in EBR1 or EBR2 (more than one bit cannot be set).

The flash memory block configuration is shown in table 7.4.

**Table 7.4 Flash Memory Erase Blocks**

Block (Size)	Address
<b>128-kbyte Versions</b>	
EB0 (1 kbyte)	H'000000 to H'0003FF
EB1 (1 kbyte)	H'000400 to H'0007FF
EB2 (1 kbyte)	H'000800 to H'000BFF
EB3 (1 kbyte)	H'000C00 to H'000FFF
EB4 (28 kbytes)	H'001000 to H'007FFF
EB5 (16 kbytes)	H'008000 to H'00BFFF
EB6 (8 kbytes)	H'00C000 to H'00DFFF
EB7 (8 kbytes)	H'00E000 to H'00FFFF
EB8 (32 kbytes)	H'010000 to H'017FFF
EB9 (32 kbytes)	H'018000 to H'01FFFF

### 7.3.4 Serial/Timer Control Register (STCR)

Bit	:	7	6	5	4	3	2	1	0
		—	IICX	IICRST	—	FLSHE	—	—	—
Initial value	:	0	0	0	0	0	0	0	0
R/W	:	—	R/W	R/W	—	R/W	—	—	—

STCR is an 8-bit readable/writable register that controls register access, the I<sup>2</sup>C bus interface operating mode, and on-chip flash memory (in F-ZTAT versions), and also selects the I<sup>2</sup>C bus interface serial clock frequency. For details on functions not related to on-chip flash memory, see section 25.2.7, Serial/Timer Control Register (STCR), and descriptions of individual modules. If a module controlled by STCR is not used, do not write 1 to the corresponding bit.

STCR is initialized to H'00 by a reset.

**Bits 6 and 5—I<sup>2</sup>C Control (IICX, IICRST):** These bits control the operation of the I<sup>2</sup>C bus interface. For details, see section 25, I<sup>2</sup>C Bus Interface (IIC).

**Bit 3—Flash Memory Control Register Enable (FLSHE):** Setting the FLSHE bit to 1 enables read/write access to the flash memory control registers. If FLSHE is cleared to 0, the flash memory control registers are deselected. In this case, the flash memory control register contents are retained.

#### Bit 3

FLSHE	Description
0	Flash memory control registers deselected (Initial value)
1	Flash memory control registers selected

**Bits 7, 4, and 2 to 0—Reserved**

## 7.4 On-Board Programming Modes

When pins are set to on-board programming mode, program/erase/verify operations can be performed on the on-chip flash memory. There are two on-board programming modes: boot mode and user program mode. The pin settings for transition to each of these modes are shown in table 7.5. For a diagram of the transitions to the various flash memory modes, see figure 7.3.

**Table 7.5 Setting On-Board Programming Modes**

Mode	Pin				
	Mode Name	FWE	MD0	P12	P13
Boot mode	1	0	1 <sup>*2</sup>	1 <sup>*2</sup>	1 <sup>*2</sup>
User program mode	1 <sup>*1</sup>	1	—	—	—

- Notes:
1. In user program mode, the FWE pin should not be constantly set to 1. Set FWE to 1 to make a transition to user program mode before performing a program/erase/verify operation.
  2. Can be used as I/O ports after boot mode is initiated.



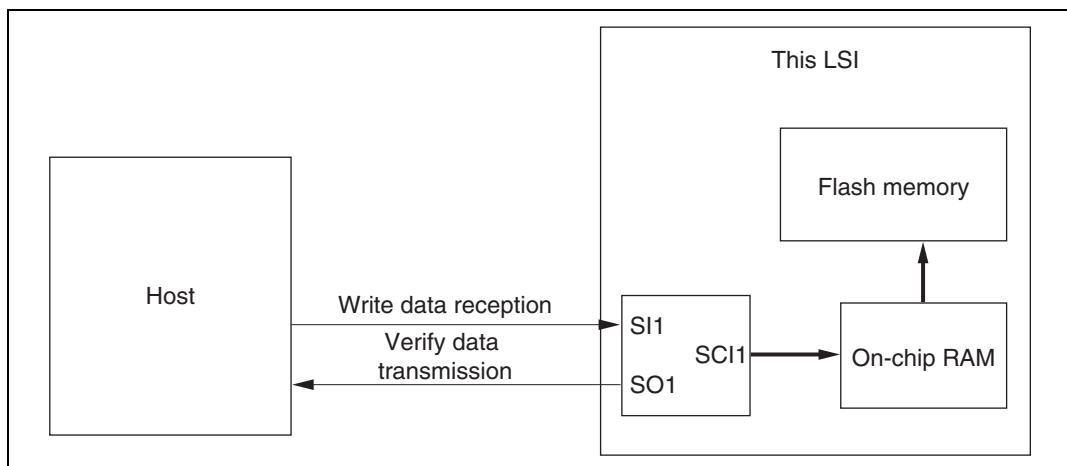
### 7.4.1 Boot Mode

When boot mode is used, the flash memory programming control program must be prepared in the host beforehand. The channel 1 SCI to be used is set to asynchronous mode.

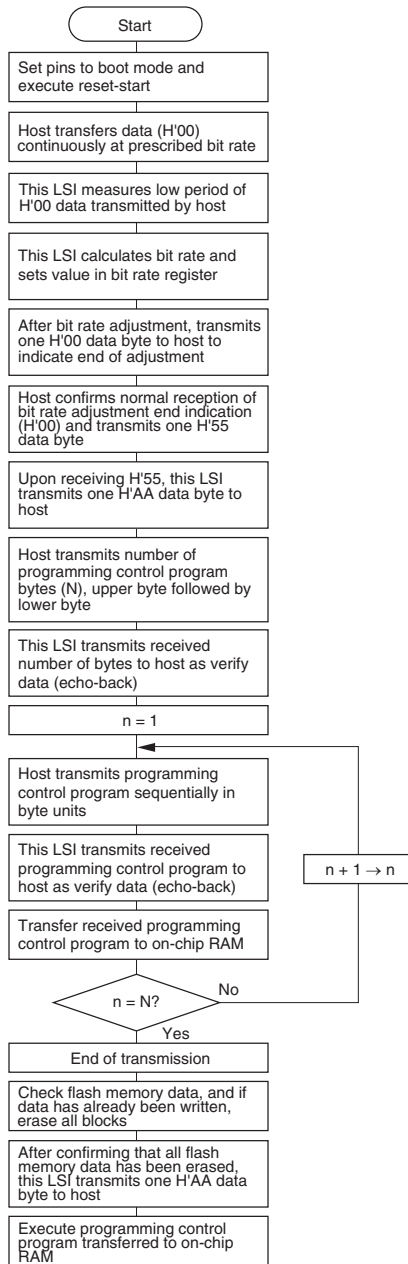
When a reset-start is executed after the MCU's pins have been set to boot mode, the boot program built into the MCU is started and the programming control program prepared in the host is serially transmitted to the MCU via the SCI1. In the MCU, the programming control program received via the SCI1 is written into the programming control program area in on-chip RAM. After the transfer is completed, control branches to the start address of the programming control program area and the programming control program execution state is entered (flash memory programming is performed).

The transferred programming control program must therefore include coding that follows the programming algorithm given later.

The system configuration in boot mode is shown in figure 7.7, and the boot program mode execution procedure in figure 7.8.



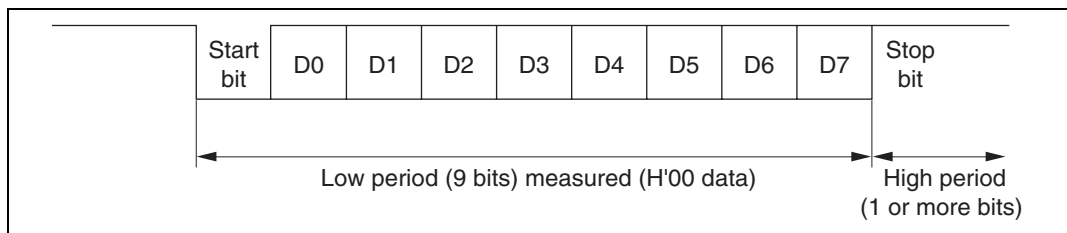
**Figure 7.7 System Configuration in Boot Mode**



Note : If a memory cell does not operate normally and cannot be erased, one H'FF byte is transmitted as an erase error, and the erase operation and subsequent operations are halted.

**Figure 7.8 Boot Mode Execution Procedure**

## (1) Automatic SCI Bit Rate Adjustment

**Figure 7.9 Automatic SCI Bit Rate Adjustment**

When boot mode is initiated, the MCU measures the low period of the asynchronous SCI communication data (H'00) transmitted continuously from the host. The SCI transmit/receive format should be set as follows: 8-bit data, 1 stop bit, no parity. The MCU calculates the bit rate of the transmission from the host from the measured low period, and transmits one H'00 byte to the host to indicate the end of bit rate adjustment. The host should confirm that this adjustment end indication (H'00) has been received normally, and transmit one H'55 byte to the MCU. If reception cannot be performed normally, initiate boot mode again (reset), and repeat the above operations. Depending on the host's transmission bit rate and the MCU's system clock frequency, there will be a discrepancy between the bit rates of the host and the MCU. To ensure correct SCI operation, the host's transfer bit rate should be set to (4800 or 9600) bps.

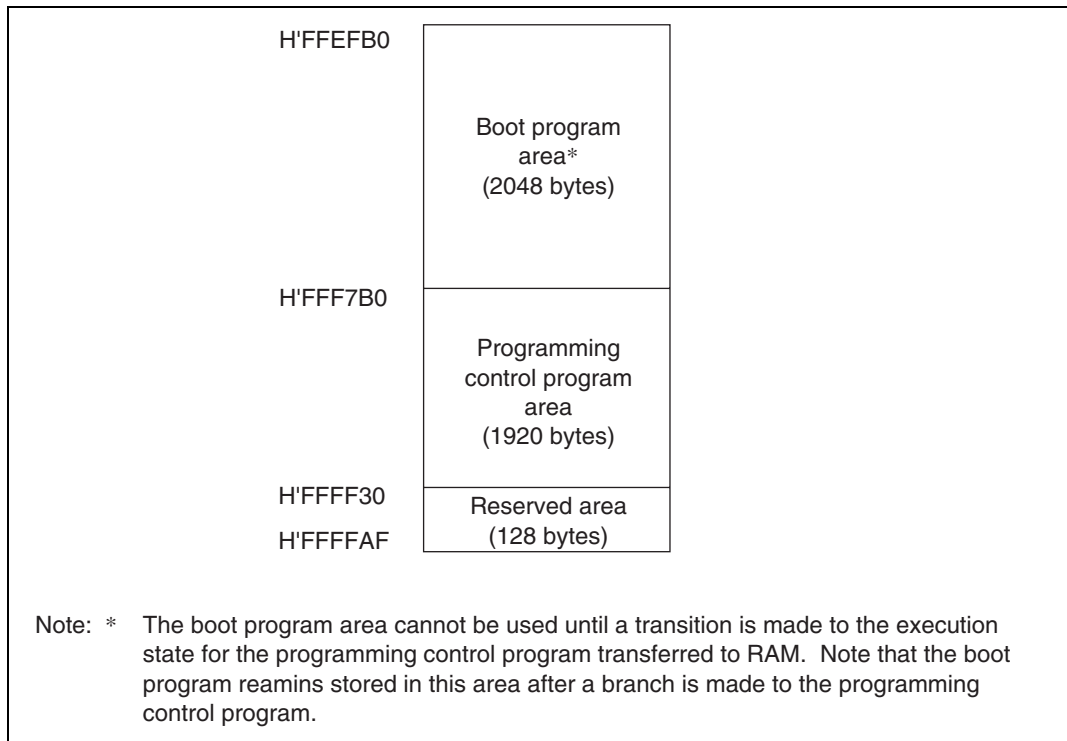
Table 7.6 shows typical host transfer bit rates and system clock frequencies for which automatic adjustment of the MCU's bit rate is possible. The boot program should be executed within this system clock range.

**Table 7.6 System Clock Frequencies for Which Automatic Adjustment of This LSI Bit Rate Is Possible**

<b>Host Bit Rate</b>	<b>System Clock Frequency for Which Automatic Adjustment of This LSI Bit Rate Is Possible</b>
9600 bps	8 MHz to 10 MHz
4800 bps	4 MHz to 10 MHz

## (2) On-Chip RAM Area Divisions in Boot Mode

In boot mode, the 2048-byte area from H'FFEFB0 to H'FFF7AF is reserved for use by the boot program, as shown in figure 7.10. The area to which the programming control program is transferred is H'FFF7B0 to H'FFFF2F (1920 bytes). The boot program area can be used when the programming control program transferred into RAM enters the execution state. A stack area should be set up as required.



**Figure 7.10 RAM Areas in Boot Mode**

## (3) Notes on Use of Boot Mode:

- When reset is released in boot mode, it measures the low period of the input at the SC11's SI1 pin. The reset should end with SI1 pin high. After the reset ends, it takes about 100 states for the chip to get ready to measure the low period of the SI1 pin input.
- In boot mode, if any data has been programmed into the flash memory (if all data is not 1), all flash memory blocks are erased. Boot mode is for use when user program mode is unavailable, such as the first time on-board programming is performed, or if the program activated in user program mode is accidentally erased.
- Interrupts cannot be used while the flash memory is being programmed or erased.
- The SI1 and SO1 pins should be pulled up on the board.

- (e) Before branching to the programming control program (RAM area H'FFF3B0), the chip terminates transmit and receive operations by the on-chip SCI (channel 1) (by clearing the RE and TE bits in SCR to 0), but the adjusted bit rate value remains set in BRR. The transmit data output pin, SO1, goes to the high-level output state ( $P21PCR = 1$ ,  $P21PDR = 1$ ).

The contents of the CPU's internal general registers are undefined at this time, so these registers must be initialized immediately after branching to the programming control program. In particular, since the stack pointer (SP) is used implicitly in subroutine calls, etc., a stack area must be specified for use by the programming control program.

The initial values of other on-chip registers are not changed.

- (f) Boot mode can be entered by making the pin settings shown in table 7.5 and executing a reset-start.

When the chip detects the boot mode setting at reset release<sup>\*1</sup>, it retains that state internally.

Boot mode can be cleared by driving the reset pin low, waiting at least 20 states, then setting the FWE pin and mode pins, and executing reset release<sup>\*1</sup>. Boot mode can also be cleared by a WDT overflow reset.

If the mode pin input levels are changed in boot mode, the boot mode state will be maintained in the microcomputer, and boot mode continued, unless a reset occurs.

However, the FWE pin must not be driven low while the boot program is running or flash memory is being programmed or erased<sup>\*2</sup>.

- Notes: 1. Mode pin and FWE pin input must satisfy the mode programming setup time ( $t_{MDS} = 4$  states) with respect to the reset release timing.
2. For further information on FWE application and disconnection, see section 7.9, Flash Memory Programming and Erasing Precautions.

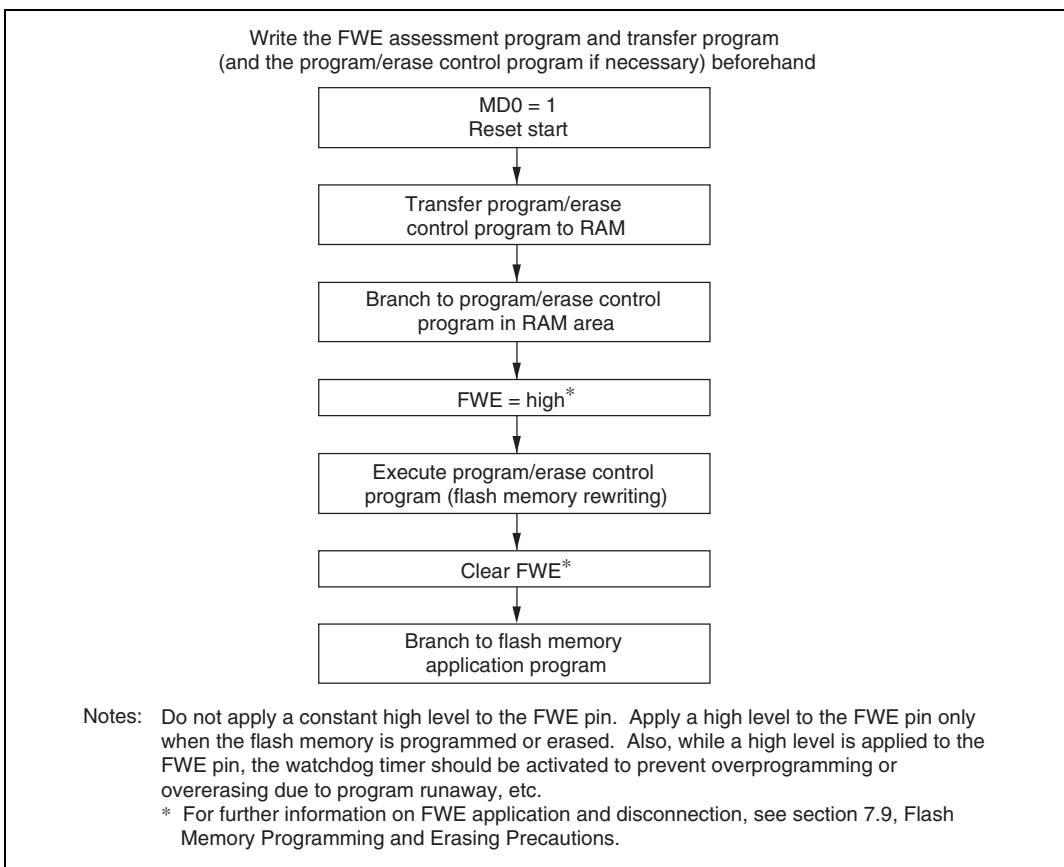
## 7.4.2 User Program Mode

When set to user program mode, the chip can program and erase its flash memory by executing a user program/erase control program. Therefore, on-board reprogramming of the on-chip flash memory can be carried out by providing on-board means of FWE control and supply of programming data, and storing a program/erase control program in part of the program area as necessary.

In this mode, the chip starts up in mode 1 and applies a high level to the FWE pin.

The flash memory itself cannot be read while the SWE bit is set to 1 to perform programming or erasing, so the control program that performs programming and erasing should be run in on-chip RAM or external memory.

Figure 7.11 shows the procedure for executing the program/erase control program when transferred to on-chip RAM.



**Figure 7.11 User Program Mode Execution Procedure**

## 7.5 Programming/Erasing Flash Memory

In the on-board programming modes, flash memory programming and erasing is performed by software, using the CPU. There are four flash memory operating modes: program mode, erase mode, program-verify mode, and erase-verify mode. Transitions to these modes can be made by setting the PSU and ESU bits in FLMCR2, and the P, E, PV, and EV bits in FLMCR1.

The flash memory cannot be read while being programmed or erased. Therefore, the program that controls flash memory programming/erasing (the programming control program) should be located and executed in on-chip RAM or external memory.

- Notes:
1. Operation is not guaranteed if setting/resetting of the SWE, EV, PV, E, and P bits in FLMCR1, and the ESU and PSU bits in FLMCR2, is executed by a program in flash memory.
  2. When programming or erasing, set FWE to 1 (programming/erasing will not be executed if FWE = 0).
  3. Perform programming in the erased state. Do not perform additional programming on previously programmed addresses.

### 7.5.1 Program Mode

Follow the procedure shown in the program/program-verify flowchart in figure 7.12 to write data or programs to flash memory. Performing program operations according to this flowchart will enable data or programs to be written to flash memory without subjecting the device to voltage stress or sacrificing program data reliability. Programming should be carried out 32 bytes at a time.

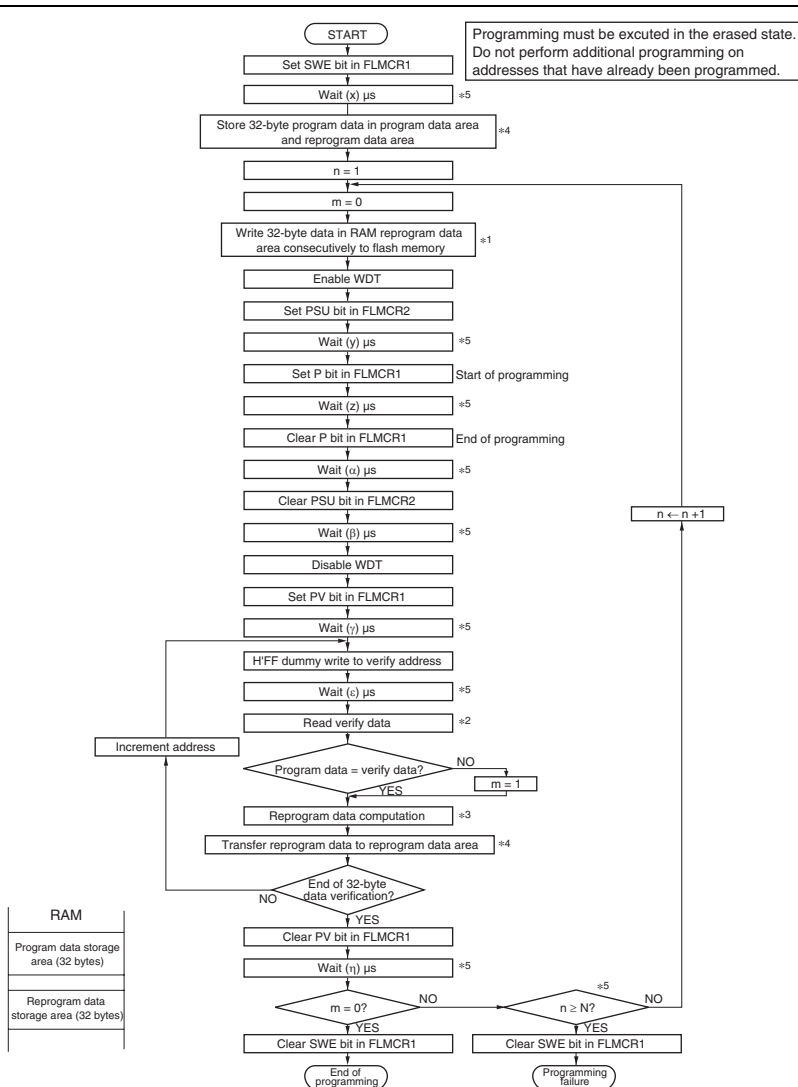
Table 29.12 lists wait time ( $x$ ,  $y$ ,  $z$ ,  $\alpha$ ,  $\beta$ ,  $\gamma$ ,  $\varepsilon$ , and  $\eta$ ) after setting or clearing each bit on the flash memory control registers 1 and 2 (FLMCR1 and FLMCR2) and the maximum write count ( $N$ ). Following the elapse of ( $x$ )  $\mu$ s or more after the SWE bit is set to 1 in flash memory control register 1 (FLMCR1), 32-byte program data is stored in the program data area and reprogram data area, and the 32-byte data in the reprogram data area written consecutively to the write addresses. The lower 8 bits of the first address written to must be H'00, H'20, H'40, H'60, H'80, H'A0, H'C0, or H'E0. Thirty-two consecutive byte data transfers are performed. The program address and program data are latched in the flash memory. A 32-byte data transfer must be performed even if writing fewer than 32 bytes; in this case, H'FF data must be written to the extra addresses. Next, the watchdog timer is set to prevent overprogramming in the event of program runaway, etc. Set more than ( $y + z + \alpha + \beta$ )  $\mu$ s as the WDT overflow period. After this, preparation for program mode (program setup) is carried out by setting the PSU bit in FLMCR2, and after the elapse of ( $y$ )  $\mu$ s or more, the operating mode is switched to program mode by setting the P bit in FLMCR1. The time during which the P bit is set is the flash memory programming time. Make a program setting so that the time for one programming operation is within the range of ( $z$ )  $\mu$ s.

### 7.5.2 Program-Verify Mode

In program-verify mode, the data written in program mode is read to check whether it has been correctly written in the flash memory.

After the elapse of a given programming time, the programming mode is exited (the P bit in FLMCR1 is cleared, then the PSU bit in FLMCR2 is cleared at least ( $\alpha$ )  $\mu$ s later). The watchdog timer is cleared after the elapse of ( $\beta$ )  $\mu$ s or more, and the operating mode is switched to program-verify mode by setting the PV bit in FLMCR1. Before reading in program-verify mode, a dummy write of H'FF data should be made to the addresses to be read. The dummy write should be executed after the elapse of ( $\gamma$ )  $\mu$ s or more. When the flash memory is read in this state (verify data is read in 16-bit units), the data at the latched address is read. Wait at least ( $\epsilon$ )  $\mu$ s after the dummy write before performing this read operation. Next, the originally written data is compared with the verify data, and reprogram data is computed (see figure 7.12) and transferred to the reprogram data area. After 32 bytes of data have been verified, exit program-verify mode, wait for at least ( $\eta$ )  $\mu$ s, then clear the SWE bit in FLMCR1. If reprogramming is necessary, set program mode again, and repeat the program/program-verify sequence as before. However, ensure that the program/program-verify sequence is not repeated more than (N) times on the same bits.





- Notes:
- Data transfer is performed by byte transfer. The lower 8 bits of the first address written to must be H'00, H'20, H'40, H'60, H'80, H'A0, H'C0, or H'E0. A 32-byte data transfer must be performed even if writing fewer than 32 bytes; in this case, HFF data must be written to the extra addresses.
  - Verify data is read in 16-bit (word) units.
  - Even in case of the bit which is already-programmed in the 32-byte programming loop, perform additional programming if the bit fails at the next verify.
  - An area for storing program data (32 bytes) and reprogram data (32 bytes) must be provided in RAM. The contents of the latter are rewritten as programming progresses.
  - The values of x, y, z, α, β, γ, ε, η, and N are listed in section 29.2.7, Flash Memory Characteristics.

Program data	Verify data	Reprogram data	Comments
0	0	1	Do not reprogram bits for which programming has been completed.
0	1	0	Programming incomplete; reprogramming should be performed.
1	0	1	
1	1	1	Still in erased state; no action

**Figure 7.12 Program/Program-Verify Flowchart**

### 7.5.3 Erase Mode

Flash memory erasing should be performed block by block following the procedure shown in the erase/erase-verify flowchart (single-block erase) shown in figure 7.13.

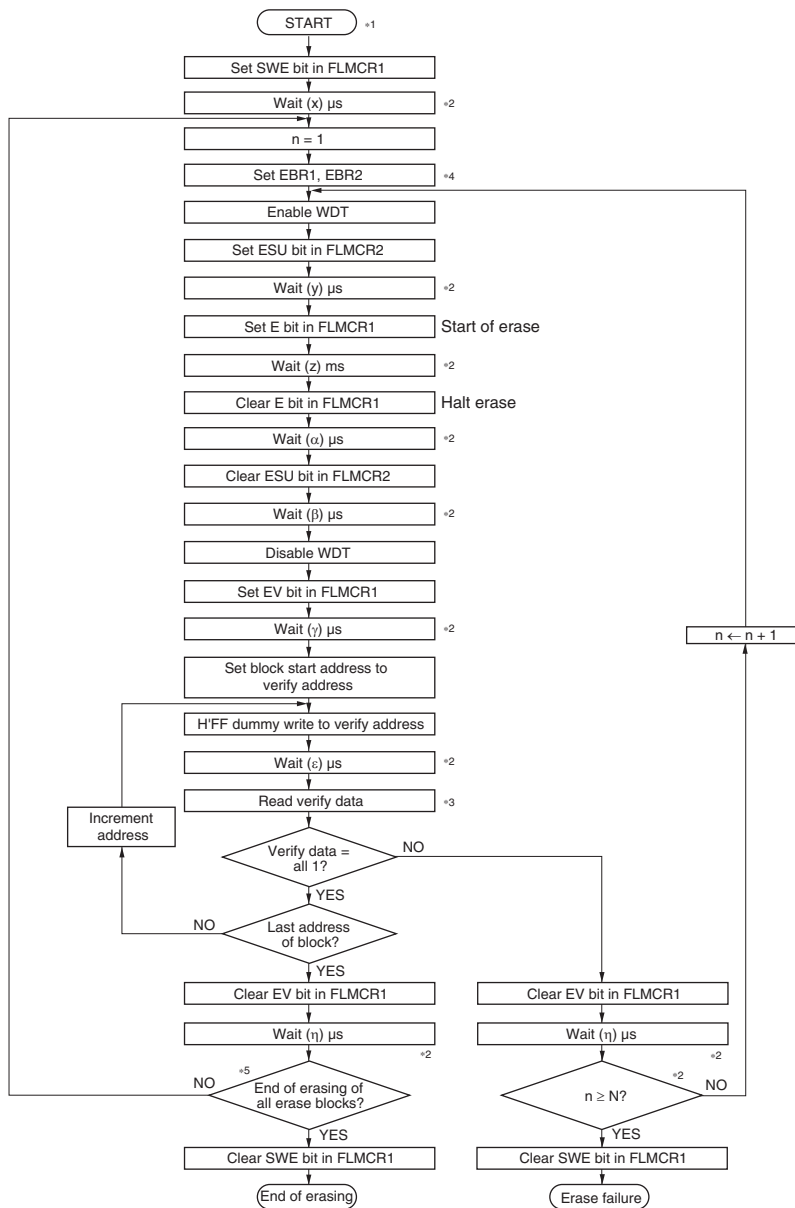
Table 29.12 lists wait time ( $x$ ,  $y$ ,  $z$ ,  $\alpha$ ,  $\beta$ ,  $\gamma$ ,  $\epsilon$ , and  $\eta$ ) after setting or clearing each bit on the flash memory control registers 1 and 2 (FLMCR1 and FLMCR2) and the maximum clearing count ( $N$ ). To perform data or program erasure, make a 1 bit setting for the flash memory area to be erased in erase block register 1 or 2 (EBR1 or EBR2) at least ( $x$ )  $\mu$ s after setting the SWE bit to 1 in flash memory control register 1 (FLMCR1). Next, the watchdog timer is set to prevent overerasing in the event of program runaway, etc. Set more than ( $y + z + \alpha + \beta$ ) ms as the WDT overflow period. After this, preparation for erase mode (erase setup) is carried out by setting the ESU bit in FLMCR2, and after the elapse of ( $y$ )  $\mu$ s or more, the operating mode is switched to erase mode by setting the E bit in FLMCR1. The time during which the E bit is set is the flash memory erase time. Ensure that the erase time does not exceed ( $z$ ) ms.

Note: With flash memory erasing, preprogramming (setting all data in the memory to be erased to 0) is not necessary before starting the erase procedure.

### 7.5.4 Erase-Verify Mode

In erase-verify mode, data is read after memory has been erased to check whether it has been correctly erased.

After the elapse of the erase time, erase mode is exited (the E bit in FLMCR1 is cleared, then the ESU bit in FLMCR2 is cleared at least ( $\alpha$ )  $\mu$ s later), the watchdog timer is cleared after the elapse of ( $\beta$ )  $\mu$ s or more, and the operating mode is switched to erase-verify mode by setting the EV bit in FLMCR1. Before reading in erase-verify mode, a dummy write of H'FF data should be made to the addresses to be read. The dummy write should be executed after the elapse of ( $\gamma$ )  $\mu$ s or more. When the flash memory is read in this state (verify data is read in 16-bit units), the data at the latched address is read. Wait at least ( $\epsilon$ )  $\mu$ s after the dummy write before performing this read operation. If the read data has been erased (all 1), a dummy write is performed to the next address, and erase-verify is performed. If the read data has not been erased, set erase mode again, and repeat the erase/erase-verify sequence in the same way. However, ensure that the erase/erase-verify sequence is not repeated more than ( $N$ ) times. When verification is completed, exit erase-verify mode, and wait for at least ( $\eta$ )  $\mu$ s. If erasure has been completed on all the erase blocks, clear the SWE bit in FLMCR1. If there are any unerased blocks, make a 1 bit setting in EBR1 or EBR2 for the flash memory area to be erased, and repeat the erase/erase-verify sequence in the same way.



- Notes:
1. Preprogramming (setting erase block data to all 0) is not necessary.
  2. The values of x, y, z, α, β, γ, ε, η, and N are listed in section 29.2.7, Flash Memory Characteristics.
  3. Verify data is read in 16-bit (word) units.
  4. Set only one bit in EBR1 or EBR2. More than one bit cannot be set.
  5. Erasing is performed in block units. To erase a number of blocks, the individual blocks must be erased sequentially.

**Figure 7.13 Erase/Erase-Verify Flowchart (Single-Block Erase)**

## 7.6 Flash Memory Protection

There are three kinds of flash memory program/erase protection: hardware protection, software protection, and error protection.

### 7.6.1 Hardware Protection

Hardware protection refers to a state in which programming/erasing of flash memory is forcibly disabled or aborted. Hardware protection is reset by settings in flash memory control registers 1 and 2 (FLMCR1, FLMCR2) and erase block registers 1 and 2 (EBR1, EBR2). In error protection mode, FLMCR1, FLMCR2, EBR1, and EBR2 settings are retained. (See table 7.7.)

**Table 7.7 Hardware Protection**

Item	Description	Functions	
		Program	Erase
FWE pin protection	<ul style="list-style-type: none"> <li>When a low level is input to the FWE pin, FLMCR1, FLMCR2, EBR1, and EBR2 are initialized, and the program/erase-protected state is entered</li> </ul>	Yes	Yes
Reset/standby protection	<ul style="list-style-type: none"> <li>In a reset (including a WDT overflow reset) and in power-down state (excluding the medium-speed mode, module stop mode, and sleep mode), FLMCR1, FLMCR2 (excluding the FLER bit), EBR1, and EBR2 are initialized, and the program/erase-protected state is entered</li> <li>In a reset via the <math>\overline{\text{RES}}</math> pin, the reset state is not entered unless the <math>\overline{\text{RES}}</math> pin is held low until oscillation stabilizes after powering on. In the case of a reset during operation, hold the <math>\overline{\text{RES}}</math> pin low for the <math>\overline{\text{RES}}</math> pulse width specified in the AC characteristics section</li> </ul>	Yes	Yes

## 7.6.2 Software Protection

Software protection can be implemented by setting the SWE bit in FLMCR1 and erase block registers 1 and 2 (EBR1, EBR2). When software protection is in effect, setting the P or E bit in flash memory control register 1 (FLMCR1) does not cause a transition to program mode or erase mode. (See table 7.8.)

**Table 7.8 Software Protection**

Item	Description	Functions	
		Program	Erase
SWE bit protection	<ul style="list-style-type: none"> <li>Clearing the SWE bit to 0 in FLMCR1 sets the program/erase-protected state for all blocks (Execute in on-chip RAM or external memory)</li> </ul>	Yes	Yes
Block specification protection	<ul style="list-style-type: none"> <li>Erase protection can be set for individual blocks by settings in erase block registers 1 and 2 (EBR1, EBR2)</li> <li>Setting EBR1 and EBR2 to H'00 places all blocks in the erase-protected state</li> </ul>	—	Yes

## 7.6.3 Error Protection

In error protection, an error is detected when MCU runaway occurs during flash memory programming/erasing, or operation is not performed in accordance with the program/erase algorithm, and the program/erase operation is aborted. Aborting the program/erase operation prevents damage to the flash memory due to overprogramming or overerasing.

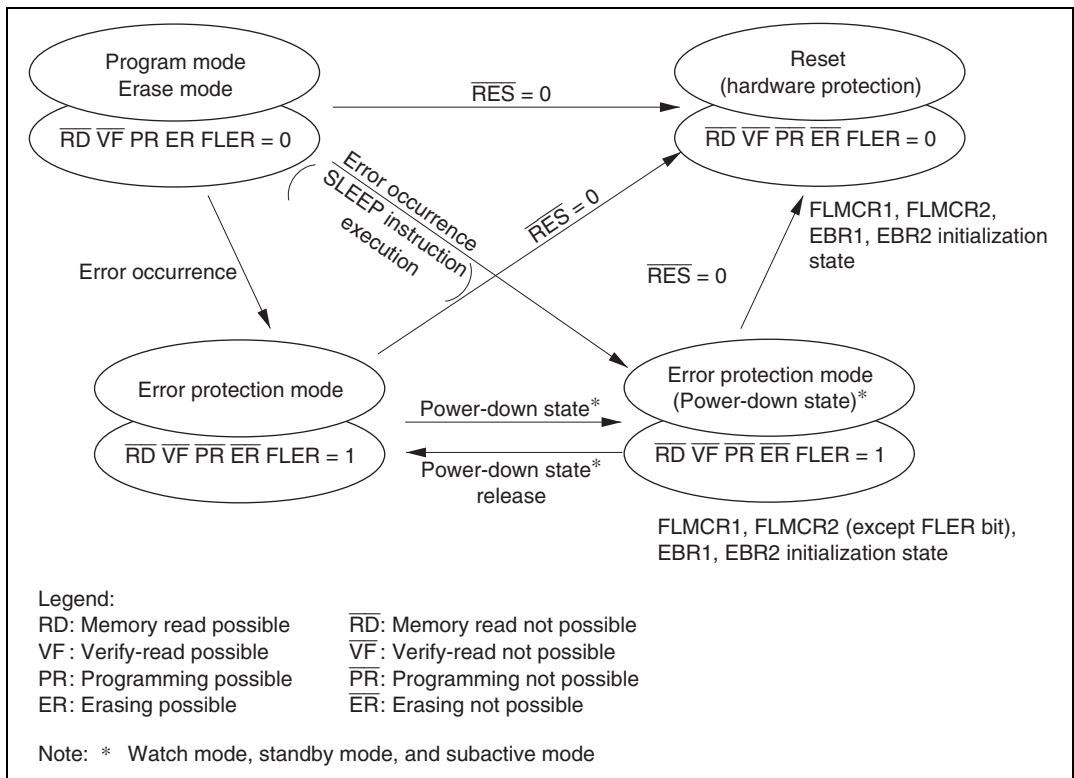
If the MCU malfunctions during flash memory programming/erasing, the FLER bit is set to 1 in FLMCR2 and the error protection state is entered. The FLMCR1, FLMCR2, EBR1, and EBR2 settings are retained, but program mode or erase mode is aborted at the point at which the error occurred. Program mode or erase mode cannot be re-entered by re-setting the P or E bit. However, PV and EV bit setting is enabled, and a transition can be made to verify mode.

FLER bit setting conditions are as follows:

- (1) When flash memory is read during programming/erasing (including a vector read or instruction fetch)
- (2) Immediately after exception handling (excluding a reset) during programming/erasing
- (3) When a SLEEP instruction is executed during programming/erasing

Error protection is released only by a reset and in hardware standby mode.

Figure 7.14 shows the flash memory state transition diagram.



**Figure 7.14 Flash Memory State Transitions**

## 7.7 Interrupt Handling when Programming/Erasing Flash Memory

All interrupts, including NMI input is disabled when flash memory is being programmed or erased (when the P or E bit is set in FLMCR1), and while the boot program is executing in boot mode<sup>\*1</sup>, to give priority to the program or erase operation. There are three reasons for this:

- (1) Interrupt during programming or erasing might cause a violation of the programming or erasing algorithm, with the result that normal operation could not be assured.
- (2) In the interrupt exception handling sequence during programming or erasing, the vector would not be read correctly<sup>\*2</sup>, possibly resulting in MCU runaway.
- (3) If interrupt occurred during boot program execution, it would not be possible to execute the normal boot mode sequence.

For these reasons, in on-board programming mode alone there are conditions for disabling interrupt, as an exception to the general rule. However, this provision does not guarantee normal erasing and programming or MCU operation. All requests, including NMI input, must therefore be disabled inside and outside the MCU during FWE application. Interrupt is also disabled in the error-protection state while the P or E bit remains set in FLMCR1.

- Notes:
1. Interrupt requests must be disabled inside and outside the MCU until data write by the write control program is complete.
  2. The vector may not be read correctly in this case for the following two reasons:
    - If flash memory is read while being programmed or erased (while the P or E bit is set in FLMCR1), correct read data will not be obtained (undetermined values will be returned).
    - If the interrupt entry in the interrupt vector table has not been programmed yet, interrupt exception handling will not be executed correctly.

## 7.8 Flash Memory Programmer Mode

### 7.8.1 Programmer Mode Setting

Programs and data can be written and erased in programmer mode as well as in the on-board programming modes. In programmer mode, the on-chip ROM can be freely programmed using a PROM programmer that supports Renesas Technology microcomputer device type with 128-kbyte on-chip flash memory. Flash memory read mode, auto-program mode, auto-erase mode, and status read mode are supported with these device types. In auto-program mode, auto-erase mode, and status read mode, a status polling procedure is used, and in status read mode, detailed internal signals are output after execution of an auto-program or auto-erase operation.

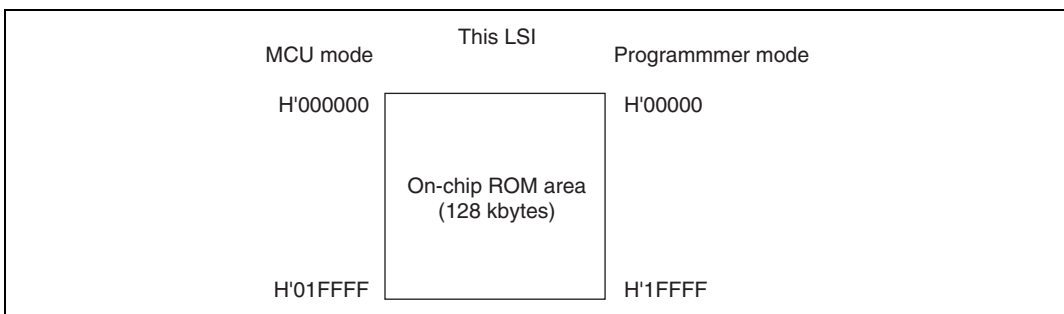
### 7.8.2 Socket Adapters and Memory Map

In programmer mode, a socket adapter is mounted on the writer programmer. The socket adapter product codes are listed in table 7.9.

Figure 7.15 shows the memory map in programmer mode.

**Table 7.9 Socket Adapter Product Codes**

Part No.	Package	Socket Adapter Product Code
HD64F2194	112-pin QFP	ME2194ESHF1H



**Figure 7.15 Memory Map in Programmer Mode**



### 7.8.3 Programmer Mode Operation

Table 7.10 shows how the different operating modes are set when using programmer mode, and table 7.11 lists the commands used in programmer mode. Details of each mode are given below.

#### (1) Memory Read Mode

Memory read mode supports byte reads.

#### (2) Auto-Program Mode

Auto-program mode supports programming of 128 bytes at a time. Status polling is used to confirm the end of auto-programming.

#### (3) Auto-Erase Mode

Auto-erase mode supports automatic erasing of the entire flash memory. Status polling is used to confirm the end of auto-erasing.

#### (4) Status Read Mode

Status polling is used for auto-programming and auto-erasing, and normal termination can be confirmed by reading the FO6 signal. In status read mode, error information is output if an error occurs.

**Table 7.10 Settings for Each Operating Mode in Programmer Mode**

Mode	Pin Names					
	FWE	$\overline{CE}$	$\overline{OE}$	$\overline{WE}$	FO0 to FO7	FA0 to FA17
Read	H or L	L	L	H	Data output	Ain
Output disable	H or L	L	H	H	Hi-Z	X
Command write	H or L <sup>*3</sup>	L	H	L	Data input	Ain <sup>*2</sup>
Chip disable <sup>*1</sup>	H or L	L	X	X	Hi-Z	X

Notes: 1. Chip disable is not a standby state; internally, it is an operation state.

2. Ain indicates that there is also address input in auto-program mode.

3. For command writes when making a transition to auto-program or auto-erase mode, input a high level to the FWE pin.

**Table 7.11 Programmer Mode Commands**

Command Name	Number of Cycles	1st Cycle			2nd Cycle		
		Mode	Address	Data	Mode	Address	Data
Memory read mode	1 + n	write	X	H'00	read	RA	Dout
Auto-program mode	129	write	X	H'40	write	WA	Din
Auto-erase mode	2	write	X	H'20	write	X	H'20
Status read mode	2	write	X	H'71	write	X	H'71

Notes: 1. In auto-program mode, 129 cycles are required for command writing by a simultaneous 128-byte write.

2. In memory read mode, the number of cycles depends on the number of address write cycles (n).

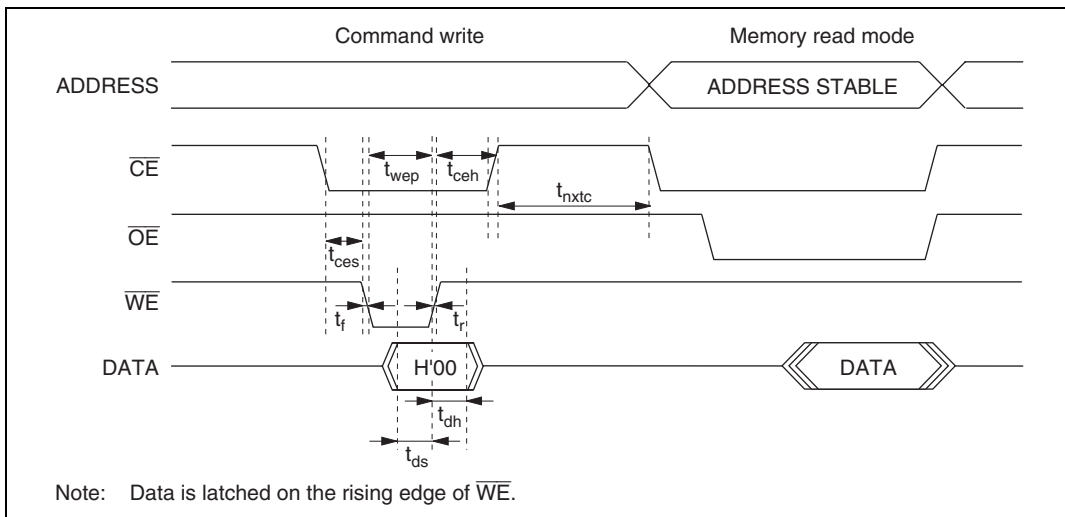
### 7.8.4 Memory Read Mode

- (1) After the end of an auto-program, auto-erase, or status read operation, the command wait state is entered. To read memory contents, a transition must be made to memory read mode by means of a command write before the read is executed.
- (2) Command writes can be performed in memory read mode, just as in the command wait state.
- (3) Once memory read mode has been entered, consecutive reads can be performed.
- (4) After power-on, memory read mode is entered.

**Table 7.12 AC Characteristics in Memory Read Mode (1)**

(Conditions:  $V_{cc} = 5.0 \text{ V} \pm 10\%$ ,  $V_{ss} = 0 \text{ V}$ ,  $T_a = 25^\circ\text{C} \pm 5^\circ\text{C}$ )

Item	Symbol	Min	Max	Unit
Command write cycle	$t_{nxtc}$	20	—	$\mu\text{s}$
$\overline{\text{CE}}$ hold time	$t_{ceh}$	0	—	ns
$\overline{\text{CE}}$ setup time	$t_{ces}$	0	—	ns
Data hold time	$t_{dh}$	50	—	ns
Data setup time	$t_{ds}$	50	—	ns
Write pulse width	$t_{wep}$	70	—	ns
$\overline{\text{WE}}$ rise time	$t_r$	—	30	ns
$\overline{\text{WE}}$ fall time	$t_f$	—	30	ns

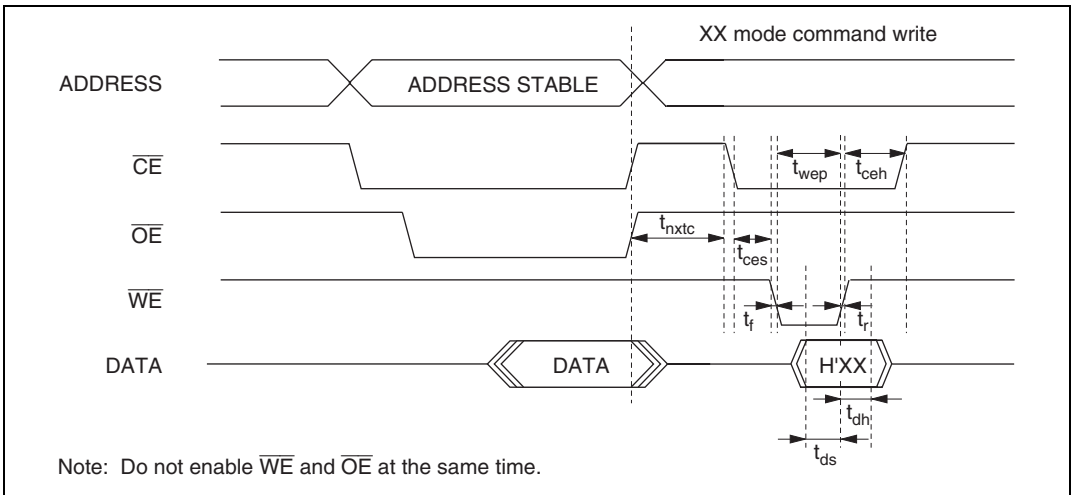


**Figure 7.16 Memory Read Mode Timing Waveforms after Command Write**

**Table 7.13 AC Characteristics when Entering Another Mode from Memory Read Mode**

(Conditions:  $V_{cc} = 5.0 \text{ V} \pm 10\%$ ,  $V_{ss} = 0 \text{ V}$ ,  $T_a = 25^\circ\text{C} \pm 5^\circ\text{C}$ )

Item	Symbol	Min	Max	Unit
Command write cycle	$t_{nxtc}$	20	—	$\mu\text{s}$
$\overline{CE}$ hold time	$t_{ceh}$	0	—	ns
$\overline{CE}$ setup time	$t_{ces}$	0	—	ns
Data hold time	$t_{dh}$	50	—	ns
Data setup time	$t_{ds}$	50	—	ns
Write pulse width	$t_{wep}$	70	—	ns
$\overline{WE}$ rise time	$t_r$	—	30	ns
$\overline{WE}$ fall time	$t_f$	—	30	ns

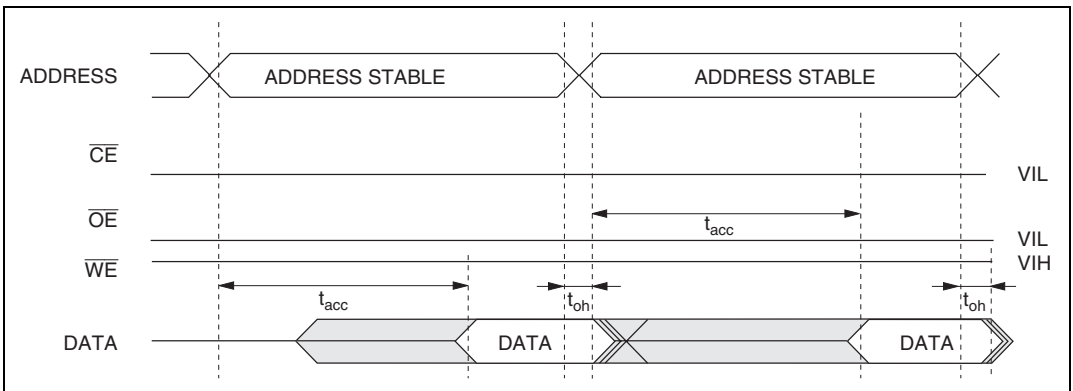


**Figure 7.17 Timing Waveforms when Entering Another Mode from Memory Read Mode**

**Table 7.14 AC Characteristics in Memory Read Mode (2)**

(Conditions:  $V_{CC} = 5.0\text{ V} \pm 10\%$ ,  $V_{SS} = 0\text{ V}$ ,  $T_a = 25^\circ\text{C} \pm 5^\circ\text{C}$ )

Item	Symbol	Min	Max	Unit
Access time	$t_{acc}$	—	20	$\mu\text{s}$
$\overline{CE}$ output delay time	$t_{ce}$	—	150	ns
$\overline{OE}$ output delay time	$t_{oe}$	—	150	ns
Output disable delay time	$t_{df}$	—	100	ns
Data output hold time	$t_{oh}$	5	—	ns



**Figure 7.18 Timing Waveforms for  $\overline{CE}/\overline{OE}$  Enable State Read**

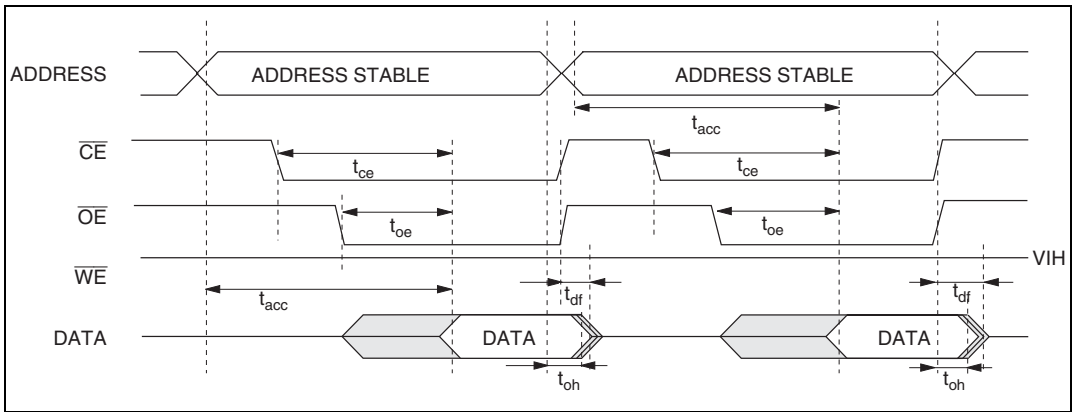


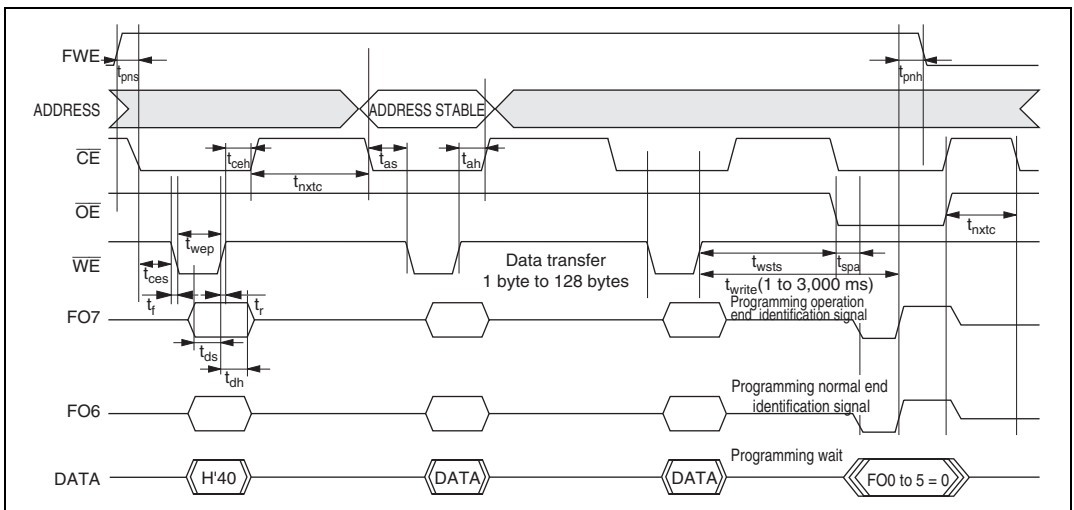
Figure 7.19 Timing Waveforms for  $\overline{CE}/\overline{OE}$  Clocked Read

### 7.8.5 Auto-Program Mode

- In auto-program mode, 128 bytes are programmed simultaneously. This should be carried out by executing 128 consecutive byte transfers.
- A 128-byte data transfer is necessary even when programming fewer than 128 bytes. In this case, H'FF data must be written to the extra addresses.
- The lower 8 bits of the transfer address must be H'00 or H'80. If a value other than an effective address is input, processing will switch to a memory write operation but a write error will be flagged.
- Memory address transfer is performed in the second cycle (figure 7.20). Do not perform transfer after the second cycle.
- Do not perform a command write during a programming operation.
- Perform one auto-programming operation for a 128-byte block for each address. Characteristics are not guaranteed for two or more programming operations.
- Confirm normal end of auto-programming by checking FO6. Alternatively, status read mode can also be used for this purpose (FO7 status polling uses the auto-program operation end identification pin).
- The status polling FO6 and FO7 pin information is retained until the next command write. Until the next command write is performed, reading is possible by enabling  $\overline{CE}$  and  $\overline{OE}$ .

**Table 7.15 AC Characteristics in Auto-Program**(Conditions:  $V_{CC} = 5.0\text{ V} \pm 10\%$ ,  $V_{SS} = 0\text{ V}$ ,  $T_a = 25^\circ\text{C} \pm 5^\circ\text{C}$ )

Item	Symbol	Min	Max	Unit
Command write cycle	$t_{nxtc}$	20	—	$\mu\text{s}$
$\overline{\text{CE}}$ hold time	$t_{ceh}$	0	—	ns
$\overline{\text{CE}}$ setup time	$t_{ces}$	0	—	ns
Data hold time	$t_{dh}$	50	—	ns
Data setup time	$t_{ds}$	50	—	ns
Write pulse width	$t_{wep}$	70	—	ns
Status polling start time	$t_{wsts}$	1	—	ms
Status polling access time	$t_{spa}$	—	150	ns
Address setup time	$t_{as}$	0	—	ns
Address hold time	$t_{ah}$	60	—	ns
Memory write time	$t_{write}$	1	3000	ms
$\overline{\text{WE}}$ rise time	$t_r$	—	30	ns
$\overline{\text{WE}}$ fall time	$t_f$	—	30	ns
Write setup time	$t_{pns}$	100	—	ns
Write end setup time	$t_{pnh}$	100	—	ns

**Figure 7.20 Auto-Program Mode Timing Waveforms**

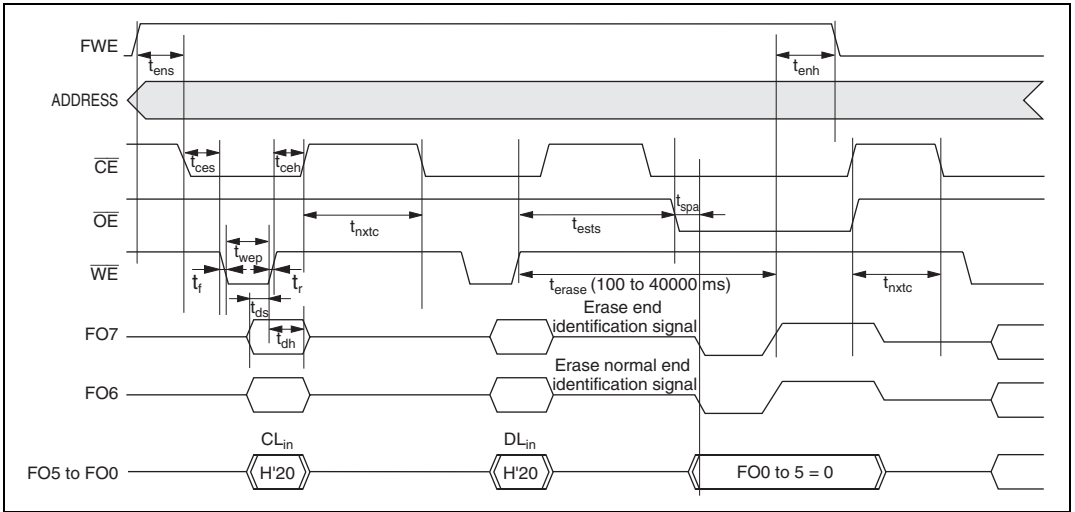
### 7.8.6 Auto-Erase Mode

- (a) Auto-erase mode supports only entire memory erasing.
- (b) Do not perform a command write during auto-erasing.
- (c) Confirm normal end of auto-erasing by checking FO6. Alternatively, status read mode can also be used for this purpose (FO7 status polling uses the auto-erase operation end identification pin).
- (d) The status polling FO6 and FO7 pin information is retained until the next command write. Until the next command write is performed, reading is possible by enabling  $\overline{\text{CE}}$  and  $\overline{\text{OE}}$ .

**Table 7.16 AC Characteristics in Auto-Erase Mode**

(Conditions:  $V_{\text{CC}} = 5.0 \text{ V} \pm 10\%$ ,  $V_{\text{SS}} = 0 \text{ V}$ ,  $T_a = 25^\circ\text{C} \pm 5^\circ\text{C}$ )

Item	Symbol	Min	Max	Unit
Command write cycle	$t_{\text{nxtc}}$	20	—	$\mu\text{s}$
$\overline{\text{CE}}$ hold time	$t_{\text{ceh}}$	0	—	ns
$\overline{\text{CE}}$ setup time	$t_{\text{ces}}$	0	—	ns
Data hold time	$t_{\text{dh}}$	50	—	ns
Data setup time	$t_{\text{ds}}$	50	—	ns
Write pulse width	$t_{\text{wep}}$	70	—	ns
Status polling start time	$t_{\text{ests}}$	1	—	ms
Status polling access time	$t_{\text{spa}}$	—	150	ns
Memory erase time	$t_{\text{erase}}$	100	40000	ms
$\overline{\text{WE}}$ rise time	$t_{\text{r}}$	—	30	ns
$\overline{\text{WE}}$ fall time	$t_{\text{f}}$	—	30	ns
Erase setup time	$t_{\text{ens}}$	100	—	ns
Erase end setup time	$t_{\text{enh}}$	100	—	ns



**Figure 7.21 Auto-Erase Mode Timing Waveforms**

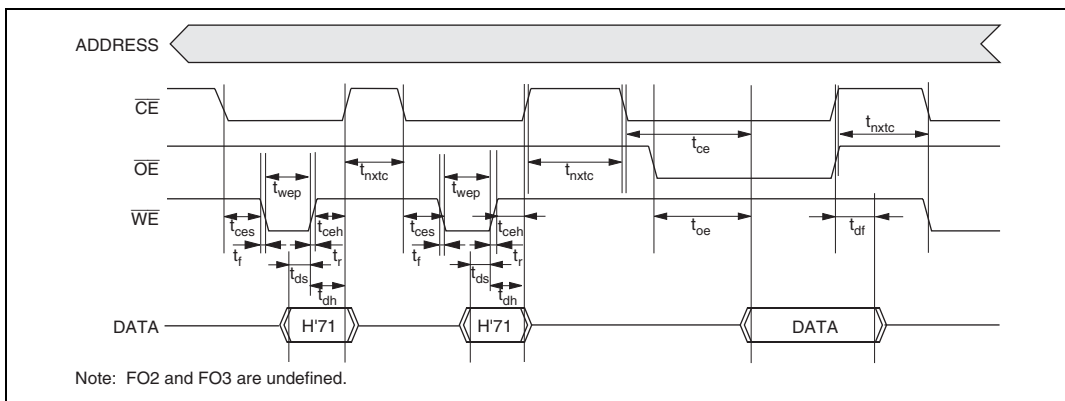
### 7.8.7 Status Read Mode

- (1) Status read mode is used to identify what type of abnormal end has occurred. Use this mode when an abnormal end occurs in auto-program mode or auto-erase mode.
- (2) The return code is retained until a command write for other than status read mode is performed.



**Table 7.17 AC Characteristics in Status Read Mode**(Conditions:  $V_{CC} = 5.0\text{ V} \pm 10\%$ ,  $V_{SS} = 0\text{ V}$ ,  $T_a = 25^\circ\text{C} \pm 5^\circ\text{C}$ )

Item	Symbol	Min	Max	Unit
Command write cycle	$t_{nxtc}$	20	—	$\mu\text{s}$
$\overline{\text{CE}}$ hold time	$t_{ceh}$	0	—	ns
$\overline{\text{CE}}$ setup time	$t_{ces}$	0	—	ns
Data hold time	$t_{dh}$	50	—	ns
Data setup time	$t_{ds}$	50	—	ns
Write pulse width	$t_{wep}$	70	—	ns
$\overline{\text{OE}}$ output delay time	$t_{oe}$	—	150	ns
Disable delay time	$t_{df}$	—	100	ns
$\overline{\text{CE}}$ output delay time	$t_{ce}$	—	150	ns
$\overline{\text{WE}}$ rise time	$t_r$	—	30	ns
$\overline{\text{WE}}$ fall time	$t_f$	—	30	ns

**Figure 7.22 Status Read Mode Timing Waveforms**

**Table 7.18 Status Read Mode Return Commands**

Pin Name	FO7	FO6	FO5	FO4	FO3	FO2	FO1	FO0
Attribute	Normal end identification	Command error	Programming error	Erase error	—	—	Programming or erase count exceeded	Effective address error
Initial value	0	0	0	0	0	0	0	0
Indications	Normal end: 0 Abnormal end: 1	Command error: 1 Otherwise: 0	Programming error: 1 Otherwise: 0	Erase error: 1 Otherwise: 0	—	—	Count exceeded: 1 Otherwise: 0	Effective address error: 1 Otherwise: 0

Note: FO2 and FO3 are undefined.

### 7.8.8 Status Polling

- (1) The FO7 status polling flag indicates the operating status in auto-program or auto-erase mode.
- (2) The FO6 status polling flag indicates a normal or abnormal end in auto-program or auto-erase mode.

**Table 7.19 Status Polling Output Truth Table**

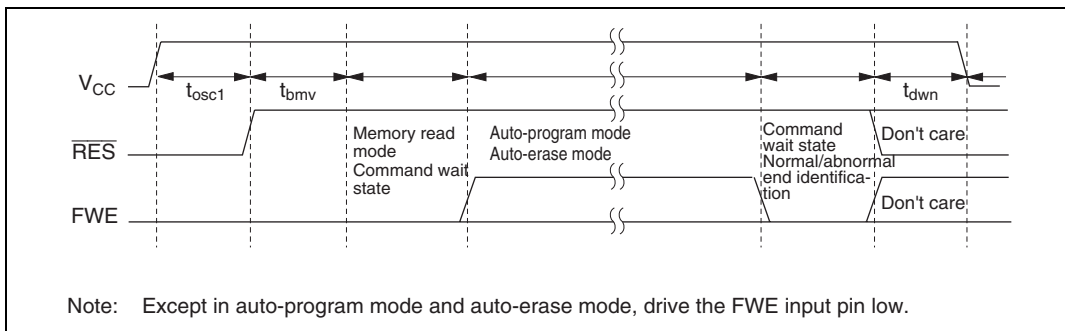
Pin Names	Internal Operation in Progress	Abnormal End	—	Normal End
FO7	0	1	0	1
FO6	0	0	1	1
FO0 to FO5	0	0	0	0

### 7.8.9 Programmer Mode Transition Time

Commands cannot be accepted during the oscillation stabilization period or the programmer mode setup period. After the programmer mode setup time, a transition is made to memory read mode.

**Table 7.20 Command Wait State Transition Time Specifications**

Item	Symbol	Min	Max	Unit
Standby release (oscillation stabilization time)	$t_{osc1}$	10	—	ms
Programmer mode setup time	$t_{bmv}$	10	—	ms
$V_{CC}$ hold time	$t_{dwn}$	0	—	ms



**Figure 7.23 Oscillation Stabilization Time, Boot Program Transfer Time, and Power Supply Fall Sequence**

### 7.8.10 Notes On Memory Programming

- (1) When programming addresses which have previously been programmed, carry out auto-erasing before auto-programming.
- (2) When performing programming using programmer mode on a chip that has been programmed/erased in an on-board programming mode, auto-erasing is recommended before carrying out auto-programming.

Notes: 1. The flash memory is initially in the erased state when the device is shipped by Renesas. For other chips for which the erasure history is unknown, it is recommended that auto-erasing be executed to check and supplement the initialization (erase) level.

2. Auto-programming should be performed once only on the same address block.

## 7.9 Flash Memory Programming and Erasing Precautions

Precautions concerning the use of on-board programming mode and programmer mode are summarized below.

(1) Use the specified voltages and timing for programming and erasing

Applied voltages in excess of the rating can permanently damage the device. Use a PROM programmer that supports Renesas Technology microcomputer device type with 128-kbyte on-chip flash memory.

Do not select the HN28F101 setting for the PROM programmer, and only use the specified socket adapter. Incorrect use will result in damaging the device.

(2) Powering on and off

Do not apply a high level to the FWE pin until  $V_{CC}$  has stabilized. Also, drive the FWE pin low before turning off  $V_{CC}$ .

When applying or disconnecting  $V_{CC}$ , fix the FWE pin low and place the flash memory in the hardware protection state.

The power-on and power-off timing requirements should also be satisfied in the event of a power failure and subsequent recovery.

(3) FWE application/disconnection

FWE application should be carried out when MCU operation is in a stable condition. If MCU operation is not stable, fix the FWE pin low and set the protection state.

The following points must be observed concerning FWE application and disconnection to prevent unintentional programming or erasing of flash memory:

- (a) Apply FWE when the  $V_{CC}$  voltage has stabilized within its rated voltage range.
- (b) In boot mode, apply and disconnect FWE during a reset.
- (c) In user program mode, FWE can be switched between high and low level regardless of the reset state. FWE input can also be switched during program execution in flash memory.
- (d) Do not apply FWE if program runaway has occurred.
- (e) Disconnect FWE only when the SWE, ESU, PSU, EV, PV, P, and E bits in FLMCR1 and FLMCR2 are cleared.

Make sure that the SWE, ESU, PSU, EV, PV, P, and E bits are not set by mistake when applying or disconnecting FWE.

(4) Do not apply a constant high level to the FWE pin

Apply a high level to the FWE pin only when programming or erasing flash memory. A system configuration in which a high level is constantly applied to the FWE should be avoided. Also, while a high level is applied to the FWE pin, the watchdog timer should be activated to prevent overprogramming or overerasing due to program runaway, etc.

- (5) Use the recommended algorithm when programming and erasing flash memory  
The recommended algorithm enables programming and erasing to be carried out without subjecting the device to voltage stress or sacrificing program data reliability. When setting the P or E bit in FLMCR1, the watchdog timer should be set beforehand as a precaution against program runaway, etc.
- (6) Do not set or clear the SWE bit during program execution in flash memory  
Clear the SWE bit before executing a program or reading data in flash memory.  
When the SWE bit is set, data in flash memory can be rewritten, but flash memory should only be accessed for verify operations (verification during programming/erasing).
- (7) Do not use interrupts while flash memory is being programmed or erased  
All interrupt requests, including NMI, should be disabled during FWE application to give priority to program/erase operations.
- (8) Do not perform additional aprogramming. Erase the memory before reprogramming.  
In on-board programming, perform only one programming operation on a 32-byte programming unit block. In programmer mode, too, perform only one programming operation on a 128-byte programming unit block. Programming should be carried out with the entire programming unit block erased.
- (9) Before programming, check that the chip is correctly mounted in the PROM programmer.  
Overcurrent damage to the device can result if the index marks on the PROM programmer socket, socket adapter, and chip are not correctly aligned.
- (10) Do not touch the socket adapter or chip during programming.  
Touching either of these can cause contact faults and write errors.

## 7.10 Note on Switching from F-ZTAT Version to Mask ROM Version

The mask ROM version does not have the internal registers for flash memory control that are provided in the F-ZTAT version. Table 7.21 lists the registers that are present in the F-ZTAT version but not in the mask ROM version. If a register listed in table 7.21 is read in the mask ROM version, an undefined value will be returned. Therefore, if application software developed on the F-ZTAT version is switched to a mask ROM version product, it must be modified to ensure that the registers in table 7.21 have no effect.

**Table 7.21 Registers Present in F-ZTAT Version but Absent in Mask ROM Version**

<b>Register</b>	<b>Abbreviation</b>	<b>Address</b>
Flash memory control register 1	FLMCR1	H'FFF8
Flash memory control register 2	FLMCR2	H'FFF9
Erase block register 1	EBR1	H'FFFA
Erase block register 2	EBR2	H'FFFB

## Section 8 ROM (H8S/2194C Group)

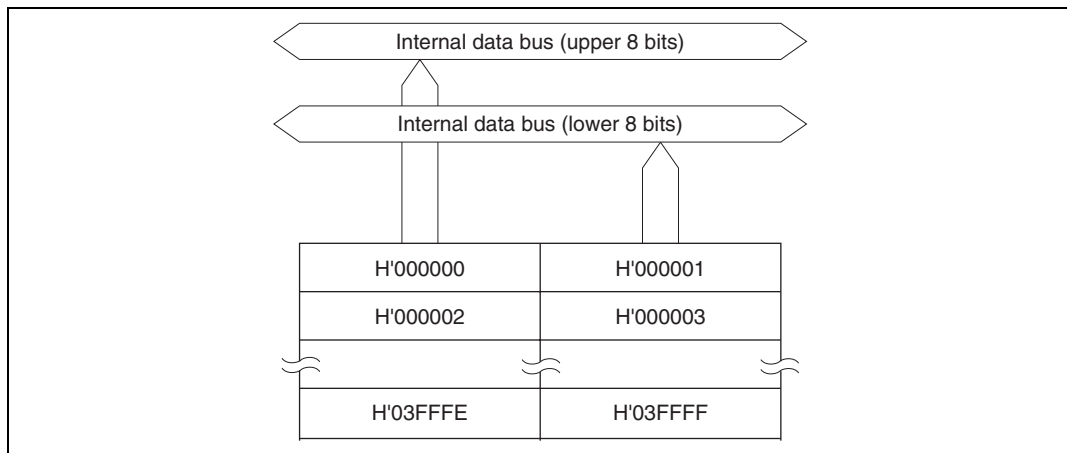
### 8.1 Overview

The H8S/2194C has 256 kbytes of on-chip ROM (flash memory or mask ROM), the H8S/2194B has 192 kbytes, the H8S/2194A has 160 kbytes. The ROM is connected to the CPU by a 16-bit data bus. The CPU accesses both byte and word data in one state, enabling faster instruction fetches and higher processing speed.

The flash memory versions of the H8S/2194C can be erased and programmed on-board as well as with a general-purpose PROM programmer.

#### 8.1.1 Block Diagram

Figure 8.1 shows a block diagram of the ROM.



**Figure 8.1 ROM Block Diagram (H8S/2194C)**

## 8.2 Overview of Flash Memory

### 8.2.1 Features

The features of the flash memory are summarized below.

- Four flash memory operating modes
  - Program mode
  - Erase mode
  - Program-verify mode
  - Erase-verify mode
- Programming/erase methods

The flash memory is programmed 32 bytes at a time. Erasing is performed by block erase (in single-block units). When erasing all blocks, the individual blocks must be erased sequentially. Block erasing can be performed as required on 1-kbyte, 8-kbyte, 16-kbyte, 28-kbyte, and 32-kbyte blocks.
- Programming/erase times

The flash memory programming time is 10 ms (typ.) for simultaneous 32-byte programming, equivalent to 300  $\mu$ s (typ.) per byte, and the erase time is 100 ms (typ.) per block.
- Reprogramming capability

The flash memory can be reprogrammed up to 100 times.
- On-board programming modes

There are two modes in which flash memory can be programmed/erased/verified on-board:

  - Boot mode
  - User program mode
- Automatic bit rate adjustment

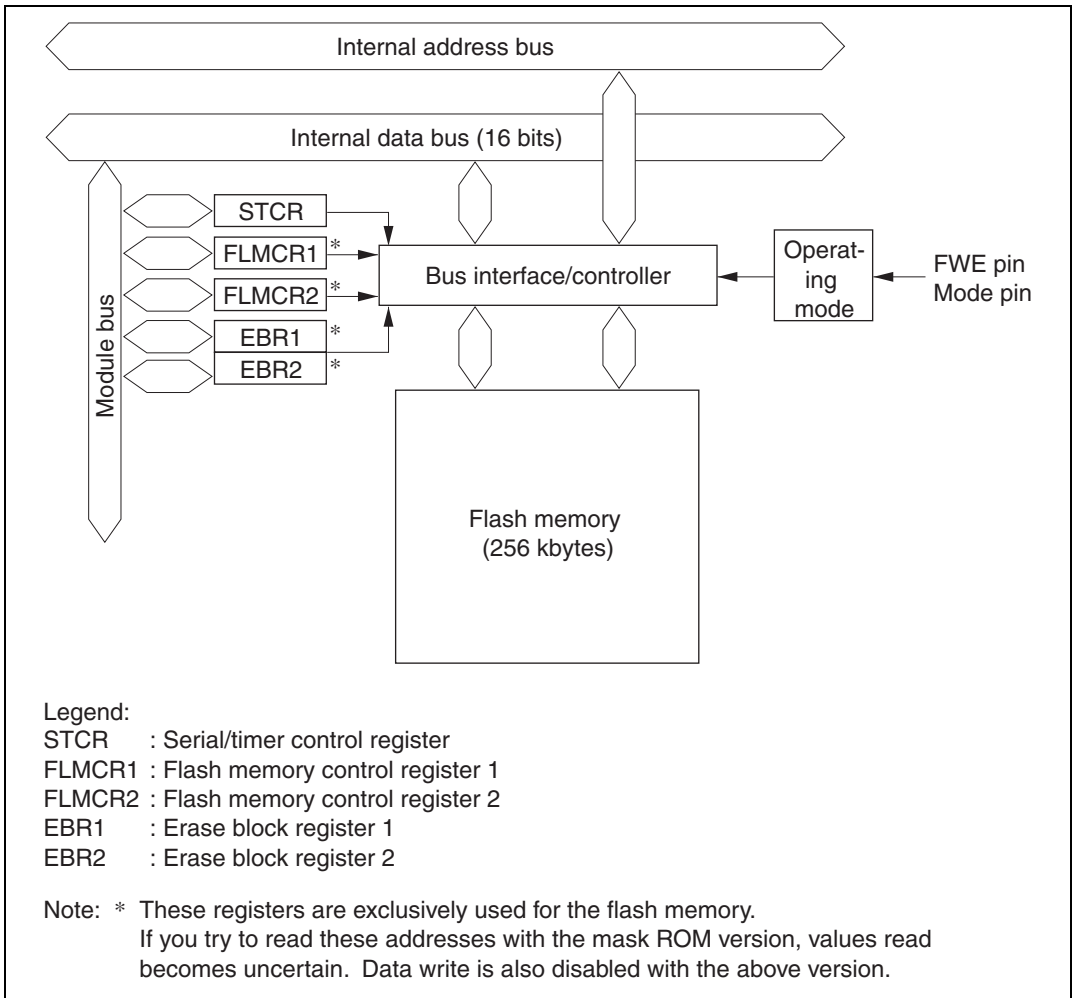
If data transfer on boot mode, automatic adjustment is possible at host transfer bit rates and MCU's bit rates.
- Protect modes

There are three protect modes, hardware, software, and error protect, which allow protected status to be designated for flash memory program/erase/verify operations.
- Programmer mode

Flash memory can be programmed/erased in programmer mode, using a PROM programmer, as well as in on-board programming mode.



## 8.2.2 Block Diagram



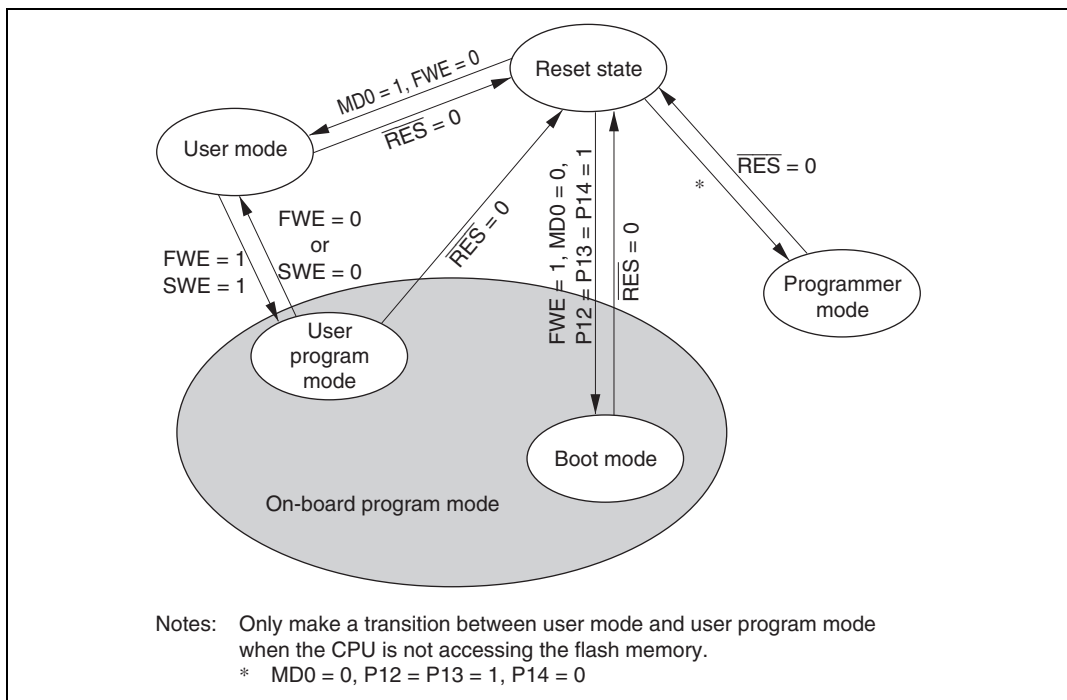
**Figure 8.2 Block Diagram of Flash Memory**

### 8.2.3 Flash Memory Operating Modes

#### (1) Mode Transitions

When each mode pin and the FWE pin are set in the reset state and a reset-start is executed, the MCU enters one of the operating modes shown in figure 8.3. In user mode, flash memory can be read but not programmed or erased.

Flash memory can be programmed and erased in boot mode, user program mode, and programmer mode.



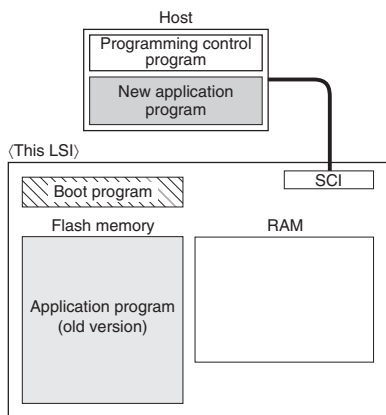
**Figure 8.3 Flash Memory Mode Transitions**

## (2) On-Board Programming Modes

## (a) Boot mode

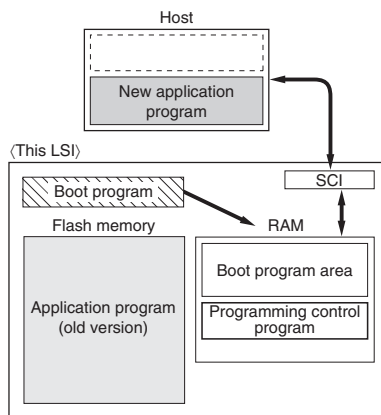
## 1. Initial state

The old program version or data remains written in the flash memory. The user should prepare the programming control program and new application program beforehand in the host.



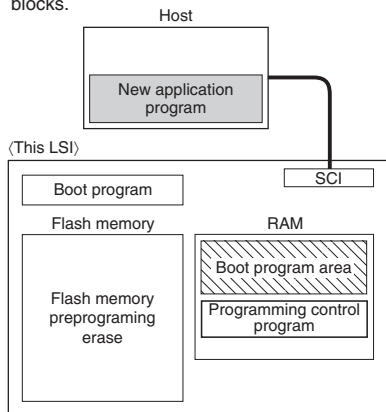
## 2. Programming control program transfer

When boot mode is entered, the boot program in the LSI (originally incorporated in the chip) is started and the programming control program in the host is transferred to RAM via SCI communication. The boot program required for flash memory erasing is automatically transferred to the RAM boot program area.



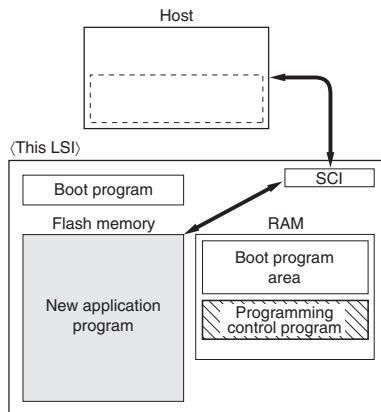
## 3. Flash memory initialization


The erase program in the boot program area (in RAM) is executed, and the flash memory is initialized (to H'FF). In boot mode, entire flash memory erasure is performed, without regard to blocks.



## 4. Writing new application program

The programming control program transferred from the host to RAM is executed, and the new application program in the host is written into the flash memory.



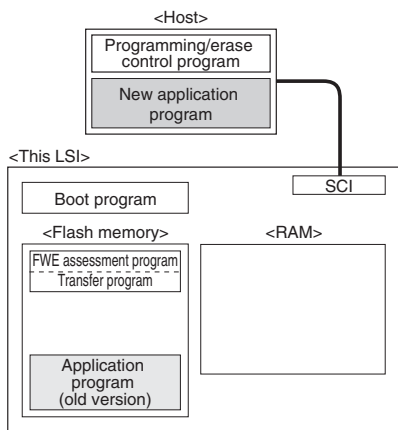
 Program execution state

**Figure 8.4 Boot Mode**

## (b) User program mode

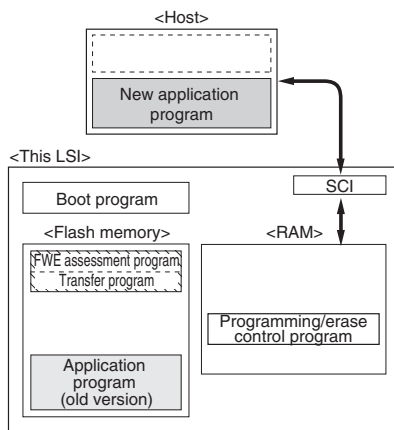
## 1. Initial state

(1) The FWE assessment program that confirms that the FWE pin has been driven high, and (2) the program that will transfer the programming/erase control program from the flash memory to on-chip RAM should be written into the flash memory by the user beforehand. (3) The programming/erase control program should be prepared in the host or in the flash memory.



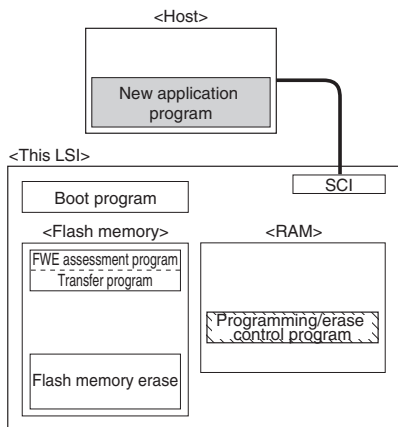
## 2. Programming/erase control program transfer

When user program mode is entered, user software confirms this fact, executes the transfer program in the flash memory, and transfers the programming/erase control program to RAM.



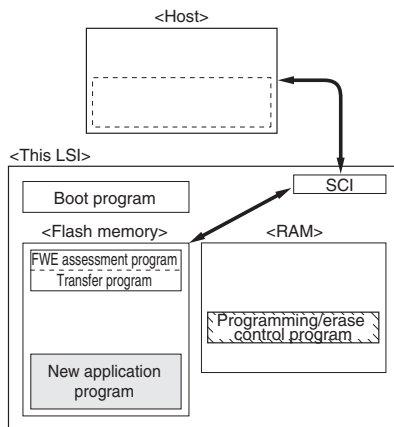
## 3. Flash memory initialization


The programming/erase control program in RAM is executed, and the flash memory is initialized (to H'FF). Erasing can be performed in block units, but not in byte units.



## 4. Writing new application program

Next, the new application program in the host is written into the erased flash memory blocks. Do not write to unerased blocks.



 Program execution state

**Figure 8.5 User Program Mode (Example)**

## (3) Differences between Boot Mode and User Program Mode

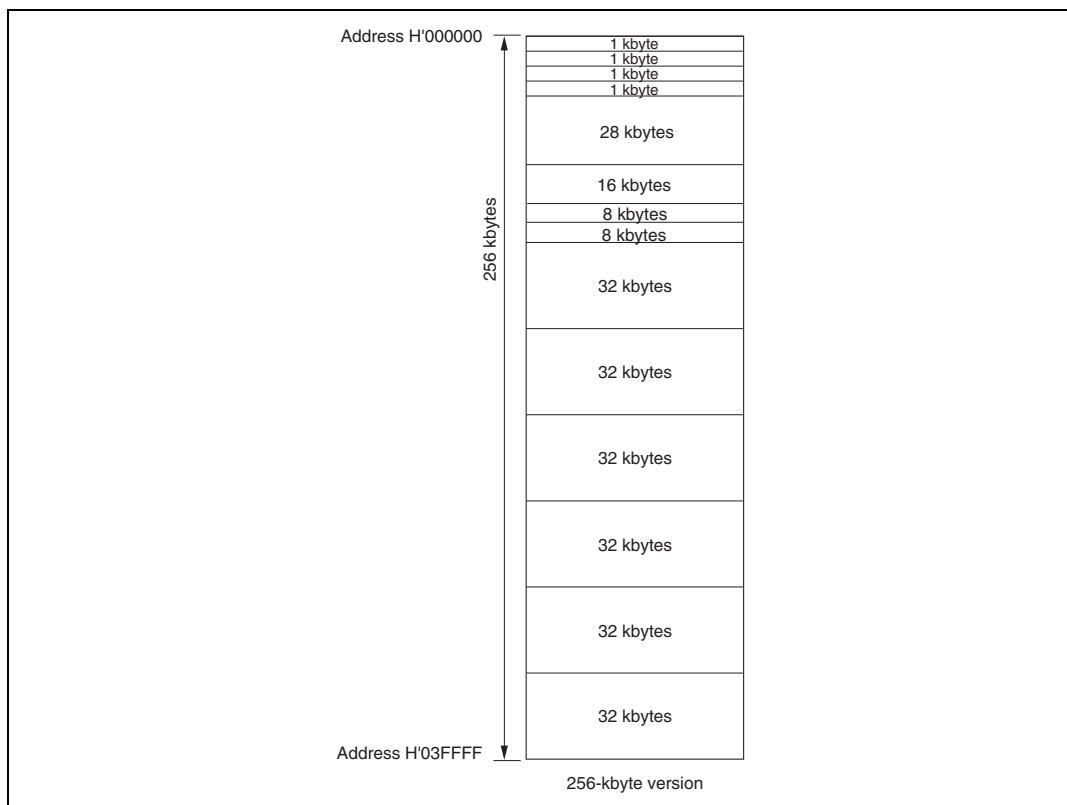
**Table 8.1 Differences between Boot Mode and User Program Mode**

	<b>Boot Mode</b>	<b>User Program Mode</b>
Entire memory erase <sup>ω</sup>	Yes	Yes
Block erase	No	Yes
Programming control program <sup>*</sup>	Program/program-verify	Erase/erase-verify Program/program-verify

Note: \* To be provided by the user, in accordance with the recommended algorithm.

## (4) Block Configuration

The flash memory is divided into six 32-kbyte blocks, two 8-kbyte blocks, one 16-kbyte block, one 28-kbyte block, and four 1-kbyte blocks.

**Figure 8.6 Flash Memory Block Configuration**

### 8.2.4 Pin Configuration

The flash memory is controlled by means of the pins shown in table 8.2.

**Table 8.2 Flash Memory Pins**

Pin Name	Abbreviation	I/O	Function
Reset	$\overline{\text{RES}}$	Input	Reset
Flash write enable	FWE	Input	Flash program/erase protection by hardware
Mode 0	MD0	Input	Sets this LSI operating mode
Port 12	P12	Input	Sets this LSI operating mode when MD0 = 0
Port 13	P13	Input	Sets this LSI operating mode when MD0 = 0
Port 14	P14	Input	Sets this LSI operating mode when MD0 = 0
Transmit data	SO1	Output	Serial transmit data output
Receive data	SI1	Input	Serial receive data input

### 8.2.5 Register Configuration

The registers used to control the on-chip flash memory when enabled are shown in table 8.3. In order to access these registers, the FLSHE bit in STCR must be set to 1.

**Table 8.3 Flash Memory Registers**

Register Name	Abbreviation	R/W	Initial Value	Address <sup>*5</sup>
Flash memory control register 1	FLMCR1 <sup>*4</sup>	R/W <sup>*1</sup>	H'00 <sup>*2</sup>	H'FFF8
Flash memory control register 2	FLMCR2 <sup>*4</sup>	R/W <sup>*1</sup>	H'00 <sup>*3</sup>	H'FFF9
Erase block register 1	EBR1 <sup>*4</sup>	R/W <sup>*1</sup>	H'00 <sup>*3</sup>	H'FFFA
Erase block register 2	EBR2 <sup>*4</sup>	R/W <sup>*1</sup>	H'00 <sup>*3</sup>	H'FFFB
Serial/timer control register	STCR	R/W	H'00	H'FFEE

- Notes:
1. When the FWE bit in FLMCR1 is not set at 1, writes are disabled.
  2. When a high level is input to the FWE pin, the initial value is H'80.
  3. When a low level is input to the FWE pin, or if a high level is input and the SWE bit in FLMCR1 is not set, these registers are initialized to H'00.
  4. FLMCR1, FLMCR2, EBR1, and EBR2 are 8-bit registers. Only byte accesses are valid for these registers, the access requiring 2 states.
  5. Lower 16 bits of the address.

## 8.3 Flash Memory Register Descriptions

### 8.3.1 Flash Memory Control Register 1 (FLMCR1)

Bit:	7	6	5	4	3	2	1	0
	FWE	SWE	ESU1	PSU1	EV1	PV1	E1	P1
Initial value:	—*	0	0	0	0	0	0	0
R/W:	R	R/W	R/W	R/W	R/W	R/W	R/W	R/W

Note: \* Determined by the state of the FWE pin.

FLMCR1 is an 8-bit register used for flash memory operating mode control. Program-verify mode or erase-verify mode for addresses H'00000 to H'1FFFF is entered by setting SWE to 1 while FWE is 1 and then setting the EV1 bit or PV1 bit. Program mode for addresses H'00000 to H'1FFFF is entered by setting SWE to 1 while FWE is 1, then setting the PSU1 bit, and finally setting the P1 bit. Erase mode for addresses H'00000 to H'1FFFF is entered by setting SWE to 1 while FWE is 1, then setting the ESU1 bit, and finally setting the E1 bit. FLMCR1 is initialized by a reset, in power-down state (excluding the medium-speed mode, module stop mode, and sleep mode), or when a low level is input to the FWE pin. When a high level is input to the FWE pin, its initial value is H'80 and when a low level is input, its initial value is H'00.

Writes to the SWE, ESU1, PSU1, EV1, and PV1 bits in FLMCR1 are enabled only when FWE = 1 and SWE = 1; writes to the E1 bit only when FWE = 1, SWE = 1, and ESU1 = 1; and writes to the P1 bit only when FWE = 1, SWE = 1, and PSU1 = 1.

**Bit 7—Flash Write Enable (FWE):** Sets hardware protection against flash memory programming/erasing.

#### Bit 7

FWE	Description
0	When a low level is input to the FWE pin (hardware-protected state)
1	When a high level is input to the FWE pin

**Bit 6—Software Write Enable (SWE):** Enables or disables flash memory programming. SWE should be set before setting bits 5 to 0, bits 5 to 0 in FLMCR2, bits 5 to 0 in EBR1 and bits 7 to 0 in EBR2.

**Bit 6**

<b>SWE</b>	<b>Description</b>
0	Writes are disabled (Initial value)
1	Writes are enabled [Setting condition] Setting is available when FWE = 1 is selected

**Bit 5—Erase-Setup Bit 1 (ESU1):** Prepares erase-mode transition for addresses H'00000 to H'1FFFF. Set ESU1 to 1 before setting the E1 bit to 1. Do not set the SWE, PSU1, EV1, PV1, E1, or P1 bit at the same time.

**Bit 5**

<b>ESU1</b>	<b>Description</b>
0	Erase-setup cleared (Initial value)
1	Erase-setup [Setting condition] When FWE = 1 and SWE = 1

**Bit 4—Program-Setup Bit 1 (PSU1):** Prepares erase-mode transition for addresses H'00000 to H'1FFFF. Set PSU1 to 1 before setting the P1 bit to 1. Do not set the SWE, ESU1, EV1, PV1, E1, or P1 bit at the same time.

**Bit 4**

<b>PSU1</b>	<b>Description</b>
0	Program-setup cleared (Initial value)
1	Program-setup [Setting condition] When FWE = 1 and SWE = 1



**Bit 3—Erase-Verify (EV1):** Selects erase-verify mode transition or clearing. Do not set the SWE, ESU1, PSU1, PV1, E1, or P1 bit at the same time.

**Bit 3**

<b>EV1</b>	<b>Description</b>
0	Erase-verify mode cleared (Initial value)
1	Transition to erase-verify mode [Setting condition] Setting is available when FWE = 1 and SWE = 1 are selected

**Bit 2—Program-Verify (PV1)**

Selects program-verify mode transition or clearing. Do not set the SWE, ESU1, PSU1, EV1, E1, or P1 bit at the same time.

**Bit 2**

<b>PV1</b>	<b>Description</b>
0	Program-verify mode cleared (Initial value)
1	Transition to program-verify mode [Setting condition] Setting is available when FWE = 1 and SWE = 1 are selected

**Bit 1—Erase (E1):** Selects erase mode transition or clearing. Do not set the SWE, ESU1, PSU1, EV1, PV1, or P1 bit at the same time.

**Bit 1**

<b>E1</b>	<b>Description</b>
0	Erase mode cleared (Initial value)
1	Transition to erase mode [Setting condition] Setting is available when FWE = 1, SWE = 1, and ESU = 1 are selected

**Bit 0—Program (P1):** Selects program mode transition or clearing. Do not set the SWE, PSU1, ESU1, EV1, PV1, or E1 bit at the same time.

**Bit 0**

<b>P1</b>	<b>Description</b>
0	Program mode cleared (Initial value)
1	Transition to program mode [Setting condition] Setting is available when FWE = 1, SWE = 1, and PSU = 1 are selected

---

### 8.3.2 Flash Memory Control Register 2 (FLMCR2)

Bit :	7	6	5	4	3	2	1	0
	FLER	—	ESU2	PSU2	EV2	PV2	E2	P2
Initial value :	0	0	0	0	0	0	0	0
R/W :	R	—	R/W	R/W	R/W	R/W	R/W	R/W

FLMCR2 is an 8-bit register used for flash memory operating mode control. Program-verify mode or erase-verify mode for addresses H'20000 to H'3FFFF is entered by setting SWE in FLMCR1 to 1 while FWE in FLMCR1 is 1 and then setting the EV2 bit or PV2 bit. Program mode for addresses H'20000 to H'3FFFF is entered by setting SWE in FLMCR1 to 1 while FWE in FLMCR1 is 1, then setting the PSU2 bit, and finally setting the P2 bit. Erase mode for addresses H'20000 to H'3FFFF is entered by setting SWE in FLMCR1 to 1 while FWE in FLMCR1 is 1, then setting the ESU2 bit, and finally setting the E2 bit. FLMCR2 is initialized to H'00 by a reset, in power-down state (excluding the medium-speed mode, module stop mode, and sleep mode), when a low level is input to the FWE pin, or when a high level is input to the FWE pin and the SWE bit in FLMCR1 is not set. However, FLER is initialized only by a reset.

Writes to the ESU2, PSU2, EV2, and PV2 bits in FLMCR2 are enabled only when FWE in FLMCR1 = 1 and SWE in FLMCR1 = 1; writes to the E2 bit only when FWE in FLMCR1 = 1, SWE in FLMCR1 = 1, and ESU2 = 1; and writes to the P2 bit only when FWE in FLMCR1 = 1, SWE in FLMCR1 = 1, and PSU2 = 1.

**Bit 7—Flash Memory Error (FLER):** Indicates that an error has occurred during an operation on flash memory (programming or erasing). When FLER is set to 1, flash memory goes to the error-protection state.

#### Bit 7

FLER	Description
0	Flash memory is operating normally Flash memory program/erase protection (error protection) is disabled [Clearing condition] Reset or hardware standby mode (Initial value)
1	An error has occurred during flash memory programming/erasing Flash memory program/erase protection (error protection) is enabled [Setting condition] See section 8.6.3, Error Protection

**Bit 6—Reserved:** This bit cannot be modified and is always read as 0.

**Bit 5—Erase-Setup Bit 2 (ESU2):** Prepares erase-mode transition for addresses H'20000 to H'3FFFF. Set ESU2 to 1 before setting the E2 bit to 1. Do not set the PSU2, EV2, PV2, E2, or P2 bit at the same time.

**Bit 5**

ESU2	Description
0	Erase-setup cleared (Initial value)
1	Erase-setup [Setting condition] When FWE = 1 and SWE = 1

**Bit 4—Program-Setup Bit 2 (PSU2):** Prepares erase-mode transition for addresses H'20000 to H'3FFFF. Set PSU2 to 1 before setting the P2 bit to 1. Do not set the ESU2, EV2, PV2, E2, or P2 bit at the same time.

**Bit 4**

PSU2	Description
0	Program-setup cleared (Initial value)
1	Program-setup [Setting condition] When FWE = 1 and SWE = 1

**Bit 3—Erase-Verify 2 (EV2):** Selects erase-verify mode transition or clearing for addresses H'20000 to H'3FFFF. Do not set the ESU2, PSU2, PV2, E2, or P2 bit at the same time.

**Bit 3**

EV2	Description
0	Erase-verify mode cleared (Initial value)
1	Transition to erase-verify mode [Setting condition] When FWE = 1 and SWE = 1

**Bit 2—Program-Verify 2 (PV2):** Selects program-verify mode transition or clearing for addresses H'20000 to H'3FFFF. Do not set the ESU2, PSU2, EV2, E2, or P2 bit at the same time.

**Bit 2**

<b>PV2</b>	<b>Description</b>
0	Program-verify mode cleared (Initial value)
1	Transition to program-verify mode [Setting condition] When FWE = 1 and SWE = 1

**Bit 1—Erase 2 (E2):** Selects erase mode transition or clearing for addresses H'20000 to H'3FFFF. Do not set the ESU2, PSU2, EV2, PV2, or P2 bit at the same time.

**Bit 1**

<b>E2</b>	<b>Description</b>
0	Erase mode cleared (Initial value)
1	Transition to erase mode [Setting condition] When FWE = 1, SWE = 1, and ESU2 = 1

**Bit 0—Program 2 (P2)**

Selects program-mode transition or clearing for addresses H'20000 to H'3FFFF. Do not set the ESU2, PSU2, EV2, PV2, or E2 bit at the same time.

**Bit 0**

<b>P2</b>	<b>Description</b>
0	Program-mode cleared (Initial value)
1	Transition to program-mode [Setting condition] When FWE = 1, SWE = 1, and PSU2 = 1

### 8.3.3 Erase Block Registers 1 (EBR1)

Bit :	7	6	5	4	3	2	1	0
EBR1 :	—	—	EB13	EB12	EB11	EB10	EB9	EB8
Initial value :	0	0	0	0	0	0	0	0
R/W :	—	—	R/W	R/W	R/W	R/W	R/W	R/W

EBR1 is a register that specifies the flash memory erase area block by block. EBR1 is initialized to H'00 by a reset, in power-down state (excluding the medium-speed mode, module stop mode, and sleep mode), when a low level is input to the FWE pin, or when a high level is input to the FWE pin and the SWE bit in FLMCR1 is not set. When a bit in EBR1 is set, the corresponding block can be erased. Other blocks are erase-protected. Set only one bit in EBR1 or EBR2 (more than one bit cannot be set).

The flash memory block configuration is shown in table 8.3.

### 8.3.4 Erase Block Registers 2 (EBR2)

Bit :	7	6	5	4	3	2	1	0
EBR2 :	EB7	EB6	EB5	EB4	EB3	EB2	EB1	EB0
Initial value :	0	0	0	0	0	0	0	0
R/W :	R/W	R/W	R/W	R/W	R/W	R/W	R/W	R/W

EBR2 is a register that specifies the flash memory erase area block by block. EBR2 is initialized to H'00 by a reset, in power-down state (excluding the medium-speed mode, module stop mode, and sleep mode), when a low level is input to the FWE pin, or when a high level is input to the FWE pin and the SWE bit in FLMCR1 is not set. When a bit in EBR2 is set, the corresponding block can be erased. Other blocks are erase-protected. Set only one bit in EBR1 or EBR2 (more than one bit cannot be set).

The flash memory block configuration is shown in table 8.4.

**Table 8.4 Flash Memory Erase Blocks**

<b>Block (Size)</b>	
<b>128-kbyte Versions</b>	<b>Address</b>
EB0 (1 kbyte)	H'000000 to H'0003FF
EB1 (1 kbyte)	H'000400 to H'0007FF
EB2 (1 kbyte)	H'000800 to H'000BFF
EB3 (1 kbyte)	H'000C00 to H'000FFF
EB4 (28 kbytes)	H'001000 to H'007FFF
EB5 (16 kbytes)	H'008000 to H'00BFFF
EB6 (8 kbytes)	H'00C000 to H'00DFFF
EB7 (8 kbytes)	H'00E000 to H'00FFFF
EB8 (32 kbytes)	H'010000 to H'017FFF
EB9 (32 kbytes)	H'018000 to H'01FFFF
EB10 (32 kbytes)	H'020000 to H'027FFF
EB11 (32 kbytes)	H'028000 to H'02FFFF
EB12 (32 kbytes)	H'030000 to H'037FFF
EB13 (32 kbytes)	H'038000 to H'03FFFF

### 8.3.5 Serial/Timer Control Register (STCR)

Bit	:	7	6	5	4	3	2	1	0
		—	IICX	IICRST	—	FLSHE	—	—	—
Initial value	:	0	0	0	0	0	0	0	0
R/W	:	—	R/W	R/W	—	R/W	—	—	—

STCR is an 8-bit readable/writable register that controls register access, the I<sup>2</sup>C bus interface operating mode, and on-chip flash memory (in F-ZTAT versions), and also selects the I<sup>2</sup>C bus interface serial clock frequency. For details on functions not related to on-chip flash memory, see section 25.2.7, Serial/Timer Control Register (STCR), and descriptions of individual modules. If a module controlled by STCR is not used, do not write 1 to the corresponding bit.

STCR is initialized to H'00 by a reset.

**Bits 6 and 5—I<sup>2</sup>C Control (IICX, IICRST):** These bits control the operation of the I<sup>2</sup>C bus interface. For details, see section 25, I<sup>2</sup>C Bus Interface (IIC).

**Bit 3—Flash Memory Control Register Enable (FLSHE):** Setting the FLSHE bit to 1 enables read/write access to the flash memory control registers. If FLSHE is cleared to 0, the flash memory control registers are deselected. In this case, the flash memory control register contents are retained.

**Bit 3**

FLSHE	Description	
0	Flash memory control registers deselected	(Initial value)
1	Flash memory control registers selected	

**Bits 7, 4 and 2 to 0—Reserved**

## 8.4 On-Board Programming Modes

When pins are set to on-board programming mode, program/erase/verify operations can be performed on the on-chip flash memory. There are two on-board programming modes: boot mode and user program mode. The pin settings for transition to each of these modes are shown in table 8.5. For a diagram of the transitions to the various flash memory modes, see figure 8.3.

**Table 8.5 Setting On-Board Programming Modes**

Mode	Pin				
	FWE	MD0	P12	P13	P14
Boot mode	1	0	1 <sup>*2</sup>	1 <sup>*2</sup>	1 <sup>*2</sup>
User program mode	1 <sup>*1</sup>	1	—	—	—

Notes: 1. In user program mode, the FWE pin should not be constantly set to 1. Set FWE to 1 to make a transition to user program mode before performing a program/erase/verify operation.

2. Can be used as I/O ports after boot mode is initiated.



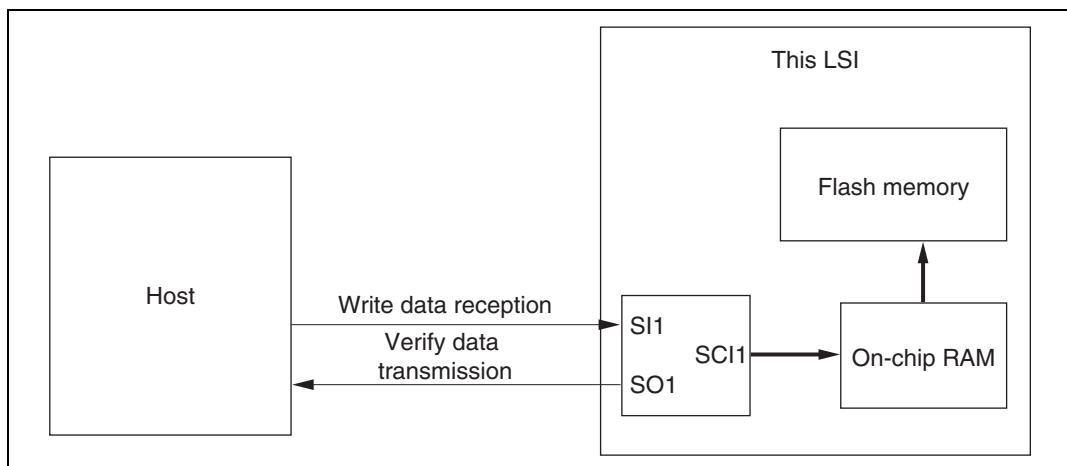
### 8.4.1 Boot Mode

When boot mode is used, the flash memory programming control program must be prepared in the host beforehand. The channel 1 SCI to be used is set to asynchronous mode.

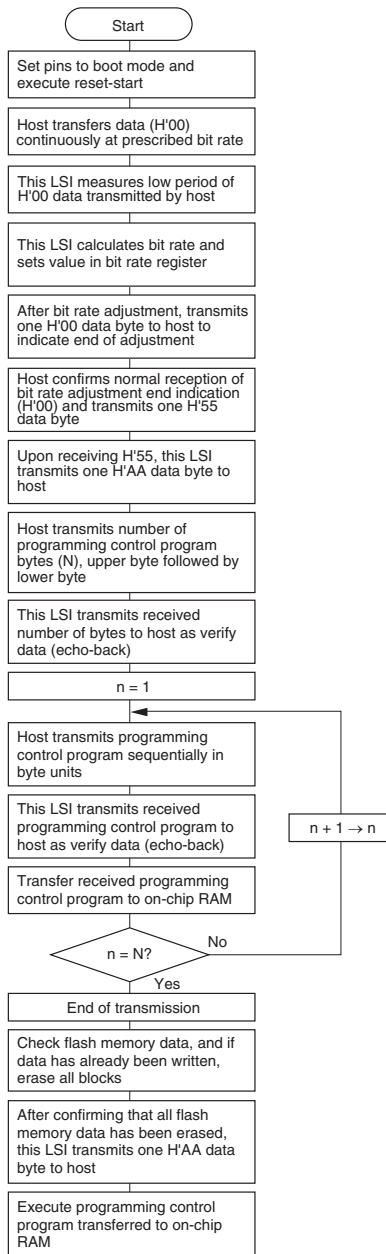
When a reset-start is executed after the MCU's pins have been set to boot mode, the boot program built into the MCU is started and the programming control program prepared in the host is serially transmitted to the MCU via the SCI1. In the MCU, the programming control program received via the SCI1 is written into the programming control program area in on-chip RAM. After the transfer is completed, control branches to the start address of the programming control program area and the programming control program execution state is entered (flash memory programming is performed).

The transferred programming control program must therefore include coding that follows the programming algorithm given later.

The system configuration in boot mode is shown in figure 8.7, and the boot program mode execution procedure in figure 8.8.



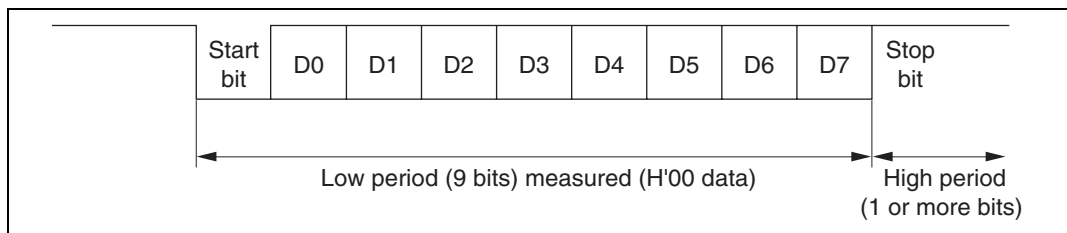
**Figure 8.7 System Configuration in Boot Mode**



Note : If a memory cell does not operate normally and cannot be erased, one H'FF byte is transmitted as an erase error, and the erase operation and subsequent operations are halted.

**Figure 8.8 Boot Mode Execution Procedure**

## (1) Automatic SCI Bit Rate Adjustment

**Figure 8.9 Automatic SCI Bit Rate Adjustment**

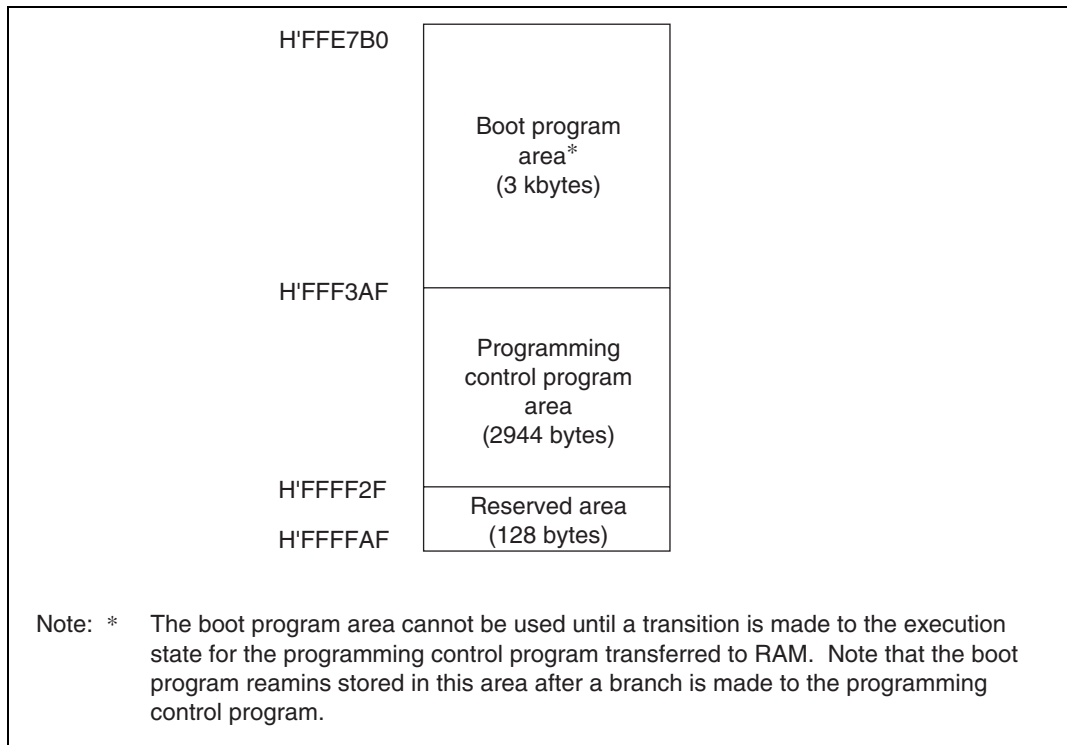
When boot mode is initiated, the MCU measures the low period of the asynchronous SCI communication data (H'00) transmitted continuously from the host. The SCI transmit/receive format should be set as follows: 8-bit data, 1 stop bit, no parity. The MCU calculates the bit rate of the transmission from the host from the measured low period, and transmits one H'00 byte to the host to indicate the end of bit rate adjustment. The host should confirm that this adjustment end indication (H'00) has been received normally, and transmit one H'55 byte to the MCU. If reception cannot be performed normally, initiate boot mode again (reset), and repeat the above operations. Depending on the host's transmission bit rate and the MCU's system clock frequency, there will be a discrepancy between the bit rates of the host and the MCU. To ensure correct SCI operation, the host's transfer bit rate should be set to (4800 or 9600) bps. Table 8.6 shows typical host transfer bit rates and system clock frequencies for which automatic adjustment of the MCU's bit rate is possible. The boot program should be executed within this system clock range.

**Table 8.6 System Clock Frequencies for which Automatic Adjustment of This LSI Bit Rate Is Possible**

<b>Host Bit Rate</b>	<b>System Clock Frequency for which Automatic Adjustment of This LSI Bit Rate is Possible</b>
9600 bps	8 MHz to 10 MHz
4800 bps	4 MHz to 10 MHz

## (2) On-Chip RAM Area Divisions in Boot Mode

In boot mode, the RAM area is divided into; the area for use by the boot program and the area to which programming control program is transferred by the SCI, as shown in figure 8.10. The boot program area cannot be used until a transition is made to the execution state in boot mode for the programming control program transferred to RAM.



**Figure 8.10 RAM Areas in Boot Mode**

## (3) Notes on Use of Boot Mode:

- (a) When reset is released in boot mode, it measures the low period of the input at the SCI1's SI1 pin. The reset should end with SI1 pin high. After the reset ends, it takes about 100 states for the chip to get ready to measure the low period of the SI1 pin input.
- (b) In boot mode, if any data has been programmed into the flash memory (if all data is not 1), all flash memory blocks are erased. Boot mode is for use when user program mode is unavailable, such as the first time on-board programming is performed, or if the program activated in user program mode is accidentally erased.
- (c) Interrupts cannot be used while the flash memory is being programmed or erased.
- (d) The SI1 and SO1 pins should be pulled up on the board.

- (e) Before branching to the programming control program (RAM area H'FFF3B0), the chip terminates transmit and receive operations by the on-chip SCI (channel 1) (by clearing the RE and TE bits in SCR to 0), but the adjusted bit rate value remains set in BRR. The transmit data output pin, SO1, goes to the high-level output state ( $P21PCR = 1$ ,  $P21PDR = 1$ ).

The contents of the CPU's internal general registers are undefined at this time, so these registers must be initialized immediately after branching to the programming control program. In particular, since the stack pointer (SP) is used implicitly in subroutine calls, etc., a stack area must be specified for use by the programming control program.

The initial values of other on-chip registers are not changed.

- (f) Boot mode can be entered by making the pin settings shown in table 8.6 and executing a reset-start.

When the chip detects the boot mode setting at reset release<sup>\*1</sup>, it retains that state internally.

Boot mode can be cleared by driving the reset pin low, waiting at least 20 states, then setting the FWE pin and mode pins, and executing reset release<sup>\*1</sup>. Boot mode can also be cleared by a WDT overflow reset.

If the mode pin input levels are changed in boot mode, the boot mode state will be maintained in the microcomputer, and boot mode continued, unless a reset occurs.

However, the FWE pin must not be driven low while the boot program is running or flash memory is being programmed or erased<sup>\*2</sup>.

- Notes: 1. Mode pin and FWE pin input must satisfy the mode programming setup time ( $t_{MDS} = 4$  states) with respect to the reset release timing.
2. For further information on FWE application and disconnection, see section 8.9, Flash Memory Programming and Erasing Precautions.

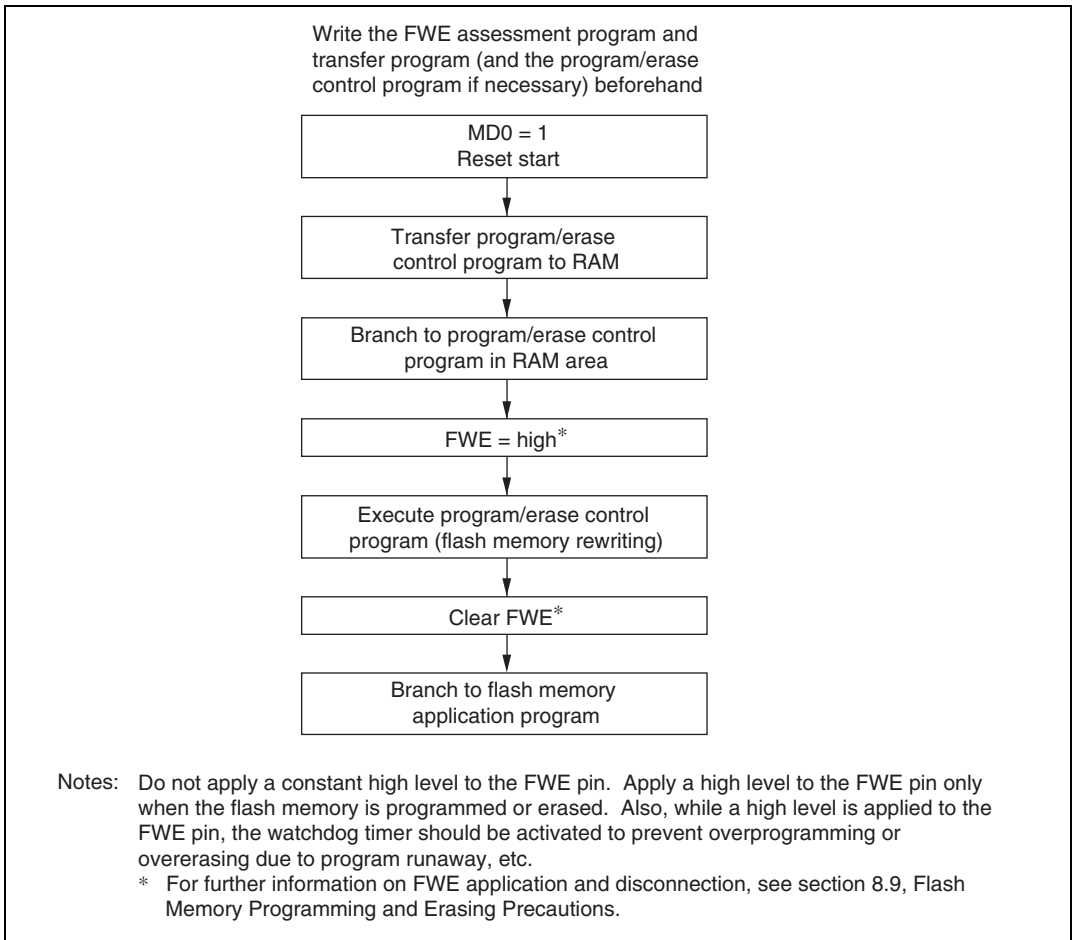
## 8.4.2 User Program Mode

When set to user program mode, the chip can program and erase its flash memory by executing a user program/erase control program. Therefore, on-board reprogramming of the on-chip flash memory can be carried out by providing on-board means of FWE control and supply of programming data, and storing a program/erase control program in part of the program area as necessary.

In this mode, the chip starts up in mode 1 and applies a high level to the FWE pin.

The flash memory itself cannot be read while the SWE bit is set to 1 to perform programming or erasing, so the control program that performs programming and erasing should be run in on-chip RAM or external memory.

Figure 8.11 shows the procedure for executing the program/erase control program when transferred to on-chip RAM.

**Figure 8.11 User Program Mode Execution Procedure (Preliminary)**

## 8.5 Programming/Erasing Flash Memory

In the on-board programming modes, flash memory programming and erasing is performed by software, using the CPU. There are four flash memory operating modes: program mode, erase mode, program-verify mode, and erase-verify mode. For addresses H'00000 to H'1FFFF, transitions to these modes can be made by setting the PSU1, ESU1, P1, E1, PV1 and EV1 bits in FLMCR1 and for addresses H'20000 to H'3FFFF, transitions to these modes can be made by setting the PSU2, ESU2, P2, E2, PV2, and EV2 bits in FLMCR2.

The flash memory cannot be read while being programmed or erased. Therefore, the program that controls flash memory programming/erasing (the programming control program) should be located and executed in on-chip RAM or external memory.

- Notes:
1. Operation is not guaranteed if setting/resetting of the SWE, ESU1, PSU1, EV1, PV1, E1, and P1 bits in FLMCR1, and the ESU2, PSU2, EV2, PV2, E2 and P2 bits in FLMCR2, is executed by a program in flash memory.
  2. When programming or erasing, set FWE to 1 (programming/erasing will not be executed if FWE = 0).
  3. Perform programming in the erased state. Do not perform additional programming on previously programmed addresses.  
Do not program addresses H'00000 to H'1FFFF and H'20000 to H'3FFFF at the same time. Operation is not guaranteed if both areas are programmed at the same time.

### 8.5.1 Program Mode (n = 1 for Addresses H'00000 to H'1FFFF and n = 2 for Addresses H'20000 to H'3FFFF)

Follow the procedure shown in the program/program-verify flowchart in figure 8.12 to write data or programs to flash memory. Performing program operations according to this flowchart will enable data or programs to be written to flash memory without subjecting the device to voltage stress or sacrificing program data reliability. Programming should be carried out 32 bytes at a time.

Table 29.12 lists wait time (x, y, z,  $\alpha$ ,  $\beta$ ,  $\gamma$ ,  $\epsilon$ , and  $\eta$ ) after setting or clearing each bit on the flash memory control registers 1 and 2 (FLMCR1 and FLMCR2) and the maximum write count (N). Following the elapse of (x)  $\mu$ s or more after the SWE bit is set to 1 in flash memory control register 1 (FLMCR1), 32-byte program data is stored in the program data area and reprogram data area, and the 32-byte data in the reprogram data area written consecutively to the write addresses. The lower 8 bits of the first address written to must be H'00, H'20, H'40, H'60, H'80, H'A0, H'C0, or H'E0. Thirty-two consecutive byte data transfers are performed. The program address and program data are latched in the flash memory. A 32-byte data transfer must be performed even if writing fewer than 32 bytes; in this case, H'FF data must be written to the extra addresses. Next, the watchdog timer is set to prevent overprogramming in the event of program runaway, etc.

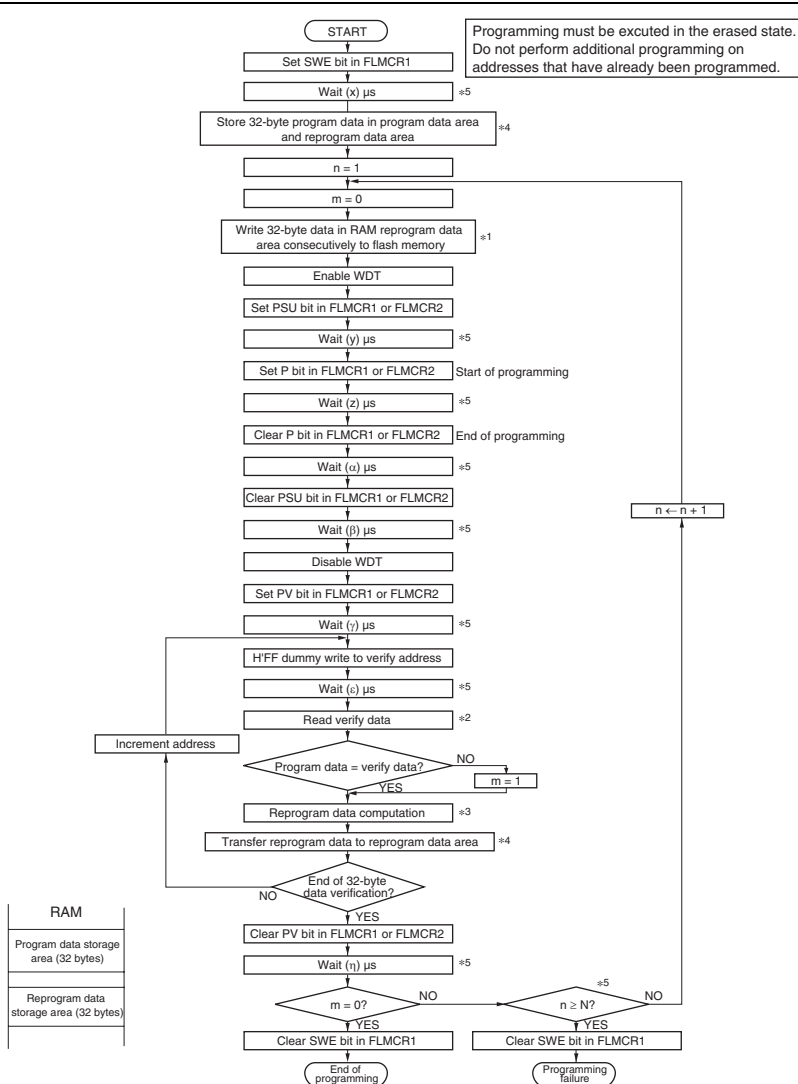
Set more than  $(y + z + \alpha + \beta)$   $\mu\text{s}$  as the WDT overflow period. After this, preparation for program mode (program setup) is carried out by setting the PSUn bit in FLMCRn, and after the elapse of  $(y)$   $\mu\text{s}$  or more, the operating mode is switched to program mode by setting the Pn bit in FLMCRn. The time during which the Pn bit is set is the flash memory programming time. Make a program setting so that the time for one programming operation is within the range of  $(z)$   $\mu\text{s}$ .

### 8.5.2 Program-Verify Mode (n = 1 for Addresses H'00000 to H'1FFFF and n = 2 for Addresses H'20000 to H'3FFFF)

In program-verify mode, the data written in program mode is read to check whether it has been correctly written in the flash memory.

After the elapse of a given programming time, the programming mode is exited (the Pn bit in FLMCRn is cleared, then the PSUn bit in FLMCRn is cleared at least  $(\alpha)$   $\mu\text{s}$  later). The watchdog timer is cleared after the elapse of  $(\beta)$   $\mu\text{s}$  or more, and the operating mode is switched to program-verify mode by setting the PVn bit in FLMCRn. Before reading in program-verify mode, a dummy write of H'FF data should be made to the addresses to be read. The dummy write should be executed after the elapse of  $(\gamma)$   $\mu\text{s}$  or more. When the flash memory is read in this state (verify data is read in 16-bit units), the data at the latched address is read. Wait at least  $(\epsilon)$   $\mu\text{s}$  after the dummy write before performing this read operation. Next, the originally written data is compared with the verify data, and reprogram data is computed (see figure 8.12) and transferred to the reprogram data area. After 32 bytes of data have been verified, exit program-verify mode, wait for at least  $(\eta)$   $\mu\text{s}$ , then clear the SWE bit in FLMCR1. If reprogramming is necessary, set program mode again, and repeat the program/program-verify sequence as before. However, ensure that the program/program-verify sequence is not repeated more than  $(N)$  times on the same bits.





- Notes:
- Data transfer is performed by byte transfer. The lower 8 bits of the first address written to must be H'00, H'20, H'40, H'60, H'80, H'A0, H'C0, or H'E0. A 32-byte data transfer must be performed even if writing fewer than 32 bytes; in this case, HFF data must be written to the extra addresses.
  - Verify data is read in 16-bit (word) units.
  - Even in case of the bit which is already-programmed in the 32-byte programming loop, perform additional programming if the bit fails at the next verify.
  - An area for storing program data (32 bytes) and reprogram data (32 bytes) must be provided in RAM. The contents of the latter are rewritten as programming progresses.
  - The values of x, y, z, α, β, γ, ε, η, and N are listed in section 29.2.7, Flash Memory Characteristics.

Program data	Verify data	Reprogram data	Comments
0	0	1	Do not reprogram bits for which programming has been completed.
0	1	0	Programming incomplete; reprogramming should be performed.
1	0	1	Programming incomplete; reprogramming should be performed.
1	1	1	Still in erased state; no action

**Figure 8.12 Program/Program-Verify Flowchart**

### 8.5.3 Erase Mode (n = 1 for Addresses H'00000 to H'1FFFF and n = 2 for Addresses H'20000 to H'3FFFF)

Flash memory erasing should be performed block by block following the procedure shown in the erase/erase-verify flowchart (single-block erase) shown in figure 8.13.

Table 29.12 lists wait time ( $x$ ,  $y$ ,  $z$ ,  $\alpha$ ,  $\beta$ ,  $\gamma$ ,  $\epsilon$ , and  $\eta$ ) after setting or clearing each bit on the flash memory control registers 1 and 2 (FLMCR1 and FLMCR2) and the maximum clearing count ( $N$ ). To perform data or program erasure, make a 1 bit setting for the flash memory area to be erased in erase block register 1 or 2 (EBR1 or EBR2) at least ( $x$ )  $\mu$ s after setting the SWE bit to 1 in flash memory control register 1 (FLMCR1). Next, the watchdog timer is set to prevent overerasing in the event of program runaway, etc. Set more than ( $y + z + \alpha + \beta$ ) ms as the WDT overflow period. After this, preparation for erase mode (erase setup) is carried out by setting the ESUn bit in FLMCRn, and after the elapse of ( $y$ )  $\mu$ s or more, the operating mode is switched to erase mode by setting the En bit in FLMCRn. The time during which the En bit is set is the flash memory erase time. Ensure that the erase time does not exceed ( $z$ ) ms.

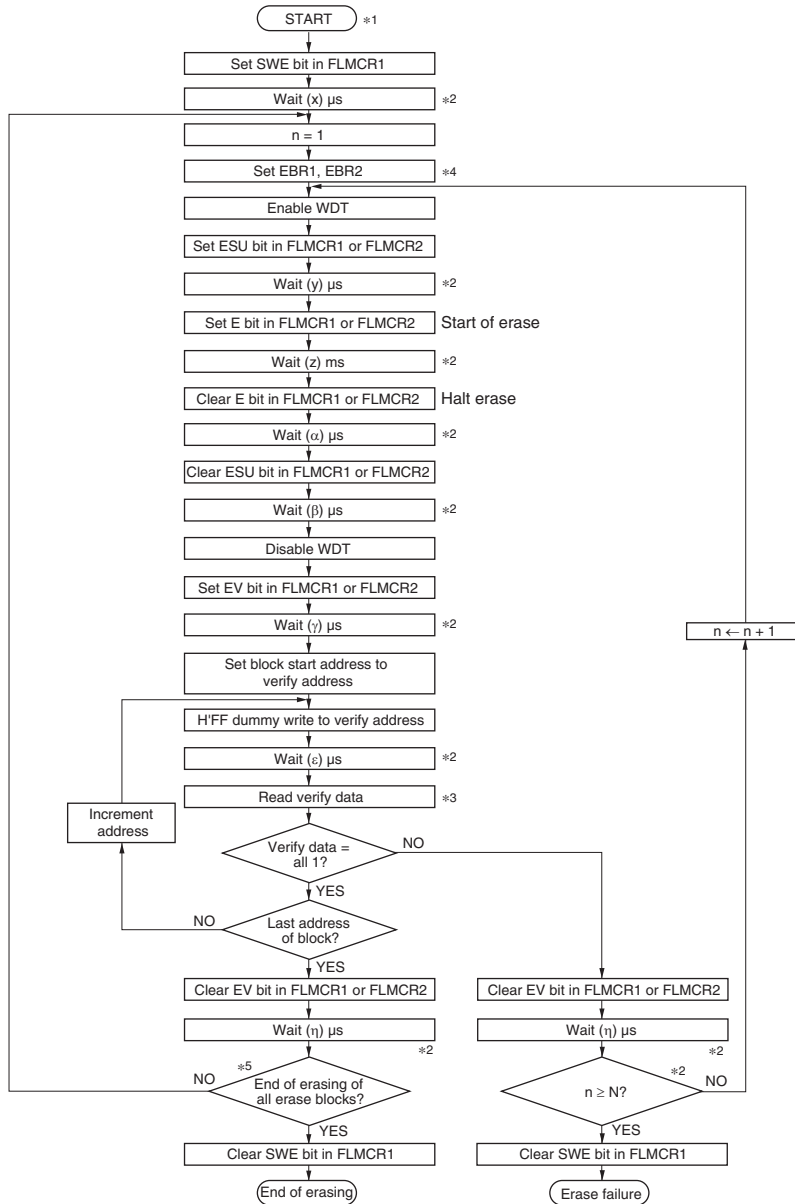
Note: With flash memory erasing, preprogramming (setting all data in the memory to be erased to 0) is not necessary before starting the erase procedure.

### 8.5.4 Erase-Verify Mode (n = 1 for Addresses H'00000 to H'1FFFF and n = 2 for Addresses H'20000 to H'3FFFF)

In erase-verify mode, data is read after memory has been erased to check whether it has been correctly erased.

After the elapse of the erase time, erase mode is exited (the En bit in FLMCRn is cleared, then the ESU bit in FLMCR2 is cleared at least ( $\alpha$ )  $\mu$ s later), the watchdog timer is cleared after the elapse of ( $\beta$ )  $\mu$ s or more, and the operating mode is switched to erase-verify mode by setting the EVn bit in FLMCRn. Before reading in erase-verify mode, a dummy write of H'FF data should be made to the addresses to be read. The dummy write should be executed after the elapse of ( $\gamma$ )  $\mu$ s or more.

When the flash memory is read in this state (verify data is read in 16-bit units), the data at the latched address is read. Wait at least ( $\epsilon$ )  $\mu$ s after the dummy write before performing this read operation. If the read data has been erased (all 1), a dummy write is performed to the next address, and erase-verify is performed. If the read data has not been erased, set erase mode again, and repeat the erase/erase-verify sequence in the same way. However, ensure that the erase/erase-verify sequence is not repeated more than ( $N$ ) times. When verification is completed, exit erase-verify mode, and wait for at least ( $\eta$ )  $\mu$ s. If erasure has been completed on all the erase blocks, clear the SWE bit in FLMCR1. If there are any unerased blocks, make a 1 bit setting in EBR1 or EBR2 for the flash memory area to be erased, and repeat the erase/erase-verify sequence in the same way.



- Notes:
1. Preprogramming (setting erase block data to all 0) is not necessary.
  2. The values of x, y, z, α, β, γ, ε, η, and N are listed in section 29.2.7, Flash Memory Characteristics.
  3. Verify data is read in 16-bit (word) units.
  4. Set only one bit in EBR1 or EBR2. More than one bit cannot be set.
  5. Erasing is performed in block units. To erase a number of blocks, the individual blocks must be erased sequentially.

**Figure 8.13 Erase/Erase-Verify Flowchart (Single-Block Erase)**

## 8.6 Flash Memory Protection

There are three kinds of flash memory program/erase protection: hardware protection, software protection, and error protection.

### 8.6.1 Hardware Protection

Hardware protection refers to a state in which programming/erasing of flash memory is forcibly disabled or aborted. Hardware protection is reset by settings in flash memory control registers 1 and 2 (FLMCR1, FLMCR2) and erase block registers 1 and 2 (EBR1, EBR2). (See table 8.7.)

**Table 8.7 Hardware Protection**

Item	Description	Functions	
		Program	Erase
FWE pin protection	<ul style="list-style-type: none"> <li>When a low level is input to the FWE pin, FLMCR1, FLMCR2, EBR1, and EBR2 are initialized, and the program/erase-protected state is entered</li> </ul>	Yes	Yes
Reset/standby protection	<ul style="list-style-type: none"> <li>In a reset (including a WDT overflow reset) and in power-down state (excluding the medium-speed mode, module stop mode, and sleep mode), FLMCR1, FLMCR2 (excluding the FLER bit), EBR1, and EBR2 are initialized, and the program/erase-protected state is entered</li> <li>In a reset via the <math>\overline{\text{RES}}</math> pin, the reset state is not entered unless the <math>\overline{\text{RES}}</math> pin is held low until oscillation stabilizes after powering on. In the case of a reset during operation, hold the <math>\overline{\text{RES}}</math> pin low for the <math>\overline{\text{RES}}</math> pulse width specified in the AC characteristics section</li> </ul>	Yes	Yes

## 8.6.2 Software Protection

Software protection can be implemented by setting the SWE bit in FLMCR1 and erase block registers 1 and 2 (EBR1, EBR2). When software protection is in effect, setting the P1 or E1 bit in flash memory control register 1 (FLMCR1), or setting the P2 or E2 bit in flash memory control register 2 (FLMCR2) does not cause a transition to program mode or erase mode. (See table 8.8.)

**Table 8.8 Software Protection**

Item	Description	Functions	
		Program	Erase
SWE bit protection	<ul style="list-style-type: none"> <li>Clearing the SWE bit to 0 in FLMCR1 sets the program/erase-protected state for all blocks (Execute in on-chip RAM or external memory)</li> </ul>	Yes	Yes
Block specification protection	<ul style="list-style-type: none"> <li>Erase protection can be set for individual blocks by settings in erase block registers 1 and 2 (EBR1, EBR2)</li> <li>Setting EBR1 and EBR2 to H'00 places all blocks in the erase-protected state</li> </ul>	—	Yes

### 8.6.3 Error Protection

In error protection, an error is detected when MCU runaway occurs during flash memory programming/erasing, or operation is not performed in accordance with the program/erase algorithm, and the program/erase operation is aborted. Aborting the program/erase operation prevents damage to the flash memory due to overprogramming or overerasing.

If the MCU malfunctions during flash memory programming/erasing, the FLER bit is set to 1 in FLMCR2 and the error protection state is entered. The FLMCR1, FLMCR2, EBR1, and EBR2 settings are retained, but program mode or erase mode is aborted at the point at which the error occurred. Program mode or erase mode cannot be re-entered by re-setting the P1, E1, P2 or E2 bit. However, PV1, EV1, PV2, or EV2 bit setting is enabled, and a transition can be made to verify mode.

FLER bit setting conditions are as follows:

- (1) When flash memory is read during programming/erasing (including a vector read or instruction fetch)
- (2) Immediately after exception handling (excluding a reset) during programming/erasing
- (3) When a SLEEP instruction is executed during programming/erasing

Error protection is released only by a reset and in hardware standby mode.

Figure 8.14 shows the flash memory state transition diagram.

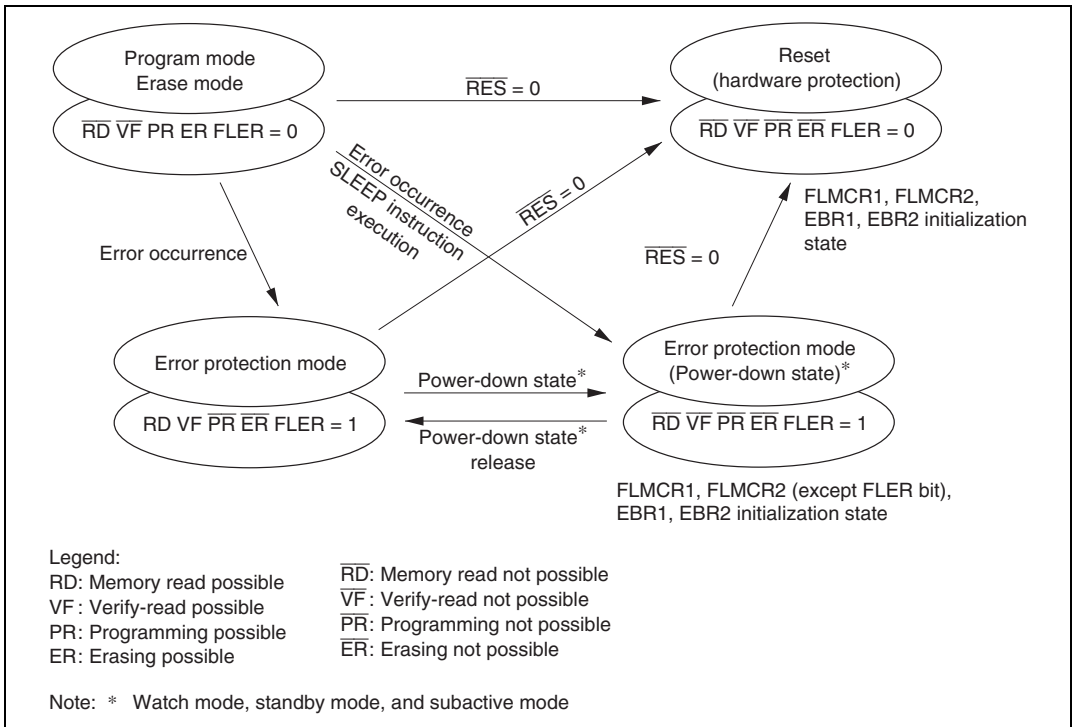


Figure 8.14 Flash Memory State Transitions

## 8.7 Interrupt Handling when Programming/Erasing Flash Memory

All interrupts, including NMI input is disabled when flash memory is being programmed or erased (when the Pn or En bit is set in FLMCRn), and while the boot program is executing in boot mode<sup>\*1</sup>, to give priority to the program or erase operation. There are three reasons for this:

- (1) Interrupt during programming or erasing might cause a violation of the programming or erasing algorithm, with the result that normal operation could not be assured.
- (2) In the interrupt exception handling sequence during programming or erasing, the vector would not be read correctly<sup>\*2</sup>, possibly resulting in MCU runaway.
- (3) If interrupt occurred during boot program execution, it would not be possible to execute the normal boot mode sequence.

For these reasons, in on-board programming mode alone there are conditions for disabling interrupt, as an exception to the general rule. However, this provision does not guarantee normal erasing and programming or MCU operation. All requests, including NMI input, must therefore be disabled inside and outside the MCU during FWE application. Interrupt is also disabled in the error-protection state while the Pn or En bit remains set in FLMCRn.

- Notes:
1. Interrupt requests must be disabled inside and outside the MCU until data write by the write control program is complete.
  2. The vector may not be read correctly in this case for the following two reasons:
    - If flash memory is read while being programmed or erased (while the Pn or En bit is set in FLMCRn), correct read data will not be obtained (undetermined values will be returned).
    - If the interrupt entry in the interrupt vector table has not been programmed yet, interrupt exception handling will not be executed correctly.



## 8.8 Flash Memory Programmer Mode

### 8.8.1 Programmer Mode Setting

Programs and data can be written and erased in programmer mode as well as in the on-board programming modes. In programmer mode, the on-chip ROM can be freely programmed using a PROM programmer that supports Renesas Technology microcomputer device type with 256-kbyte on-chip flash memory. Flash memory read mode, auto-program mode, auto-erase mode, and status read mode are supported with these device types. In auto-program mode, auto-erase mode, and status read mode, a status polling procedure is used, and in status read mode, detailed internal signals are output after execution of an auto-program or auto-erase operation.

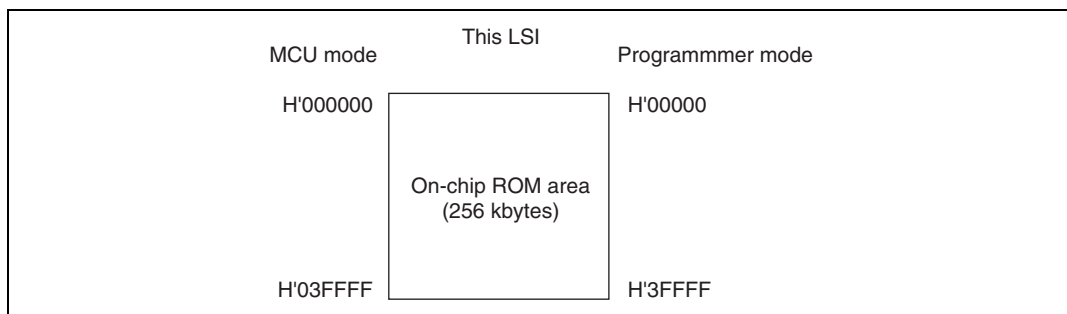
### 8.8.2 Socket Adapters and Memory Map

In programmer mode, a socket adapter is mounted on the writer programmer. The socket adapter product codes are listed in table 8.9.

Figure 8.15 shows the memory map in programmer mode.

**Table 8.9 Socket Adapter Product Codes**

Part No.	Package	Socket Adapter Product Code
HD64F2194C	112-pin QFP	ME2194ESHF1H



**Figure 8.15 Memory Map in Programmer Mode**

### 8.8.3 Programmer Mode Operation

Table 8.10 shows how the different operating modes are set when using programmer mode, and table 8.11 lists the commands used in programmer mode. Details of each mode are given below.

#### (1) Memory Read Mode

Memory read mode supports byte reads.

#### (2) Auto-Program Mode

Auto-program mode supports programming of 128 bytes at a time. Status polling is used to confirm the end of auto-programming.

#### (3) Auto-Erase Mode

Auto-erase mode supports automatic erasing of the entire flash memory. Status polling is used to confirm the end of auto-erasing.

#### (4) Status Read Mode

Status polling is used for auto-programming and auto-erasing, and normal termination can be confirmed by reading the FO6 signal. In status read mode, error information is output if an error occurs.

**Table 8.10 Settings for Each Operating Mode in Programmer Mode**

Mode	Pin Names					
	FWE	$\overline{CE}$	$\overline{OE}$	$\overline{WE}$	FO0 to FO7	FA0 to FA17
Read	H or L	L	L	H	Data output	Ain
Output disable	H or L	L	H	H	Hi-Z	X
Command write	H or L <sup>*3</sup>	L	H	L	Data input	Ain <sup>*2</sup>
Chip disable <sup>*1</sup>	H or L	H	X	X	Hi-Z	X

Notes: 1. Chip disable is not a standby state; internally, it is an operation state.

2. Ain indicates that there is also address input in auto-program mode.

3. For command writes when making a transition to auto-program or auto-erase mode, input a high level to the FWE pin.

**Table 8.11 Programmer Mode Commands**

Command Name	Number of Cycles	1st Cycle			2nd Cycle		
		Mode	Address	Data	Mode	Address	Data
Memory read mode	1 + n	write	X	H'00	read	RA	Dout
Auto-program mode	129	write	X	H'40	write	WA	Din
Auto-erase mode	2	write	X	H'20	write	X	H'20
Status read mode	2	write	X	H'71	write	X	H'71

- Notes: 1. In auto-program mode, 129 cycles are required for command writing by a simultaneous 128-byte write.
2. In memory read mode, the number of cycles depends on the number of address write cycles (n).

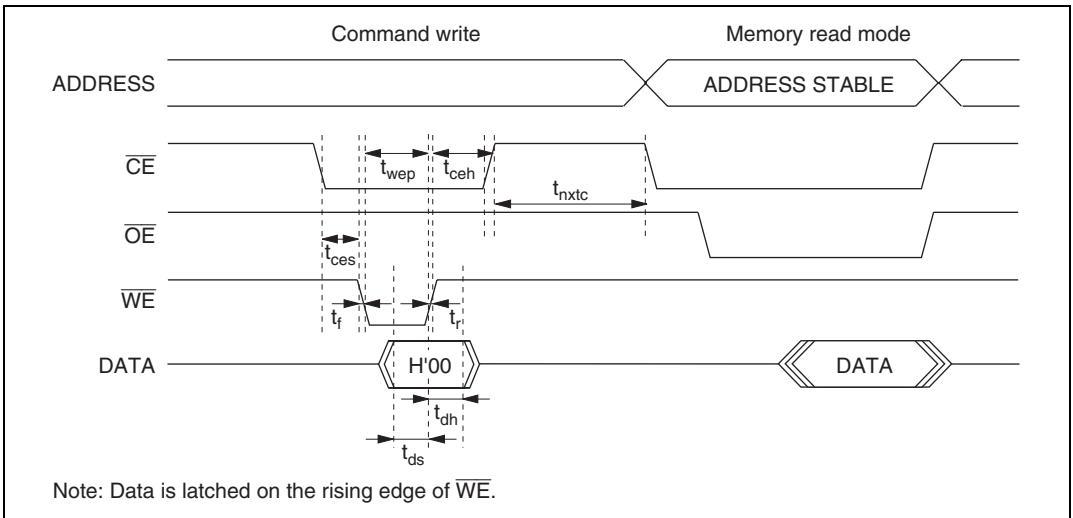
### 8.8.4 Memory Read Mode

- (1) After the end of an auto-program, auto-erase, or status read operation, the command wait state is entered. To read memory contents, a transition must be made to memory read mode by means of a command write before the read is executed.
- (2) Command writes can be performed in memory read mode, just as in the command wait state.
- (3) Once memory read mode has been entered, consecutive reads can be performed.
- (4) After power-on, memory read mode is entered.

**Table 8.12 AC Characteristics in Memory Read Mode (1)**

(Conditions:  $V_{CC} = 5.0 \text{ V} \pm 10\%$ ,  $V_{SS} = 0 \text{ V}$ ,  $T_a = 25^\circ\text{C} \pm 5^\circ\text{C}$ )

Item	Symbol	Min	Max	Unit
Command write cycle	$t_{nxtc}$	20	—	$\mu\text{s}$
$\overline{\text{CE}}$ hold time	$t_{ceh}$	0	—	ns
$\overline{\text{CE}}$ setup time	$t_{ces}$	0	—	ns
Data hold time	$t_{dh}$	50	—	ns
Data setup time	$t_{ds}$	50	—	ns
Write pulse width	$t_{wep}$	70	—	ns
$\overline{\text{WE}}$ rise time	$t_r$	—	30	ns
$\overline{\text{WE}}$ fall time	$t_f$	—	30	ns

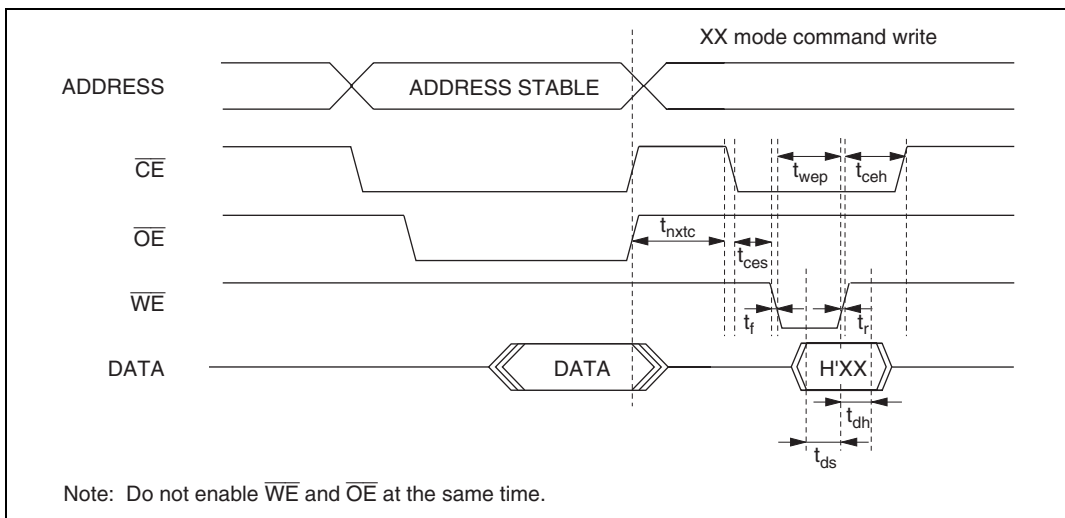


**Figure 8.16 Memory Read Mode Timing Waveforms after Command Write**

**Table 8.13 AC Characteristics when Entering Another Mode from Memory Read Mode**

(Conditions:  $V_{CC} = 5.0\text{ V} \pm 10\%$ ,  $V_{SS} = 0\text{ V}$ ,  $T_a = 25^\circ\text{C} \pm 5^\circ\text{C}$ )

Item	Symbol	Min	Max	Unit
Command write cycle	$t_{nxtc}$	20	—	$\mu\text{s}$
$\overline{CE}$ hold time	$t_{ceh}$	0	—	ns
$\overline{CE}$ setup time	$t_{ces}$	0	—	ns
Data hold time	$t_{dh}$	50	—	ns
Data setup time	$t_{ds}$	50	—	ns
Write pulse width	$t_{wep}$	70	—	ns
$\overline{WE}$ rise time	$t_r$	—	30	ns
$\overline{WE}$ fall time	$t_f$	—	30	ns



**Figure 8.17 Timing Waveforms when Entering Another Mode from Memory Read Mode**

**Table 8.14 AC Characteristics in Memory Read Mode (2)**

(Conditions:  $V_{cc} = 5.0 \text{ V} \pm 10\%$ ,  $V_{ss} = 0 \text{ V}$ ,  $T_a = 25^\circ\text{C} \pm 5^\circ\text{C}$ )

Item	Symbol	Min	Max	Unit
Access time	$t_{acc}$	—	20	$\mu\text{s}$
$\overline{CE}$ output delay time	$t_{ce}$	—	150	ns
$\overline{OE}$ output delay time	$t_{oe}$	—	150	ns
Output disable delay time	$t_{df}$	—	100	ns
Data output hold time	$t_{oh}$	5	—	ns

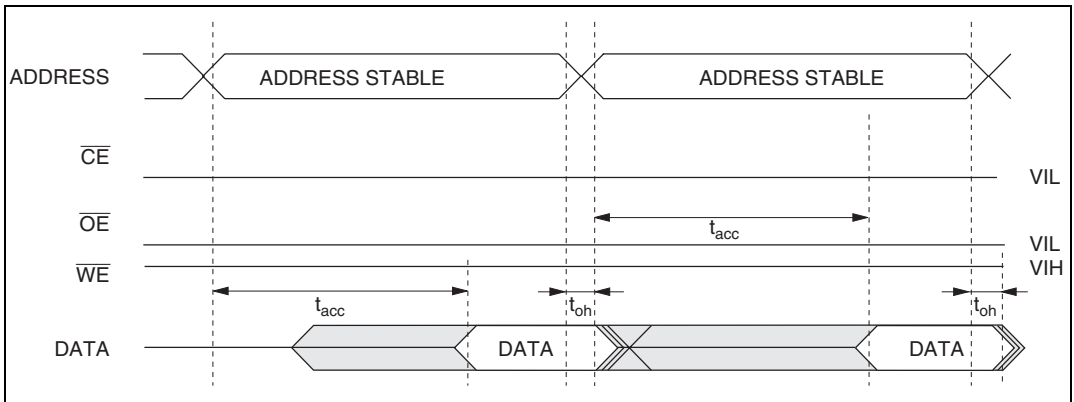


Figure 8.18 Timing Waveforms for  $\overline{CE}/\overline{OE}$  Enable State Read

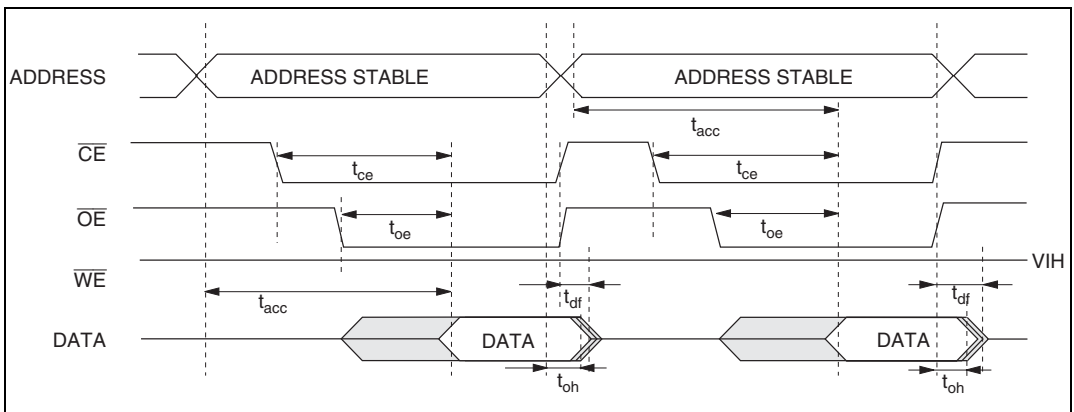


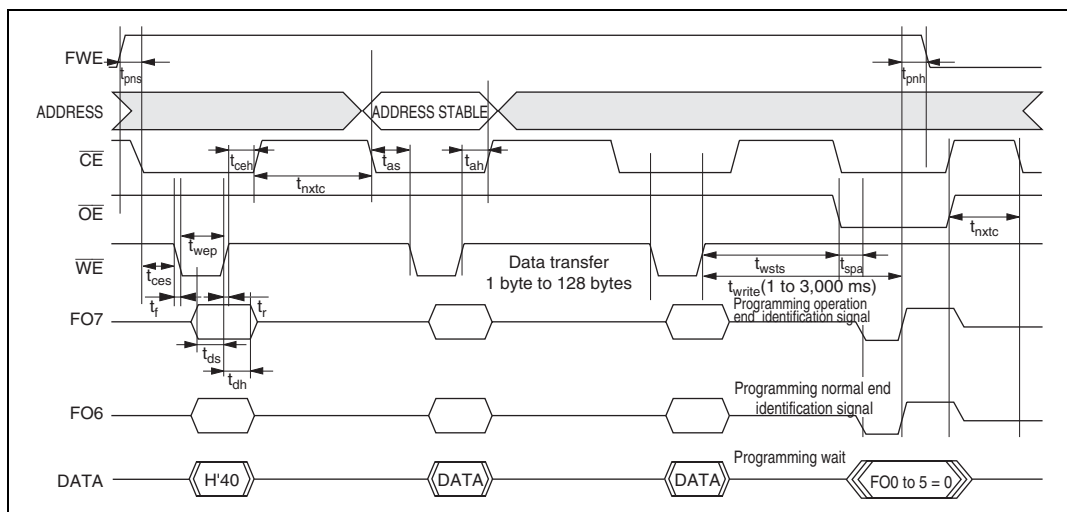
Figure 8.19 Timing Waveforms for  $\overline{CE}/\overline{OE}$  Clocked Read

### 8.8.5 Auto-Program Mode

- (a) In auto-program mode, 128 bytes are programmed simultaneously. This should be carried out by executing 128 consecutive byte transfers.
- (b) A 128-byte data transfer is necessary even when programming fewer than 128 bytes. In this case, H'FF data must be written to the extra addresses.
- (c) The lower 8 bits of the transfer address must be H'00 or H'80. If a value other than an effective address is input, processing will switch to a memory write operation but a write error will be flagged.
- (d) Memory address transfer is performed in the second cycle (figure 8.20). Do not perform transfer after the third cycle.
- (e) Do not perform a command write during a programming operation.
- (f) Perform one auto-programming operation for a 128-byte block for each address.  
Characteristics are not guaranteed for two or more programming operations.
- (g) Confirm normal end of auto-programming by checking FO6. Alternatively, status read mode can also be used for this purpose (FO7 status polling uses the auto-program operation end identification pin).
- (h) The status polling FO6 and FO7 pin information is retained until the next command write.  
Until the next command write is performed, reading is possible by enabling  $\overline{CE}$  and  $\overline{OE}$ .

**Table 8.15 AC Characteristics in Auto-Program**(Conditions:  $V_{CC} = 5.0\text{ V} \pm 10\%$ ,  $V_{SS} = 0\text{ V}$ ,  $T_a = 25^\circ\text{C} \pm 5^\circ\text{C}$ )

Item	Symbol	Min	Max	Unit
Command write cycle	$t_{nxtc}$	20	—	$\mu\text{s}$
$\overline{\text{CE}}$ hold time	$t_{ceh}$	0	—	ns
$\overline{\text{CE}}$ setup time	$t_{ces}$	0	—	ns
Data hold time	$t_{dh}$	50	—	ns
Data setup time	$t_{ds}$	50	—	ns
Write pulse width	$t_{wep}$	70	—	ns
Status polling start time	$t_{wsts}$	1	—	ms
Status polling access time	$t_{spa}$	—	150	ns
Address setup time	$t_{as}$	0	—	ns
Address hold time	$t_{ah}$	60	—	ns
Memory write time	$t_{write}$	1	3000	ms
$\overline{\text{WE}}$ rise time	$t_r$	—	30	ns
$\overline{\text{WE}}$ fall time	$t_f$	—	30	ns
Write setup time	$t_{pns}$	100	—	ns
Write end setup time	$t_{pnh}$	100	—	ns

**Figure 8.20 Auto-Program Mode Timing Waveforms**



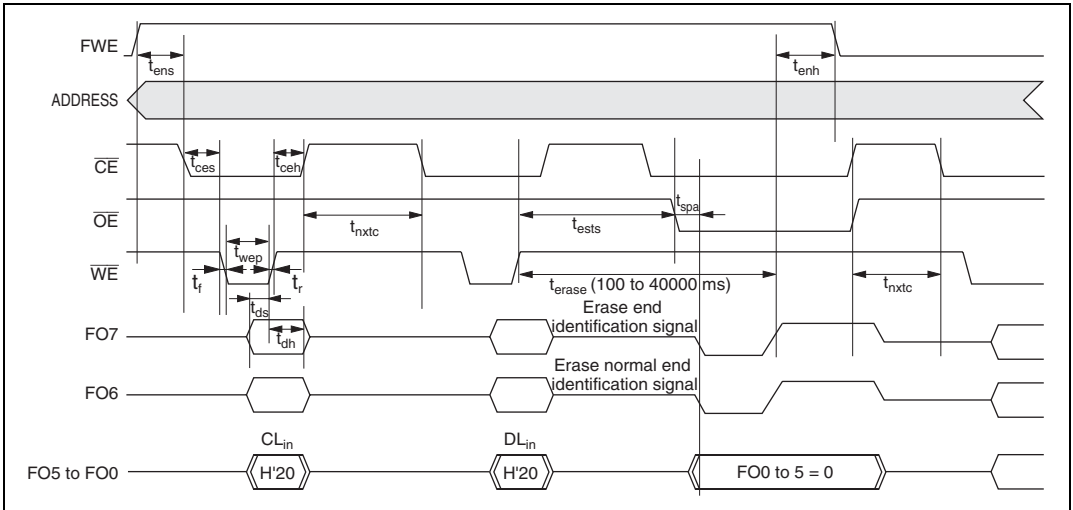
### 8.8.6 Auto-Erase Mode

- (a) Auto-erase mode supports only entire memory erasing.
- (b) Do not perform a command write during auto-erasing.
- (c) Confirm normal end of auto-erasing by checking FO6. Alternatively, status read mode can also be used for this purpose (FO7 status polling uses the auto-erase operation end identification pin).
- (d) The status polling FO6 and FO7 pin information is retained until the next command write. Until the next command write is performed, reading is possible by enabling  $\overline{\text{CE}}$  and  $\overline{\text{OE}}$ .

**Table 8.16 AC Characteristics in Auto-Erase Mode**

(Conditions:  $V_{\text{CC}} = 5.0 \text{ V} \pm 10\%$ ,  $V_{\text{SS}} = 0 \text{ V}$ ,  $T_a = 25^\circ\text{C} \pm 5^\circ\text{C}$ )

Item	Symbol	Min	Max	Unit
Command write cycle	$t_{\text{nxtc}}$	20	—	$\mu\text{s}$
$\overline{\text{CE}}$ hold time	$t_{\text{ceh}}$	0	—	ns
$\overline{\text{CE}}$ setup time	$t_{\text{ces}}$	0	—	ns
Data hold time	$t_{\text{dh}}$	50	—	ns
Data setup time	$t_{\text{ds}}$	50	—	ns
Write pulse width	$t_{\text{wep}}$	70	—	ns
Status polling start time	$t_{\text{ests}}$	1	—	ms
Status polling access time	$t_{\text{spa}}$	—	150	ns
Memory erase time	$t_{\text{erase}}$	100	40000	ms
$\overline{\text{WE}}$ rise time	$t_{\text{r}}$	—	30	ns
$\overline{\text{WE}}$ fall time	$t_{\text{f}}$	—	30	ns
Erase setup time	$t_{\text{ens}}$	100	—	ns
Erase end setup time	$t_{\text{enh}}$	100	—	ns



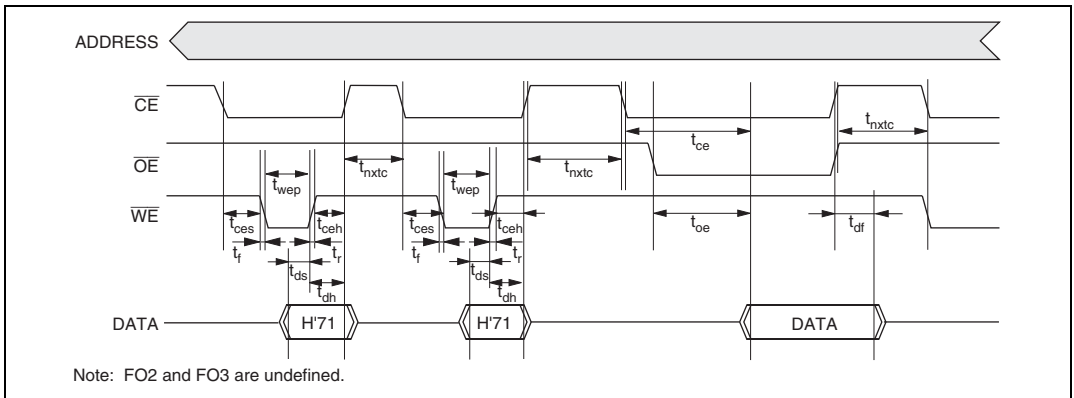
**Figure 8.21 Auto-Erase Mode Timing Waveforms**

### 8.8.7 Status Read Mode

- (1) Status read mode is used to identify what type of abnormal end has occurred. Use this mode when an abnormal end occurs in auto-program mode or auto-erase mode.
- (2) The return code is retained until a command write for other than status read mode is performed.

**Table 8.17 AC Characteristics in Status Read Mode**(Conditions:  $V_{CC} = 5.0\text{ V} \pm 10\%$ ,  $V_{SS} = 0\text{ V}$ ,  $T_a = 25^\circ\text{C} \pm 5^\circ\text{C}$ )

Item	Symbol	Min	Max	Unit
Command write cycle	$t_{nxtc}$	20	—	$\mu\text{s}$
$\overline{\text{CE}}$ hold time	$t_{ceh}$	0	—	ns
$\overline{\text{CE}}$ setup time	$t_{ces}$	0	—	ns
Data hold time	$t_{dh}$	50	—	ns
Data setup time	$t_{ds}$	50	—	ns
Write pulse width	$t_{wep}$	70	—	ns
$\overline{\text{OE}}$ output delay time	$t_{oe}$	—	150	ns
Disable delay time	$t_{df}$	—	100	ns
$\overline{\text{CE}}$ output delay time	$t_{ce}$	—	150	ns
$\overline{\text{WE}}$ rise time	$t_r$	—	30	ns
$\overline{\text{WE}}$ fall time	$t_f$	—	30	ns

**Figure 8.22 Status Read Mode Timing Waveforms**

**Table 8.18 Status Read Mode Return Commands**

Pin Name	FO7	FO6	FO5	FO4	FO3	FO2	FO1	FO0
Attribute	Normal end identifica- tion	Command error	Program- ming error	Erase error	—	—	Program- ming or erase count exceeded	Effective address error
Initial value	0	0	0	0	0	0	0	0
Indica- tions	Normal end: 0 Abnormal end: 1	Command error: 1 Otherwise: 0 <sup>1</sup>	Program- ming error: 0 <sup>1</sup> Otherwise: 0	Erase error: 1 Otherwise: 0	—	—	Count exceeded: 1 Otherwise: 0	Effective address error: 1 Otherwise: 0

Note: FO2 and FO3 are undefined.

### 8.8.8 Status Polling

- (1) The FO7 status polling flag indicates the operating status in auto-program or auto-erase mode.
- (2) The FO6 status polling flag indicates a normal or abnormal end in auto-program or auto-erase mode.

**Table 8.19 Status Polling Output Truth Table**

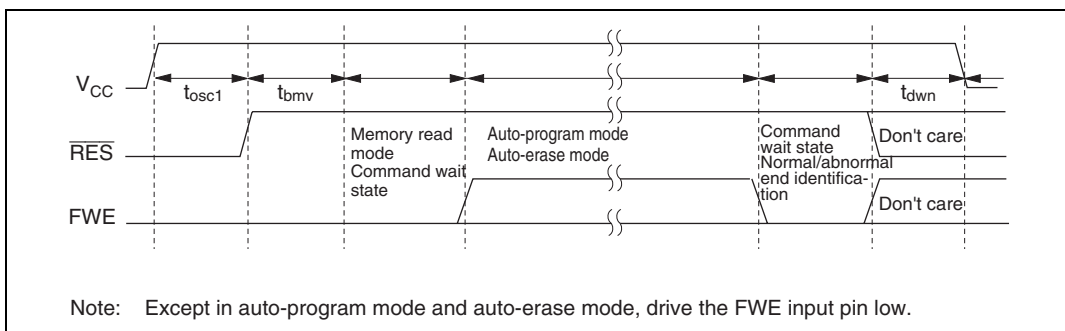
Pin Names	Internal Operation in			Normal End
	Progress	Abnormal End	—	
FO7	0	1	0	1
FO6	0	0	1	1
FO0 to FO5	0	0	0	0

### 8.8.9 Programmer Mode Transition Time

Commands cannot be accepted during the oscillation stabilization period or the programmer mode setup period. After the programmer mode setup time, a transition is made to memory read mode.

**Table 8.20 Command Wait State Transition Time Specifications**

Item	Symbol	Min	Max	Unit
Standby release (oscillation stabilization time)	$t_{osc1}$	10	—	ms
Programmer mode setup time	$t_{bmV}$	10	—	ms
$V_{CC}$ hold time	$t_{dwn}$	0	—	ms



**Figure 8.23 Oscillation Stabilization Time, Boot Program Transfer Time, and Power Supply Fall Sequence**

### 8.8.10 Notes On Memory Programming

- (1) When programming addresses which have previously been programmed, carry out auto-erasing before auto-programming.
- (2) When performing programming using programmer mode on a chip that has been programmed/erased in an on-board programming mode, auto-erasing is recommended before carrying out auto-programming.

Notes: 1. The flash memory is initially in the erased state when the device is shipped by Renesas. For other chips for which the erasure history is unknown, it is recommended that auto-erasing be executed to check and supplement the initialization (erase) level.

2. Auto-programming should be performed once only on the same address block.

## 8.9 Flash Memory Programming and Erasing Precautions

Precautions concerning the use of on-board programming mode and programmer mode are summarized below.

(1) Use the specified voltages and timing for programming and erasing

Applied voltages in excess of the rating can permanently damage the device. Use a PROM programmer that supports Renesas Technology microcomputer device type with 256-kbyte on-chip flash memory.

Do not select the HN28F101 setting for the PROM programmer, and only use the specified socket adapter. Incorrect use will result in damaging the device.

(2) Powering on and off

Do not apply a high level to the FWE pin until  $V_{CC}$  has stabilized. Also, drive the FWE pin low before turning off  $V_{CC}$ .

When applying or disconnecting  $V_{CC}$ , fix the FWE pin low and place the flash memory in the hardware protection state.

The power-on and power-off timing requirements should also be satisfied in the event of a power failure and subsequent recovery.

(3) FWE application/disconnection

FWE application should be carried out when MCU operation is in a stable condition. If MCU operation is not stable, fix the FWE pin low and set the protection state.

The following points must be observed concerning FWE application and disconnection to prevent unintentional programming or erasing of flash memory:

(a) Apply FWE when the  $V_{CC}$  voltage has stabilized within its rated voltage range.

(b) In boot mode, apply and disconnect FWE during a reset.

(c) In user program mode, FWE can be switched between high and low level regardless of the reset state. FWE input can also be switched during program execution in flash memory.

(d) Do not apply FWE if program runaway has occurred.

(e) Disconnect FWE only when the SWE, ESU1, ESU2, PSU1, PSU2, EV1, EV2, PV1, PV2, P1, P2, E1, and E2 bits in FLMCR1 and FLMCR2 are cleared.

Make sure that the SWE, ESU1, ESU2, PSU1, PSU2, EV1, EV2, PV1, PV2, P1, P2, E1, and E2 bits are not set by mistake when applying or disconnecting FWE.

(4) Do not apply a constant high level to the FWE pin

Apply a high level to the FWE pin only when programming or erasing flash memory. A system configuration in which a high level is constantly applied to the FWE should be avoided. Also, while a high level is applied to the FWE pin, the watchdog timer should be activated to prevent overprogramming or overerasing due to program runaway, etc.

- (5) Use the recommended algorithm when programming and erasing flash memory  
The recommended algorithm enables programming and erasing to be carried out without subjecting the device to voltage stress or sacrificing program data reliability. When setting the Pn or En bit in FLMCR1 and FLMCR2, the watchdog timer should be set beforehand as a precaution against program runaway, etc.
- (6) Do not set or clear the SWE bit during program execution in flash memory  
Clear the SWE bit before executing a program or reading data in flash memory.  
When the SWE bit is set, data in flash memory can be rewritten, but flash memory should only be accessed for verify operations (verification during programming/erasing).
- (7) Do not use interrupts while flash memory is being programmed or erased  
All interrupt requests, including NMI, should be disabled during FWE application to give priority to program/erase operations.
- (8) Do not perform additional programming. Erase the memory before reprogramming.  
In on-board programming, perform only one programming operation on a 32-byte programming unit block. In programmer mode, too, perform only one programming operation on a 128-byte programming unit block. Programming should be carried out with the entire programming unit block erased.
- (9) Before programming, check that the chip is correctly mounted in the PROM programmer.  
Overcurrent damage to the device can result if the index marks on the PROM programmer socket, socket adapter, and chip are not correctly aligned.
- (10) Do not touch the socket adapter or chip during programming.  
Touching either of these can cause contact faults and write errors.

## 8.10 Note on Switching from F-ZTAT Version to Mask ROM Version

The mask ROM version does not have the internal registers for flash memory control that are provided in the F-ZTAT version. Table 8.21 lists the registers that are present in the F-ZTAT version but not in the mask ROM version. If a register listed in table 8.21 is read in the mask ROM version, an undefined value will be returned. Therefore, if application software developed on the F-ZTAT version is switched to a mask ROM version product, it must be modified to ensure that the registers in table 8.21 have no effect.

**Table 8.21 Registers Present in F-ZTAT Version but Absent in Mask ROM Version**

<b>Register</b>	<b>Abbreviation</b>	<b>Address</b>
Flash memory control register 1	FLMCR1	H'FFF8
Flash memory control register 2	FLMCR2	H'FFF9
Erase block register 1	EBR1	H'FFFA
Erase block register 2	EBR2	H'FFFB



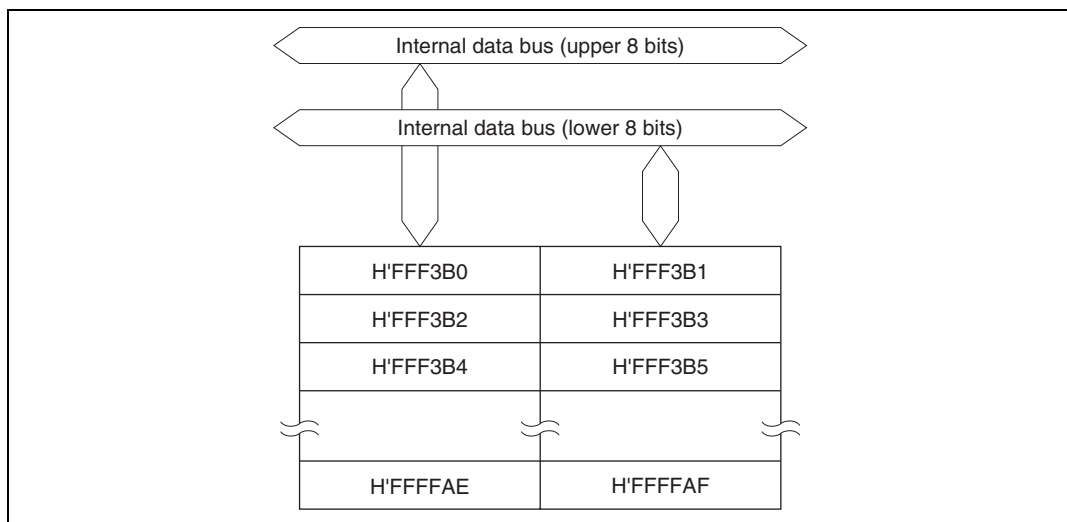
## Section 9 RAM

### 9.1 Overview

The H8S/2194C, H8S/2194B, and H8S/2194A have 6 kbytes, and the H8S/2194, H8S/2193, H8S/2192, and H8S/2191 have 3 kbytes, of on-chip high-speed static RAM. The on-chip RAM is connected to the CPU by a 16-bit data bus, enabling both byte data and word data to be accessed in one state. This makes it possible to perform fast word data transfer.

#### 9.1.1 Block Diagram

Figure 9.1 shows a block diagram of the on-chip RAM.



**Figure 9.1 Block Diagram of RAM (H8S/2194)**



## Section 10 Clock Pulse Generator

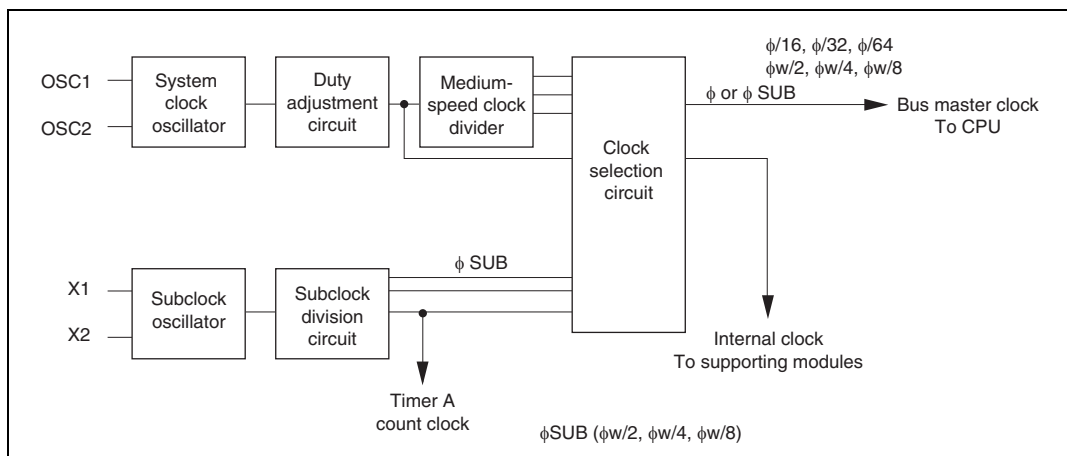
### 10.1 Overview

This LSI has a built-in clock pulse generator (CPG) that generates the system clock ( $\phi$ ), the bus master clock, and internal clocks.

The clock pulse generator consists of a system clock oscillator, a duty adjustment circuit, clock selection circuit, medium-speed clock divider, subclock oscillator, and subclock division circuit.

#### 10.1.1 Block Diagram

Figure 10.1 shows a block diagram of the clock pulse generator.



**Figure 10.1 Block Diagram of Clock Pulse Generator**

#### 10.1.2 Register Configuration

The clock pulse generator is controlled by SBYCR and LPWRCR. Table 10.1 shows the register configuration.

**Table 10.1 CPG Registers**

Name	Abbreviation	R/W	Initial Value	Address*
Standby control register	SBYCR	R/W	H'00	H'FFEA
Low-power control register	LPWRCR	R/W	H'00	H'FFEB

Note: \* Lower 16 bits of the address.

## 10.2 Register Descriptions

### 10.2.1 Standby Control Register (SBYCR)

Bit:	7	6	5	4	3	2	1	0
	SSBY	STS2	STS1	STS0	—	—	SCK1	SCK0
Initial value:	0	0	0	0	0	0	0	0
R/W:	R/W	R/W	R/W	R/W	—	—	R/W	R/W

SBYCR is an 8-bit readable/writable register that performs power-down mode control.

Only bits 0 and 1 are described here. For a description of the other bits, see section 4.2.1, Standby Control Register (SBYCR). SBYCR is initialized to H'00 by a reset.

**Bits 1 and 0—System Clock Select 1 and 0 (SCK1, SCK0):** These bits select the bus master clock for high-speed mode and medium-speed mode.

Bit 1	Bit 0	Description
SCK1	SCK0	
0	0	Bus master is in high-speed mode (Initial value)
	1	Medium-speed clock is $\phi/16$
1	0	Medium-speed clock is $\phi/32$
	1	Medium-speed clock is $\phi/64$

## 10.2.2 Low-Power Control Register (LPWRCCR)

Bit:	7	6	5	4	3	2	1	0
	DTON	LSON	NESEL	—	—	—	SA1	SA0
Initial value:	0	0	0	0	0	0	0	0
R/W:	R/W	R/W	R/W	—	—	—	R/W	R/W

LPWRCCR is an 8-bit readable/writable register that performs power-down mode control.

Only bit 1 and 0 is described here. For a description of the other bits, see section 4.2.2, Low-Power Control Register (LPWRCCR).

LPWRCCR is initialized to H'00 by a reset.

**Bits 1 and 0—Subactive Mode Clock Select (SA1, SA0):** Selects CPU clock for subactive mode.

In subactive mode, writes are disabled.

Bit 1	Bit 0	Description
SA1	SA0	
0	0	CPU operating clock is $\phi_w/8$ (Initial value)
	1	CPU operating clock is $\phi_w/4$
1	*	CPU operating clock is $\phi_w/2$

Legend: \* Don't care

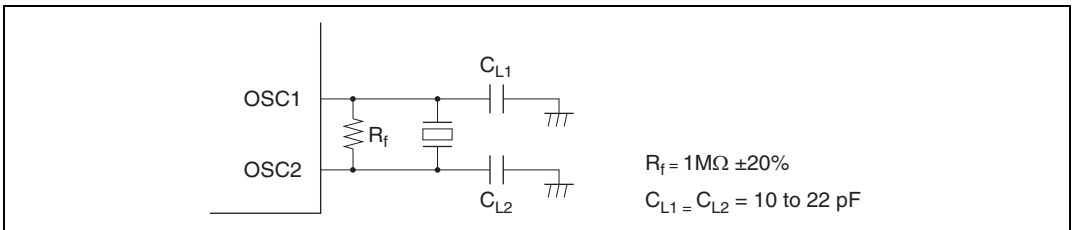
## 10.3 Oscillator

Clock pulses can be supplied by connecting a crystal resonator, or by input of an external clock.

### 10.3.1 Connecting a Crystal Resonator

#### (1) Circuit Configuration

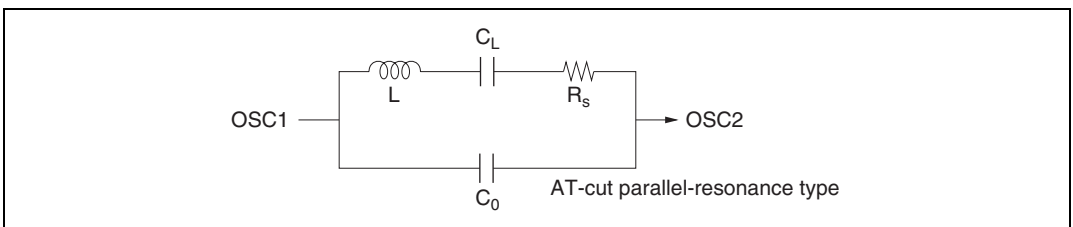
A crystal resonator can be connected as shown in the example in figure 10.2. An AT-cut parallel-resonance crystal should be used.



**Figure 10.2 Connection of Crystal Resonator (Example)**

#### (2) Crystal Resonator

Figure 10.3 shows the equivalent circuit of the crystal resonator. Use a crystal resonator that has the characteristics shown in table 10.2 and the same frequency as the system clock ( $\phi$ ).



**Figure 10.3 Crystal Resonator Equivalent Circuit**

**Table 10.2 Crystal Resonator Parameters**

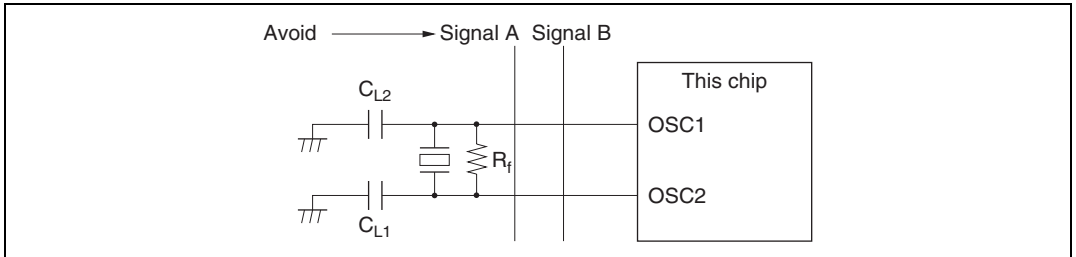
Frequency (MHz)	8	10
$R_s$ max ( $\Omega$ )	80	60
$C_o$ max (pF)	7	7

## (3) Note on Board Design

When a crystal resonator is connected, the following points should be noted.

Other signal lines should be routed away from the oscillator circuit to prevent induction from interfering with correct oscillation. See figure 10.4.

When designing the board, place the crystal resonator and its load capacitors as close as possible to the OSC1 and OSC2 pins.



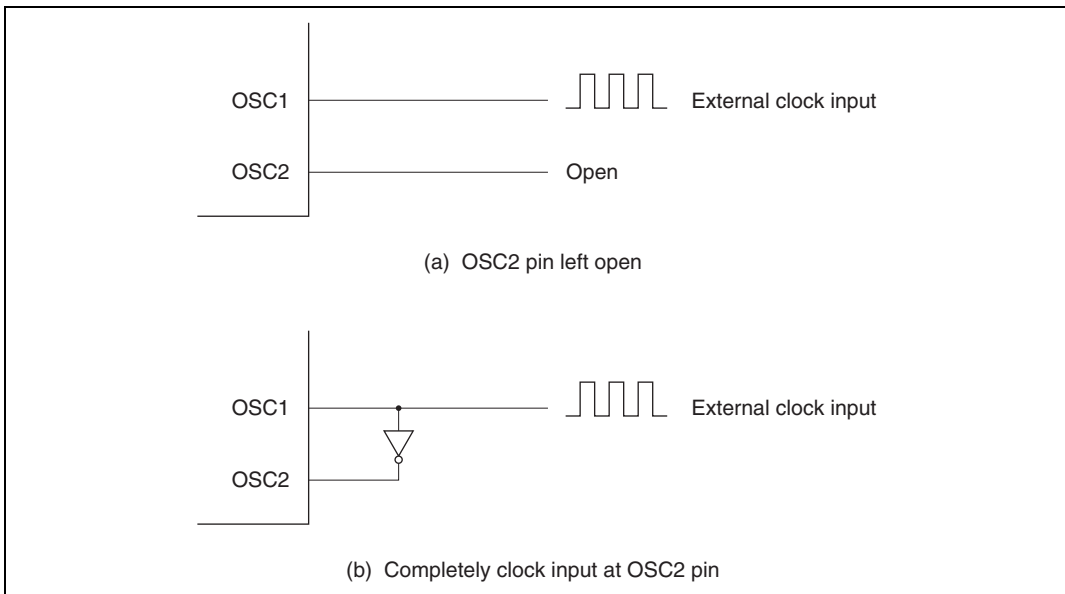
**Figure 10.4 Example of Incorrect Board Design**

### 10.3.2 External Clock Input

#### (1) Circuit Configuration

An external clock signal can be input as shown in the examples in figure 10.5. If the OSC2 pin is left open, make sure that stray capacitance is no more than 10 pF.

In example (b), make sure that the external clock is held high in standby mode, subactive mode, subsleep mode, and watch mode.



**Figure 10.5 External Clock Input (Examples)**

#### (2) External Clock

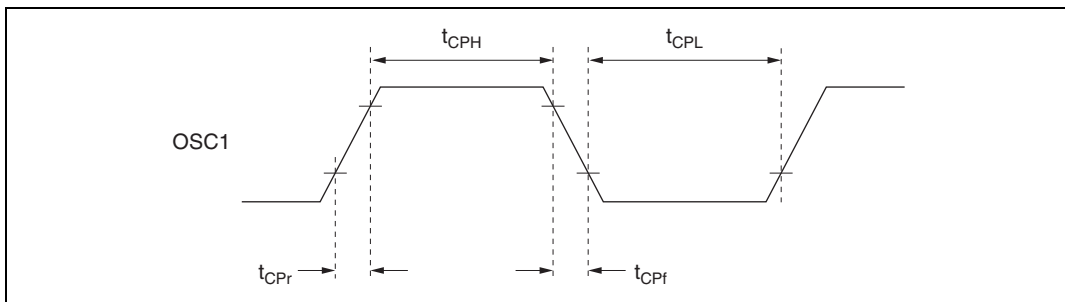
The external clock signal should have the same frequency as the system clock ( $\phi$ ).

Table 10.3 and figure 10.6 show the input conditions for the external clock.

**Table 10.3 External Clock Input Conditions**

Item	Symbol	$V_{CC} = 4.0 \text{ to } 5.5 \text{ V}$			Test Conditions
		Min	Max	Unit	
External clock input low pulse width	$t_{CPL}$	40	—	ns	Figure 10.6
External clock input high pulse width	$t_{CPH}$	40	—	ns	
External clock rise time	$t_{CPr}$	—	10	ns	
External clock fall time	$t_{CpF}$	—	10	ns	





**Figure 10.6 External Clock Input Timing**

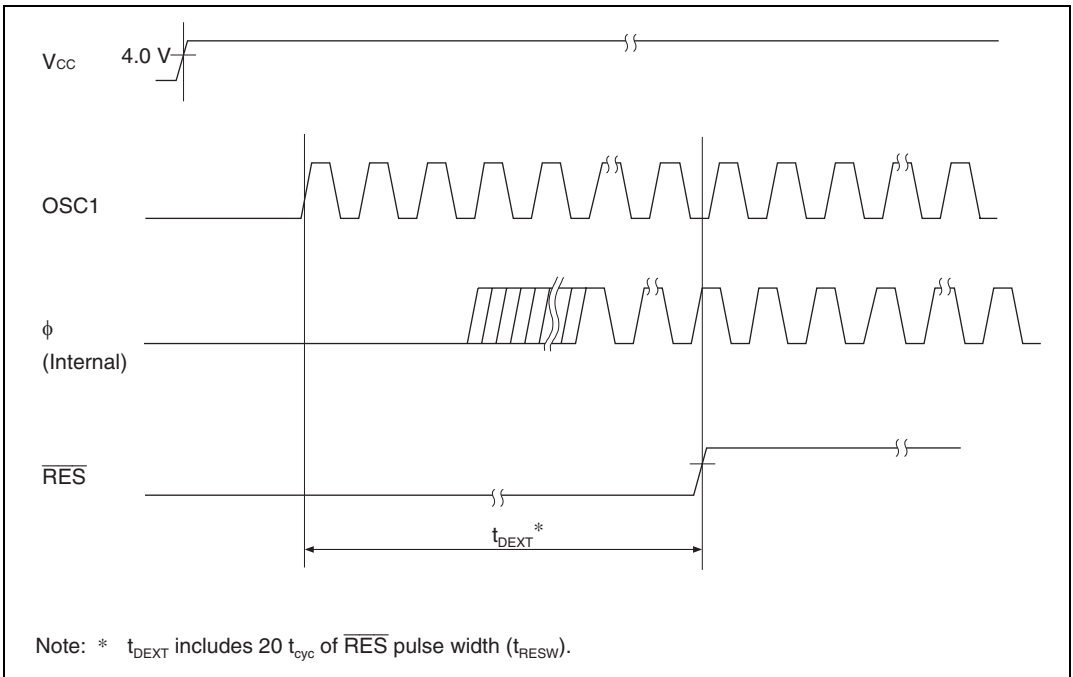
Table 10.4 shows the external clock output settling delay time, and figure 10.7 shows the external clock output settling delay timing. The oscillator and duty adjustment circuit have a function for adjusting the waveform of the external clock input at the OSC1 pin. When the prescribed clock signal is input at the OSC1 pin, internal clock signal output is fixed after the elapse of the external clock output settling delay time ( $t_{\text{DEXT}}$ ). As the clock signal output is not fixed during the  $t_{\text{DEXT}}$  period, the reset signal should be driven low to maintain the reset state.

**Table 10.4 External Clock Output Settling Delay Time**

(Conditions:  $V_{\text{CC}} = 4.0 \text{ V}$  to  $5.5 \text{ V}$ ,  $AV_{\text{CC}} = 4.0 \text{ V}$  to  $5.5 \text{ V}$ ,  $V_{\text{SS}} = AV_{\text{SS}} = 0 \text{ V}$ )

Item	Symbol	Min	Max	Unit	Notes
External clock output settling delay time	$t_{\text{DEXT}}^*$	500	—	$\mu\text{s}$	Figure 10.7

Note: \*  $t_{\text{DEXT}}$  includes  $20 t_{\text{CYC}}$  of  $\overline{\text{RES}}$  pulse width ( $t_{\text{RESW}}$ ).



**Figure 10.7 External Clock Output Settling Delay Timing**

## 10.4 Duty Adjustment Circuit

When the oscillator frequency is 5 MHz or higher, the duty adjustment circuit adjusts the duty cycle of the clock signal from the oscillator to generate the system clock ( $\phi$ ).

## 10.5 Medium-Speed Clock Divider

The medium-speed divider divides the system clock to generate  $\phi/16$ ,  $\phi/32$ , and  $\phi/64$  clocks.

## 10.6 Bus Master Clock Selection Circuit

The bus master clock selection circuit selects the system clock ( $\phi$ ) or one of the medium-speed clocks ( $\phi/16$ ,  $\phi/32$  or  $\phi/64$ ) to be supplied to the bus master (CPU), according to the settings of bits SCK2 to SCK0 in SBYCR.

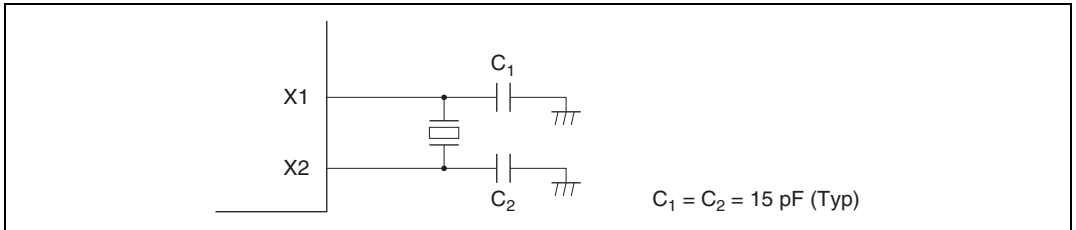
## 10.7 Subclock Oscillator Circuit

### 10.7.1 Connecting 32.768 kHz Crystal Resonator

When using a subclock, connect a 32.768 kHz crystal resonator to X1 and X2 pins as shown in figure 10.8.

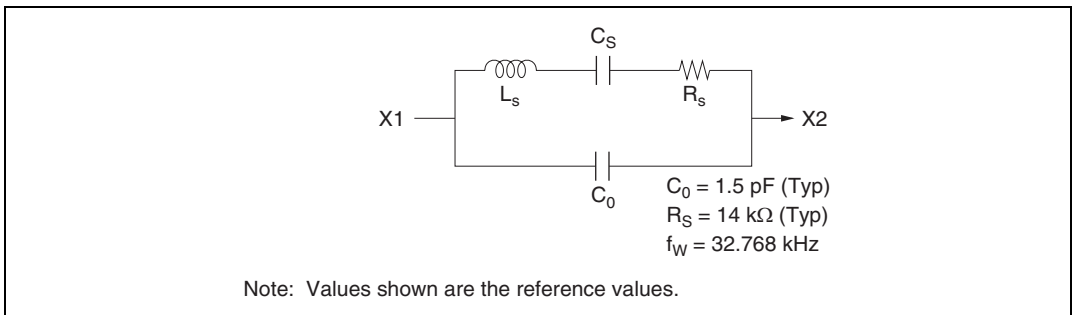
For precautions on connecting, see section 10.3.1 (3), Note on Board Design.

The subclock input conditions are shown in figure 10.10.



**Figure 10.8 Connecting a 32.768 kHz Crystal Resonator (Example)**

Figure 10.9 shows a crystal resonator equivalent circuit.

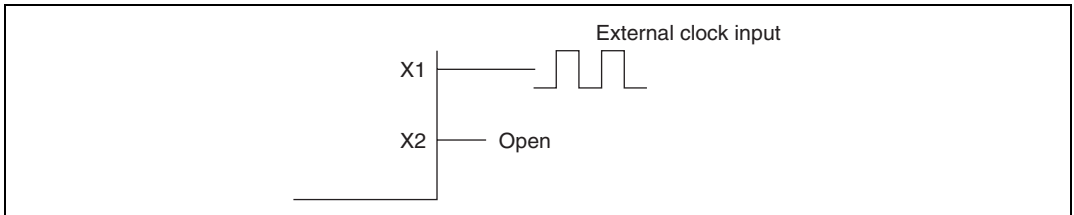


**Figure 10.9 32.768 kHz Crystal Resonator Equivalent Circuit**

### 10.7.2 External Clock Input

#### (1) Circuit Configuration

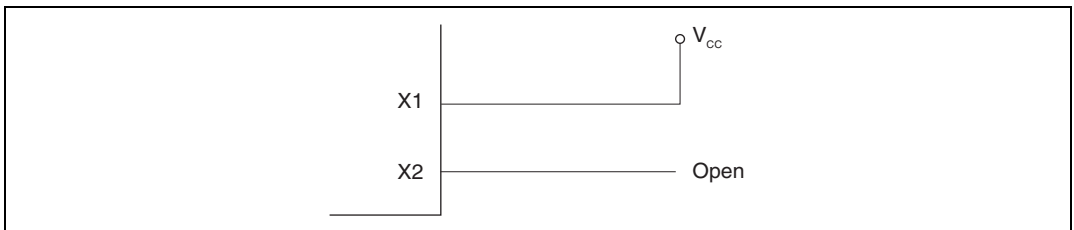
When external clock input connect to the X1 pin, and X2 pin should remain open as connection example of figure 10.10.



**Figure 10.10 Connection Example when Inputting External Clock**

### 10.7.3 When Subclock Is Not Needed

Connect X1 pin to  $V_{cc}$ , and X2 pin should remain open as shown in figure 10.11.



**Figure 10.11 Terminal When Subclock Is Not Needed**

## 10.8 Subclock Waveform Shaping Circuit

To eliminate noise in the subclock input from the X1 pin, this circuit samples the clock using a clock obtained by dividing the  $\phi$  clock. The sampling frequency is set with the NESEL bit in LPWRCR. For details, see section 4.2.2, Low-Power Control Register (LPWRCR). The clock is not sampled in subactive mode, subsleep mode, or watch mode.

## 10.9 Notes on the Resonator

Resonator characteristics are closely related to the user board design. Perform appropriate assessment of resonator connection, mask version and F-ZTAT, by referring to the connection example given in this section. The resonator circuit rate differs depending on the free capacity of the resonator and the execution circuit, so consult with the resonator manufacturer before determination. Make sure the voltage applied to the resonator pin does not exceed the maximum rated voltage.



## Section 11 I/O Port

### 11.1 Overview

#### 11.1.1 Port Functions

This LSI has seven 8-bit I/O ports (including one CMOS high-current port), one 4-bit I/O port, and one 8-bit input port. Table 11.1 shows the functions of each port. Each I/O port has a port control register (PCR) that controls an input and output and a port data register (PDR) for storing output data. The input and output can be controlled in a unit of bit. The pin whose peripheral function is used both as an alternative function can set the pin function in a unit of bit by a port mode register (PMR).

#### 11.1.2 Port Input

- Reading a Port
  - When a general port of PCR = 0 (input) is read, the pin level is read.
  - When a general port of PCR = 1 (output) is read, the value of the corresponding PDR bit is read.
  - When the pins (excluding AN7 to AN0 and RP7 to RP0 pins) set to the peripheral function are read, the results are as given in items (1) and (2) according to the PCR value.

- Processing Input Pins

The general input port or general I/O port is gated by read signals. Unused pins can be left open if they are not read. However, if an open pin is read, a feedthrough current may apply during the read period according to an intermediate level. The read period is about one-state. Relevant ports: P0, P1, P2, P3, P4, P5, P6, P7, P8

When an alternative pin is set to an alternative function other than the general I/O, always set the pin level to a high or low level. If the pin is left open, a feedthrough current applies according to an intermediate level, which adversely affects reliability, causes malfunctions, and in the worst case may damage the pin.

Because the PMR is not initialized in low power consumption mode, pay attention to the pin input level after the mode has been shifted to the low power consumption mode.

Relevant pins:  $\overline{IC}$ ,  $\overline{IRQ0}$  to  $\overline{IRQ5}$ , SCK1, SCK2, SI1, SI2,  $\overline{CS}$ , FTIA, FTIB, FTIC, FTID, TRIG, TMBI,  $\overline{ADTRG}$ , EXCAP, EXTTRG

Table 11.1 Port Functions

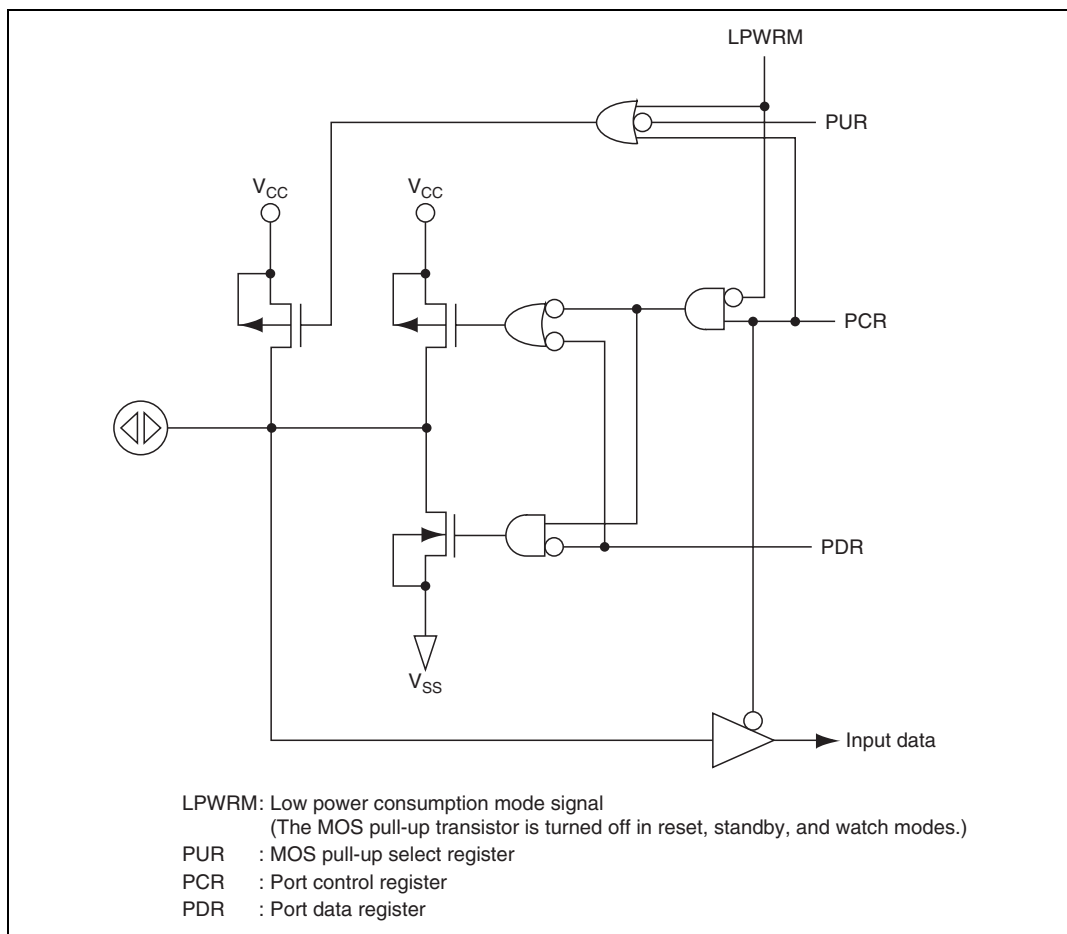
Port	Description	Pins	Alternative Functions	Function Switching Register
Port 0	P07 to P00 input-only ports	P07/AN7 to P00/AN0	Analog data input channels 7 to 0	PMR0
Port 1	P17 to P10 I/O ports (Built-in MOS pull-up transistors)	P17/TMOW	Prescaler unit frequency division clock output	PMR1
		P16/ $\overline{IC}$	Prescaler unit input capture input	
		P15/IRQ5 to P10/IRQ0	External interrupt request input	
Port 2	P27 to P20 I/O ports (Built-in MOS pull-up transistors)	P27/SCK2	SCI2 clock I/O	PMR2
		P26/SO2	SCI2 transmit data output	
		P25/SI2	SCI2 receive data input	
		P24/SCL	I <sup>2</sup> C bus interface clock I/O	ICCR
		P23/SDA	I <sup>2</sup> C bus interface data I/O	
		P22/SCK1	SCI1 clock I/O	SMR
		P21/SO1	SCI1 transmit data output	SCR
Port 3	P37 to P30 I/O ports (Built-in MOS pull-up transistors)	P37/TMO	Timer J timer output	PMR3
		P36/BUZZ	Timer J buzzer output	
		P35/PWM3 to P32/PWM0	8-bit PWM output	
		P31/STRB	SCI2 strobe output	
		P30/ $\overline{CS}$	SCI2 chip select input	
Port 4	P47 to P40 I/O ports	P47	None	—
		P46/FTOB	Timer X output compare B output	TOCR
		P45/FTOA	Timer X output compare A output	
		P44/FTID	Timer X input capture D input	—
		P43/FTIC	Timer X input capture C input	
		P42/FTIB	Timer X input capture B input	
		P41/FTIA	Timer X input capture A input	
Port 5	P53 to P50 I/O ports	P40/PWM14	14-bit PWM output	PMR4
		P53/TRIG	Realtime output port trigger input	PMR5
		P52/TMBI	Timer B event input	
		P51	None	—
Port 6	P67 to P60 I/O ports	P50/ADTRG	A/D conversion start external trigger input	ADTSR
		P67/FP7 to P60/FP0	Realtime output port	PMR6
Port 7	P77 to P70 I/O ports	P77/PPG7 to P70/PPG0	PPG output	PMR7
Port 8	P87 to P80 I/O ports (High-current ports)	P87 to P84	None	—
		P83/SV2	Servo monitor output	PMR8
		P82/SV1		
		P81/EXCAP	Capstan external synchronous signal input	
		P80/EXTTRG	External trigger signal input	



### 11.1.3 MOS Pull-Up Transistors

The MOS pull-up transistors in ports 1 to 3 can be switched on or off by the MOS pull-up select registers 1 to 3 (PUR1 to PUR3) in units of bits. Settings in PUR1 to PUR3 are valid when the pin function is set to an input by PCR1 to PCR3. If the pin function is set to an output, the MOS pull-up transistor is turned off. Figure 11.1 shows the circuit configuration of a pin with a MOS pull-up transistor.

When the pin whose peripheral function is used both as an alternative function is set to the alternative output function, the MOS pull-up transistor is turned off. When the pin is set to the alternative input function, the MOS pull-up transistor is controlled according to the PUR setting regardless of PCR.



**Figure 11.1 Circuit Configuration of Pin with MOS Pull-Up Transistor**

## 11.2 Port 0

### 11.2.1 Overview

Port 0 is an 8-bit input-only port. Table 11.2 shows the port 0 configuration.

Port 0 consists of pins that are used both as standard input ports (P07 to P00) and analog input channels (AN7 to AN0). It is switched by port mode register 0 (PMR0).

**Table 11.2 Port 0 Configuration**

Port	Function	Alternative Function
Port 0	P07 (standard input port)	AN7 (analog input channel)
	P06 (standard input port)	AN6 (analog input channel)
	P05 (standard input port)	AN5 (analog input channel)
	P04 (standard input port)	AN4 (analog input channel)
	P03 (standard input port)	AN3 (analog input channel)
	P02 (standard input port)	AN2 (analog input channel)
	P01 (standard input port)	AN1 (analog input channel)
	P00 (standard input port)	AN0 (analog input channel)

### 11.2.2 Register Configuration

Table 11.3 shows the port 0 register configuration.

**Table 11.3 Port 0 Register Configuration**

Name	Abbrev.	R/W	Size	Initial Value	Address*
Port mode register 0	PMR0	R/W	Byte	H'00	H'FFCD
Port data register 0	PDR0	R	Byte	—	H'FFC0

Note: \* Lower 16 bits of the address.

**(1) Port Mode Register 0 (PMR0)**

Bit :	7	6	5	4	3	2	1	0
	PMR07	PMR06	PMR05	PMR04	PMR03	PMR02	PMR01	PMR00
Initial value :	0	0	0	0	0	0	0	0
R/W :	R/W	R/W	R/W	R/W	R/W	R/W	R/W	R/W

Port mode register 0 (PMR0) controls switching of each pin function of port 0. The switching is specified in a unit of bit.

PMR0 is an 8-bit read/write enable register. When reset, PMR0 is initialized to H'00.

**Bits 7 to 0—P07/AN7 to P00/AN0 Pin Switching (PMR07 to PMR00):** PMR07 to PMR00 sets whether the P0n/ANn pin is used as a P0n input pin or an ANn pin for the analog input channel of an A/D converter.

**Bit n**

PMR0n	Description
0	The P0n/ANn pin functions as a P0n input pin (Initial value)
1	The P0n/ANn pin functions as an ANn input pin

Note: n = 7 to 0

**(2) Port Data Register 0 (PDR0)**

Bit :	7	6	5	4	3	2	1	0
	PDR07	PDR06	PDR05	PDR04	PDR03	PDR02	PDR01	PDR00
Initial value :	—	—	—	—	—	—	—	—
R/W :	R	R	R	R	R	R	R	R

Port data register 0 (PDR0) reads the port states. When the corresponding bit of PMR0 is 0 (general input port), the pin state is read if PDR0 is read. When the corresponding bit of PMR0 is 1 (analog input channel), 1 is read if PDR0 is read.

PDR0 is an 8-bit read-only register. When PDR0 is reset, its values become undefined.

### 11.2.3 Pin Functions

This section describes the pin functions of port 0 and their selection methods.

(1) P07/AN7 to P00/AN0

P07/AN7 to P00/AN0 are switched according to the PMR0n bit of PMR0 as shown below.

PMR0n	Pin Function
0	P0n input pin
1	ANn input pin

Note: n = 7 to 0

### 11.2.4 Pin States

Table 11.4 shows the pin 0 states in each operation mode.

**Table 11.4 Port 0 Pin States**

Pins	Reset	Active	Sleep	Standby	Watch	Subactive	Subsleep
P07/AN7 to P00/AN0	High- impedance	High- impedance	High- impedance	High- impedance	High- impedance	High- impedance	High- impedance

## 11.3 Port 1

### 11.3.1 Overview

Port 1 is an 8-bit I/O port. Table 11.5 shows the port 1 configuration.

Port 1 consists of pins that are used both as standard I/O ports (P17 to P10) and frequency division clock output (TMOW), input capture input ( $\overline{IC}$ ), or external interrupt request inputs ( $\overline{IRQ5}$  to  $\overline{IRQ0}$ ). It is switched by port mode register 1 (PMR1) and port control register 1 (PCR1).

Port 1 can select the functions of MOS pull-up transistors.

**Table 11.5 Port 1 Configuration**

Port	Function	Alternative Function
Port 1	P17 (standard I/O port)	TMOW (frequency division clock output)
	P16 (standard I/O port)	$\overline{IC}$ (input capture input)
	P15 (standard I/O port)	$\overline{IRQ5}$ (external interrupt request input)
	P14 (standard I/O port)	$\overline{IRQ4}$ (external interrupt request input)
	P13 (standard I/O port)	$\overline{IRQ3}$ (external interrupt request input)
	P12 (standard I/O port)	$\overline{IRQ2}$ (external interrupt request input)
	P11 (standard I/O port)	$\overline{IRQ1}$ (external interrupt request input)
	P10 (standard I/O port)	$\overline{IRQ0}$ (external interrupt request input)

### 11.3.2 Register Configuration

Table 11.6 shows the port 1 register configuration.

**Table 11.6 Port 1 Register Configuration**

Name	Abbrev.	R/W	Size	Initial Value	Address*
Port mode register 1	PMR1	R/W	Byte	H'00	H'FFCE
Port control register 1	PCR1	W	Byte	H'00	H'FFD1
Port data register 1	PDR1	R/W	Byte	H'00	H'FFC1
MOS pull-up select register 1	PUR1	R/W	Byte	H'00	H'FFE1

Note: \* Lower 16 bits of the address.

**(1) Port Mode Register 1 (PMR1)**

Bit :	7	6	5	4	3	2	1	0
	PMR17	PMR16	PMR15	PMR14	PMR13	PMR12	PMR11	PMR10
Initial value :	0	0	0	0	0	0	0	0
R/W :	R/W	R/W	R/W	R/W	R/W	R/W	R/W	R/W

Port mode register 1 (PMR1) controls switching of each pin function of port 1. The switching is specified in a unit of bit.

PMR1 is an 8-bit read/write enable register. When reset, PMR1 is initialized to H'00.

Note the following items when the pin functions are switched by PMR1.

- (1) If port 1 is set to an  $\overline{IC}$  input pin and  $\overline{IRQ5}$  to  $\overline{IRQ0}$  by PMR1, the pin level needs be set to the high or low level regardless of the active mode and low power consumption mode. The pin level must not be set to an intermediate level.
- (2) When the pin functions of P16/ $\overline{IC}$  and P15/ $\overline{IRQ5}$  to P10/ $\overline{IRQ0}$  are switched by PMR1, they are incorrectly recognized as edge detection according to the state of a pin signal and a detection signal may be generated. To prevent this, perform the operation in the following procedure.
  - (a) Before switching the pin functions, inhibit an interrupt enable flag from being interrupted.
  - (b) After having switched the pin functions, clear the relevant interrupt request flag to 0 by a single instruction.

**(Program Example)**

```

:
MOV.B ROL, @IENR ..... Interrupt disabled
MOV.B R1L, @PMR1 ..... Pin function change
NOP ..... Optional instruction
BCLR m @IRQR ..... Applicable interrupt clear
MOV.B R1L, @IENR ..... Interrupt enabled
:

```

**Bit 7—P17/TMOW Pin Switching (PMR17):** PMR17 sets whether the P17/TMOW pin is used as a P17 I/O pin or a TMOW pin for the frequency division clock output.

**Bit 7**

PMR17	Description
0	The P17/TMOW pin functions as a P17 I/O pin (Initial value)
1	The P17/TMOW pin functions as a TMOW output pin

**Bit 6—P16/ $\overline{IC}$  Pin Switching (PMR16):** PMR16 sets whether the P16/ $\overline{IC}$  pin as a P16 I/O pin or an  $\overline{IC}$  pin for the input capture input of the prescaler unit. The  $\overline{IC}$  pin has a built-in noise cancel circuit. See section 22, Prescaler Unit.

**Bit 6**

PMR16	Description
0	The P16/ $\overline{IC}$ pin functions as a P16 I/O pin (Initial value)
1	The P16/ $\overline{IC}$ pin functions as an $\overline{IC}$ input pin

**Bits 5 to 0—P15/ $\overline{IRQ5}$  to P10/ $\overline{IRQ0}$  Pin Switching (PMR15 to PMR10):** PMR15 to PMR10 set whether the P1n/ $\overline{IRQn}$  pin is used as a P1n I/O pin or an  $\overline{IRQn}$  pin for the external interrupt request input.

**Bit n**

PMR1n	Description
0	The P1n/ $\overline{IRQn}$ pin functions as a P1n I/O pin (Initial value)
1	The P1n/ $\overline{IRQn}$ pin functions as an $\overline{IRQn}$ input pin

Note: n = 5 to 0

**(2) Port Control Register 1 (PCR1)**

Bit :	7	6	5	4	3	2	1	0
	PCR17	PCR16	PCR15	PCR14	PCR13	PCR12	PCR11	PCR10
Initial value :	0	0	0	0	0	0	0	0
R/W :	W	W	W	W	W	W	W	W

Port control register 1 (PCR1) controls the I/Os of pins P17 to P10 of port 1 in a unit of bit. When PCR1 is set to 1, the corresponding P17 to P10 pins become output pins, and when it is set to 0, they become input pins. When the relevant pin is set to a general I/O by PMR1, settings of PCR1 and PDR1 become valid.

PCR1 is an 8-bit write-only register. When PCR1 is read, 1 is read. When reset, PCR1 is initialized to H'00.

**Bit n**

PCR1n	Description
0	The P1n pin functions as an input pin (Initial value)
1	The P1n pin functions as an output pin

Note: n = 7 to 0

**(3) Port Data Register 1 (PDR1)**

Bit :	7	6	5	4	3	2	1	0
	PDR17	PDR16	PDR15	PDR14	PDR13	PDR12	PDR11	PDR10
Initial value :	0	0	0	0	0	0	0	0
R/W :	R/W	R/W	R/W	R/W	R/W	R/W	R/W	R/W

Port data register 1 (PDR1) stores the data for the pins P17 to P10 of port 1. When PCR1 is 1 (output), the PDR1 values are directly read if port 1 is read. Accordingly, the pin states are not affected. When PCR1 is 0 (input), the pin states are read if port 1 is read.

PDR1 is an 8-bit read/ write enable register. When reset, PDR1 is initialized to H'00.

**(4) MOS Pull-Up Select Register 1 (PUR1)**

Bit :	7	6	5	4	3	2	1	0
	PUR17	PUR16	PUR15	PUR14	PUR13	PUR12	PUR11	PUR10
Initial value :	0	0	0	0	0	0	0	0
R/W :	R/W	R/W	R/W	R/W	R/W	R/W	R/W	R/W

MOS pull-up selector register 1 (PUR1) controls the on and off of the MOS pull-up transistor of port 1. Only the pin whose corresponding bit of PCR1 was set to 0 (input) becomes valid. When the corresponding bit of PCR1 is set to 1 (output), the corresponding bit of PUR1 becomes invalid and the MOS pull-up transistor is turned off.

PUR1 is an 8-bit read/ write enable register. When reset, PUR1 is initialized to H'00.

**Bit n**

<b>PUR1n</b>	<b>Description</b>
0	The P1n pin has no MOS pull-up transistor (Initial value)
1	The P1n pin has a MOS pull-up pin

Note: n = 7 to 0



### 11.3.3 Pin Functions

This section describes the port I pin functions and their selection methods.

#### (1) P17/TMOW

P17/TMOW is switched as shown below according to the PMR17 bit in PMR1 and the PCR17 bit in PCR1.

PMR17	PCR17	Pin Function
0	0	P17 input pin
	1	P17 output pin
1	*	TMOW output pin

#### (2) P16/ $\overline{IC}$

P16/ $\overline{IC}$  is switched as shown below according to the PMR16 bit in PMR1, the NC on/off bit in prescaler unit control/status register (PCSR), and the PCR16 bit in PCR1.

PMR16	PCR16	NC on/off	Pin Function
0	0	*	P16 input pin
	1		P16 output pin
1	*	0	$\overline{IC}$ input pin
		1	Noise cancel valid
			Noise cancel invalid

#### (3) P15/ $\overline{IRQ5}$ to P10/ $\overline{IRQ0}$

P15/ $\overline{IRQ15}$  to P10/ $\overline{IRQ0}$  are switched as shown below according to the PMR1n bit in PMR1 and the PCR1n bit in PCR1.

PMR1n	PCR1n	Pin Function
0	0	P1n input pin
	1	P1n output pin
1	*	$\overline{IRQn}$ input pin

Legend: \* Don't care.

Notes: 1. n = 5 to 0

- The  $\overline{IRQ5}$  to  $\overline{IRQ0}$  input pins can select the leading or falling edge as an edge sense (the  $\overline{IRQ0}$  pin can select both edges). See section 6.2.4, IRQ Edge Select Register (IEGR).
- $\overline{IRQ1}$  or  $\overline{IRQ2}$  can be used as a timer J event input and  $\overline{IRQ3}$  can be used as a timer R input capture input. For details, see section 14, Timer J or section 16, Timer R.

### 11.3.4 Pin States

Table 11.7 shows the port 1 pin states in each operation mode.

**Table 11.7 Port 1 Pin States**

Pins	Reset	Active	Sleep	Standby	Watch	Subactive	Subsleep
P17/TMOW	High-impedance	Operation	Holding	High-impedance	High-impedance	Operation	Holding
P16/ $\overline{IC}$							
P15/ $\overline{IRQ5}$ to							
P10/ $\overline{IRQ0}$							

Note: If the  $\overline{IC}$  input pin and  $\overline{IRQ5}$  to  $\overline{IRQ0}$  input pins are set, the pin level need be set to the high or low level regardless of the active mode and low power consumption mode. Note that the pin level must not reach an intermediate level.

## 11.4 Port 2

### 11.4.1 Overview

Port 2 is an 8-bit I/O port. Table 11.8 shows the port 2 configuration.

Port 2 consists of pins that are used both as standard I/O ports (P27 to P20) and SCI clock I/O (SCK1, SCK2), receive data input (SI1, SI2), send data output (SO1, SO2), I<sup>2</sup>C bus interface clock I/O (SCL), or data I/O (SDA). It is switched by port mode register 2 (PMR2), serial mode register (SMR), serial control register 2 (SCR), I<sup>2</sup>C bus control register (ICCR), and port control register (PCR2).

Port 2 can select the MOS pull-up function.

**Table 11.8 Port 2 Configuration**

Port	Function	Alternative Function
Port 2	P27 (standard I/O port)	SCK2 (SCI2 clock I/O)
	P26 (standard I/O port)	SO2 (SCI2 transmit data output)
	P25 (standard I/O port)	SI2 (SCI2 receive data input)
	P24 (standard I/O port)	SCL (I <sup>2</sup> C bus interface clock I/O)
	P23 (standard I/O port)	SDA (I <sup>2</sup> C bus interface data I/O)
	P22 (standard I/O port)	SCK1 (SCI1 clock I/O)
	P21 (standard I/O port)	SO1 (SCI1 transmit data output)
	P20 (standard I/O port)	SI1 (SCI1 receive data input)

### 11.4.2 Register Configuration

Table 11.9 shows the port 2 register configuration.

**Table 11.9 Port 2 Register Configuration**

Name	Abbrev.	R/W	Size	Initial Value	Address*
Port mode register 2	PMR2	R/W	Byte	H'1E	H'FFCF
Port control register 2	PCR2	W	Byte	H'00	H'FFD2
Port data register 2	PDR2	R/W	Byte	H'00	H'FFC2
MOS pull-up select register 2	PUR2	R/W	Byte	H'00	H'FFE2

Note: \* Lower 16 bits of the address.

**(1) Port Mode Register 2 (PMR2)**

Bit :	7	6	5	4	3	2	1	0
	PMR27	PMR26	PMR25	—	—	—	—	PMR20
Initial value :	0	0	0	1	1	1	1	0
R/W :	R/W	R/W	R/W	—	—	—	—	R/W

Port mode register 2 (PMR2) controls switching of each pin function of port 2. The switching is specified in a unit of bit.

The switching of the P22/SCK1, P21/SO1, and P20/SI1 pin functions is controlled by SMR and SCR. See section 23, Serial Communication Interface 1 (SCI1).

PMR2 is an 8-bit read/write enable register. When reset, PMR2 is initialized to H'1E.

If the SCK1, SCK2, SI1, and SI2 input pins are set, the pin level need be set to the high or low level regardless of the active mode and low power consumption mode. Note that the pin level must not reach an intermediate level

**Bit 7—P27/SCK2 Pin Switching (PMR27):** PMR27 sets whether the P27/SCK2 pin is used as a P27 I/O pin or an SKC2 pin for the SCI2 clock I/O.

**Bit 7**

PMR27	Description	
0	The P27/SCK2 pin functions as a P27 I/O pin	(Initial value)
1	The P27/SCK2 pin functions as an SCK2 I/O pin	

**Bit 6—P26/SO2 Pin Switching (PMR26):** PMR26 sets whether the P26/SO2 pin as a P26 I/O pin or an SO2 pin for the SCI2 send data output.

**Bit 6**

PMR26	Description	
0	The P26/SO2 pin functions as a P26 I/O pin	(Initial value)
1	The P26/SO2 pin functions as an SO2 output pin	

**Bit 5—P25/SI2 Pin Switching (PMR25):** PMR26 sets whether the P25/SI2 pin as a P25 I/O pin or an SI2 pin for the SCI2 receive data input.

**Bit 5**

PMR25	Description
0	The P25/SI2 pin functions as a P25 I/O pin (Initial value)
1	The P25/SI2 pin functions as an SI2 input pin

**Bits 4 to 1—Reserved:** When the bits are read, 1 is always read. The write operation is invalid.

**Bit 0—P26/SO2 Pin PMOS Control (PMR20):** PMR20 controls the PMOS ON and OFF of the P26/SO2 pin output buffer.

**Bit 0**

PMR20	Description
0	The P26/SO2 pin functions as CMOS output (Initial value)
1	The P26/SO2 pin functions as NMOS open drain output

**(2) Port Control Register 2 (PCR2)**

Bit :	7	6	5	4	3	2	1	0
	PCR27	PCR26	PCR25	PCR24	PCR23	PCR22	PCR21	PCR20
Initial value :	0	0	0	0	0	0	0	0
R/W :	W	W	W	W	W	W	W	W

Port control register 2 (PCR2) controls the I/Os of pins P27 to P20 of port 2 in a unit of bit. When PCR2 is set to 1, the corresponding P27 to P20 pins become output pins, and when it is set to 0, they become input pins. When the relevant pin is set to a general I/O by PMR1, settings of PCR2 and PDR2 are valid.

PCR2 is an 8-bit write-only register. When PCR2 is read, 1 is read. When reset, PCR2 is initialized to H'00.

**Bit n**

PCR2n	Description
0	The P2n pin functions as an input pin (Initial value)
1	The P2n pin functions as an output pin

Note: n = 7 to 0

**(3) Port Data Register 2 (PDR2)**

Bit :	7	6	5	4	3	2	1	0
	PDR27	PDR26	PDR25	PDR24	PDR23	PDR22	PDR21	PDR20
Initial value :	0	0	0	0	0	0	0	0
R/W :	R/W	R/W	R/W	R/W	R/W	R/W	R/W	R/W

Port data register 2 (PDR2) stores the data for the pins P27 to P20 of port 2. When PCR2 is 1 (output), the PDR2 values are directly read if port 2 is read. Accordingly, the pin states are not affected. When PCR2 is 0 (input), the pin states are read if port 2 is read.

PDR2 is an 8-bit read/write enable register. When reset, PDR2 is initialized to H'00.

**(4) MOS Pull-Up Select Register 2 (PUR2)**

Bit :	7	6	5	4	3	2	1	0
	PUR27	PUR26	PUR25	PUR24	PUR23	PUR22	PUR21	PUR20
Initial value :	0	0	0	0	0	0	0	0
R/W :	R/W	R/W	R/W	R/W	R/W	R/W	R/W	R/W

MOS pull-up selector register 2 (PUR2) controls the ON and OFF of the MOS pull-up transistor of port 2. Only the pin whose corresponding bit of PCR1 was set to 0 (input) becomes valid. If the corresponding bit of PCR2 is set to 1 (output), the corresponding bit of PUR2 becomes invalid and the MOS pull-up transistor is turned off.

PUR2 is an 8-bit read/write enable register. When reset, PUR2 is initialized to H'00.

**Bit n**

<b>PMR2n</b>	<b>Description</b>
0	The P2n pin has no MOS pull-up transistor (Initial value)
1	The P2n pin has a MOS pull-up transistor

Note: n = 7 to 0

### 11.4.3 Pin Functions

This section describes the port 2 pin functions and their selection methods.

#### (1) P27/SCK2

P27/SCK2 is switched as shown below according to the PMR27 bit in PMR2, the PCR27 bit in PCR2, and the SCK2 to SCK0 bits in serial control register 2 (SCR2).

PMR27	PCR27	CKS2 to CKS0	Pin Function
0	0	*	P27 input pin
	1		P27 output pin
1	*	Other than 111	SCK2 output pin
		111	SCK2 input pin

Legend: \* Don't care.

#### (2) P26/SO2

P26/SO2 is switched as shown below according to the PMR26 bit in PMR2 and the PCR26 bit in PCR2.

PMR26	PCR26	Pin Function
0	0	P26 input pin
	1	P26 output pin
1	*	SO2 output pin

Legend: \* Don't care.

#### (3) P25/SI2

P25/SI2 is switched as shown below according to the PMR25 bit in PMR2 and the PCR25 bit in PCR2.

PMR25	PCR25	Pin Function
0	0	P25 input pin
	1	P25 output pin
1	*	SI2 input pin

Legend: \* Don't care.

## (4) P24/SCL

P24/SCL2 is switched as shown below according to the ICE bit in the I<sup>2</sup>C bus control register and the PCR24 bit in PCR2.

ICE	PCR24	Pin Function
0	0	P24 input pin
	1	P24 output pin
1	*	SCL I/O pin

Legend: \* Don't care.

## (5) P23/SDA

P23/SDA is switched as shown below according to the ICE bit in the I<sup>2</sup>C bus control register and the PCR23 bit in PCR2.

ICE	PCR23	Pin Function
0	0	P23 input pin
	1	P23 output pin
1	*	SDA I/O pin

Legend: \* Don't care.

## (6) P22/SCK1

P22/SCK1 is switched as shown below according to the PCR22 bit in PCR2, the C/ $\bar{A}$  bit in SMR, and the CKE1 and CKE0 bits in SCR.

CKE1	C/ $\bar{A}$	CKE0	PCR22	Pin Function
0	0	0	0	P22 input pin
			1	P22 output pin
		1	*	SCK1 output pin
	1	*		
1	*			SCK1 input pin

Legend: \* Don't care.



## (7) P21/SO1

P21/SO1 is switched as shown below according to the PCR21 bit in PCR2 and the TE bit in SCR.

TE	PCR21	Pin Function
0	0	P21 input pin
	1	P21 output pin
1	*	SO1 output pin

Legend: \* Don't care.

## (8) P20/SI1

P20/SI1 is switched as shown below according to the PCR20 bit in PCR2 and the RE bit in SCR.

RE	PCR20	Pin Function
0	0	P20 input pin
	1	P20 output pin
1	*	SI1 input pin

Legend: \* Don't care.

### 11.4.4 Pin States

Table 11.10 shows the port 2 pin states in each operation mode.

**Table 11.10 Port 2 Pin States**

Pins	Reset	Active	Sleep	Standby	Watch	Subactive	Subsleep
P27/SCK2	High-impedance	Operation	Holding	High-impedance	High-impedance	Operation	Holding
P26/SO2							
P25/SI2							
P24/SCL							
P23/SDA							
P22/SCK1							
P21/SO1							
P20/SI1							

Note: If the SCK1, SCK2, SI1, and SI2 input pins are set, the pin level needs be set to the high or low level regardless of the active mode and low power consumption mode. Note that the pin level must not reach an intermediate level.

## 11.5 Port 3

### 11.5.1 Overview

Port 3 is an 8-bit I/O port. Table 11.11 shows the port 3 configuration.

Port 3 consists of pins that are used both as standard I/O ports (P37 to P30) and timer J timer output (TMO), buzzer output (BUZZ), 8-bit PWN outputs (PWN3 to PWN0), SCI2 strobe output (STRB), or chip select input ( $\overline{\text{CS}}$ ). It is switched by port mode register 3 (PMR3) and port control register 3 (PCR3).

Port 3 can select the MOS pull-up function.

**Table 11.11 Port 3 Configuration**

Port	Function	Alternative Function
Port 3	P37 (standard I/O port)	TMO (timer J timer output)
	P36 (standard I/O port)	BUZZ (timer J buzzer output)
	P35 (standard I/O port)	PWM3 (8-bit PWM output)
	P34 (standard I/O port)	PWM2 (8-bit PWM output)
	P33 (standard I/O port)	PWM1 (8-bit PWM output)
	P32 (standard I/O port)	PWM0 (8-bit PWM output)
	P31 (standard I/O port)	STRB (SCI2 strobe output)
	P30 (standard I/O port)	$\overline{\text{CS}}$ (SCI2 chip select input)

### 11.5.2 Register Configuration

Table 11.12 shows the port 3 register configuration.

**Table 11.12 Port 3 Register Configuration**

Name	Abbrev.	R/W	Size	Initial Value	Address*
Port mode register 3	PMR3	R/W	Byte	H'00	H'FFD0
Port control register 3	PCR3	W	Byte	H'00	H'FFD3
Port data register 3	PDR3	R/W	Byte	H'00	H'FFC3
MOS pull-up select register 3	PUR3	R/W	Byte	H'00	H'FFE3

Note: \* Lower 16 bits of the address.

**(1) Port Mode Register 3 (PMR3)**

Bit :	7	6	5	4	3	2	1	0
	PMR37	PMR36	PMR35	PMR34	PMR33	PMR32	PMR31	PMR30
Initial value :	0	0	0	0	0	0	0	0
R/W :	R/W	R/W	R/W	R/W	R/W	R/W	R/W	R/W

Port mode register 3 (PMR3) controls switching of each pin function of port 3. The switching is specified in a unit of bit.

PMR3 is an 8-bit read/write enable register. When reset, PMR3 is initialized to H'00.

If the  $\overline{CS}$  input pin is set, the pin level need be set to the high or low level regardless of the active mode and low power consumption mode. Note that the pin level must not reach an intermediate level.

**Bit 7—P37/TMO Pin Switching (PMR37):** PMR37 sets whether the P37/TMO pin is used as a P37 I/O pin or a TMO pin for the timer J output timer.

**Bit 7**

PMR37	Description
0	The P37/TMO pin functions as a P37 I/O pin (Initial value)
1	The P37/TMO pin functions as a TMO output pin

Note: If the TMO pin is used for remote control sending, a careless timer output pulse may be output when the remote control mode is set after the output has been switched to the TMO output. Perform the switching and setting in the following order.

- [1] Set the remote control mode.
- [2] Set the TMJ-1 and 2 counter data of the timer J.
- [3] Switch the P37/TMO pin to the TMO output pin.
- [4] Set the ST bit to 1.

**Bit 6—P36/BUZZ Pin Switching (PMR36):** PMR36 sets whether the P36/BUZZ pin as a P36 I/O pin or an BUZZ pin for the timer J buzzer output. For the selection of the BUZZ output, see section14.2.2, Timer J Control Register (TMJC).

**Bit 6**

PMR36	Description
0	The P36/BUZZ pin functions as a P36 I/O pin (Initial value)
1	The P36/BUZZ pin functions as a BUZZ output pin

**Bits 5 to 2—P35/PWM3 to P32/PWM0 Pin Switching (PMR35 to PMR32):** PMR35 to PMR32 set whether the P3n/PWMm pin is used as a P3n I/O pin or a PWMm pin for the 8-bit PWM output.

**Bit n**

PMR3n	Description
0	The P3n/PWMm pin functions as a P3n I/O pin (Initial value)
1	The P3n/PWMm pin functions as a PWMm output pin

Note: n = 5 to 2, m = 3 to 0

**Bit 1—P31/STRB Pin Switching (PMR31):** PMR31 sets whether the P31/STRB pin is used as a P31 I/O pin or an STRB pin for the SCI2 strobe output.

**Bit 1**

PMR31	Description
0	The P31/STRB pin functions as a P31 I/O pin (Initial value)
1	The P31/STRB pin functions as an STRB output pin

**Bit 0—P30/ $\overline{\text{CS}}$  Pin Switching (PMR30):** PMR30 sets whether the P30/ $\overline{\text{CS}}$  pin is used as a P30 I/O pin or a  $\overline{\text{CS}}$  pin for the SCI2 chip select input.

**Bit 0**

PMR30	Description
0	The P30/ $\overline{\text{CS}}$ pin functions as a P30 I/O pin (Initial value)
1	The P30/ $\overline{\text{CS}}$ pin functions as a $\overline{\text{CS}}$ input pin

**(2) Port Control Register 3 (PCR3)**

Bit :	7	6	5	4	3	2	1	0
	PCR37	PCR36	PCR35	PCR34	PCR33	PCR32	PCR31	PCR30
Initial value :	0	0	0	0	0	0	0	0
R/W :	W	W	W	W	W	W	W	W

Port control register 3 (PCR3) controls the I/Os of pins P37 to P30 of port 3 in a unit of bit. When PCR3 is set to 1, the corresponding P37 to P30 pins become output pins, and when it is set to 0, they become input pins. When the relevant pin is set to a general I/O by PMR3, settings of PCR3 and PDR3 become valid.

PCR3 is an 8-bit write-only register. When PCR3 is read, 1 is read. When reset, PCR3 is initialized to H'00.

**Bit n**

PCR3n	Description
0	The P3n pin functions as an input pin (Initial value)
1	The P3n pin functions as an output pin

Note: n = 7 to 0

**(3) Port Data Register 3 (PDR3)**

Bit :	7	6	5	4	3	2	1	0
	PDR37	PDR36	PDR35	PDR34	PDR33	PDR32	PDR31	PDR30
Initial value :	0	0	0	0	0	0	0	0
R/W :	R/W	R/W	R/W	R/W	R/W	R/W	R/W	R/W

Port data register 3 (PDR3) stores the data for the pins P37 to P30 of port 3. When PCR3 is 1 (output), the PDR3 values are directly read if port 3 is read. Accordingly, the pin states are not affected. When PCR3 is 0 (input), the pin states are read if port 3 is read.

PDR3 is an 8-bit read/write enable register. When reset, PDR3 is initialized to H'00.

**(4) MOS Pull-Up Select Register 3 (PUR3)**

Bit :	7	6	5	4	3	2	1	0
	PUR37	PUR36	PUR35	PUR34	PUR33	PUR32	PUR31	PUR30
Initial value :	0	0	0	0	0	0	0	0
R/W :	R/W	R/W	R/W	R/W	R/W	R/W	R/W	R/W

MOS pull-up selector register 3 (PUR3) controls the ON and OFF of the MOS pull-up transistor of port 3. Only the pin whose corresponding bit of PCR3 was set to 0 (input) becomes valid. If the corresponding bit of PCR3 is set to 1 (output), the corresponding bit of PUR3 becomes invalid and the MOS pull-up transistor is turned off.

PUR3 is an 8-bit read/write enable register. When reset, PUR3 is initialized to H'00.

**Bit n**

PCR3n	Description
0	The P3n pin has no MOS pull-up transistor (Initial value)
1	The P3n pin has a MOS pull-up transistor

Note: n = 7 to 0

**11.5.3 Pin Functions**

This section describes the port 3 pin functions and their selection methods.

**(1) P37/TMO**

P37/TMO is switched as shown below according to the PMR37 bit in PMR3 and the PCR37 bit in PCR3.

PMR37	PCR37	Pin Function
0	0	P37 input pin
	1	P37 output pin
1	*	TMO output pin

Legend: \* Don't care.

## (2) P36/BUZZ

P36/BUZZ is switched as shown below according to the PMR36 bit in PMR3 and the PCR36 bit in PCR3.

PMR36	PCR36	Pin Function
0	0	P36 input pin
	1	P36 output pin
1	*	BUZZ output pin

Legend: \* Don't care.

## (3) P35/PWM3 to P32/PWM0

P35/PWM3 to P32/PWM0 are switched as shown below according to the PMR3n bit in PMR3 and the PCR3n bit in PCR3.

PMR3n	PCR3n	Pin Function
0	0	P3n input pin
	1	P3n output pin
1	*	PWMm output pin

Legend: \* Don't care.

Note: n = 5 to 2, m = 3 to 0

## (4) P31/STRB

P31/STRB is switched as shown below according to the PMR31 bit in PMR3 and the PCR31 bit in PCR3.

PMR31	PCR31	Pin Function
0	0	P31 input pin
	1	P31 output pin
1	*	STRB output pin

Legend: \* Don't care.

(5) P30/ $\overline{\text{CS}}$ 

P30/ $\overline{\text{CS}}$  is switched as shown below according to the PMR30 bit in PMR3 and the PCR30 bit in PCR3.

PMR30	PCR30	Pin Function
0	0	P30 input pin
	1	P30 output pin
1	*	$\overline{\text{CS}}$ input pin

Legend: \* Don't care.

### 11.5.4 Pin States

Table 11.13 shows the port 3 pin states in each operation mode.

**Table 11.13 Port 3 Pin States**

Pins	Reset	Active	Sleep	Standby	Watch	Subactive	Subsleep
P37/TMO P36/BUZZ P35/PWM3 to P32/PWM0 P31/STRB P30/ $\overline{\text{CS}}$	High-impedance	Operation	Holding	High-impedance	High-impedance	Operation	Holding

Note: If the  $\overline{\text{CS}}$  input pin is set, the pin level need be set to the high or low level regardless of the active mode and low power consumption mode. Note that the pin level must not reach an intermediate level.



## 11.6 Port 4

### 11.6.1 Overview

Port 4 is an 8-bit I/O port. Table 11.14 shows the port 4 configuration.

Port 4 consists of pins that are used both as standard I/O ports (P47 to P40) and output compare output (FTOA, FTOB), input capture input (FTIA, FTIB, FTIC, FTID) or 14-bit PWM output (PWM14). It is switched by port mode register 4 (PRM4), timer output compare control register (TOCR), and port control register 4 (PCR4).

**Table 11.14 Port 4 Configuration**

Port	Function	Alternative Function
Port 4	P47 (standard I/O port)	None
	P46 (standard I/O port)	FTOB (timer X1 output compare output)
	P45 (standard I/O port)	FTOA (timer X1 output compare output)
	P44 (standard I/O port)	FTID (timer X1 input capture input)
	P43 (standard I/O port)	FTIC (timer X1 input capture input)
	P42 (standard I/O port)	FTIB (timer X1 input capture input)
	P41 (standard I/O port)	FTIA (timer X1 input capture input)
	P40 (standard I/O port)	PWM14 (14-bit PWM output)

### 11.6.2 Register Configuration

Table 11.15 shows the port 4 register configuration.

**Table 11.15 Port 4 Register Configuration**

Name	Abbrev.	R/W	Size	Initial Value	Address*
Port mode register 4	PMR4	R/W	Byte	H'FE	H'FFDB
Port control register 4	PCR4	W	Byte	H'00	H'FFD4
Port data register 4	PDR4	R/W	Byte	H'00	H'FFC4

Note: \* Lower 16 bits of the address.

**(1) Port Mode Register 4 (PMR4)**

Bit :	7	6	5	4	3	2	1	0
	—	—	—	—	—	—	—	PMR40
Initial value :	1	1	1	1	1	1	1	0
R/W :	—	—	—	—	—	—	—	R/W

Port mode register 4 (PMR4) controls switching of the P40/PWM14 pin function. The switchings of the P46/FTOB and P45/FTOA functions are controlled by TOCR. See section 17, Timer X1. The FTIA, FTIB, FTIC, and FTID inputs always function.

PMR4 is an 8-bit read/write enable register. When reset, PMR4 is initialized to H'FE.

Because the FTIA, FTIB, FTIC, and FTID inputs always function, the alternative pin need always be set to the high or low level regardless of the active mode and low power consumption mode. Note that the pin level must not reach an intermediate level (excluding reset, standby, and watch modes).

Because the FTIA, FTIB, FTIC, and FTID inputs always function, each input uses the input edge to the alternative general I/O pins P44, P43, P42, and P41 as input signals.

**Bits 7 to 1—Reserved:** When the bits are read, 1 is always read. The write operation is invalid.

**Bit 0—P40/PWM14 Pin Switching (PMR40):** PMR40 sets whether the P40/PWM pin is used as a P40 I/O pin or a PWM14 pin for the 14-bit PWM square wave output.

**Bit 0**

PMR40	Description
0	The P40/PWM14 pin functions as a P40 I/O pin (Initial value)
1	The P40/PWM14 pin functions as a PWM14 output pin

**(2) Port Control Register 4 (PCR4)**

Bit :	7	6	5	4	3	2	1	0
	PCR47	PCR46	PCR45	PCR44	PCR43	PCR42	PCR41	PCR40
Initial value :	0	0	0	0	0	0	0	0
R/W :	W	W	W	W	W	W	W	W

Port control register 4 (PCR4) controls the I/Os of pins P47 to P40 of port 4 in a unit of bit. When PCR4 is set to 1, the corresponding P47 to P40 pins become output pins, and when it is set to 0, they become input pins. When the relevant pin is set to a general I/O by PMR4, settings of PCR4 and PDR4 become valid.

PCR4 is an 8-bit write-only register. When PCR4 is read, 1 is read. When reset, PCR4 is initialized to H'00.

**Bit n**

PCR4n	Description
0	The P4n pin functions as an input pin (Initial value)
1	The P4n pin functions as an output pin

Note: n = 7 to 0

**(3) Port Data Register 4 (PDR4)**

Bit :	7	6	5	4	3	2	1	0
	PDR47	PDR46	PDR45	PDR44	PDR43	PDR42	PDR41	PDR40
Initial value :	0	0	0	0	0	0	0	0
R/W :	R/W	R/W	R/W	R/W	R/W	R/W	R/W	R/W

Port data register 4 (PDR4) stores the data for the pins P47 to P40 of port 4. When PCR4 is 1 (output), the PDR4 values are directly read if port 3 is read. Accordingly, the pin states are not affected. When PCR4 is 0 (input), the pin states are read if port 4 is read.

PDR4 is an 8-bit read/write enable register. When reset, PDR4 is initialized to H'00.

**11.6.3 Pin Functions**

This section describes the port 4 pin functions and their selection methods.

**(1) P47/FTCI**

P47/FTCI is switched as shown below according to the PCR47 bit in PCR4.

PCR47	Pin Function
0	P47 input pin
1	P47 output pin

## (2) P46/FTOB

P46/FTOB is switched as shown below according to the PCR46 bit in PCR4 and the OEB bit in TOCR.

OEB	PCR46	Pin Function
0	0	P46 input pin
	1	P46 output pin
1	*	FTOB output pin

Legend: \* Don't care.

## (3) P45/FTOA

P45/FTOA is switched as shown below according to the PCR45 bit in PCR4 and the OEA bit in TOCR.

OEA	PCR45	Pin Function
0	0	P45 input pin
	1	P45 output pin
1	*	FTOA output pin

Legend: \* Don't care.

## (4) P44/FTID

P44/FTID is switched as shown below according to the PCR44 bit in PCR4.

PCR44	Pin Function
0	P44 input pin FTID input pin
1	P44 output pin

## (5) P43/FTIC

P43/FTIC is switched as shown below according to the PCR43 bit in PCR4.

PCR43	Pin Function
0	P43 input pin FTIC input pin
1	P43 output pin

## (6) P42/FTIB

P42/FTIB is switched as shown below according to the PCR42 bit in PCR4.

PCR42	Pin Function
0	P42 input pin FTIB input pin
1	P42 output pin

## (7) P41/FTIA

P41/FTIA is switched as shown below according to the PCR41 bit in PCR4.

PCR41	Pin Function
0	P41 input pin FTIA input pin
1	P41 output pin

## (8) P40/PWM14

P40/PWM14 is switched as shown below according to the PMR40 bit in PMR4 and the PCR40 bit in PCR4.

PMR40	PCR40	Pin Function
0	0	P40 input pin
	1	P40 output pin
1	*	PWM14 input pin

Legend: \* Don't care.

### 11.6.4 Pin States

Table 11.16 shows the port 4 pin states in each operation mode.

**Table 11.16 Port 4 Pin States**

<b>Pins</b>	<b>Reset</b>	<b>Active</b>	<b>Sleep</b>	<b>Standby</b>	<b>Watch</b>	<b>Subactive</b>	<b>Subsleep</b>
P47	High-impedance	Operation	Holding	High-impedance	High-impedance	Operation	Holding
P46/FTOB							
P45/FTOA							
P44/FTID							
P43/FTIC							
P42/FTIB							
P41/FTIA							
P40/PWM14							

Note: Because the FTIA, FTIB, FTIC, and FTID inputs always function, the alternative pin need be set to the high or low level regardless of the active mode and low power consumption mode. Note that the pin level must not reach an intermediate level (excluding reset, standby, and watch modes).

## 11.7 Port 5

### 11.7.1 Overview

Port 5 is a 4-bit I/O port. Table 11.17 shows the port 5 configuration.

Port 5 consists of pins that are used both as standard I/O ports (P53 to P50) and realtime output port trigger input (TRIG), timer B event input (TMBI), or A/D conversion start external trigger input ( $\overline{\text{ADTRG}}$ ). It is switched by port mode register 5 (PMR5), A/D trigger select register (ADTSR), and port control register 5 (PCR5).

**Table 11.17 Port 5 Configuration**

Port	Function	Alternative Function
Port 5	P53 (standard I/O port)	TRIG (realtime output port trigger input)
	P52 (standard I/O port)	TMBI (timer B event input)
	P51 (standard I/O port)	None
	P50 (standard I/O port)	$\overline{\text{ADTRG}}$ (A/D conversion start external trigger input)

### 11.7.2 Register Configuration

Table 11.18 shows the port 5 register configuration.

**Table 11.18 Port 5 Register Configuration**

Name	Abbrev.	R/W	Size	Initial Value	Address*
Port mode register 5	PMR5	R/W	Byte	H'F1	H'FFDC
Port control register 5	PCR5	W	Byte	H'F0	H'FFD5
Port data register 5	PDR5	R/W	Byte	H'F0	H'FFC5

Note: \* Lower 16 bits of the address.

**(1) Port Mode Register 5 (PMR5)**

Bit :	7	6	5	4	3	2	1	0
	—	—	—	—	PMR53	PMR52	PMR51	—
Initial value :	1	1	1	1	0	0	0	1
R/W :	—	—	—	—	R/W	R/W	R/W	—

Port mode register 5 (PMR5) controls switching of each pin function of port 5 and specifies the edge sense of the timer B event input (TMBI).

The switching of the P50/ $\overline{\text{ADTRG}}$  pin function is controlled by ADTSR. See section 26, A/D Converter.

PMR5 is an 8-bit read/write enable register. When reset, PMR5 is initialized to H'F1.

If the TRIG, TMBI, and ADTRG pin pins are set, the alternative pin need always be set to the high or low level regardless of the active mode and low power consumption mode. Note that the pin level must not reach an intermediate level.

**Bits 7 to 4—Reserved:** When the bits are read, 1 is always read. The write operation is invalid.

**Bit 3—P53/TRIG Pin Switching (PMR53):** PMR53 sets whether the P53/TRIG pin is used as a P53 I/O pin or a TRIG pin for the realtime output port trigger input.

**Bit 3**

PMR53	Description
0	The P53/TRIG pin functions as a P53 I/O pin (Initial value)
1	The P53/TRIG pin functions as a TRIG input pin

**Bit 2—P52/TMBI Pin Switching (PMR52):** PMR52 sets whether the P52/TMBI pin is used as a P52 I/O pin or a TMBI pin for the timer B event input.

**Bit 2**

PMR52	Description
0	The P52/TMBI pin functions as a P52 I/O pin (Initial value)
1	The P52/TMBI pin functions as a TMBI input pin



**Bit 1—Timer B event Input Edge Select (PMR51):** PMR51 selects the input edge sense of the TMBI pin.

### Bit 1

PMR51	Description
0	The timer B event input detects the falling edge (Initial value)
1	The timer B event input detects the rising edge

### Bit 0—Reserved

When the bit is read, 1 is always read. The write operation is invalid.

## (2) Port Control Register 5 (PCR5)

Bit :	7	6	5	4	3	2	1	0
	—	—	—	—	PCR53	PCR52	PCR51	PCR50
Initial value :	1	1	1	1	0	0	0	0
R/W :	—	—	—	—	W	W	W	W

Port control register 5 (PCR5) controls the I/Os of pins P53 to P50 of port 5 in a unit of bit. When PCR5 is set to 1, the corresponding P53 to P50 pins become output pins, and when it is set to 0, they become input pins. When the relevant pin is set to a general I/O, settings of PCR5 and PDR5 are valid.

PCR5 is an 8-bit write-only register. When PCR5 is read, 1 is read. When reset, PCR5 is initialized to H'F0.

Bits 7 to 4 are reserved bits.

### Bit n

PCR5n	Description
0	The P5n pin functions as an input pin (Initial value)
1	The P5n pin functions as an output pin

Note: n = 3 to 0

**(3) Port Data Register 5 (PDR5)**

Bit :	7	6	5	4	3	2	1	0
	—	—	—	—	PDR53	PDR52	PDR51	PDR50
Initial value :	1	1	1	1	0	0	0	0
R/W :	—	—	—	—	R/W	R/W	R/W	R/W

Port data register 5 (PDR5) stores the data for the pins P53 to P50 of port 5. When PCR5 is 1 (output), the PDR5 values are directly read if port 5 is read. Accordingly, the pin states are not affected. When PCR5 is 0 (input), the pin states are read if port 5 is read.

PDR5 is an 8-bit read/write enable register. When reset, PDR5 is initialized to H'F0.

Bits 7 to 4 are reserved bits.

**11.7.3 Pin Functions**

This section describes the port 5 pin functions and their selection methods.

**(1) P53/TRIG**

P53/TRIG is switched as shown below according to the PMR53 bit in PMR5 and the PCR53 bit in PCR5.

<b>PMR53</b>	<b>PCR53</b>	<b>Pin Function</b>
0	0	P53 input pin
	1	P53 output pin
1	*	TRIG input pin

Legend: \* Don't care.

**(2) P52/TMBI**

P52/TMBI is switched as shown below according to the PMR52 bit in PMR5 and the PCR52 bit in PCR5.

<b>PMR52</b>	<b>PCR52</b>	<b>Pin Function</b>
0	0	P52 input pin
	1	P52 output pin
1	*	TMBI input pin

Legend: \* Don't care.

## (3) P51

P51 is switched as shown below according to the PCR51 bit in PCR5.

PCR51	Pin Function
0	P51 input pin
1	P51 output pin

(4) P50/ $\overline{\text{ADTRG}}$ 

P50/ $\overline{\text{ADTRG}}$  is switched as shown below according to the PCR50 bit in PCR5 and the TRGS1 and TRG0 bits in ADTSR.

TRGS1, TRGS0	PCR31	Pin Function
Other than 11	0	P50 input pin
11	1	P50 output pin
11	*	$\overline{\text{ADTRG}}$ input pin

Legend: \* Don't care.

### 11.7.4 Pin States

Table 11.19 shows the port 5 pin states in each operation mode.

**Table 11.19 Port 3 Pin States**

Pins	Reset	Active	Sleep	Standby	Watch	Subactive	Subsleep
P53/TRIG	High-	Operation	Holding	High-	High-	Operation	Holding
P52/TMBI	impedance			impedance	impedance		
P51							
P50/ $\overline{\text{ADTRG}}$							

Note: If the TRIG, TMBI, and  $\overline{\text{ADTRG}}$  input pins are set, the alternative pin need always be set to the high or low level regardless of the active mode and low power consumption mode. Note that the pin level must not reach an intermediate level.

## 11.8 Port 6

### 11.8.1 Overview

Port 6 is an 8-bit I/O port. Table 11.20 shows the port 6 configuration.

Port 6 consists of pins that are used both as standard I/O ports (P67 to P60) and realtime output ports (RP7 to RP0). It is switched by port mode register 6 (PMR6) and port control register 6 (PCR6).

The realtime output function can instantaneously switch the output data by an external or internal trigger input.

**Table 11.20 Port 6 Configuration**

Port	Function	Alternative Function
Port 6	P67 (standard I/O port)	RP7 (realtime output port pin)
	P66 (standard I/O port)	RP6 (realtime output port pin)
	P65 (standard I/O port)	RP5 (realtime output port pin)
	P64 (standard I/O port)	RP4 (realtime output port pin)
	P63 (standard I/O port)	RP3 (realtime output port pin)
	P62 (standard I/O port)	RP2 (realtime output port pin)
	P61 (standard I/O port)	RP1 (realtime output port pin)
	P60 (standard I/O port)	RP0 (realtime output port pin)

## 11.8.2 Register Configuration

Table 11.21 shows the port 6 register configuration.

**Table 11.21 Port 6 Register Configuration**

Name	Abbrev.	R/W	Size	Initial Value	Address*
Port mode register 6	PMR6	R/W	Byte	H'00	H'FFDD
Port control register 6	PCR6	W	Byte	H'00	H'FFD6
Port data register 6	PDR6	R/W	Byte	H'00	H'FFC6
Realtime output trigger select register	RTPSR	R/W	Byte	H'00	H'FFE5
Realtime output trigger edge select register	RTPEGR	R/W	Byte	H'FC	H'FFE4
Port control register slave 6	PCRS6	—	Byte	H'00	—
Port data register slave 6	PDRS6	—	Byte	H'00	—

Note: \* Lower 16 bits of the address.

### (1) Port Mode Register 6 (PMR6)

Bit :	7	6	5	4	3	2	1	0
	PMR67	PMR66	PMR65	PMR64	PMR63	PMR62	PMR61	PMR60
Initial value :	0	0	0	0	0	0	0	0
R/W :	R/W	R/W	R/W	R/W	R/W	R/W	R/W	R/W

Port mode register 6 (PMR6) controls switching of each pin function of port 6. The switching is specified in units of bits.

PMR6 is an 8-bit read/write enable register. When reset, PMR6 is initialized to H'00.

**Bits 7 to 0—P67/RP7 to P60/RP0 Pin Switching (PMR67 to PMR60):** PMR67 to PMR60 set whether the P<sub>6n</sub>/RP<sub>n</sub> pin is used as a P<sub>6n</sub> I/O pin or an RP<sub>n</sub> pin for the realtime output port.

**Bit n**

PMR6n	Description
0	The P <sub>6n</sub> /RP <sub>n</sub> pin functions as a P <sub>6n</sub> I/O pin (Initial value)
1	The P <sub>6n</sub> /RP <sub>n</sub> pin functions as an RP <sub>n</sub> output pin

Note: n = 7 to 0

**(2) Port Control Register 6 (PCR6)**

Bit :	7	6	5	4	3	2	1	0
	PCR67	PCR66	PCR65	PCR64	PCR63	PCR62	PCR61	PCR60
Initial value :	0	0	0	0	0	0	0	0
R/W :	W	W	W	W	W	W	W	W

Port control register 6 (PCR6) selects the general I/O of port 6 and controls the realtime output in a unit of bit together with PMR6.

When PMR6 = 0, the corresponding P67 to P60 pins become general output pins if PCR6 is set to 1, and they become general input pins if it is set to 0.

When PMR6 = 1, PCR6 controls the corresponding RP7 to RP0 realtime output pins. For details, see section 11.8.4, Operation.

PCR6 is an 8-bit write-only register. When PCR6 is read, 1 is read. When reset, PCR6 is initialized to H'00.

PMR6	PCR6	
Bit n	Bit n	
PMR6n	PCR6n	Description
0	0	The P6n/RPn pin functions as a P6n general I/O input pin (Initial value)
	1	The P6n/RPn pin functions as a P6n general output pin
1	*	The P6n/RPn pin functions as an RPn realtime output pin

Legend: \* Don't care.

Note: n = 7 to 0

**(3) Port Data Register 6 (PDR6)**

Bit :	7	6	5	4	3	2	1	0
	PDR67	PDR66	PDR65	PDR64	PDR63	PDR62	PDR61	PDR60
Initial value :	0	0	0	0	0	0	0	0
R/W :	R/W	R/W	R/W	R/W	R/W	R/W	R/W	R/W

Port data register 6 (PDR6) stores the data for the pins P67 to P60 of port 6.

For PMR6 = 0, when PCR6 is 1 (output), the PDR6 values are directly read if port 6 is read.

Accordingly, the pin states are not affected. When PCR6 is 0 (input), the pin states are read if port 6 is read.

For PMR6 = 1, port 6 becomes a realtime output pin. For details, see section 11.8.4, Operation.

PDR6 is an 8-bit read/write enable register. When reset, PDR6 is initialized to H'00.

**(4) Realtime Output Trigger Select Register (RTPSR)**

Bit :	7	6	5	4	3	2	1	0
	RTPSR7	RTPSR6	RTPSR5	RTPSR4	RTPSR3	RTPSR2	RTPSR1	RTPSR0
Initial value :	0	0	0	0	0	0	0	0
R/W :	R/W	R/W	R/W	R/W	R/W	R/W	R/W	R/W

The realtime output trigger select register (RTPSR) sets whether the external trigger (TRIG pin input) or the internal trigger (HSW) is used as a trigger input for the realtime output in a unit of bit. For the internal trigger HSW, see section 28.4, HSW (Head-Switch) Timing Generator. RTPSR is an 8-bit read/write enable register. When reset, RTPSR is initialized to H'00.

**Bit n**

RTPSRn	Description
0	Selects the external trigger (TRIG pin input) as a trigger input (Initial value)
1	Selects the internal trigger (HSW) a trigger input

Note: n = 7 to 0

**(5) Real Time Output Trigger Edge Select Register (RTPEGR)**

Bit :	7	6	5	4	3	2	1	0
	—	—	—	—	—	—	RTPEGR1	RTPEGR0
Initial value :	1	1	1	1	1	1	0	0
R/W :	—	—	—	—	—	—	R/W	R/W

The realtime output trigger edge select register (RTPEGR) specifies the edge sense of the external or internal trigger input for the realtime output.

RTPEGR is an 8-bit read/write enable register. When reset, RTPEGR is initialized to H'FC.

**Bits 7 to 2—Reserved:** When the bits are read, 1 is always read. The write operation is invalid.

**Bits 1 and 0—Realtime Output Trigger Edge Select (RTPEGR1, RTPEGR0):** RTPEGR1 and RTPEGR0 select the edge sense of the external or internal trigger input for the realtime output.

Bit 1	Bit 0	Description
RTPEGR1	RTPEGR0	
0	0	Inhibits a trigger input (Initial value)
	1	Selects the rising edge of a trigger input
1	0	Selects the falling edge of a trigger input
	1	Selects both the leading and falling edges of a trigger input

### 11.8.3 Pin Functions

This section describes the port 6 pin functions and their selection methods.

#### (1) P67/RP7 to P60/RP0

P67/RP7 to P60/RP0 are switched as shown below according to the PMR6n bit in PMR6 and the PCR6n bit in PCR6.

PMR6n	PCR6n	Pin Function	Output Value	Value When PDR6n was read
0	0	P6n input pin	—	P6n pin
	1	P6n output pin	PDR6n	PDR6n
1	0	RPn output pin	High-impedance*	
	1		PDRS6n*	

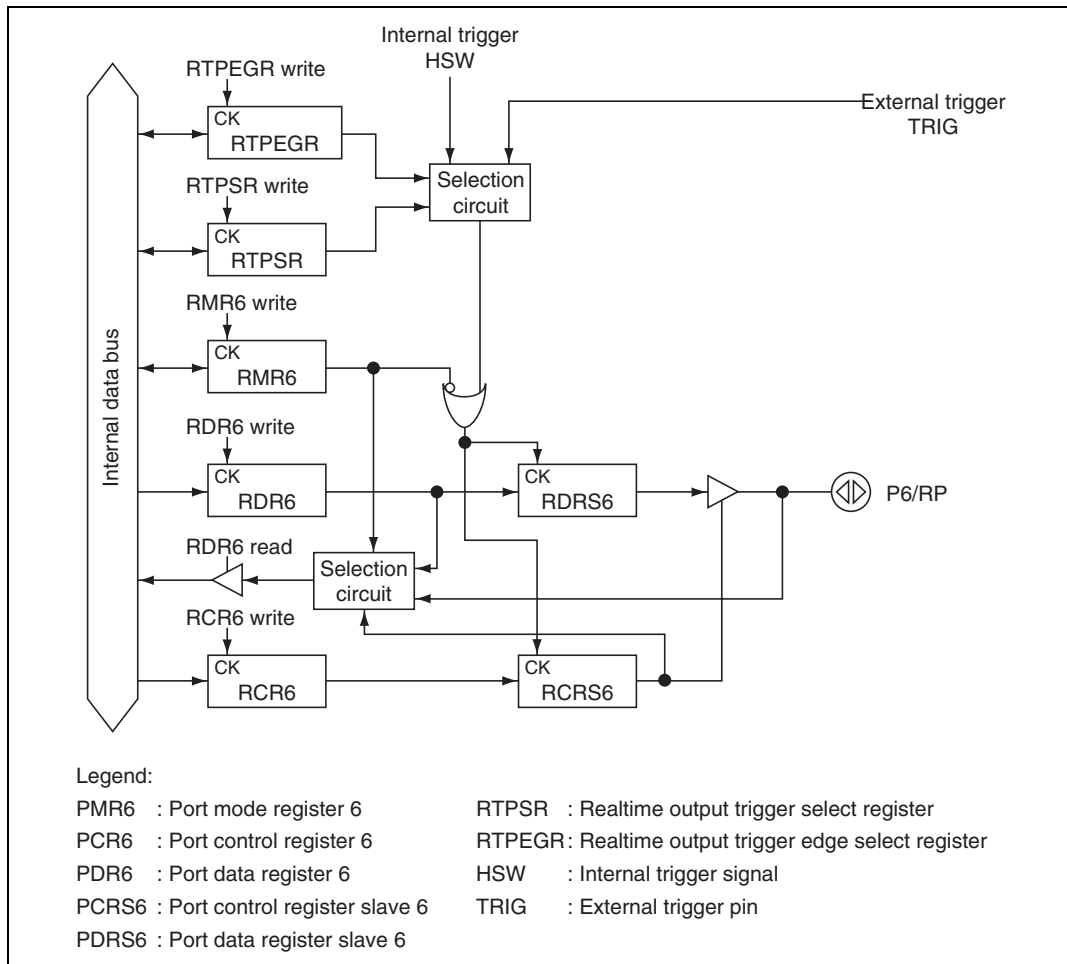
Notes: n = 7 to 0

\* When PMR6n = 1 (realtime output pin), indicates the state after the PCR6n setup value has been transferred to PCRS6n by a trigger input.



## 11.8.4 Operation

Port 6 can be used as a realtime output port or general I/O output port by PMR6. Port 6 functions as a realtime output port when PMR6 = 1 and as a general I/O port when PMR6 = 0. The operation per port 6 function is shown below. (See figure 11.2.)



**Figure 11.2 Port 6 Function Block Diagram**

## (1) Operation of the realtime output port (PMR6 = 1)

When PMR6 is 1, it operates as a realtime output port. When a trigger is input, PMR6 transfers the PDR6 data to PDRS6 and the PCR6 data to PCRS6, respectively. In this case, when PCRS6 is 1, the PDRS6 data of the corresponding bit is output to the RP pin. When PCRS6 is 0, the RP pin of the corresponding bit is output to the high-impedance state. In other words, the pin output state (High or Low) or high-impedance state can instantaneously be switched by a trigger input.

Adversely, when PDR6 is read, the PDR6 values are read regardless of the PCR6 and PCRS6 values.

## (2) Operation of the general I/O port (PMR6 = 0)

When PMR6 is 0, it operates as a general I/O port. When data is written to PDR6, the same data is also written to PDRS6. Accordingly, because both PDR6 and PDRS6 and both PCR6 and PCRS6 can be handled as one register, respectively, they can be used in the same way as a normal general I/O port. In other words, if PCR6 is 1, the PDR6 data of the corresponding bit is output to the P6 pin. If PCR6 is 0, the P6 pin of the corresponding bit becomes an input.

Adversely, assuming that PDR6 is read, the PDR6 values are read when PCR6 is 1 and the pin values are read when PCR6 is 0.

### 11.8.5 Pin States

Table 11.22 shows the port 6 pin states in each operation mode.

**Table 11.22 Port 6 Pin States**

Pins	Reset	Active	Sleep	Standby	Watch	Subactive	Subsleep
P67/RP7 to P60/RP0	High- impedance	Operation	Holding	High- impedance	High- impedance	Operation	Holding

## 11.9 Port 7

### 11.9.1 Overview

Port 7 is an 8-bit I/O port. Table 11.23 shows the port 7 configuration.

Port 7 consists of pins that are used both as standard I/O ports (P77 to P70) and HSW timing generation circuit (programmable pattern generator: PPG) outputs (PPG7 to PPG0). It is switched by port mode register 7 (PMR7) and port control register 7 (PCR7).

For the programmable generator (PPG), see section 28.4, HSW (Head-Switch) Timing Generator.

**Table 11.23 Port 7 Configuration**

Port	Function	Alternative Function
Port 7	P77 (standard I/O port)	PPG7 (HSW timing output)
	P76 (standard I/O port)	PPG6 (HSW timing output)
	P75 (standard I/O port)	PPG5 (HSW timing output)
	P74 (standard I/O port)	PPG4 (HSW timing output)
	P73 (standard I/O port)	PPG3 (HSW timing output)
	P72 (standard I/O port)	PPG2 (HSW timing output)
	P71 (standard I/O port)	PPG1 (HSW timing output)
	P70 (standard I/O port)	PPG0 (HSW timing output)

### 11.9.2 Register Configuration

Table 11.24 shows the port 7 register configuration.

**Table 11.24 Port 7 Register Configuration**

Name	Abbrev.	R/W	Size	Initial Value	Address*
Port mode register 7	PMR7	R/W	Byte	H'00	H'FFDE
Port control register 7	PCR7	W	Byte	H'00	H'FFD7
Port control register 7	PDR7	R/W	Byte	H'00	H'FFC7

Note: \* Lower 16 bits of the address.

**(1) Port Mode Register 7 (PMR7)**

Bit :	7	6	5	4	3	2	1	0
	PMR77	PMR76	PMR75	PMR74	PMR73	PMR72	PMR71	PMR70
Initial value :	0	0	0	0	0	0	0	0
R/W :	R/W	R/W	R/W	R/W	R/W	R/W	R/W	R/W

Port mode register 7 (PMR7) controls switching of each pin function of port 7. The switching is specified in a unit of bit.

PMR7 is an 8-bit read/write enable register. When reset, PMR7 is initialized to H'00.

**Bits 7 to 0: P77/PPG7 to P70/PPG0 Pin Switching (PMR77 to PMR70)**

PMR77 to PMR70 set whether the P7n/PPGn pin is used as a P7n I/O pin or a PPGn pin for the HSW timing generation circuit output.

**Bit n**

PMR7n	Description
0	The P7n/PPGn pin functions as a P7n I/O pin (Initial value)
1	The P7n/PPGn pin functions as a PPGn output pin

Note: n = 7 to 0

**(2) Port Control Register 7 (PCR7)**

Bit :	7	6	5	4	3	2	1	0
	PCR77	PCR76	PCR75	PCR74	PCR73	PCR72	PCR71	PCR70
Initial value :	0	0	0	0	0	0	0	0
R/W :	W	W	W	W	W	W	W	W

Port control register 7 (PCR7) controls the I/Os of pins P77 to P70 of port 7 in a unit of bit.

When PCR7 is set to 1, the corresponding P77 to P70 pins become output pins, and when it is set to 0, they become input pins. When the corresponding pin is set to the general I/O by PMR7, settings of PCR7 and PDR7 become valid.

PCR7 is an 8-bit write-only register. When PCR7 is read, 1 is read. When reset, PCR7 is initialized to H'00.

**Bit n**

PCR7n	Description
0	The P7n pin functions as an input pin (Initial value)
1	The P7n pin functions as an output pin

Note: n = 7 to 0

### (3) Port Data Register 7 (PDR7)

Bit :	7	6	5	4	3	2	1	0
	PDR77	PDR76	PDR75	PDR74	PDR73	PDR72	PDR71	PDR70
Initial value :	0	0	0	0	0	0	0	0
R/W :	R/W	R/W	R/W	R/W	R/W	R/W	R/W	R/W

Port data register 7 (PDR7) stores the data for the pins P77 to P70 of port 7.

When PCR7 is 1 (output), the PDR7 values are directly read if port 7 is read. Accordingly, the pin states are not affected. When PCR7 is 0 (input), the pin states are read if port 7 is read.

PDR7 is an 8-bit read/write enable register. When reset, PDR7 is initialized to H'00.

### 11.9.3 Pin Functions

This section describes the port 7 pin functions and their selection methods.

#### (1) P77/PPG7 to P70/PPG0

P77/PPG7 to P70/PPG0 are switched as shown below according to the PMR7n bit in PMR7 and the PCR7n bit in PCR7.

PMR7n	PCR7n	Pin Function
0	0	P7n input pin
	1	P7n output pin
1	*	PPGn input pin

Legend: \* Don't care.

Note: n = 7 to 0

### 11.9.4 Pin States

Table 11.25 shows the port 7 pin states in each operation mode.

**Table 11.25 Port 7 Pin States**

Pins	Reset	Active	Sleep	Standby	Watch	Subactive	Subsleep
P77/PPG7 to P70/PPG0	High-impedance	Operation	Holding	High-impedance	High-impedance	Operation	Holding

## 11.10 Port 8

### 11.10.1 Overview

Port 8 is an 8-bit I/O port. Table 11.26 shows the port 8 configuration.

Port 8 is a CMOS high-current I/O port. The sink current is 20 mA max. ( $V_{OL} = 1.5$  V) and up to four pins can simultaneously be set on.

Port 8 consists of pins that are used both as high-current I/O ports (P87 to P80) and servo monitor output (SV1, SV2), capstan external synchronous signal input (EXCAP), or external trigger signal input (EXTTRG). It is switched by port mode register 8 (PMR8) and port control register 8 (PCR8).

**Table 11.26 Port 8 Configuration**

Port	Function	Alternative Function
Port 8	P87 (high-current I/O port)	None
	P86 (high-current I/O port)	None
	P85 (high-current I/O port)	None
	P84 (high-current I/O port)	None
	P83 (high-current I/O port)	SV2 (servo monitor output)
	P82 (high-current I/O port)	SV1 (servo monitor output)
	P81 (high-current I/O port)	EXCAP (capstan external synchronous signal input)
	P80 (high-current I/O port)	EXTTRG (external trigger signal input)

### 11.10.2 Register Configuration

Table 11.27 shows the port 8 register configuration.

**Table 11.27 Port 8 Register Configuration**

Name	Abbrev.	R/W	Size	Initial Value	Address*
Port mode register 8	PMR8	R/W	Byte	H'F0	H'FFDF
Port control register 8	PCR8	W	Byte	H'00	H'FFD8
Port data register 8	PDR8	R/W	Byte	H'00	H'FFC8

Note: \* The address indicates the low-order 16 bits.

**(1) Port Mode Register 8 (PMR8)**

Bit :	7	6	5	4	3	2	1	0
	—	—	—	—	PMR83	PMR82	PMR81	PMR80
Initial value :	1	1	1	1	0	0	0	0
R/W :	—	—	—	—	R/W	R/W	R/W	R/W

Port mode register 8 (PMR8) controls switching of each pin function of port 8. The switching is specified in a unit of bit.

PMR8 is an 8-bit read/write enable register. When reset, PMR8 is initialized to H'F0.

If the EXCAP and EXTTRG input pins are set, the pin level need always be set to the high or low level regardless of the active mode and low power consumption mode. Note that the pin level must not reach an intermediate level.

**Bits 7 to 4—Reserved:** When the bits are read, 1 is always read. The write operation is valid.

**Bit 3—P83/SV2 Pin Switching (PMR83):** PMR83 sets whether the P83/SV2 pin is used as a P83 I/O pin or an SV2 pin for the servo monitor output. For the selection of the SV2 output, see section 28, Servo Circuits.

**Bit 3**

PMR83	Description
0	The P83/SV2 pin functions as a P83 I/O pin (Initial value)
1	The P83/SV2 pin functions as an SV2 output pin

**Bit 2—P82/SV1 Pin Switching (PMR82):** PMR82 sets whether the P82/SV1 pin is used as a P82 I/O pin or an SV1 pin for the servo monitor output. For the selection of the SV1 output, see section 28, Servo Circuits.

**Bit 2**

PMR82	Description
0	The P82/SV1 pin functions as a P82 I/O pin (Initial value)
1	The P82/SV1 pin functions as an SV1 output pin

**Bit 1—P81/EXCAP Pin Switching (PMR81):** PMR81 sets whether the P81/EXCAP pin is used as a P81 I/O pin or an EXCAP pin for the capstan external synchronous signal input.

**Bit 1**

PMR81	Description
0	The P81/EXCAP pin functions as a P81 I/O pin (Initial value)
1	The P81/EXCAP pin functions as an EXCAP input pin

**Bit 0—P80/EXTTRG Pin Switching (PMR80):** PMR80 sets whether the P80/EXTTRG pin is used as a P80 I/O pin or an EXTTRG pin for the external trigger signal input.

**Bit 0**

PMR80	Description
0	The P80/EXTTRG pin functions as a P80 I/O pin (Initial value)
1	The P80/EXTTRG pin functions as an EXTTRG input pin

**(2) Port Control Register 8 (PCR8)**

Bit :	7	6	5	4	3	2	1	0
	PCR87	PCR86	PCR85	PCR84	PCR83	PCR82	PCR81	PCR80
Initial value :	0	0	0	0	0	0	0	0
R/W :	W	W	W	W	W	W	W	W

Port control register 8 (PCR8) controls the I/Os of pins P87 to P80 of port 8 in a unit of bit. When PCR8 is set to 1, the corresponding P87 to P80 pins become output pins, and when it is set to 0, they become input pins. When the corresponding pin is set to a general I/O, settings of PCR8 and PDR8 become valid.

PCR8 is an 8-bit write-only register. When PCR8 is read, 1 is read. When reset, PCR8 is initialized to H'00.

**Bit n**

PCR8n	Description
0	The P8n pin functions as an input pin (Initial value)
1	The P8n pin functions as an output pin

Note: n = 7 to 0



### (3) Port Data Register 8 (PDR8)

Bit :	7	6	5	4	3	2	1	0
	PDR87	PDR86	PDR85	PDR84	PDR83	PDR82	PDR81	PDR80
Initial value :	0	0	0	0	0	0	0	0
R/W :	R/W	R/W	R/W	R/W	R/W	R/W	R/W	R/W

Port data register 8 (PDR8) stores the data for the pins P87 to P80 of port 8.

When PCR8 is 1 (output), the PDR8 values are directly read if port 8 is read. Accordingly, the pin states are not affected. When PCR8 is 0 (input), the pin states are read if port 8 is read.

PDR8 is an 8-bit read/write enable register. When reset, PDR8 is initialized to H'00.

#### 11.10.3 Pin Functions

This section describes the port 8 pin functions and their selection methods.

##### (1) P87 to P84

P87 to P84 are switched as shown below according to the PCR8n bit in PCR8.

PCR8n	Pin Function
0	P8n input pin
1	P8n output pin

Legend: \* Don't care.

Note: n = 7 to 4

##### (2) P83/SV2

P83/SV2 is switched as shown below according to the PMR83 bit in PMR8 and the PCR83 bit in PCR8.

PMR83	PCR83	Pin Function
0	0	P83 input pin
	1	P83n output pin
1	*	SV2 output pin

Legend: \* Don't care.

## (3) P82/SV1

P82/SV1 is switched as shown below according to the PMR82 bit in PRM8 and the PCR82 bit in PCR8.

<b>PMR82</b>	<b>PCR82</b>	<b>Pin Function</b>
0	0	P82 input pin
	1	P82 output pin
1	*	SV1 output pin

Legend: \* Don't care.

## (4) P81/EXCAP

P81/EXCAP is switched as shown below according to the PMR81 bit in PRM8 and the PCR81 bit in PCR8.

<b>PMR81</b>	<b>PCR81</b>	<b>Pin Function</b>
0	0	P81 input pin
	1	P81 output pin
1	*	EXCAP input pin

Legend: \* Don't care.

## (5) P80/EXTTRG

P80/EXTTRG is switched as shown below according to the PMR80 bit in PRM8 and the PCR80 bit in PCR8.

<b>PMR80</b>	<b>PCR80</b>	<b>Pin Function</b>
0	0	P80 input pin
	1	P80 output pin
1	*	EXTTRG input pin

Legend: \* Don't care.

### 11.10.4 Pin States

Table 11.28 shows the port 8 pin states in each operation mode.

**Table 11.28 Port 8 Pin States**

<b>Pins</b>	<b>Reset</b>	<b>Active</b>	<b>Sleep</b>	<b>Standby</b>	<b>Watch</b>	<b>Subactive</b>	<b>Subsleep</b>
P87 to P84 P83/SV2 P83/SV1 P81/EXCAP P80/EXTTRG	High-impedance	Operation	Holding	High-impedance	High-impedance	Operation	Holding

Note: If the EXCAP and EXTTRG input pins are set, the pin level need always be set to the high or low level regardless of the active mode and low power consumption mode. Note that the pin level must not reach an intermediate level.



## Section 12 Timer A

### 12.1 Overview

The Timer A is an 8-bit interval timer. It can be used as a clock timer when connected to a 32.768-kHz crystal oscillator.

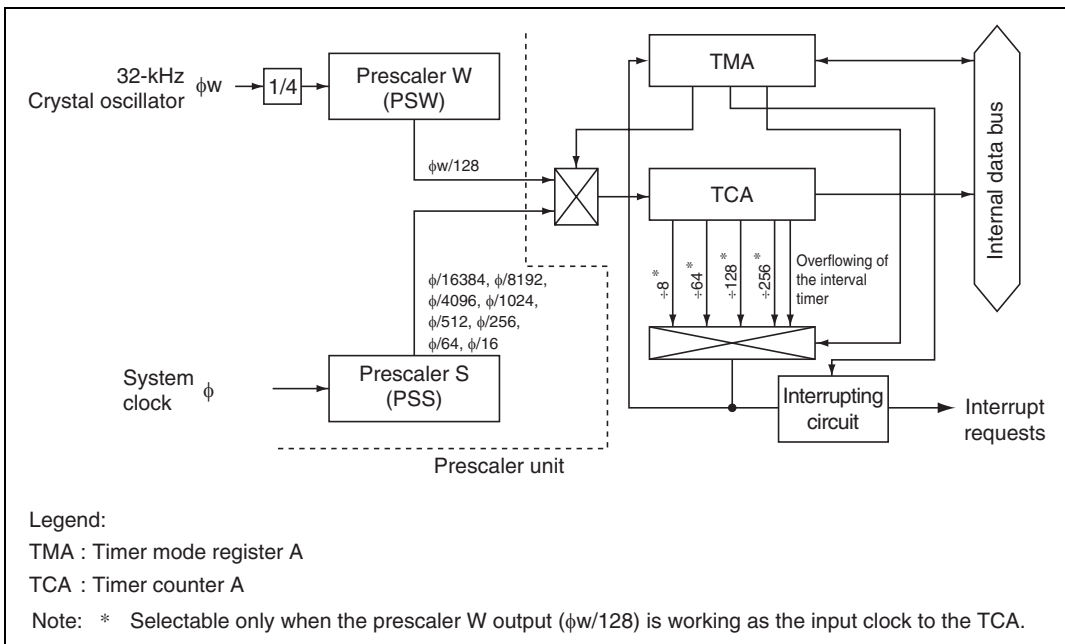
#### 12.1.1 Features

Features of the Timer A are as follows:

- Choices of eight different types of internal clocks ( $\phi/16384$ ,  $\phi/8192$ ,  $\phi/4096$ ,  $\phi/1024$ ,  $\phi/512$ ,  $\phi/256$ ,  $\phi/64$ , and  $\phi/16$ ) are available for your selection.
- Four different overflowing cycles (1 s, 0.5 s, 0.25 s, and 0.03125 s) are selectable as a clock timer. (When using a 32.768-kHz crystal oscillator.)
- Requests for interrupt will be output when the counter overflows.

### 12.1.2 Block Diagram

Figure 12.1 shows a block diagram of the Timer A.



**Figure 12.1 Block Diagram of the Timer A**

### 12.1.3 Register Configuration

Table 12.1 shows the register configuration of the Timer A.

**Table 12.1 Register Configuration**

Name	Abbrev.	R/W	Size	Initial Value	Address*
Timer mode register A	TMA	R/W	Byte	H'30	H'FFBA
Timer counter A	TCA	R	Byte	H'00	H'FFBB

Note: \* Lower 16 bits of the address.

## 12.2 Descriptions of Respective Registers

### 12.2.1 Timer Mode Register A (TMA)

Bit :	7	6	5	4	3	2	1	0
	TMAOV	TMAIE	—	—	TMA3	TMA2	TMA1	TMA0
Initial value :	0	0	1	1	0	0	0	0
R/W :	R/(W)*	R/W	—	—	R/W	R/W	R/W	R/W

Note: \* Only 0 can be written to clear the flag.

The timer mode register A (TMA) works to control the interrupts of the Timer A and to select the input clock.

TMA is an 8-bit read/write register. When reset, the TMA will be initialized to H'30.

**Bit 7—Timer A Overflow Flag (TMAOV):** This is a status flag indicating the fact that the TCA is overflowing (H'FF → H'00).

#### Bit 7

TMAOV	Description
0	[Clearing condition] (Initial value) When 0 is written to the TMAOV flag after reading the TMAOV flag under the status where TMAOV = 1
1	[Setting condition] When the TCA overflows

**Bit 6—Enabling Interrupt of the Timer A (TMAIE):** This bit works to permit/prohibit occurrence of interrupt of the Timer A (TMAI) when the TCA overflows and when the TMAOV of the TMA is set to 1.

#### Bit 6

TMAIE	Description
0	Prohibits occurrence of interrupt of the Timer A (TMAI) (Initial value)
1	Permits occurrence of interrupt of the Timer A (TMAI)

**Bits 5 and 4—Reserved:** When they are read, 1 will always be readout. Writes are disabled.

**Bit 3—Selection of the Clock Source and Prescaler (TMA3):** This bit works to select the PSS or PSW as the clock source for the Timer A.

**Bit 3**

TMA3	Description
0	Selects the PSS as the clock source for the Timer A (Initial value)
1	Selects the PSW as the clock source for the Timer A

**Bits 2 to 0—Clock Selection (TMA2 to TMA0):** These bits work to select the clock to input to the TCA. In combination with the TMA3 bit, the choices are as follows:

Bit 3 TMA3	Bit 2 TMA2	Bit 1 TMA1	Bit 0 TMA0	Prescaler Division Ratio (Interval Timer) or Overflow Cycle (Time Base)	Operation Mode		
0	0	0	0	PSS, $\phi/16384$ (Initial value)	Interval timer mode		
			1	PSS, $\phi/8192$			
		1	0	PSS, $\phi/4096$			
			1	PSS, $\phi/1024$			
	1	0	0	0	PSS, $\phi/512$		
				1	PSS, $\phi/256$		
			1	0	PSS, $\phi/64$		
				1	PSS, $\phi/16$		
		1	0	0	0	1 s	Clock time base mode
					1	0.5 s	
				1	0	0.25 s	
					1	0.03125 s	
1	0	0	Works to clear the PSW and TCA to H'00				
		1					
		1	0				
			1				

Note:  $\phi = f_{osc}$



### 12.2.2 Timer Counter A (TCA)

Bit :	7	6	5	4	3	2	1	0
	TCA7	TCA6	TCA5	TCA4	TCA3	TCA2	TCA1	TCA0
Initial value :	0	0	0	0	0	0	0	0
R/W :	R	R	R	R	R	R	R	R

The timer counter A (TCA) is an 8-bit up-counter which counts up on inputs from the internal clock. The inputting clock can be selected by TMA3 to TMA0 bits of the TMA.

When the TCA overflows, the TMAOV bit of the TMA is set to 1.

The TCA can be cleared by setting the TMA3 and TMA2 bits of the TMA to 11.

The TCA is always readable. When reset, the TCA will be initialized into H'00.

### 12.2.3 Module Stop Control Register (MSTPCR)

	MSTPCRH								MSTPCRL							
Bit :	7	6	5	4	3	2	1	0	7	6	5	4	3	2	1	0
	MSTP15	MSTP14	MSTP13	MSTP12	MSTP11	MSTP10	MSTP9	MSTP8	MSTP7	MSTP6	MSTP5	MSTP4	MSTP3	MSTP2	MSTP1	MSTP0
Initial value :	1	1	1	1	1	1	1	1	1	1	1	1	1	1	1	1
R/W :	R/W	R/W	R/W	R/W	R/W	R/W	R/W	R/W	R/W	R/W	R/W	R/W	R/W	R/W	R/W	R/W

The MSTPCR are 8-bit read/write twin registers which work to control the module stop mode.

When the MSTP15 bit is set to 1, the Timer A stops its operation at the ending point of the bus cycle to shift to the module stop mode. For more information, see section 4.5, Module Stop Mode.

When reset, the MSTPCR will be initialized into H'FFFF.

**Bit 7—Module Stop (MSTP15):** This bit works to designate the module stop mode for the Timer A.

#### MSTPCRH

##### Bit 7

MSTP15	Description
0	Cancels the module stop mode of the Timer A
1	Sets the module stop mode of the Timer A (Initial value)

## 12.3 Operation

The Timer A is an 8-bit timer for use as an interval timer and as a clock time base connecting to a 32.768 kHz crystal oscillator.

### 12.3.1 Operation as the Interval Timer

When the TMA3 bit of the TMA is cleared to 0, the Timer A works as an 8-bit interval timer.

When reset since the TCA is cleared to H'00 and as the TMA3 bit is cleared to 0, the Timer A continues counting up as the interval counter without interrupts right after resetting.

As the operation clock for the Timer A, selection can be made from eight different types of internal clocks being output from the PSS by the TMA2 to TMA0 bits of the TMA.

When the clock signal is input after the reading of the TCA reaches H'FF, the Timer A overflows and the TMAOV bit of the TMA will be set to 1. At this time, when the TMAIE bit of the TMA is 1, interrupt occurs.

When overflowing occurs, the reading of the TCA returns to H'00 before resuming counting up. Consequently, it works as the interval timer to produce overflow outputs periodically at every 256 input clocks.

### 12.3.2 Operation of the Timer for Clocks

When the TMA3 bit of the TMA is set to 1, the Timer A works as a time base for the clock.

As the overflow cycles for the Timer A, selection can be made from four different types by counting the clock being output from the PSW by the TMA1 bit and TMA0 bit of the TMA.

### 12.3.3 Initializing the Counts

When the TMA3 and TMA2 bits are set to 11, the PSW and TCA will be cleared to H'00 to come to a stop.

At this state, writing 10 to the TMA3 bit and TMA2 bit makes the Timer A to start counting from H'00 under the time base mode for clocks.

After clearing the PSW and TCA using the TMA3 and TMA2 bits, writing 00 or 01 to the TMA3 bit and TMA2 bit work to make the Timer A to start counting from H'00 under the interval timer mode. However, since the PSS is not cleared, the period to the first count is not constant.

## Section 13 Timer B

### 13.1 Overview

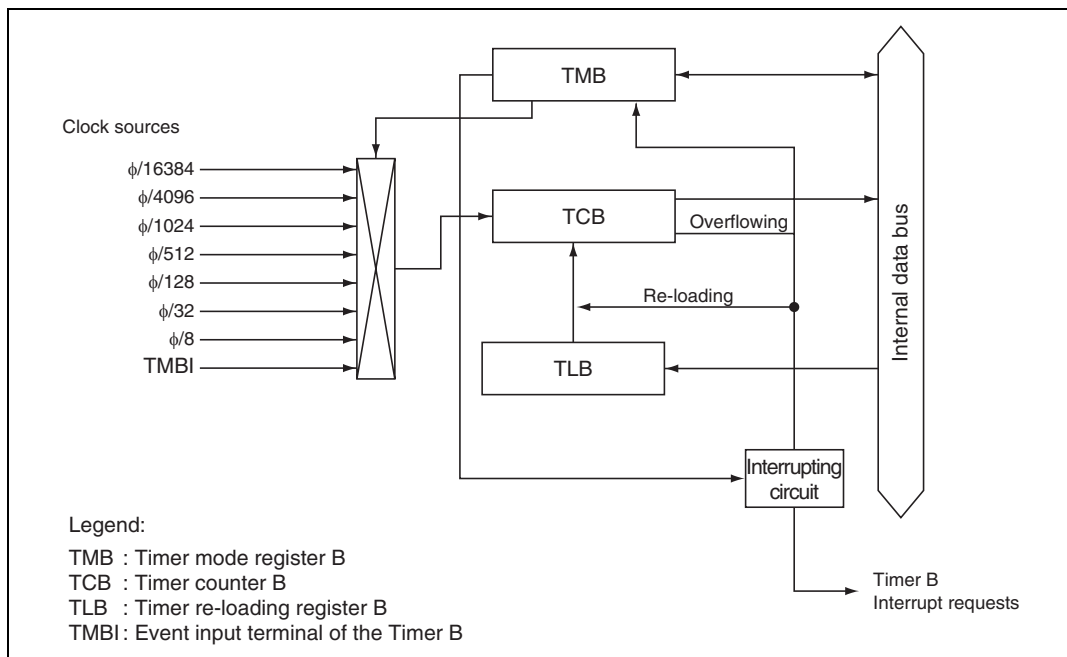
The Timer B is an 8-bit up-counter. The Timer B is equipped with two different types of functions namely, the interval function and the auto reloading function.

#### 13.1.1 Features

- Selection from choices of seven different types of internal clocks ( $\phi/16384$ ,  $\phi/4096$ ,  $\phi/1024$ ,  $\phi/512$ ,  $\phi/128$ ,  $\phi/32$ , and  $\phi/8$ ) or selection of external clock are possible.
- When the counter overflows, an interrupt request will be issued.

#### 13.1.2 Block Diagram

Figure 13.1 shows a block diagram of the Timer B.



**Figure 13.1 Block diagram of the Timer B**

### 13.1.3 Pin Configuration

Table 13.1 shows the pin configuration of the Timer B.

**Table 13.1 Pin Configuration**

Name	Abbrev.	I/O	Function
Event inputs to the Timer B	TMBI	Input	Event input pin for inputs to the TCB

### 13.1.4 Register Configuration

Table 13.2 shows the register configuration of the Timer B.

The TCB and TLB are being allocated to the same address. Reading or writing determines the accessing register.

**Table 13.2 Register Configuration**

Name	Abbrev.	R/W	Size	Initial Value	Address*
Timer mode register B	TMB	R/W	Byte	H'18	H'D110
Timer counter B	TCB	R	Byte	H'00	H'D111
Timer load register B	TLB	W	Byte	H'00	H'D111
Port mode register 5	PMR5	R/W	Byte	H'F1	H'FFDC

Note: \* Lower 16 bits of the address.

## 13.2 Descriptions of Respective Registers

### 13.2.1 Timer Mode Register B (TMB)

Bit :	7	6	5	4	3	2	1	0
	TMB17	TMBIF	TMBIE	—	—	TMB12	TMB11	TMB10

Initial value :    0        0        0        1        1        0        0        0

R/W :    R/W    R/(W)\*    R/W    —        —        R/W    R/W    R/W

Note: \* Only 0 can be written to clear the flag.

The TMB is an 8-bit read/write register which works to control the interrupts, to select the auto reloading function and to select the input clock.

When reset, the TMB is initialized to H'18.

**Bit 7—Selecting the Auto Reloading Function (TMB17):** This bit works to select the auto reloading function of the Timer B.

#### Bit 7

TMB17	Description
0	Selects the interval function (Initial value)
1	Selects the auto reloading function

**Bit 6—Interrupt Requesting Flag for the Timer B (TMBIF):** This is an interrupt requesting flag for the Timer B. It indicates the fact that the TCB is overflowing.

#### Bit 6

TMBIF	Description
0	[Clearing condition] (Initial value) When 0 is written after reading 1
1	[Setting condition] When the TCB overflows

**Bit 5—Enabling Interrupt of the Timer B (TMBIE):** This bit works to permit/prohibit occurrence of interrupt of the Timer B when the TCB overflows and when the TMBIF is set to 1.

**Bit 5**

TMBIE	Description
0	Prohibits occurrence of interrupt of the Timer B (Initial value)
1	Permits occurrence of interrupt of the Timer B

**Bits 4 and 3—Reserved:** When they are read, 1 will always be readout. Writes are disabled.

**Bits 2 to 0—Clock Selection (TMB12 to TMB10):** These bits work to select the clock to input to the TCB. Selection of the rising edge or the falling edge is workable with the external event inputs.

Bit 2	Bit 1	Bit 0	Descriptions
TMB12	TMB11	TMB10	
0	0	0	Internal clock: Counts at $\phi/16384$ (Initial value)
0	0	1	Internal clock: Counts at $\phi/4096$
0	1	0	Internal clock: Counts at $\phi/1024$
0	1	1	Internal clock: Counts at $\phi/512$
1	0	0	Internal clock: Counts at $\phi/128$
1	0	1	Internal clock: Counts at $\phi/32$
1	1	0	Internal clock: Counts at $\phi/8$
1	1	1	Counts at the rising edge and the falling edge of external event inputs (TMBI)*

Note: \* The edge selection for the external event inputs is made by setting the PMR51 of the port mode register 5 (PMR5). See section 13.2.4, Port Mode Register 5 (PMR5).

### 13.2.2 Timer Counter B (TCB)

Bit :	7	6	5	4	3	2	1	0
	TCB17	TCB16	TCB15	TCB14	TCB13	TCB12	TCB11	TCB10
Initial value :	0	0	0	0	0	0	0	0
R/W :	R	R	R	R	R	R	R	R

The TCB is an 8-bit readable register which works to count up by the internal clock inputs and external event inputs. The input clock can be selected by the TMB12 to TMB10 of the TMB. When the TCB overflows (H'FF → H'00 or H'FF → TLB setting), a interrupt request of the Timer B will be issued.

When reset, the TCB is initialized to H'00.

### 13.2.3 Timer Load Register B (TLB)

Bit :	7	6	5	4	3	2	1	0
	TLB17	TLB16	TLB15	TLB14	TLB13	TLB12	TLB11	TLB10
Initial value :	0	0	0	0	0	0	0	0
R/W :	W	W	W	W	W	W	W	W

The TLB is an 8-bit write only register which works to set the reloading value of the TCB. When the reloading value is set to the TLB, the value will be simultaneously loaded to the TCB and the TCB starts counting up from the set value. Also, during an auto reloading operation, when the TCB overflows, the value of the TLB will be loaded to the TCB. Consequently, the overflowing cycle can be set within the range of 1 to 256 input clocks.

When reset, the TLB is initialized to H'00.

### 13.2.4 Port Mode Register 5 (PMR5)

Bit :	7	6	5	4	3	2	1	0
	—	—	—	—	PMR53	PMR52	PMR51	—
Initial value :	1	1	1	1	0	0	0	1
R/W :	—	—	—	—	R/W	R/W	R/W	—

The port mode register 5 (PMR5) works to changeover the pin functions of the port 5 and to designate the edge sense of the event inputs of the Timer B (TMBI).

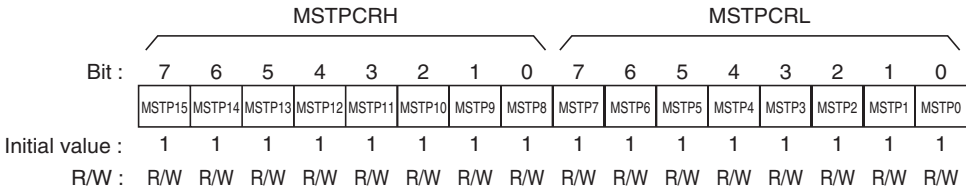
The PMR5 is an 8-bit read/write register. When reset, the PMR5 will be initialized to H'F1.

See section 11.7, Port 5 for other information than bit 1.

**Bit 1—Selecting the Edges of the Event Inputs to the Timer B (PMR51):** This bit works to select the input edge sense of the TMBI pins.

**Bit 1**

PMR51	Description
0	Detects the falling edge of the event inputs to the Timer B (Initial value)
1	Detects the rising edge of the event inputs to the Timer B

**13.2.5 Module Stop Control Register (MSTPCR)**

The MSTPCR are 8-bit read/write twin registers which work to control the module stop mode. When the MSTP14 bit is set to 1, the Timer B stops its operation at the ending point of the bus cycle to shift to the module stop mode. For more information, see section 4.5, Module stop mode. When reset, the MSTPCR is initialized to H'FFFF.

**Bit 6—Module Stop (MSTP14):** This bit works to designate the module stop mode for the Timer B.

**MSTPCRH****Bit 6**

MSTP14	Description
0	Cancels the module stop mode of the Timer B
1	Sets the module stop mode of the Timer B (Initial value)



## 13.3 Operation

### 13.3.1 Operation as the Interval Timer

When the TMB17 bit of the TMB is set to 0, the Timer B works as an 8-bit interval timer.

When reset, since the TCB is cleared to H'00 and as the TMB17 bit is cleared to 0, the Timer B continues counting up as the interval timer without interrupts right after resetting.

As the clock source for the Timer B, selection can be made from seven different types of internal clocks being output from the prescaler unit by the TMB12 to TMB10 bits of the TMB or an external clock through the TMBI input pin can be chosen instead.

When the clock signal is input after the reading of the TCB reaches H'FF, the Timer B overflows and the TMBIF bit of the TMB will be set to 1. At this time, when the TMBIE bit of the TMB is 1, interrupt occurs.

When overflowing occurs, the reading of the TCB returns to H'00 before resuming counting up.

When a value is set to the TLB while the interval timer is in operation, the value which has been set to the TLB will be loaded to the TCB simultaneously.

### 13.3.2 Operation as the Auto Reload Timer

When the TMB17 of the TMB is set to 1, the Timer B works as an 8-bit auto reload timer.

When a reload value is set in the TLB, the value is loaded onto the TCB at the same time, and the TCB starts counting up from the value.

When the clock signal is input after the reading of the TCB reaches H'FF, the Timer B overflows and the TLB value is loaded onto the TCB, then the TCB continues counting up from the loaded value. Accordingly, overflow interval can be set within the range of 1 to 256 clocks depending on the TLB value.

Clock source and interrupts in the auto reload operation are the same as those in the interval operation. When the TLB value is re-set while the auto reload timer is in operation, the value which has been set to the TLB will be loaded onto the TCB simultaneously.

### 13.3.3 Event Counter

The Timer B works as an event counter using the TMBI pin as the event input pin. When the TMB12 to TMB10 are set to 111, the external event will be selected as the clock source and the TCB counts up at the leading edge or the trailing edge of the TMBI pin inputs.



---

## Section 14 Timer J

### 14.1 Overview

The Timer J consists of twin 8-bit counters. It carries seven different operation modes such as reloading and event counting.

#### 14.1.1 Features

The Timer J consists of twin 8-bit reloading timers and it is usable under the various functions as follows:

- Twin 8-bit reloading timers (Among the two, one is capable to make timer outputs)
- Twin 8-bit event counters (Capable to make reloading)
- 8-bit event counter (Capable to make reloading) + 8-bit reload timer
- 16-bit event counter (Capable to make 16-bit reloading)
- 16-bit reload timer (Capable to make 16-bit reloading)
- Remote controlled transmissions
- "Take up/Supply reel pulse" dividing ( $8 \text{ bit} \times 2 \text{ units}$ )

#### 14.1.2 Block Diagram

Figure 14.1 is a block diagram of the Timer J. The Timer J consists of two reload timers namely, TMJ-1 and TMJ-2.

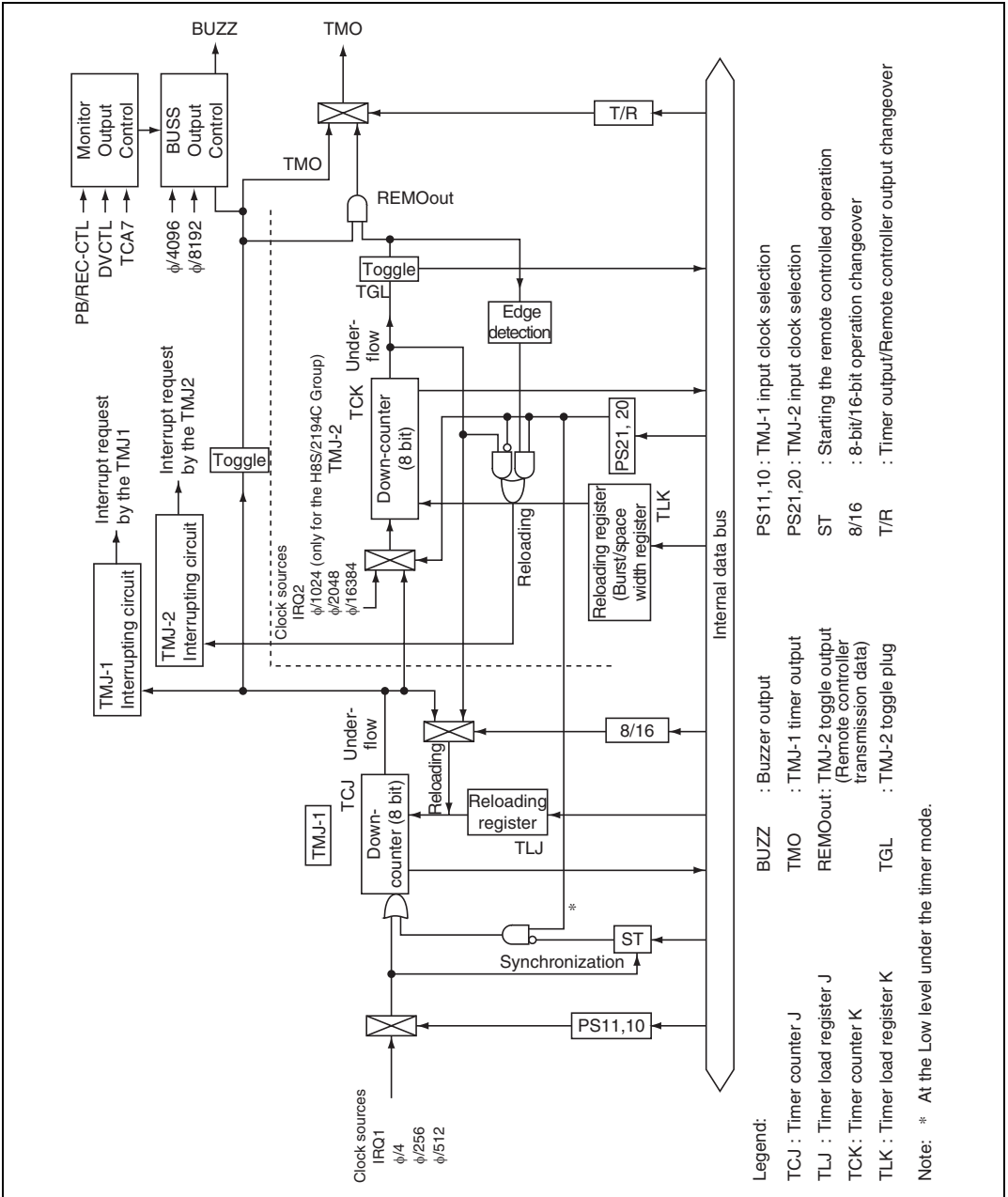


Figure 14.1 Block Diagram of the Timer J

### 14.1.3 Pin Configuration

Table 14.1 shows the pin configuration of the Timer J.

**Table 14.1 Pin Configuration**

Name	Abbrev.	I/O	Function
Event input pin	$\overline{\text{IRQ1}}$	Input	Event inputs to the TMJ-1
Event input pin	$\overline{\text{IRQ2}}$	Input	Event inputs to the TMJ-2

### 14.1.4 Register Configuration

Table 14.2 shows the register configuration of the Timer J.

The TCJ and TLJ or the TCK and TLK are being allocated to the same address respectively. Reading or writing determines the accessing register.

**Table 14.2 Register Configuration**

Name	Abbrev.	R/W	Size	Initial Value	Address <sup>*2</sup>
Timer mode register J	TMJ	R/W	Byte	H'00	H'D13A
Timer J control register	TMJC	R/W	Byte	H'09	H'D13B
Timer J status register	TMJS	R/(W) <sup>*1</sup>	Byte	H'3F	H'D13C
Timer counter J	TCJ	R	Byte	H'FF	H'D139
Timer counter K	TCK	R	Byte	H'FF	H'D138
Timer load register J	TLJ	W	Byte	H'FF	H'D139
Timer load register K	TLK	W	Byte	H'FF	H'D138

Notes: 1. Only 0 can be written to clear the flag.  
2. Lower 16 bits of the address.

## 14.2 Descriptions of Respective Registers

### 14.2.1 Timer Mode Register J (TMJ)

Bit :	7	6	5	4	3	2	1	0
	PS11	PS10	ST	8/16	PS21	PS20	TGL	T/R
Initial value :	0	0	0	0	0	0	0	0
R/W :	R/W	R/W	R/W	R/W	R/W	R/W	R	R/W

The timer mode register J (TMJ) works to select the inputting clock for the TMJ-1 and TMJ-2 and to set the operation mode.

The TMJ is an 8-bit register and Bit-1 is for read only and all the remaining bits are applicable to read/write.

When reset, the TMJ is initialized to H'00.

Under all other modes than the remote controlling mode, writing into the TMJ works to initialize the counters (TCJ and TCK) to H'FF.

**Bits 7 and 6—Selecting the Inputting Clock to the TMJ-1 (PS11 and PS10):** These bits work to select the clock to input to the TMJ-1. Selection of the rising edge or the falling edge is workable for counting by use of an external clock.

Bit 7	Bit 6	Description
PS11	PS10	
0	0	Counting by the PSS, $\phi/512$ (Initial value)
	1	Counting by the PSS, $\phi/256$
1	0	Counting by the PSS, $\phi/4$
	1	Counting at the rising edge or the falling edge of the external clock inputs (IRQ1)*

Note: \* The edge selection for the external clock inputs is made by setting the edge select register (IEGR). See section 6.2.4, IRQ Edge Select Registers (IEGR) for more information.

When using an external clock under the remote controlling mode, set the opposite edge with the IRQ1 and the IRQ2 when using an external clock under the remote controlling mode. (When IRQ1 falling, select IRQ2 rising and when IRQ1 rising, select IRQ2 falling.)

**Bit 5—Starting the Remote Controlled Operation (ST):** This bit works to start the remote controlled operations.

When this bit is set to 1, clock signal is supplied to the TMJ-1 to start signal transmissions.

When this bit is cleared to 0, clock supply stops to discontinue the operation. The ST bit will be valid under the remote controlling mode, namely, when the Bit 0 (T/R bit) is 1 and the Bit 4 (8-/16-bit) is 0.

Under other modes than the remote controlling mode, it will be fixed to 0. When a shift to the low power consumption mode is made during remote controlled operation, the ST bit will be cleared to 0. When resuming operation after returning to the active mode, write 1.

#### Bit 5

ST	Description
0	Works to stop clock signal supply to the TMJ-1 under the remote controlling mode (Initial value)
1	Works to supply clock signal to the TMJ-1 under the remote controlling mode

**Bit 4—Switching Over Between 8-bit/16-bit Operations (8/16):** This bit works to choose if using the Timer J as two units of 8-bit timer/counter or if using it as a single unit of 16-bit timer/counter. Even under 16-bit operations, TMJ1I interrupt requests from the TMJ-1 will be valid.

#### Bit 4

8/16	Description
0	Makes the TMJ-1 and TMJ-2 operate separately (Initial value)
1	Makes the TMJ-1 and TMJ-2 operate altogether as 16-bit timer/counter

**Bits 3 and 2—Selecting the Inputting Clock to the TMJ-2 (PS21 and PS20):** This bit works to select the clock to input to the TMJ-2. Selection of the leading edge or the trailing edge is workable for counting by use of an external clock.

TMJC: Bit 0 Bit 3		Bit 2	Description
PS22 <sup>*3</sup>	PS21	PS20	
1	0	0	Counting by the PSS, $\phi/16384$ (Initial value)
		1	Counting by the PSS, $\phi/2048$
	1	0	Counting at underflowing of the TMJ-1
		1	Counting at the leading edge or the trailing edge of the external clock inputs (IRQ2) <sup>*1</sup>
0	<sup>*2</sup>	<sup>*2</sup>	Counting by the PSS, $\phi/1024$ (available only the H8S/2194C Group)

- Notes: 1. The edge selection for the external clock inputs is made by setting the edge select register (IEGR). See section 6.2.4, IRQ Edge Select Registers (IEGR) for more information.
2. Don't care.
3. Available only in the H8S/2194C Group.

**Bit 1—TMJ-2 Toggle Flag (TGL):** This flag indicates the toggled status of the underflowing with the TMJ-2. Reading only is workable. It will be cleared to 0 under the low power consumption mode.

#### Bit 1

TGL	Description
0	The toggle output of the TMJ-2 is 0 (Initial value)
1	The toggle output of the TMJ-2 is 0

**Bit 0—Switching Over between Timer Output/Remote Controlling Output (T/R):** This bit works to select if using the timer outputs from the TMJ-1 as the output signal through the TMO pin or if using the toggle outputs (remote controlled transmission data) from the TMJ-2 as the output signal through the TMO pin.

#### Bit 0

T/R	Description
0	Timer outputs from the TMJ-1 (Initial value)
1	Toggle outputs from the TMJ-2 (remote controlled transmission data)



**Selecting the Operation Mode:** The operation mode of the Timer J is determined by the Bit 4 (8/16) and Bit 0 (T/R) of the TMJ.

### TMJ

Bit 4	Bit 0	Description
8/16	T/R	
0	0	8-bit timer × 2 (Initial value)
	1	Remote controlling mode
1	*	16-bit timer

Legend: \* Don't care.

When writing is made into the TMJ under the timer mode, the counters (TCJ and TCK) will be initialized (H'FF). Consequently, writing into the reloading registers (TLJ and TLK) should be conducted after finishing settings with the TMJ.

Under the remote controlling mode, although the TLJ and the TLK will not be initialized even when writing is made into the TMJ, follow the sequence listed below when starting a remote controlling operation.

- (1) Make setting to the remote controlling mode with the TMJ.
- (2) Write the data into the TLJ and TLK.
- (3) Start the remote controlled operation by use of the TMJ. (ST bit = 1)

Even under 16-bit operations, TMJ1I interrupt requests from the TMJ-1 will be valid.

#### 14.2.2 Timer J Control Register (TMJC)

Bit :	7	6	5	4	3	2	1	0
	BUZZ1	BUZZ0	MON1	MON0	—	TMJ2IE	TMJ1IE	(PS22)*
Initial value :	0	0	0	0	1	0	0	1
R/W :	R/W	R/W	R/W	R/W	—	R/W	R/W	(R/W)*

Note: \* Bit 0 is readable/writable only in the H8S/2194C Group.

The timer J control register works to select the buzzer output frequency and to control permission/prohibition of interrupts.

The TMJC is an 8-bit read/write register.

When reset, the TMJC is initialized to H'09.

**Bits 7 and 6—Selecting the Buzzer Output (BUZZ1 or BUZZ0):** This bit works to select if using the buzzer outputs as the output signal through the BUZZ pin or if using the monitor signals as the output signal through the BUZZ pin.

When setting is made to the monitor signals, choose the monitor signal using the MON1 bit and MON0 bit.

Bit 7	Bit 6		Frequency when $\phi = 10$ MHz
BUZZ1	BUZZ0	Description	
0	0	$\phi/4096$	(Initial value) 2.44 kHz
	1	$\phi/8192$	1.22 kHz
1	0	Works to output monitor signals	
	1	Works to output BUZZ signals from the Timer J	

**Bits 5 and 4—Selecting the Monitor Signals (MON1 or MON0):** These bits work to select the type of signals being output through the BUZZ pin for monitoring purpose. These settings are valid only when the BUZZ1 and BUZZ0 bits are being set to 1 and 0.

When PB-CTL or REC-CTL is chosen, signal duties will be output as they are.

In case of DVCTL signals, signals from the CTL dividing circuit will be toggled before being output. Signal waveforms divided by the CTL dividing circuit into "n-divisions" will further be divided into halves. (Namely, "2n" divisions, 50% duty waveform).

In case of TCA7, Bit 7 of the counter of the Timer A will be output. (50% duty)

When the prescaler is being used with the Timer A, 1 Hz outputs are available.

Bit 5	Bit 4	Description	
MON1	MON0		
0	0	PB or REC-CTL	(Initial value)
	1	DVCTL	
1	*	Outputs TCA7	

Legend: \* Don't care.

**Bit 3—Reserved:** When this is read, 1 will always be readout. Writes are disabled.

**Bit 2—Enabling Interrupt of the TMJ2I (TMJ2IE):** This bit works to permit/prohibit occurrence of TMJ2I interrupt of the TMJS in 1-set of the TMJ2I.

Bit 2	Description	
TMJ2IE		
0	Prohibits occurrence of TMJ2I interrupt	(Initial value)
1	Permits occurrence of TMJ2I interrupt	

**Bit 1—Enabling Interrupt of the TMJ1I (TMJ1IE):** This bit works to permit/prohibit occurrence of TMJ1I interrupt of the TMJS in 1-set of the TMJ1I.

**Bit 1**

TMJ1IE	Description
0	Prohibits occurrence of TMJ1I interrupt (Initial value)
1	Permits occurrence of TMJ1I interrupt

**Bit 0—Reserved (for H8S/2194 Group):** When this is read, 1 will always be readout. Writes are disabled.

**Bit 0—Selecting the Input clock for TMJ-2 (PS22) (for H8S/2194C Group):** This bit, together with bits 3 and 2 (PS21, PS20) in TMJ, selects the input clock for TMJ-2. For details, see section 14.2.1, Timer Mode Register J (TMJ).

**14.2.3 Timer J Status Register (TMJS)**

Bit :	7	6	5	4	3	2	1	0
	TMJ2I	TMJ1I	—	—	—	—	—	—

Initial value : 0 0 1 1 1 1 1 1

R/W : R/(W)\* R/(W)\* — — — — —

Note: \* Only 0 can be written to clear the flag.

The timer J status register (TMJS) works to indicate issuance of the interrupt request of the Timer J. The TMJS is an 8-bit read/write register. When reset, the TMJS is initialized to H'3F.

**Bit 7—TMJ2I Interrupt Requesting Flag (TMJ2I):** This is the TMJ2I interrupt requesting flag. This flag is set when the TMJ-2 underflows.

**Bit 7**

TMJ2I	Description
0	[Clearing condition] (Initial value) When 0 is written after reading 1
1	[Setting condition] When the TMJ-2 underflows

**Bit 6—TMJ1I Interrupt Requesting Flag (TMJ1I):** This is the TMJ1I interrupt requesting flag. This flag is set out when the TMJ-1 underflows.

TMJ1I interrupt requests will also be made under a 16-bit operation.

#### Bit 6

TMJ1I	Description	
0	[Clearing condition] When 0 is written after reading 1	(Initial value)
1	[Setting condition] When the TMJ-1 underflows	

**Bits 5 to 0—Reserved:** When they are read, 1 will always be readout. Writes are disabled.

#### 14.2.4 Timer Counter J (TCJ)

Bit :	7	6	5	4	3	2	1	0
	TDR17	TDR16	TDR15	TDR14	TDR13	TDR12	TDR11	TDR10
Initial value :	1	1	1	1	1	1	1	1
R/W :	R	R	R	R	R	R	R	R

The time counter J (TCJ) is an 8-bit readable down-counter which works to count down by the internal clock inputs or external clock inputs. The inputting clock can be selected by the PS11 and PS10 bits of the TMJ. TCJ values can be readout always. Nonetheless, when the 8-/16-bit of the TMJ is being set to 1 (means when setting is made to 16-bit operation), reading is possible under the word command only.

At this time, the TCK of the TMJ-2 can be read by the upper 8 bits and the TCJ can be read by the lower 8 bits.

When the TCJ underflows (H'00 → Reloading value), regardless of the operation mode setting of the 8-/16-bit, the TMJ1I bit of the TMJS will be set to 1. The TCJ and TLJ are being allocated to the same address.

When reset, the TCJ is initialized to H'FF.

### 14.2.5 Timer Counter K (TCK)

Bit :	7	6	5	4	3	2	1	0
	TDR27	TDR26	TDR25	TDR24	TDR23	TDR22	TDR21	TDR20
Initial value :	1	1	1	1	1	1	1	1
R/W :	R	R	R	R	R	R	R	R

The time counter K (TCK) is an 8-bit readable down-counter which works to count down by the internal clock inputs or external clock inputs. The inputting clock can be selected by the PS21 and PS20 bits of the TMJ. TCK values can be readout always. Nonetheless, when the 8-/16-bit of the TMJ is being set to 1 (means when setting is made to 16-bit operation), reading is possible under the word command only.

At this time, the TCK can be read by the upper 8 bits and the TCJ of the TMJ-1 can be read by the lower 8 bits.

When the TCK underflows (H'00 → Reloading value), the TMJ2I bit of the TMJS will be set to 1. The TCK and TLK are being allocated to the same address.

When reset, the TCK is initialized to H'FF.

### 14.2.6 Timer Load Register J (TLJ)

Bit :	7	6	5	4	3	2	1	0
	TLR17	TLR16	TLR15	TLR14	TLR13	TLR12	TLR11	TLR10
Initial value :	1	1	1	1	1	1	1	1
R/W :	W	W	W	W	W	W	W	W

The timer load register J (TLJ) is an 8-bit write only register which works to set the reloading value of the TCJ.

When the reloading value is set to the TLJ, the value will be simultaneously loaded to the TCJ and the TCJ starts counting down from the set value. Also, during an auto reloading operation, when the TCJ underflows, the value of the TLJ will be loaded to the TCJ. Consequently, the underflowing cycle can be set within the range of 1 to 256 input clocks. Nonetheless, when the 8-/16-bit of the TMJ is being set to 1 (means when setting is made to 16-bit operation), writing is possible under the word command only.

At this time, the upper 8 bits can be written into the TLK of the TMJ-2 and the lower 8 bits can be written into the TLJ.

The TLJ and TCJ are being allocated to the same address.

When reset, the TLJ is initialized to H'FF.

### 14.2.7 Timer Load Register K (TLK)

Bit :	7	6	5	4	3	2	1	0
	TLR27	TLR26	TLR25	TLR24	TLR23	TLR22	TLR21	TLR20
Initial value :	1	1	1	1	1	1	1	1
R/W :	W	W	W	W	W	W	W	W

The timer load register K (TLK) is an 8-bit write only register which works to set the reloading value of the TCK.

When the reloading value is set to the TLK, the value will be simultaneously loaded to the TCK and the TCK starts counting down from the set value. Also, during an auto reloading operation, when the TCK underflows, the value of the TLK will be loaded to the TCK. Consequently, the underflowing cycle can be set within the range of 1 to 256 input clocks. Nonetheless, when the 8-/16-bit of the TMJ is being set to 1 (means when setting is made to 16-bit operation), writing is possible under the word command only. At this time, the upper 8 bits can be written into the TLK and the lower 8 bits can be written into the TLJ of the TMJ-1. The TLK and TCK are being allocated to the same address.

When reset, the TLK is initialized to H'FF.

### 14.2.8 Module Stop Control Register (MSTPCR)

	MSTPCRH								MSTPCRL							
Bit :	7	6	5	4	3	2	1	0	7	6	5	4	3	2	1	0
	MSTP15	MSTP14	MSTP13	MSTP12	MSTP11	MSTP10	MSTP9	MSTP8	MSTP7	MSTP6	MSTP5	MSTP4	MSTP3	MSTP2	MSTP1	MSTP0
Initial value :	1	1	1	1	1	1	1	1	1	1	1	1	1	1	1	1
R/W :	R/W	R/W	R/W	R/W	R/W	R/W	R/W	R/W	R/W	R/W	R/W	R/W	R/W	R/W	R/W	R/W

The MSTPCR are 8-bit read/write twin registers which work to control the module stop mode. When the MSTP13 bit is set to 1, the Timer J stops its operation at the ending point of the bus cycle to shift to the module stop mode. For more information, see section 4.5, Module Stop Mode. When reset, the MSTPCR is initialized to H'FFFF.

**Bit 5—Module Stop (MSTP13):** This bit works to designate the module stop mode for the Timer J.

#### MSTPCRH

##### Bit 5

MSTP13	Description
0	Cancels the module stop mode of the Timer J
1	Sets the module stop mode of the Timer J (Initial value)

## 14.3 Operation

### 14.3.1 8-Bit Reload Timer (TMJ-1)

The TMJ-1 is an 8-bit reload timer. As the clock source, dividing clock or edge signals through the  $\overline{\text{IRQ1}}$  pin are being used. By selecting the edge signals through the  $\overline{\text{IRQ1}}$  pin, it can also be used as an event counter. While it is working as an event counter, its reloading function is workable simultaneously. When data are written into the reloading register TLJ, these data will be written into the counter TCJ simultaneously. Also, when the counter TCJ underflows, the data of the reloading register TLJ will be reloaded to the counter TCJ.

When the counter underflows, TMJ1I interrupt requests will be issued.

The underflow will be toggled and, by a appropriate selection of the dividing clock, buzzer outputs will be issued or carrier frequencies for remote controlling transmissions can be acquired.

The TMJ-1 and TMJ-2, in combination, can be used as a 16-bit reload timer. Nonetheless, when they are being used, in combination, as a 16-bit timer, word command only is valid and the TCK works as the down counter for the upper 8 bits and the TCJ works as the down counter for the lower 8 bits, means a reloading register of total 16 bits.

When data are written into a 16-bit reloading register, the same data will be written into the 16-bit counter.

Also, when the 16-bit counter underflows, the data of the 16-bit reloading register will be reloaded into the counter.

Even when they are making a 16-bit operation, the TMJ1I interrupt requests of the TMJ-1 and BUZZ outputs are effective. In case these functions are not necessary, make them invalid by programming.

The TMJ-1 and TMJ-2, in combination, can be used for remote controlled data transmission. Regarding the remote controlled data transmission, see section 14.3.3, Remote Controlled Data Transmission.

### 14.3.2 8-Bit Reload Timer (TMJ-2)

The TMJ-2 is an 8-bit down-counting reload timer. As the clock source, dividing clock, edge signals through the  $\overline{\text{IRQ2}}$  pin or the underflow signals from the TMJ-1 are being used. By selecting the edge signals through the  $\overline{\text{IRQ2}}$  pin, it can also be used as an event counter. While it is working as an event counter, its reloading function is workable simultaneously.

When data are written into the reloading register TLK, these data will be written into the counter TCK simultaneously. Also, when the counter TCK underflows, the data of the reloading register TLK will be made to the data counter TCK.

When the counter underflows, TMJ2I interrupt requests will be issued.

The TMJ-2 and TMJ-1, in combination, can be used as a 16-bit reload timer. For more information

on the 16-bit reload timer, see section 14.3.1, 8-bit Reload Timer (TMJ-1).

The TMJ-2 and TMJ-1, in combination, can be operated by remote controlled data transmission. Regarding the remote controlled data transmission, see section 14.3.3, Remote Controlled Data Transmission.

### 14.3.3 Remote Controlled Data Transmission

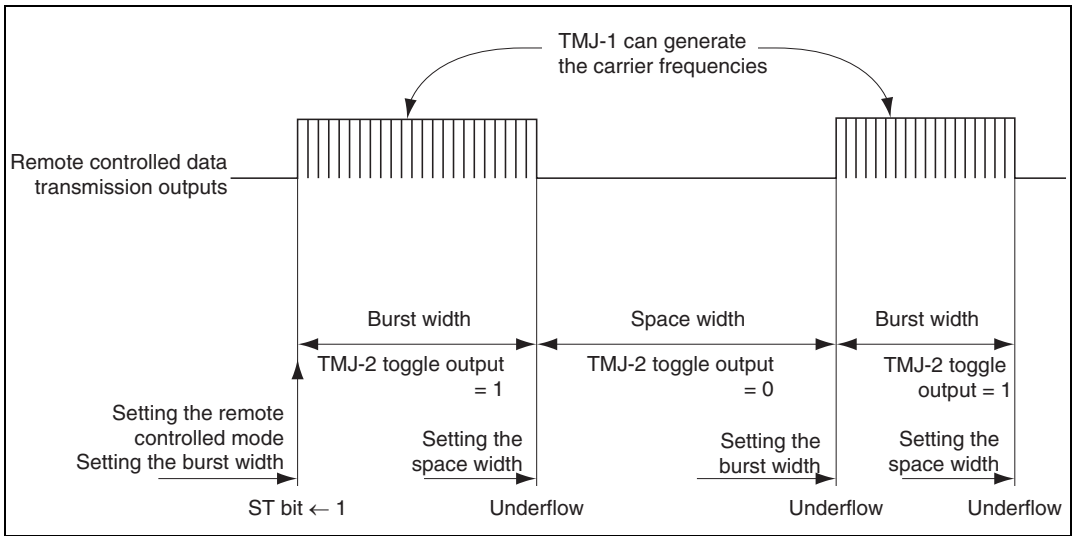
The Timer J is capable of making remote controlled data transmission. The carrier frequencies for the remote controlled data transmission can be generated by the TMJ-1 and the burst width duration and the space width duration can be setup by the TMJ-2.

The data having been written into the reloading register TMJ-1 and into the burst/space duration register (TLK) of the TMJ-2 will be loaded to the counter at the same time as the remote controlled data transmission starts. (Remote controlled data transmission starting bit (ST) ← 1) While remote controlled data transmission is being made, the contents of the burst/space duration register will be loaded to the counter only while reloading is being made by underflow signals. Even when a writing is made to the burst/space duration register while remote controlled data transmission is being made, reloading operation will not be made until an underflow signal is issued. The TMJ-2 issues TMJ2I interrupt requests by the underflow signals. The TMJ-1 performs normal reloading operation (including the TMJ1I interrupt requests).

Figure 14.2 shows the output waveform for the remote controlled data transmission function.

When a shift to the low power consumption mode is effected while remote controlled data transmission is being made, the ST bit will be cleared to 0. When resuming the remote controlled data transmission after returning to the active mode, write 1.





**Figure 14.2 Remote Controlled Data Transmission Output Waveform**

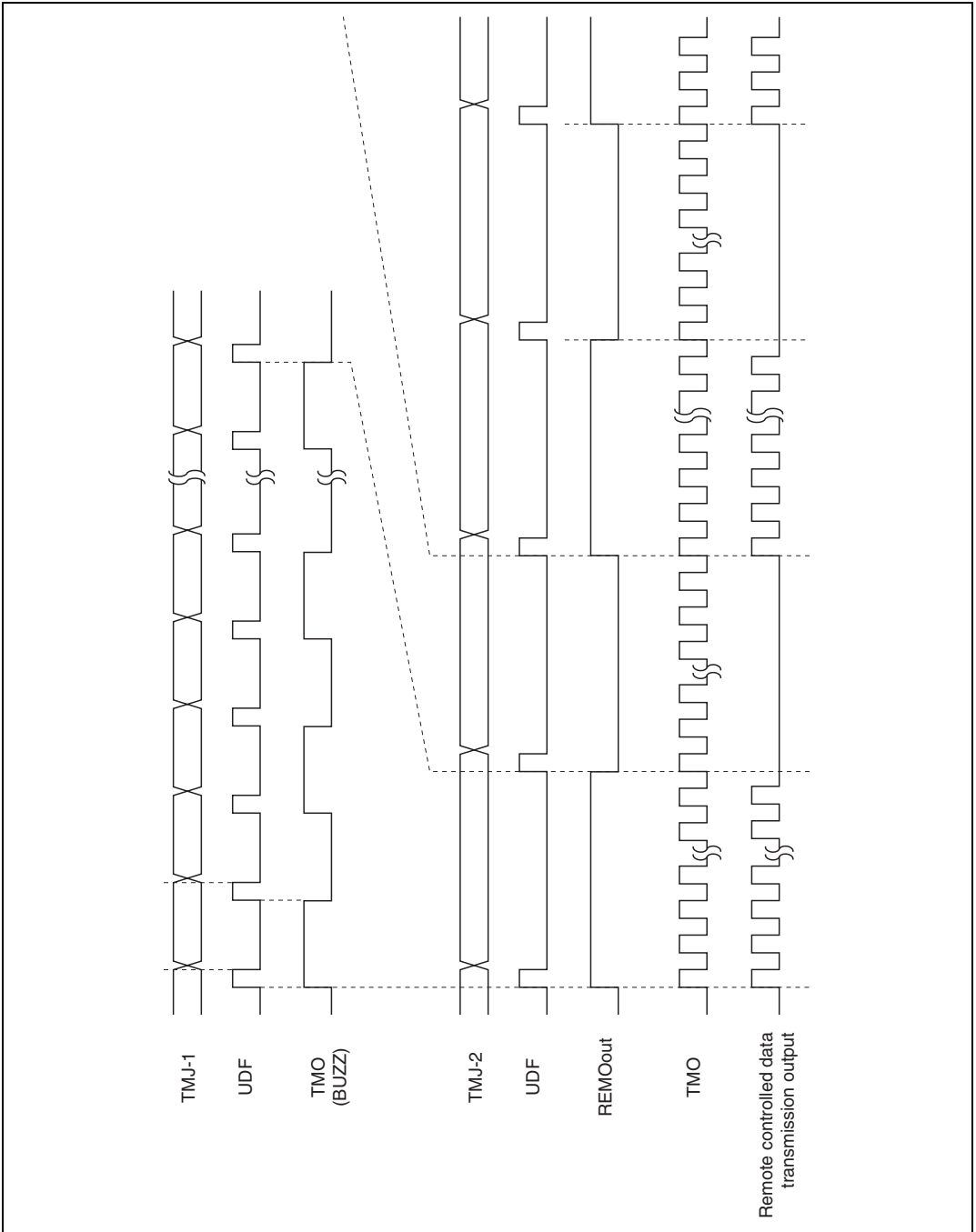


Figure 14.3 Timer Output Timing

When the Timer J is set to the remote controlled operation mode, since the start bit (ST) is being set or cleared in synchronization with the inputting clock to the TMJ-2, a delay upto a cycle of the inputting clock at the maximum occurs, namely, after the ST bit has been set to 1 until the remote controlled data transmission starts. Consequently, when the TLK is updated during the period after setting the ST bit to 1 until the next cycle of the inputting clock comes, the initial burst width will be changed like shown in figure 14.4.

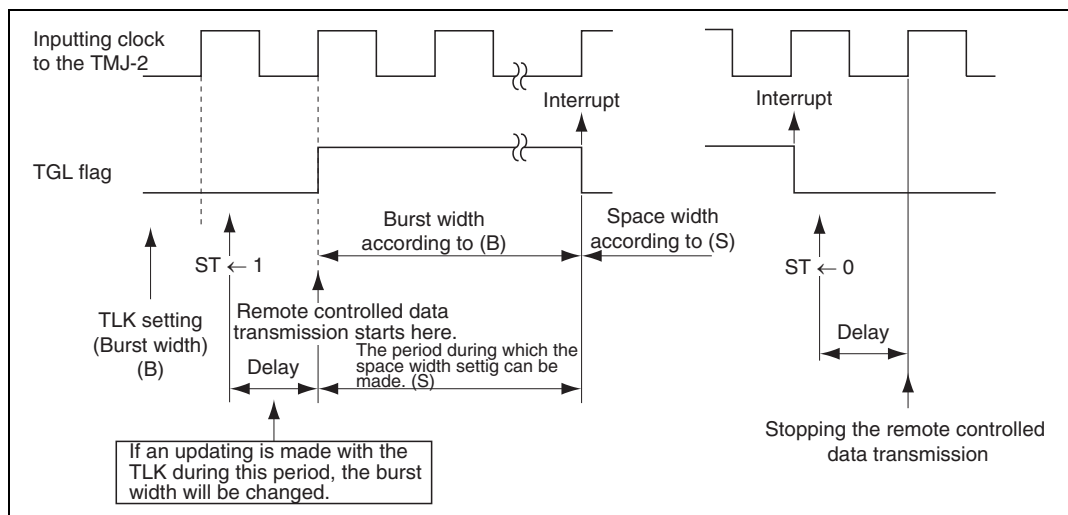
Therefore, when making remote controlled data transmission, determine I/O of the TGL bit at the time of the first burst width control operation without fail. (Or, set the space width to the TLK after waiting for a cycle of the inputting clock.)

After that, operations can be continued by interrupts.

Similarly, pay attention to the control works when ending remote controlled data transmission.

Example)

- 1) Set the burst width with the TLK.
- 2) ST bit  $\leftarrow$  1
- 3) Execute the procedure 4) if the TGL flag = 1.
- 4) Set the space width with the TLK under the status where the TGL flag = 1.
- 5) Make TMJ-2 interrupt.
- 6) Set the burst width with the TLK.
- :
- n) After making TMJ-2 interrupt, make setting of the ST  $\leftarrow$  0 under the status where the TGL flag = 0.



**Figure 14.4 Controls of the Remote Controlled Data Transmission**



---

## Section 15 Timer L

### 15.1 Overview

The Timer L is an 8-bit up/down counter using the control pulses or the CFG division signals as the clock source.

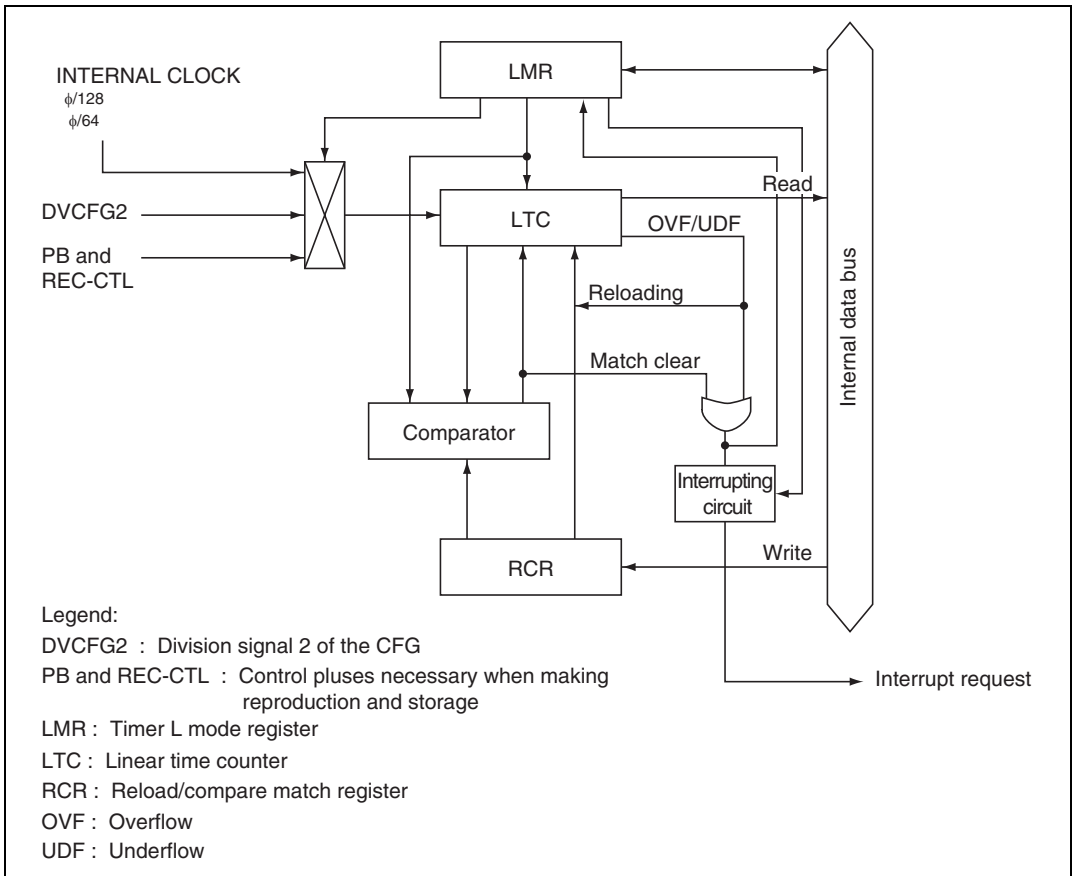
#### 15.1.1 Features

Features of the Timer L are as follows:

- Choices of two different types of internal clocks ( $\phi/128$  and  $\phi/64$ ), DVCFG2 (CFG division signal 2), PB and REC-CTL (control pulses) are available for your selection.
  - In case the PB-CTL is not available, such as when reproducing un-recorded tapes, tape count can be made by the DVCFG2.
  - Selection of the leading edge or the trailing edge is workable with the CTL pulse counting.
- Interrupts occur when the counter overflows or underflows and at occurrences of compare match clear.
- It is possible to switch over between the up-counting and down-counting functions with the counter.

### 15.1.2 Block Diagram

Figure 15.1 shows a block diagram of the Timer L.



**Figure 15.1 Block Diagram of the Timer L**

### 15.1.3 Register Configuration

Table 15.1 shows the register configuration of the Timer L. The linear time counter (LTC) and the reload compare patch register (RCR) are being allocated to the same address.

Reading or writing determines the accessing register.

**Table 15.1 Register Configuration**

<b>Name</b>	<b>Abbrev.</b>	<b>R/W</b>	<b>Size</b>	<b>Initial Value</b>	<b>Address*</b>
Timer L mode register	LMR	R/W	Byte	H'30	H'D112
Linear time counter	LTC	R	Byte	H'00	H'D113
Reload/compare match register	RCR	W	Byte	H'00	H'D113

Note: \* Lower 16 bits of the address.

## 15.2 Descriptions of Respective Registers

### 15.2.1 Timer L Mode Register (LMR)

Bit :	7	6	5	4	3	2	1	0
	LMIF	LMIE	—	—	LMR3	LMR2	LMR1	LMR0
Initial value :	0	0	1	1	0	0	0	0
R/W :	R/(W)*	R/W	—	—	R/W	R/W	R/W	R/W

Note: \* Only 0 can be written to clear the flag.

The timer L mode register (LMR) is an 8-bit read/write register which works to control the interrupts, to select between up-counting and down-counting and to select the clock source. When reset, the LMR is initialized to H'30.

**Bit 7—Timer L Interrupt Requesting Flag (LMIF):** This is the Timer L interrupt requesting flag. It indicates occurrence of overflow or underflow of the LTC or occurrence of compare match clear.

#### Bit 7

LMIF	Description
0	[Clearing condition] When 0 is written after reading 1 (Initial value)
1	[Setting condition] When the LTC overflows, underflows or when compare match clear has occurred

**Bit 6—Enabling Interrupt of the Timer L (LMIE):** This bit works to permit/prohibit occurrence of interrupt of the Timer L when the LTC overflows, underflows or when compare match clear has occurred.

#### Bit 6

LMIE	Description
0	Prohibits occurrence of interrupt of the Timer L (Initial value)
1	Permits occurrence of interrupt of the Timer L

**Bits 5 and 4—Reserved:** When they are read, 1 will always be readout. Writes are disabled.

**Bit 3—Up-Count/Down-Count Control (LMR3):** This bit is for selection if the Timer L is to be controlled to the up-counting function or down-counting function.



- (1) When controlled to the up-counting function
- When any other values than H'00 are input to the RCR, the LTC will be cleared to H'00 before starting counting up. When the LTC value and the RCR value match, the LTC will be cleared to H'00. Also, interrupt requests will be issued by the match signal. (Compare patch clear function)
  - When H'00 is set to the RCR, the counter makes 8-bit interval timer operation to issue a interrupt request when overflowing occurs. (Interval timer function)
- (2) When controlled to the down-counting function
- When a value is set to the RCR, the set value is reloaded to the LTC and counting down starts from that value. When the LTC underflows, the value of the RCR will be reloaded to the LTC. Also, when the LTC underflows, a interrupt request will be issued. (Auto reload timer function)

**Bit 3**

<b>LMR3</b>	<b>Description</b>
0	Controlling to the up-counting function (Initial value)
1	Controlling to the up-counting function

**Bits 2 to 0—Clock Selection (LMR2 to LMR0):** The bits LMR2 to LMR0 work to select the clock to input to the Timer L. Selection of the leading edge or the trailing edge is workable for counting by the PB and the REC-CTL.

<b>Bit 2</b>	<b>Bit 1</b>	<b>Bit 0</b>	<b>Description</b>
<b>LMR2</b>	<b>LMR1</b>	<b>LMR0</b>	
0	0	0	Counts at the rising edge of the PB and REC-CTL (Initial value)
		1	Counts at the falling edge of the PB and REC-CTL
1	0	*	Counts the DVCFG2
	1	*	Counts at $\phi/128$ of the internal clock
1	0	*	Counts at $\phi/128$ of the internal clock
	1	*	Counts at $\phi/64$ of the internal clock

Legend: \* Don't care.

### 15.2.2 Linear Time Counter (LTC)

Bit :	7	6	5	4	3	2	1	0
	LTC7	LTC6	LTC5	LTC4	LTC3	LTC2	LTC1	LTC0
Initial value :	0	0	0	0	0	0	0	0
R/W :	R	R	R	R	R	R	R	R

The linear time counter (LTC) is a readable 8-bit up/down-counter. The inputting clock can be selected by the LMR2 to LMR0 bits of the LMR.

When reset, the LTC is initialized to H'00.

### 15.2.3 Reload/Compare Match Register (RCR)

Bit :	7	6	5	4	3	2	1	0
	RCR7	RCR6	RCR5	RCR4	RCR3	RCR2	RCR1	RCR0
Initial value :	0	0	0	0	0	0	0	0
R/W :	W	W	W	W	W	W	W	W

The reload/compare match register (RCR) is an 8-bit write only register.

When the Timer L is being controlled to the up-counting function, when a compare match value is set to the RCR, the LTC will be cleared at the same time and the LTC will then start counting up from the initial value (H'00).

While, when the Timer L is being controlled to the down-counting function, when a reloading value is set to the RCR, the same value will be loaded to the LTC at the same time and the LTC will then start counting up from said value. Also, when the LTC underflows, the value of the RCR will be reloaded to the LTC.

When reset, the RCR is initialized to H'00.

### 15.2.4 Module Stop Control Register (MSTPCR)

	MSTPCRH								MSTPCRL							
Bit :	7	6	5	4	3	2	1	0	7	6	5	4	3	2	1	0
	MSTP15	MSTP14	MSTP13	MSTP12	MSTP11	MSTP10	MSTP9	MSTP8	MSTP7	MSTP6	MSTP5	MSTP4	MSTP3	MSTP2	MSTP1	MSTP0
Initial value :	1	1	1	1	1	1	1	1	1	1	1	1	1	1	1	1
R/W :	R/W	R/W	R/W	R/W	R/W	R/W	R/W	R/W	R/W	R/W	R/W	R/W	R/W	R/W	R/W	R/W

The MSTPCR are 8-bit read/write twin registers which work to control the module stop mode.

When the MSTP12 bit is set to 1, the Timer L stops its operation at the ending point of the bus cycle to shift to the module stop mode. For more information, see section 4.5, Module Stop Mode.

When reset, the MSTPCR is initialized to H'FFFF.

**Bit 4—Module Stop (MSTP12):** This bit works to designate the module stop mode for the Timer L.

## MSTPCRH

### Bit 4

MSTP12	Description
0	Cancels the module stop mode of the Timer L
1	Sets the module stop mode of the Timer L (Initial value)

## 15.3 Operation

The Timer L is an 8-bit up/down counter.

The inputting clock for the Timer L can be selected by the LMR2 to LMR0 bits of the LMR from the choices of the internal clock ( $\phi/128$  and  $\phi/64$ ), DVCDG2, PB and REC-CTL.

The Timer L is provided with three different types of operation modes, namely, the compare match clear mode when controlled to the up-counting function, the auto reloading mode when controlled to the down-counting function and the interval timer mode.

Respective operation modes and operation methods will be explained below.

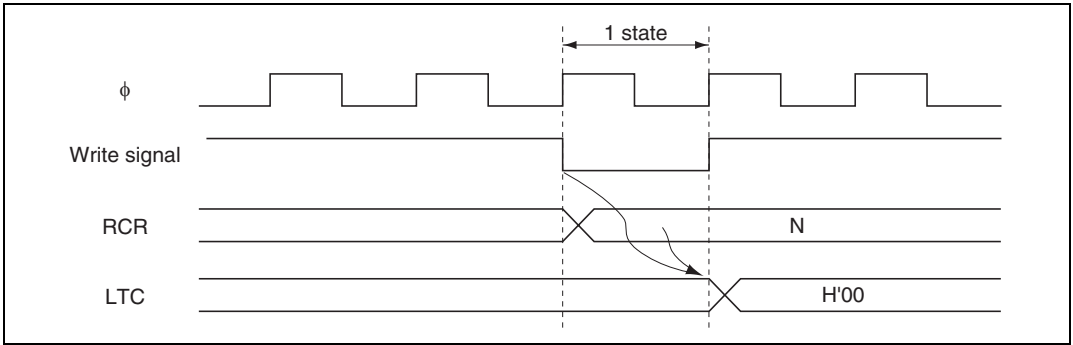
### 15.3.1 Compare Match Clear Operation

When the LMR3 bit of the LMR is cleared to 0, the Timer L will be controlled to the up-counting function.

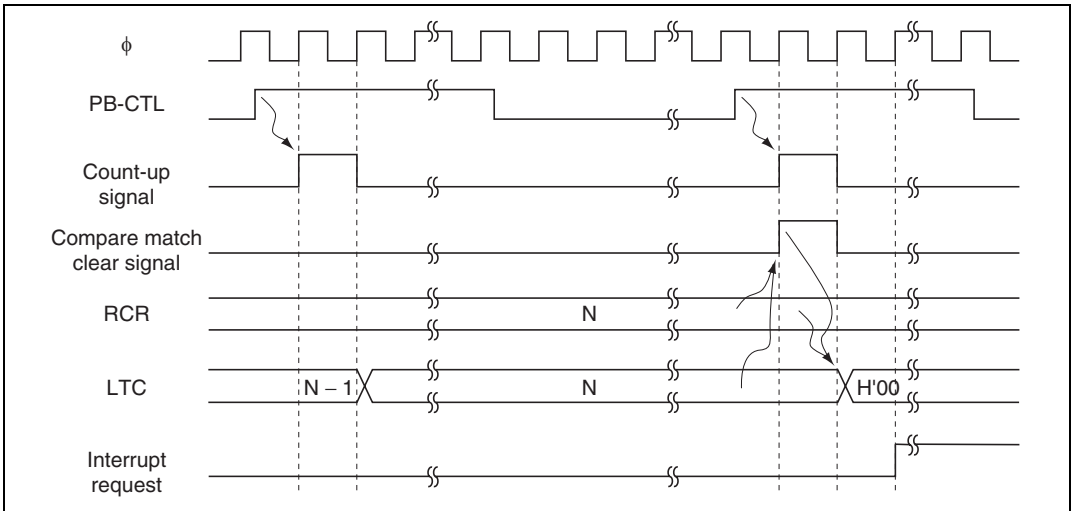
When any other values than H'00 are written into the RCR, the LTC will be cleared to H'00 simultaneously before starting counting up.

Figure 15.2 shows the clear timing of the LTC. When the LTC value and the RCR value match (compare match), the LTC readings will be cleared to H'00 to resume counting from H'00.

Figure 15.3 indicated on the next page shows the compare match clear timing.



**Figure 15.2 RCR Writing and LTC Clearing Timing Chart**



**Figure 15.3 Compare Match Clearing Timing Chart  
(In Case the Rising Edge of the PB-CTL Is Selected)**

---

## Section 16 Timer R

### 16.1 Overview

The Timer R consists of triple 8-bit down-counters. It carries VCR mode identification function and slow tracking function in addition to the reloading function and event counter function.

#### 16.1.1 Features

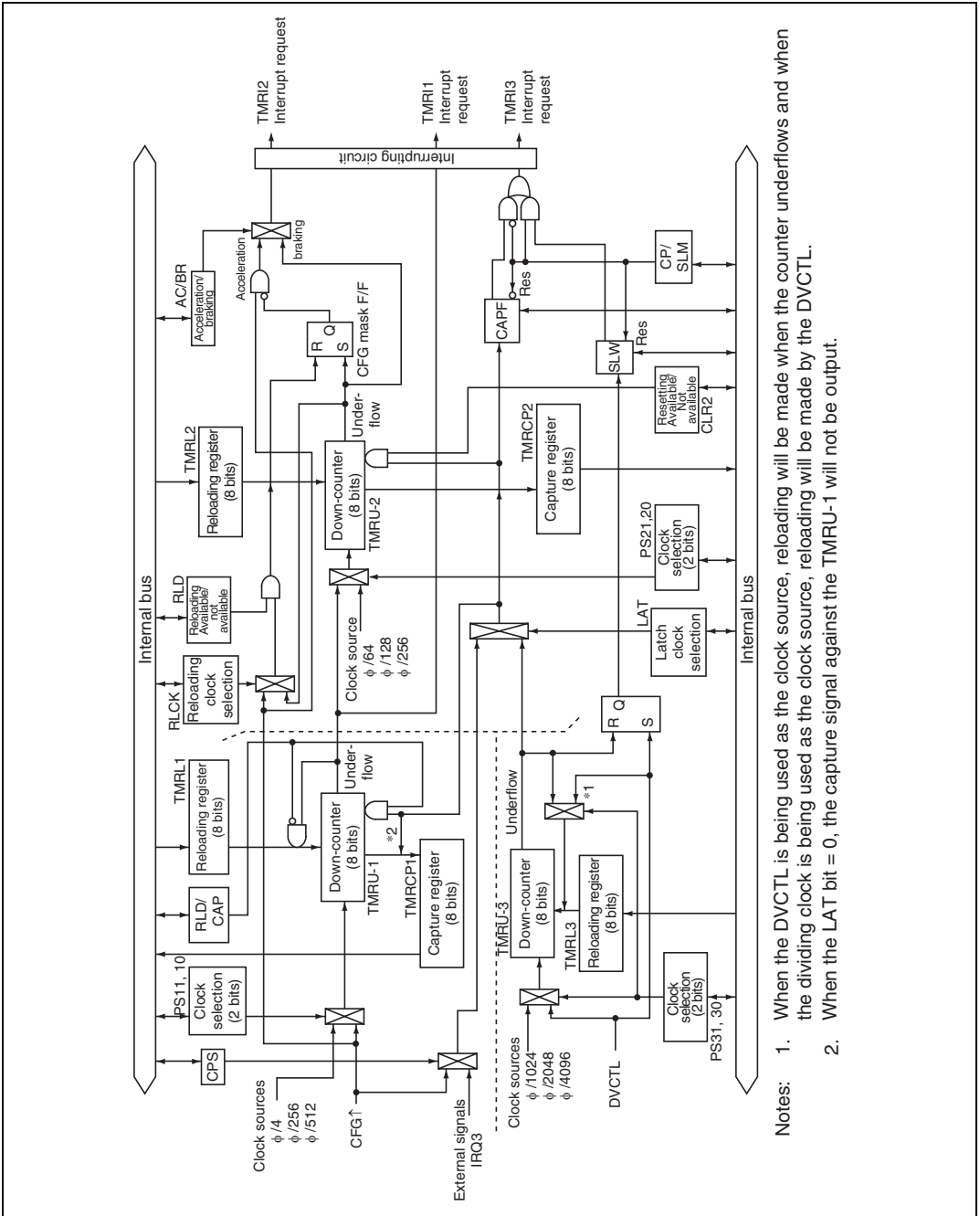
The Timer R consists of triple 8-bit reloading timers. By combining the functions of three units of reloading timers/counters and by combining three units of timers, it can be used for the following applications:

- Applications making use of the functions of three units of reloading timers.
- For identification of the VCR mode.
- For reel controls.
- For acceleration and braking of the capstan motor when being applied to intermittent movements.
- Slow tracking mono-multi applications.

#### 16.1.2 Block Diagram

The Timer R consists of three units of reload timer counters, namely, two units of reload timer counters equipped with capturing function (TMRU-1 and TMRU-2) and a unit of reload timer counter (TMRU-3).

Figure 16.1 is a block diagram of the Timer R.



- Notes:
1. When the DVCTL is being used as the clock source, reloading will be made when the counter underflows and when the dividing clock is being used as the clock source, reloading will be made by the DVCTL.
  2. When the LAT bit = 0, the capture signal against the TMRU-1 will not be output.

Figure 16.1 Block Diagram of the Timer R

### 16.1.3 Pin Configuration

Table 16.1 shows the pin configuration of the Timer R.

**Table 16.1 Pin Configuration**

Name	Abbrev.	I/O	Function
Input capture inputting pin	IRQ3	Input	Input capture inputting for the Timer R

### 16.1.4 Register Configuration

Table 16.2 shows the register configuration of the Timer R.

**Table 16.2 Register Configuration**

Name	Abbrev.	R/W	Size	Initial Value	Address
Timer R mode register 1	TMRM1	R/W	Byte	H'00	H'D118
Timer R mode register 2	TMRM2	R/W	Byte	H'00	H'D119
Timer R control/status register	TMRCS	R/W	Byte	H'03	H'D11F
Timer R capture register 1	TMRCP1	R	Byte	H'FF	H'D11A
Timer R capture register 2	TMRCP2	R	Byte	H'FF	H'D11B
Timer R load register 1	TMRL1	W	Byte	H'FF	H'D11C
Timer R load register 2	TMRL2	W	Byte	H'FF	H'D11D
Timer R load register 3	TMRL3	W	Byte	H'FF	H'D11E

Note: Memories of respective registers will be preserved even under the low power consumption mode. Nonetheless, the CAPF flag and SLW flag of the TMRM2 will be cleared to 0.

## 16.2 Descriptions of Respective Registers

### 16.2.1 Timer R Mode Register 1 (TMRM1)

Bit :	7	6	5	4	3	2	1	0
	CLR2	AC/BR	RLD	RLCK	PS21	PS20	RLD/CAP	CPS
Initial value :	0	0	0	0	0	0	0	0
R/W :	R/W	R/W	R/W	R/W	R/W	R/W	R/W	R/W

The timer R mode register 1 (TMRM1) works to control the acceleration and braking processes and to select the inputting clock for the TMRU-2. This is an 8-bit read/write register.

When reset, the TMRM1 is initialized to H'00.

**Bit 7—Selecting Clearing/Not Clearing of TMRU-2 (CLR2):** This bit is used for selecting if the TMRU-2 counter reading is to be cleared or not as it is captured.

#### Bit 7

CLR2	Description
0	TMRU-2 counter reading is not to be cleared as soon as it is captured. (Initial value)
1	TMRU-2 counter reading is to be cleared as soon as it is captured

**Bit 6—Selecting the Acceleration/Braking Processing (AC/BR):** This bit works to control occurrences of interrupt requests to detect completion of acceleration or braking while the capstan motor is making intermittent revolutions.

For more information, see section 16.3.6, Acceleration and Braking Processes of the Capstan Motor.

#### Bit 6

AC/BR	Description
0	Acceleration (Initial value)
1	Braking



**Bit 5—Selection if Using the TMRU-2 for Reloading or Not Doing So (RLD):** This bit is used for selecting if the TMRU-2 reload function is to be turned on or not.

**Bit 5**

RLD	Description
0	Not using the TMRU-2 as the reload timer (Initial value)
1	Using the TMRU-2 as the reload timer

**Bit 4—Selection of the Reloading Timing for the TMRU-2 (RLCK):** This bit works to select if the TMRU-2 is reloading by the CFG or by underflowing of the TMRU-2 counter. This choice is valid only when the bit 5 (RLD) is being set to 1.

**Bit 4**

RLCK	Description
0	Reloading at the rising edge of the CFG (Initial value)
1	Reloading by underflowing of the TMRU-2

**Bits 3 and 2: Selecting the Clock Source for the TMRU-2 (PS21 and PS20):** These bits work to select the inputting clock to the TMRU-2.

Bit 3 PS21	Bit 2 PS20	Description
0	0	Counting by underflowing of the TMRU-1 (Initial value)
	1	Counting by the PSS, $\phi/256$
1	0	Counting by the PSS, $\phi/128$
	1	Counting by the PSS, $\phi/64$

**Bit 1—Selection of the Operation Mode of the TMRU-1 (RLD/CAP):** This bit works to select if the operation mode of the TMRU-1 is reload timer mode or capture timer mode. Under the capture timer mode, reloading operation will not be made. Also, the counter reading will be cleared as soon as capture has been made.

**Bit 1**

RLD/CAP	Description
0	The TMRU-1 works as the reloading timer (Initial value)
1	The TMRU-1 works as the capture timer

**Bit 0—Selection of the Capture Signals of the TMRU-1 (CPS):** In combination with the LAT bit (Bit 7) of the TMR2, this bit works to select the capture signals of the TMRU-1. This bit becomes valid when the LAT bit is being set to 1. It will also become valid when the RLD/CAP bit (Bit 1) is being set to 1. Nonetheless, it will be invalid when the RLD/CAP bit (Bit 1) is being set to 0.

**Bit 0**

CPS	Description
0	Capture signals at the rising edge of the CFG (Initial value)
1	Capture signals at the edge of the IRQ3

**16.2.2 Timer R Mode Register 2 (TMRM2)**

Bit :	7	6	5	4	3	2	1	0
	LAT	PS11	PS10	PS31	PS30	CP/SLM	CAPF	SLW
Initial value :	0	0	0	0	0	0	0	0
R/W :	R/W	R/W	R/W	R/W	R/W	R/W	R/(W)*	R/(W)*

Note: \* The CAPF bit and the SLW bit, respectively, works to latch the interrupt causes and writing 0 only is valid. Consequently, when these bits are being set to 1, respective interrupt requests will not be issued. Therefore, it is necessary to check these bits during the course of the interrupt processing routine to have them cleared.  
Also, priority is given to the set and, when an interrupt cause occur while the a clearing command (BCLR, MOV, etc.) is being executed, the CAPF bit and the SLW bit will not be cleared respectively and it thus becomes necessary to pay attention to the clearing timing.

The timer R mode register 2 (TMRM2) is an 8-bit read/write register which works to identify the operation mode and to control the slow tracking processing.

When reset, the TMRM2 is initialized to H'00.

**Bit 7—Selection of the Capture Signals of the TMRU-2 (LAT):** In combination with the CPS bit (Bit 0) of the TMRM1, this bit works to select the capture signals of the TMRU-2.

<b>TMRM2</b>		<b>TMRM1</b>	
<b>Bit 7</b>		<b>Bit 0</b>	
<b>LAT</b>	<b>CPS</b>		<b>Description</b>
0	*		Captures when the TMRU-3 underflows (Initial value)
1	0		Captures at the rising edge of the CFG
	1		Captures at the edge of the IRQ3

Legend: \* Don't care.

**Bits 6 and 5—Selecting the Clock Source for the TMRU-1 (PS11 and PS10):** These bits work to select the inputting clock to the TMRU-1.

<b>Bit 6</b>		<b>Bit 5</b>	
<b>PS11</b>	<b>PS10</b>		<b>Description</b>
0	0		Counting at the rising edge of the CFG (Initial value)
	1		Counting by the PSS, $\phi/4$
1	0		Counting by the PSS, $\phi/256$
	1		Counting by the PSS, $\phi/512$

**Bits 4 and 3—Selecting the Clock Source for the TMRU-3 (PS31 and PS30):** These bits work to select the inputting clock to the TMRU-3.

<b>Bit 4</b>		<b>Bit 3</b>	
<b>PS31</b>	<b>PS30</b>		<b>Description</b>
0	0		Counting at the rising edge of the DVCTL from the dividing circuit. (Initial value)
	1		Counting by the PSS, $\phi/4096$
1	0		Counting by the PSS, $\phi/2048$
	1		Counting by the PSS, $\phi/1024$

**Bit 2—Selection of Interrupt Causes (CP/SLM):** This bit works to select the interrupt causes for the TMRI3.

**Bit 2**

CP/SLM	Description
0	Makes interrupt requests upon the capture signals of the TMRU-2 valid (Initial value)
1	Makes interrupt requests upon ending of the slow tracking mono-multi valid

**Bit 1—Capture Signal Flag (CAPF):** This is a flag being set out by the capture signal of the TMRU-2. Although both reading/writing are possible, 0 only is valid for writing. Also, priority is being given to the set and, when the "capture signal" and "writing 0" occur simultaneously, this flag bit remains being set to 1 and the interrupt request will not be issued and it is necessary to be attentive about this fact.

When the CP/SLM bit (Bit 2) is being set to 1, this CAPF bit should always be set to 0.

The CAPF flag is cleared to 0 under the low power consumption mode.

**Bit 1**

CAPF	Description
0	[Clearing condition] (Initial value) When 0 is written after reading 1
1	[Setting condition] At occurrences of the TMRU-2 capture signals while the CP/SLM bit is being set to 0

**Bit 0—Slow Tracking Mono-Multi Flag (SLW):** This is a flag being set out when the slow tracking mono-multi processing ends. Although both reading/writing are possible, 0 only is valid for writing.

Also, priority is being given to the set and, when "ending of the slow tracking mono-multi processing" and "writing 0" occur simultaneously, this flag bit remains being set to 1 and the interrupt request will not be issued and it is necessary to be attentive about this fact.

When the CP/SLM bit (Bit 2) is being set to 0, this SLW bit should always be set to 0.

The SLW flag is cleared to 0 under the low power consumption mode.

**Bit 0**

SLW	Description
0	[Clearing condition] (Initial value) When 0 is written after reading 1
1	[Setting condition] When the slow tracking mono-multi processing ends while the CP/SLM bit is being set to 1

### 16.2.3 Timer R Control/Status Register (TMRCS)

Bit :	7	6	5	4	3	2	1	0
	TMRI3E	TMRI2E	TMRI1E	TMRI3	TMRI2	TMRI1	—	—
Initial value :	0	0	0	0	0	0	1	1
R/W :	R/W	R/W	R/W	R/(W)*	R/(W)*	R/(W)*	—	—

Note: \* Only 0 can be written to clear the flag.

The timer R control/status register (TMRCS) works to control the interrupts of the Timer R. The TMRCS is an 8-bit read/write register. When reset, the TMRCS is initialized to H'03.

**Bit 7—Enabling the TMRI3 Interrupt (TMRI3E):** This bit works to permit/prohibit occurrence of the TMRI3 interrupt when an interrupt cause being selected by the CP/SLM bit of the TMRM2 has occurred, such as occurrences of the TMRU-2 capture signals or when the slow tracking mono-multi processing ends, and the TMRI3 has been set to 1.

#### Bit 7

TMRI3E	Description
0	Prohibits occurrences of TMRI3 interrupts (Initial value)
1	Permits occurrences of TMRI3 interrupts

**Bit 6—Enabling the TMRI2 Interrupt (TMRI2E):** This bit works to permit/prohibit occurrence of the TMRI2 interrupt when the TMRI2 has been set to 1 by issuance of the underflow signal of the TMRU-2 or by ending of the slow tracking mono-multi processing.

#### Bit 6

TMRI2E	Description
0	Prohibits occurrences of TMRI2 interrupts (Initial value)
1	Permits occurrences of TMRI2 interrupts

**Bit 5—Enabling the TMRI1 Interrupt (TMRI1E):** This bit works to permit/prohibit occurrence of the TMRI1 interrupt when the TMRI1 has been set to 1 by issuance of the underflow signal of the TMRU-1.

**Bit 5**

TMRI1E	Description	
0	Prohibits occurrences of TMRI1 interrupts	(Initial value)
1	Permits occurrences of TMRI1 interrupts	

**Bit 4—TMRI3 Interrupt Requesting Flag (TMRI3):** This is the TMRI3 interrupt requesting flag.

It indicates occurrence of an interrupt cause being selected by the CP/SLM bit of the TMRM2, such as occurrences of the TMRU-2 capture signals or ending of the slow tracking mono-multi processing.

**Bit 4**

TMRI3	Description	
0	[Clearing condition] When 0 is written after reading 1	(Initial value)
1	[Setting condition] At occurrence of the interrupt cause being selected by the CP/SLM bit of the TMRM2	

**Bit 3—TMRI2 Interrupt Requesting Flag (TMRI2):** This is the TMRI2 interrupt requesting flag.

It indicates occurrences of the TMRU-2 underflow signals or ending of the acceleration/braking processing of the capstan motor.

**Bit 3**

TMRI2	Description	
0	[Clearing condition] When 0 is written after reading 1	(Initial value)
1	[Setting condition] At occurrences of the TMRU-2 underflow signals or ending of the acceleration/ braking processing of the capstan motor	

**Bit 2—TMRI1 Interrupt Requesting Flag (TMRI1):** This is the TMRI1 interrupt requesting flag.

It indicates occurrences of the TMRU-1 underflow signals.

## Bit 2

TMRI1	Description
0	[Clearing condition] When 0 is written after reading 1. (Initial value)
1	[Setting condition] When the TMRU-1 underflows.

**Bits 1 and 0—Reserved:** When they are read, 1 will always be readout. Writes are disabled.

### 16.2.4 Timer R Capture Register 1 (TMRCP1)

Bit :	7	6	5	4	3	2	1	0
	TMRC17	TMRC16	TMRC15	TMRC14	TMRC13	TMRC12	TMRC11	TMRC10
Initial value :	1	1	1	1	1	1	1	1
R/W :	R	R	R	R	R	R	R	R

The timer R capture register 1 (TMRCP1) works to store the capture data of the TMRU-1. During the course of the capturing operation, the TMRU-1 counter readings are captured by the TMRCP1 at the CFG edge or the IRQ3 edge. The capturing operation of the TMRU-1 is being performed using 16 bits, in combination with the capturing operation of the TMRU-2.

The TMRCP1 is an 8-bit read only register. When reset, the TMRC10 is initialized to H'FF.

- Notes:
1. When the TMRCP1 is readout while the capture signal is being received, the reading data become unstable. Pay attention to the timing for reading out.
  2. When a shift to the low power consumption mode is made while the capturing operation is in progress, the counter reading becomes unstable. After returning to the active mode, always write "H'FF" into the TMRL1 to initialize the counter.

### 16.2.5 Timer R Capture Register 2 (TMRCP2)

Bit :	7	6	5	4	3	2	1	0
	TMRC27	TMRC26	TMRC25	TMRC24	TMRC23	TMRC22	TMRC21	TMRC20
Initial value :	1	1	1	1	1	1	1	1
R/W :	R	R	R	R	R	R	R	R

The timer R capture register 2 (TMRCP2) works to store the capture data of the TMRU-2. At each CFG edge, IRQ3 edge, or at occurrence of underflow of the TMRU-3, the TMRU-2 counter readings are captured by the TMRCP2.

The TMRCP2 is an 8-bit read only register. When reset, the TMRCS will be initialized into H'FF.

- Notes:
1. When the TMRCP2 is readout while the capture signal is being received, the reading data become unstable. Pay attention to the timing for reading out.
  2. When a shift to the low power consumption mode is made, the counter reading becomes unstable. After returning to the active mode, always write "H'FF" into the TMRL2 to initialize the counter.

### 16.2.6 Timer R Load Register 1 (TMRL1)

Bit :	7	6	5	4	3	2	1	0
	TMR17	TMR16	TMR15	TMR14	TMR13	TMR12	TMR11	TMR10
Initial value :	1	1	1	1	1	1	1	1
R/W :	W	W	W	W	W	W	W	W

The timer R load register 1 (TMRL1) is an 8-bit write only register which works to set the load value of the TMRU-1.

When a load value is set to the TMRL1, the same value will be set to the TMRU-1 counter simultaneously and the counter starts counting down from the set value. Also, when the counter underflows during the course of the reload timer operation, the TMRL1 value will be set to the counter.

When reset, the TMRL1 is initialized to H'FF.



### 16.2.7 Timer R Load Register 2 (TMRL2)

Bit :	7	6	5	4	3	2	1	0
	TMR27	TMR26	TMR25	TMR24	TMR23	TMR22	TMR21	TMR20
Initial value :	1	1	1	1	1	1	1	1
R/W :	W	W	W	W	W	W	W	W

The timer R load register 2 (TMRL2) is an 8-bit write only register which works to set the load value of the TMRU-2.

When a load value is set to the TMRL2, the same value will be set to the TMRU-2 counter simultaneously and the counter starts counting down from the set value. Also, when the counter underflows or a CFG edge is detected during the course of the reload timer operation, the TMRL2 value will be set to the counter.

When reset, the TMRL2 is initialized to H'FF.

### 16.2.8 Timer R Load Register 3 (TMRL3)

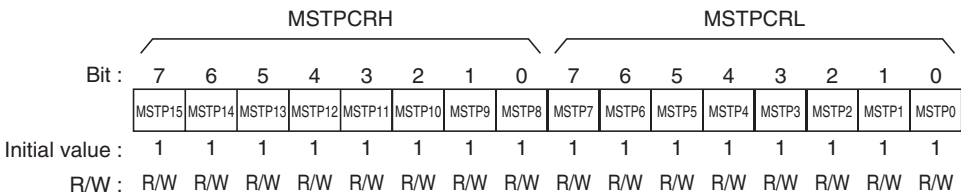
Bit :	7	6	5	4	3	2	1	0
	TMR37	TMR36	TMR35	TMR34	TMR33	TMR32	TMR31	TMR30
Initial value :	1	1	1	1	1	1	1	1
R/W :	W	W	W	W	W	W	W	W

The timer R load register 3 (TMRL3) is an 8-bit write only register which works to set the load value of the TMRU-3.

When a load value is set to the TMRL3, the same value will be set to the TMRU-3 counter simultaneously and the counter starts counting down from the set value. Also, when the counter underflows or a DVCTL edge is detected, the TMRL2 value will be set to the counter. (Reloading will be made by the underflowing signals when the DVCTL signal is selected as the clock source, and reloading will be made by the DVCTL signals when the dividing clock is selected as the clock source.)

When reset, the TMRL3 is initialized to H'FF.

## 16.2.9 Module Stop Control Register (MSTPCR)



The MSTPCR are 8-bit read/write twin registers which work to control the module stop mode. When the MSTP11 bit is set to 1, the Timer R stops its operation at the ending point of the bus cycle to shift to the module stop mode. For more information, see section 4.5, Module Stop Mode. When reset, the MSTPCR is initialized to H'FFFF.

**Bit 3—Module Stop (MSTP11):** This bit works to designate the module stop mode for the Timer R.

### MSTPCRH

#### Bit 3

MSTP11	Description
0	Cancels the module stop mode of the Timer R
1	Sets the module stop mode of the Timer R <span style="float: right;">(Initial value)</span>

## 16.3 Operation

### 16.3.1 Reload Timer Counter Equipped with Capturing Function TMRU-1

The reload timer counter equipped with capturing function, TMRU-1, consists of an 8-bit down-counter, a reloading register and a capture register.

The clock source can be selected from among the leading edge of the CFG signals and three types of dividing clocks. It is also selectable whether using it as a reload counter or as a capture counter. Even when the capturing function is selected, the counter readings can be updated by writing the values into the reloading register.

When the counter underflows, the TMRI1 interrupt request will be issued.

The initial values of the TMRU-1 counter, reloading register and capturing register are all H'FF.

#### (1) Operation of the Reload Timer

When a value is written into to the reloading register, the same value will be written into the counter simultaneously. Also, when the counter underflows, the reloading register value will be reloaded to the counter. The TMRU-1 is a dividing circuit for the CFG. In combination with the TMRU-2 and TMRU-3, it can also be used for the mode identification purpose.

#### (2) Capturing Operation

Capturing operation is carried out in combination with the TMRU-2 using the combined 16 bits. It can be so programmed that the counter may be cleared by the capture signal. The CFG edges or IRQ3 edges are used as the capture signals. It is possible to issue the TMRI3 interrupt request by the capture signal.

In addition to the capturing function being worked out in combination with the TMRU-2, the TMRU-1 can be used as a 16-bit CFG counter. Selecting the IRQ3 as the capture signal, the CFG within the duration of the reel pulse being input into the  $\overline{\text{IRQ3}}$  pin can be counted by the TMRU-1.

### 16.3.2 Reload Timer Counter Equipped with Capturing Function TMRU-2

The reload timer counter equipped with capturing function, TMRU-2, consists of an 8-bit down-counter, a reloading register and a capture register.

The clock source can be selected from among the undedrflowing signal of the TMRU-1 and three types of dividing clocks. Also, although the reloading function is workable during its capturing operation, equipping or not of the reloading function is selectable. Even when without-reloading-function is chosen, the counter reading can be updated by writing the values to the reloading register.

When the counter underflows, the TMRI2 interrupt request will be issued.

The initial values of the TMRU-2 counter, reloading register and capturing register are all H'FF.

#### (1) Operation of the Reload Timer

When a value is written into to the reloading register, the same value will be written into the counter, simultaneously. Also, when the counter underflows, the reloading register value will be reloaded to the counter.

The TMRU-2 can make acceleration and braking work for the capstan motor using the reload timer operation.

#### (2) Capturing Operation

Using the capture signals, the counter reading can be latched into the capturing register. As the capture signal, you can choose from among edges of the CFG, edges of the IRQ3 or the underflow signals of the TMRU-3. It is possible to issue the TMRI3 interrupt request by the capture signal.

The capturing function (stopping the reloading function) of the TMRU-2, in combination with the TMRU-1 and TMRU-3, can also be used for the mode identification purpose.

### 16.3.3 Reload Counter Timer TMRU-3

The reload counter timer TMRU-3 consists of an 8-bit down-counter and a reloading register. Its clock source can be selected from between the undedrflowing signal of the counter and the edges of the DVCTL signals. (When the DVCTL signal is selected as the clock source, reloading will be effected by the underflowing signals and when the dividing clock is selected as the clock source, reloading will be effected by the DVCTL signals.) The reloading signal works to reload the reloading register value into the counter. Also, when a value is written into to the reloading register, the same value will be written into the counter, simultaneously.

The initial values of the counter and the reloading register are H'FF.

The underflowing signals can be used as the capturing signal for the TMRU-2.

The TMRU-3 can also be used as a dividing circuit for the DVCTL. Also, in combination with the TMRU-1 and TMRU-2 (capturing function), the TMRU-3 can be used for the mode identification

purpose. Since the divided signals of the DVCTL are being used as the clock source, CTL signals (DVCTL) conforming to the double speed can be input when making searches. These DVCTL signals can also be used for phase controls of the capstan motor.

Also, by selecting the dividing clock as the clock source, it is possible to make a delay with the edges of the DVCTL to provide the slow tracking mono-multi function.

### 16.3.4 Mode Identification

When making mode identification (2/4/6 identification) of the SP/LP/EP modes of reproducing tapes, the TMRU-1 (CFG dividing circuit), TMRU-2 (capturing function/without reloading function) and TMRU-3 (DVCTL dividing circuit) of the Timer R should be used.

The Timer R will become to the aforementioned status after a reset.

Under the aforementioned status, the divided CFG should be written into the reloading register of the TMRU-1 and divided DVCTL should be written into the reloading register of the TMRU-3.

When the TMRU-3 underflows, the counter value of the TMRU-2 is captured. Such capturing register value represents the number of the CFG within the DVCTL cycle.

As aforementioned, the Timer R can work to count the number of the CFG corresponding to "n" times of DVCTL's or to identify the mode being searched.

For exemplary settings for the register, see section 16.5.1, Mode Identification.

### 16.3.5 Reeling Controls

CFG counts can be captured by making 16-bit capturing operation combining the TMRU-1 and TMRU-2. By choosing the IRQ3 as the capture signal, and by counting the CFG within the duration of the reel pulse being input through the  $\overline{\text{IRQ3}}$  pin, reeling controls, etc. can be effected.

For exemplary settings for the register, see section 16.5.2, Reeling Controls.

### 16.3.6 Acceleration and Braking Processes of the Capstan Motor

When making intermittent movements such as those for slow reproductions or for still reproductions, it is necessary to conduct quick accelerations and abrupt stoppings of the capstan motor. The acceleration and braking processes will function to check if the revolution of a capstan motor has reached the prescribed rate when accelerated or braked. For this purpose, the TMRU-2 (reloading function) should be used.

When making accelerations:

- (1) Set the AC/BR bit of the TMRM1 to acceleration. (Set to 1). Also, use the rising edge of the CFG as the reloading signal.

- (2) Set the prescribed time on the CFG frequency to deem as the acceleration has been finished, into the reloading register.
- (3) The TMRU-2 will work to down-count the reloading data.
- (4) In case the acceleration has not been finished (in case the CFG signal is not input even when the prescribed time has elapsed = underflowing of down-counting has occurred), such underflowing works to set to CFG mask F/F (masking movement) and the reload timer will be cleared by the CFG.
- (5) When the acceleration has been finished (when the CFG signal is input before the prescribed time has elapsed = reloading movement has been made before the down counter underflows), an interrupt request will be issued because of the CFG.

When making braking:

- (1) Set the AC/BR bit of the TMRM1 to braking. (Clear to 0). Also, use the rising edge of the CFG as the reloading signal.
- (2) Set the prescribed time on the CFG frequency to deem as the braking has been finished, into the reloading register.
- (3) The TMRU-2 will work to down-count the reloading data.
- (4) In case the braking has not been finished (when the CFG signal is input before the prescribed time has elapsed = reloading movement has been made before the down counter underflows), the reload timer movement will continue.
- (5) When the acceleration has been finished (when the CFG signal is not input even when the prescribed time has elapsed = underflowing of down-counting has occurred), interrupt request will be issued because of the underflowing signal.

The acceleration and braking processes should be employed when making special reproductions, in combination with the slow tracking mono-multi function being outlined below.

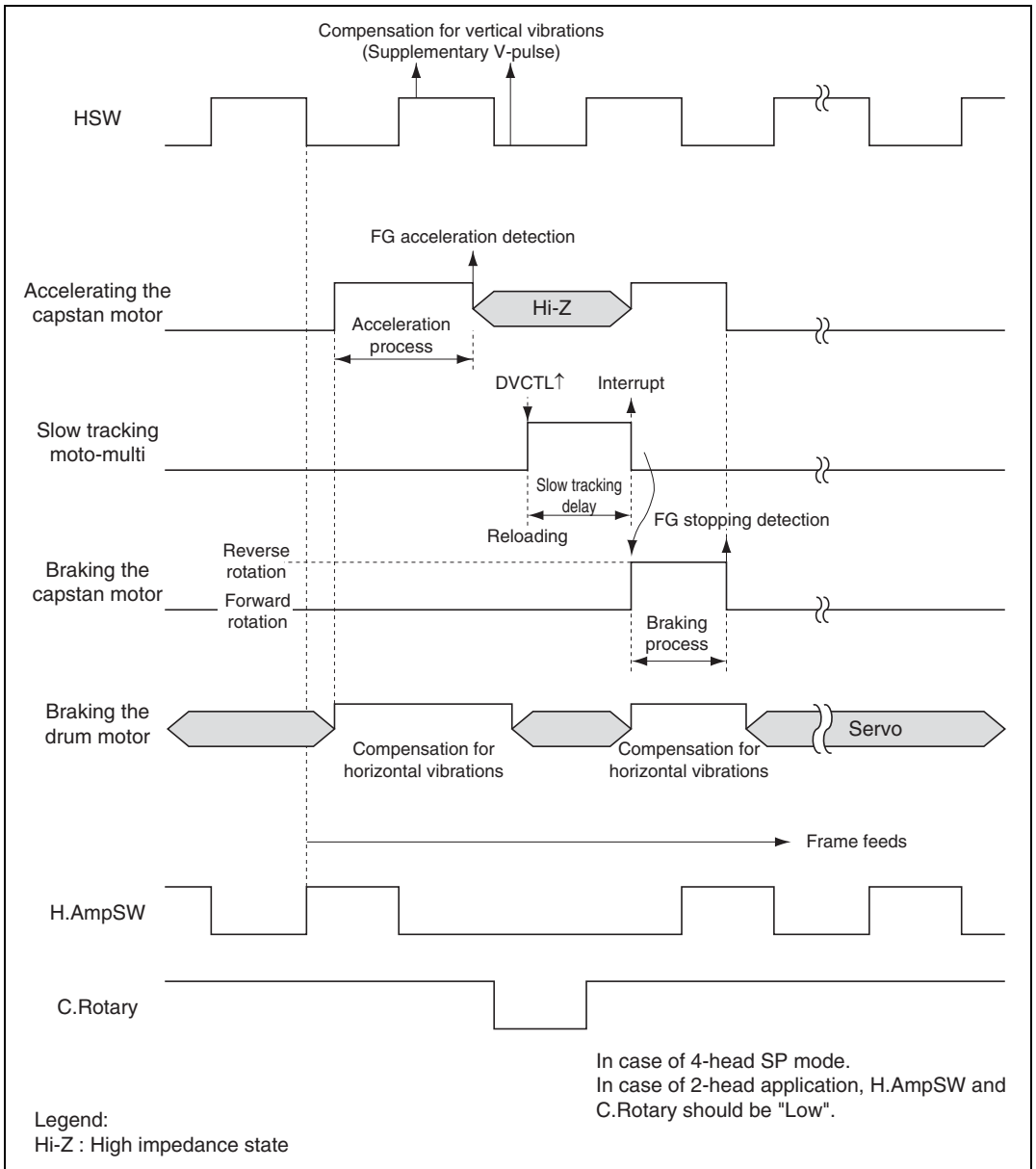
For exemplary settings for the register, see section 16.5.4, Acceleration and Braking Processes of the Capstan Motor.

### 16.3.7 Slow Tracking Mono-Multi Function

When performing slow reproductions or still reproductions, the braking timing for the capstan motor is determined by use of the edge of the DVCTL signal. The slow tracking mono-multi function works to measure the time from the rising edge of the DVCTL signal down to the desired point to issue the interrupt request. In actual programming, this interrupt should be used to activate the brake of the capstan motor. The TMRU-3 should be used to perform time measurements for the slow tracking mono-multi function. Also, the braking process can be made using the TMRU-2. Figure 16.2 below shows the exemplary time series movements when a slow reproduction is being

performed.

For exemplary settings for the register, see section 16.5.3, Slow Tracking Mono-Multi Function.



**Figure 16.2 Exemplary Time Series Movements when a Slow Reproduction Is Being Performed**

## 16.4 Interrupt Cause

The interrupt causes for the Timer R are 3-causes of the TMRI3 bit through TMRI1 bit of the timer R control/status register (TMRCS).

- (a) Interrupts being caused by the underflowing of the TMRU-1 (TMRI1)

These interrupts will constitute the timing for reloading with the TMRU-1.

- (b) Interrupts being caused by the underflowing of the TMRU-2 or by an end of the acceleration or braking process (TMRI2)

When interrupts occur at the reload timing of the TMRU-2, clear the AC/BR (acceleration/braking) bit of the timer R mode register 1 (TMRM1) to 0.

- (c) Interrupts being caused by the capture signals of the TMRU-3 and by ending the slow tracking mono-multi process (TMRI3)

Since these two interrupt causes are constituting the OR, it becomes necessary to determine which interrupt cause is occurring using the software.

Respective interrupt causes are being set to the CAPF flag or the SLW flag of the timer R mode register 2 (TMRM2), have the software determine which.

Since the CAPF flag and the SLW flag will not be cleared automatically, program the software to clear them. (Writing 0 only is valid for these flags.) Unless these flags are cleared, detection of the next cause becomes unworkable. Also, if the CP/SLM bit is changed leaving these flags un-cleared as they are, these flags will get cleared.



## 16.5 Exemplary Settings for Respective Functions

### 16.5.1 Mode Identification

When making mode identification (2/4/6 identification) of the SP/LP/EP modes of reproducing tapes, the TMRU-1 (CFG dividing circuit), TMRU-2 (capturing function/without reloading function) and TMRU-3 (DVCTL dividing circuit) of the Timer R should be used.

The Timer R will become to the aforementioned status after a reset.

Under the aforementioned status, the divided CFG should be written into the reloading register of the TMRU-1 and divided DVCTL should be written into the reloading register of the TMRU-3.

When the TMRU-3 underflows, the counter value of the TMRU-2 is captured. Such capturing register value represents the number of the CFG within the DVCTL cycle.

As aforementioned, the Timer R can work to count the number of the CFG corresponding to "n" times of DVCTL's or to identify the mode being searched.

- Exemplary settings

- (1) Setting the timer R mode register 1 (TMRM1)

CLR2 bit (Bit 7) = 1: Works to clear after making the TMRU-2 capture.

RLD bit (Bit 5) = 0: Sets the TMRU-3 without reloading function.

PS21 and PS20 (Bits 3 and 2) = (0 and 0): The underflowing signals of the TMRU-1 are to be used as the clock source for the TMRU-2.

RLD/CAP bit (Bit 1) = 0: The TMRU-1 has been set to make the reload timer operation.

- (2) Setting the timer R mode register 2 (TMRM2)

LAT bit (Bit 7) = 0: The underflowing signals of the TMRU-3 are to be used as the capture signal for the TMRU-2.

PS11 and PS10 (Bits 6 and 5) = (0 and 0): The leading edge of the CFG signal is to be used as the clock source for the TMRU-1.

PS31 and PS30 (Bits 4 and 3) = (0 and 0): The leading edge of the DVCTL signal is to be used as the clock source for the TMRU-3.

CP/SLM bit (Bit 2) = 0: The capture signal is to work to issue the TMRI3 interrupt request.

- (3) Setting the timer R load register 1 (TMRL1)

Set the dividing value for the CFG. The set value should become (n - 1) when divided by "n".

- (4) Setting the timer R load register 3 (TMRL3)

Set the dividing value for the DVCTL. The set value should become (n - 1) when divided by "n".

### 16.5.2 Reeling Controls

CFG counts can be captured by making 16-bit capturing operation combining the TMRU-1 and TMRU-2. By choosing the IRQ3 as the capture signal, and by counting the CFG within the duration of the reel pulse being input through the  $\overline{\text{IRQ3}}$  pin, reeling controls, etc. can be effected.

- Exemplary settings
  - (1) Setting P13/ $\overline{\text{IRQ3}}$  pin as the  $\overline{\text{IRQ3}}$  pin

Set the PMR13 bit (Bit 3) of the port mode register 1 (PMR1) to 1. See section 22.2.3, Port Mode Register 1 (PMR1).
  - (2) Setting the timer R mode register 1 (TMRM1)

CLR2 bit (Bit 7) = 1: Works to clear after making the TMRU-2 capture.  
PS21 and PS20 (Bits 3 and 2) = (0 and 0): The underflowing signals of the TMRU-1 are to be used as the clock source for the TMRU-2.  
RLD/CAP bit (Bit 1) = 1: The TMRU-1 has been set to make the capturing operation.  
CPS bit (Bit 0) = 1: The edge of the IRQ3 signal is to be used as the capture signal for the TMRU-1 and TMRU-2.
  - (3) Setting the timer R mode register 2 (TMRM2)

LAT bit (Bit 7) = 1: The edge of the IRQ3 signal is to be used as the capture signal for the TMRU-1 and TMRU-2.  
PS11 and PS10 (Bits 6 and 5) = (0 and 0): The rising edge of the CFG signal is to be used as the clock source for the TMRU-1.  
CP/SLM bit (Bit 2) = 0: The capture signal is to work to issue the TMRI3 interrupt request.

### 16.5.3 Slow Tracking Mono-Multi Function

When performing slow reproductions or still reproductions, the braking timing for the capstan motor is determined by use of the edge of the DVCTL signal. The slow tracking mono-multi function works to measure the time from the leading edge of the DVCTL signal down to the desired point to issue the interrupt request. In actual programming, this interrupt should be used to activate the brake of the capstan motor. The TMRU-3 should be used to perform time measurements for the slow tracking mono-multi function. Also, the braking process can be made using the TMRU-2.

- Exemplary settings
  - (1) Setting the timer R mode register 2 (TMRM2)

PS31 and PS30 (Bits 4 and 3) = Other than (0, 0): The dividing clock is to be used as the clock source for the TMRU-3.

CP/SLM bit (Bit 2) = 1: The slow tracking delay signal is to work to issue the TMRI3 interrupt request.

(2) Setting the timer R load register 3 (TMRL3)

Set the slow tracking delay value. When the delay count is "n", the set value should be (n - 1).

Regarding the delaying duration, see figure 16.2 Exemplary time series movements when a slow reproduction is being performed.

#### 16.5.4 Acceleration and Braking Processes of the Capstan Motor

When making intermittent movements such as those for slow reproductions or for still reproductions, it is necessary to conduct quick accelerations and abrupt stoppings of the capstan motor. The acceleration and braking processes will function to check if the revolution of a capstan motor has reached the prescribed rate when accelerated or braked. For this purpose, the TMRU-2 (reloading function) should be used.

The acceleration and braking processes should be employed when making special reproductions, in combination with the slow tracking mono-multi function.

- Exemplary settings for the acceleration process

(1) Setting the timer R mode register 1 (TMRM1)

AC/BR bit (Bit 6) = 1: Acceleration process

RLD bit (Bit 5) = 1: The TMRU-2 is to be used as the reload timer.

RLCK bit (Bit 4) = 0: The TMRU-2 is to reload at the rising edge of the CFG.

PS21 and PS20 (Bits 3 and 2) = Other than (0, 0): The dividing clock is to be used as the clock source for the TMRU-2.

(2) Setting the timer R load register 2 (TMRL2)

Set the count reading for the duration until the acceleration process finishes. When the count is "n", the set value should be (n - 1).

Regarding the duration until the acceleration process finishes, see figure 16.2 Exemplary time series movements when a slow reproduction is being performed.

- Exemplary settings for the braking process

(1) Setting the timer R mode register 1 (TMRM1)

AC/BR bit (Bit 6) = 0: Braking process

RLD bit (Bit 5) = 1: The TMRU-2 is to be used as the reload timer.

RLCK bit (Bit 4) = 0: The TMRU-2 is to reload at the rising edge of the CFG.

PS21 and PS20 (Bits 3 and 2) = Other than (0, 0): The dividing clock is to be used as the clock source for the TMRU-2.

(2) Setting the timer R load register 2 (TMRL2)

Set the count reading for the duration until the braking process finishes. When the count is "n", the set value should be (n - 1).

Regarding the duration until the braking process finishes, see figure 16.2 Exemplary time series movements when a slow reproduction is being performed.

## Section 17 Timer X1

### 17.1 Overview

The Timer X1 is capable of outputting two different types of independent waveforms using the free running counter (FRC) as the basic means and it is also applicable to measurements of the durations of input pulses and the cycles external clocks.

#### 17.1.1 Features

Listed below are the features of the Timer X1.

- Choices of 4 different types of counter inputting clocks are available for your selection.  
You can select from among three different types of internal clocks ( $\phi/4$ ,  $\phi/16$ , and  $\phi/64$ ) and the DVCFG.
- Two independent output comparing functions  
Capable of outputting two different types of independent waveforms.
- Four independent input capturing functions  
The rising edge or falling edge can be selected for use. The buffer operation can also be designated.
- Counter clearing designation is workable.  
The counter readings can be cleared by compare match A.
- Seven types of interrupt causes  
Comparing match  $\times 2$  causes, input capture  $\times 4$  causes, and overflow  $\times 1$  cause are available for use and they can make respective interrupt requests independently.

#### 17.1.2 Block Diagram

Figure 17.1 shows a block diagram of the Timer X1.

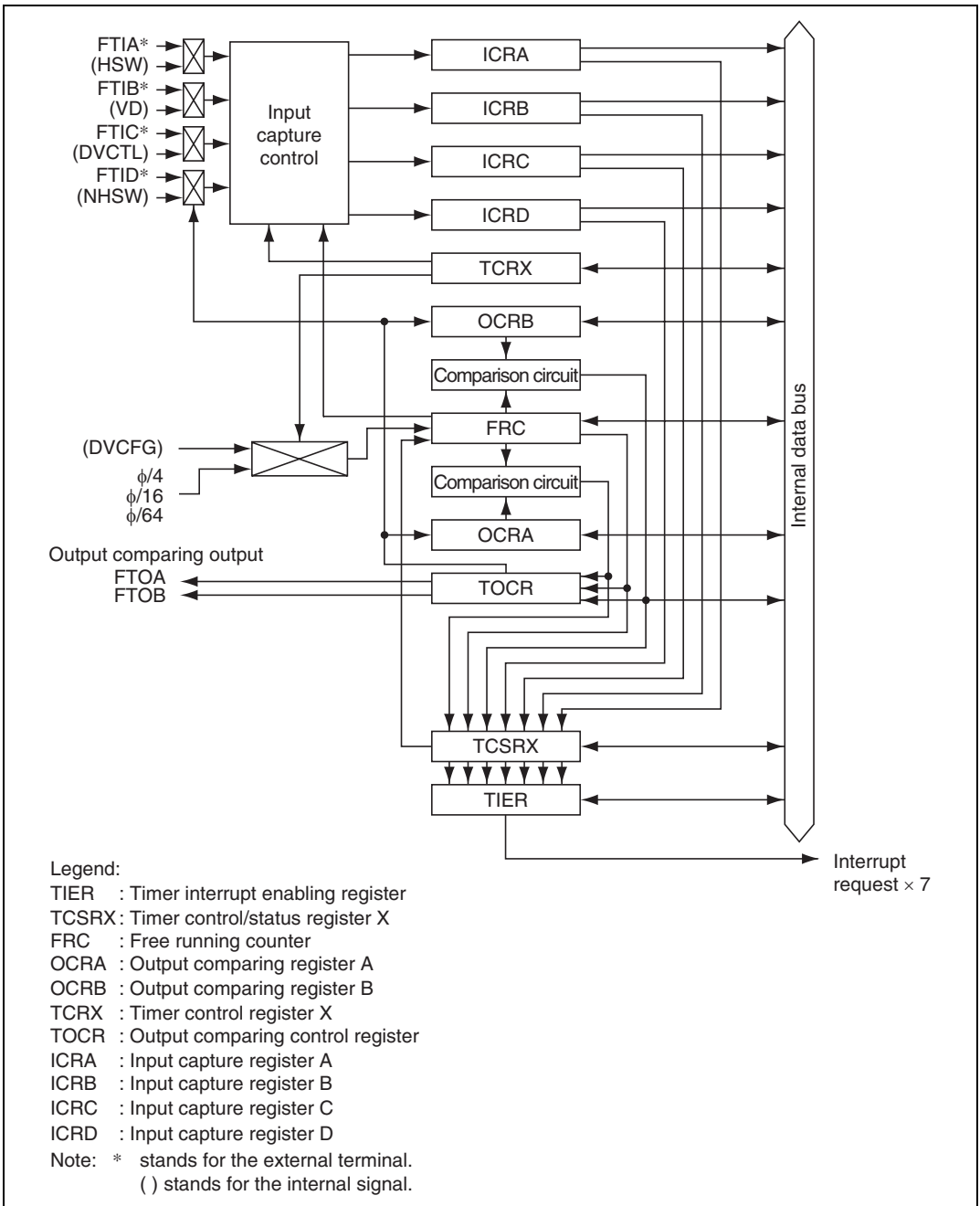


Figure 17.1 Block Diagram of the Timer X1

### 17.1.3 Pin Configuration

Table 17.1 shows the pin configuration of the Timer X1.

**Table 17.1 Pin Configuration**

<b>Name</b>	<b>Abbrev.</b>	<b>I/O</b>	<b>Function</b>
Output comparing A output-pin	FTOA	Output	Output pin for the output comparing A
Output comparing B output-pin	FTOB	Output	Output pin for the output comparing B
Input capture A input-pin	FTIA	Input	Input-pin for the input capture A
Input capture B input-pin	FTIB	Input	Input-pin for the input capture B
Input capture C input-pin	FTIC	Input	Input-pin for the input capture C
Input capture D input-pin	FTID	Input	Input-pin for the input capture D

### 17.1.4 Register Configuration

Table 17.2 shows the register configuration of the Timer X1.

**Table 17.2 Register Configuration**

Name	Abbrev.	R/W	Initial Value	Address <sup>*3</sup>
Timer interrupt enabling register	TIER	R/W	H'00	H'D100
Timer control/status register X	TCSRX	R/ (W) <sup>*1</sup>	H'00	H'D101
Free running counter H	FRCH	R/W	H'00	H'D102
Free running counter L	FRCL	R/W	H'00	H'D103
Output comparing register AH	OCRAH	R/W	H'FF	H'D104 <sup>*2</sup>
Output comparing register AL	OCRAL	R/W	H'FF	H'D105 <sup>*2</sup>
Output comparing register BH	OCRBH	R/W	H'FF	H'D104 <sup>*2</sup>
Output comparing register BL	OCRBL	R/W	H'FF	H'D105 <sup>*2</sup>
Timer control register X	TCRX	R/W	H'00	H'D106
Timer output comparing control register	TOCR	R/W	H'00	H'D107
Input capture register AH	ICRAH	R	H'00	H'D108
Input capture register AL	ICRAL	R	H'00	H'D109
Input capture register BH	ICRBH	R	H'00	H'D10A
Input capture register BL	ICRBL	R	H'00	H'D10B
Input capture register CH	ICRCH	R	H'00	H'D10C
Input capture register CL	ICRCL	R	H'00	H'D10D
Input capture register DH	ICRDH	R	H'00	H'D10E
Input capture register DL	ICRDL	R	H'00	H'D10F

- Notes:
1. Only 0 can be written to clear the flag for Bits 7 to 1. Bit 0 is readable/writable.
  2. The addresses of the OCRA and OCRB are the same. Changeover between them are to be made by use of the TOCR bit and OCRS bit.
  3. Lower 16 bits of the address.

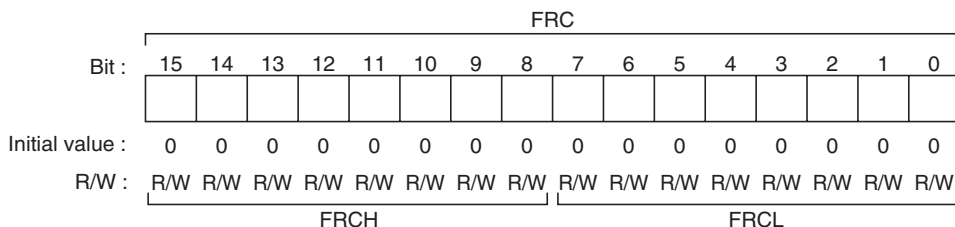


## 17.2 Descriptions of Respective Registers

### 17.2.1 Free Running Counter (FRC)

Free running counter H (FRCH)

Free running counter L (FRCL)



The FRC is a 16-bit read/write up-counter which counts up by the inputting internal clock/external clock. The inputting clock is to be selected from the CKS1 and CKS0 of the TCRX.

By the setting of the CCLRA bit of the TCSRX, the FRC can be cleared by comparing match A.

When the FRC overflows (H'FFFF → H'0000), the OVF of the TCSRX will be set to 1.

At this time, when the OVIE of the TIER is being set to 1, an interrupt request will be issued to the CPU.

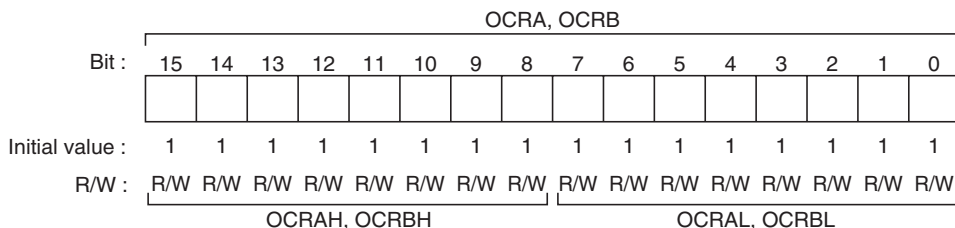
Reading/writing can be made from and to the FRC through the CPU at 8-bit or 16-bit.

The FRC is initialized to H'0000 when reset or under the standby mode, watch mode, subsleep mode, module stop mode or subactive mode.

### 17.2.2 Output Comparing Register A and B (OCRA and OCRB)

Output comparing register AH and BH (OCRAH and OCRBH)

Output comparing register AL and BL (OCRAL and OCRBL)



The OCR consists of twin 8-bit read/write registers (OCRA and OCRB). The contents of the OCR are always being compared with the FRC and, when the value of these two match, the OCFA and OCRB of the TCSRX will be set to 1. At this time, if the OCIAE and OCIB of the TIER are being set to 1, an interrupt request will be issued to the CPU.

When performing compare matching, if the OEA and OEB of the TOCR are being set to 1, the level value having been set to the OLVLA and OLVLB of the TOCR will be output through the FTOA and FTOB pins. After resetting, 0 will be output through the FTOA and FTOB pins until the first compare matching occurs.

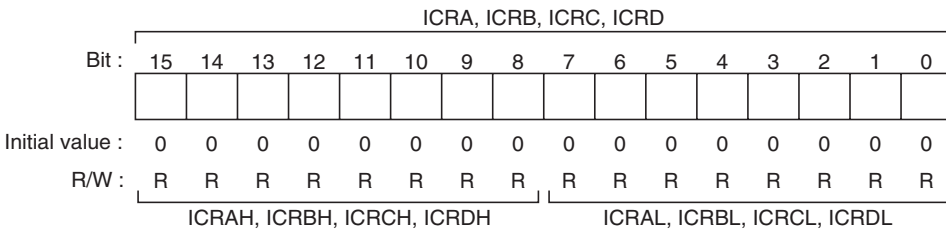
Reading/writing can be made from and to the OCR through the CPU at 8-bit or 16-bit.

The OCR is cleared to H'FFFF when reset or under the standby mode, watch mode, subsleep mode, module stop mode or subactive mode.

### 17.2.3 Input Capture Register A Through D (ICRA Through ICRD)

Input capture register AH to DH (ICRAH to ICRDH)

Input capture register AL to DL (ICRAL to ICRDL)

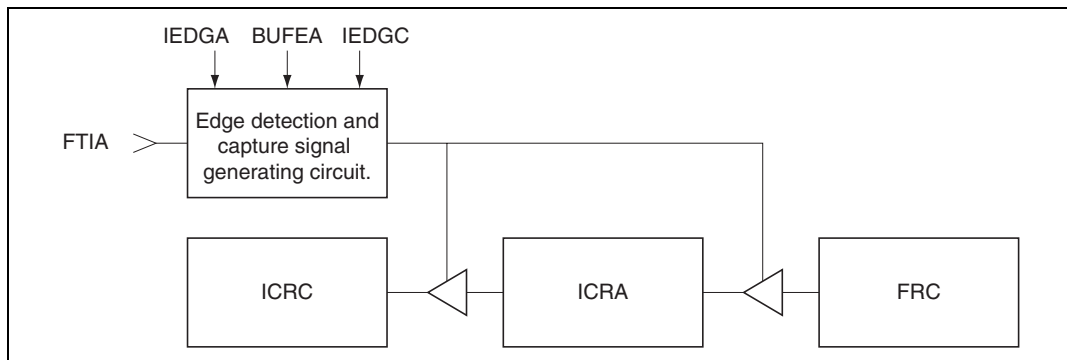


The ICR consists of four 16-bit read only registers (ICRA through ICRD).

When the falling edge of the input capture input signal is detected, the value is transferred to the ICRA through ICRD. At this time, the ICFA through ICFD of the TCSRX are set to 1 simultaneously. At this time, if the IDIAE through IDIDE of the TCRX are all being set to 1, due interrupt request will be issued to the CPU. The edge of the input signal can be selected by setting the IEDGA through IEDGD of the TCRX.

Also, the ICRC and ICRD can be used as the buffer register, respectively, of the ICRA and ICRB by setting the BUFEA and BUFEB of the TCRX to perform buffer operations. Figure 17.2 shows the connections necessary when using the ICRC as the buffer register of the ICRA. (BUFEA = 1) When the ICRC is used as the buffer of the ICRA, by setting IEDGA ≠ IEDGC, both of the rising and falling edges can be designated for use. In case of IEDGA = IEDGC, either one of the rising edge or the falling edge only is usable. Regarding selection of the input signal edge, see table 17.3.

Note: Transference from the FRC to the ICR will be performed regardless of the value of the ICF.



**Figure 17.2 Buffer Operation (an Example)**

**Table 17.3 Input Signal Edge Selection when Making Buffer Operation**

IEDGA	IEDGC	Selection of the Input Signal Edge
0	0	Captures at the rising edge of the input capture input A (Initial value)
	1	Captures at both rising and falling edges of the input capture input A
1	0	
	1	Captures at the rising edge of the input capture input A

Reading can be made from the ICR through the CPU at 8-bit or 16-bit.

For stable input capturing operation, maintain the pulse duration of the input capture input signals at 1.5 system clock ( $\phi$ ) or more in case of single edge capturing and at 2.5 system clock ( $\phi$ ) or more in case of both edge capturing.

The ICR is initialized to H'0000 when reset or under the standby mode, watch mode, subsleep mode, module stop mode, or subactive mode.

### 17.2.4 Timer Interrupt Enabling Register (TIER)

Bit :	7	6	5	4	3	2	1	0
	ICIAE	ICIBE	ICICE	ICIDE	OCIAE	OCIBE	OVIE	ICSA
Initial value :	0	0	0	0	0	0	0	0
R/W :	R/W	R/W	R/W	R/W	R/W	R/W	R/W	R/W

The TIER is an 8-bit read/write register which works to control permission/prohibition of respective interrupt requests.

The TIER is initialized to H'00 when reset or under the standby mode, watch mode, subsleep mode, module stop mode or subactive mode.

**Bit 7—Enabling the Input Capture Interrupt A (ICIAE):** This bit works to permit/prohibit interrupt requests (ICIA) by the ICFA when the ICFA of the TCSRX is being set to 1.

#### Bit 7

ICIAE	Description
0	Prohibits interrupt requests (ICIA) by the ICFA (Initial value)
1	Permits interrupt requests (ICIA) by the ICFA

**Bit 6—Enabling the Input Capture Interrupt B (ICIBE):** This bit works to permit/prohibit interrupt requests (ICIB) by the ICFB when the ICFB of the TCSRX is being set to 1.

#### Bit 6

ICIBE	Description
0	Prohibits interrupt requests (ICIB) by the ICFB (Initial value)
1	Permits interrupt requests (ICIB) by the ICFB

**Bit 5—Enabling the Input Capture Interrupt C (ICICE):** This bit works to permit/prohibit interrupt requests (ICIC) by the ICFC when the ICFC of the TCSRX is being set to 1.

#### Bit 5

ICICE	Description
0	Prohibits interrupt requests (ICIC) by the ICFC (Initial value)
1	Permits interrupt requests (ICIC) by the ICFC

**Bit 4—Enabling the Input Capture Interrupt D (ICIDE):** This bit works to permit/prohibit interrupt requests (ICID) by the ICFD when the ICFD of the TCSRX is being set to 1.

**Bit 4**

ICIDE	Description
0	Prohibits interrupt requests (ICID) by the ICFD (Initial value)
1	Permits interrupt requests (ICID) by the ICFD

**Bit 3—Enabling the Output Comparing Interrupt A (OCIAE):** This bit works to permit/prohibit interrupt requests (OCIA) by the OCFA when the OCFA of the TCSRX is being set to 1.

**Bit 3**

OCIAE	Description
0	Prohibits interrupt requests (OCIA) by the OCFA (Initial value)
1	Permits interrupt requests (OCIA) by the OCFA

**Bit 2—Enabling the Output Comparing Interrupt B (OCIBE):** This bit works to permit/prohibit interrupt requests (OCIB) by the OCFB when the OCFB of the TCSRX is being set to 1.

**Bit 2**

OCIBE	Description
0	Prohibits interrupt requests (OCIB) by the OCFB (Initial value)
1	Permits interrupt requests (OCIB) by the OCFB

**Bit 1—Enabling the Timer Overflow Interrupt (OVIE):** This bit works to permit/prohibit interrupt requests (FOVI) by the OVF when the OVF of the TCSRX is being set to 1.

**Bit 1**

OVIE	Description
0	Prohibits interrupt requests (FOVI) by the OVF (Initial value)
1	Permits interrupt requests (FOVI) by the OVF

**Bit 0—Selecting the Input Capture A Signals (ICSA):** This bit works to select the input capture A signals.

**Bit 0**

ICSA	Description
0	Selects the FTIA pin for inputting of the input capture A signals (Initial value)
1	Selects the HSW for inputting of the input capture A signals

**17.2.5 Timer Control/Status Register X (TCSRX)**

Bit :	7	6	5	4	3	2	1	0
	ICFA	ICFB	ICFC	ICFD	OCFA	OCFB	OVF	CCLRA

Initial value : 0 0 0 0 0 0 0 0

R/W : R/(W)\* R/(W)\* R/(W)\* R/(W)\* R/(W)\* R/(W)\* R/(W)\* R/W

Note: \* Only 0 can be written to clear the flag for bits 7 to 1.

The TCSRX is an 8-bit register which works to select counter clearing timing and to control respective interrupt requesting signals. The TCSRX is initialized to H'00 when reset or under the standby mode, watch mode, subsleep mode, module stop mode or subactive mode.

Meanwhile, as for the timing, see section 17.3, Operation.

The FTIA through FTID pins are for fixed inputs inside the LSI under the low power consumption mode excluding the sleep mode. Consequently, when such shifts as "active mode → low power consumption mode → active mode" are made, wrong edges may be detected depending on the pin status or on the type of the detecting edge.

To avoid such error, clear the interrupt requesting flag once immediately after shifting to the active mode from the low power consumption mode.

**Bit 7—Input Capture Flag A (ICFA):** This is a status flag indicating the fact that the value of the FRC has been transferred to the ICRA by the input capture signals.

When the BUFEA of the TCRX is being set to 1, the ICFA indicates the status that the FRC value has been transferred to the ICRA by the input capture signals and that the ICRA value before being updated has been transferred to the ICRC.

This flag should be cleared by use of the software. Such setting should only be made by use of the hardware. It is not possible to make this setting using a software.

#### Bit 7

ICFA	Description
0	[Clearing condition] (Initial value) When 0 is written into the ICFA after reading the ICFA under the setting of ICFA = 1
1	[Setting condition] When the value of the FRC has been transferred to the ICRA by the input capture signals

**Bit 6—Input Capture Flag B (ICFB):** This is a status flag indicating the fact that the value of the FRC has been transferred to the ICRB by the input capture signals.

When the BUFEA of the TCRX is being set to 1, the ICFB indicates the status that the FRC value has been transferred to the ICRB by the input capture signals and that the ICRB value before being updated has been transferred to the ICRC.

This flag should be cleared by use of the software. Such setting should only be made by use of the hardware. It is not possible to make this setting using a software.

#### Bit 6

ICFB	Description
0	[Clearing condition] (Initial value) When 0 is written into the ICFB after reading the ICFB under the setting of ICFB = 1
1	[Setting condition] When the value of the FRC has been transferred to the ICRB by the input capture signals

**Bit 5—Input Capture Flag C (ICFC):** This is a status flag indicating the fact that the value of the FRC has been transferred to the ICRC by the input capture signals.

When an input capture signal occurs while the BUFEA of the TCRX is being set to 1, although the ICFC will be set out, data transference to the ICRC will not be performed.

Therefore, in buffer operation, the ICFC can be used as an external interrupt by setting the ICICE bit to 1.

This flag should be cleared by use of the software. Such setting should only be made by use of the hardware. It is not possible to make this setting using a software.

#### Bit 5

ICFC	Description
0	[Clearing condition] (Initial value) When 0 is written into the ICFC after reading the ICFC under the setting of ICFC = 1
1	[Setting condition] When the input capture signal has occurred

**Bit 4—Input Capture Flag D (ICFD):** This is a status flag indicating the fact that the value of the FRC has been transferred to the ICRD by the input capture signals.

When an input capture signal occurs while the BUFEA of the TCRX is being set to 1, although the ICFD will be set out, data transference to the ICRD will not be performed.

Therefore, in buffer operation, the ICFD can be used as an external interrupt by setting the ICIDE bit to 1.

This flag should be cleared by use of the software. Such setting should only be made by use of the hardware. It is not possible to make this setting using a software.

#### Bit 4

ICFD	Description
0	[Clearing condition] (Initial value) When 0 is written into the ICFD after reading the ICFD under the setting of ICFD = 1
1	[Setting condition] When the input capture signal has occurred



**Bit 3—Output Comparing Flag A (OCFA):** This is a status flag indicating the fact that the FRC and the OCRA have come to a comparing match.

This flag should be cleared by use of the software. Such setting should only be made by use of the hardware. It is not possible to make this setting using a software.

### Bit 3

OCFA	Description
0	[Clearing condition] (Initial value) When 0 is written into the OCFA after reading the OCFA under the setting of OCFA = 1
1	[Setting condition] When the FRC and the OCRA have come to the comparing match

**Bit 2—Output Comparing Flag B (OCFB):** This is a status flag indicating the fact that the FRC and the OCRB have come to a comparing match.

This flag should be cleared by use of the software. Such setting should only be made by use of the hardware. It is not possible to make this setting using a software.

### Bit 2

OCFB	Description
0	[Clearing condition] (Initial value) When 0 is written into the OCFB after reading the OCFB under the setting of OCFB = 1
1	[Setting condition] When the FRC and the OCRB have come to the comparing match

**Bit 1—Time Over Flow (OVF):** This is a status flag indicating the fact that the FRC overflowed. (H'FFFF → H'0000).

This flag should be cleared by use of the software. Such setting should only be made by use of the hardware. It is not possible to make this setting using a software.

### Bit 1

OVF	Description
0	[Clearing condition] (Initial value) When 0 is written into the OVF after reading the OVF under the setting of OVF = 1
1	[Setting condition] When the FRC value has become H'FFFF → H'0000

**Bit 0—Counter Clearing (CCLRA):** This bit works to select if or not to clear the FRC by occurrence of comparing match A (matching signal of the FRC and OCRA).

**Bit 0**

CCLRA	Description
0	Prohibits clearing of the FRC by occurrence of comparing match A (Initial value)
1	Permits clearing of the FRC by occurrence of comparing match A

**17.2.6 Timer Control Register X (TCRX)**

Bit :	7	6	5	4	3	2	1	0
	IEDGA	IEDGB	IEDGC	IEDGD	BUFEA	BUFEB	CKS1	CKS0
Initial value :	0	0	0	0	0	0	0	0
R/W :	R/W	R/W	R/W	R/W	R/W	R/W	R/W	R/W

The TCRX is an 8-bit read/write register which works to select the input capture signal edge, to designate the buffer operation and to select the inputting clock for the FRC.

The TCRX is initialized to H'00 when reset or under the standby mode, watch mode, subsleep mode, module stop mode or subactive mode.

**Bit 7—Input Capture Signal Edge Selection A (IEDGA):** This bit works to select the rising edge or falling edge of the input capture signal A (FTIA).

**Bit 7**

IEDGA	Description
0	Captures the falling edge of the input capture signal A (Initial value)
1	Captures the rising edge of the input capture signal A

**Bit 6—Input Capture Signal Edge Selection B (IEDGB):** This bit works to select the rising edge or falling edge of the input capture signal B (FTIB).

**Bit 6**

IEDGB	Description
0	Captures the falling edge of the input capture signal B (Initial value)
1	Captures the rising edge of the input capture signal B

**Bit 5—Input Capture Signal Edge Selection C (IEDGC):** This bit works to select the rising edge or falling edge of the input capture signal C (FTIC). However, when the DVCTL has been selected as the signal for the input capture signal edge selection C, this bit will not influence the operation.

**Bit 5**

<b>IEDGC</b>	<b>Description</b>
0	Captures the falling edge of the input capture signal C (Initial value)
1	Captures the rising edge of the input capture signal C

**Bit 4—Input Capture Signal Edge Selection D (IEDGD):** This bit works to select the rising edge or falling edge of the input capture signal D (FTID).

**Bit 4**

<b>IEDGD</b>	<b>Description</b>
0	Captures the falling edge of the input capture signal D (Initial value)
1	Captures the rising edge of the input capture signal D

**Bit 3—Buffer Enabling A (BUFEA):** This bit works to select if or not to use the ICRC as the buffer register for the ICRA.

**Bit 3**

<b>BUFEA</b>	<b>Description</b>
0	Using the ICRC as the buffer register for the ICRA (Initial value)
1	Not using the ICRC as the buffer register for the ICRA

**Bit 2—Buffer Enabling B (BUFEB):** This bit works to select if or not to use the ICRD as the buffer register for the ICRB.

**Bit 2**

<b>BUFEB</b>	<b>Description</b>
0	Using the ICRD as the buffer register for the ICRB (Initial value)
1	Not using the ICRD as the buffer register for the ICRB

**Bits 1 and 0—Clock Select (CKS1, 0):** These bits work to select the inputting clock to the FRC from among three types of internal clocks and the DVCFG.

The DVCFG is the edge detecting pulse selected by the CFG dividing timer.

Bit 1	Bit 0	Description
CKS1	CKS0	
0	0	Internal clock: Counts at $\phi/4$ (Initial value)
0	1	Internal clock: Counts at $\phi/16$
1	0	Internal clock: Counts at $\phi/64$
1	1	DVCFG: The edge detecting pulse selected by the CFG dividing timer

### 17.2.7 Timer Output Comparing Control Register (TOCR)

Bit :	7	6	5	4	3	2	1	0
	ICSB	ICSC	ICSD	OSRS	OEA	OEB	OLVLA	OLVLB
Initial value :	0	0	0	0	0	0	0	0
R/W :	R/W	R/W	R/W	R/W	R/W	R/W	R/W	R/W

The TOCR is an 8-bit read/write register which works to select input capture signals and output comparing output level, to permit output comparing outputs and to control switching over of the access of the OCRA and OCRB. See the section 17.2.4, Timer Interrupt Enabling Register (TIER) regarding the input capture inputs A.

The TOCR is initialized to H'00 when reset or under the standby mode, watch mode, subsleep mode, module stop mode or subactive mode.

**Bit 7—Selecting the Input Capture B Signals (ICSB):** This bit works to select the input capture B signals.

Bit 7	Description
ICSB	
0	Selects the FTIB pin for inputting of the input capture B signals (Initial value)
1	Selects the VD as the input capture B signals

**Bit 6—Selecting the Input Capture C Signals (ICSC):** This bit works to select the input capture C signals. The DVCTL is the edge detecting pulse selected by the CTL dividing timer.

**Bit 6**

ICSC	Description
0	Selects the FTIC pin for inputting of the input capture C signals (Initial value)
1	Selects the DVCTL as the input capture C signals

**Bit 5—Selecting the Input Capture D Signals (ICSD):** This bit works to select the input capture D signals.

**Bit 5**

ICSD	Description
0	Selects the FTID pin for inputting of the input capture D signals (Initial value)
1	Selects the NHSW as the input capture D signals

**Bit 4—Selecting the Output Comparing Register (OCRS):** The addresses of the OCRA and OCRB are the same. The OCRS works to control which register to choose when reading/writing this address. The choice will not influence the operation of the OCRA and OCRB.

**Bit 4**

OCRS	Description
0	Selects the OCRA register (Initial value)
1	Selects the OCRB register

**Bit 3—Enabling the Output A (OEA):** This bit works to control the output comparing A signals.

**Bit 3**

OEA	Description
0	Prohibits the output comparing A signal outputs (Initial value)
1	Permits the output comparing A signal outputs

**Bit 2—Enabling the Output B (OEB):** This bit works to control the output comparing B signals.

**Bit 2**

OEB	Description
0	Prohibits the output comparing B signal outputs (Initial value)
1	Permits the output comparing B signal outputs

---

**Bit 1—Output Level A (OLVLA):** This bit works to select the output level to output through the FTOA pin by use of the comparing match A (matching signal between the FRC and OCRA).

**Bit 1**

OLVLA	Description
0	Low level (Initial value)
1	High level

---

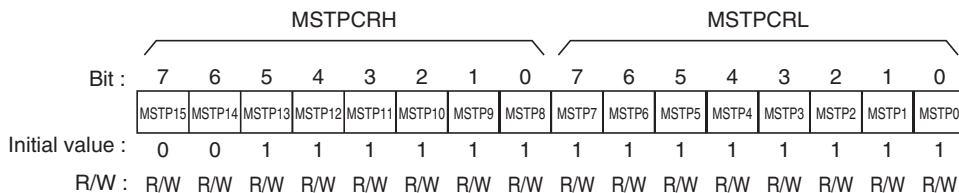
**Bit 0—Output Level B (OLVLB):** This bit works to select the output level to output through the FTOB pin by use of the comparing match B (matching signal between the FRC and OCRB).

**Bit 0**

OLVLB	Description
0	Low level (Initial value)
1	High level

---

## 17.2.8 Module Stop Control Register (MSTPCR)



The MSTPCR consists of twin 8-bit read/write registers and it works to control the module stop mode.

When the MSTP10 bit is set to 1, the Timer X1 stops its operation at the ending point of the bus cycle to shift to the module stop mode. For more information, see section 4.5, Module Stop Mode. When reset, the MSTPCR is initialized to H'FFFF.

**Bit 2—Module Stop (MSTP10):** This bit works to designate the module stop mode for the Timer X1.

### MSTPCR<sub>H</sub>

#### Bit 2

MSTP10	Description
0	Cancels the module stop mode of the Timer X1
1	Sets the module stop mode of the Timer X1 <span style="float: right;">(Initial value)</span>

## 17.3 Operation

### 17.3.1 Operation of the Timer X1

#### (1) Output Comparing Operation

Right after resetting, the FRC is initialized to H'0000 to start counting up. The inputting clock can be selected from among three different types of internal clocks or the external clock by setting the CKS1 and CKS0 of the TCRX.

The contents of the FRC are always being compared with the OCRA and OCRB and, when the value of these two match, the level set by the the OLVLA and OLVLB of the TOCR is output through the FTOA pin and FTOB pin.

After resetting, 0 will be output through the FTOA and FTOB pins until the first compare matching occurs.

Also, when the CCLRA of the TCSRX is being set to 1, the FRC will be cleared to H'0000 when the comparing match A occurs.

#### (2) Input Capturing Operation

Right after resetting, the FRC is initialized to H'0000 to start counting up. The inputting clock can be selected from among three different types of internal clocks or the external clock by setting the CKS1 and CKS0 of the TCRX.

The inputs are transferred to the IEDGA through IEDGD of the TCRX through the FTIA through FTID pins and, at the same time, the ICFA through ICFD of the TCSRX are set to 1. At this time, if the ICIAE through ICIED of the TIER are being set to 1, due interrupt request will be issued to the CPU.

When the BUFEA and BUFEB of the TCRX are set to 1, the ICRC and ICRD work as the buffer register, respectively, of the ICRA and ICRB. When the edge selected by setting the IEDGA through IEDGD of the TCRX is input through the FTIA and FTIB pins, the value at the time of the FRC is transferred to the ICRA and ICRB and, at the same time, the values of the ICRA and ICRB before updating are transferred to the ICRC and ICRD. At this time, when the ICFA and ICFB are being set to 1 and if the ICIAE and ICIBE of the TIER are being set to 1, due interrupt request will be issued to the CPU.

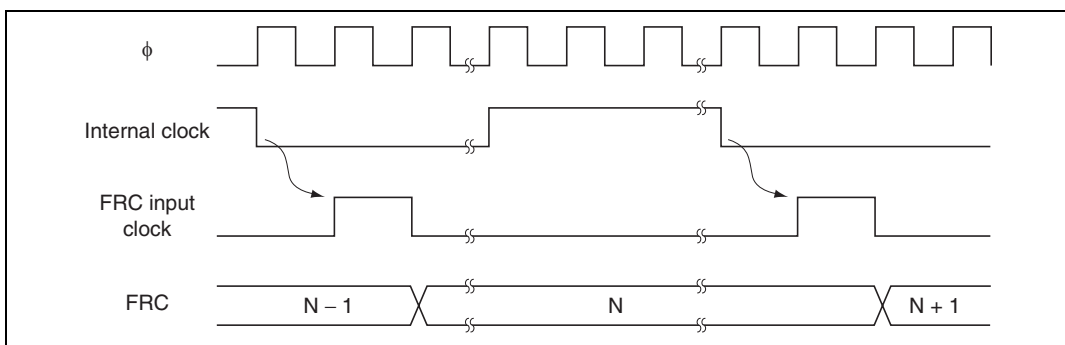


### 17.3.2 Counting Timing of the FRC

The FRC is counted up by the inputting clock. By setting the CKS1 and CKS0 of the TCRX, the inputting clock can be selected from among three different types of clocks ( $\phi/4$ ,  $\phi/16$ , and  $\phi/64$ ) and the DVCFG.

#### (1) In Case of Internal Clock Operation

By setting the CKS1 and CKS0 bits of the TCRX, three types of internal clocks ( $\phi/4$ ,  $\phi/16$ , and  $\phi/64$ ), generated by dividing the system clock ( $\phi$ ) can be selected. Figure 17.3 shows the timing chart at this time.

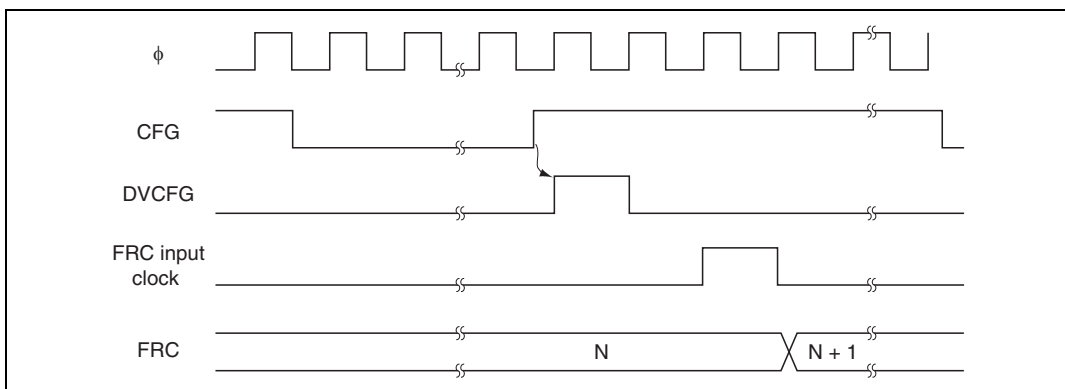


**Figure 17.3** Count Timing in Case of Internal Clock Operation

#### (2) In Case of DVCFG Clock Operation

By setting the CKS1 and CKS0 bits of the TCRX to 1, DVCFG clock input can be selected. The DVCFG clock makes counting by use of the edge detecting pulse being selected by the CFG dividing timer.

Figure 17.4 shows the timing chart at this time.



**Figure 17.4** Count Timing in Case of CFG Clock Operation

### 17.3.3 Output Comparing Signal Outputting Timing

When a comparing match occurs, the output level having been set by the OLVL of the TOCR is output through the output comparing signal outputting pins (FTOA and FTOB).

Figure 17.5 shows the timing chart in case of the output comparing signal outputting A.

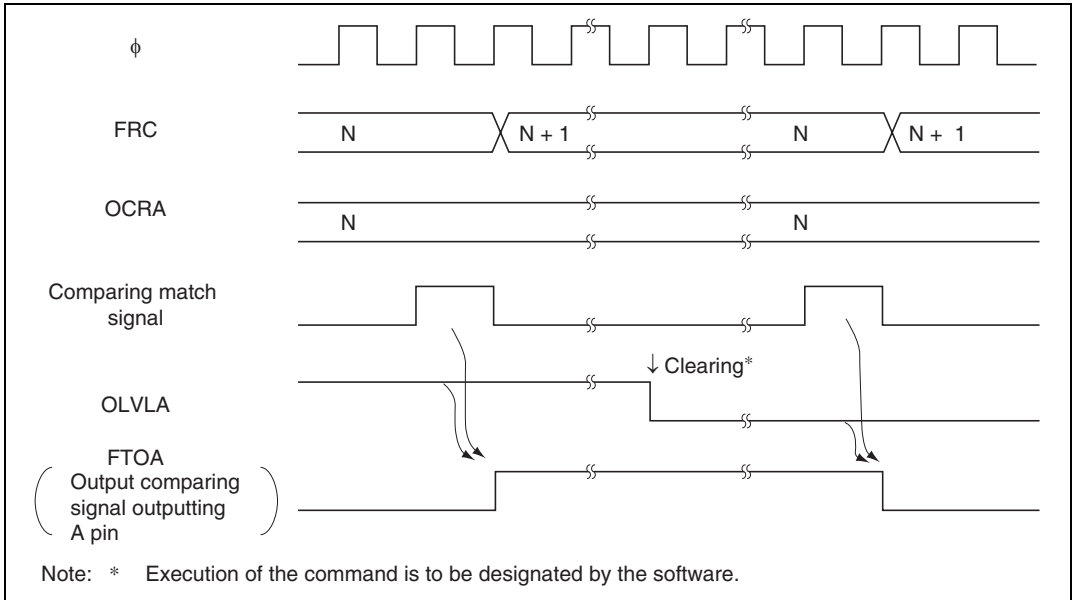


Figure 17.5 Output Comparing Signal Outputting A Timing

### 17.3.4 FRC Clearing Timing

The FRC can be cleared when the comparing match A occurs. Figure 17.6 shows the timing chart when doing so.

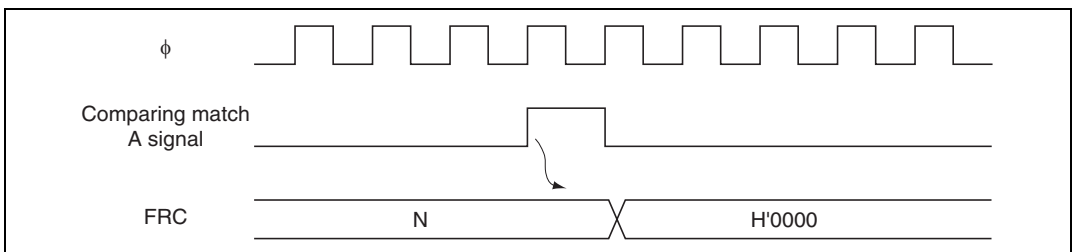


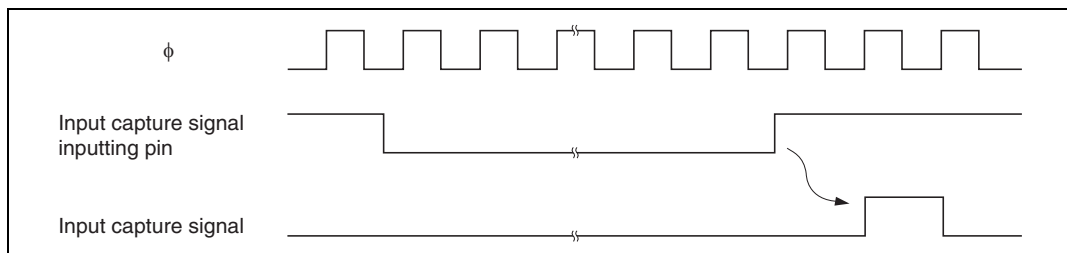
Figure 17.6 FRC Clearing Timing by Occurrence of the Comparing Match A

### 17.3.5 Input Capture Signal Inputting Timing

#### (1) Input Capture Signal Inputting Timing

As for the input capture signal inputting, rising or falling edge is selected by settings of the IEDGA through IEDGD bits of the TCRX.

Figure 17.7 shows the timing chart when the rising edge is selected (IEDGA through IEDGD = 1).

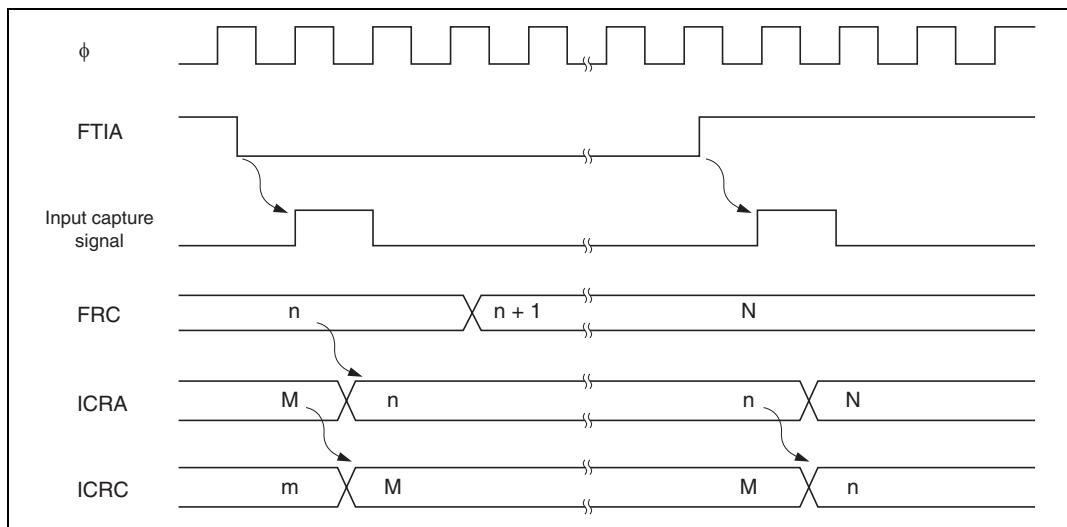


**Figure 17.7 Input Capture Signal Inputting Timing (Under Normal State)**

#### (2) Input Capture Signal Inputting Timing when Making Buffer Operation

Buffer operation can be made using the ICRA or ICRD as the buffer of the ICRA or ICRB.

Figure 17.8 shows the input capture signal inputting timing chart in case both of the rising and falling edges are designated (IEDGA = 1 and IEDGC = 0, or IEDGA = 0 and IEDGC = 1), using the ICRC as the buffer register for the ICRA (BUFEA = 1).



**Figure 17.8 Input Capture Signal Inputting Timing Chart under the Buffer Mode (Under Normal State)**

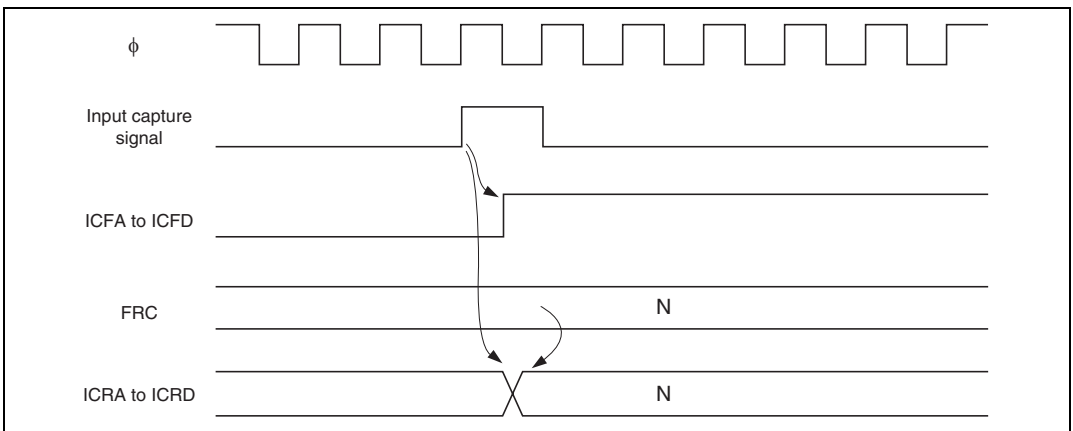
Even when the ICRC or ICRD is used as the buffer register, the input capture flag will be set up corresponding to the designated edge change of respective input capture signals.

For example, when using the ICRC as the buffer register for the ICRA, when an edge change having been designated by the IEDGC bit is detected with the input capture signals C and if the ICIEC bit is duly set, an interrupt request will be issued.

However, in this case, the FRC value will not be transferred to the ICRC.

### 17.3.6 Input Capture Flag (ICFA through ICFD) Setting Up Timing

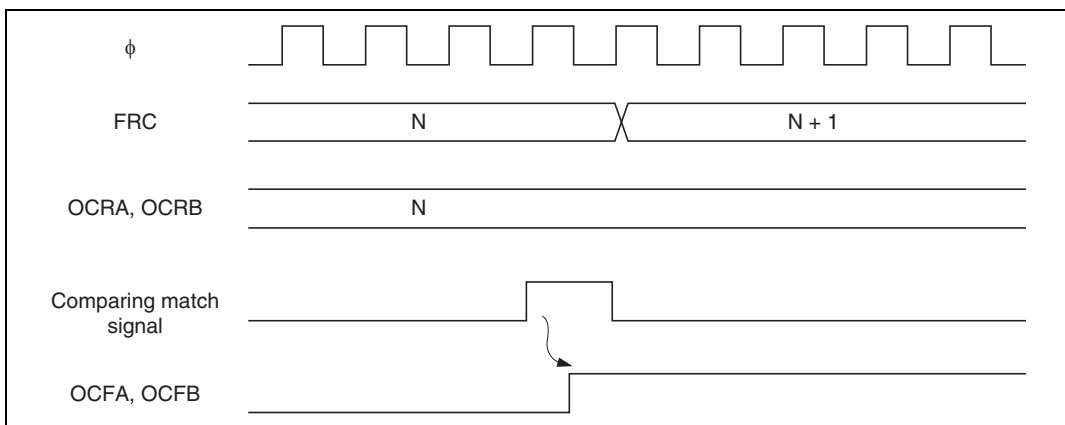
The input capture signal works to set the ICFA through ICFD to "1" and, simultaneously, the FRC value is transferred to the corresponding ICRA through ICRD. Figure 17.9 shows the timing chart for the above.



**Figure 17.9 ICFA through ICFD Setting Up Timing**

### 17.3.7 Output Comparing Flag (OCFA and OCFB) Setting Up Timing

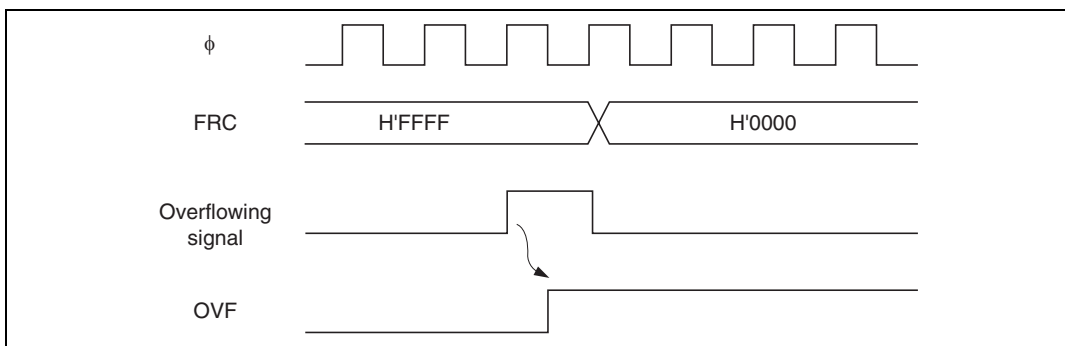
The OCFA and OCFB are being set to 1 by the comparing match signal being output when the values of the OCRA, OCRB, and FRC match. The comparing match signal is generated at the last state of the value match (the timing of the FRC's updating the matching count reading). After the values of the OCRA, OCRB, and FRC match, up until the count up clock signal is generated, the comparing match signal will not be issued. Figure 17.10 shows the OCFA and OCFB setting timing chart.



**Figure 17.10 OCF Setting Up Timing**

### 17.3.8 Overflow Flag (OVF) Setting Up Timing

The OVF is set to when the FRC overflows ( $H'FFFF \rightarrow H'0000$ ). Figure 17.11 shows the timing chart for this case.



**Figure 17.11 OVF Setting Up Timing**

## 17.4 Operation Mode of the Timer X1

Table 17.4 indicated below shows the operation mode of the Timer X1.


**Table 17.4 Operation Mode of the Timer X1**

Operation mode	Reset	Active	Sleep	Watch	Subactive	Standby	Subsleep	Module stop
FRC	Reset	Functions	Functions	Reset	Reset	Reset	Reset	Reset
OCRA, OCRB	Reset	Functions	Functions	Reset	Reset	Reset	Reset	Reset
ICRA to ICRD	Reset	Functions	Functions	Reset	Reset	Reset	Reset	Reset
TIER	Reset	Functions	Functions	Reset	Reset	Reset	Reset	Reset
TCRX	Reset	Functions	Functions	Reset	Reset	Reset	Reset	Reset
TOCR	Reset	Functions	Functions	Reset	Reset	Reset	Reset	Reset
TCSRX	Reset	Functions	Functions	Reset	Reset	Reset	Reset	Reset

## 17.5 Interrupt Causes

Total seven interrupt causes exist with the Timer X1, namely, ICIA through ICID, OCIA, OCIB, and FOVI. Table 17.5 given below lists the contents of respective interrupt causes. Respective interrupt requests can be permitted or prohibited by setting of respective interrupt enabling bits of the TIER. Also, independent vector addresses are being allocated to respective interrupt causes.

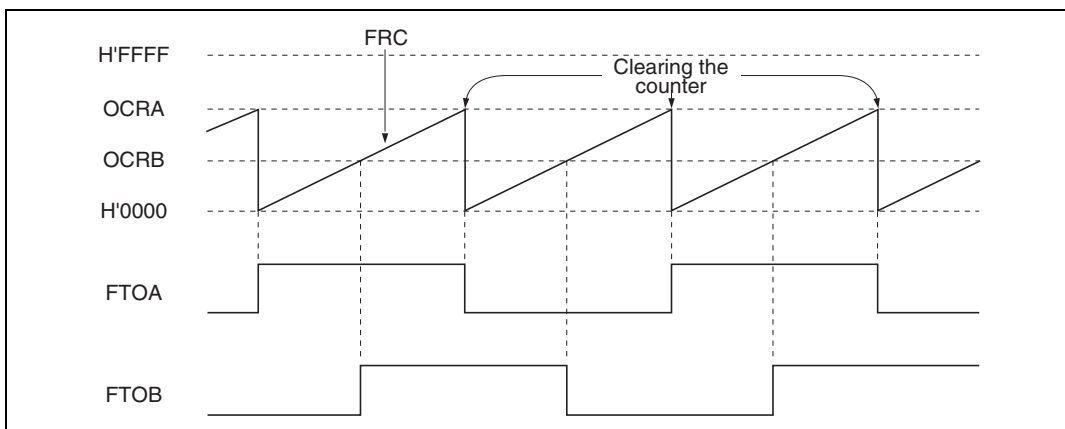
**Table 17.5 Interrupt Causes of the Timer X1**

Abbreviations of the Interrupt Causes	Priority Degree	Contents
ICIA	Interrupt request by the ICFA	
ICIB	Interrupt request by the ICFB	
ICIC	Interrupt request by the ICFC	
ICID	Interrupt request by the ICFD	
OCIA	Interrupt request by the OCFA	
OCIB	Interrupt request by the OCFB	
FOVI	Interrupt request by the OVF	

## 17.6 Exemplary Uses of the Timer X1

Figure 17.12 indicated below shows an example of outputting at optional phase difference of the pulses of the 50% duty. For this setting, follow the procedures listed below.

- (1) Set the CCLRA bit of the TCSRX to "1".
- (2) Each time a comparing match occurs, the OLVLA bit and the OLVLB bit are reversed by use of the software.



**Figure 17.12 An Exemplary Pulse Outputting**

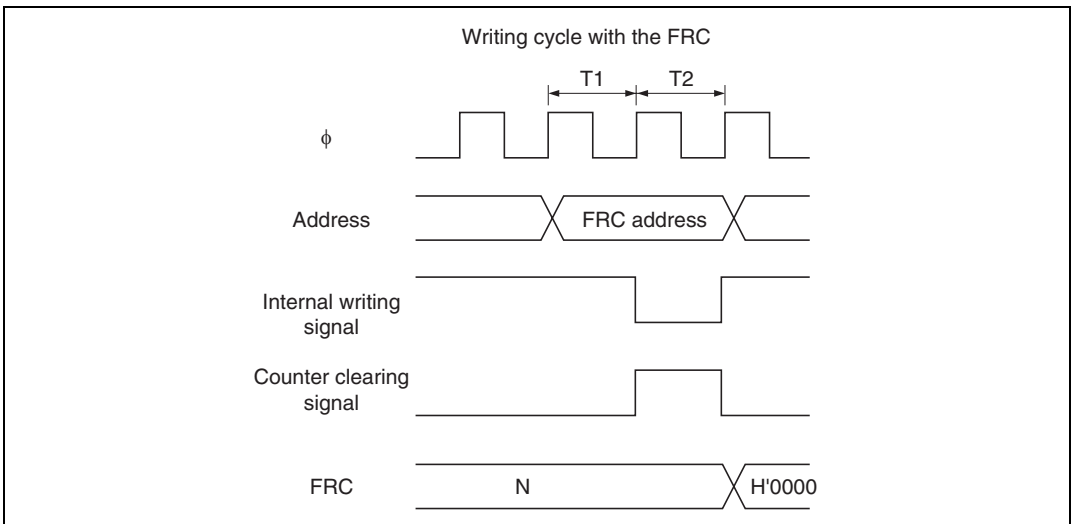
## 17.7 Precautions when Using the Timer X1

Pay great attention to the fact that the following competitions and operations occur during operation of the Timer X1.

### 17.7.1 Competition between Writing and Clearing with the FRC

When a counter clearing signal is issued under the T2 state where the FRC is under the writing cycle, writing into the FRC will not be effected and the priority will be given to clearing of the FRC.

Figure 17.13 shows the timing chart in this case.



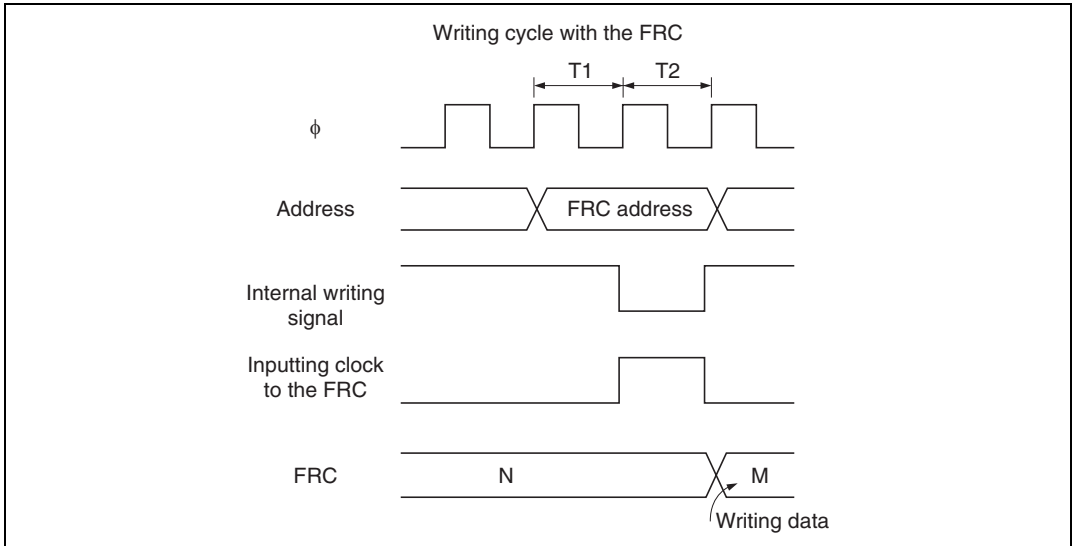
**Figure 17.13 Competition between Writing and Clearing with the FRC**



### 17.7.2 Competition between Writing and Counting Up with the FRC

When a counting up cause occurs under the T2 state where the FRC is under the writing cycle, the counting up will not be effected and the priority will be given to count writing.

Figure 17.14 shows the timing chart in this case.

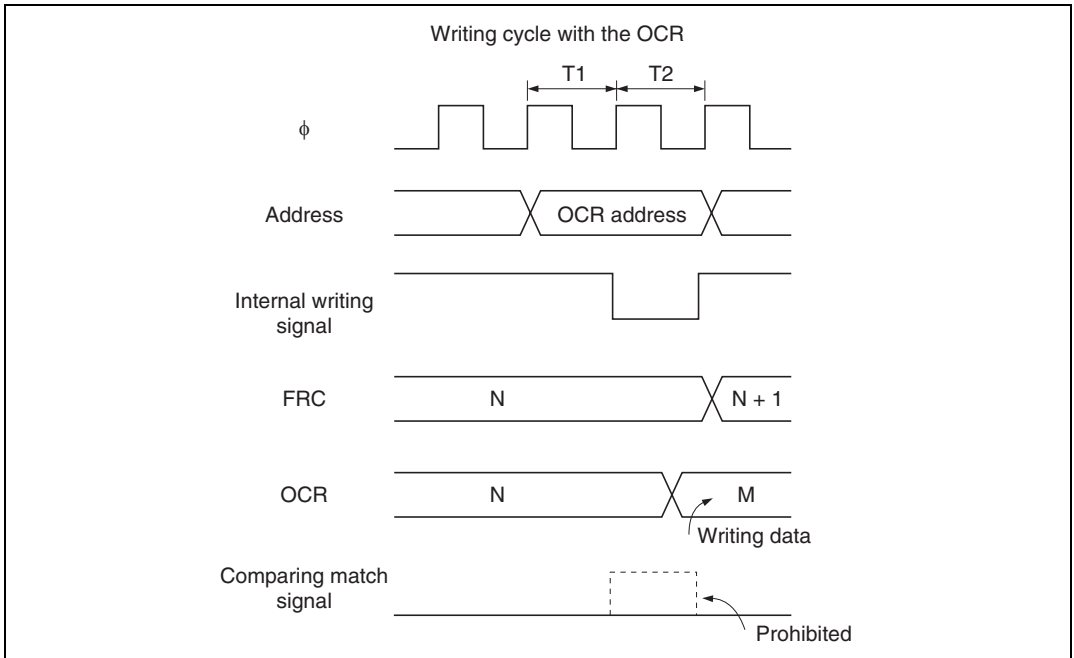


**Figure 17.14 Competition between Writing and Counting Up with the FRC**

### 17.7.3 Competition between Writing and Comparing Match with the OCR

When a comparing match occurs under the T2 state where the OCRA and OCRB are under the writing cycle, the priority will be given to writing of the OCR and the comparing match signal will be prohibited.

Figure 17.15 shows the timing chart in this case.



**Figure 17.15 Competition between Writing and Comparing Match with the OCR**

### 17.7.4 Changing over the Internal Clocks and Counter Operations

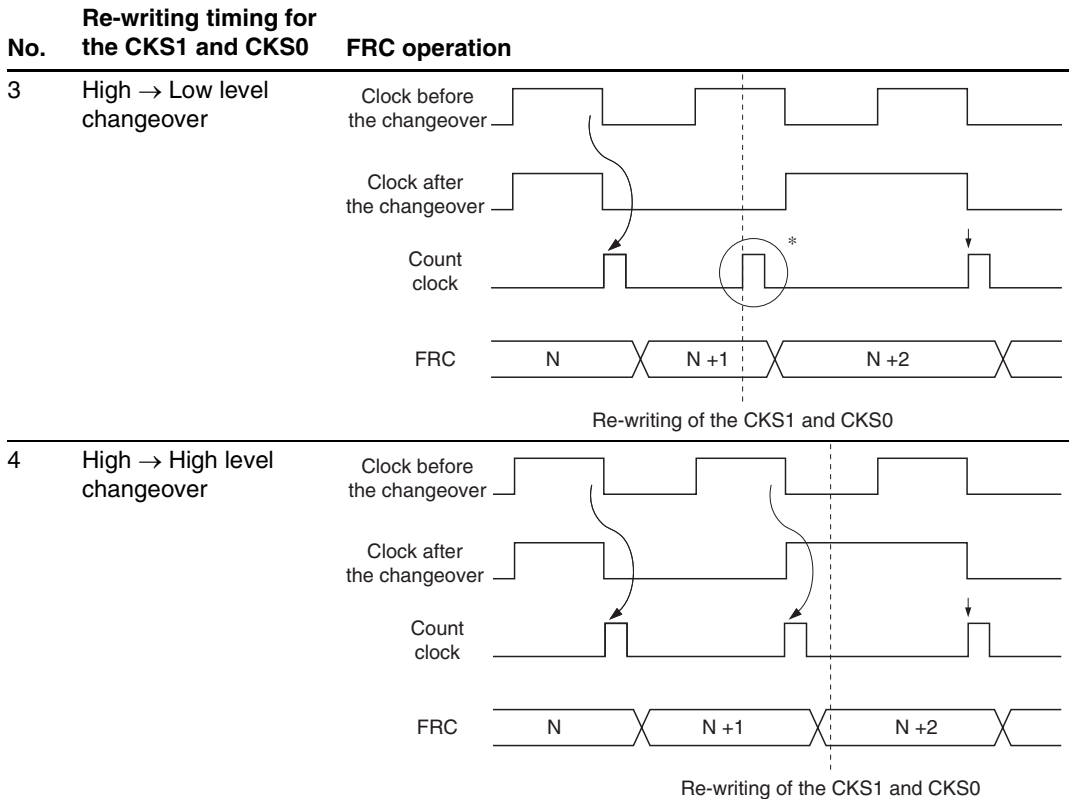
Depending on the timing of changing over the internal clocks, the FRC may count up. Table 17.6 indicated below shows the relations between the timing of changing over the internal clocks (Re-writing of the CKS1 and CKS0) and the FRC operations.

When using an internal clock, the counting clock is being generated detecting the falling edge of the internal clock dividing the system clock ( $\phi$ ). For this reason, like Item No. 3 of table 17.6, count clock signals are issued deeming the timing before the changeover as the falling edge to have the FRC to count up.

Also, when changing over between an internal clock and the external clock, the FRC may count up.

**Table 17.6 Changing over the Internal Clocks and the FRC Operation**

No.	Re-writing Timing for the CKS1 and CKS0	FRC Operation
1	Low $\rightarrow$ Low level changeover	<p data-bbox="579 954 880 975">Re-writing of the CKS1 and CKS0</p>
2	Low $\rightarrow$ High level changeover	<p data-bbox="747 1321 1048 1342">Re-writing of the CKS1 and CKS0</p>



Note: \* The count clock signals are issued deeming the changeover timing as the falling edge to have the FRC to count up.

---

## Section 18 Watchdog Timer (WDT)

### 18.1 Overview

This LSI has an on-chip watchdog timer with one channel (WDT) for monitoring system operation. The WDT outputs an overflow signal if a system crash prevents the CPU from writing to the timer counter, allowing it to overflow. At the same time, the WDT can also generate an internal reset signal or internal NMI interrupt signal.

When this watchdog function is not needed, the WDT can be used as an interval timer. In interval timer mode, an interval timer interrupt is generated each time the counter overflows.

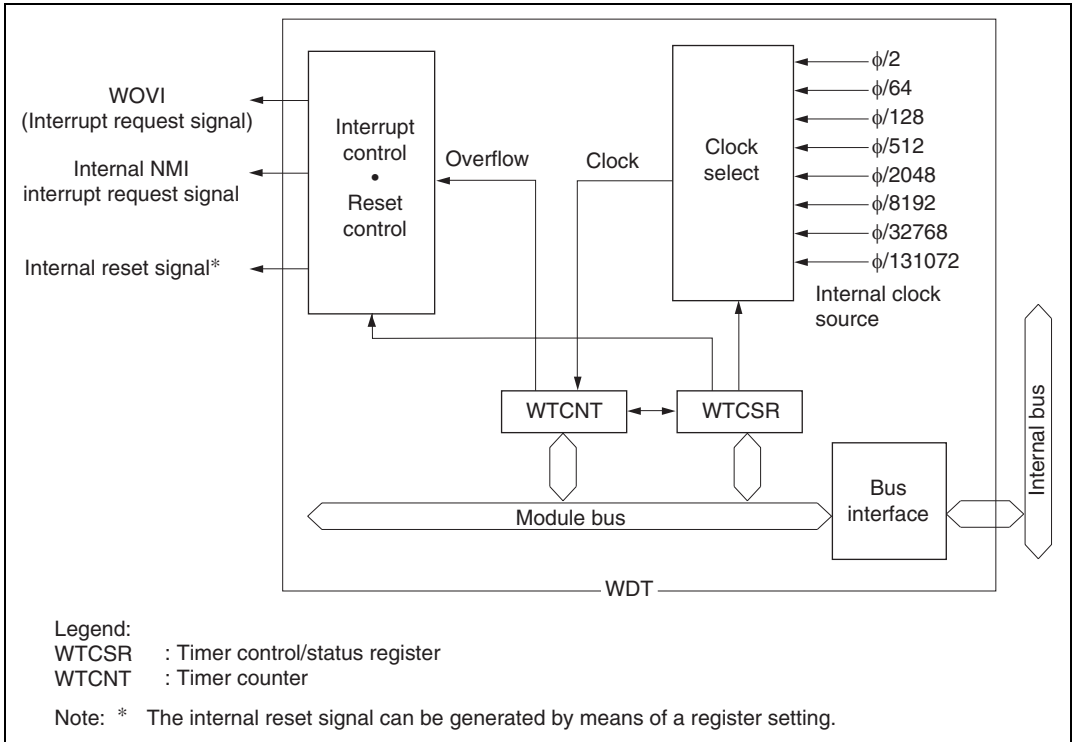
#### 18.1.1 Features

WDT features are listed below.

- Switchable between watchdog timer mode and interval timer mode
  - WOVN interrupt generation in interval timer mode
- Internal reset or internal interrupt generated when the timer counter overflows
  - Choice of internal reset or NMI interrupt generation in watchdog timer mode
- Choice of 8 counter input clocks
  - Maximum WDT interval: system clock period  $\times$  131072  $\times$  256

### 18.1.2 Block Diagram

Figure 18.1 shows block diagram of WDT.



**Figure 18.1 Block Diagram of WDT**

### 18.1.3 Register Configuration

The WDT has two registers, as summarized in table 18.1. These registers control clock selection, WDT mode switching, the reset signal, etc.

**Table 18.1 WDT Registers**

Name	Abbrev.	R/W	Initial Value	Address <sup>*1</sup>	
				Write <sup>*2</sup>	Read
Watchdog timer control/status register	WTCSR	R/(W) <sup>*3</sup>	H'00	H'FFBC	H'FFBC
Watchdog timer counter	WTCNT	R/W	H'00	H'FFBC	H'FFBD
System control register	SYSCR	R/W	H'09	H'FFE8	H'FFE8

- Notes:
1. Lower 16 bits of the address.
  2. For details of write operations, see section 18.2.4, Notes on Register Access.
  3. Only 0 can be written in bit 7, to clear the flag.

## 18.2 Register Descriptions

### 18.2.1 Watchdog Timer Counter (WTCNT)

Bit :	7	6	5	4	3	2	1	0
Initial value :	0	0	0	0	0	0	0	0
R/W :	R/W	R/W	R/W	R/W	R/W	R/W	R/W	R/W

TCNT is an 8-bit readable/writable\* up-counter.

When the TME bit is set to 1 in WTCSR, WTCNT starts counting pulses generated from the internal clock source selected by bits CKS2 to CKS0 in WTCSR. When the count overflows (changes from H'FF to H'00), the OVF flag in WTCSR is set to 1.

WTCNT is initialized to H'00 by a reset, or when the TME bit is cleared to 0.

Note: \* WTCNT is write-protected by a password to prevent accidental overwriting. For details see section 18.2.4, Notes on Register Access.

### 18.2.2 Watchdog Timer Control/Status Register (WTCSR)

Bit :	7	6	5	4	3	2	1	0
	OVF	WT/ $\bar{I}T$	TME	RSTS	RST/ $\bar{N}MI$	CKS2	CKS1	CKS0
Initial value :	0	0	0	0	0	0	0	0
R/W :	R/(W)*	R/W	R/W	R/W	R/W	R/W	R/W	R/W

Note: \* Only 0 can be written to clear the flag.

WTCSR is an 8-bit readable/writable\* register. Its functions include selecting the clock source to be input to WTCNT, and the timer mode.

WTCSR is initialized to H'00 by a reset.

Note: \* WTCSR is write-protected by a password to prevent accidental overwriting. For details see section 18.2.4, Notes on Register Access.



**Bit 7—Overflow Flag (OVF):** A status flag that indicates that WTCNT has overflowed from H'FF to H'00.

**Bit 7**

<b>OVF</b>	<b>Description</b>
0	[Clearing conditions] (Initial value) (1) Write 0 in the TME bit (2) Read WTCSR when OVF = 1, then write 0 in OVF
1	[Setting condition] When WTCNT overflows (changes from H'FF to H'00) When internal reset request generation is selected in watchdog timer mode, OVF is cleared automatically by the internal reset

**Bit 6—Timer Mode Select (WT/IT):** Selects whether the WDT is used as a watchdog timer or interval timer. If used as an interval timer, the WDT generates an interval timer interrupt request (WOVI) when TCNT overflows. If used as a watchdog timer, the WDT generates a reset or NMI interrupt when TCNT overflows.

**Bit 6**

<b>WT/IT</b>	<b>Description</b>
0	Interval timer mode: Sends the CPU an interval timer interrupt request (WOVI) when WTCNT overflows (Initial value)
1	Watchdog timer mode: Sends the CPU a reset or NMI interrupt request when WTCNT overflows

**Bit 5—Timer Enable (TME):** Selects whether WTCNT runs or is halted.

**Bit 5**

<b>TME</b>	<b>Description</b>
0	WTCNT is initialized to H'00 and halted (Initial value)
1	WTCNT counts

**Bit 4—Reset Select (RSTS):** Reserved. This bit should not be set to 1.

**Bit 3—Reset or NMI ( $\overline{\text{RST/NMI}}$ ):** Specifies whether an internal reset or NMI interrupt is requested on WTCNT overflow in watchdog timer mode.

**Bit 3**

$\overline{\text{RST/NMI}}$	Description	
0	An NMI interrupt request is generated	(Initial value)
1	An internal reset request is generated	

**Bits 2 to 0—Clock Select 2 to 0 (CKS2 to CKS0):** These bits select an internal clock source, obtained by dividing the system clock ( $\phi$ ) for input to WTCNT.

**WDT Input Clock Selection**

Bit 2	Bit 1	Bit 0	Description	
CSK2	CSK1	CSK0	Clock	Overflow Period* (when $\phi = 10$ MHz)
0	0	0	$\phi/2$ (Initial value)	51.2 $\mu$ s
		1	$\phi/64$	1.6 ms
	1	0	$\phi/128$	3.3 ms
		1	$\phi/512$	13.1 ms
1	0	0	$\phi/2048$	52.4 ms
		1	$\phi/8192$	209.7 ms
	1	0	$\phi/32768$	838.9 ms
		1	$\phi/131072$	3.36 s

Note: \* The overflow period is the time from when WTCNT starts counting up from H'00 until overflow occurs.

### 18.2.3 System Control Register (SYSCR)

Bit :	7	6	5	4	3	2	1	0
	—	—	INTM1	INTM0	XRST	NMIEG1	NMIEG0	—
Initial value :	0	0	0	0	1	0	0	1
R/W :	—	—	R	R/W	R	R/W	R/W	—

Only bit 3 is described here. For details on functions not related to the watchdog timer, see sections 3.2.2 and 6.2.1, System Control Register (SYSCR), and the descriptions of the relevant modules.

**Bit 3—External Reset (XRST):** Indicates the reset source. When the watchdog timer is used, a reset can be generated by watchdog timer overflow in addition to external reset input. XRST is a read-only bit. It is set to 1 by an external reset, and cleared to 0 by watchdog timer overflow.

#### Bit 3

XRST	Description
0	Reset is generated by watchdog timer overflow
1	Reset is generated by external reset input (Initial value)

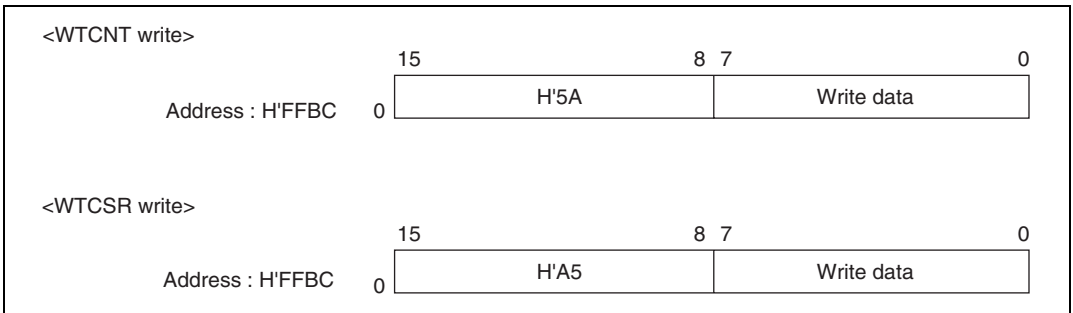
### 18.2.4 Notes on Register Access

The watchdog timer's WTCNT and WTCSR registers differ from other registers in being more difficult to write to. The procedures for writing to and reading these registers are given below.

#### (1) Writing to WTCNT and WTCSR

These registers must be written to by a word transfer instruction. They cannot be written to with byte transfer instructions.

Figure 18.2 shows the format of data written to WTCNT and WTCSR. WTCNT and WTCSR both have the same write address. For a write to WTCNT, the upper byte of the written word must contain H'5A and the lower byte must contain the write data. For a write to WTCSR, the upper byte of the written word must contain H'A5 and the lower byte must contain the write data. This transfers the write data from the lower byte to WTCNT or WTCSR.



**Figure 18.2 Format of Data Written to WTCNT and WTCSR**

(2) Reading WTCNT and WTCSR

These registers are read in the same way as other registers. The read addresses are H'FFBC for WTCSR, and H'FFBD for WTCNT.

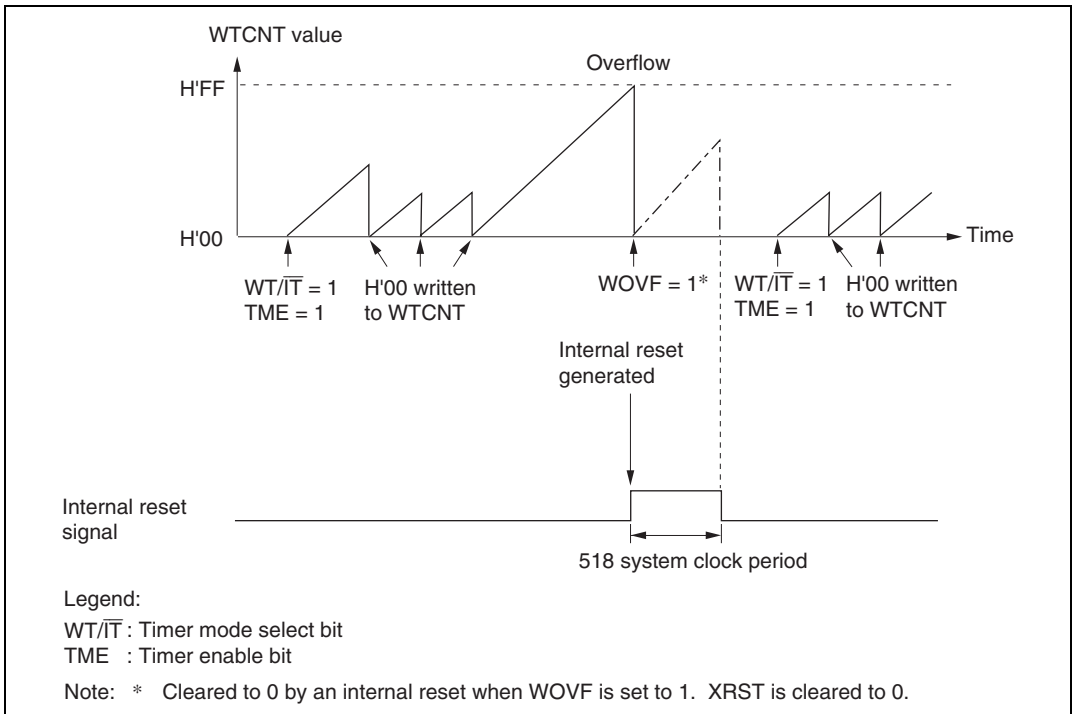
## 18.3 Operation

### 18.3.1 Watchdog Timer Operation

To use the WDT as a watchdog timer, set the  $\overline{WT}/\overline{IT}$  and TME bits in WTCSR to 1. Software must prevent WTCNT overflows by rewriting the WTCNT value (normally by writing H'00) before overflow occurs. This ensures that WTCNT does not overflow while the system is operating normally. If WTCNT overflows without being rewritten because of a system crash or other error, the chip is reset, or an NMI interrupt is generated, for 518 system clock periods (518  $\phi$ ). This is illustrated in figure 18.3.

An internal reset request from the watchdog timer and reset input from the  $\overline{RES}$  pin are handled via the same vector. The reset source can be identified from the value of the XRST bit in SYSCR. If a reset caused by an input signal from the  $\overline{RES}$  pin and a reset caused by WDT overflow occur simultaneously, the  $\overline{RES}$  pin reset has priority, and the XRST bit in SYSCR is set to 1.

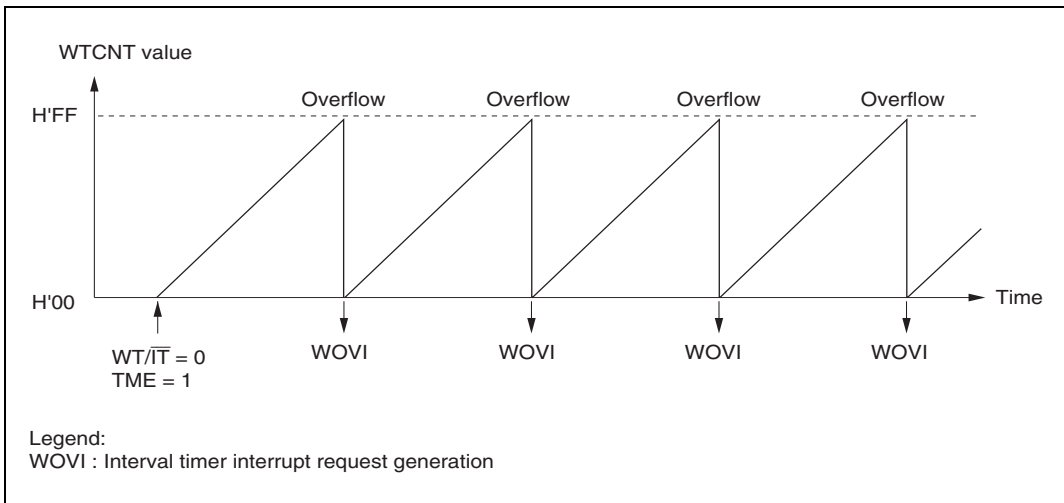
An NMI interrupt request from the watchdog timer and an interrupt request from the NMI pin are handled via the same vector. Simultaneous handling of a watchdog timer NMI interrupt request and an NMI pin interrupt request must therefore be avoided.



**Figure 18.3 Operation in Watchdog Timer Mode**

### 18.3.2 Interval Timer Operation

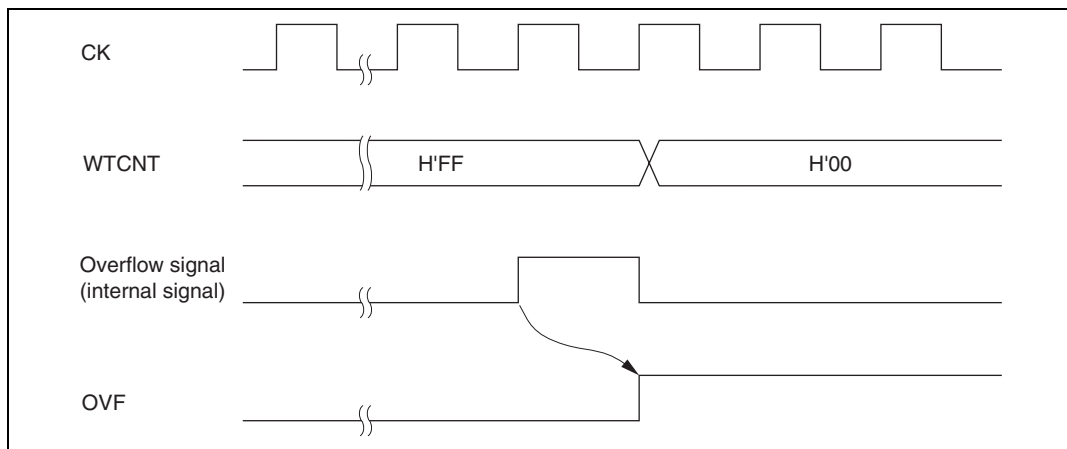
To use the WDT as an interval timer, clear the  $WT/\overline{IT}$  bit in WTCSR to 0 and set the TME bit to 1. An interval timer interrupt (WOVI) is generated each time WTCNT overflows, provided that the WDT is operating as an interval timer, as shown in figure 18.4. This function can be used to generate interrupt requests at regular intervals.



**Figure 18.4 Operation in Interval Timer Mode**

### 18.3.3 Timing of Setting of Overflow Flag (OVF)

The OVF bit in WTCSR is set to 1 if WTCNT overflows during interval timer operation. At the same time, an interval timer interrupt (WOVI) is requested. This timing is shown in figure 18.5. If NMI request generation is selected in watchdog timer mode, when WTCNT overflows the OVF bit in WTCSR is set to 1 and at the same time an NMI interrupt is requested.



**Figure 18.5 Timing of OVF Setting**

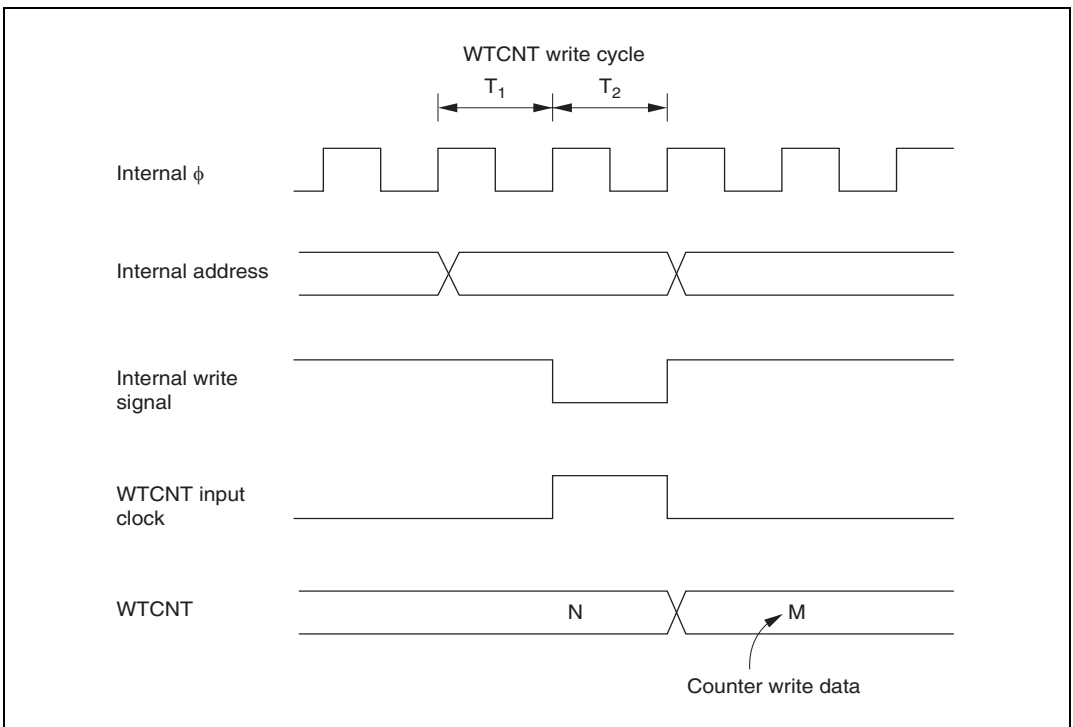
## 18.4 Interrupts

During interval timer mode operation, an overflow generates an interval timer interrupt (WOVI). The interval timer interrupt is requested whenever the OVF flag is set to 1 in WTCSR. OVF must be cleared to 0 in the interrupt handling routine. When NMI interrupt request generation is selected in watchdog timer mode, an overflow generates an NMI interrupt request.

## 18.5 Usage Notes

### 18.5.1 Contention between Watchdog Timer Counter (WTCNT) Write and Increment

If a timer counter clock pulse is generated during the T2 state of a WTCNT write cycle, the write takes priority and the timer counter is not incremented. Figure 18.6 shows this operation.



**Figure 18.6 Contention between WTCNT Write and Increment**



### **18.5.2 Changing Value of CKS2 to CKS0**

If bits CKS2 to CKS0 in WTCSR are written to while the WDT is operating, errors could occur in the incrementation. Software must stop the watchdog timer (by clearing the TME bit to 0) before changing the value of bits CKS2 to CKS0.

### **18.5.3 Switching between Watchdog Timer Mode and Interval Timer Mode**

If the mode is switched from watchdog timer to interval timer, or vice versa, while the WDT is operating, errors could occur in the incrementation. Software must stop the watchdog timer (by clearing the TME bit to 0) before switching the mode.



## Section 19 8-Bit PWM

### 19.1 Overview

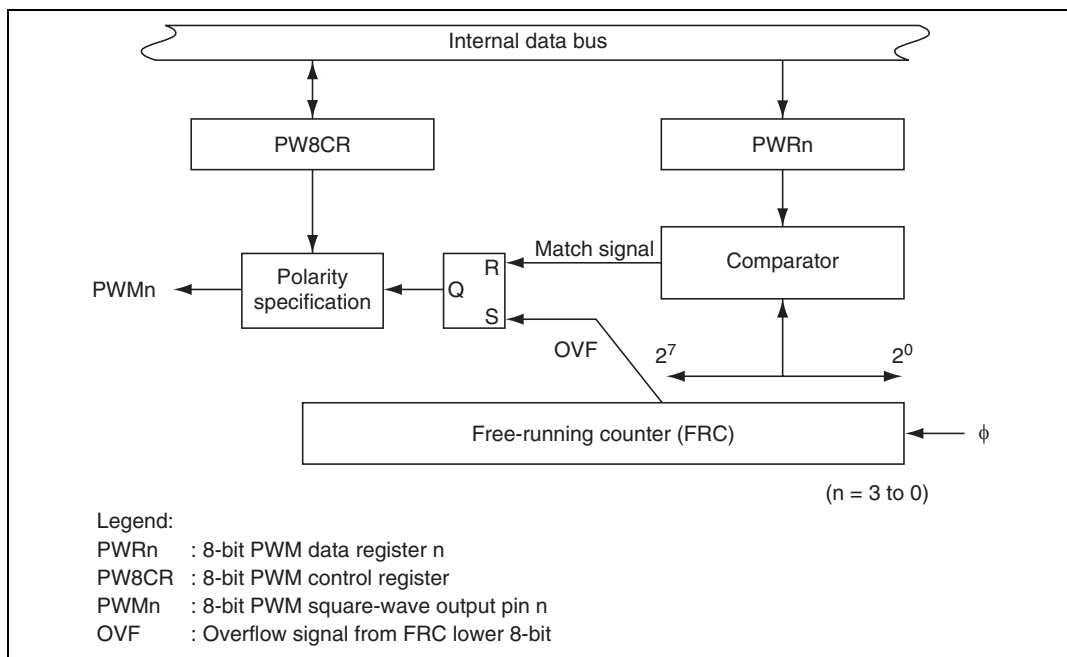
The 8-bit PWM incorporates 4 channels of the duty control method. Its outputs can be used to control a reel motor or loading motor.

#### 19.1.1 Features

- Conversion period: 256-state
- Duty control method

#### 19.1.2 Block Diagram

Figure 19.1 shows a block diagram of the 8-bit PWM (1 channel).



**Figure 19.1 Block Diagram of 8-Bit PWM**

### 19.1.3 Pin Configuration

Table 19.1 shows the 8-bit PWM pin configuration.

**Table 19.1 Pin Configuration**

Name	Abbrev.	I/O	Function
8-bit PWM square-wave output pin 0	PWM0	Output	8-bit PWM square-wave output 0
8-bit PWM square-wave output pin 1	PWM1	Output	8-bit PWM square-wave output 1
8-bit PWM square-wave output pin 2	PWM2	Output	8-bit PWM square-wave output 2
8-bit PWM square-wave output pin 3	PWM3	Output	8-bit PWM square-wave output 3

### 19.1.4 Register Configuration

Table 19.2 shows the 8-bit PWM register configuration.

**Table 19.2 8-Bit PWM Registers**

Name	Abbrev.	R/W	Size	Initial Value	Address*
8-bit PWM data register 0	PWR0	W	Byte	H'00	H'D126
8-bit PWM data register 1	PWR1	W	Byte	H'00	H'D127
8-bit PWM data register 2	PWR2	W	Byte	H'00	H'D128
8-bit PWM data register 3	PWR3	W	Byte	H'00	H'D129
8-bit PWM control register	PW8CR	R/W	Byte	H'F0	H'D12A
Port mode register 3	PMR3	R/W	Byte	H'00	H'FFD0

Note: \* Lower 16 bits of the address.

## 19.2 Register Descriptions

### 19.2.1 Bit PWM Data Registers 0, 1, 2, and 3 (PWR0, PWR1, PWR2, PWR3)

#### PWR0

Bit :	7	6	5	4	3	2	1	0
	PW07	PW06	PW05	PW04	PW03	PW02	PW01	PW00
Initial value :	0	0	0	0	0	0	0	0
R/W :	W	W	W	W	W	W	W	W

#### PWR1

Bit :	7	6	5	4	3	2	1	0
	PW17	PW16	PW15	PW14	PW13	PW12	PW11	PW10
Initial value :	0	0	0	0	0	0	0	0
R/W :	W	W	W	W	W	W	W	W

#### PWR2

Bit :	7	6	5	4	3	2	1	0
	PW27	PW26	PW25	PW24	PW23	PW22	PW21	PW20
Initial value :	0	0	0	0	0	0	0	0
R/W :	W	W	W	W	W	W	W	W

#### PWR3

Bit :	7	6	5	4	3	2	1	0
	PW37	PW36	PW35	PW34	PW33	PW32	PW31	PW30
Initial value :	0	0	0	0	0	0	0	0
R/W :	W	W	W	W	W	W	W	W

8-bit PWM data registers 0, 1, 2, and 3 (PWR0, PWR1, PWR2, PWR3) control the duty cycle at 8-bit PWM pins. The data written in PWR0, PWR1, PWR2, and PWR3 correspond to the high-level width of one PWM output waveform cycle (256 states).

When data is set in PWR0, PWR1, PWR2, and PWR3, the contents of the data are latched in the PWM waveform generators, updating the PWM waveform generation data.

PWR0, PWR1, PWR2, and PWR3 are write-only registers. When read, all bits are always read as 1.

PWR0, PWR1, PWR2, and PWR3 are initialized to H'00 by a reset.

### 19.2.2 8-Bit PWM Control Register (PW8CR)

Bit :	7	6	5	4	3	2	1	0
	—	—	—	—	PWC3	PWC2	PWC1	PWC0
Initial value :	1	1	1	1	0	0	0	0
R/W :	—	—	—	—	R/W	R/W	R/W	R/W

The 8-bit PWM control register (PW8CR) is an 8-bit readable/writable register that controls PWM functions. PW8CR is initialized to H'00 by a reset.

**Bits 7 to 4—Reserved:** They are always read as 1. Writes are disabled.

**Bits 3 to 0—Output Polarity Select (PWC3 to PWC0):** These bits select the output polarity of PWMn pin between positive or negative (reverse).

#### Bit n

PWCn	Description
0	PWMn pin output has positive polarity (Initial value)
1	PWMn pin output has negative polarity

Note: n = 3 to 0

### 19.2.3 Port Mode Register 3 (PMR3)

Bit :	7	6	5	4	3	2	1	0
	PMR37	PMR36	PMR35	PMR34	PMR33	PMR32	PMR31	PMR30
Initial value :	0	0	0	0	0	0	0	0
R/W :	R/W	R/W	R/W	R/W	R/W	R/W	R/W	R/W

The port mode register 3 (PMR3) controls function switching of each pin in the port 3. Switching is specified for each bit.

The PMR3 is a 8-bit readable/writable register and is initialized to H'00 by a reset.

For bits other than 5 to 2, see section 11.5, Port 3.

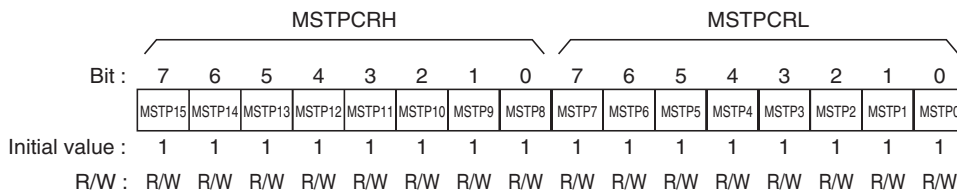
**Bits 5 to 2—P35/PWM3 to P32/PWM0 Pin Switching (PMR35 to PMR32):** These bits set whether the P3n/PWMn pin is used as I/O pin or it is used as 8-bit PWM output PWMm pin.

#### Bit n

PMR3n	Description
0	P3n/PMWm pin functions as P3n I/O pin (Initial value)
1	P3n/PMWm pin functions as PWMm output pin

Note: n = 5 to 2, m = 3 to 0

### 19.2.4 Module Stop Control Register (MSTPCR)



The MSTPCR consists of two 8-bit readable/writable registers that control module stop mode. When MSTP4 bit is set to 1, the 8-bit PWM stops its operation upon completion of the bus cycle and transits to the module stop mode. For details, see section 4.5, Module Stop Mode. The MSTPCR is initialized to H'FFFF by a reset.

**Bit 4: Module Stop (MSTP4):** This bit sets the module stop mode of the 8-bit PWM.

#### MSTPCRL

##### Bit 4

MSTP4	Description
0	8-bit PWM module stop mode is released
1	8-bit PWM module stop mode is set (Initial value)

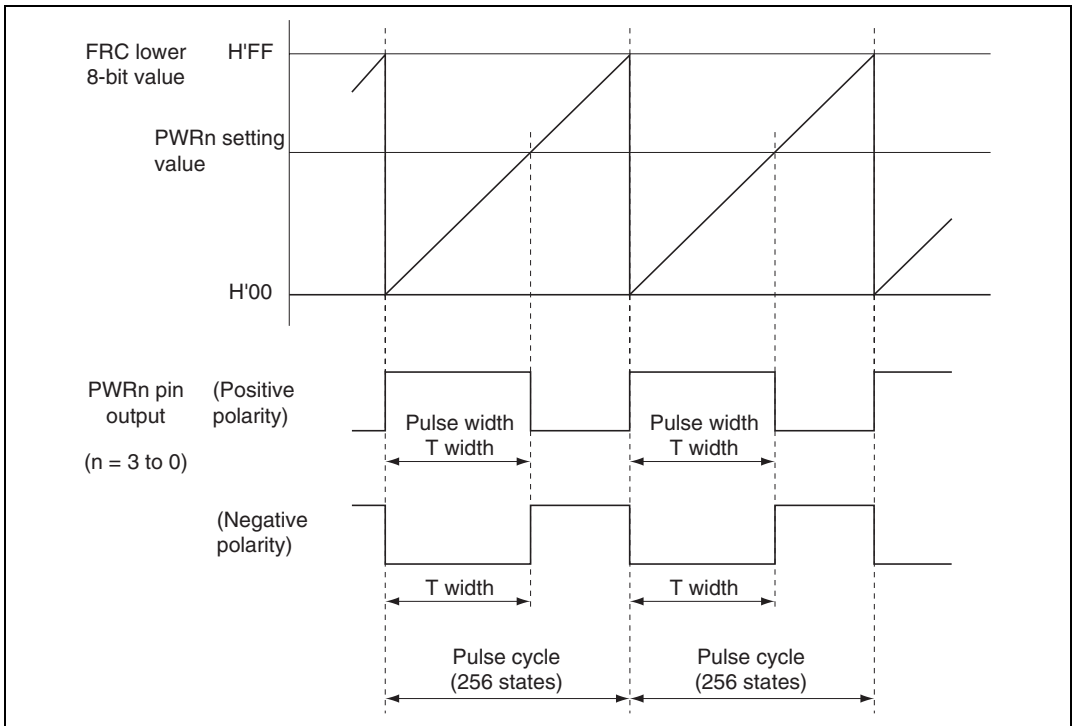
### 19.3 8-Bit PWM Operation

The 8-bit PWM outputs PWM pulses having a cycle length of 256 states and a pulse width determined by the data registers (PWR).

The output PWM pulse can be converted to a DC voltage through integration in a low-pass filter.

Figure 19.2 shows the output waveform example of 8-bit PWM. The pulse width (Twidth) can be obtained by the following expression:

$$\text{Twidth} = (1/\phi) \times (\text{PWR setting value})$$



**Figure 19.2 8-Bit PWM Output Waveform (Example)**



## Section 20 12-Bit PWM

### 20.1 Overview

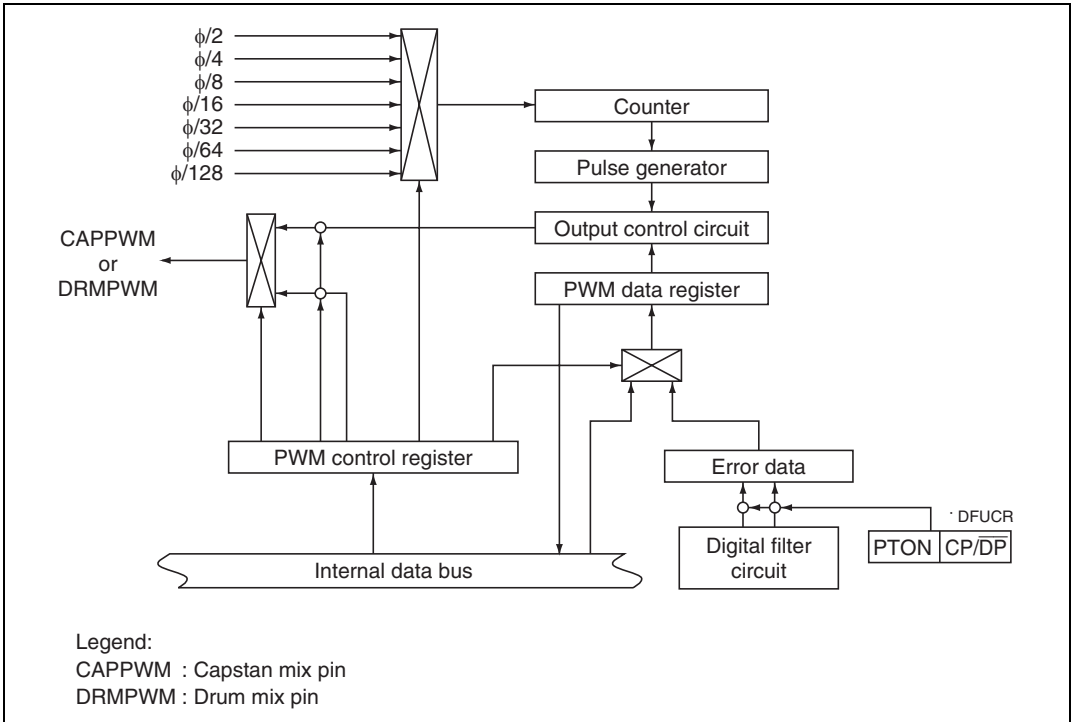
The 12-bit PWM incorporates 2 channels of the pulse pitch control method and functions as the drum and capstan motor controller.

#### 20.1.1 Features

Two on-chip 12-bit PWM signal generators are provided to control motors. These PWMs use the pulse-pitch control method (periodically overriding part of the output). This reduces low-frequency components in the pulse output, enabling a quick response without increasing the clock frequency. The pitch of the PWM signal is modified in response to error data (representing lead or lag in relation to a preset speed and phase).

### 20.1.2 Block Diagram

Figure 20.1 shows a block diagram of the 12-bit PWM (1 channel). The PWM signal is generated by combining quantizing pulses from a 12-bit pulse generator with quantizing pulses derived from the contents of a data register. Low-frequency components are reduced because the two quantizing pulses have different frequencies. The error data is represented by an unsigned 12-bit binary number.



**Figure 20.1 Block Diagram of 12-Bit PWM (1 channel)**

### 20.1.3 Pin Configuration

Table 20.1 shows the 12-bit PWM pin configuration.

**Table 20.1 Pin Configuration**

Name	Abbrev.	I/O	Function
Capstan mix	CAPPWM	Output	12-bit PWM square-wave output
Drum mix	DRMPWM		

### 20.1.4 Register Configuration

Table 20.2 shows the 12-bit PWM register configuration.

**Table 20.2 12-Bit PWM Registers**

Name	Abbrev.	R/W	Size	Initial Value	Address*
12-bit PWM control register	CPWCR	W	Byte	H'42	H'D07B
	DPWCR	W	Byte	H'42	H'D07A
12-bit PWM data register	CPWDR	R/W	Word	H'F000	H'D07C
	DPWDR	R/W	Word	H'F000	H'D078

Note: \* Lower 16 bits of the address.

## 20.2 Register Descriptions

### 20.2.1 12-Bit PWM Control Registers (CPWCR, DPWCR)

#### CPWCR

Bit :	7	6	5	4	3	2	1	0
	CPOL	CDC	CHiZ	CH/L	CSF/DF	CCK2	CCK1	CCK0
Initial value :	0	1	0	0	0	0	1	0
R/W :	W	W	W	W	W	W	W	W

#### DPWCR

Bit :	7	6	5	4	3	2	1	0
	DPOL	DDC	DHiZ	DH/L	DSF/DF	DCK2	DCK1	DCK0
Initial value :	0	1	0	0	0	0	1	0
R/W :	W	W	W	W	W	W	W	W

CPWCR is the PWM output control register for the capstan motor. DPWCR is the PWM output control register for the drum motor. Both are 8-bit writable registers.

CPWCR and DPWCR are initialized to H'42 by a reset, or in sleep mode, standby mode, watch mode, subactive mode, subsleep mode, or module stop mode of the servo circuit.

**Bit 7—Polarity Invert (POL):** This bit can invert the polarity of the modulated PWM signal for noise suppression and other purposes. This bit is invalid when fixed output is selected (when bit DC is set to 1).

#### Bit 7

POL	Description
0	Output with positive polarity (Initial value)
1	Output with inverted polarity

**Bit 6—Output Select (DC):** Selects either PWM modulated output, or fixed output controlled by the pin output bits (Bits 5 and 4).

**Bits 5 and 4—PWM Pin Output (Hi-Z, H/L):** When bit DC is set to 1, the 12-bit PWM output pins (CAPPWM, DRMPWM) output a value determined by the Hi-Z and H/L bits. The output is not affected by bit POL.

In power-down modes, the 12-bit PWM circuit and pin statuses are retained. Before making a transition to a power-down mode, first set bits 6 (DC), 5 (Hi-Z), and 4 (H/L) of the 12-bit PWM control registers (CPWCR and DPWCR) to select a fixed output level. Choose one of the following settings:

Bit 6	Bit 5	Bit 4	Output state
DC	Hi-Z	H/L	
1	0	0	Low output (Initial value)
		1	High output
	1	*	High-impedance
0	*	*	Modulation signal output

Legend: \* Don't care

**Bit 3—Output Data Select (SF/DF):** Selects whether the data to be converted to PWM output is taken from the data register or from the digital filter circuit.

Bit	Description
SF/DF	
0	Modulation by error data from the digital filter circuit (Initial value)
1	Modulation by error data written in the data register

Note: When PWMs output data from the digital filter circuit, the data consisting of the speed and phase filtering results are modulated by PWMs and output from the CAPPWM and DRMPWM pins. However, it is possible to output only drum phase filter results from CAPPWM pin and only capstan phase filter result from DRMPWM pin, by DFUCR settings of the digital filter circuit. See the section 28.11 Digital Filters.

**Bits 2 to 0—Carrier Frequency Select (CK2 to CK0):** Selects the carrier frequency of the PWM modulated signal. Do not set them to 111.

Bit 2	Bit 1	Bit 0	Description	
CK2	CK1	CK0		
0	0	0	$\phi 2$	
		1	$\phi 4$	
	1	0	$\phi 8$	(Initial value)
		1	$\phi 16$	
1	0	0	$\phi 32$	
		1	$\phi 64$	
	1	0	$\phi 128$	
		1	(Do not set)	

## 20.2.2 12-Bit PWM Data Registers (CPWDR, DPWDR)

### CPWDR

Bit :	15	14	13	12	11	10	9	8	7	6	5	4	3	2	1	0
	—	—	—	—	CPWDR11	CPWDR10	CPWDR9	CPWDR8	CPWDR7	CPWDR6	CPWDR5	CPWDR4	CPWDR3	CPWDR2	CPWDR1	CPWDR0
Initial value :	1	1	1	1	0	0	0	0	0	0	0	0	0	0	0	0
R/W :	—	—	—	—	R/W	R/W	R/W	R/W	R/W	R/W	R/W	R/W	R/W	R/W	R/W	R/W

### DPWDR

Bit :	15	14	13	12	11	10	9	8	7	6	5	4	3	2	1	0
	—	—	—	—	DPWDR11	DPWDR10	DPWDR9	DPWDR8	DPWDR7	DPWDR6	DPWDR5	DPWDR4	DPWDR3	DPWDR2	DPWDR1	DPWDR0
Initial value :	1	1	1	1	0	0	0	0	0	0	0	0	0	0	0	0
R/W :	—	—	—	—	R/W	R/W	R/W	R/W	R/W	R/W	R/W	R/W	R/W	R/W	R/W	R/W

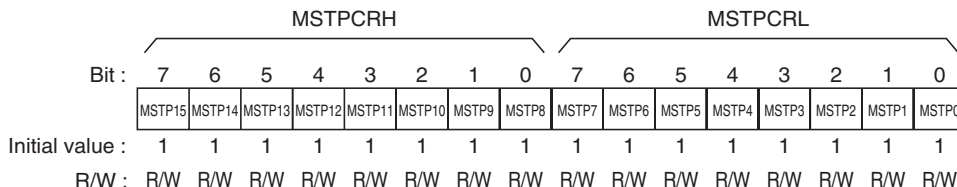
The 12-bit PWM data registers (CPWDR and DPWDR) are 12-bit readable/writable registers in which the data to be converted to PWM output is written.

The data in these registers is converted to PWM output only when bit SF/DF of the corresponding control register is set to 1. The error data from the digital filter circuit is written in the data register, and then modulated by PWM. At this time, the error data from the digital filter circuit can be monitored by reading the data register.

These registers can be accessed by word only, and cannot be accessed by byte. Byte access gives unassured results.

CPWDR and DPWDR are initialized to H'F000 by a reset, or in sleep mode, standby mode, watch mode, subactive mode, subsleep mode, or module stop mode of the servo circuit.

### 20.2.3 Module Stop Control Register (MSTPCR)



The MSTPCR consists of two 8-bit readable/writable registers that control module stop mode. When the MSTP1 bit is set to 1, the 12-bit PWM and Servo circuit, stops their operation upon completion of the bus cycle and transits to the module stop mode. For details, see section 4.5, Module Stop Mode.

The MSTPCR is initialized to H'FFFF by a reset.

**Bit 1—Module Stop (MSTP1):** This bit sets the module stop mode of the 12-bit PWM. This bit also controls the module stop mode of the servo circuit.

#### MSTPCRL

##### Bit 1

MSTP1	Description
0	Module stop mode of the 12-bit PWM and servo circuit is released
1	Module stop mode of the 12-bit PWM and servo circuit is set <span style="float: right;">(Initial value)</span>

## 20.3 Operation

### 20.3.1 Output Waveform

The PWM signal generator combines the error data with the output from an internal pulse generator to produce a pulse-width modulated signal.

When  $V_{cc}/2$  is set as the reference value, the following conditions apply:

- When the motor is running at the correct speed and phase, the PWM signal is output with a 50% duty cycle.
- When the motor is running behind the correct speed or phase, it is corrected by periodically holding part of the PWM signal low. The part held low depends on the size of the error.
- When the motor is running ahead of the correct speed or phase, it is corrected by periodically holding part of the PWM signal high. The part held high depends on the size of the error.

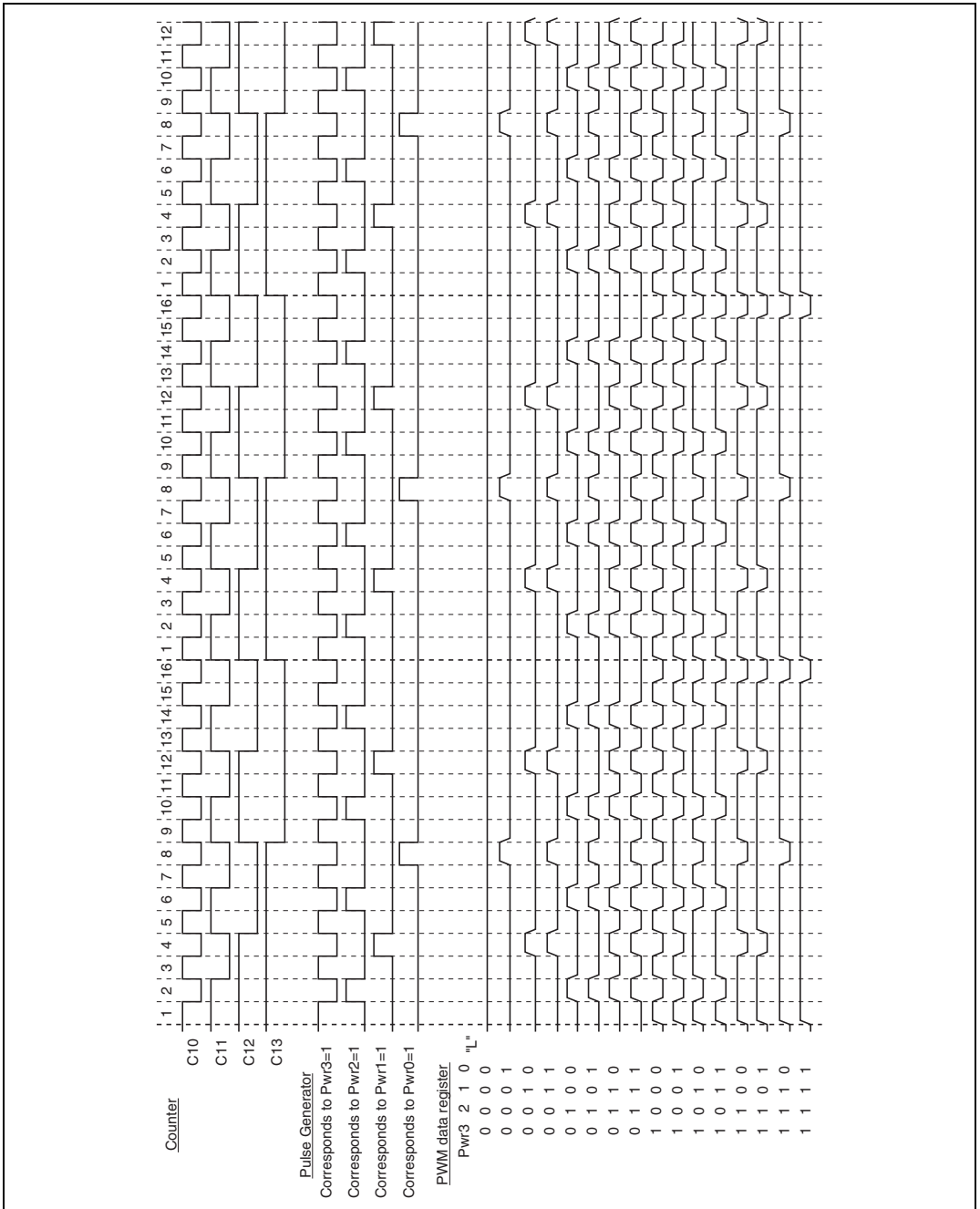
When the motor is running at the correct speed and phase, the error data is a 12-bit value representing  $1/2$  (1000 0000 0000), and the PWM output has the same frequency as the selected division clock.

After the error data has been converted into a PWM signal, the PWM signal can be smoothed into a DC voltage by an external low-pass filter (LPF). The smoothed error data can be used to control the motor.

Figure 20.2 shows sample waveform outputs.

The 12-bit PWM pin outputs a low-level signal upon reset, in power-down mode or at module-stop.





**Figure 20.2 Sample Waveform Output by 12-Bit PWM (4 Bits)**



## Section 21 14-Bit PWM

### 21.1 Overview

The 14-bit PWM is a pulse division type PWM which can be used for V-synthesizer, etc.

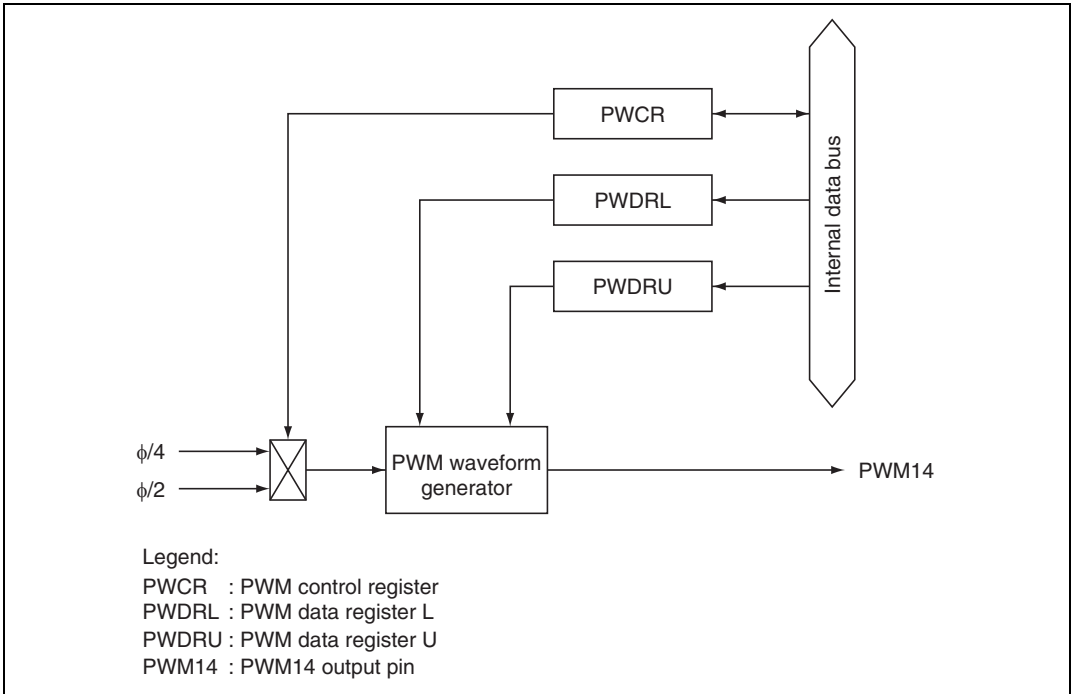
#### 21.1.1 Features

Features of the 14-bit PWM are given below:

- Choice of two conversion periods  
A conversion period of  $32768/\phi$  with a minimum modulation width of  $2/\phi$ , or a conversion period of  $16384/\phi$  with a minimum modulation width of  $1/\phi$ , can be selected.
- Pulse division method for less ripple

### 21.1.2 Block Diagram

Figure 21.1 shows a block diagram of the 14-bit PWM.



**Figure 21.1 Block Diagram of 14-Bit PWM**

### 21.1.3 Pin Configuration

Table 21.1 shows the 14-bit PWM pin configuration.

**Table 21.1 Pin Configuration**

Name	Abbrev.	I/O	Function
PWM 14-bit square-wave output pin	PWM14*	Output	14-bit PWM square-wave output

Note: \* This pin also functions as P40 general I/O pin. When using this pin, set the pin function by the port mode register 4 (PMR4). For details, see section 11.6, Port 4.

### 21.1.4 Register Configuration

Table 21.2 shows the 14-bit PWM register configuration.

**Table 21.2 14-Bit PWM Registers**

<b>Name</b>	<b>Abbrev.</b>	<b>R/W</b>	<b>Size</b>	<b>Initial Value</b>	<b>Address*</b>
PWM control register	PWCR	R/W	Byte	H'FE	H'D122
PWM data register U	PWDRU	W	Byte	H'00	H'D121
PWM data register L	PWDRL	W	Byte	H'00	H'D120

Note: \* Lower 16 bits of the address.

## 21.2 Register Descriptions

### 21.2.1 PWM Control Register (PWCR)

Bit :	7	6	5	4	3	2	1	0
	—	—	—	—	—	—	—	PWCR0
Initial value :	1	1	1	1	1	1	1	0
R/W :	—	—	—	—	—	—	—	R/W

The PWM control register (PWCR) is an 8-bit read/write register that controls the 14-bit PWM functions. PWCR is initialized to H'FE by a reset.

**Bits 7 to 1—Reserved:** They are always read as 1. Writes are disabled.

**Bit 0—Clock Select (PWCR0):** Selects the clock supplied to the 14-bit PWM.

#### Bit 0

PWCR0	Description
0	The input clock is $\phi/2$ ( $t_\phi = 2/\phi$ ) (Initial value) The conversion period is $16384/\phi$ , with a minimum modulation width of $1/\phi$
1	The input clock is $\phi/4$ ( $t_\phi = 4/\phi$ ) The conversion period is $32768/\phi$ , with a minimum modulation width of $2/\phi$

Note:  $t_\phi$ : Period of PWM clock input

## 21.2.2 PWM Data Registers U and L (PWDRU, PWDRL)

### PWDRU

Bit :	7	6	5	4	3	2	1	0
	—	—	PWDRU5	PWDRU4	PWDRU3	PWDRU2	PWDRU1	PWDRU0
Initial value :	1	1	0	0	0	0	0	0
R/W :	—	—	W	W	W	W	W	W

### PWDRL

Bit :	7	6	5	4	3	2	1	0
	PWDRL7	PWDRL6	PWDRL5	PWDRL4	PWDRL3	PWDRL2	PWDRL1	PWDRL0
Initial value :	0	0	0	0	0	0	0	0
R/W :	W	W	W	W	W	W	W	W

PWM data registers U and L (PWDRU and PWDRL) indicate high level width in one PWN waveform cycle.

PWDRU and PWDRL form a 14-bit write-only register, with the upper 6 bits assigned to PWDRU and the lower 8 bits to PWDRL. The value written in PWDRU and PWDRL gives the total high-level width of one PWM waveform cycle. Both PWDRU and PWDRL are accessible by byte access only. Word access gives unassured results.

When 14-bit data is written in PWDRU and PWDRL, the contents are latched in the PWM waveform generator and the PWM waveform generation data is updated. When writing the 14-bit data, follow these steps:

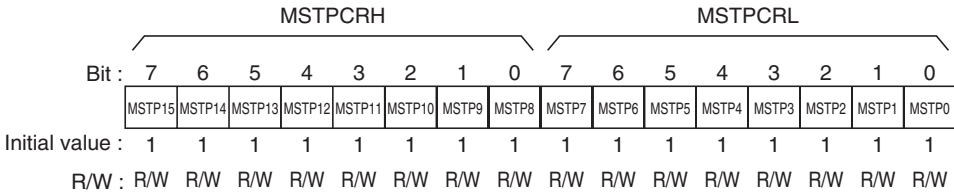
- (1) Write the lower 8 bits to PWDRL.
- (2) Write the upper 6 bits to PWDRU.

Write the data first to PWDRL and then to PWDRU.

PWDRU and PWDRL are write-only registers. When read, all bits always read 1.

PWDRU and PWDRL are initialized to H'C000 by a reset.

### 21.2.3 Module Stop Control Register (MSTPCR)



The module stop control register (MSTPCR) consists of two 8-bit readable/writable registers that control the module stop mode functions.

When the MSTP5 bit is set to 1, the 14-bit PWM operation stops at the end of the bus cycle and a transition is made to module stop mode. For details, see section 4.5, Module Stop Mode.

MSTPCR is initialized to H'FFFF by a reset.

**Bit 5—Module Stop (MSTP5):** Specifies the module stop mode of the 14-bit PWM.

#### MSTPCRL

##### Bit 5

MSTP5	Description
0	14-bit PWM module stop mode is released
1	14-bit PWM module stop mode is set <span style="float: right;">(Initial value)</span>



## 21.3 14-Bit PWM Operation

When using the 14-bit PWM, set the registers in this sequence:

- (1) Set bit PMR40 to 1 in port mode register 4 (PMR4) so that pin P40/PWM14 is designated for PWM output.
- (2) Set bit PWCR0 in the PWM control register (PWCR) to select a conversion period of either  $32768/\phi$  (PWCR0 = 1) or  $16384/\phi$  (PWCR0 = 0).
- (3) Set the output waveform data in PWM data registers U and L (PWDRU, PWDRL). Be sure to write byte data first to PWDRL and then to PWDRU. When the data is written in PWDRU, the contents of these registers are latched in the PWM waveform generator, and the PWM waveform generation data is updated in synchronization with internal signals.

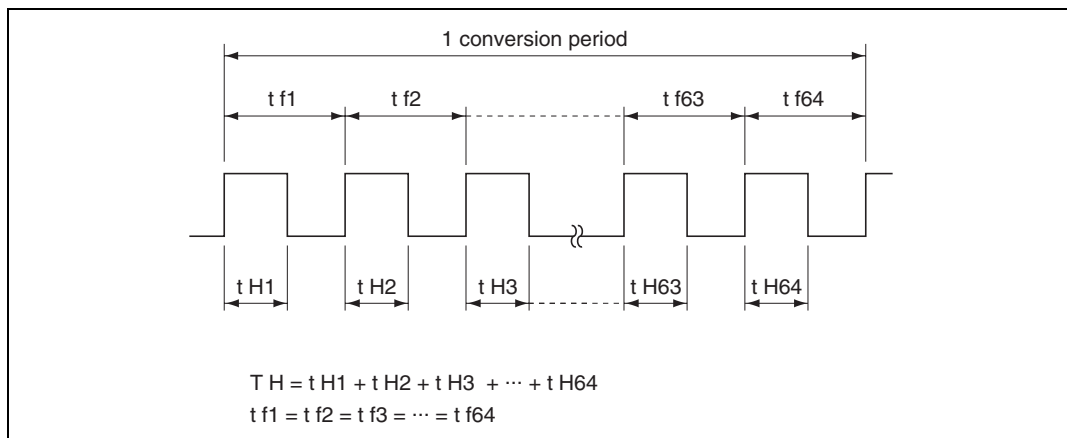
One conversion period consists of 64 pulses, as shown in figure 21.2. The total high-level width during this period ( $T_H$ ) corresponds to the data in PWDRU and PWDRL. This relation can be expressed as follows:

$$T_H = (\text{data value in PWDRU and PWDRL} + 64) \times t\phi/2$$

where  $t\phi$  is the period of PWM clock input:  $2/\phi$  (bit PWCR0 = 0) or  $4/\phi$  (bit PWCR0 = 1).

If the data value in PWDRU and PWDRL is from H'3FC0 to H'3FFF, the PWM output stays high. When the data value is H'0000,  $T_H$  is calculated as follows:

$$T_H = 64 \times t\phi/2 = 32 \cdot t\phi$$



**Figure 21.2 Waveform Output by 14-Bit PWM**



---

## Section 22 Prescaler Unit

### 22.1 Overview

The prescaler unit (PSU) has a 18-bit free running counter (FRC) that uses  $\phi$  as a clock source and a 5-bit counter that uses  $\phi W$  as a clock source.

#### 22.1.1 Features

- Prescaler S (PSS):  
Generates frequency division clocks that are input to peripheral functions.
- Prescaler W (PSW):  
When a timer A is used as a clock time base, the PSW frequency-divides subclocks and generates input clocks.
- Stable oscillation wait time count:  
During the return from the low power consumption mode excluding the sleep mode, the FRC counts the stable oscillation wait time.
- 8-bit PWM  
The lower 8 bits of the FRC is used as 8-bit PWM cycle and duty cycle generation counters. (Conversion cycle: 256 states)
- 8-bit input capture by  $\overline{IC}$  pins  
Catches the 8 bits of  $2^{15}$  to  $2^8$  of the FRC according to the edge of the  $\overline{IC}$  pin for remote control receiving.
- Frequency division clock output:  
Can output the frequency division clock for the system clock or the frequency division clock for the subclock from the frequency division clock output pin (TMOW).

### 22.1.2 Block Diagram

Figure 22.1 shows a block diagram of the prescaler unit.

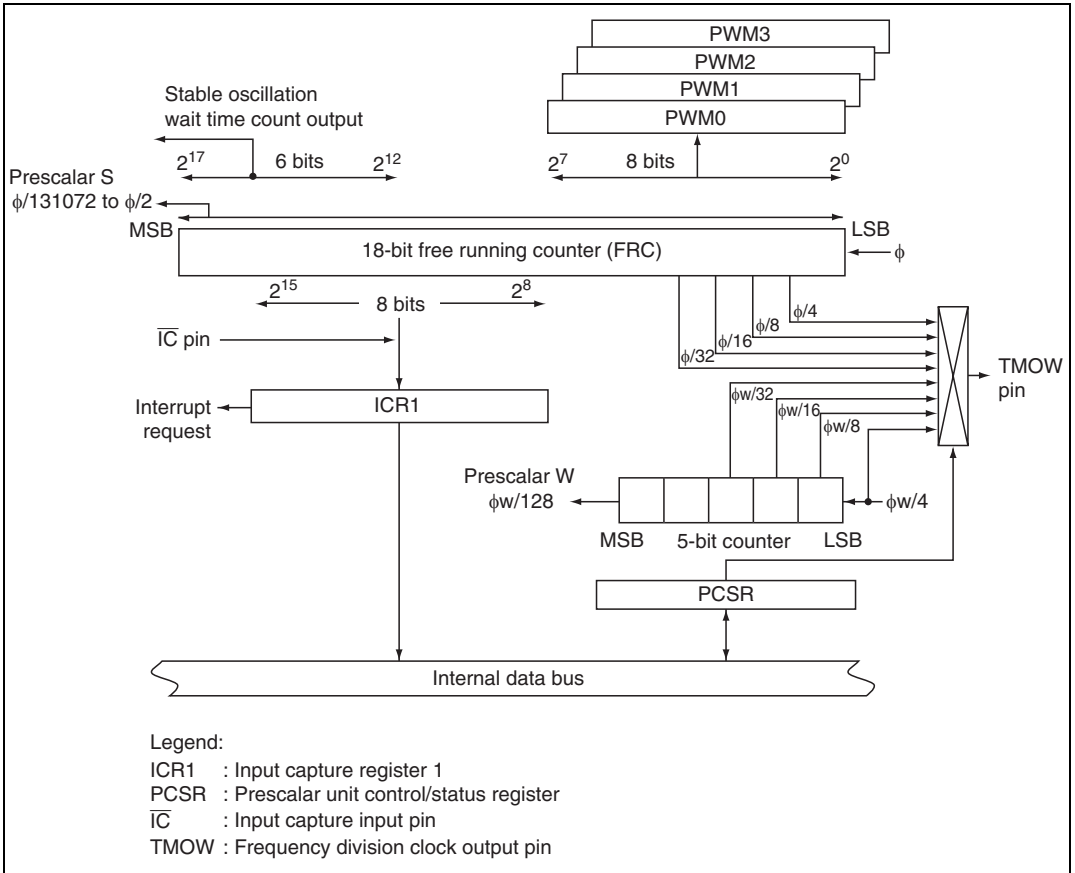


Figure 22.1 Block Diagram of Prescaler Unit

### 22.1.3 Pin Configuration

Table 22.1 shows the pin configuration of the prescaler unit.

**Table 22.1 Pin Configuration**

Name	Abbrev.	I/O	Function
Input capture input	$\overline{IC}$	Input	Prescaler unit input capture input pin
Frequency division clock output	TMOW	Output	Prescaler unit frequency division clock output pin

### 22.1.4 Register Configuration

Table 22.2 shows the register configuration of the prescaler unit.

**Table 22.2 Register Configuration**

Name	Abbrev.	R/W	Size	Initial Value	Address*
Input capture register 1	ICR1	R	Byte	H'00	H'D12C
Prescaler unit control/status register	PCSR	R/W	Byte	H'08	H'D12D

Note: \* Lower 16 bits of the address.

## 22.2 Registers

### 22.2.1 Input Capture Register 1 (ICR1)

Bit :	7	6	5	4	3	2	1	0
	ICR17	ICR16	ICR15	ICR14	ICR13	ICR12	ICR11	ICR10
Initial value :	0	0	0	0	0	0	0	0
R/W :	R	R	R	R	R	R	R	R

Input capture register 1 (ICR1) captures 8-bit data of  $2^{15}$  to  $2^8$  of the FRC according to the edge of the  $\overline{IC}$  pin.

ICR1 is an 8-bit read-only register. The write operation becomes invalid. The ICR1 values are undefined until the first capture is generated after the mode has been set to the standby mode, watch mode, subactive mode, and subsleeve mode. When reset, ICR1 is initialized to H'00.

### 22.2.2 Prescaler Unit Control/Status Register (PCSR)

Bit :	7	6	5	4	3	2	1	0
	ICIF	ICIE	ICEG	NCon/off	—	DCS2	DCS1	DCS0
Initial value :	0	0	0	0	1	0	0	0
R/W :	R/(W)*	R/W	R/W	R/W	—	R/W	R/W	R/W

Note: \* Only 0 can be written to clear the flag.

The prescaler unit control/status register (PCSR) controls the input capture function and selects the frequency division clock that is output from the TMOW pin.

PCSR is an 8-bit read/write enable register. When reset, PCSR is initialized to H'08.

**Bit 7—Input Capture Interrupt Flag (ICIF):** Input capture interrupt request flag. This indicates that the input capture was performed according to the edge of the  $\overline{IC}$  pin.

#### Bit 7

ICIF	Description
0	[Clear condition] (Initial value) When 0 is written after 1 has been read
1	[Set condition] When the input capture was performed according to the edge of the $\overline{IC}$ pin

**Bit 6—Input Capture Interrupt Enable (ICIE):** When ICIF was set to 1 by the input capture according to the edge of the  $\overline{IC}$  pin, ICIE enables and disables the generation of an input capture interrupt.

**Bit 6**

ICIE	Description
0	Disables the generation of an input capture interrupt (Initial value)
1	Enables the generation of an input capture interrupt

**Bit 5— $\overline{IC}$  Pin Edge Select (ICEG):** ICEG selects the input edge sense of the  $\overline{IC}$  pin.

**Bit 5**

ICEG	Description
0	Detects the falling edge of the $\overline{IC}$ pin input (Initial value)
1	Detects the rising edge of the $\overline{IC}$ pin input

**Bit 4—Noise Cancel ON/OFF (NCon/off):** NCon/off selects enable/disable of the noise cancel function of the  $\overline{IC}$  pin. For the noise cancel function, see section 22.3, Noise Cancel Circuit.

**Bit 4**

NCon/off	Description
0	Disables the noise cancel function of the $\overline{IC}$ pin (Initial value)
1	Enables the noise cancel function of the $\overline{IC}$ pin

**Bit 3—Reserved:** When the bit is read, 1 is always read. The write operation is invalid.

**Bits 2 to 0—Frequency Division Clock Output Select (DCS2 to DCS0):** DCS2 to DCS0 select eight types of frequency division clocks that are output from the TMOW pin.

Bit 2	Bit 1	Bit 0	Description
DCS2	DCS1	DCS0	
0	0	0	Outputs PSS, $\phi/32$ (Initial value)
		1	Outputs PSS, $\phi/16$
	1	0	Outputs PSS, $\phi/8$
		1	Outputs PSS, $\phi/4$
1	0	0	Outputs PSW, $\phi W/32$
		1	Outputs PSW, $\phi W/16$
	1	0	Outputs PSW, $\phi W/8$
		1	Outputs PSW, $\phi W/4$

### 22.2.3 Port Mode Register 1 (PMR1)

Bit :	7	6	5	4	3	2	1	0
	PMR17	PMR16	PMR15	PMR14	PMR13	PMR12	PMR11	PMR10
Initial value :	0	0	0	0	0	0	0	0
R/W :	R/W	R/W	R/W	R/W	R/W	R/W	R/W	R/W

The port mode register 1 (PMR1) controls switching of each pin function of port 1. The switching is specified in a unit of bit.

PMR1 is an 8-bit read/write enable register. When reset, PMR1 is initialized to H'00.

**Bit 7—P17/TMOW Pin Switching (PMR17):** PMR17 sets whether the P17/TMOW pin is used as a P17 I/O pin or a TMOW pin for division clock output.

#### Bit 7

PMR17	Description
0	The P17/TMOW pin functions as a P17 I/O pin (Initial value)
1	The P17/TMOW pin functions as a TMOW pin for division clock output



**Bit 6—P16/ $\overline{\text{IC}}$  Pin Switching (PMR16):** PMR16 sets whether the P16/ $\overline{\text{IC}}$  pin is used as a P16 I/O pin or an  $\overline{\text{IC}}$  pin for the input capture input of the prescaler unit.

**Bit 6**

PMR16	Description
0	The P16/ $\overline{\text{IC}}$ pin functions as a P16 I/O pin (Initial value)
1	The P16/ $\overline{\text{IC}}$ pin functions as an $\overline{\text{IC}}$ input function

## 22.3 Noise Cancel Circuit

The  $\overline{\text{IC}}$  pin has a built-in a noise cancel circuit. The circuit can be used for noise protection such as remote control receiving. The noise cancel circuit samples the input values of the  $\overline{\text{IC}}$  pin twice at an interval of 256 states. If the input values are different, they are assumed to be noise.

The  $\overline{\text{IC}}$  pin can specify enable/disable of the noise cancel function according to the bit 4 (NCon/off) of the prescaler unit control/status register (PCSR).

## 22.4 Operation

### 22.4.1 Prescaler S (PSS)

The PSS is a 17-bit counter that uses the system clock ( $\phi = \text{fosc}$ ) as an input clock and generates the frequency division clocks ( $\phi/131072$  to  $\phi/2$ ) of the peripheral function. The low-order 17 bits of the 18-bit free running counter (FRC) correspond to the PSS. The FRC is incremented by one clock. The PSS output is shared by the timer and serial communication interface (SCI), and the frequency division ratio can independently be set by each built-in peripheral function.

When reset, the FRC is initialized to H'00000, and starts increment after reset has been released. Because the system clock oscillator is stopped in standby mode, watch mode, subactive mode, and subsleep mode, the PSS operation is also stopped. In this case, the FRC is also initialized to H'00000.

The FRC cannot be read and written from the CPU.

### 22.4.2 Prescaler W (PSW)

PSW is a counter that uses the subclock as an input clock. The PSW also generates the input clock of the timer A. In this case, the timer A functions as a clock time base.

When reset, the PSW is initialized to H'00, and starts increment after reset has been released. Even if the mode has been shifted to the standby mode\*, watch mode\*, subactive mode\*, and subsleep mode\*, the PSW continues the operation as long as the clocks are supplied by the X1 and X2 pins. The PSW can also be initialized to H'00 by setting the TMA3 and TMA2 bits of the timer mode register A (TMA) to 11.

Note: \* When the timer A is in module stop mode, the operation is stopped.

Figure 22.2 shows the supply of the clocks to the peripheral function by the PSS and PSW.

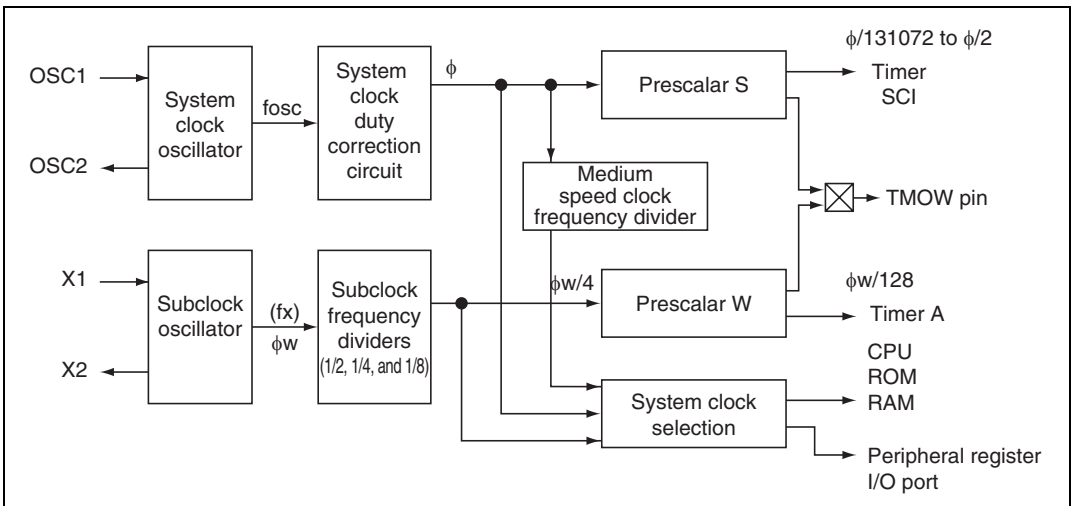


Figure 22.2 Clock Supply

### 22.4.3 Stable Oscillation Wait Time Count

For the count of the stable oscillation stable wait time during the return from the low power consumption mode excluding the sleep mode, see section 4, Power-Down State.

#### 22.4.4 8-Bit PWM

This 8-bit PWM controls the duty control PWM signal in the conversion cycle 256 states. It counts the cycle and the duty cycle at  $2^7$  to  $2^0$  of the FRC. It can be used for controlling reel motors and loading motors. For details, see section 19, 8-Bit PWM.

#### 22.4.5 8-Bit Input Capture Using $\overline{IC}$ Pin

This function catches the 8-bit data of  $2^{15}$  to  $2^8$  of the FRC according to the edge of the  $\overline{IC}$  pin. It can be used for remote control receiving.

For the edge of the  $\overline{IC}$  pin, the rising and falling edges can be selected.

The  $\overline{IC}$  pin has a built-in noise cancel circuit. See section 22.3, Noise Cancel Circuit.

An interrupt request is generated due to the input capture using the  $\overline{IC}$  pin.

Note: Rewriting the ICEG bit, NCon/off bit, or PMR16 bit is incorrectly recognized as edge detection according to the combinations between the state and detection edge of the  $\overline{IC}$  pin and the ICIF bit may be set after up to  $384\phi$  seconds.

#### 22.4.6 Frequency Division Clock Output

The frequency division clock can be output from the TMOW pin. For the frequency division clock, eight types of clocks can be selected according to the DCS2 to DCS0 bits in PCSR.

The clock in which the system clock was frequency-divided is output in active mode and sleep mode and the clock in which the subclock was frequency-divided is output in active mode\*, sleep mode\*, and subactive mode.

Note: \* When the timer A is in module stop mode, no clock is output.



## Section 23 Serial Communication Interface 1 (SCI1)

### 23.1 Overview

The serial communication interface 1 (SCI1) can handle both asynchronous and clocked synchronous serial communication. A function is also provided for serial communication between processors (multiprocessor communication function).

#### 23.1.1 Features

SCI1 features are listed below.

##### (1) Choice of asynchronous or clock synchronous serial communication mode

###### Asynchronous mode

- Serial data communication is executed using an asynchronous system in which synchronization is achieved character by character
- Serial data communication can be carried out with standard asynchronous communication chips such as a Universal Asynchronous Receiver/Transmitter (UART) or Asynchronous Communication Interface Adapter (ACIA)
- A multiprocessor communication function is provided that enables serial data communication with a number of processors
- Choice of 12 serial data transfer formats
- Data length: 7 or 8 bits
- Stop bit length: 1 or 2 bits
- Parity: Even, odd, or none
- Multiprocessor bit: 1 or 0
- Receive error detection: Parity, overrun, and framing errors
- Break detection: Break can be detected by reading the SII pin level directly in case of a framing error

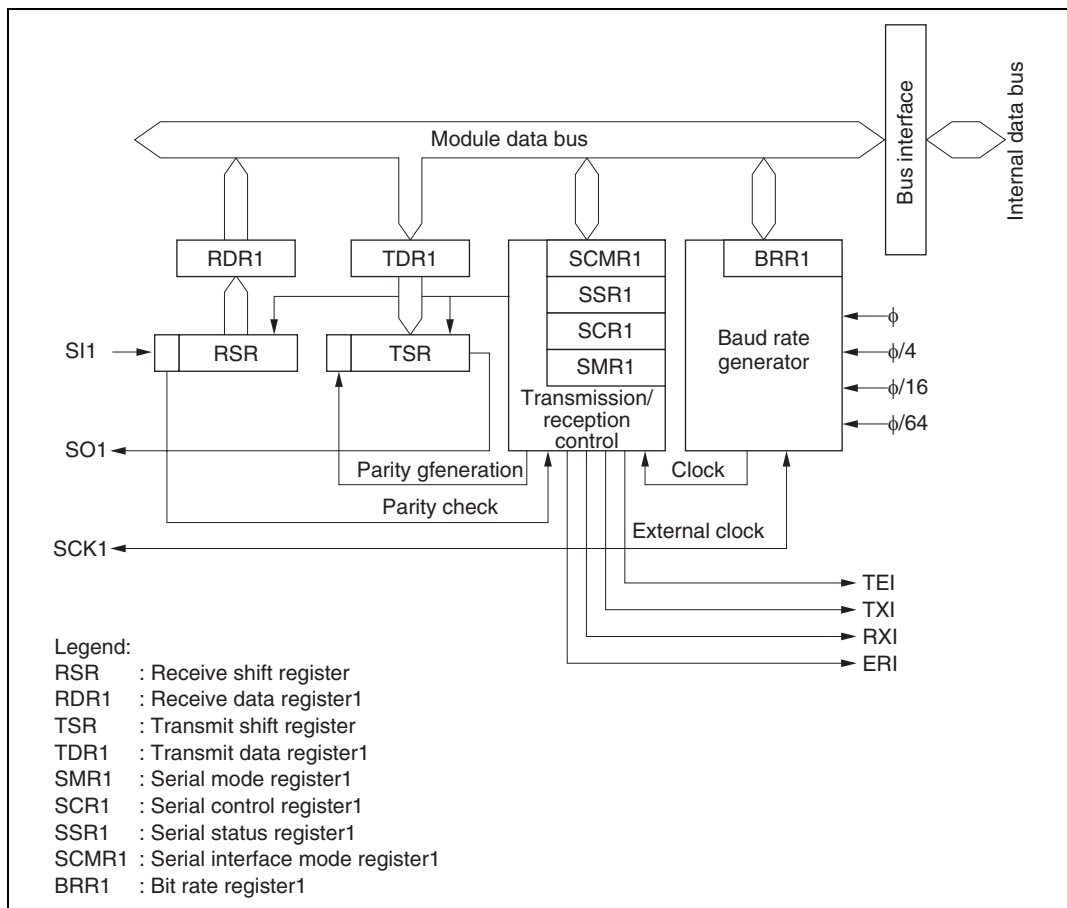
###### Clock synchronous mode

- Serial data communication is synchronized with a clock
- Serial data communication can be carried out with other chips that have a synchronous communication function
- One serial data transfer format
- Data length: 8 bits
- Receive error detection: Overrun errors detected

- (2) Full-duplex communication capability
  - The transmitter and receiver are mutually independent, enabling transmission and reception to be executed simultaneously
  - Double-buffering is used in both the transmitter and the receiver, enabling continuous transmission and continuous reception of serial data
- (3) Built-in baud rate generator allows any bit rate to be selected
- (4) Choice of serial clock source: internal clock from baud rate generator or external clock from SCK1 pin
- (5) Four interrupt sources
  - Four interrupt sources (transmit-data-empty, transmit-end, receive-data-full, and receive error) that can issue requests independently

### 23.1.2 Block Diagram

Figure 23.1 shows a block diagram of the SCI1.



**Figure 23.1 Block Diagram of SCI1**

### 23.1.3 Pin Configuration

Table 23.1 shows the serial pins used by the SCI1.

**Table 23.1 SCI Pins**

Channel	Pin Name	Symbol	I/O	Function
1	Serial clock pin 1	SCK1	I/O	SCI1 clock input/output
	Receive data pin 1	SI1	Input	SCI1 receive data input
	Transmit data pin 1	SO1	Output	SCI1 transmit data output

### 23.1.4 Register Configuration

The SCI1 has the internal registers shown in table 23.2. These registers are used to specify asynchronous mode or synchronous mode, the data format, and the bit rate, and to control the transmitter/receiver.

**Table 23.2 SCI Registers**

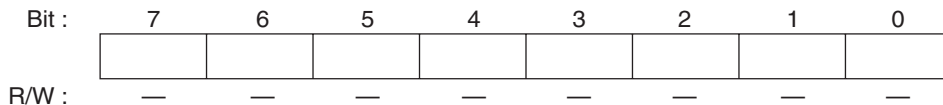
Channel	Name	Abbrev.	R/W	Initial Value	Address <sup>*1</sup>
1	Serial mode register 1	SMR1	R/W	H'00	H'D148
	Bit rate register 1	BRR1	R/W	H'FF	H'D149
	Serial control register 1	SCR1	R/W	H'00	H'D14A
	Transmit data register 1	TDR1	R/W	H'FF	H'D14B
	Serial status register 1	SSR1	R/(W) <sup>*2</sup>	H'84	H'D14C
	Receive data register 1	RDR1	R	H'00	H'D14D
	Serial interface mode register 1	SCMR1	R/W	H'F2	H'D14E
Common	Module stop control register	MSTPCRH	R/W	H'FF	H'FFEC
		MSTPCRL	R/W	H'FF	H'FFED

- Notes: 1. Lower 16 bits of the address.  
2. Only 0 can be written, to clear flags.



## 23.2 Register Descriptions

### 23.2.1 Receive Shift Register (RSR)

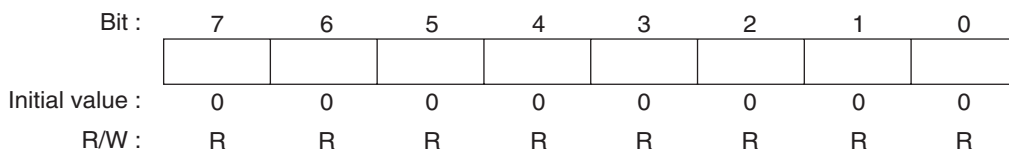


RSR is a register used to receive serial data.

The SCI1 sets serial data input from the SII pin in RSR in the order received, starting with the LSB (bit 0), and converts it to parallel data. When one byte of data has been received, it is transferred to RDR1 automatically.

RSR cannot be directly read or written to by the CPU.

### 23.2.2 Receive Data Register (RDR1)



RDR1 is a register that stores received serial data.

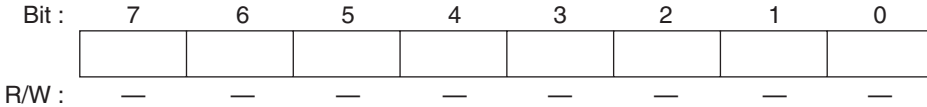
When the SCI1 has received one byte of serial data, it transfers the received serial data from RSR to RDR1 where it is stored, and completes the receive operation. After this, RSR is receive-enabled.

Since RSR and RDR1 function as a double buffer in this way, continuous receive operations can be performed.

RDR1 is a read-only register, and cannot be written to by the CPU.

RDR1 is initialized to H'00 by a reset, and in standby mode, watch mode, subactive mode, subsleep mode, and module stop mode.

### 23.2.3 Transmit Shift Register (TSR)



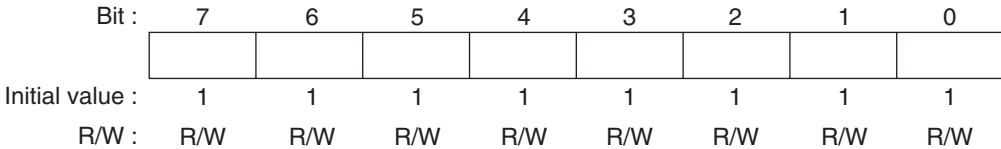
TSR is a register used to transmit serial data.

To perform serial data transmission, the SCI1 first transfers transmit data from TDR1 to TSR, then sends the data to the SO1 pin starting with the LSB (bit 0).

When transmission of one byte is completed, the next transmit data is transferred from TDR1 to TSR, and transmission started, automatically. However, data transfer from TDR1 to TSR is not performed if the TDRE bit in SSR1 is set to 1.

TSR cannot be directly read or written to by the CPU.

### 23.2.4 Transmit Data Register (TDR1)



TDR1 is an 8-bit register that stores data for serial transmission.

When the SCI1 detects that TSR is empty, it transfers the transmit data written in TDR1 to TSR and starts serial transmission. Continuous serial transmission can be carried out by writing the next transmit data to TDR1 during serial transmission of the data in TSR.

TDR1 can be read or written to by the CPU at all times.

TDR1 is initialized to H'FF by a reset, and in standby mode, watch mode, subactive mode, subsleep mode, and module stop mode.

### 23.2.5 Serial Mode Register (SMR1)

Bit :	7	6	5	4	3	2	1	0
	C/ $\bar{A}$	CHR	PE	O/ $\bar{E}$	STOP	MP	CKS1	CKS0
Initial value :	0	0	0	0	0	0	0	0
R/W :	R/W	R/W	R/W	R/W	R/W	R/W	R/W	R/W

SMR1 is an 8-bit register used to set the SCI1's serial transfer format and select the baud rate generator clock source.

SMR1 can be read or written to by the CPU at all times.

SMR1 is initialized to H'00 by a reset, and in standby mode, watch mode, subactive mode, subsleep mode, and module stop mode.

**Bit 7—Communication Mode (C/ $\bar{A}$ ):** Selects asynchronous mode or clock synchronous mode as the SCI1 operating mode.

#### Bit 7

C/ $\bar{A}$	Description
0	Asynchronous mode (Initial value)
1	Clock synchronous mode

**Bit 6—Character Length (CHR):** Selects 7 or 8 bits as the data length in asynchronous mode. In synchronous mode, a fixed data length of 8 bits is used regardless of the CHR setting.

#### Bit 6

CHR	Description
0	8-bit data (Initial value)
1	7-bit data*

Note: \* When 7-bit data is selected, the MSB (bit 7) of TDR1 is not transmitted, and LSB-first/MSB-first selection is not available.

**Bit 5—Parity Enable (PE):** In asynchronous mode, selects whether or not parity bit addition is performed in transmission, and parity bit checking in reception. In synchronous mode, or when a multiprocessor format is used, parity bit addition and checking is not performed, regardless of the PE bit setting.

**Bit 5**

PE	Description
0	Parity bit addition and checking disabled (Initial value)
1	Parity bit addition and checking enabled*

Note: \* When the PE bit is set to 1, the parity (even or odd) specified by the  $O/\bar{E}$  bit is added to transmit data before transmission. In reception, the parity bit is checked for the parity (even or odd) specified by the  $O/\bar{E}$  bit.

**Bit 4—Parity Mode ( $O/\bar{E}$ ):** Selects either even or odd parity for use in parity addition and checking.

The  $O/\bar{E}$  bit setting is only valid when the PE bit is set to 1, enabling parity bit addition and checking, in asynchronous mode. The  $O/\bar{E}$  bit setting is invalid in synchronous mode, when parity bit addition and checking is disabled in asynchronous mode, and when a multiprocessor format is used.

**Bit 4**

$O/\bar{E}$	Description
0	Even parity* <sup>1</sup> (Initial value)
1	Odd parity* <sup>2</sup>

Notes: 1. When even parity is set, parity bit addition is performed in transmission so that the total number of 1 bits in the transmit character plus the parity bit is even. In reception, a check is performed to see if the total number of 1 bits in the receive character plus the parity bit is even.

2. When odd parity is set, parity bit addition is performed in transmission so that the total number of 1 bits in the transmit character plus the parity bit is odd. In reception, a check is performed to see if the total number of 1 bits in the receive character plus the parity bit is odd.

**Bit 3—Stop Bit Length (STOP):** Selects 1 or 2 bits as the stop bit length in asynchronous mode. The STOP bit setting is only valid in asynchronous mode. If synchronous mode is set the STOP bit setting is invalid since stop bits are not added.

**Bit 3**

STOP	Description
0	1 stop bit* <sup>1</sup> (Initial value)
1	2 stop bits* <sup>2</sup>

Notes: 1. In transmission, a single 1 bit (stop bit) is added to the end of a transmit character before it is sent.  
 2. In transmission, two 1 bits (stop bits) are added to the end of a transmit character before it is sent.

In reception, only the first stop bit is checked, regardless of the STOP bit setting. If the second stop bit is 1, it is treated as a stop bit; if it is 0, it is treated as the start bit of the next transmit character.

**Bit 2—Multiprocessor Mode (MP):** Selects multiprocessor format. When multiprocessor format is selected, the PE bit and  $O/\bar{E}$  bit parity settings are invalid. The MP bit setting is only valid in asynchronous mode; it is invalid in synchronous mode.

For details of the multiprocessor communication function, see section 23.3.3, Multiprocessor Communication Function.

**Bit 2**

MP	Description
0	Multiprocessor function disabled (Initial value)
1	Multiprocessor format selected

**Bits 1 and 0—Clock Select 1 and 0 (CKS1, CKS0):** These bits select the clock source for the baud rate generator. The clock source can be selected from  $\phi$ ,  $\phi/4$ ,  $\phi/16$ , and  $\phi/64$ , according to the setting of bits CKS1 and CKS0.

For the relation between the clock source, the bit rate register setting, and the baud rate, see section 23.2.8, Bit Rate Register (BRR1).

Bit 1	Bit 0	Description	
CKS1	CKS0		
0	0	$\phi$ clock	(Initial value)
	1	$\phi/4$ clock	
1	0	$\phi/16$ clock	
	1	$\phi/64$ clock	

### 23.2.6 Serial Control Register (SCR1)

Bit :	7	6	5	4	3	2	1	0
	TIE	RIE	TE	RE	MPIE	TEIE	CKE1	CKE0
Initial value :	0	0	0	0	0	0	0	0
R/W :	R/W	R/W	R/W	R/W	R/W	R/W	R/W	R/W

SCR1 is a register that performs enabling or disabling of SCI1 transfer operations, serial clock output in asynchronous mode, and interrupt requests, and selection of the serial clock source. SCR1 can be read or written to by the CPU at all times.

SCR1 is initialized to H'00 by a reset, and in standby mode, watch mode, subactive mode, subsleep mode, and module stop mode.

**Bit 7—Transmit Interrupt Enable (TIE):** Enables or disables transmit-data-empty interrupt (TXI) request generation when serial transmit data is transferred from TDR1 to TSR and the TDRE flag in SSR1 is set to 1.

#### Bit 7

TIE	Description	
0	Transmit-data-empty interrupt (TXI) request disabled*	(Initial value)
1	Transmit-data-empty interrupt (TXI) request enabled	

Note: \* TXI interrupt request cancellation can be performed by reading 1 from the TDRE flag, then clearing it to 0, or clearing the TIE bit to 0.

**Bit 6—Receive Interrupt Enable (RIE):** Enables or disables receive-data-full interrupt (RXI) request and receive-error interrupt (ERI) request generation when serial receive data is transferred from RSR to RDR1 and the RDRF flag in SSR1 is set to 1.

**Bit 6**

RIE	Description
0	Receive-data-full interrupt (RXI) request and receive-error interrupt (ERI) request disabled* (Initial value)
1	Receive-data-full interrupt (RXI) request and receive-error interrupt (ERI) request enabled

Note: \* RXI and ERI interrupt request cancellation can be performed by reading 1 from the RDRF, FER, PER, or ORER flag, then clearing the flag to 0, or clearing the RIE bit to 0.

**Bit 5—Transmit Enable (TE):** Enables or disables the start of serial transmission by the SCI1.

**Bit 5**

TE	Description
0	Transmission disabled* <sup>1</sup> (Initial value)
1	Transmission enabled* <sup>2</sup>

Notes: 1. The TDRE flag in SSR1 is fixed at 1.  
 2. In this state, serial transmission is started when transmit data is written to TDR1 and the TDRE flag in SSR1 is cleared to 0. SMR1 setting must be performed to decide the transmission format before setting the TE bit to 1.

**Bit 4—Receive Enable (RE):** Enables or disables the start of serial reception by the SCI1.

**Bit 4**

RE	Description
0	Reception disabled* <sup>1</sup> (Initial value)
1	Reception enabled* <sup>2</sup>

Notes: 1. Clearing the RE bit to 0 does not affect the RDRF, FER, PER, and ORER flags, which retain their states.  
 2. Serial reception is started in this state when a start bit is detected in asynchronous mode or serial clock input is detected in synchronous mode. SMR1 setting must be performed to decide the reception format before setting the RE bit to 1.

**Bit 3—Multiprocessor Interrupt Enable (MPIE):** Enables or disables multiprocessor interrupts. The MPIE bit setting is only valid in asynchronous mode when receiving with the MP bit in SMR1 set to 1.

The MPIE bit setting is invalid in clock synchronous mode or when the MP bit is cleared to 0.

**Bit 3**

MPIE	Description
0	Multiprocessor interrupts disabled (normal reception performed) (Initial value) [Clearing conditions] (1) When the MPIE bit is cleared to 0 (2) When data with MPB = 1 is received
1	Multiprocessor interrupts enabled* Receive interrupt (RXI) requests, receive-error interrupt (ERI) requests, and setting of the RDRF, FER, and ORER flags in SSR are disabled until data with the multiprocessor bit set to 1 is received.

Note: \* When receive data including MPB = 0 is received, receive data transfer from RSR to RDR1, receive error detection, and setting of the RDRF, FER, and ORER flags in SSR1, is not performed. When receive data with MPB = 1 is received, the MPB bit in SSR1 is set to 1, the MPIE bit is cleared to 0 automatically, and generation of RXI and ERI interrupts (when the TIE and RIE bits in SCR1 are set to 1) and FER and ORER flag setting is enabled.

**Bit 2—Transmit End Interrupt Enable (TEIE):** Enables or disables transmit-end interrupt (TEI) request generation if there is no valid transmit data in TDR1 when the MSB is transmitted.

**Bit 2**

TEIE	Description
0	Transmit-end interrupt (TEI) request disabled* (Initial value)
1	Transmit-end interrupt (TEI) request enabled*

Note: \* TEI cancellation can be performed by reading 1 from the TDRE flag in SSR1, then clearing it to 0 and clearing the TEND flag to 0, or clearing the TEIE bit to 0.

**Bits 1 and 0—Clock Enable 1 and 0 (CKE1, CKE0):** These bits are used to select the SCI1 clock source and enable or disable clock output from the SCK1 pin. The combination of the CKE1 and CKE0 bits determines whether the SCK1 pin functions as an I/O port, the serial clock output pin, or the serial clock input pin.

The setting of the CKE0 bit, however, is only valid for internal clock operation (CKE1 = 0) in asynchronous mode. The CKE0 bit setting is invalid in synchronous mode, and in the case of external clock operation (CKE1 = 1). Note that the SCI1's operating mode must be decided using



SMR1 before setting the CKE1 and CKE0 bits.

For details of clock source selection, see table 23.9.

Bit 1	Bit 0	Description	
CKE1	CKE0		
0	0	Asynchronous mode	Internal clock/SCK1 pin functions as I/O port <sup>*1</sup>
		Clock synchronous mode	Internal clock/SCK1 pin functions as serial clock output <sup>*1</sup>
	1	Asynchronous mode	Internal clock/SCK1 pin functions as clock output <sup>*2</sup>
		Clock synchronous mode	Internal clock/SCK1 pin functions as serial clock output
1	0	Asynchronous mode	External clock/SCK1 pin functions as clock input <sup>*3</sup>
		Clock synchronous mode	External clock/SCK1 pin functions as serial clock input
	1	Asynchronous mode	External clock/SCK1 pin functions as clock input <sup>*3</sup>
		Clock synchronous mode	External clock/SCK1 pin functions as serial clock input

Notes: 1. Initial value

2. Outputs a clock of the same frequency as the bit rate.

3. Inputs a clock with a frequency 16 times the bit rate.

### 23.2.7 Serial Status Register (SSR1)

Bit :	7	6	5	4	3	2	1	0
	TDRE	RDRF	ORER	FER	PER	TEND	MPB	MPBT
Initial value :	1	0	0	0	0	1	0	0
R/W :	R/(W)*	R/(W)*	R/(W)*	R/(W)*	R/(W)*	R	R	R/W

Note: \* Only 0 can be written to clear the flag.

SSR1 is an 8-bit register containing status flags that indicate the operating status of the SCI1, and multiprocessor bits.

SSR1 can be read or written to by the CPU at all times. However, 1 cannot be written to flags TDRE, RDRF, ORER, PER, and FER. Also note that in order to clear these flags they must be read as 1 beforehand. The TEND flag and MPB flag are read-only flags and cannot be modified.

SSR1 is initialized to H'84 by a reset, and in standby mode, watch mode, subactive mode, subsleep mode, and module stop mode.

**Bit 7—Transmit Data Register Empty (TDRE):** Indicates that data has been transferred from TDR1 to TSR and the next serial data can be written to TDR1.

**Bit 7**

TDRE	Description
0	[Clearing condition] When 0 is written in TDRE after reading TDRE = 1
1	[Setting conditions] (Initial value) (1) When the TE bit in SCR1 is 0 (2) When data is transferred from TDR1 to TSR and data can be written to TDR1

**Bit 6—Receive Data Register Full (RDRF):** Indicates that the received data is stored in RDR1.

**Bit 6**

RDRF	Description
0	[Clearing condition] (Initial value) When 0 is written in RDRF after reading RDRF = 1
1	[Setting condition] When serial reception ends normally and receive data is transferred from RSR to RDR1

Note: RDR1 and the RDRF flag are not affected and retain their previous values when an error is detected during reception or when the RE bit in SCR1 is cleared to 0.

If reception of the next data is completed while the RDRF flag is still set to 1, an overrun error will occur and the receive data will be lost.

**Bit 5—Overrun Error (ORER)**

Indicates that an overrun error occurred during reception, causing abnormal termination.

**Bit 5**

ORER	Description
0	[Clearing condition] (Initial value) <sup>*1</sup> When 0 is written in ORER after reading ORER = 1
1	[Setting condition] When the next serial reception is completed while RDRF = 1 <sup>*2</sup>

- Notes:
1. The ORER flag is not affected and retains its previous state when the RE bit in SCR1 is cleared to 0.
  2. The receive data prior to the overrun error is retained in RDR1, and the data received subsequently is lost. Also, subsequent serial reception cannot be continued while the ORER flag is set to 1. In clock synchronous mode, serial transmission cannot be continued, either.

**Bit 4—Framing Error (FER):** Indicates that a framing error occurred during reception in asynchronous mode, causing abnormal termination.

**Bit 4**

FER	Description
0	[Clearing condition] (Initial value) <sup>*1</sup> When 0 is written in FER after reading FER = 1
1	[Setting condition] When the SCI1 checks the stop bit at the end of the receive data when reception ends, and the stop bit is 0 <sup>*2</sup>

- Notes:
1. The FER flag is not affected and retains its previous state when the RE bit in SCR1 is cleared to 0.
  2. In 2-stop-bit mode, only the first stop bit is checked for a value of 1; the second stop bit is not checked. If a framing error occurs, the receive data is transferred to RDR1 but the RDRF flag is not set. Also, subsequent serial reception cannot be continued while the FER flag is set to 1. In clock synchronous mode, serial transmission cannot be continued, either.

**Bit 3—Parity Error (PER):** Indicates that a parity error occurred during reception using parity addition in asynchronous mode, causing abnormal termination.

**Bit 3**

PER	Description
0	[Clearing condition] (Initial value) <sup>*1</sup> When 0 is written in PER after reading PER = 1
1	[Setting condition] When, in reception, the number of 1 bits in the receive data plus the parity bit does not match the parity setting (even or odd) specified by the O/E bit in SMR1 <sup>*2</sup>

- Notes:
1. The PER flag is not affected and retains its previous state when the RE bit in SCR1 is cleared to 0.
  2. If a parity error occurs, the receive data is transferred to RDR1 but the RDRF flag is not set. Also, subsequent serial reception cannot be continued while the PER flag is set to 1. In clock synchronous mode, serial transmission cannot be continued, either.

**Bit 2—Transmit End (TEND):** Indicates that there is no valid data in TDR1 when the last bit of the transmit character is sent, and transmission has been ended.

The TEND flag is read-only and cannot be modified.

**Bit 2**

TEND	Description
0	[Clearing condition] When 0 is written in TDRE after reading TDRE = 1
1	[Setting conditions] (Initial value) (1) When the TE bit in SCR1 is 0 (2) When TDRE = 1 at transmission of the last bit of a 1-byte serial transmit character

**Bit 1—Multiprocessor Bit (MPB):** When reception is performed using a multiprocessor format in asynchronous mode, MPB stores the multiprocessor bit in the receive data. MPB is a read-only bit, and cannot be modified.

**Bit 1**

MPB	Description
0	[Clearing condition] (Initial value)* When data with a 0 multiprocessor bit is received
1	[Setting condition] When data with a 1 multiprocessor bit is received

Note: \* Retains its previous state when the RE bit in SCR1 is cleared to 0 with multiprocessor format.

**Bit 0—Multiprocessor Bit Transfer (MPBT):** When transmission is performed using a multiprocessor format in asynchronous mode, MPBT stores the multiprocessor bit to be added to the transmit data.

The MPBT bit setting is invalid when a multiprocessor format is not used, when not transmitting, and in synchronous mode.

**Bit 0**

MPBT	Description
0	Data with a 0 multiprocessor bit is transmitted (Initial value)
1	Data with a 1 multiprocessor bit is transmitted

### 23.2.8 Bit Rate Register (BRR1)

Bit :	7	6	5	4	3	2	1	0
	<input type="checkbox"/>	<input type="checkbox"/>	<input type="checkbox"/>	<input type="checkbox"/>	<input type="checkbox"/>	<input type="checkbox"/>	<input type="checkbox"/>	<input type="checkbox"/>
Initial value :	1	1	1	1	1	1	1	1
R/W :	R/W	R/W	R/W	R/W	R/W	R/W	R/W	R/W

BRR1 is an 8-bit register that sets the serial transfer bit rate in accordance with the baud rate generator operating clock selected by bits CKS1 and CKS0 in SMR1.

BRR1 can be read or written to by the CPU at all times.

BRR1 is initialized to H'FF by a reset, and in standby mode, watch mode, subactive mode, subsleep mode, and module stop mode.

Table 23.3 shows sample BRR1 settings in asynchronous mode, and table 23.4 shows sample BRR1 settings in clock synchronous mode.

Table 23.3 BRR1 Settings for Various Bit Rates (Asynchronous Mode)

Bit Rate (bits/s)	Operating Frequency $\phi$ (MHz)											
	2			2.097152			2.4576			3		
	n	N	Error (%)	n	N	Error (%)	n	N	Error (%)	n	N	Error (%)
110	1	141	0.03	1	148	-0.04	1	174	-0.26	1	212	0.03
150	1	103	0.16	1	108	0.21	1	127	0.00	1	155	0.16
300	0	207	0.16	0	217	0.21	0	255	0.00	1	77	0.16
600	0	103	0.16	0	108	0.21	0	127	0.00	0	155	0.16
1200	0	51	0.16	0	54	-0.70	0	63	0.00	0	77	0.16
2400	0	25	0.16	0	26	1.14	0	31	0.00	0	38	0.16
4800	0	12	0.16	0	13	-2.48	0	15	0.00	0	19	-2.34
9600	—	—	—	0	6	-2.48	0	7	0.00	0	9	-2.34
19200	—	—	—	—	—	—	0	3	0.00	0	4	-2.34
31250	0	1	0.00	—	—	—	0	—	—	0	2	0.00
38400	—	—	—	—	—	—	0	1	0.00	—	—	—

Bit Rate (bits/s)	Operating Frequency $\phi$ (MHz)											
	3.6864			4			4.9152			5		
	n	N	Error (%)	n	N	Error (%)	n	N	Error (%)	n	N	Error (%)
110	2	64	0.70	2	70	0.03	2	86	0.31	2	88	-0.25
150	1	191	0.00	1	207	0.16	1	255	0.00	2	64	0.16
300	1	95	0.00	1	103	0.16	1	127	0.00	1	129	0.16
600	0	191	0.00	0	207	0.16	0	255	0.00	1	64	0.16
1200	0	95	0.00	0	103	0.16	0	127	0.00	0	129	0.16
2400	0	47	0.00	0	51	0.16	0	63	0.00	0	64	0.16
4800	0	23	0.00	0	25	0.16	0	31	0.00	0	32	-1.36
9600	0	11	0.00	0	12	0.16	0	15	0.00	0	15	1.73
19200	0	5	0.00	—	—	—	0	7	0.00	0	7	1.73
31250	—	—	—	0	3	0.00	0	4	-1.70	0	4	0.00
38400	0	2	0.00	—	—	—	0	3	0.00	0	3	1.73

Bit Rate (bits/s)	Operating Frequency $\phi$ (MHz)											
	6			6.144			7.3728			8		
	n	N	Error (%)	n	N	Error (%)	n	N	Error (%)	n	N	Error (%)
110	2	106	-0.44	2	108	0.08	2	130	-0.07	2	141	0.03
150	2	77	0.16	2	79	0.00	2	95	0.00	2	103	0.16
300	1	155	0.16	1	159	0.00	1	191	0.00	1	207	0.16
600	1	77	0.16	1	79	0.00	1	95	0.00	1	103	0.16
1200	0	155	0.16	0	159	0.00	0	191	0.00	0	207	0.16
2400	0	77	0.16	0	79	0.00	0	95	0.00	0	103	0.16
4800	0	38	0.16	0	39	0.00	0	47	0.00	0	51	0.16
9600	0	19	-2.34	0	19	0.00	0	23	0.00	0	25	0.16
19200	0	9	-2.34	0	9	0.00	0	11	0.00	0	12	0.16
31250	0	5	0.00	0	5	2.40	—	—	—	0	7	0.00
38400	0	4	-2.34	0	4	0.00	0	5	0.00	—	—	—

Bit Rate (bits/s)	Operating Frequency $\phi$ (MHz)					
	9.8304			10		
	n	N	Error (%)	n	N	Error (%)
110	2	174	-0.26	2	177	-0.25
150	2	127	0.00	2	129	0.16
300	1	255	0.00	2	64	0.16
600	1	127	0.00	1	129	0.16
1200	0	255	0.00	1	64	0.16
2400	0	127	0.00	0	129	0.16
4800	0	63	0.00	0	64	0.16
9600	0	31	0.00	0	32	-1.36
19200	0	15	0.00	0	15	1.73
31250	0	9	-1.70	0	9	0.00
38400	0	7	0.00	0	7	1.73

Table 23.4 BRR1 Settings for Various Bit Rates (Clock Synchronous Mode)

Bit Rate (bits/s)	Operating Frequency $\phi$ (MHz)							
	2		4		8		10	
	n	N	n	N	n	N	n	N
110	3	70	—	—				
250	2	124	2	249	3	124	—	—
500	1	249	2	124	2	249	—	—
1 k	1	124	1	249	2	124	—	—
2.5 k	0	199	1	99	1	199	1	249
5 k	0	99	0	199	1	99	1	124
10 k	0	49	0	99	0	199	0	249
25 k	0	19	0	39	0	79	0	99
50 k	0	9	0	19	0	39	0	49
100 k	0	4	0	9	0	19	0	24
250 k	0	1	0	3	0	7	0	9
500 k	0	0*	0	1	0	3	0	4
1 M			0	0*	0	1		
2.5 M							0	0*
5 M								

## Legend:

Blank: Cannot be set.

—: Can be set, but there will be a degree of error.

\*: Continuous transfer is not possible.

Note: As far as possible, the setting should be made so that the error is no more than 1%.



The BRR1 setting is found from the following equations.

- Asynchronous mode:

$$N = \frac{\phi}{64 \times 2^{2n-1} \times B} \times 10^6 - 1$$

- Clock synchronous mode:

$$N = \frac{\phi}{8 \times 2^{2n-1} \times B} \times 10^6 - 1$$

Where

B: Bit rate (bits/s)

N: BRR1 setting for baud rate generator ( $0 \leq N \leq 255$ )

$\phi$ : Operating frequency (MHz)

n: Baud rate generator input clock ( $n = 0$  to  $3$ )

(See the table below for the relation between n and the clock.)

n	Clock	SMR1 Setting	
		CKS1	CKS0
0	$\phi$	0	0
1	$\phi/4$	0	1
2	$\phi/16$	1	0
3	$\phi/64$	1	1

The bit rate error in asynchronous mode is found from the following equation:

$$\text{Error (\%)} = \left\{ \frac{\phi \times 10^6}{(N + 1) \times B \times 64 \times 2^{2n-1}} - 1 \right\} \times 100$$

Table 23.5 shows the maximum bit rate for each frequency in asynchronous mode. Tables 23.6 and 23.7 show the maximum bit rates with external clock input.

**Table 23.5 Maximum Bit Rate for Each Frequency (Asynchronous Mode)**

$\phi$ (MHz)	Maximum Bit Rate (bits/s)	n	N
2	62500	0	0
2.097152	65536	0	0
2.4576	76800	0	0
3	93750	0	0
3.6864	115200	0	0
4	125000	0	0
4.9152	153600	0	0
5	156250	0	0
6	187500	0	0
6.144	192000	0	0
7.3728	230400	0	0
8	250000	0	0
9.8304	307200	0	0
10	312500	0	0

**Table 23.6 Maximum Bit Rate with External Clock Input (Asynchronous Mode)**

$\phi$ (MHz)	External Input Clock (MHz)	Maximum Bit Rate (bit/s)
2	0.5000	31250
2.097152	0.5243	32768
2.4576	0.6144	38400
3	0.7500	46875
3.6864	0.9216	57600
4	1.0000	62500
4.9152	1.2288	76800
5	1.2500	78125
6	1.5000	93750
6.144	1.5360	96000
7.3728	1.8432	115200
8	2.0000	125000
9.8304	2.4576	153600
10	2.5000	156250

**Table 23.7 Maximum Bit Rate with External Clock Input (Clock Synchronous Mode)**

$\phi$ (MHz)	External Input Clock (MHz)	Maximum Bit Rate (bit/s)
2	0.3333	333333.3
4	0.6667	666666.7
6	1.0000	1000000.0
8	1.3333	1333333.3
10	1.6667	1666666.7

**23.2.9 Serial Interface Mode Register (SCMR1)**

Bit :	7	6	5	4	3	2	1	0
	—	—	—	—	SDIR	SINV	—	SMIF
Initial value :	1	1	1	1	0	0	1	0
R/W :	—	—	—	—	R/W	R/W	—	R/W

SCMR1 is an 8-bit readable/writable register used to select SCI1 functions.

SCMR1 is initialized to HF2 by a reset, and in standby mode, watch mode, subactive mode, subsleep mode, and module stop mode.

**Bits 7 to 4—Reserved:** These bits cannot be modified and are always read as 1.

**Bit 3—Data Transfer Direction (SDIR):** Selects the serial/parallel conversion format.

**Bit 3**

SDIR	Description
0	TDR1 contents are transmitted LSB-first Receive data is stored in RDR1 LSB-first (Initial value)
1	TDR1 contents are transmitted MSB-first Receive data is stored in RDR1 MSB-first

**Bit 2—Data Invert (SINV):** Specifies inversion of the data logic level. The SINV bit does not affect the logic level of the parity bit(s); parity bit inversion requires inversion of the O/E bit in SMR1.

**Bit 2**

SINV	Description
0	TDR1 contents are transmitted without modification Receive data is stored in RDR1 without modification (Initial value)
1	TDR1 contents are inverted before being transmitted Receive data is stored in RDR1 in inverted form

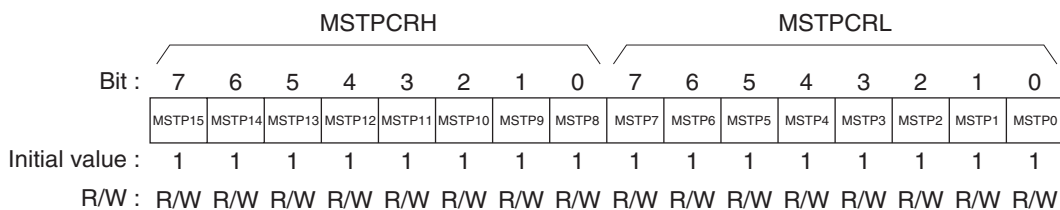
**Bit 1—Reserved:** This bit cannot be modified and is always read as 1.

**Bit 0—Serial Communication Interface Mode Select (SMIF):** 1 should not be written in this bit.

#### Bit 0

SMIF	Description
0	Normal SCI1 mode (Initial value)
1	Reserved mode

### 23.2.10 Module Stop Control Register (MSTPCR)



MSTPCR, comprising two 8-bit readable/writable registers, performs module stop mode control. When bit MSTP8 is set to 1, SCI1 operation stops at the end of the bus cycle and a transition is made to module stop mode. For details, see section 4.5, Module Stop Mode. MSTPCR is initialized to H'FFFF by a reset.

**Bit 0—Module Stop (MSTP8):** Specifies the SCI1 module stop mode.

#### MSTPCR<sub>H</sub>

#### Bit 0

MSTP8	Description
0	SCI1 module stop mode is cleared
1	SCI1 module stop mode is set (Initial value)

## 23.3 Operation

### 23.3.1 Overview

The SCI1 can carry out serial communication in two modes: asynchronous mode in which synchronization is achieved character by character, and synchronous mode in which synchronization is achieved with clock pulses.

Selection of asynchronous or synchronous mode and the transmission format is made using SMR1 as shown in table 23.8. The SCI1 clock is determined by a combination of the  $C/\bar{A}$  bit in SMR1 and the CKE1 and CKE0 bits in SCR1, as shown in table 23.9.

#### (1) Asynchronous Mode

- Data length: Choice of 7 or 8 bits
- Choice of parity addition, multiprocessor bit addition, and addition of 1 or 2 stop bits (the combination of these parameters determines the transfer format and character length)
- Detection of framing, parity, and overrun errors, and breaks, during reception
- Choice of internal or external clock as SCI1 clock source
  - When internal clock is selected:  
The SCI1 operates on the baud rate generator clock and a clock with the same frequency as the bit rate can be output
  - When external clock is selected:  
A clock with a frequency of 16 times the bit rate must be input (the built-in baud rate generator is not used)

#### (2) Clock Synchronous Mode

- Transfer format: Fixed 8-bit data
- Detection of overrun errors during reception
- Choice of internal or external clock as SCI1 clock source
  - When internal clock is selected:  
The SCI1 operates on the baud rate generator clock and a serial clock is output off-chip
  - When external clock is selected:  
The built-in baud rate generator is not used, and the SCI1 operates on the input serial clock

Table 23.8 SMR1 Settings and Serial Transfer Format Selection

SMR1 Settings					SCI1 Transfer Format					
Bit 7	Bit 6	Bit 2	Bit 5	Bit 3	Mode	Data length	Multiproc-processor bit	Parity bit	Stop bit length	
C/ $\bar{A}$	CHR	MP	PE	STOP						
0	0	0	0	0	Asynchro-nous mode	8-bit data	No	No	1 bit	
				1					2 bits	
				0					1 bit	
				1					2 bits	
	1	0	0	0	1	7-bit data			No	1 bit
					1					2 bits
					0					1 bit
					1					2 bits
0	1	—	0	0	Asynchro-nous mode (multi-processor format)	8-bit data	Yes	No	1 bit	
				1					2 bits	
				0					1 bit	
				1					2 bits	
1	—	—	—	—	Clock synchronous mode	8-bit data	No			

Table 23.9 SMR1 and SCR1 Settings and SCI1 Clock Source Selection

SMR1			SCR1 Setting		SCI1 Transfer Clock	
Bit 7	Bit 1	Bit 0	Mode	Clock Source	SCK1 Pin Function	
C/ $\bar{A}$	CKE1	CKE0				
0	0	0	Asynchronous mode	Internal	SCI1 does not use SCK1 pin Outputs clock with same frequency as bit rate	
		1				
	1	0	External	Inputs clock with frequency of 16 times the bit rate		
		1				
1	0	0	Clock synchronous mode	Internal	Outputs serial clock	
		1				
	1	0	External	Inputs serial clock		
		1				

### 23.3.2 Operation in Asynchronous Mode

In asynchronous mode, characters are sent or received, each preceded by a start bit indicating the start of communication and followed by one or two stop bits indicating the end of communication. Serial communication is thus carried out with synchronization established on a character-by-character basis.

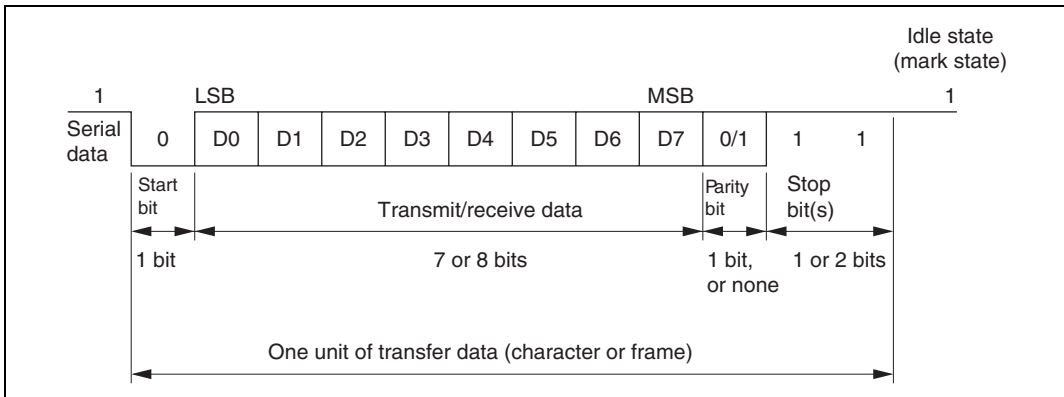
Inside the SCI1, the transmitter and receiver are independent units, enabling full-duplex communication. Both the transmitter and the receiver also have a double-buffered structure, so that data can be read or written during transmission or reception, enabling continuous data transfer.

Figure 23.2 shows the general format for asynchronous serial communication.

In asynchronous serial communication, the transmission line is usually held in the mark state (high level). The SCI1 monitors the transmission line, and when it goes to the space state (low level), recognizes a start bit and starts serial communication.

One serial communication character consists of a start bit (low level), followed by data (in LSB-first order), a parity bit (high or low level), and finally one or two stop bits (high level).

In asynchronous mode, the SCI1 performs synchronization at the falling edge of the start bit in reception. The SCI1 samples the data on the 8th pulse of a clock with a frequency of 16 times the length of one bit, so that the transfer data is latched at the center of each bit.



**Figure 23.2 Data Format in Asynchronous Communication  
(Example with 8-Bit Data, Parity, Two Stop Bits)**



## (1) Data Transfer Format

Table 23.10 shows the data transfer formats that can be used in asynchronous mode. Any of 12 transfer formats can be selected by settings in SMR1.

**Table 23.10 Serial Transfer Formats (Asynchronous Mode)**

SMR1 Settings				Serial Transfer Format and Frame Length														
CHR	PE	MP	STOP	1	2	3	4	5	6	7	8	9	10	11	12			
0	0	0	0	S	8-bit data								STOP					
0	0	0	1	S	8-bit data								STOP	STOP				
0	1	0	0	S	8-bit data								P	STOP				
0	1	0	1	S	8-bit data								P	STOP	STOP			
1	0	0	0	S	7-bit data							STOP						
1	0	0	1	S	7-bit data							STOP	STOP					
1	1	0	0	S	7-bit data							P	STOP					
1	1	0	1	S	7-bit data							P	STOP	STOP				
0	—	1	0	S	8-bit data								MPB	STOP				
0	—	1	1	S	8-bit data								MPB	STOP	STOP			
1	—	1	0	S	7-bit data							MPB	STOP					
1	—	1	1	S	7-bit data							MPB	STOP	STOP				

## Legend:

S : Start bit

STOP : Stop bit

P : Parity bit

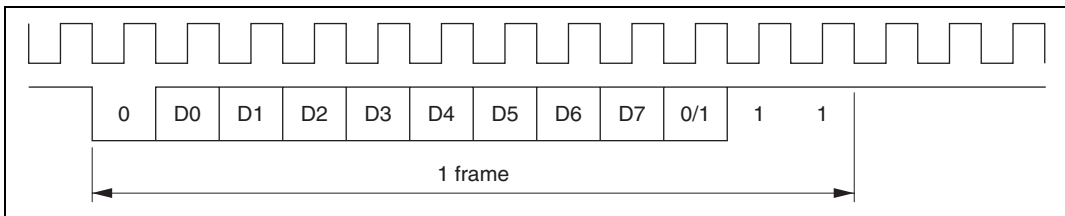
MPB : Multiprocessor bit

## (2) Clock

Either an internal clock generated by the built-in baud rate generator or an external clock input at the SCK1 pin can be selected as the SCI1's serial clock, according to the setting of the  $C/\bar{A}$  bit in SMR1 and the CKE1 and CKE0 bits in SCR1. For details of SCI1 clock source selection, see table 23.9.

When an external clock is input at the SCK1 pin, the clock frequency should be 16 times the bit rate used.

When the SCI1 is operated on an internal clock, the clock can be output from the SCK1 pin. The frequency of the clock output in this case is equal to the bit rate, and the phase is such that the rising edge of the clock is at the center of each transmit data bit, as shown in figure 23.3.



**Figure 23.3 Relation between Output Clock and Transfer Data Phase  
(Asynchronous Mode)**

## (3) Data Transfer Operations

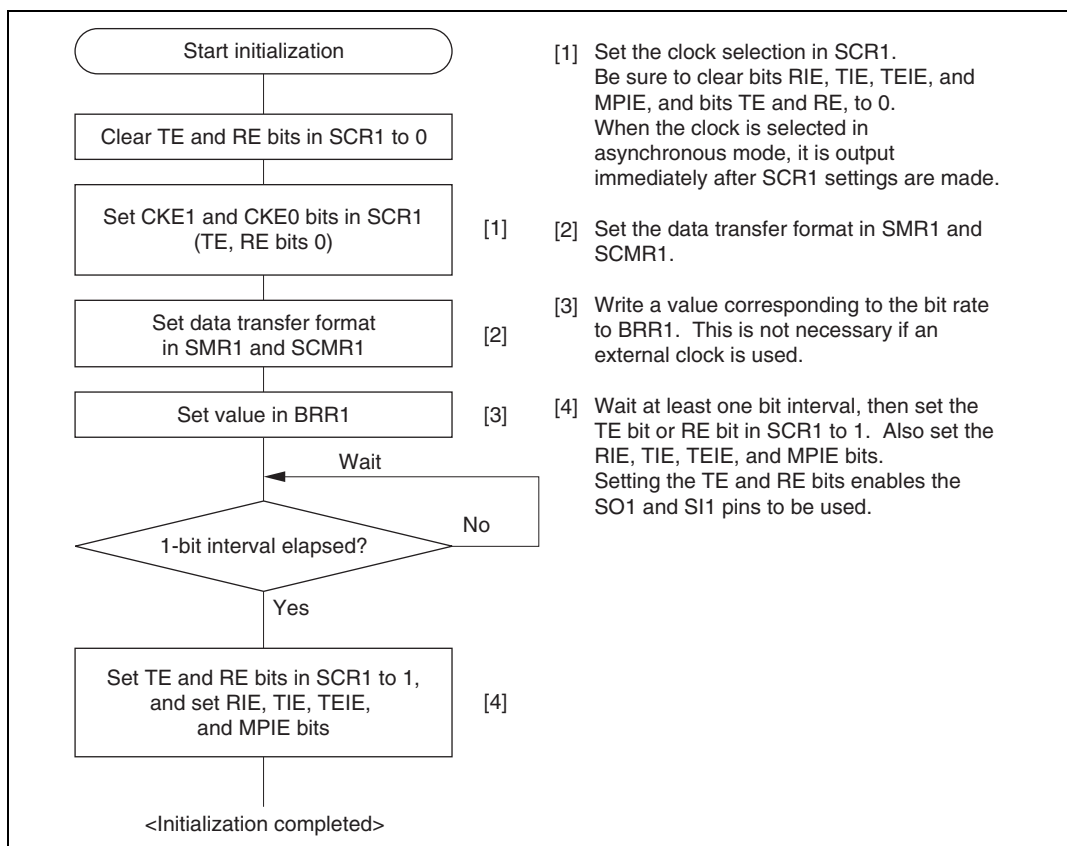
## (a) SCI1 Initialization (Asynchronous Mode)

Before transmitting and receiving data, first clear the TE and RE bits in SCR1 to 0, then initialize the SCI1 as described below.

When the operating mode, transfer format, etc., is changed, the TE and RE bits must be cleared to 0 before making the change using the following procedure. When the TE bit is cleared to 0, the TDRE flag is set to 1 and TSR is initialized. Note that clearing the RE bit to 0 does not change the contents of the RDRF, PER, FER, and ORER flags, or the contents of RDR1.

When an external clock is used the clock should not be stopped during operation, including initialization, since operation is uncertain.

Figure 23.4 shows a sample SCI1 initialization flowchart.

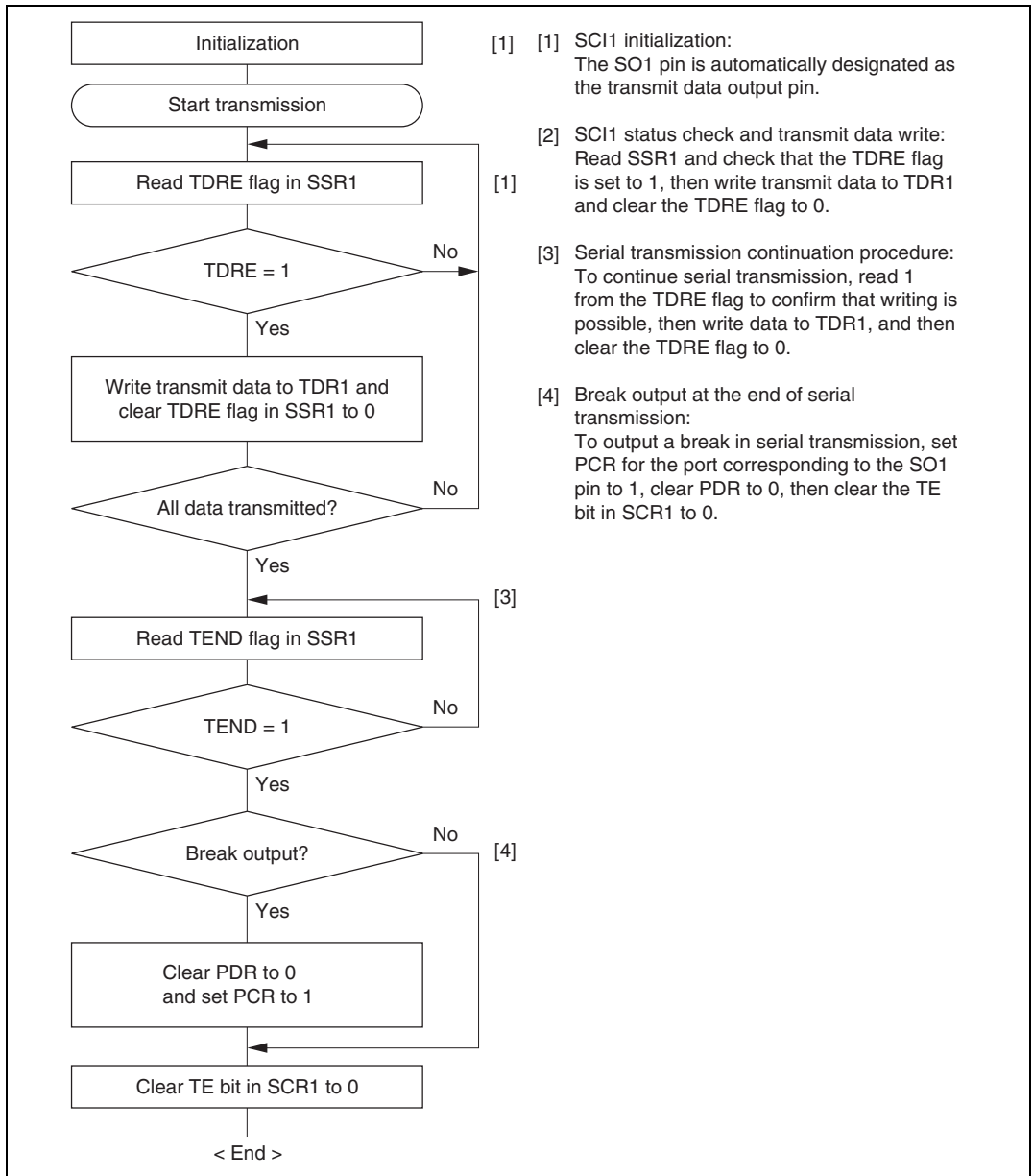


**Figure 23.4 Sample SCI Initialization Flowchart**

## (b) Serial Data Transmission (Asynchronous Mode)

Figure 23.5 shows a sample flowchart for serial transmission.

The following procedure should be used for serial data transmission.



**Figure 23.5 Sample Serial Transmission Flowchart**

In serial transmission, the SCI1 operates as described below.

[1] The SCI1 monitors the TDRE flag in SSR1, and if it is 0, recognizes that data has been written to TDR1, and transfers the data from TDR1 to TSR.

[2] After transferring data from TDR1 to TSR, the SCI1 sets the TDRE flag to 1 and starts transmission.

If the TIE bit is set to 1 at this time, a transmit data empty interrupt (TXI) is generated.

The serial transmit data is sent from the SO1 pin in the following order.

[a] Start bit:

One 0-bit is output.

[b] Transmit data:

8-bit or 7-bit data is output in LSB-first order.

[c] Parity bit or multiprocessor bit:

One parity bit (even or odd parity), or one multiprocessor bit is output.

A format in which neither a parity bit nor a multiprocessor bit is output can also be selected.

[d] Stop bit(s):

One or two 1-bits (stop bits) are output.

[e] Mark state:

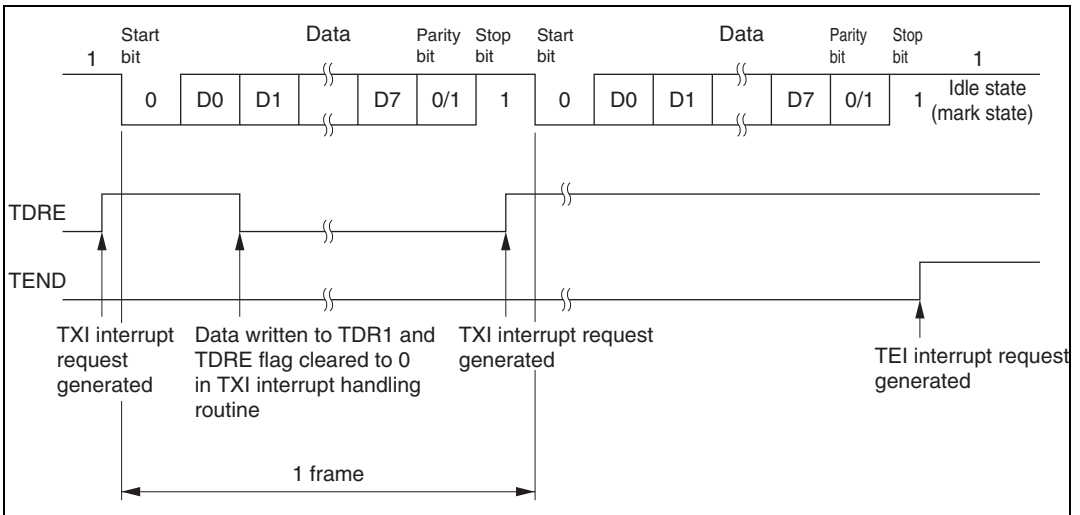
1 is output continuously until the start bit that starts the next transmission is sent.

[3] The SCI1 checks the TDRE flag at the timing for sending the stop bit.

If the TDRE flag is cleared to 0, the data is transferred from TDR1 to TSR, the stop bit is sent, and then serial transmission of the next frame is started.

If the TDRE flag is set to 1, the TEND flag in SSR1 is set to 1, the stop bit is sent, and then the mark state is entered in which 1 is output continuously. If the TEIE bit in SCR1 is set to 1 at this time, a TEI interrupt request is generated.

Figure 23.6 shows an example of the operation for transmission in asynchronous mode.



**Figure 23.6 Example of Operation in Transmission in Asynchronous Mode  
(Example with 8-Bit Data, Parity, One Stop Bit)**

## (c) Serial Data Reception (Asynchronous Mode)

Figure 23.7 shows a sample flowchart for serial reception.

The following procedure should be used for serial data reception.

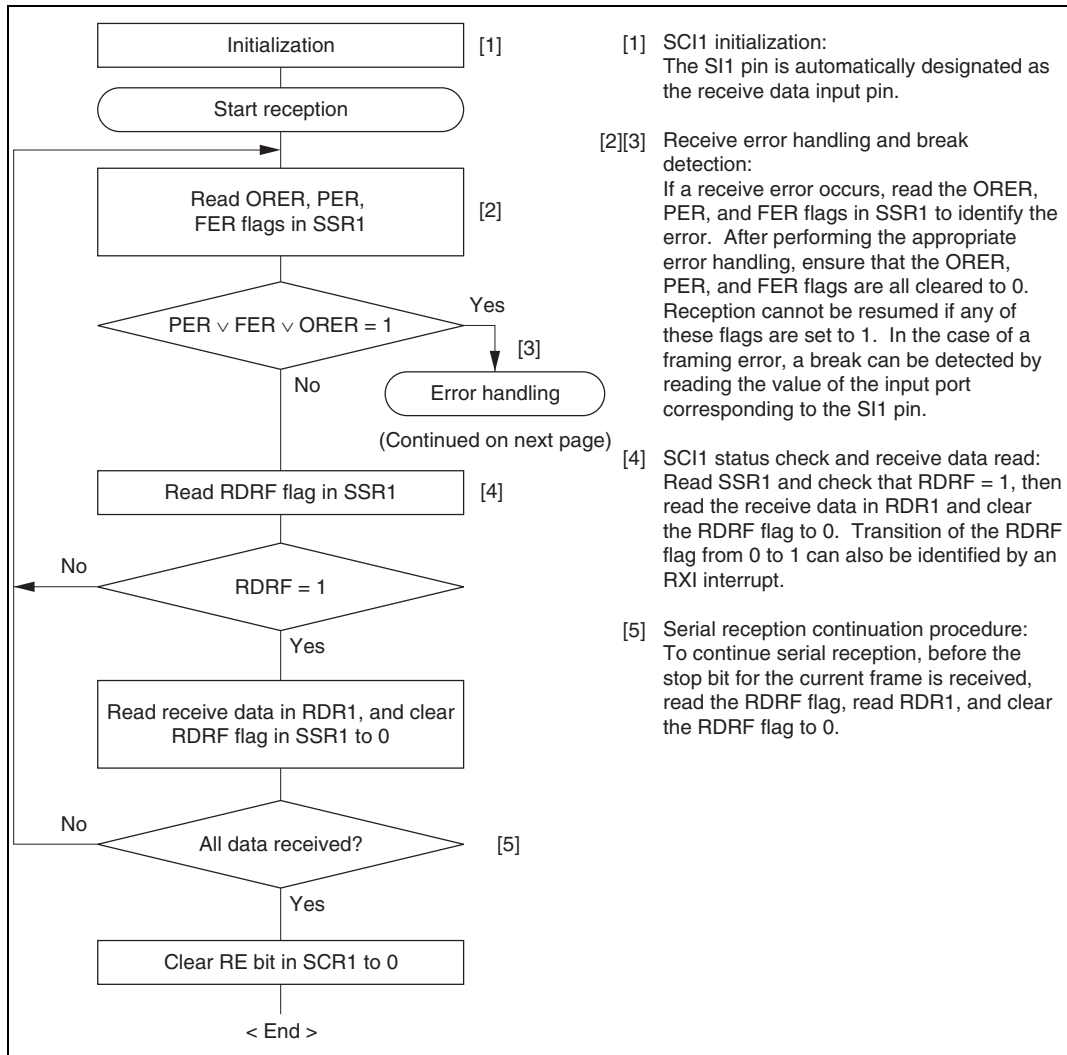


Figure 23.7 Sample Serial Reception Data Flowchart (1)

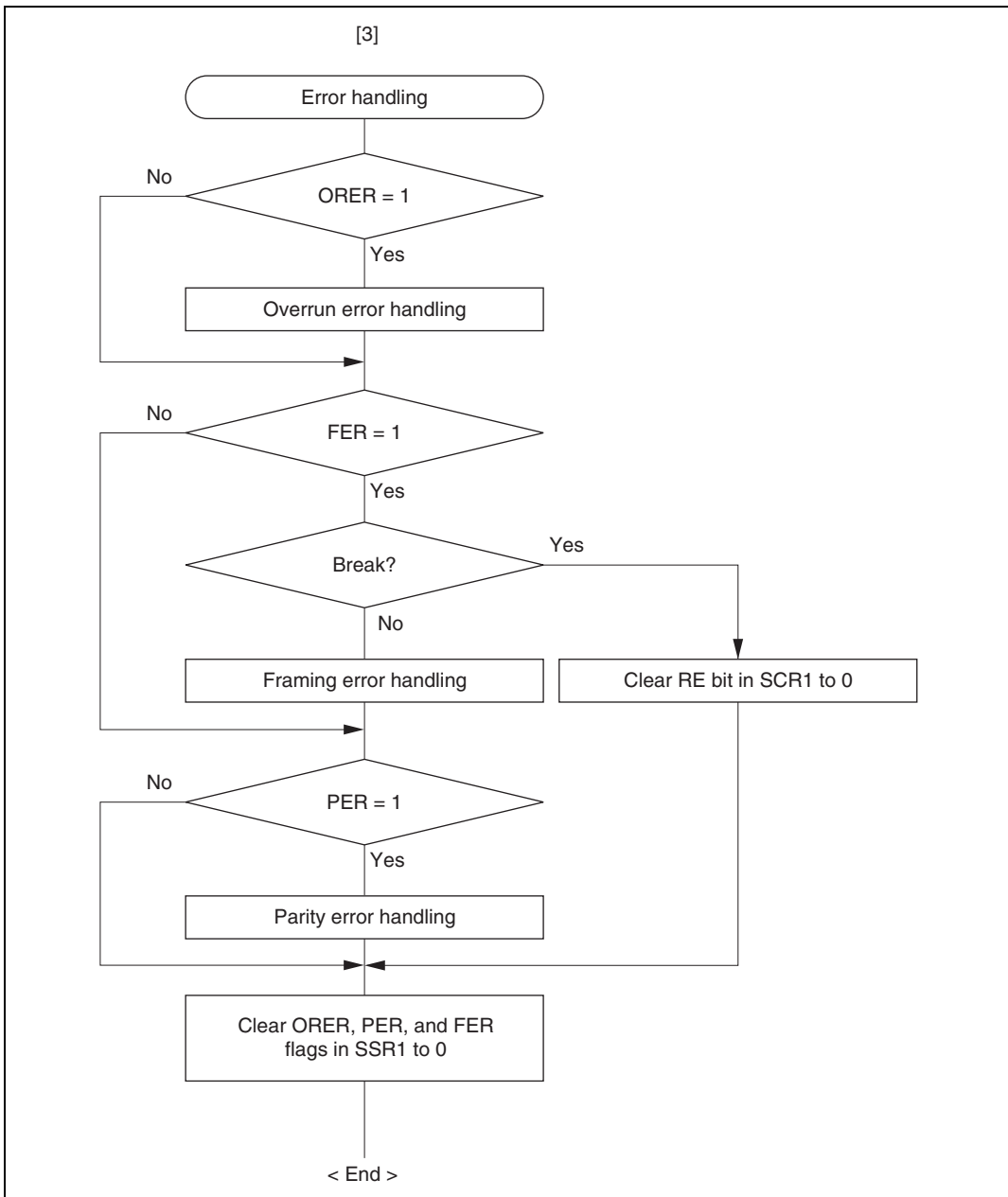


Figure 23.7 Sample Serial Reception Data Flowchart (2)



In serial reception, the SCI1 operates as described below.

- [1] The SCI1 monitors the transmission line, and if a 0 stop bit is detected, performs internal synchronization and starts reception.
- [2] The received data is stored in RSR in LSB-to-MSB order.
- [3] The parity bit and stop bit are received.

After receiving these bits, the SCI1 carries out the following checks.

[a] Parity check:

The SCI1 checks whether the number of 1 bits in the receive data agrees with the parity (even or odd) set in the  $O/\bar{E}$  bit in SMR1.

[b] Stop bit check:

The SCI1 checks whether the stop bit is 1.

If there are two stop bits, only the first is checked.

[c] Status check:

The SCI1 checks whether the RDRF flag is 0, indicating that the receive data can be transferred from RSR to RDR1.

If all the above checks are passed, the RDRF flag is set to 1, and the receive data is stored in RDR1.

If a receive error\* is detected in the error check, the operation is as shown in table 23.11.

Note: \* Subsequent receive operations cannot be performed when a receive error has occurred. Also note that the RDRF flag is not set to 1 in reception, and so the error flags must be cleared to 0.

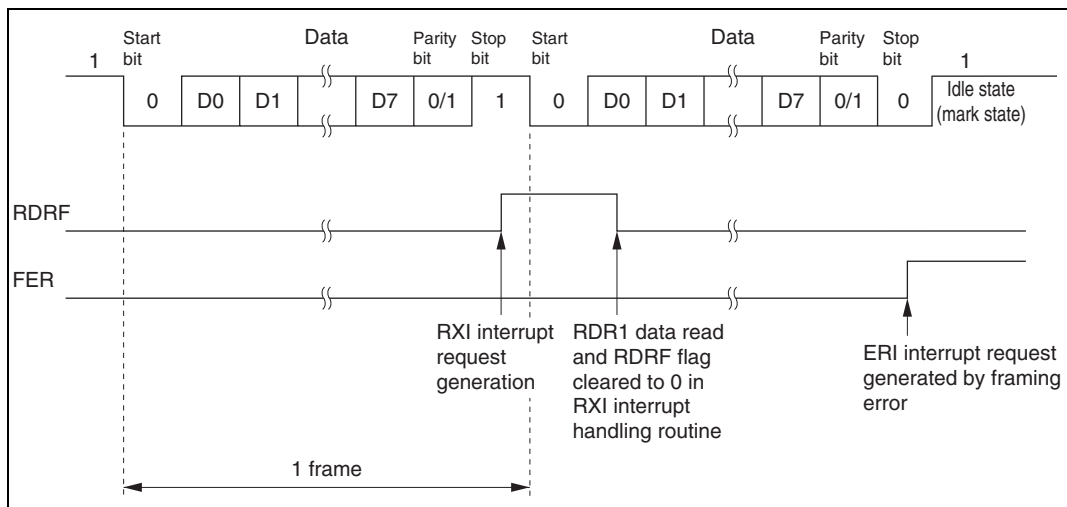
- [4] If the RIE bit in SCR1 is set to 1 when the RDRF flag changes to 1, a receive-data-full interrupt (RXI) request is generated.

Also, if the RIE bit in SCR1 is set to 1 when the ORER, PER, or FER flag changes to 1, a receive-error interrupt (ERI) request is generated.

**Table 23.11 Receive Errors and Conditions for Occurrence**

Receive Error	Abbrev.	Occurrence Condition	Data Transfer
Overrun error	ORER	When the next data reception is completed while the RDRF flag in SSR1 is set to 1	Receive data is not transferred from RSR to RDR1
Framing error	FER	When the stop bit is 0	Receive data is transferred from RSR to RDR1
Parity error	PER	When the received data differs from the parity (even or odd) set in SMR1	Receive data is transferred from RSR to RDR1

Figure 23.8 shows an example of the operation for reception in asynchronous mode.



**Figure 23.8 Example of SCI1 Operation in Reception**  
(Example with 8-Bit Data, Parity, One Stop Bit)

### 23.3.3 Multiprocessor Communication Function

The multiprocessor communication function performs serial communication using a multiprocessor format, in which a multiprocessor bit is added to the transfer data, in asynchronous mode. Use of this function enables data transfer to be performed among a number of processors sharing transmission lines.

When multiprocessor communication is carried out, each receiving station is addressed by a unique ID code.

The serial communication cycle consists of two component cycles: an ID transmission cycle which specifies the receiving station, and a data transmission cycle. The multiprocessor bit is used to differentiate between the ID transmission cycle and the data transmission cycle.

The transmitting station first sends the ID of the receiving station with which it wants to perform serial communication as data with a 1 multiprocessor bit added. It then sends transmit data as data with a 0 multiprocessor bit added.

The receiving station skips the data until data with a 1 multiprocessor bit is sent.

When data with a 1 multiprocessor bit is received, the receiving station compares that data with its own ID. The station whose ID matches then receives the data sent next. Stations whose ID does not match continue to skip the data until data with a 1 multiprocessor bit is again received. In this way, data communication is carried out among a number of processors.

Figure 23.9 shows an example of inter-processor communication using a multiprocessor format.

## (1) Data Transfer Format

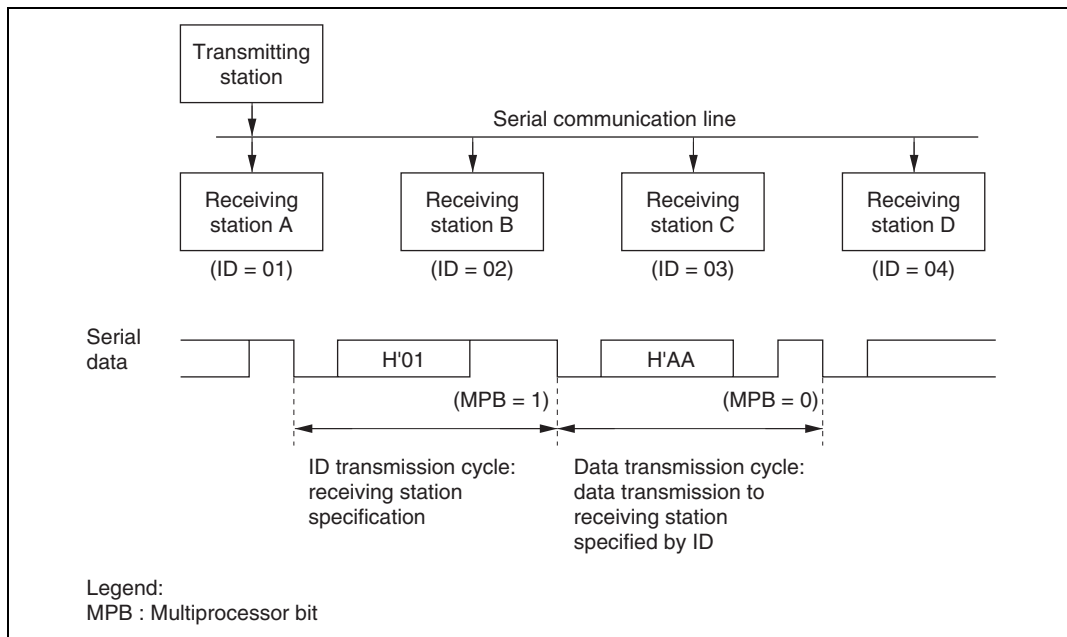
There are four data transfer formats.

When a multiprocessor format is specified, the parity bit specification is invalid.

For details, see table 23.10.

## (2) Clock

See the section on asynchronous mode.



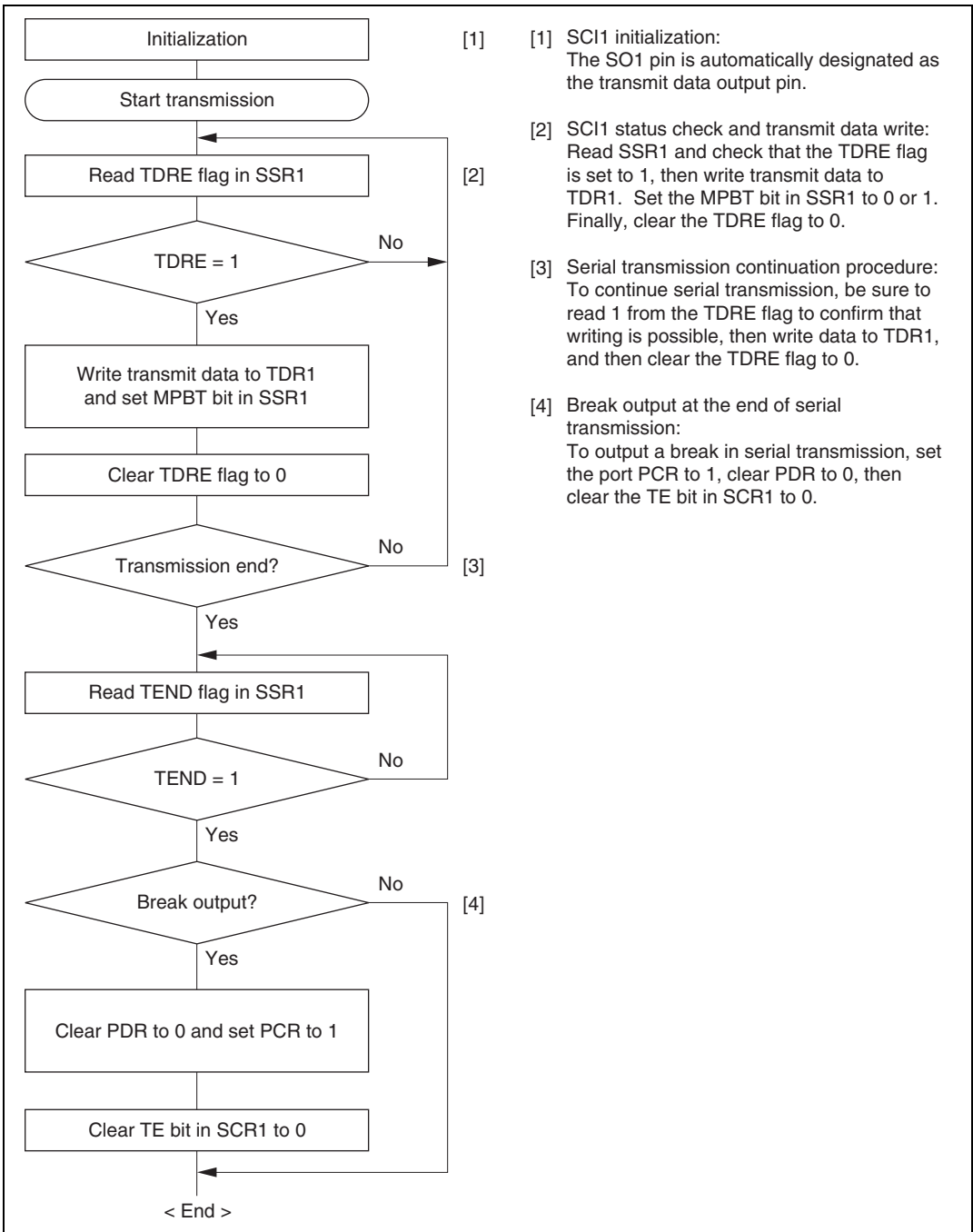
**Figure 23.9 Example of Inter-Processor Communication Using Multiprocessor Format  
(Transmission of Data H'AA to Receiving Station A)**

## (3) Data Transfer Operations

## (a) Multiprocessor Serial Data Transmission

Figure 23.10 shows a sample flowchart for multiprocessor serial data transmission.

The following procedure should be used for multiprocessor serial data transmission.



**Figure 23.10 Sample Multiprocessor Serial Transmission Flowchart**

In serial transmission, the SCI1 operates as described below.

[1] The SCI1 monitors the TDRE flag in SSR1, and if it is 0, recognizes that data has been written to TDR1, and transfers the data from TDR1 to TSR.

[2] After transferring data from TDR1 to TSR, the SCI1 sets the TDRE flag to 1 and starts transmission.

If the TIE bit is set to 1 at this time, a transmit-data-empty interrupt (TXI) is generated.

The serial transmit data is sent from the SO2 pin in the following order.

[a] Start bit:

One 0-bit is output.

[b] Transmit data:

8-bit or 7-bit data is output in LSB-first order.

[c] Multiprocessor bit

One multiprocessor bit (MPBT value) is output.

[d] Stop bit(s):

One or two 1-bits (stop bits) are output.

[e] Mark state:

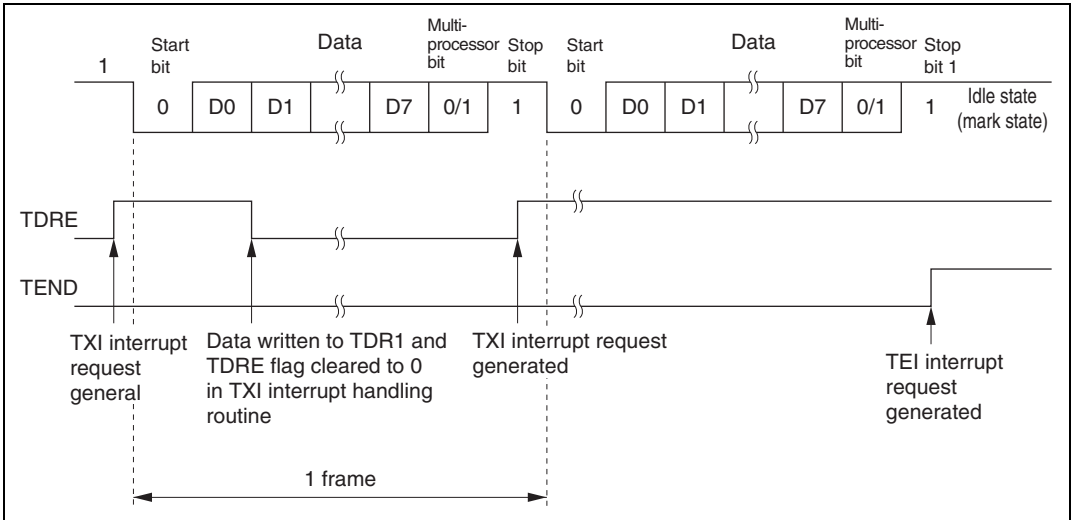
1 is output continuously until the start bit that starts the next transmission is sent.

[3] The SCI1 checks the TDRE flag at the timing for sending the stop bit.

If the TDRE flag is cleared to 0, data is transferred from TDR1 to TSR, the stop bit is sent, and then serial transmission of the next frame is started.

If the TDRE flag is set to 1, the TEND flag in SSR1 is set to 1, the stop bit is sent, and then the mark state is entered in which 1 is output continuously. If the TEIE bit in SCR1 is set to 1 at this time, a transmit-end interrupt (TEI) request is generated.

Figure 23.11 shows an example of SCI1 operation for transmission using a multiprocessor format.



**Figure 23.11 Example of SCI1 Operation in Transmission  
(Example with 8-Bit Data, Multiprocessor Bit, One Stop Bit)**

#### (b) Multiprocessor Serial Data Reception

Figure 23.12 shows a sample flowchart for multiprocessor serial reception.

The following procedure should be used for multiprocessor serial data reception.

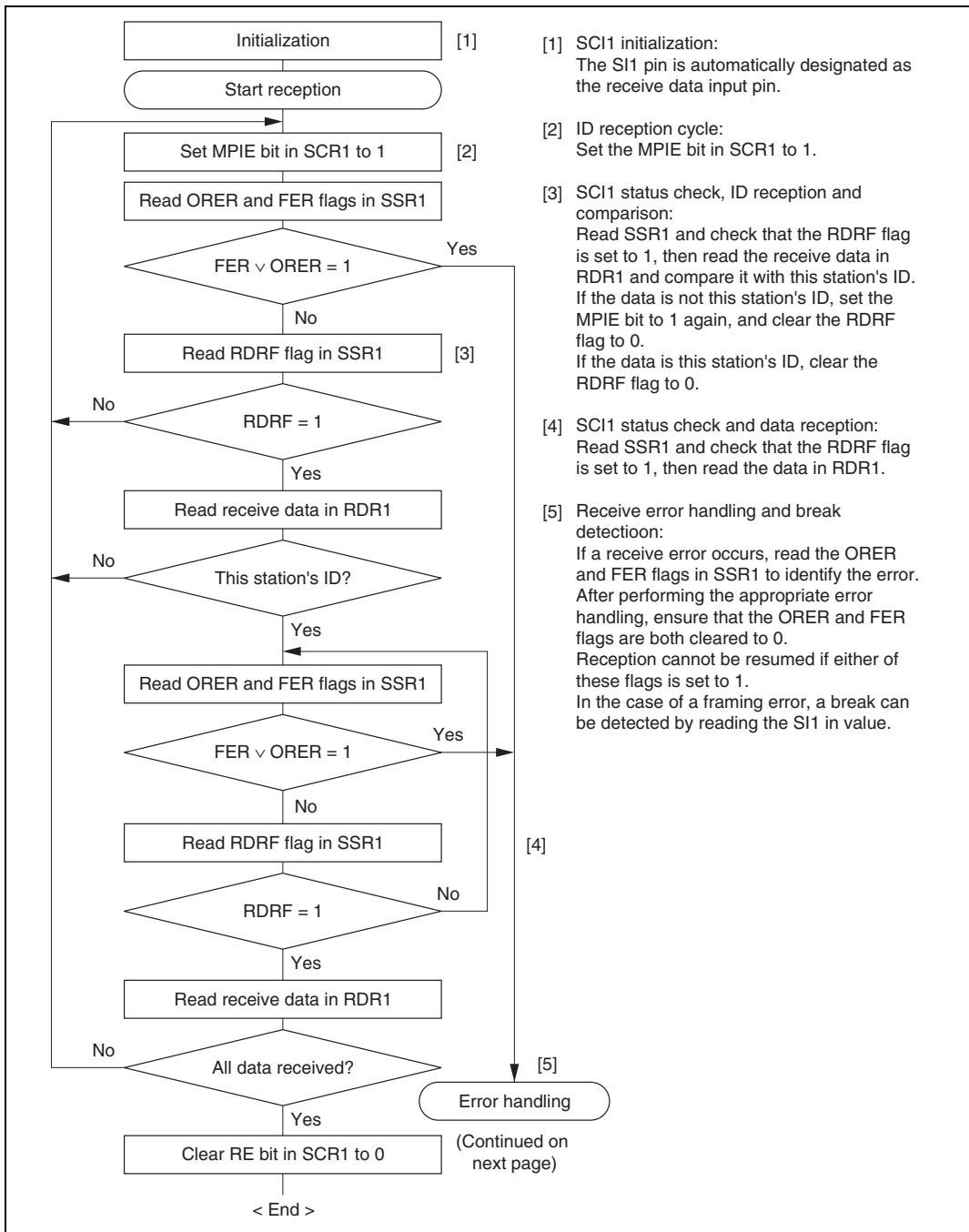
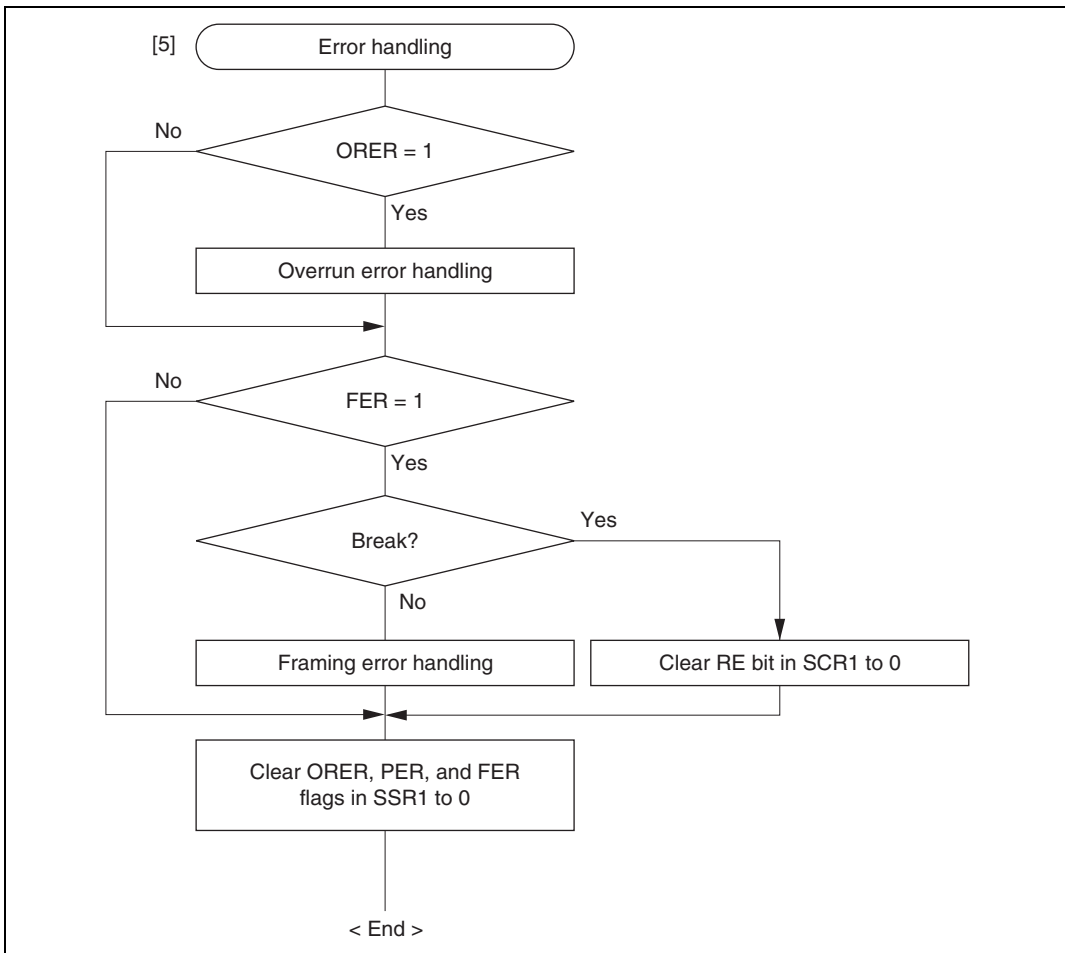


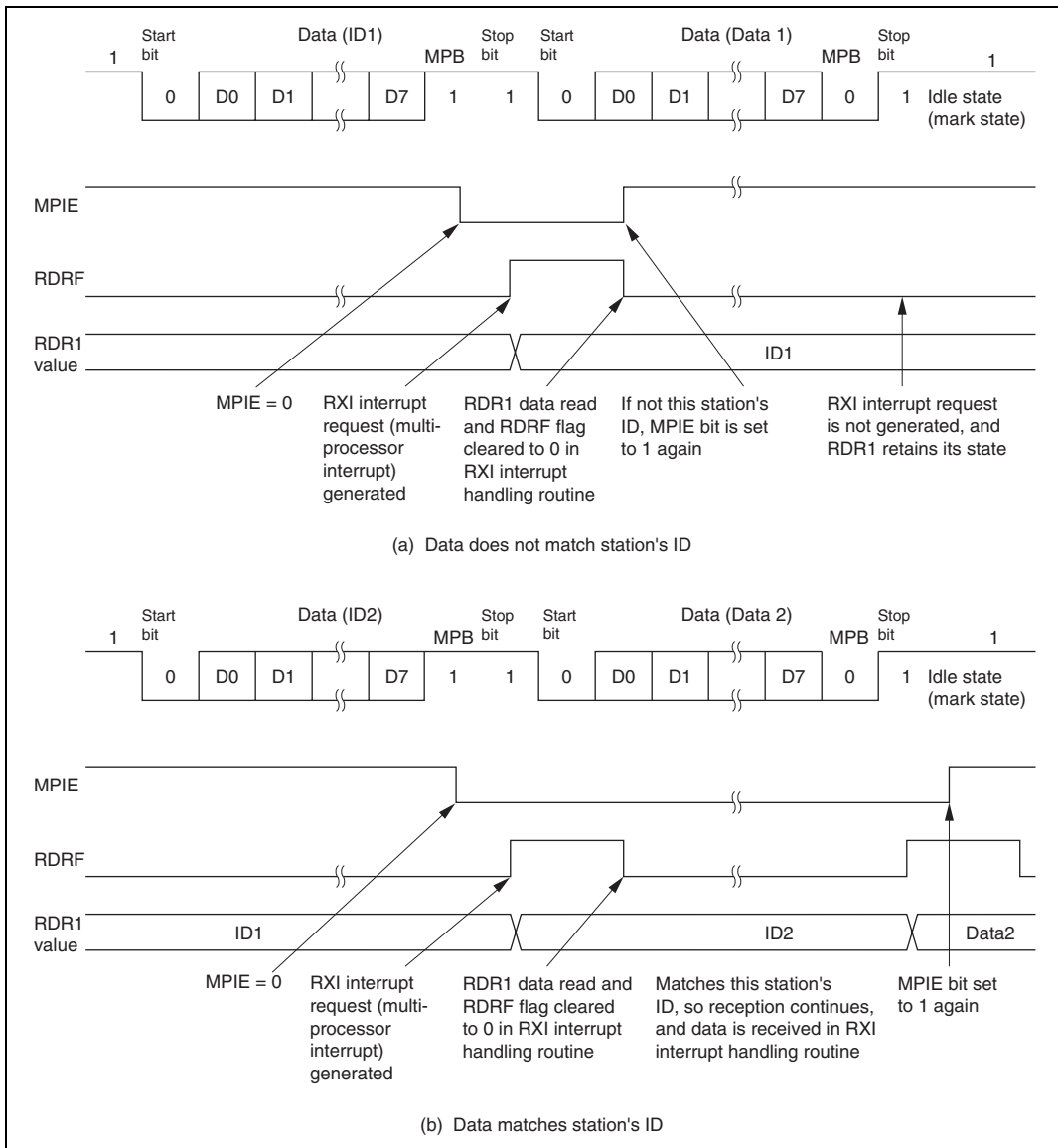
Figure 23.12 Sample Multiprocessor Serial Reception Flowchart (1)



**Figure 23.12 Sample Multiprocessor Serial Reception Flowchart (2)**

Figure 23.13 shows an example of SCI1 operation for multiprocessor format reception.





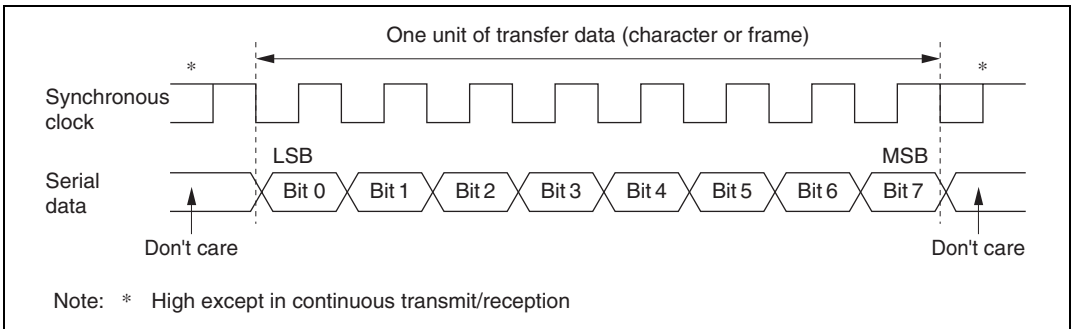
**Figure 23.13 Example of SCI Operation in Reception  
(Example with 8-Bit Data, Multiprocessor Bit, One Stop Bit)**

### 23.3.4 Operation in Clock Synchronous Mode

In clock synchronous mode, data is transmitted or received in synchronization with clock pulses, making it suitable for high-speed serial communication.

Inside the SCI1, the transmitter and receiver are independent units, enabling full-duplex communication by use of a common clock. Both the transmitter and the receiver also have a double-buffered structure, so that data can be read or written during transmission or reception, enabling continuous data transfer.

Figure 23.14 shows the general format for clock synchronous serial communication.



**Figure 23.14 Data Format in Clock Synchronous Communication**

In clock synchronous serial communication, data on the transmission line is output from one falling edge of the serial clock to the next. Data is guaranteed valid at the rising edge of the serial clock.

In clock synchronous serial communication, one character consists of data output starting with the LSB and ending with the MSB. After the MSB is output, the transmission line holds the MSB state.

In clock synchronous mode, the SCI1 receives data in synchronization with the rising edge of the serial clock.

#### (1) Data Transfer Format

A fixed 8-bit data format is used.

No parity or multiprocessor bits are added.

#### (2) Clock

Either an internal clock generated by the built-in baud rate generator or an external serial clock input at the SCK1 pin can be selected, according to the setting of the  $C/\bar{A}$  bit in SMR1 and the CKE1 and CKE0 bits in SCR1. For details on SCI1 clock source selection, see table 23.9.

When the SCI1 is operated on an internal clock, the serial clock is output from the SCK1 pin.

Eight serial clock pulses are output in the transfer of one character, and when no transfer is performed the clock is fixed high. When only receive operations are performed, however, the serial clock is output until an overrun error occurs or the RE bit is cleared to 0. To perform receive operations in units of one character, select an external clock as the clock source.

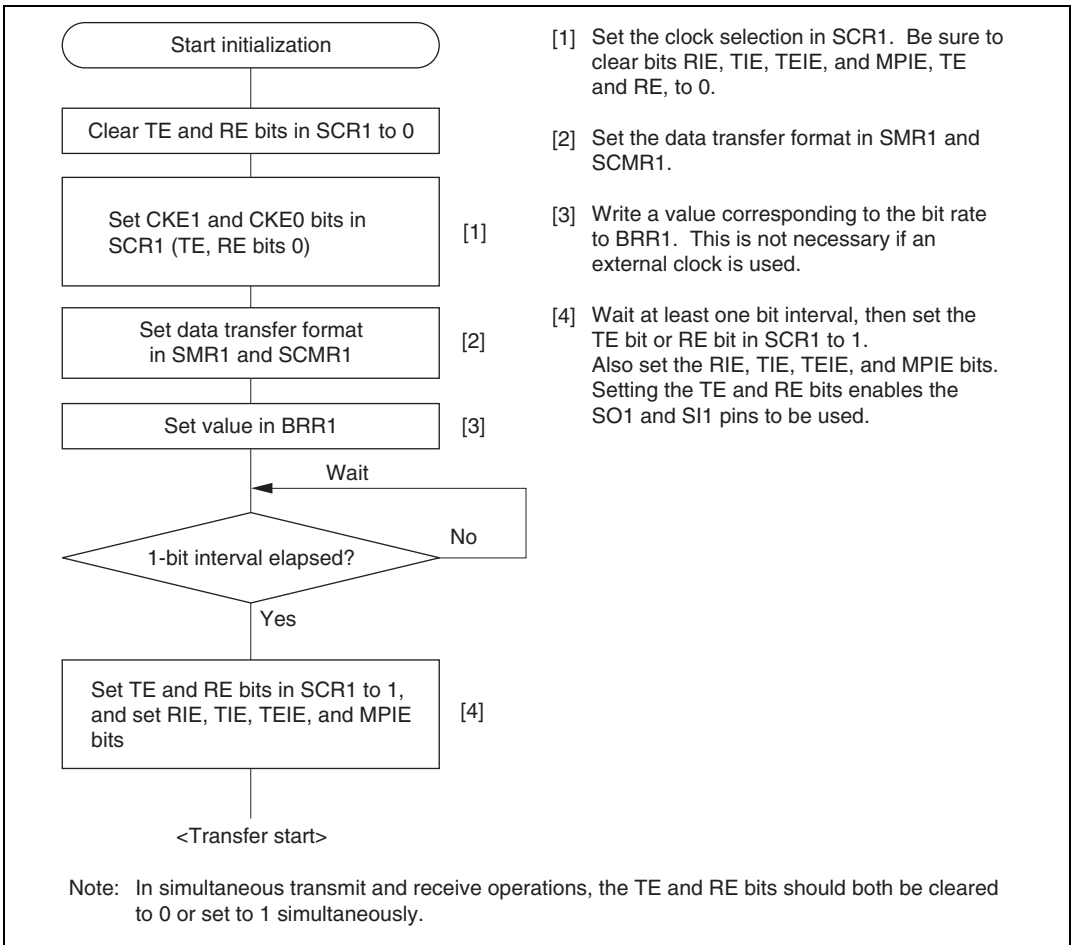
### (3) Data Transfer Operations

#### (a) SCI1 Initialization (Synchronous Mode)

Before transmitting and receiving data, first clear the TE and RE bits in SCR1 to 0, then initialize the SCI1 as described below.

When the operating mode, transfer format, etc., is changed, the TE and RE bits must be cleared to 0 before making the change using the following procedure. When the TE bit is cleared to 0, the TDRE flag is set to 1 and TSR is initialized. Note that clearing the RE bit to 0 does not change the settings of the RDRF, PER, FER, and ORER flags, or the contents of RDR1.

Figure 23.15 shows a sample SCI1 initialization flowchart.

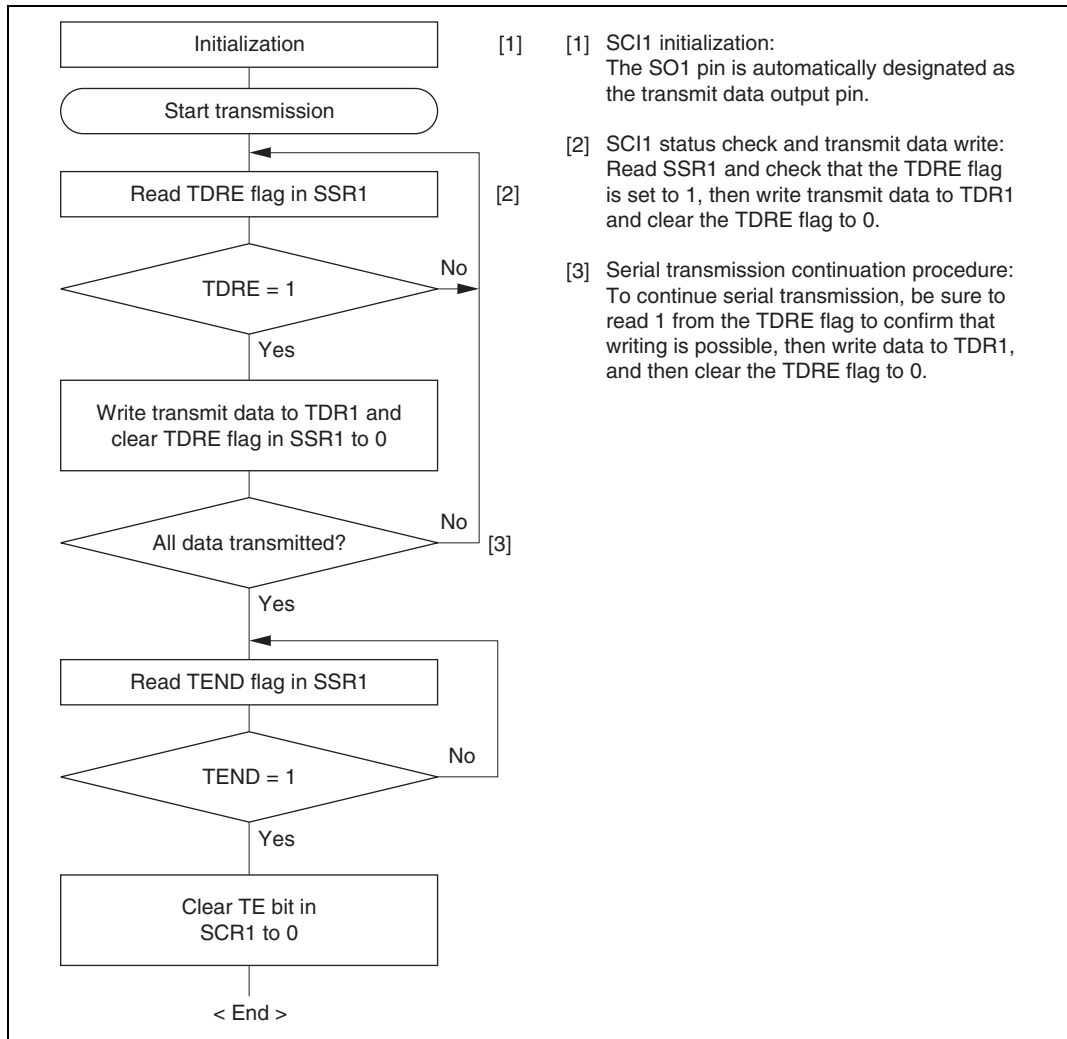


**Figure 23.15 Sample SCI Initialization Flowchart**

## (b) Serial Data Transmission (Clock Synchronous Mode)

Figure 23.16 shows a sample flowchart for serial transmission.

The following procedure should be used for serial data transmission.



**Figure 23.16 Sample Serial Transmission Flowchart**

In serial transmission, the SCI1 operates as described below.

[1] The SCI1 monitors the TDRE flag in SSR1, and if it is 0, recognizes that data has been written to TDR1, and transfers the data from TDR1 to TSR.

[2] After transferring data from TDR1 to TSR, the SCI1 sets the TDRE flag to 1 and starts transmission. If the TIE bit is set to 1 at this time, a transmit-data-empty interrupt (TXI) is generated.

When clock output mode has been set, the SCI1 outputs 8 serial clock pulses. When use of an external clock has been specified, data is output synchronized with the input clock.

The serial transmit data is sent from the SO1 pin starting with the LSB (bit 0) and ending with the MSB (bit 7).

[3] The SCI1 checks the TDRE flag at the timing for sending the MSB (bit 7).

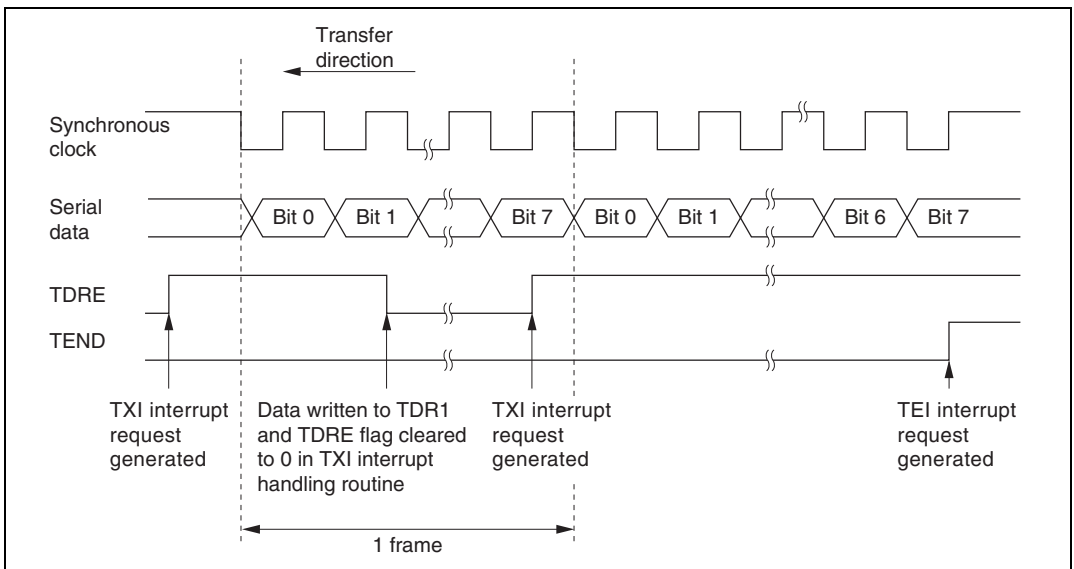
If the TDRE flag is cleared to 0, data is transferred from TDR1 to TSR, and serial transmission of the next frame is started.

If the TDRE flag is set to 1, the TEND flag in SSR1 is set to 1, the MSB (bit 7) is sent, and the SO1 pin maintains its state.

If the TEIE bit in SCR1 is set to 1 at this time, a transmit-end interrupt (TEI) request is generated.

[4] After completion of serial transmission, the SCK1 pin is held in a constant state.

Figure 23.17 shows an example of SCI1 operation in transmission.



**Figure 23.17 Example of SCI1 Operation in Transmission**

## (c) Serial Data Reception (Clock Synchronous Mode)

Figure 23.18 shows a sample flowchart for serial reception.

The following procedure should be used for serial data reception.

When changing the operating mode from asynchronous to synchronous, be sure to check that the ORER, PER, and FER flags are all cleared to 0.

The RDRF flag will not be set if the FER or PER flag is set to 1, and neither transmit nor receive operations will be possible.

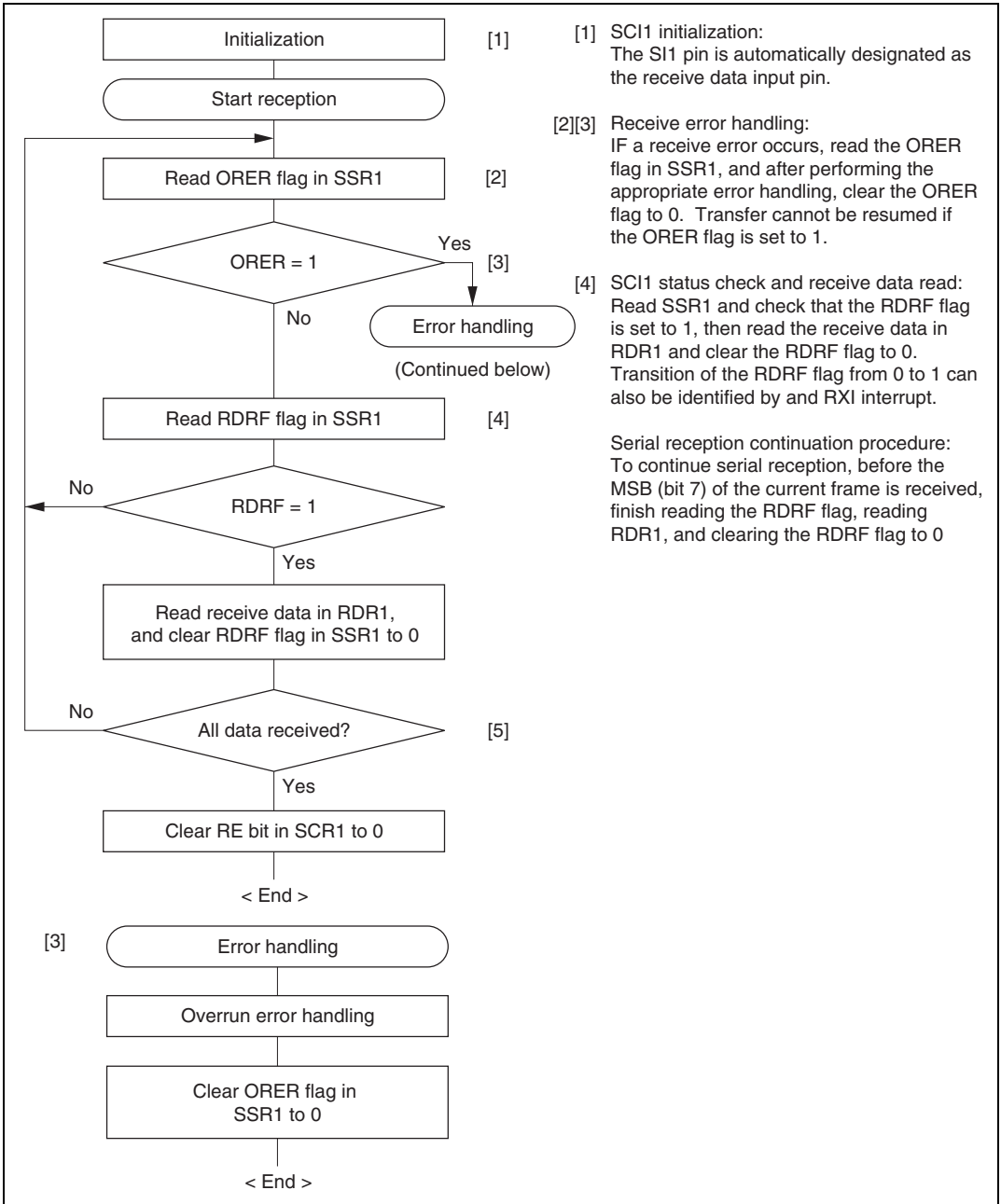


Figure 23.18 Sample Serial Reception Flowchart



In serial reception, the SCI1 operates as described below.

[1] The SCI1 performs internal initialization in synchronization with serial clock input or output.

[2] The received data is stored in RSR in LSB-to-MSB order.

After reception, the SCI1 checks whether the RDRF flag is 0 and the receive data can be transferred from RSR to RDR1.

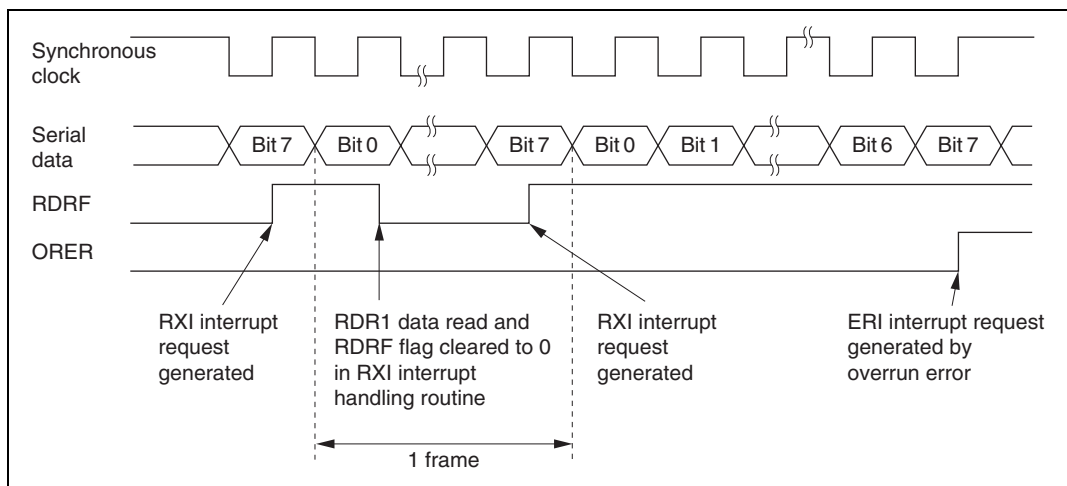
If this check is passed, the RDRF flag is set to 1, and the receive data is stored in RDR1. If a receive error is detected in the error check, the operation is as shown in table 23.11.

Neither transmit nor receive operations can be performed subsequently when a receive error has been found in the error check.

[3] If the RIE bit in SCR1 is set to 1 when the RDRF flag changes to 1, a receive-data-full interrupt (RXI) request is generated.

Also, if the RIE bit in SCR1 is set to 1 when the ORER flag changes to 1, a receive-error interrupt (ERI) request is generated.

Figure 23.19 shows an example of SCI1 operation in reception.

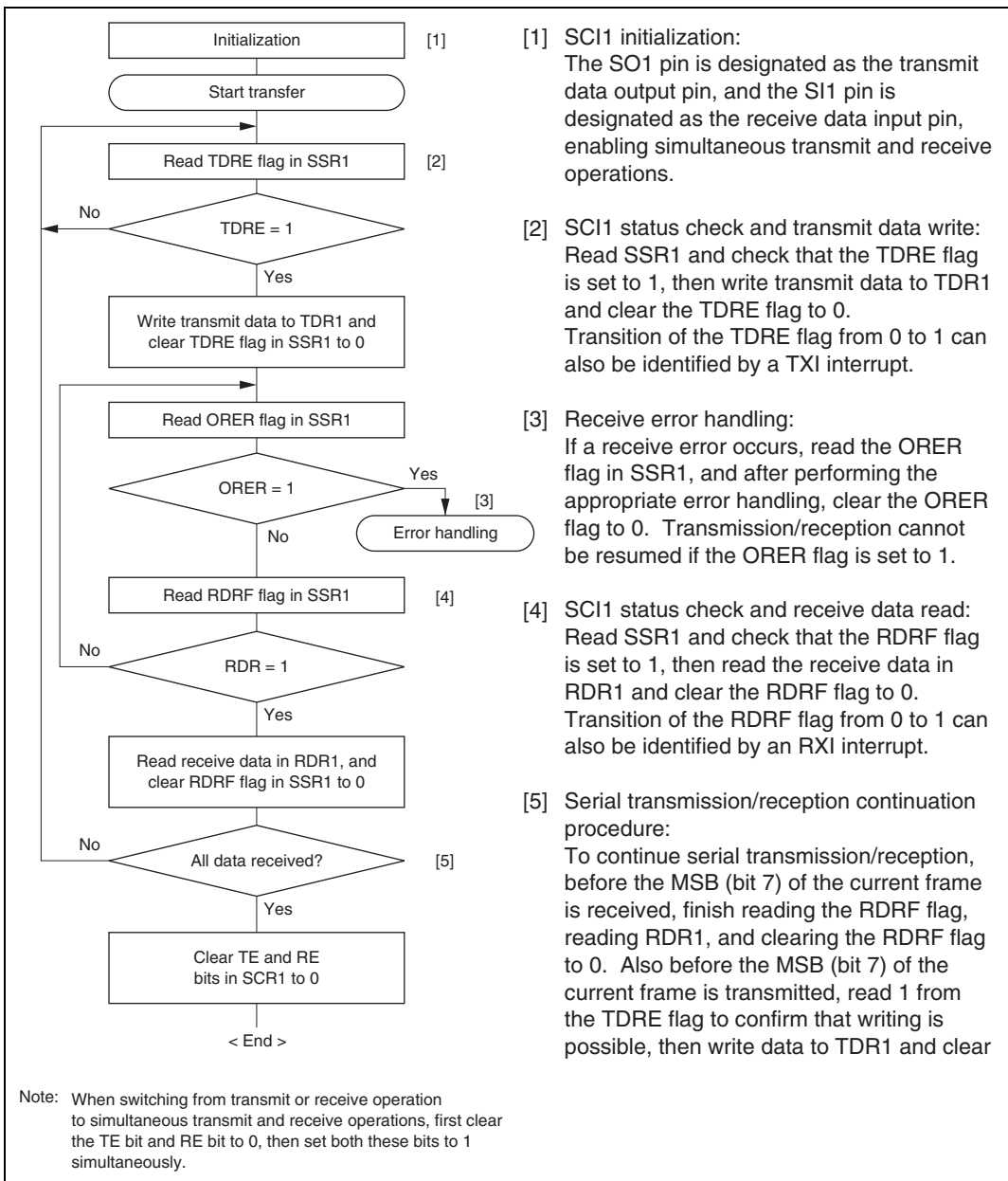


**Figure 23.19 Example of SCI1 Operation in Reception**

(d) Simultaneous Serial Data Transmission and Reception (Clock Synchronous Mode)

Figure 23.20 shows a sample flowchart for simultaneous serial transmit and receive operations.

The following procedure should be used for simultaneous serial data transmit and receive operations.



**Figure 23.20 Sample Flowchart of Simultaneous Serial Transmit and Receive Operations**

## 23.4 SCI1 Interrupts

The SCI1 has four interrupt sources: the transmit-end interrupt (TEI) request, receive-error interrupt (ERI) request, receive-data-full interrupt (RXI) request, and transmit-data-empty interrupt (TXI) request. Table 23.12 shows the interrupt sources and their relative priorities. Individual interrupt sources can be enabled or disabled with the TIE, RIE, and TEIE bits in SCR1. Each kind of interrupt request is sent to the interrupt controller independently. When the TDRE flag in SSR1 is set to 1, a TXI interrupt request is generated. When the TEND flag in SSR1 is set to 1, a TEI interrupt request is generated. When the RDRF flag in SSR1 is set to 1, an RXI interrupt request is generated. When the ORER, PER, or FER flag in SSR1 is set to 1, an ERI interrupt request is generated.

**Table 23.12 SCI1 Interrupt Sources**

Channel	Interrupt Source	Description	Priority*
1	ERI	Interrupt by receive error (ORER, FER, or PER)	High
	RXI	Interrupt by receive data register full (RDRF)	↑
	TXI	Interrupt by transmit data register empty (TDRE)	
	TEI	Interrupt by transmit end (TEND)	

The TEI interrupt is requested when the TEND flag is set to 1 while the TEIE bit is set to 1. The TEND flag is cleared at the same time as the TDRE flag. Consequently, if a TEI interrupt and a TXI interrupt are requested simultaneously, the TXI interrupt will have priority for acceptance, and the TDRE flag and TEND flag may be cleared. Note that the TEI interrupt will not be accepted in this case.

## 23.5 Usage Notes

The following points should be noted when using the SCI1.

### (1) Relation between Writes to TDR1 and the TDRE Flag

The TDRE flag in SSR1 is a status flag that indicates that transmit data has been transferred from TDR1 to TSR. When the SCI1 transfers data from TDR1 to TSR, the TDRE flag is set to 1.

Data can be written to TDR1 regardless of the state of the TDRE flag. However, if new data is written to TDR1 when the TDRE flag is cleared to 0, the data stored in TDR1 will be lost since it has not yet been transferred to TSR. It is therefore essential to check that the TDRE flag is set to 1 before writing transmit data to TDR1.

### (2) Operation when Multiple Receive Errors Occur Simultaneously

If a number of receive errors occur at the same time, the state of the status flags in SSR1 is as shown in table 23.13. If there is an overrun error, data is not transferred from RSR to RDR1, and the receive data is lost.

**Table 23.13 State of SSR1 Status Flags and Transfer of Receive Data**

SSR1 Status Flags				Receive Data Transfer	Receive Errors
RDRF	ORER	FER	PER	RSR → RDR1	
1	1	0	0	×	Overrun error
0	0	1	0	○	Framing error
0	0	0	1	○	Parity error
1	1	1	0	×	Overrun error + framing error
1	1	0	1	×	Overrun error + parity error
0	0	1	1	○	Framing error + parity error
1	1	1	1	×	Overrun error + framing error + parity error

Notes: ○: Receive data is transferred from RSR to RDR1.

×: Receive data is not transferred from RSR to RDR1.

### (3) Break Detection and Processing

When a framing error (FER) is detected, a break can be detected by reading the SI1 pin value directly. In a break, the input from the SI1 pin becomes all 0s, and so the FER flag is set, and the parity error flag (PER) may also be set.

Note that, since the SCI1 continues the receive operation after receiving a break, even if the FER flag is cleared to 0, it will be set to 1 again.

## (4) Sending a Break

The SO1 pin has a dual function as an I/O port whose direction (input or output) is determined by PDR and PCR. This feature can be used to send a break.

Between serial transmission initialization and setting of the TE bit to 1, the mark state is replaced by the value of PDR (the pin does not function as the SO1 pin until the TE bit is set to 1). Consequently, PCR and PDR for the port corresponding to the SO1 pin should first be set to 1.

To send a break during serial transmission, first clear PDR to 0, then clear the TE bit to 0.

When the TE bit is cleared to 0, the transmitter is initialized regardless of the current transmission state, the SO1 pin becomes an I/O port, and 0 is output from the SO1 pin.

## (5) Receive Error Flags and Transmit Operations (Clock Synchronous Mode Only)

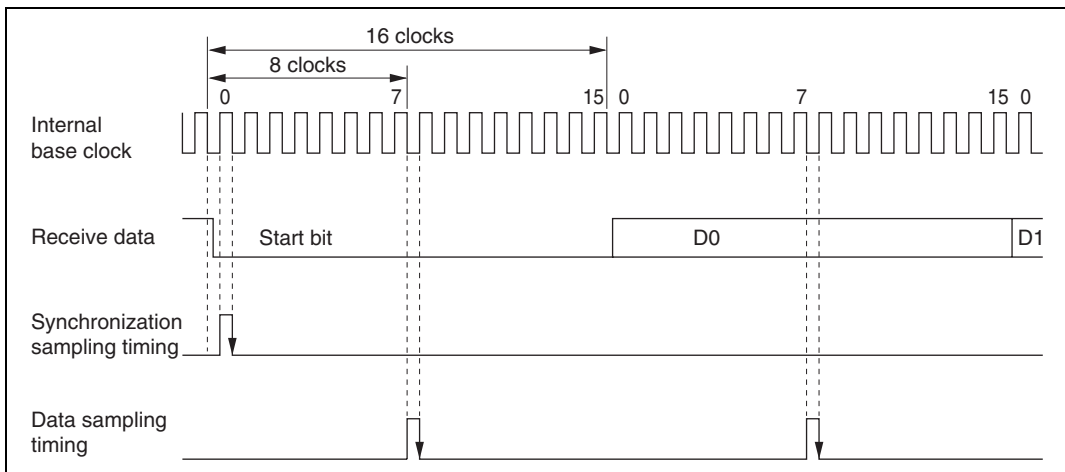
Transmission cannot be started when a receive error flag (ORER, PER, or FER) is set to 1, even if the TDRE flag is cleared to 0. Be sure to clear the receive error flags to 0 before starting transmission.

Note also that receive error flags cannot be cleared to 0 even if the RE bit is cleared to 0.

## (6) Receive Data Sampling Timing and Reception Margin in Asynchronous Mode

In asynchronous mode, the SCI1 operates on a base clock with a frequency of 16 times the transfer rate.

In reception, the SCI1 samples the falling edge of the start bit using the base clock, and performs internal synchronization. Receive data is latched internally at the rising edge of the 8th pulse of the base clock. This is illustrated in figure 23.21.



**Figure 23.21 Receive Data Sampling Timing in Asynchronous Mode**

Thus the receive margin in asynchronous mode is given by equation (1) below.

$$M = \left| \left( 0.5 - \frac{1}{2N} \right) - (L - 0.5) F - \frac{|D - 0.5|}{N} (1 + F) \right| \times 100\% \quad \dots(1)$$

Where M: Receive margin (%)

N: Ratio of bit rate to clock (N = 16)

D: Clock duty (D = 0 to 1.0)

L: Frame length (L = 9 to 12)

F: Absolute value of clock rate deviation

Assuming values of F = 0 and D = 0.5 in equation (1), a receive margin of 46.875% is given by equation (2) below.

When D = 0.5 and F = 0,

$$\begin{aligned} M &= \left( 0.5 - \frac{1}{2 \times 16} \right) \times 100\% \\ &= 46.875\% \quad \dots(2) \end{aligned}$$

However, this is only a theoretical value, and a margin of 20% to 30% should be allowed in system design.

## Section 24 Serial Communication Interface 2 (SCI2)

### 24.1 Overview

The serial communication interface 2 (SCI2) that has a 32-byte data buffer carries out clocked synchronous serial transmission of 32 bytes by a single operation.

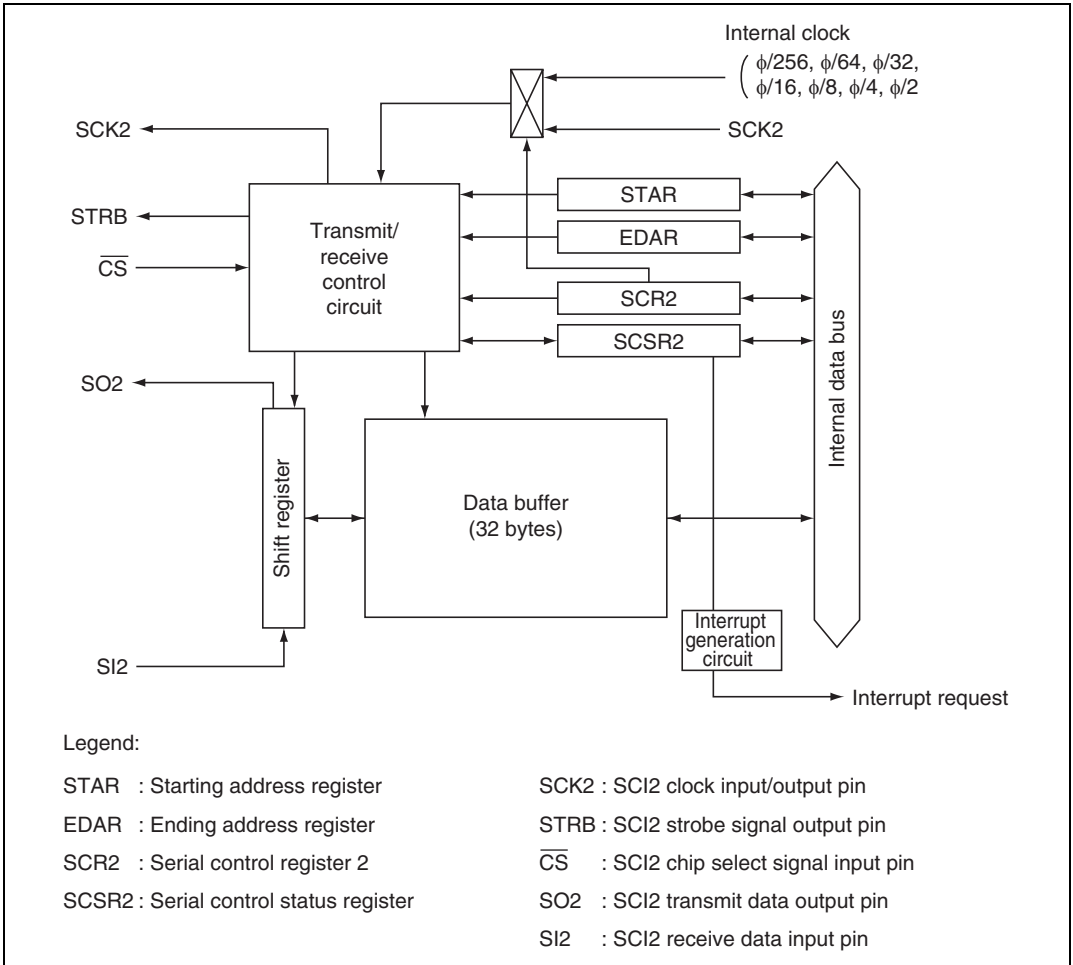
#### 24.1.1 Features

SCI2 features are listed below.

- 32 bytes data transfer can be automatically carried out
- Choice of 7 internal clocks ( $\phi/256$ ,  $\phi/64$ ,  $\phi/32$ ,  $\phi/16$ ,  $\phi/8$ ,  $\phi/4$ , and  $\phi/2$ ) and an external clock as serial clock source
- Interrupt occurs when transmission has been completed or an error has occurred
- Data transfer at intervals of 1 byte can be set  
Data transfer can be carried out at intervals of 1 byte. The interval can be selected from a multiple of internal clock cycle by 56, 24, or 8 times
- Start of data transfer can be controlled by input of chip select
- Strobe pulse is output for each 1-byte transfer

### 24.1.2 Block Diagram

Figure 24.1 shows a block diagram of the SCI2.



**Figure 24.1 Block Diagram of SCI2**



### 24.1.3 Pin Configuration

Table 24.1 shows pin configuration of the SCI2.

**Table 24.1 Pin Configuration**

Name	Abbrev.	I/O	Function
SCI2 Clock	SCK2	I/O	SCI2 clock input/output pin
SCI2 Data input	SI2	Input	SCI2 receive data input pin
SCI2 Data output	SO2	Output	SCI2 transmit data output pin
SCI2 Strobe	STRB	Output	SCI2 strobe signal output pin
SCI2 Chip select	$\overline{\text{CS}}$	Input	SCI2 chip select signal input pin

### 24.1.4 Register Configuration

Table 24.2 shows register configuration of the SCI2.

**Table 24.2 Register Configuration**

Name	Abbrev.	R/W	Initial Value	Address*
Starting address register	STAR	R/W	H'E0	H'D0E0
Ending address register	EDAR	R/W	H'E0	H'D0E1
Serial control register 2	SCR2	R/W	H'20	H'D0E2
Serial control status register 2	SCSR2	R/W	H'60	H'D0E3
Serial data buffer (32 bytes)	—	R/W	Undefined	H'D0C0 to H'D0DF

Note: \* Lower 16 bits of the address.

## 24.2 Register Descriptions

### 24.2.1 Starting Address Register (STAR)

Bit :	7	6	5	4	3	2	1	0
	—	—	—	STA4	STA3	STA2	STA1	STA0
Initial value :	1	1	1	0	0	0	0	0
R/W :	—	—	—	R/W	R/W	R/W	R/W	R/W

The STAR is a readable/writable register that specifies the transfer starting address within the address space (H'FFD0C0 to H'FFD0DF) to which a 32-byte data buffer is assigned. The 5 low-order bits of the STAR correspond to the 5 low-order bits of the address of 32-byte buffer. The range for executing continuous data transfer on STAR and EDAR is specified. When the value of STAR is equal to that of EDAR, only one-byte transfer is carried out.

Since the 7 to 5 bits of the STAR are reserved, writes are disabled. When each bit is read, 1 is read at all times.

The STAR is initialized to H'E0 by a reset.

### 24.2.2 Ending Address Register (EDAR)

Bit :	7	6	5	4	3	2	1	0
	—	—	—	EDA4	EDA3	EDA2	EDA1	EDA0
Initial value :	1	1	1	0	0	0	0	0
R/W :	—	—	—	R/W	R/W	R/W	R/W	R/W

The EDAR is a readable/writable register that specifies the transfer ending address within the address space (H'FFD0C0 to H'FFD0DF) to which 32-byte data buffer is assigned. The 5 low-order bits of EDAR correspond to the 5 low-order bits of the address of 32-byte buffer. The range for executing continuous data transfer is specified by the EDAR and the STAR. If the value of the STAR is equal to that of the EDAR, only one-byte transfer is carried out.

Since the 7 to 5 bits of the EDAR are reserved, writes are disabled. When each bit is read, 1 is read at all times.

The EDAR is initialized to H'E0 by a reset.

### 24.2.3 Serial Control Register 2 (SCR2)

Bit :	7	6	5	4	3	2	1	0
	TEIE	ABTIE	—	GAP1	GAP0	CKS2	CKS1	CKS0
Initial value :	0	0	1	0	0	0	0	0
R/W :	R/W	R/W	—	R/W	R/W	R/W	R/W	R/W

The SCR 2 is a readable/writable register that enables or disables generation of SCI2 interrupt and selects an data transfer interval and transfer clock when an internal clock is used.

The SCR2 is initialized to H'20 by a reset.

**Bit 7—Transmit End Interrupt Enable (TEIE):** Enables or disables the occurrence of transmit-end interrupt when data transfer has been completed and TEI of the SCR2 has been set to 1.

#### Bit 7

TEIE	Description
0	Transmit-end interrupt disabled (Initial value)
1	Transmit-end interrupt enabled

**Bit 6—Transmit Cutoff Interrupt (ABTIE):** Enables or disables the occurrence of transmit-cutoff interrupt when the  $\overline{CS}$  pin has entered a high level during transmission and ABT of the SCRS2 has been set to 1.

#### Bit 6

ABTIE	Description
0	Transmit-cutoff interrupt disabled (Initial value)
1	Transmit-cutoff interrupt enabled

**Bit 5—Reserved:** When read, 1 is read at all times. Writes are disabled.

**Bits 4 and 3—Transmit Data Interval Select 1 and 0 (GAP1, GAP0):** When an internal clock is used, data can be transmitted at 1-byte intervals. During that time, the SCK2 pin retains the high level. When data is transmitted without intervals, the STRB signal retains the low level.

Bit 4	Bit 3	Description
GAP1	GAP0	
0	0	Data transmission without intervals (Initial value)
0	1	Data intervals: 8 clocks
1	0	Data intervals: 24 clocks
1	1	Data intervals: 56 clocks

**Bits 2 to 0—Transfer Clock Select 2 to 0 (CKS2 to CKS0):** Selects transfer clock.

Bit 2	Bit 1	Bit 0	SCK2 Pin	Clock Source	Prescaler Division Ratio	Transfer Clock Cycle	
CKS2	CKS1	CKS0				$\phi = 10 \text{ MHz}$	$\phi = 5 \text{ MHz}$
0	0	0	SCK2 output	Prescaler S	$\phi/256$ (Initial value)	25.6 $\mu\text{s}$	51.2 $\mu\text{s}$
0	0	1			$\phi/64$	6.4 $\mu\text{s}$	12.8 $\mu\text{s}$
0	1	0			$\phi/32$	3.2 $\mu\text{s}$	6.4 $\mu\text{s}$
0	1	1			$\phi/16$	1.6 $\mu\text{s}$	3.2 $\mu\text{s}$
1	0	0			$\phi/8$	0.8 $\mu\text{s}$	1.6 $\mu\text{s}$
1	0	1			$\phi/4$	0.4 $\mu\text{s}$	0.8 $\mu\text{s}$
1	1	0			$\phi/2$	—	0.4 $\mu\text{s}$
1	1	1	SCK2 input	External clock	—	—	—

### 24.2.4 Serial Control Status Register 2 (SCSR2)

Bit :	7	6	5	4	3	2	1	0
	TEI	—	—	SOL	ORER	WT	ABT	STF
Initial value :	0	1	1	0	0	0	0	0
R/W :	R/(W)*	—	—	R/W	R/(W)*	R/(W)*	R/(W)*	R/W

Note: \* Only 0 can be written to clear the flag.

The SCSR2 is an 8-bit register that indicates the SCI2's state of operation and error.

The SCSR2 is initialized to H'60 by a reset.

**Bit 7—Transmit End Interrupt Request Flag (TEI):** Indicates that data transmission or reception has been completed.

#### Bit 7

TEI	Description
0	[Clearing condition] (Initial value) When 0 is written after reading 1
1	[Setting condition] When transmission or reception has been completed

**Bits 6 and 5—Reserved:** When each bit is read, 1 is read at all times. Writes are disabled.

**Bit 4—Extension Data Bit (SOL):** The SOL sets the output level of the SO2 pin. When read, the output level of the SO2 pin is read. Output of the SO2 pin after completion of transmission retains the value of final bit of transfer data, but the output level of the SO2 pin can be changed by operating this bit before or after transmission. However, setting of the SOL bit becomes invalid when the next transmission is started. Therefore, if the output level of the SO2 pin is changed after completion of transmission, write operation for SOL must be performed every time when transmission is terminated. Since writing to this register during data transfer may cause malfunction, write operation must not be performed during transmission.

#### Bit 4

SOL	Description
0	Read The SO2 pin output is at a low level (Initial value)
	Write The SO2 pin output is changed to a low level
1	Read The SO2 pin output is at a high level
	Write The SO2 pin output is changed to a high level

**Bit 3—Overrun Error Flag (ORER):** The ORER indicates an occurrence of overrun error while an external clock is used. When excessive pulses are overlapped with the normal transfer clock caused by external noise, etc. during transmission, this bit is set to 1. At this time data transfer cannot be assured. When a clock is input after completion of transmission, it is also found to be in the state of overrun and this bit is set to 1. However, overrun is not detected when the  $\overline{CS}$  pin is at a high level.

**Bit 3**

<b>ORER</b>	<b>Description</b>
0	[Clearing condition] (Initial value) When 0 is written after reading 1
1	[Setting condition] When excessive pulses are overlapped with a normal transfer clock while an external clock is used, or when a clock is input after completion of transmission

**Bit 2—Wait Flag (WT):** The WT indicates that read/ or write to serial data buffer (32 bytes) has been executed during transmission and in the  $\overline{CS}$  input standby mode. The instruction at that time is ignored and this bit is set to 1.

**Bit 2**

<b>WT</b>	<b>Description</b>
0	[Clearing condition] (Initial value) When 0 is written after reading 1
1	[Setting condition] When an instruction to read/write to serial data buffer (32 bits) is directed during transmission and in the $\overline{CS}$ input standby mode

**Bit 1—Abort Flag (ABT):** The ABT indicates that the  $\overline{CS}$  pin has entered a high level during transmission. When a high level of the  $\overline{CS}$  pin is detected during transfer, the transfer is immediately cut off, and this bit is set to 1, and then the SCK2 and SO2 pins go into the high impedance state. At this time values of internal registers other than SCSR2 and serial data buffer (32 bytes) are retained. Transfer cannot be carried out while this bit is set to 1. Resume transfer after clearing to 0.

**Bit 1**

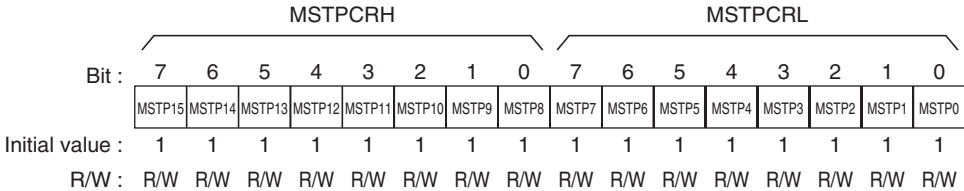
ABT	Description
0	[Clearing condition] (Initial value) When 0 is written after reading 1
1	[Setting condition] During transfer and when $\overline{CS}$ pin has entered a high level

**Bit 0—Start Flag (STF):** The STF controls the start of transfer operations. When this bit is set to 1 and PMR30 of PMR3 is 0, transfer operation of the SCI2 is started. When PMR30 of PMR3 is 1, the low level of the  $\overline{CS}$  pin is detected and transfer is started. This bit retains 1 during transfer and in the  $\overline{CS}$  input standby mode, and it is cleared to 0 after completion of transfer and when transfer is cut off by the  $\overline{CS}$  pin. Therefore, this bit can be used as a busy flag. When this bit is cleared to 0 during transfer, the transfer is cut off and the SCI2 is initialized. At this time the contents of internal registers other than the SCSR2 and the serial data buffer (32 bytes) are retained.

**Bit 0**

STF	Description
0	Read Transfer operations stops (Initial value)
	Write Transfer operation discontinues and the SCI2 is initialized
1	Read During transfer operation or in $\overline{CS}$ input standby mode
	Write Transfer operation starts

### 24.2.5 Module Stop Control Register (MSTPCR)



The MSTPCR, comprising two 8-bit readable/writable registers, performs module stop mode control. When the MSTPCR is set to 1, the SCI2 stops at the end of bus cycle and a transition is made to the module stop mode. For details, see section 4.5 Module Stop Mode.

The MSTPCR is initialized to H'FFFF by a reset.

**Bit 7—Module Stop (MSTP7):** Specifies the SCI2 module stop mode.

#### MSTPCRL

##### Bit 7

MSTP7	Description
0	SCI2 module stop mode is cleared
1	SCI2 module stop mode is set <span style="float: right;">(Initial value)</span>



## 24.3 Operation

The SCI2, comprising 32 bytes serial data buffer, can continuously transmit a maximum of 32 bytes data by a single operation, synchronized with clock pulse. Installation of a register enables to select transmit, receive, or simultaneous transmit/receive. When transmit is set, the value of serial data buffer is retained even after completion of transmission.

An internal or external clock can be selected as transfer clock. When an internal clock is selected, data can be transmitted at 1-byte intervals. The strobe signal can also be output from the STRB pin. When an external clock is selected, malfunction due to clock can be detected by the overrun flag.

The start of transfer and its forced cutoff can be controlled by  $\overline{CS}$  input. Forced cutoff can be detected by the abort flag.

### 24.3.1 Clock

Selection of a transfer clock can be made from seven internal clocks and an external clock. When an internal clock is selected, the SCK2 pin becomes a clock output pin.

### 24.3.2 Data Transfer Format

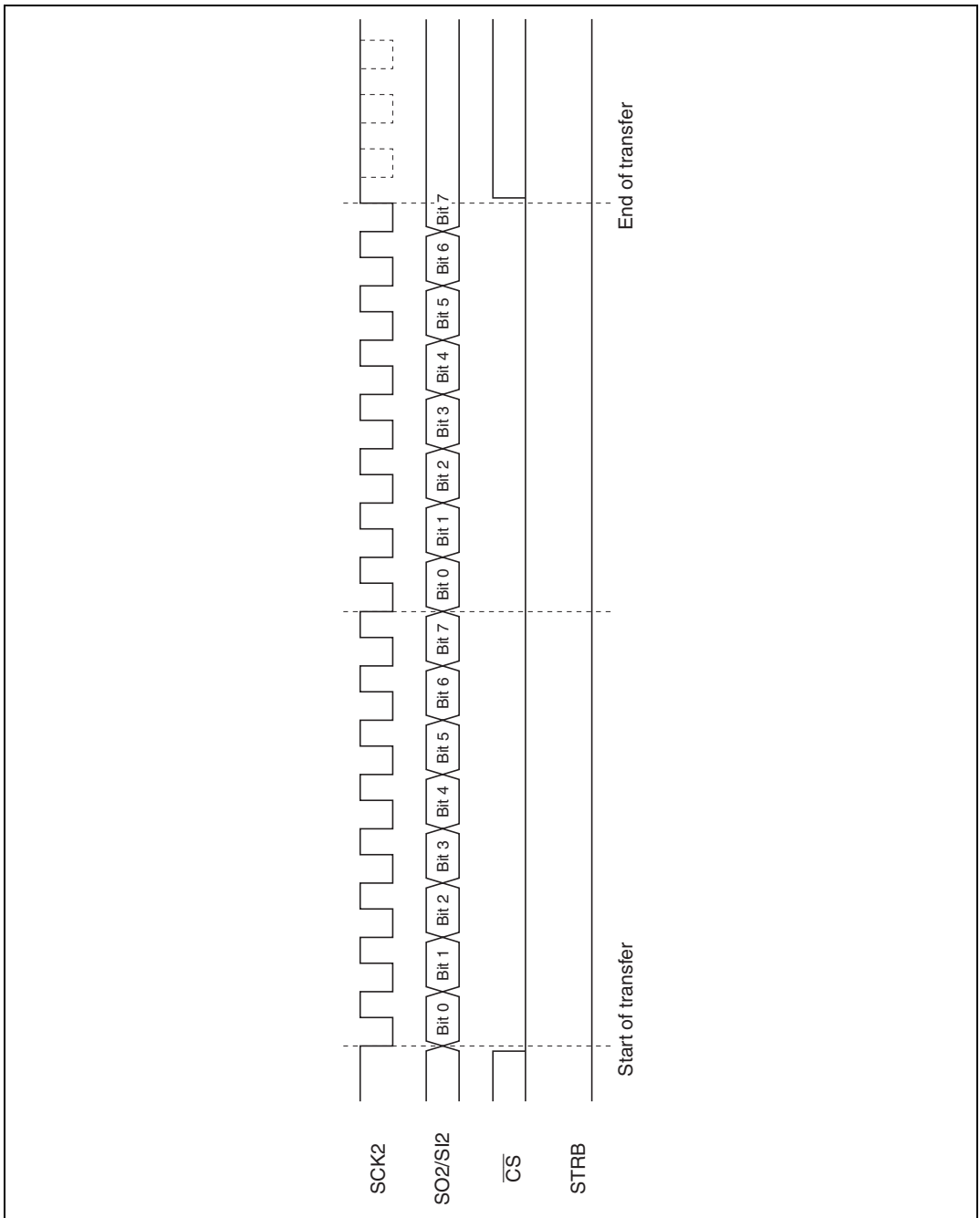
Figures 24.2 and 24.3 show transfer format of the SCI2.

LSB-first transfer that allows to transmit/receive from the lowest-order bit of data is performed.

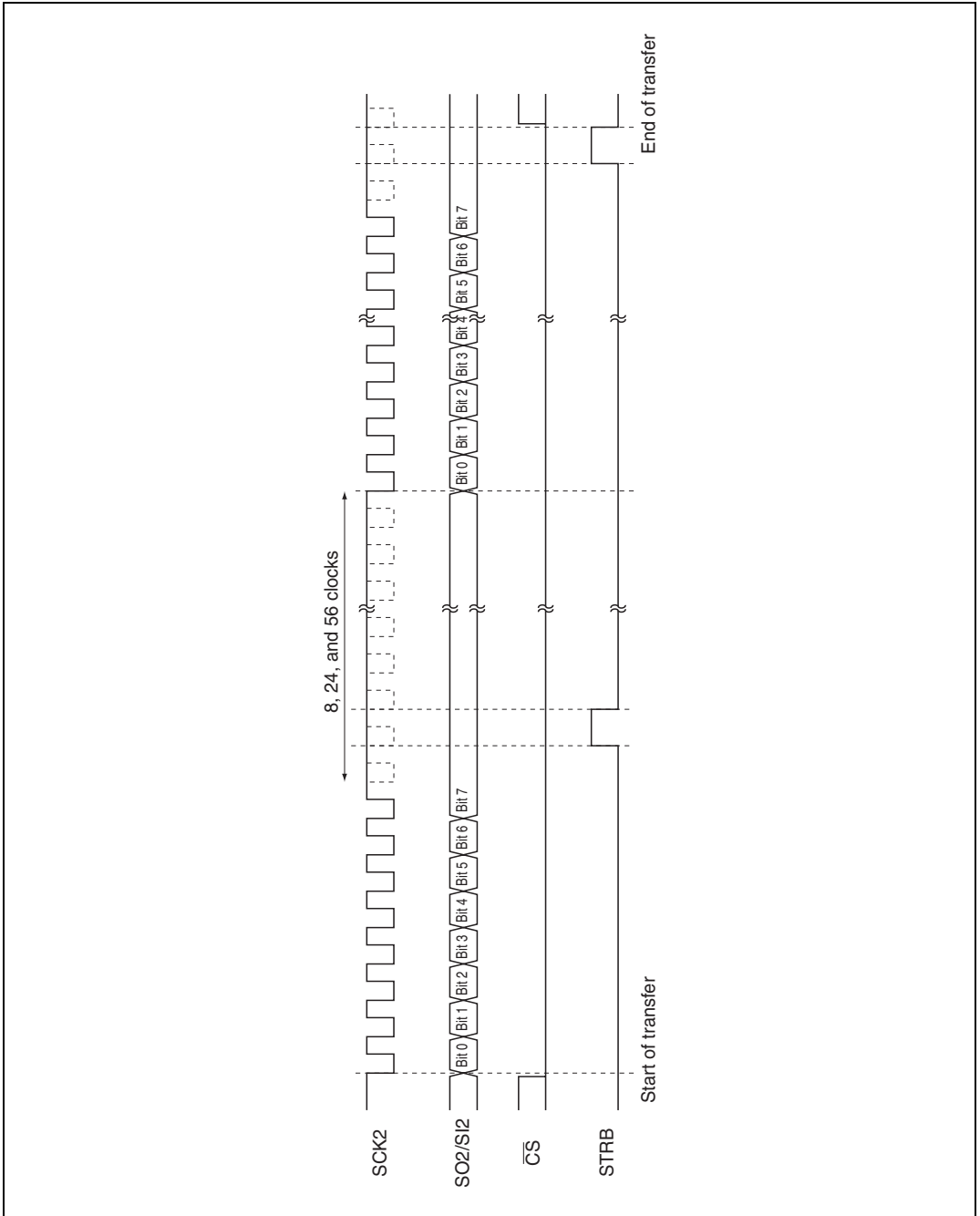
Transmit data is output from the fall of the transfer clock to its next fall. Receive data is collected at the rise of the transfer clock.

When an internal clock is selected as a transfer clock, data can be transferred at intervals of 1 byte. The SCK2 output is retained at a high level between transfer data. The strobe signal can be output from the STRB pin.

Selection of interval of transfer data is set at GAP1 or GAP0.



**Figure 24.2 Transfer Format (Transfer Data without Intervals)**



**Figure 24.3 Transfer Format (Transfer Data with Intervals)**

### 24.3.3 Data Transfer Operations

#### (1) SCI2 Initialization

To carry out data transfer, first initialize the SCI2 using software. Initialization is performed as described below:

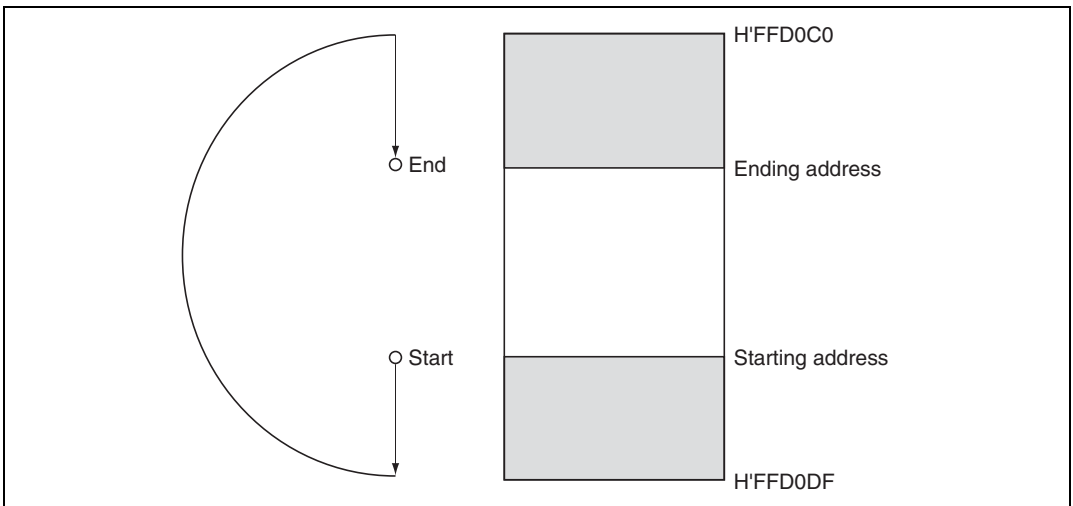
(1) Use PMR2, PMR3, STAR, EDAR, and SCR2 to set the pin and transmission mode while STF of SCSR2 is set to 0.

(2) The SCI2 pin is also used as a port. Switching of a port is performed on PMR3.

The SO2 pin allows to select CMOS output or NMOS open drain output on PMR2.

Transfer clock and transfer data intervals can be set on SCR2.

(3) The starting and ending addresses in the transfer data area are set on STAR and EDAR. If the value of the ending address is smaller than that of the starting address, transfer data at H'FFD0DF and then return to H'FFD0C0 so that transfer to the ending address can be carried out as shows in figure 24.4. If the value of the starting address is equal to that of the ending address is equal, perform one-byte transfer.



**Figure 24.4 If the Value of the Ending Address Is Smaller Than That of the Starting Address**

## (2) Transmit Operations

Transmit operations are performed as described below:

- (1) Set PMR26 and PMR27 of PMR2 to 1 and set them to the SO2 and SCK2 pins, respectively.  
Set the SO2 pin to the open drain output using PMR20 of PMR2 and set them to the  $\overline{CS}$  and STRB pins, respectively, using PMR30 and PMR31 of PMR3, as necessary.
- (2) Set the transfer clock and transfer data intervals (only when an internal clock is in operation) by setting SCR2.
- (3) Write transmit data to serial data buffer. In transmit operations, the contents of the data buffer will be retained even after the end of transmission. When the same data is transmitted again, it is not necessary to write data.
- (4) Set STAR to the 5 low-order bits at the transmission starting address and EDAR to the 5 low-order bits at the transmission ending address.
- (5) Set STF to 1. When PMR30 of PMR3 is set to 0, transmission is started by setting STF. While PMR30 of PMR3 is set to 1, transmission is started when low level of the  $\overline{CS}$  pin is detected.
- (6) After completion of transmission, TEI of SCSR2 is set to 1. STF is cleared to 0.

When an internal clock is selected, synchronous clock is output from the SCK2 pin at the time of starting transmission. When transmission has been completed, synchronous clock is not output until the next STF is set. During that time, the SO2 pin continues to output the value of final bit of the immediately preceding data.

When an external clock is selected, data is transmitted, synchronized with the clock input from the SCK2 pin. If the synchronous clock is continuously input after completion of transmission, no transmission is performed as the overrun state has been found and then ORER of the SCSR2 is set to 1. The SO2 pin continues to retain the value of final bit of the preceding data. However, if the  $\overline{CS}$  of PMR3 is set to 1, overrun is not detected when the  $\overline{CS}$  pin is at a high level.

The output value of the SO2 pin while transmission is being stopped can be changed by SOL of SCSR2. Data buffer cannot be read or written from CPU during transmission or in the  $\overline{CS}$  standby mode.

When a Read instruction has been executed, H'FF is read. Even if a Write instruction is executed, buffer does not change. When a Read/Write instruction has been executed during transmission or in the  $\overline{CS}$  input standby mode, WT of the SCSR2 is set.

While PMR30 of PMR3 is set to 1, transmission is immediately cut off when a high level of the  $\overline{CS}$  pin has been detected during transmission, and ABT is set to 1, and then STF is cleared to 0. The SCK2 and SO2 pins enter the high impedance state. Therefore, note that transmission may not be carried out while ABT is set to 1, and thus transmission must be resumed after clearing to 0.

### (3) Receive Operations

Receive operations are performed as described below:

- (1) Set PMR25 and PMR27 of PMR2 to 1 and set them to the SI2 and SCK2 pins, respectively. Set them to the  $\overline{CS}$  pin, using PMR30 of PMR3 as necessary.
- (2) Set the transfer clock and transfer data intervals (only when an internal clock is in operation) by setting SCR2.
- (3) Set STAR to 5 low-order bits at the receive starting address and EDAR to 5 low-order bits at the receive ending address. This enables to determine the area in the serial data buffer where receive data is stored.
- (4) Set STF to 1. When PMR30 of PMR3 is set to 0, reception is started by setting STF. While PMR30 of PMR3 is set to 1, reception is started when low level of the  $\overline{CS}$  pin is detected.
- (5) After completion of reception, TEI of SCSR2 is set to 1. STF is cleared to 0.
- (6) Read the receive data stored from the serial data buffer.

When an internal clock is selected, synchronous clock is output from the SCK2 pin at the time of starting reception. When reception has been completed, synchronous clock is not output until the next STF is set.

When an external clock is selected, data is received, synchronized with the clock input from the SCK2 pin. If the synchronous clock is continuously input after completion of reception, no reception is performed as the overrun state has been found and then ORER of the SCSR2 is set to 1. However, if the  $\overline{CS}$  of PMR3 is set to 1, overrun is not detected when the  $\overline{CS}$  pin is at a high level.

Data buffer cannot be read or written from CPU during reception or in the  $\overline{CS}$  standby mode.

When a Read instruction has been executed, H'FF is read. Even if a Write instruction is executed, buffer does not change. When a Read/Write instruction has been executed during reception or in the  $\overline{CS}$  input standby mode, WT of the SCSR2 is set.

While  $\overline{CS}$  of PMR3 is set to 1, transmission is immediately cut off when a high level of the  $\overline{CS}$  pin has been detected during transmission, and ABT is set to 1, and then STF is cleared to 0. The SCK2 and SO2 pins enter the high impedance state. Therefore, note that transmission may not be carried out while ABT is set to 1, and thus transmission must be resumed after clearing to 0.

## (4) Simultaneous Transmit/Receive Operations

Simultaneous transmit/receive operations are performed as described below:

- (1) Set PMR25, PMR26 and PMR27 of PMR2 to 1 and set them to the SI2, SO2 and SCK2 pins, respectively.  
Set the SO2 pin to open drain output, using PMR20 of PMR2, and set them to the  $\overline{CS}$  and STRB pins, respectively, using PMR30 and PMR31, as necessary.
- (2) Set the transfer clock and transfer data intervals (only when an internal clock is in operation) by setting SCR2.
- (3) Write transmit data to serial data buffer. In the simultaneous transmit/receive operations, the receive data is stored in the same address alternately with the transmit data.
- (4) Set STAR to 5 low-order bits at the transmission starting address and EDAR to 5 low-order bits at the transmission ending address.
- (5) Set STF to 1. When PMR30 of PMR3 is set to 0, transmission is started by setting STF. While PMR30 of PMR3 is set to 1, transmission is started when low level of the  $\overline{CS}$  pin is detected.
- (6) After completion of transmission, TEI of SCSR2 is set to 1. STF is cleared to 0.
- (7) Read the receive data stored from the serial data buffer.

When an internal clock is selected, synchronous clock is output from the SCK2 pin at the time of starting transmission. When transmission has been completed, synchronous clock is not output until the next STF is set. During that time, the SO2 pin continues to output the value of final bit of the preceding data.

When an external clock is selected, data is transmitted, synchronized with the clock input from the SCK2 pin. If the synchronous clock is continuously input after completion of transmission, no transmission is performed as the overrun state has been found and then ORE of the SCSR2 is set to 1. The SO2 pin continues to retain the value of final bit of the preceding data. However, if the CS of PMR3 is set to 1, overrun is not detected when the  $\overline{CS}$  pin is at a high level.

The output value of the SO2 pin while transmission is being stopped can be changed by SOL of SCSR2. Data buffer cannot be read or written from CPU during transmission or in the  $\overline{CS}$  standby mode. When a Read instruction has been executed, H'FF is read. Even if a Write instruction is executed, buffer does not change. When a Read/Write instruction has been executed during transmission or in the  $\overline{CS}$  input standby mode, WT of the SCSR2 is set.

While the CS of PMR3 is set to 1, transmission is immediately cut off when a high level of the  $\overline{CS}$  pin has been detected during transmission, and ABT is set to 1, and then STF is cleared to 0. The SCK2 and SO2 pins enter the high impedance state. Therefore, note that transmission may not be carried out while ABT is set to 1, and thus transmission must be resumed after clearing to 0.

## 24.4 Interrupt Sources

An interrupt source of the SCI2 is transmission cutoff by completion of transmission and the  $\overline{CS}$  pin, to which different vector addresses are assigned.

On completion of data transfer, TEI of SCSR2 is set to 1, and transfer-end interrupt request is generated. This interrupt can specify enable/disable by setting TEIE of SCR2.

While PMR30 of PMR3 is set to 1, transfer is cut off when the  $\overline{CS}$  pin enters a high level during data transfer, and ABT of SCSR2 is set to 1 and then transfer cutoff interrupt request is generated. This interrupt can specify enable/disable by setting ABTIE of SCR2. In the case of transfer cutoff by the  $\overline{CS}$  pin, overrun error, and read/write to serial data buffer during transfer and in the  $\overline{CS}$  standby mode, ABT, ORER, and WT of the SCSR2 is set to 1, respectively. These bits allow to determine error factors.



## Section 25 I<sup>2</sup>C Bus Interface (IIC)

### 25.1 Overview

The I<sup>2</sup>C bus interface conforms to and provides a subset of the Philips I<sup>2</sup>C bus (inter-IC bus) interface functions. The register configuration that controls the I<sup>2</sup>C bus differs partly from the Philips configuration, however.

Each I<sup>2</sup>C bus interface channel uses only one data line (SDA) and one clock line (SCL) to transfer data, saving board and connector space.

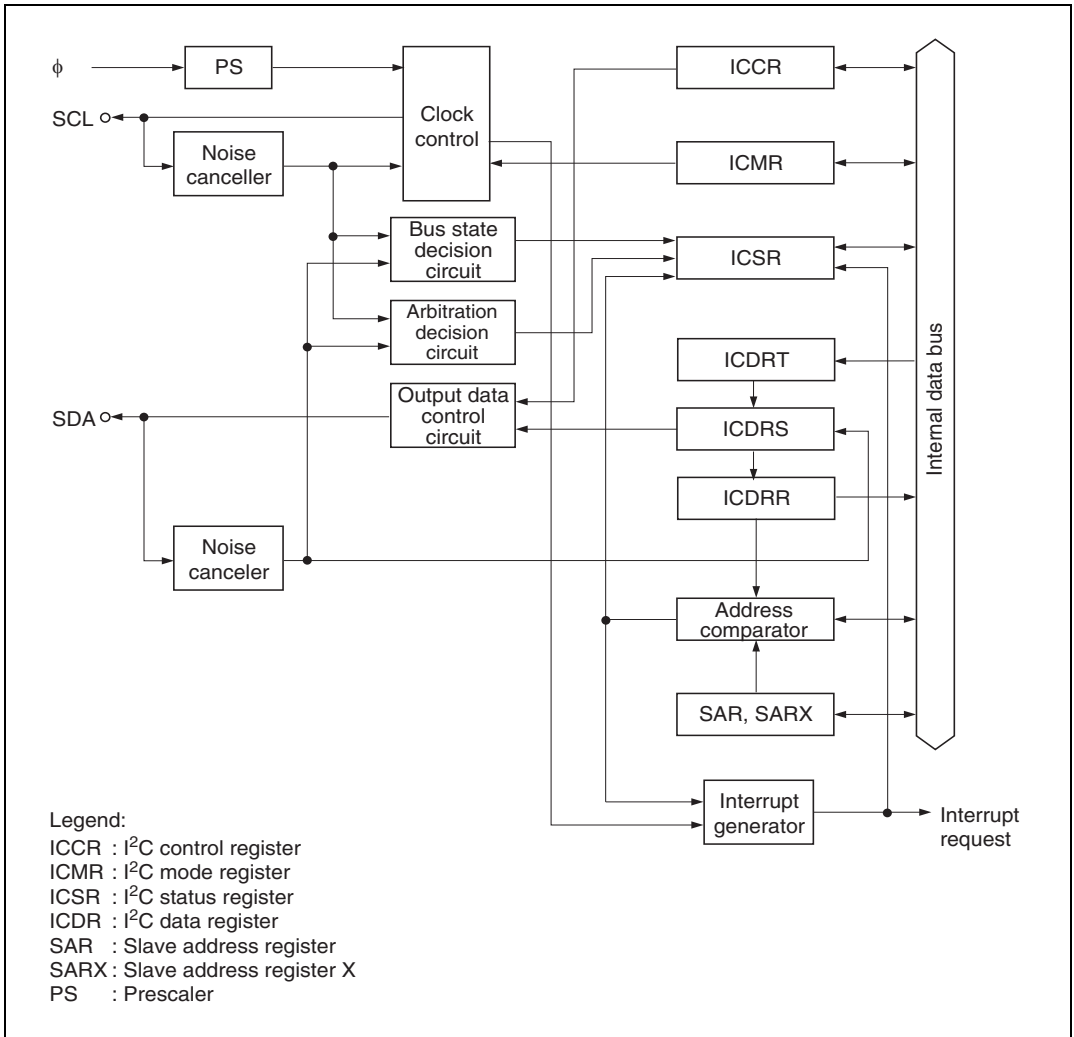
#### 25.1.1 Features

- Selection of addressing format or non-addressing format
  - I<sup>2</sup>C bus format: addressing format with acknowledge bit, for master/slave operation
  - Serial format: non-addressing format without acknowledge bit, for master operation only
- Conforms to Philips I<sup>2</sup>C bus interface (I<sup>2</sup>C bus format)
- Two ways of setting slave address (I<sup>2</sup>C bus format)
- Start and stop conditions generated automatically in master mode (I<sup>2</sup>C bus format)
- Selection of acknowledge output levels when receiving (I<sup>2</sup>C bus format)
- Automatic loading of acknowledge bit when transmitting (I<sup>2</sup>C bus format)
- Wait function in master mode (I<sup>2</sup>C bus format)
  - A wait can be inserted by driving the SCL pin low after data transfer, excluding acknowledgement. The wait can be cleared by clearing the interrupt flag.
- Wait function in slave mode (I<sup>2</sup>C bus format)
  - A wait request can be generated by driving the SCL pin low after data transfer, excluding acknowledgement. The wait request is cleared when the next transfer becomes possible.
- Three interrupt sources
  - Data transfer end (including transmission mode transition with I<sup>2</sup>C bus format and address reception after loss of master arbitration)
  - Address match: when any slave address matches or the general call address is received in slave receive mode (I<sup>2</sup>C bus format)
  - Stop condition detection
- Selection of 16 internal clocks (in master mode)
- Direct bus drive (with SCL and SDA pins)
  - Two pins-P24/SCL and P23/SDA- (normally CMOS pins) function as NMOS-only outputs when the bus drive function is selected.

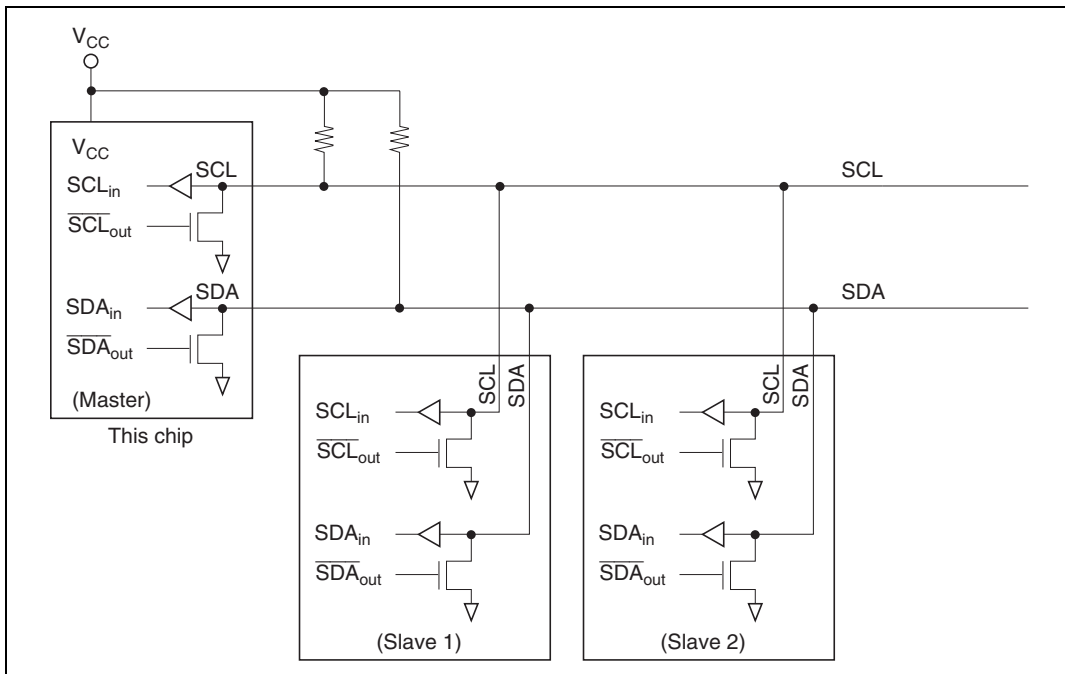
### 25.1.2 Block Diagram

Figure 25.1 shows a block diagram of the I<sup>2</sup>C bus interface.

Figure 25.2 shows an example of I/O pin connections to external circuits. I/O pins are driven only by NMOS and apparently function as NMOS open-drain outputs. However, applicable voltages to input pins depend on the power (V<sub>CC</sub>) voltage of this LSI.



**Figure 25.1 Block Diagram of I<sup>2</sup>C Bus Interface**



**Figure 25.2 I<sup>2</sup>C Bus Interface Connections (Example: This Chip as Master)**

### 25.1.3 Pin Configuration

Table 25.1 summarizes the input/output pins used by the I<sup>2</sup>C bus interface.

**Table 25.1 I<sup>2</sup>C Bus Interface Pins**

Name	Abbrev.	I/O	Function
Serial clock pin	SCL	I/O	IIC serial clock input/output
Serial data pin	SDA	I/O	IIC serial data input/output

### 25.1.4 Register Configuration

Table 25.2 summarizes the registers of the I<sup>2</sup>C bus interface.

**Table 25.2 Register Configuration**

Name	Abbrev.	R/W	Initial Value	Address <sup>*1</sup>
I <sup>2</sup> C bus control register	ICCR	R/W	H'01	H'D158
I <sup>2</sup> C bus status register	ICSR	R/W	H'00	H'D159
I <sup>2</sup> C bus data register	ICDR	R/W	—	H'D15E <sup>*2</sup>
I <sup>2</sup> C bus mode register	ICMR	R/W	H'00	H'D15F <sup>*2</sup>
Slave address register	SAR	R/W	H'00	H'D15F <sup>*2</sup>
Second slave address register	SARX	R/W	H'01	H'D15E <sup>*2</sup>
Serial/timer control register	STCR	R/W	H'00	H'FFEE
Module stop control register	MSTPCRH	R/W	H'FF	H'FFEC
	MSTPCRL	R/W	H'FF	H'FFED

Notes: 1. Lower 16 bits of the address.

2. The register that can be written or read depends on the ICE bit in the I<sup>2</sup>C bus control register. The slave address register can be accessed when ICE = 0, and the I<sup>2</sup>C bus mode register can be accessed when ICE = 1.

## 25.2 Register Descriptions

### 25.2.1 I<sup>2</sup>C Bus Data Register (ICDR)

Bit :	7	6	5	4	3	2	1	0
	ICDR7	ICDR6	ICDR5	ICDR4	ICDR3	ICDR2	ICDR1	ICDR0
Initial value :	—	—	—	—	—	—	—	—
R/W :	R/W	R/W	R/W	R/W	R/W	R/W	R/W	R/W

#### ICDRR

Bit :	7	6	5	4	3	2	1	0
	ICDRR7	ICDRR6	ICDRR5	ICDRR4	ICDRR3	ICDRR2	ICDRR1	ICDRR0
Initial value :	—	—	—	—	—	—	—	—
R/W :	R	R	R	R	R	R	R	R

#### ICDRS

Bit :	7	6	5	4	3	2	1	0
	ICDRS7	ICDRS6	ICDRS5	ICDRS4	ICDRS3	ICDRS2	ICDRS1	ICDRS0
Initial value :	—	—	—	—	—	—	—	—
R/W :	—	—	—	—	—	—	—	—

#### ICDRT

Bit :	7	6	5	4	3	2	1	0
	ICDRT7	ICDRT6	ICDRT5	ICDRT4	ICDRT3	ICDRT2	ICDRT1	ICDRT0
Initial value :	—	—	—	—	—	—	—	—
R/W :	W	W	W	W	W	W	W	W

#### TDRE, RDRF (Internal flag)

Bit :	—	—
	TDRE	RDRF
Initial value :	0	0
R/W :	—	—

ICDR is an 8-bit readable/writable register that is used as a transmit data register when transmitting and a receive data register when receiving. ICDR is divided internally into a shift register (ICDRS), receive buffer (ICDRR), and transmit buffer (ICDRT). ICDRS cannot be read or written by the CPU, ICDRR is read-only, and ICDRT is write-only. Data transfers among the three registers are performed automatically in coordination with changes in the bus state, and

affect the status of internal flags such as TDRE and RDRF.

After transmission/reception of one frame of data using ICDRS, if the I<sup>2</sup>C bus is in transmit mode and the next data is in ICDRT (the TDRE flag is 0), data is transferred automatically from ICDRT to ICDRS. After transmission/reception of one frame of data using ICDRS, if the I<sup>2</sup>C bus is in receive mode and no previous data remains in ICDRR (the RDRF flag is 0), data is transferred automatically from ICDRS to ICDRR.

If the number of bits in a frame, excluding the acknowledge bit, is less than 8, transmit data and receive data are stored differently. Transmit data should be written justified toward the MSB side when MLS = 0, and toward the LSB side when MLS = 1. Receive data bits read from the LSB side should be treated as valid when MLS = 0, and bits read from the MSB side when MLS = 1. ICDR is assigned to the same address as SARX, and can be written and read only when the ICE bit is set to 1 in ICCR.

The value of ICDR is undefined after a reset.

The TDRE and RDRF flags are set and cleared under the conditions shown below. Setting the TDRE and RDRF flags affects the status of the interrupt flags.

TDRE	Description
0	<p>The next transmit data is in ICDR (ICDRT), or transmission cannot be started [Clearing conditions] (Initial value)</p> <ol style="list-style-type: none"> <li>(1) When transmit data is written in ICDR (ICDRT) in transmit mode (TRS = 1)</li> <li>(2) When a stop condition is detected in the bus line state after a stop condition is issued with the I<sup>2</sup>C bus format or serial format selected</li> <li>(3) When a stop condition is detected with the I<sup>2</sup>C bus format selected</li> <li>(4) In receive mode (TRS = 0) (A 0 write to TRS during transfer is valid after reception of a frame containing an acknowledge bit)</li> </ol>
1	<p>The next transmit data can be written in ICDR (ICDRT) [Setting conditions]</p> <ol style="list-style-type: none"> <li>(1) In transmit mode (TRS = 1), when a start condition is detected in the bus line state after a start condition is issued in master mode with the I<sup>2</sup>C bus format or serial format selected</li> <li>(2) When data is transferred from ICDRT to ICDRS (Data transfer from ICDRT to ICDRS when TRS = 1 and TDRE = 0, and ICDRS is empty)</li> <li>(3) When a switch is made from receive mode (TRS = 0) to transmit mode (TRS = 1) after detection of a start condition</li> </ol>

RDRF	Description
0	The data in ICDR (ICDRR) is invalid (Initial value) [Clearing condition] When ICDR (ICDRR) receive data is read in receive mode
1	The ICDR (ICDRR) receive data can be read [Setting condition] When data is transferred from ICDRS to ICDRR (Data transfer from ICDRS to ICDRR in case of normal termination with TRS = 0 and RDRF = 0)

### 25.2.2 Slave Address Register (SAR)

Bit :	7	6	5	4	3	2	1	0
	SVA6	SVA5	SVA4	SVA3	SVA2	SVA1	SVA0	FS
Initial value :	0	0	0	0	0	0	0	0
R/W :	R/W	R/W	R/W	R/W	R/W	R/W	R/W	R/W

SAR is an 8-bit readable/writable register that stores the slave address and selects the communication format. When the chip is in slave mode (and the addressing format is selected), if the upper 7 bits of SAR match the upper 7 bits of the first frame received after a start condition, the chip operates as the slave device specified by the master device. SAR is assigned to the same address as ICMR, and can be written and read only when the ICE bit is cleared to 0 in ICCR. SAR is initialized to H'00 by a reset.

**Bits 7 to 1—Slave Address (SVA6 to SVA0):** Set a unique address in bits SVA6 to SVA0, differing from the addresses of other slave devices connected to the I<sup>2</sup>C bus.

**Bit 0—Format Select (FS):** Used together with the FSX bit in SARX to select the communication format.

- I<sup>2</sup>C bus format: addressing format with acknowledge bit
- Synchronous serial format: non-addressing format without acknowledge bit, for master mode only

The FS bit also specifies whether or not SAR slave address recognition is performed in slave mode.

SAR	SARX	
Bit 0	Bit 0	
FS	FSX	Operating Mode
0	0	I <sup>2</sup> C bus format <ul style="list-style-type: none"> <li>SAR and SARX slave addresses recognized</li> </ul>
	1	I <sup>2</sup> C bus format (Initial value) <ul style="list-style-type: none"> <li>SAR slave address recognized</li> <li>SARX slave address ignored</li> </ul>
1	0	I <sup>2</sup> C bus format <ul style="list-style-type: none"> <li>SAR slave address ignored</li> <li>SARX slave address recognized</li> </ul>
	1	Clock synchronous serial format <ul style="list-style-type: none"> <li>SAR and SARX slave addresses ignored</li> </ul>

### 25.2.3 Second Slave Address Register (SARX)

Bit :	7	6	5	4	3	2	1	0
	SVAX6	SVAX5	SVAX4	SVAX3	SVAX2	SVAX1	SVAX0	FSX
Initial value :	0	0	0	0	0	0	0	1
R/W :	R/W	R/W	R/W	R/W	R/W	R/W	R/W	R/W

SARX is an 8-bit readable/writable register that stores the second slave address and selects the communication format. When the chip is in slave mode (and the addressing format is selected), if the upper 7 bits of SARX match the upper 7 bits of the first frame received after a start condition, the chip operates as the slave device specified by the master device. SARX is assigned to the same address as ICDR, and can be written and read only when the ICE bit is cleared to 0 in ICCR. SARX is initialized to H'01 by a reset and in hardware standby mode.

**Bits 7 to 1—Second Slave Address (SVAX6 to SVAX0):** Set a unique address in bits SVAX6 to SVAX0, differing from the addresses of other slave devices connected to the I<sup>2</sup>C bus.



**Bit 0—Format Select X (FSX):** Used together with the FS bit in SAR to select the communication format.

- I<sup>2</sup>C bus format: addressing format with acknowledge bit
- Synchronous serial format: non-addressing format without acknowledge bit, for master mode only

The FSX bit also specifies whether or not SARX slave address recognition is performed in slave mode. For details, see the description of the FS bit in SAR.

### 25.2.4 I<sup>2</sup>C Bus Mode Register (ICMR)

Bit :	7	6	5	4	3	2	1	0
	MLS	WAIT	CKS2	CKS1	CKS0	BC2	BC1	BC0
Initial value :	0	0	0	0	0	0	0	0
R/W :	R/W	R/W	R/W	R/W	R/W	R/W	R/W	R/W

ICMR is an 8-bit readable/writable register that selects whether the MSB or LSB is transferred first, performs master mode wait control, and selects the master mode transfer clock frequency and the transfer bit count. ICMR is assigned to the same address as SAR. ICMR can be written and read only when the ICE bit is set to 1 in ICCR.

ICMR is initialized to H'00 by a reset.

**Bit 7—MSB-First/LSB-First Select (MLS):** Selects whether data is transferred MSB-first or LSB-first.

If the number of bits in a frame, excluding the acknowledge bit, is less than 8, transmit data and receive data are stored differently. Transmit data should be written justified toward the MSB side when MLS = 0, and toward the LSB side when MLS = 1. Receive data bits read from the LSB side should be treated as valid when MLS = 0, and bits read from the MSB side when MLS = 1. Do not set this bit to 1 when the I<sup>2</sup>C bus format is used.

#### Bit 7

MLS	Description
0	MSB-first (Initial value)
1	LSB-first

**Bit 6—Wait Insertion Bit (WAIT):** Selects whether to insert a wait between the transfer of data and the acknowledge bit, in master mode with the I<sup>2</sup>C bus format. When WAIT is set to 1, after the fall of the clock for the final data bit, the IRIC flag is set to 1 in ICCR, and a wait state begins (with SCL at the low level). When the IRIC flag is cleared to 0 in ICCR, the wait ends and the acknowledge bit is transferred. If WAIT is cleared to 0, data and acknowledge bits are transferred consecutively with no wait inserted.

The IRIC flag in ICCR is set to 1 on completion of the acknowledge bit transfer, regardless of the WAIT setting.

The setting of this bit is invalid in slave mode.

#### Bit 6

WAIT	Description
0	Data and acknowledge bits transferred consecutively (Initial value)
1	Wait inserted between data and acknowledge bits

---

**Bits 5 to 3—Transfer Clock Select (CKS2 to CKS0):** These bits, together with the IICX bit in the STCR register, select the serial clock frequency in master mode. They should be set according to the required transfer rate.

STCR				Transfer Rate			
Bit 6	Bit 5	Bit 4	Bit 3	Clock	$\phi = 5 \text{ MHz}$	$\phi = 8 \text{ MHz}$	$\phi = 10 \text{ MHz}$
IICX	CKS2	CKS1	CKS0		$\phi = 5 \text{ MHz}$	$\phi = 8 \text{ MHz}$	$\phi = 10 \text{ MHz}$
0	0	0	0	$\phi/28$	179 kHz	286 kHz	357 kHz
			1	$\phi/40$	125 kHz	200 kHz	250 kHz
		1	0	$\phi/48$	104 kHz	167 kHz	208 kHz
			1	$\phi/64$	78.1 kHz	125 kHz	156 kHz
	1	0	0	$\phi/80$	62.5 kHz	100 kHz	125 kHz
			1	$\phi/100$	50.0 kHz	80.0 kHz	100 kHz
		1	0	$\phi/112$	44.6 kHz	71.4 kHz	89.3 kHz
			1	$\phi/128$	39.1 kHz	62.5 kHz	78.1 kHz
1	0	0	0	$\phi/56$	89.3 kHz	143 kHz	179 kHz
			1	$\phi/80$	62.5 kHz	100 kHz	125 kHz
		1	0	$\phi/96$	52.1 kHz	83.3 kHz	104 kHz
			1	$\phi/128$	39.1 kHz	62.5 kHz	78.1 kHz
	1	0	0	$\phi/160$	31.3 kHz	50.0 kHz	62.5 kHz
			1	$\phi/200$	25.0 kHz	40.0 kHz	50.0 kHz
		1	0	$\phi/224$	22.3 kHz	35.7 kHz	44.6 kHz
			1	$\phi/256$	19.5 kHz	31.3 kHz	39.1 kHz

**Bits 2 to 0—Bit Counter (BC2 to BC0):** Bits BC2 to BC0 specify the number of bits to be transferred next. With the I<sup>2</sup>C bus format (when the FS bit in SAR or the FSX bit in SARX is 0), the data is transferred with one additional acknowledge bit. Bit BC2 to BC0 settings should be made during an interval between transfer frames. If bits BC2 to BC0 are set to a value other than 000, the setting should be made while the SCL line is low.

The bit counter is initialized to 000 by a reset and when a start condition is detected. The value returns to 000 at the end of a data transfer, including the acknowledge bit.

Bit 2	Bit 1	Bit 0	Bits/Frame	
BC2	BC1	BC0	Synchronous Serial Format	I <sup>2</sup> C Bus Format
0	0	0	8	9 (Initial value)
		1	1	2
	1	0	2	3
		1	3	4
1	0	0	4	5
		1	5	6
	1	0	6	7
		1	7	8

### 25.2.5 I<sup>2</sup>C Bus Control Register (ICCR)

Bit :	7	6	5	4	3	2	1	0
	ICE	IEIC	MST	TRS	ACKE	BBSY	IRIC	SCP
Initial value :	0	0	0	0	0	0	0	1
R/W :	R/W	R/W	R/W	R/W	R/W	R/W	R/(W)*	W

Note: \* Only 0 can be written to clear the flag.

ICCR is an 8-bit readable/writable register that enables or disables the I<sup>2</sup>C bus interface, enables or disables interrupts, selects master or slave mode and transmission or reception, enables or disables acknowledgement, confirms the I<sup>2</sup>C bus interface bus status, issues start/stop conditions, and performs interrupt flag confirmation.

ICCR is initialized to H'01 by a reset.

**Bit 7—I<sup>2</sup>C Bus Interface Enable (ICE):** Selects whether or not the I<sup>2</sup>C bus interface is to be used. When ICE is set to 1, port pins function as SCL and SDA input/output pins and transfer operations are enabled. When ICE is cleared to 0, the I<sup>2</sup>C bus interface module is disabled, and the internal state is initialized.

The SAR and SARX registers can be accessed when ICE is 0. The ICMR and ICDR registers can be accessed when ICE is 1.

#### Bit 7

ICE	Description
0	I <sup>2</sup> C bus interface module disabled, with SCL and SDA signal pins set to port function SAR and SARX can be accessed. The internal state of the I <sup>2</sup> C bus interface module is initialized. (Initial value)
1	I <sup>2</sup> C bus interface module enabled for transfer operations (pins SCL and SDA are driving the bus) ICMR and ICDR can be accessed

**Bit 6—I<sup>2</sup>C Bus Interface Interrupt Enable (IEIC):** Enables or disables interrupts from the I<sup>2</sup>C bus interface to the CPU.

#### Bit 6

IEIC	Description
0	Interrupts disabled (Initial value)
1	Interrupts enabled

**Bit 5—Master/Slave Select (MST)****Bit 4—Transmit/Receive Select (TRS)**

MST selects whether the I<sup>2</sup>C bus interface operates in master mode or slave mode.

TRS selects whether the I<sup>2</sup>C bus interface operates in transmit mode or receive mode.

In master mode with the I<sup>2</sup>C bus format, when arbitration is lost, MST and TRS are both reset by hardware, causing a transition to slave receive mode. In slave receive mode with the addressing format (FS = 0 or FSX = 0), hardware automatically selects transmit or receive mode according to the R/W bit in the first frame after a start condition.

Modification of the TRS bit during transfer is deferred until transfer of the frame containing the acknowledge bit is completed, and the changeover is made after completion of the transfer.

MST and TRS select the operating mode as follows.

Bit 5	Bit 4	Description
MST	TRS	
0	0	Slave receive mode (Initial value)
	1	Slave transmit mode
1	0	Master receive mode
	1	Master transmit mode

**Bit 5**

MST	Description
0	Slave mode (Initial value) [Clearing conditions] (1) When 0 is written by software (2) When bus arbitration is lost after transmission is started in I <sup>2</sup> C bus format master mode
1	Master mode [Setting conditions] (1) When 1 is written by software (in cases other than clearing condition 2) (2) When 1 is written in MST after reading MST = 0 (in case of clearing condition 2)

**Bit 4**

TRIS	Description
0	Receive mode (Initial value) [Clearing conditions] (1) When 0 is written by software (in cases other than setting condition 3) (2) When 0 is written in TRIS after reading TRS = 1 (in case of setting condition 3) (3) When bus arbitration is lost after transmission is started in I <sup>2</sup> C bus format master mode
1	Transmit mode [Setting conditions] (1) When 1 is written by software (in cases other than clearing conditions 3) (2) When 1 is written in TRIS after reading TRS = 0 (in case of clearing conditions 3) (3) When a 1 is received as the R/W bit of the first frame in I <sup>2</sup> C bus format slave mode

**Bit 3—Acknowledge Bit Judgement Selection (ACKE):** Specifies whether the value of the acknowledge bit returned from the receiving device when using the I<sup>2</sup>C bus format is to be ignored and continuous transfer is performed, or transfer is to be aborted and error handling, etc., performed if the acknowledge bit is 1. When the ACKE bit is 0, the value of the received acknowledge bit is not indicated by the ACKB bit, which is always 0.

When the ACKE bit is 0, the TDRE, IRIC, and IRTR flags are set on completion of data transmission, regardless of the value of the acknowledge bit. When the ACKE bit is 1, the TDRE, IRIC, and IRTR flags are set on completion of data transmission when the acknowledge bit is 0, and the IRIC flag alone is set on completion of data transmission when the acknowledge bit is 1. Depending on the receiving device, the acknowledge bit may be significant, in indicating completion of processing of the received data, for instance, or may be fixed at 1 and have no significance.

**Bit 3**

ACKE	Description
0	The value of the acknowledge bit is ignored, and continuous transfer is performed (Initial value)
1	If the acknowledge bit is 1, continuous transfer is interrupted

**Bit 2—Bus Busy (BBSY):** The BBSY flag can be read to check whether the I<sup>2</sup>C bus (SCL, SDA) is busy or free. In master mode, this bit is also used to issue start and stop conditions.

A high-to-low transition of SDA while SCL is high is recognized as a start condition, setting BBSY to 1. A low-to-high transition of SDA while SCL is high is recognized as a stop condition, clearing BBSY to 0.

To issue a start condition, use a MOV instruction to write 1 in BBSY and 0 in SCP. A retransmit start condition is issued in the same way. To issue a stop condition, use a MOV instruction to write 0 in BBSY and 0 in SCP.

It is not possible to write to BBSY in slave mode; the I<sup>2</sup>C bus interface must be set to master transmit mode before issuing a start condition. MST and TRS should both be set to 1 before writing 1 in BBSY and 0 in SCP.

## Bit 2

BBSY	Description
0	Bus is free [Clearing condition] When a stop condition is detected
1	Bus is busy [Setting condition] When a start condition is detected

**Bit 1—I<sup>2</sup>C Bus Interface Interrupt Request Flag (IRIC):** Indicates that the I<sup>2</sup>C bus interface has issued an interrupt request to the CPU. IRIC is set to 1 at the end of a data transfer, when a slave address or general call address is detected in slave receive mode, when bus arbitration is lost in master transmit mode, and when a stop condition is detected. IRIC is set at different times depending on the FS bit in SAR and the WAIT bit in ICMR. See section 25.3.6, IRIC Setting Timing and SCL Control. The conditions under which IRIC is set also differ depending on the setting of the ACKC bit in ICCR.

IRIC is cleared by reading IRIC after it has been set to 1, then writing 0 in IRIC.

When the DTC is used, IRIC is cleared automatically and transfer can be performed continuously without CPU intervention.



**Bit 1**

<b>IRIC</b>	<b>Description</b>
0	<p>Waiting for transfer, or transfer in progress (Initial value)</p> <p>[Clearing condition]</p> <p>When 0 is written in IRIC after reading IRIC = 1</p>
1	<p>Interrupt requested</p> <p>[Setting conditions]</p> <ul style="list-style-type: none"> <li>• I<sup>2</sup>C bus format master mode           <ol style="list-style-type: none"> <li>(1) When a start condition is detected in the bus line state after a start condition is issued (when the TDRE flag is set to 1 because of first frame transmission)</li> <li>(2) When a wait is inserted between the data and acknowledge bit when WAIT = 1</li> <li>(3) At the end of data transfer (at the rise of the 9th transmit clock pulse, and at the fall of the 8th transmit/receive clock pulse when a wait is inserted)</li> <li>(4) When a slave address is received after bus arbitration is lost (when the AL flag is set to 1)</li> <li>(5) When 1 is received as the acknowledge bit when the ACKE bit is 1 (when the ACKB bit is set to 1)</li> </ol> </li> <li>• I<sup>2</sup>C bus format slave mode           <ol style="list-style-type: none"> <li>(1) When the slave address (SVA, SVAX) matches (when the AAS and AASX flags are set to 1) and at the end of data transfer up to the subsequent retransmission start condition or stop condition detection (when the TDRE or RDRF flag is set to 1)</li> <li>(2) When the general call address is detected (when FS = 0 and the ADZ flag is set to 1) and at the end of data transfer up to the subsequent retransmission start condition or stop condition detection (when the TDRE or RDRF flag is set to 1)</li> <li>(3) When 1 is received as the acknowledge bit when the ACKE bit is 1 (when the ACKB bit is set to 1)</li> <li>(4) When a stop condition is detected (when the STOP or ESTP flag is set to 1)</li> </ol> </li> <li>• Synchronous serial format           <ol style="list-style-type: none"> <li>(1) At the end of data transfer (when the TDRE or RDRF flag is set to 1)</li> <li>(2) When a start condition is detected with serial format selected</li> </ol> </li> </ul> <p>When conditions are occurred such that the TDRE or RDRF flag is set to 1</p>

When, with the I<sup>2</sup>C bus format selected, IRIC is set to 1 and an interrupt is generated, other flags must be checked in order to identify the source that set IRIC to 1. Although each source has a

corresponding flag, caution is needed at the end of a transfer.

When the TDRE or RDRF internal flag is set, the readable IRTR flag may or may not be set. The IRTR flag (the DTC\* start request flag) is not set at the end of a data transfer up to detection of a retransmission start condition or stop condition after a slave address (SVA) or general call address match in I<sup>2</sup>C bus format slave mode.

Even when the IRIC flag and IRTR flag are set, the TDRE or RDRF internal flag may not be set. The IRIC and IRTR flags are not cleared at the end of the specified number of transfers in continuous transfer using the DTC\*. The TDRE or RDRF flag is cleared, however, since the specified number of ICDR reads or writes have been completed.

Table 25.3 shows the relationship between the flags and the transfer states.

Note: \* This LSI does not incorporate DTC.

**Table 25.3 Flags and Transfer States**

MST	TRS	BBSY	ESTP	STOP	IRTR	AASX	AL	AAS	ADZ	ACKB	State
1/0	1/0	0	0	0	0	0	0	0	0	0	Idle state (flag clearing required)
1	1	0	0	0	0	0	0	0	0	0	Start condition issuance
1	1	1	0	0	1	0	0	0	0	0	Start condition established
1	1/0	1	0	0	0	0	0	0	0	0/1	Master mode wait
1	1/0	1	0	0	1	0	0	0	0	0/1	Master mode transmit/receive end
0	0	1	0	0	0	1/0	1	1/0	1/0	0	Arbitration lost
0	0	1	0	0	0	0	0	1	0	0	SAR match by first frame in slave mode
0	0	1	0	0	0	0	0	1	1	0	General call address match
0	0	1	0	0	0	1	0	0	0	0	SARX match
0	1/0	1	0	0	0	0	0	0	0	0/1	Slave mode transmit/receive end (except after SARX match)
0	1/0	1	0	0	1	1	0	0	0	0	Slave mode transmit/receive end (after SARX match)
0	1/0	0	1/0	1/0	0	0	0	0	0	0/1	Stop condition detected

**Bit 0—Start Condition/Stop Condition Prohibit (SCP):** Controls the issuing of start and stop conditions in master mode. To issue a start condition, write 1 in BBSY and 0 in SCP. A retransmit start condition is issued in the same way. To issue a stop condition, write 0 in BBSY and 0 in SCP. This bit is always read as 1. If 1 is written, the data is not stored.

**Bit 0**

SCP	Description
0	Writing 0 issues a start or stop condition, in combination with the BBSY flag
1	Reading always returns a value of 1 (Initial value) Writing is ignored

**25.2.6 I<sup>2</sup>C Bus Status Register (ICSR)**

Bit :	7	6	5	4	3	2	1	0
	ESTP	STOP	IRTR	AASX	AL	AAS	ADZ	ACKB
Initial value :	0	0	0	0	0	0	0	0
R/W :	R/(W)*	R/(W)*	R/(W)*	R/(W)*	R/(W)*	R/(W)*	R/(W)*	R/W

Note: \* Only 0 can be written to clear the flag.

ICSR is an 8-bit readable/writable register that performs flag confirmation and acknowledge confirmation and control.

ICSR is initialized to H'00 by a reset.

**Bit 7—Error Stop Condition Detection Flag (ESTP):** Indicates that a stop condition has been detected during frame transfer in I<sup>2</sup>C bus format slave mode.

**Bit 7**

ESTP	Description
0	No error stop condition (Initial value) [Clearing conditions] (1) When 0 is written in ESTP after reading ESTP = 1 (2) When the IRIC flag is cleared to 0
1	<ul style="list-style-type: none"> <li>In I<sup>2</sup>C bus format slave mode Error stop condition detected</li> </ul> [Setting condition] When a stop condition is detected during frame transfer <ul style="list-style-type: none"> <li>In other modes No meaning</li> </ul>

**Bit 6—Normal Stop Condition Detection Flag (STOP):** Indicates that a stop condition has been detected after completion of frame transfer in I<sup>2</sup>C bus format slave mode.

**Bit 6**

<b>STOP</b>	<b>Description</b>
0	No normal stop condition (Initial value) [Clearing conditions] (1) When 0 is written in STOP after reading STOP = 1 (2) When the IRIC flag is cleared to 0
1	<ul style="list-style-type: none"><li>In I<sup>2</sup>C bus format slave mode Error stop condition detected</li></ul> [Setting condition] When a stop condition is detected after completion of frame transfer <ul style="list-style-type: none"><li>In other modes No meaning</li></ul>

**Bit 5—I<sup>2</sup>C Bus Interface Continuous Transmission/Reception Interrupt Request Flag**

**(IRTR):** Indicates that the I<sup>2</sup>C bus interface has issued an interrupt request to the CPU, and the source is completion of reception/transmission of one frame in continuous transmission/reception for which DTC\* activation is possible. When the IRTR flag is set to 1, the IRIC flag is also set to 1 at the same time.

IRTR flag setting is performed when the TDRE or RDRF flag is set to 1. IRTR is cleared by reading IRTR after it has been set to 1, then writing 0 in IRTR. IRTR is also cleared automatically when the IRIC flag is cleared to 0.

Note: \* This LSI does not incorporate DTC.

**Bit 5**

<b>IRTR</b>	<b>Description</b>
0	Waiting for transfer, or transfer in progress (Initial value) [Clearing conditions] (1) When 0 is written in IRTR after reading IRTR = 1 (2) When the IRIC flag is cleared to 0
1	Continuous transfer state [Setting conditions] <ul style="list-style-type: none"> <li>• In I<sup>2</sup>C bus interface slave mode When the TDRE or RDRF flag is set to 1 when AASX = 1</li> <li>• In other modes When the TDRE or RDRF flag is set to 1</li> </ul>

**Bit 4—Second Slave Address Recognition Flag (AASX):** In I<sup>2</sup>C bus format slave receive mode, this flag is set to 1 if the first frame following a start condition matches bits SVAX6 to SVAX0 in SARX.

AASX is cleared by reading AASX after it has been set to 1, then writing 0 in AASX. AASX is also cleared automatically when a start condition is detected.

**Bit 4**

AASX	Description
0	Second slave address not recognized (Initial value) [Clearing conditions] (1) When 0 is written in AASX after reading AASX = 1 (2) When a start condition is detected (3) In master mode
1	Second slave address recognized [Setting condition] When the second slave address is detected in slave receive mode while FSX = 0

**Bit 3—Arbitration Lost (AL):** This flag indicates that arbitration was lost in master mode. The I<sup>2</sup>C bus interface monitors the bus. When two or more master devices attempt to seize the bus at nearly the same time, if the I<sup>2</sup>C bus interface detects data differing from the data it sent, it sets AL to 1 to indicate that the bus has been taken by another master.

AL is cleared by reading AL after it has been set to 1, then writing 0 in AL. In addition, AL is reset automatically by write access to ICDR in transmit mode, or read access to ICDR in receive mode.

**Bit 3**

AL	Description
0	Bus arbitration won (Initial value) [Clearing conditions] (1) When ICDR data is written (transmit mode) or read (receive mode) (2) When 0 is written in AL after reading AL = 1
1	Arbitration lost [Setting conditions] (1) If the internal SDA and SDA pin disagree at the rise of SCL in master transmit mode (2) If the internal SCL line is high at the fall of SCL in master transmit mode

**Bit 2—Slave Address Recognition Flag (AAS):** In I<sup>2</sup>C bus format slave receive mode, this flag is set to 1 if the first frame following a start condition matches bits SVA6 to SVA0 in SAR, or if the general call address (H'00) is detected.

AAS is cleared by reading AAS after it has been set to 1, then writing 0 in AAS. In addition, AAS is reset automatically by write access to ICDR in transmit mode, or read access to ICDR in receive mode.

### Bit 2

AAS	Description
0	Slave address or general call address not recognized (Initial value) [Clearing conditions] (1) When ICDR data is written (transmit mode) or read (receive mode) (2) When 0 is written in AAS after reading AAS = 1 (3) In master mode
1	Slave address or general call address recognized [Setting condition] When the slave address or general call address is detected in slave receive mode

**Bit 1—General Call Address Recognition Flag (ADZ):** In I<sup>2</sup>C bus format slave receive mode, this flag is set to 1 if the first frame following a start condition is the general call address (H'00). ADZ is cleared by reading ADZ after it has been set to 1, then writing 0 in ADZ. In addition, ADZ is reset automatically by write access to ICDR in transmit mode, or read access to ICDR in receive mode.

### Bit 1

ADZ	Description
0	General call address not recognized (Initial value) [Clearing conditions] (1) When ICDR data is written (transmit mode) or read (receive mode) (2) When 0 is written in ADZ after reading ADZ = 1 (3) In master mode
1	General call address recognized [Setting condition] If the general call address is detected when FSX = 0 or FS = 0 is selected in the slave receive mode.

**Bit 0—Acknowledge Bit (ACKB):** Stores acknowledge data. In transmit mode, after the receiving device receives data, it returns acknowledge data, and this data is loaded into ACKB. In receive mode, after data has been received, the acknowledge data set in this bit is sent to the transmitting device.

When this bit is read, in transmission (when TRS = 1), the value loaded from the bus line (returned by the receiving device) is read. In reception (when TRS = 0), the value set by internal software is read.

**Bit 0**

ACKB	Description
0	Receive mode: 0 is output at acknowledge output timing (Initial value) Transmit mode: Indicates that the receiving device has acknowledged the data (signal is 0)
1	Receive mode: 1 is output at acknowledge output timing Transmit mode: Indicates that the receiving device has not acknowledged the data (signal is 1)

**25.2.7 Serial/Timer Control Register (STCR)**

Bit :	7	6	5	4	3	2	1	0
	—	IICX	IICRST	—	FLSHE	—	—	—
Initial value :	0	0	0	0	0	0	0	0
R/W :	—	R/W	R/W	—	R/W	—	—	—

STCR is an 8-bit readable/writable register that controls the I<sup>2</sup>C bus interface operating mode. STCR is initialized to H'00 by a reset.

**Bit 7—Reserved**

**Bit 6—I<sup>2</sup>C Transfer Select (IICX):** This bit, together with bits CKS2 to CKS0 in ICMR of I<sup>2</sup>C, selects the transfer rate in master mode. For details, see section 25.2.4, I<sup>2</sup>C Bus Mode Register (ICMR).



**Bit 5—I<sup>2</sup>C Controller Reset (IICRST):** This bit controls the initialization of the internal state of the I<sup>2</sup>C bus interface. When the I<sup>2</sup>C bus interface operating mode is hung because of communications error, and the IICRST bit is then set to 1, the I<sup>2</sup>C bus interface controller is initialized of the internal state, and this allows the internal state of the I<sup>2</sup>C bus interface to be initialized without making port settings or initializing registers.

For the detail, refer to section 25.3.9, Initialization of Internal State.

The initialization is continuous and the I<sup>2</sup>C bus interface cannot operate, when the IICST bit remains set to 1. Therefore, be sure to clear the IICRST bit after setting it.

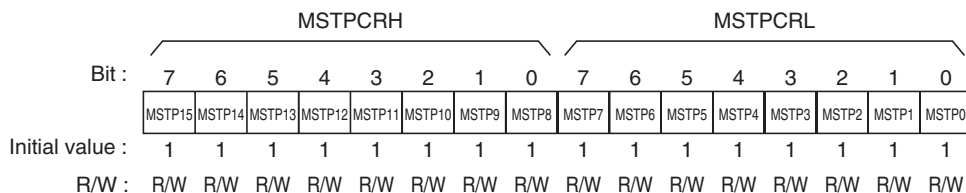
#### Bit 5

IICRST	Description
0	I <sup>2</sup> C bus interface controller is not reset (Initial value)
1	I <sup>2</sup> C bus interface controller is reset

**Bits 3—Flash Memory Control Resister Enable (FLSHE):** This bit selects the control resister of the flash memory. For details, refer to section 7.3.4 or 8.3.5, Serial/Timer Control Resister (STCR).

#### Bits 4 and 2 to 0—Reserved

### 25.2.8 Module Stop Control Register (MSTPCR)



MSTPCR comprises two 8-bit readable/writable registers, and is used to perform module stop mode control.

When the corresponding bit in MSTPCR is set to 1, operation of the corresponding I<sup>2</sup>C module is halted at the end of the bus cycle, and a transition is made to module stop mode. For details, see section 4.5, Module Stop Mode.

MSTPCR is initialized to H'FFFF by a reset. It is not initialized in standby mode.

**MSTPCRL Bit 6—Module Stop (MSTP6):** Specifies I<sup>2</sup>C module stop mode.

**MSTPCRL**

---

**Bit 6**

---

<b>MSTP6</b>	<b>Description</b>
0	I <sup>2</sup> C module stop mode is cleared
1	I <sup>2</sup> C module stop mode is set (Initial value)

---

## 25.3 Operation

### 25.3.1 I<sup>2</sup>C Bus Data Format

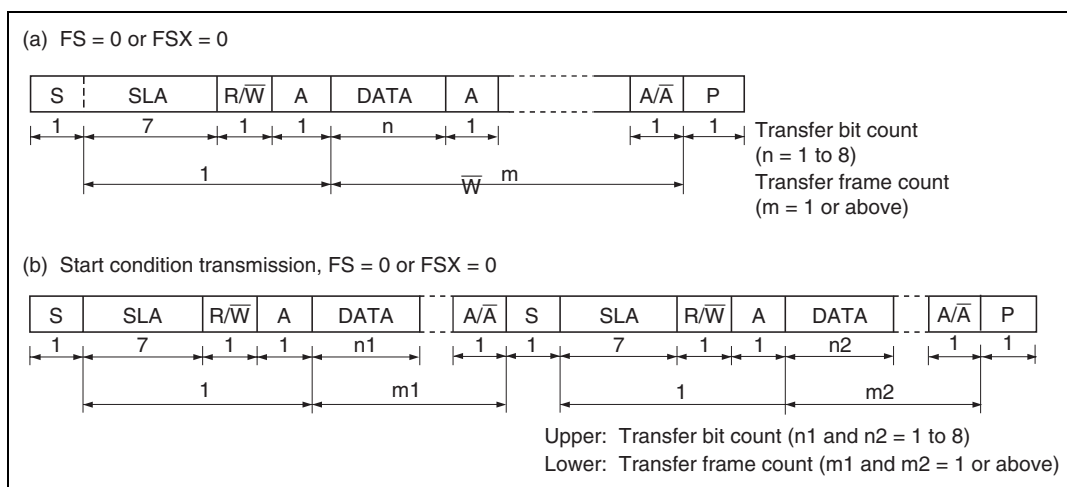
The I<sup>2</sup>C bus interface has serial and I<sup>2</sup>C bus formats.

The I<sup>2</sup>C bus formats are addressing formats with an acknowledge bit. These are shown in figure 25.3. The first frame following a start condition always consists of 8 bits.

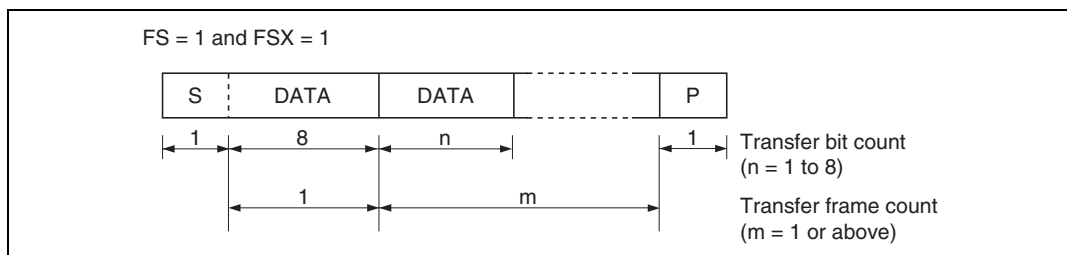
The serial format is a non-addressing format with no acknowledge bit. This is shown in figure 25.4.

Figure 25.5 shows the I<sup>2</sup>C bus timing.

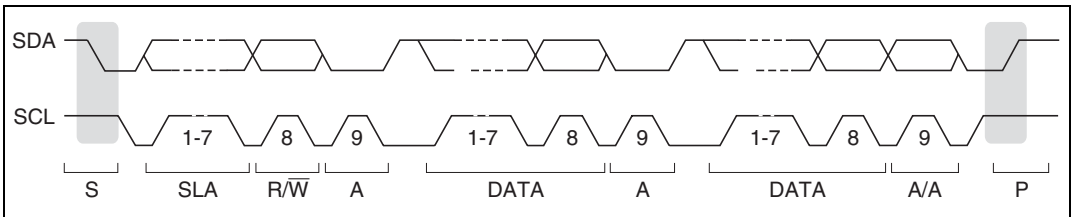
The symbols used in figures 25.3 to 25.5 are explained in table 25.4.



**Figure 25.3 I<sup>2</sup>C Bus Data Formats (I<sup>2</sup>C Bus Formats)**



**Figure 25.4 I<sup>2</sup>C Bus Data Format (Serial Format)**

Figure 25.5 I<sup>2</sup>C Bus TimingTable 25.4 I<sup>2</sup>C Bus Data Format Symbols

S	Start condition. The master device drives SDA from high to low while SCL is high
SLA	Slave address, by which the master device selects a slave device
R/W	Indicates the direction of data transfer: from the slave device to the master device when R/W is 1, or from the master device to the slave device when R/W is 0
A	Acknowledge. The receiving device (the slave in master transmit mode, or the master in master receive mode) drives SDA low to acknowledge a transfer
DATA	Transferred data. The bit length is set by bits BC2 to BC0 in ICMR. The MSB-first or LSB-first format is selected by bit MLS in ICMR
P	Stop condition. The master device drives SDA from low to high while SCL is high

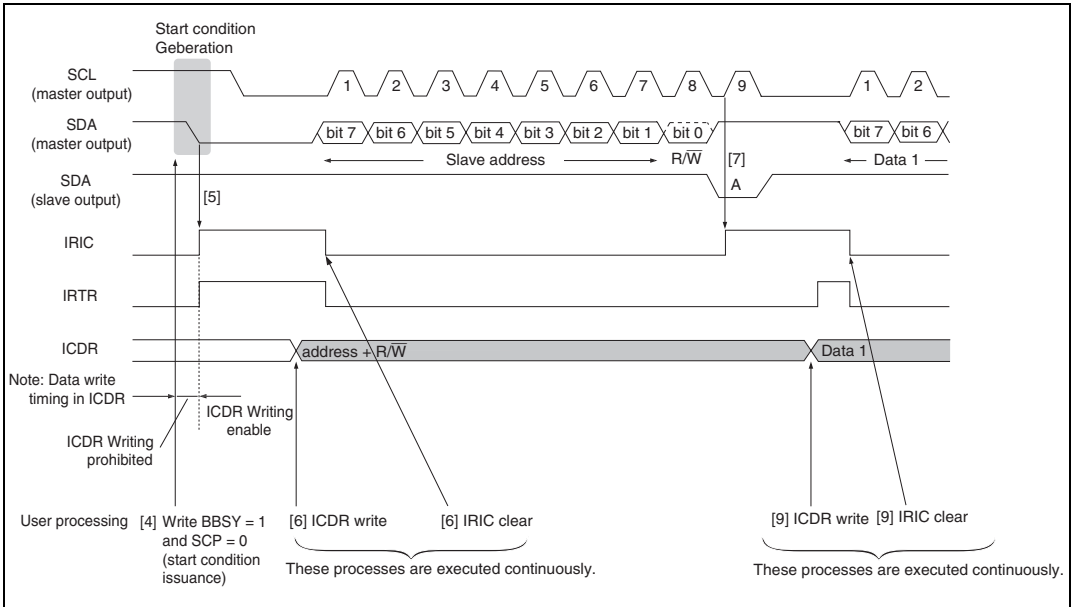
### 25.3.2 Master Transmit Operation

In I<sup>2</sup>C bus format master transmit mode, the master device outputs the transmit clock and transmit data, and the slave device returns an acknowledge signal. The transmission procedure and operations synchronize with the ICDR writing are described below.

- [1] Set bit ICE in ICCR to 1. Set bits MLS, WAIT, CKS2 to CKS0 in ICMR, and bit IICX in STCR, according to the operating mode.
- [2] Read the BBSY flag in ICCR to confirm that the bus is free.
- [3] Set bits MST and TRS to 1 in ICCR to select master transmit mode.
- [4] Write 1 to BBSY and 0 to SCP. This changes SDA from high to low when SCL is high, and generates the start condition.
- [5] Then IRIC and IRTR flags are set to 1. If the IEIC bit in ICCR has been set to 1, an interrupt request is sent to the CPU.
- [6] Write the data (slave address + R/W) to ICDR. After the start condition instruction has been issued and the start condition has been generated, write data to ICDR. If this procedure is not followed, data may not be output correctly. With the I<sup>2</sup>C bus format (when the FS bit in SAR or the FSX bit in SARX is 0), the first frame data following the start condition indicates the 7-bit slave address and transmit/receive direction. As indicating the end of the transfer, and so

the IRIC flag is cleared to 0. After writing ICDR, clear IRIC immediately not to execute other interrupt handling routine. If one frame of data has been transmitted before the IRIC clearing, it can not be determine the end of transmission. The master device sequentially sends the transmission clock and the data written to ICDR using the timing shown in figure 25.6. The selected slave device (i.e. the slave device with the matching slave address) drives SDA low at the 9th transmit clock pulse and returns an acknowledge signal.

- [7] When one frame of data has been transmitted, the IRIC flag is set to 1 at the rise of the 9th transmit clock pulse. After one frame has been transmitted SCL is automatically fixed low in synchronization with the internal clock until the next transmit data is written.
- [8] Read the ACKB bit in ICSR to confirm that ACKB is cleared to 0. When the slave device has not acknowledged (ACKB bit is 1), operate the step [12] to end transmission, and retry the transmit operation.
- [9] Write the transmit data to ICDR. As indicating the end of the transfer, and so the IRIC flag is cleared to 0. After writing ICDR, clear IRIC immediately not to execute other interrupt handling routine. The master device sequentially sends the transmission clock and the data written to ICDR. Transmission of the next frame is performed in synchronization with the internal clock.
- [10] When one frame of data has been transmitted, the IRIC flag is set to 1 at the rise of the 9th transmit clock pulse. After one frame has been transmitted SCL is automatically fixed low in synchronization with the internal clock until the next transmit data is written.
- [11] Read the ACKB bit in ICSR and confirm ACKB is cleared to 0. When there is data to be transmitted, go to the step [9] to continue next transmission. When the slave device has not acknowledged (ACKB bit is set to 1), operate the step [12] to end transmission.
- [12] Clear the IRIC flag to 0. And write 0 to BBSY and SCP in ICCR. This changes SDA from low to high when SCL is high, and generates the stop condition.



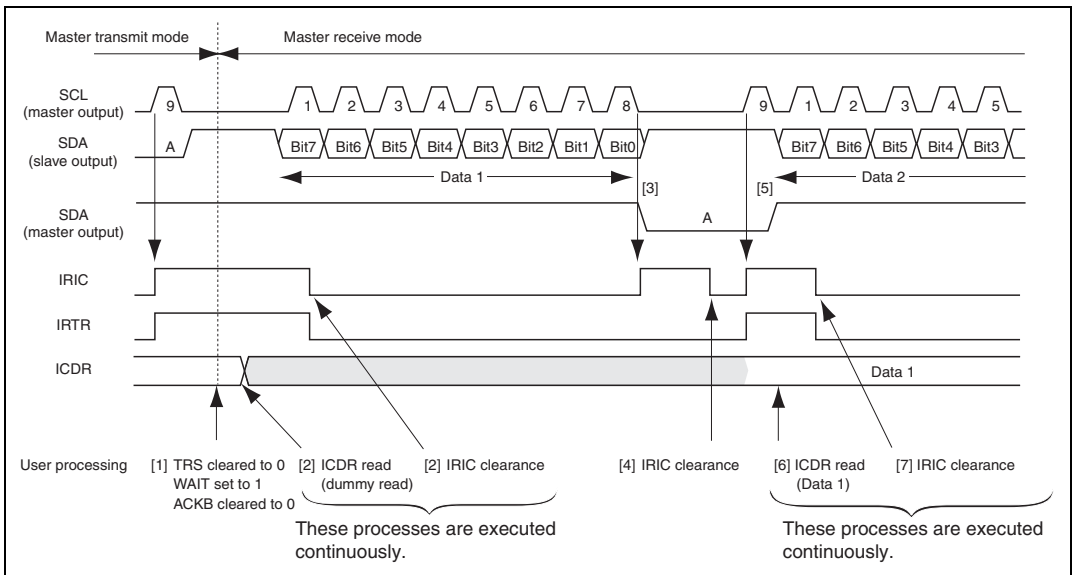
**Figure 25.6 Example of Master Transmit Mode Operation Timing (MLS = WAIT = 0)**

### 25.3.3 Master Receive Operation

In master receive mode, the master device outputs the receive clock, receives data, and returns an acknowledge signal. The slave device transmits data. I<sup>2</sup>C bus interface module consists of the data buffers of ICDRR and ICDRS, so data can be received continuously in master receive mode. For this construction, when stop condition issuing timing delayed, it may occurs the internal contention between stop condition issuance and SCL clock output for next data receiving, and then the extra SCL clock would be outputted automatically or the SCL line would be held to low. And for I<sup>2</sup>C bus interface system, the acknowledge bit must be set to 1 at the last data receiving, so the change timing of ACKB bit in ICSR should be controlled by software. To take measures against these problems, the wait function should be used in master receive mode. The reception procedure and operations with the wait function in master receive mode are described below.

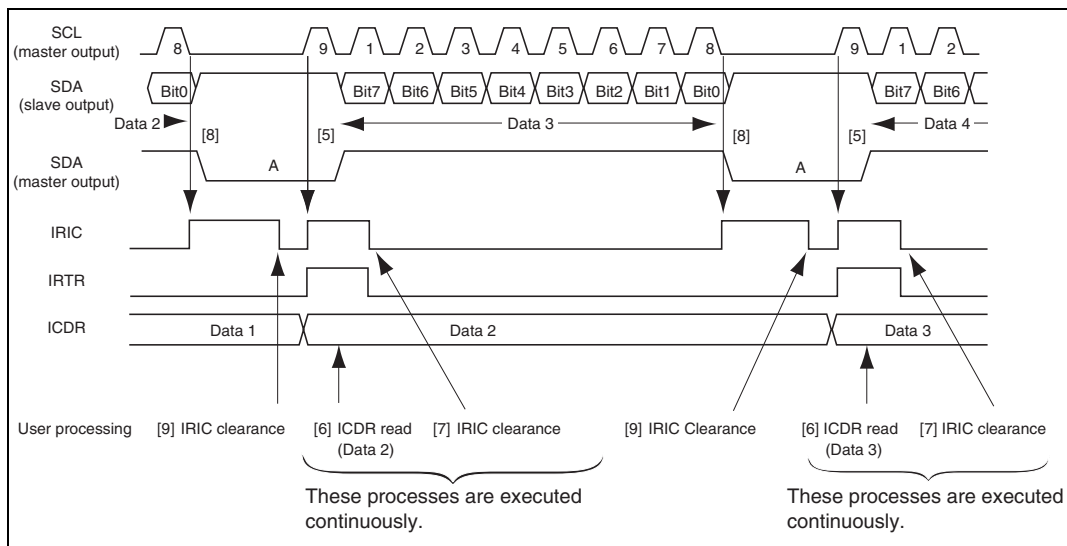
- [1] Clear the TRS bit in ICCR to 0 to switch from transmit mode to receive mode, and set the WAIT bit in ICMR to 1. Also clear the ACKB bit in ICSR to 0 (acknowledge data setting).
- [2] When ICDR is read (dummy data read), reception is started, and the receive clock is output, and data received, in synchronization with the internal clock. In order to detect wait operation, set the IRIC flag in ICCR must be cleared to 0. After reading ICDR, clear IRIC immediately not to execute other interrupt handling routine. If one frame of data has been received before the IRIC clearing, it can not be determine the end of reception.
- [3] The IRIC flag is set to 1 at the fall of the 8th receive clock pulse. If the IEIC bit in ICCR has been set to 1, an interrupt request is sent to the CPU. SCL is automatically fixed low in synchronization with the internal clock until the IRIC flag clearing. If the first frame is the last receive data, execute step [10] to halt reception.
- [4] Clear the IRIC flag to release from the Wait State. The master device outputs the 9th clock and drives SDA at the 9th receive clock pulse to return an acknowledge signal.
- [5] When one frame of data has been received, the IRIC flag in ICCR and the IRTR flag in ICSR are set to 1 at the rise of the 9th receive clock pulse. The master device outputs SCL clock to receive next data.
- [6] Read ICDR.
- [7] Clear the IRIC flag to detect next wait operation. From clearing of the IRIC flag to negation of a wait as described in step [4] (and [9]) to clearing of the IRIC flag as described in steps [5], [6], and [7], must be performed within the time taken to transfer one byte.
- [8] The IRIC flags set to 1 at the fall of the 8th receive clock pulse. SCL is automatically fixed low in synchronization with the internal clock until the IRIC flag clearing. If this frame is the last receive data, execute step [10] to halt reception.
- [9] Clear the IRIC flag in ICCR to cancel wait operation. The master device outputs the 9th clock and drives SDA at the 9th receive clock pulse to return an acknowledge signal. Data can be received continuously by repeating steps [5] to [9].

- [10] Set the ACKB bit in ICSR to 1 so as to return “No acknowledge” data. Also set the TRS bit to 1 to switch from receive mode to transmit mode.
- [11] Clear IRIC flag to 0 to release from the Wait State.
- [12] When one frame of data has been received, the IRIC flag is set to 1 at the rise of the 9th receive clock pulse.
- [13] Clear the WAIT bit to 0 to switch from wait mode to no wait mode. Read ICDR and the IRIC flag to 0. Clearing of the IRIC flag should be after the WAIT = 0.
- (If the stop-condition generation command is executed after clearing the IRIC flag to 0 and then clearing the WAIT bit to 0, the SDA line is fixed low and the stop condition cannot be generated.)
- [14] Clear the BBSY bit and SCP bit to 0. This changes SDA from low to high when SCL is high, and generates the stop condition.



**Figure 25.7 Example of Master Receive Mode Operation Timing**  
(MLS = ACKB = 0, WAIT = 1)





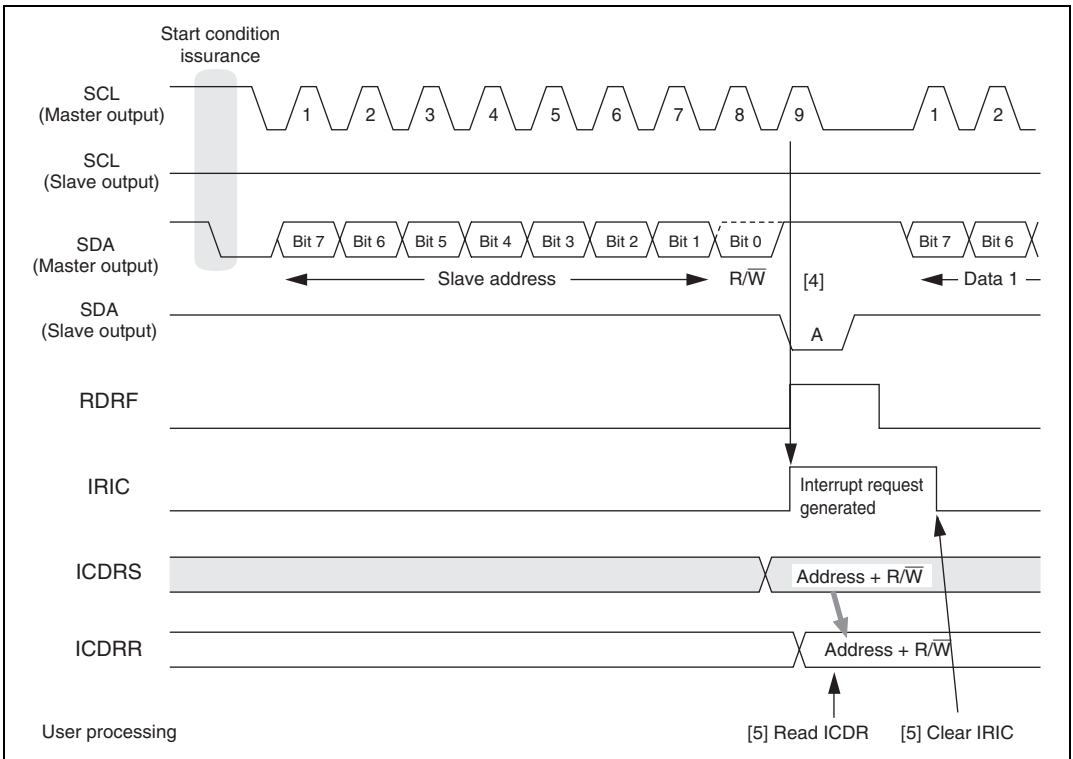
**Figure 25.8 Example of Master Receive Mode Operation Timing  
(MLS = ACKB = 0, WAIT = 1) Continued**

### 25.3.4 Slave Receive Operation

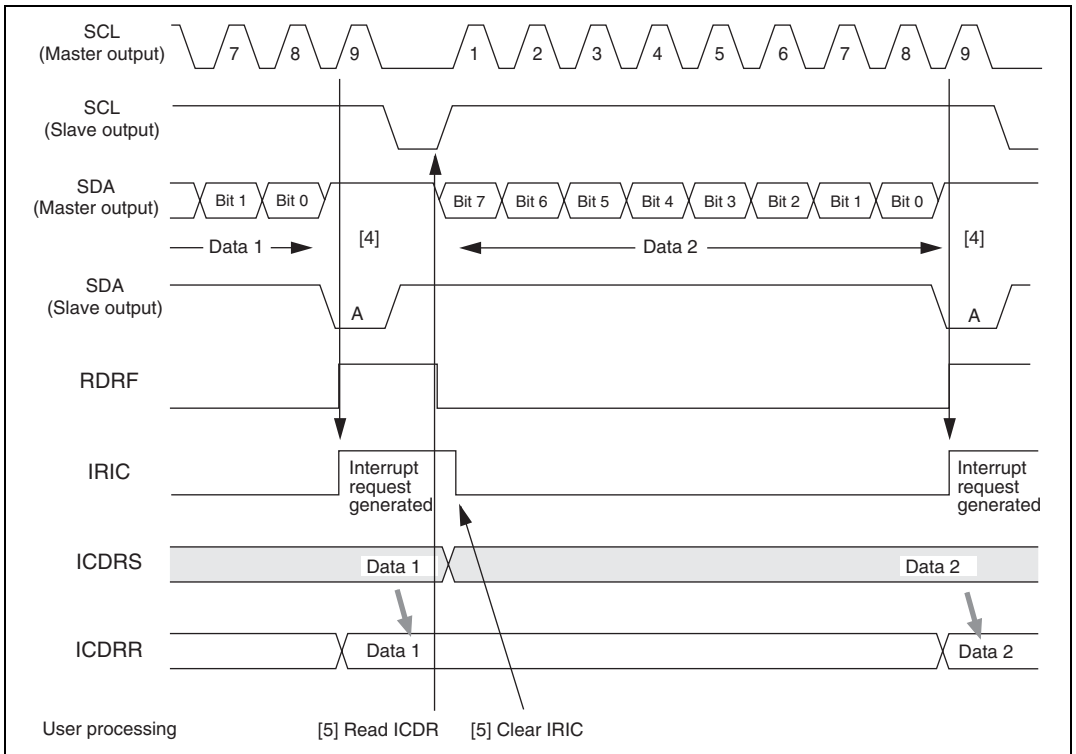
In slave receive mode, the master device outputs the transmit clock and transmit data, and the slave device returns an acknowledge signal. The receive procedure and operations in slave receive mode are described below.

- [1] Set bit ICE in ICCR to 1. Set bits MLS in ICMR and bits MST and TRS in ICCR according to the operating mode.
- [2] A start condition output by the master device sets the BBSY flag to 1 in ICCR.
- [3] After the slave device detects the start condition, if the first frame matches its slave address, it functions as the slave device designated as the master device. If the 8th bit data ( $R/\bar{W}$ ) is 0, TRS bit in ICCR remains 0 and executes slave receive operation.
- [4] At the ninth clock pulse of the receive frame, the slave device drives SDA low to acknowledge the transfer. At the same time, the IRIC flag is set to 1 in ICCR. If IEIC is 1 in ICCR, a CPU interrupt is requested. If the RDRF internal flag is 0, it is set to 1 and continuous reception is performed. If the RDRF internal flag is 1, the slave device holds SCL low from the fall of the receive clock until it has read the data in ICDR.
- [5] Read ICDR and clear IRIC to 0 in ICCR. At this time, the RDRF flag is cleared to 0.

Steps [4] and [5] can be repeated to receive data continuously. When a stop condition is detected (a low-to-high transition of SDA while SCL is high), the BBSY flag is cleared to 0 in ICCR.



**Figure 25.9 Example of Timing in Slave Receive Mode (MLS = ACKB = 0) (1)**



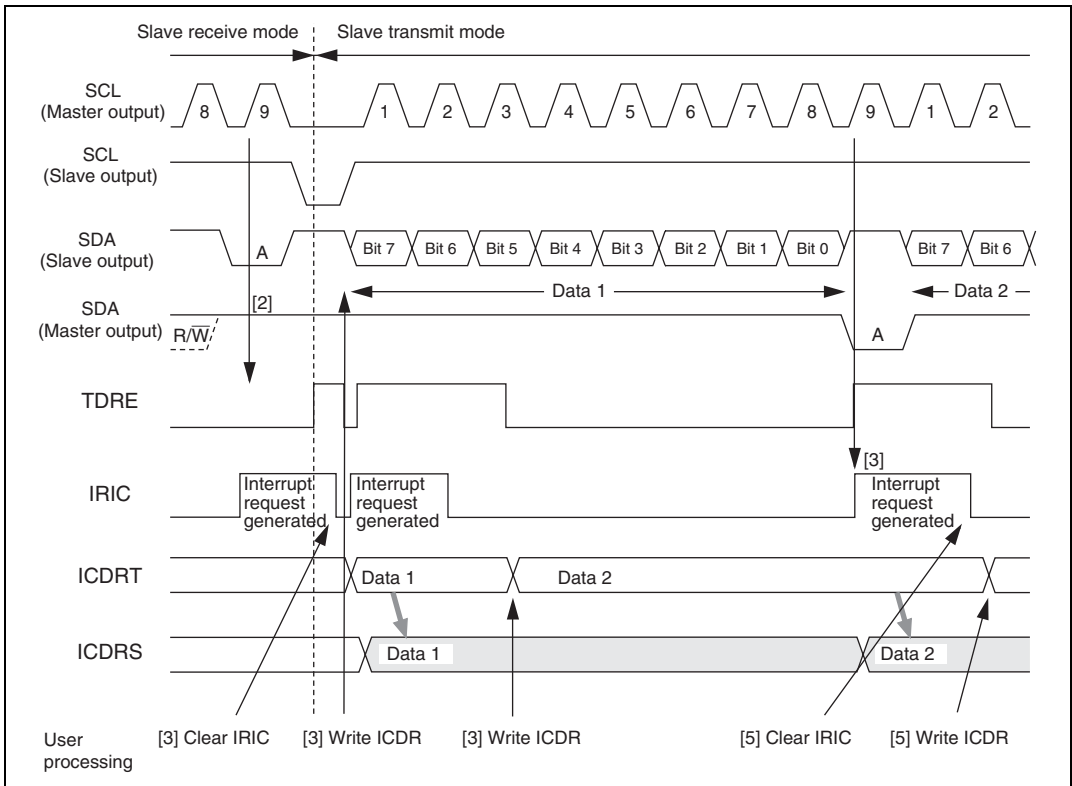
**Figure 25.10 Example of Timing in Slave Receive Mode (MLS = ACKB = 0) (2)**

### 25.3.5 Slave Transmit Operation

In slave transmit mode, the slave device outputs the transmit data, and the master device outputs the transmit clock and returns an acknowledge signal. The transmit procedure and operations in slave transmit mode are described below.

- [1] Set bit ICE in ICCR to 1. Set bits MLS in ICMR and bits MST and TRS in ICCR according to the operating mode.
- [2] After the slave device detects a start condition, if the first frame matches its slave address, at the ninth clock pulse the slave device drives SDA low to acknowledge the transfer. At the same time, the IRIC flag is set to 1 in ICCR, and if the IEIC bit in ICCR is set to 1 at this time, an interrupt request is sent to the CPU. If the eighth data bit (R/W) is 1, the TRS bit is set to 1 in ICCR, automatically causing a transition to slave transmit mode. The slave device holds SCL low from the fall of the transmit clock until data is written in ICDR.
- [3] Clear the IRIC flag to 0, then write data in ICDR. The written data is transferred to ICDRS, and the TDRE internal flag and the IRIC and IRTR flags are set to 1 again. Clear IRIC to 0, then write the next data in ICDR. The slave device outputs the written data serially in step with the clock output by the master device, with the timing shown in figure 25.11.
- [4] When one frame of data has been transmitted, at the rise of the ninth transmit clock pulse IRIC is set to 1 in ICCR. If the TDRE internal flag is 1, the slave device holds SCL low from the fall of the transmit clock until data is written in ICDR. The master device drives SDA low at the ninth clock pulse to acknowledge the data. The acknowledge signal is stored in the ACKB bit in ICSR, and can be used to check whether the transfer was carried out normally. If TDRE internal flag is set to 0, the data written in ICDR is transferred to ICDRS, then transmission starts and TDRE internal flag and IRIC and IRTR flags are all set to 1 again.
- [5] To continue transmitting, clear IRIC to 0, then write the next transmit data in ICDR.

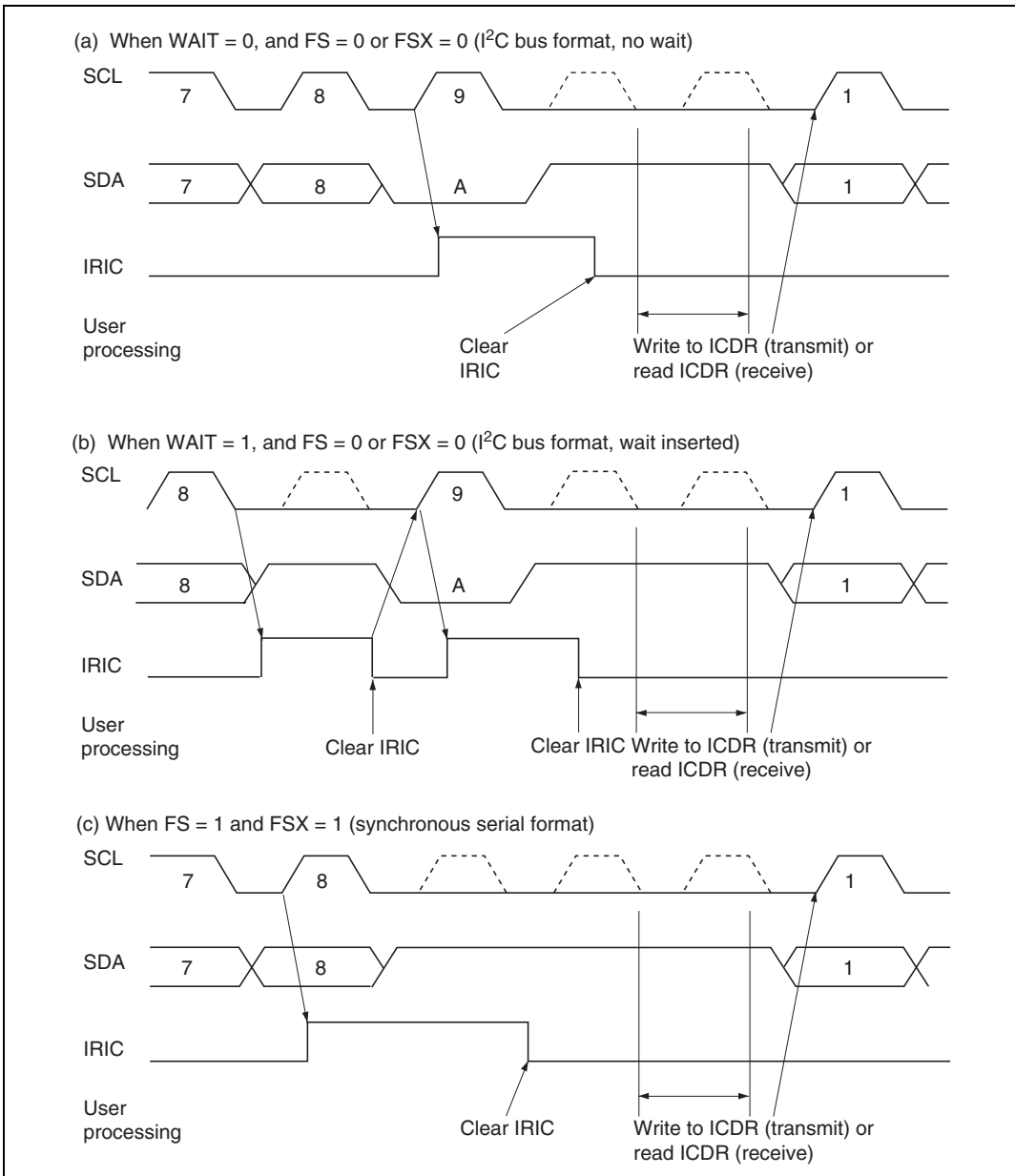
Steps [4] and [5] can be repeated to transmit continuously. To end the transmission, write H'FF in ICDR so that the SDA may be freed on the slave side. When a stop condition is detected (a low-to-high transition of SDA while SCL is high), the BBSY flag will be cleared to 0 in ICCR.



**Figure 25.11 Example of Timing in Slave Transmit Mode (MLS = 0)**

### 25.3.6 IRIC Setting Timing and SCL Control

The interrupt request flag (IRIC) is set at different times depending on the WAIT bit in ICMR, the FS bit in SAR, and the FSX bit in SARX. If the TDRE or RDRF internal flag is set to 1, SCL is automatically held low after one frame has been transferred; this timing is synchronized with the internal clock. Figure 25.12 shows the IRIC set timing and SCL control.

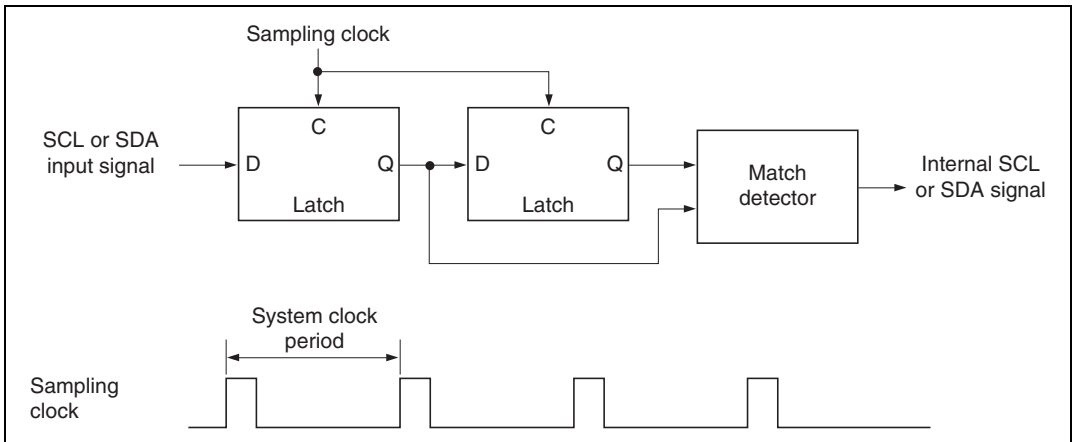


**Figure 25.12 IRIC Setting Timing and SCL Control**

### 25.3.7 Noise Canceler

The logic levels at the SCL and SDA pins are routed through noise cancelers before being latched internally. Figure 25.13 shows a block diagram of the noise canceler circuit.

The noise canceler consists of two cascaded latches and a match detector. The SCL (or SDA) input signal is sampled on the system clock, but is not passed forward to the next circuit unless the outputs of both latches agree. If they do not agree, the previous value is held.



**Figure 25.13 Block Diagram of Noise Canceler**

### 25.3.8 Sample Flowcharts

Figures 25.14 to 25.17 show sample flowcharts for using the I<sup>2</sup>C bus interface in each mode.

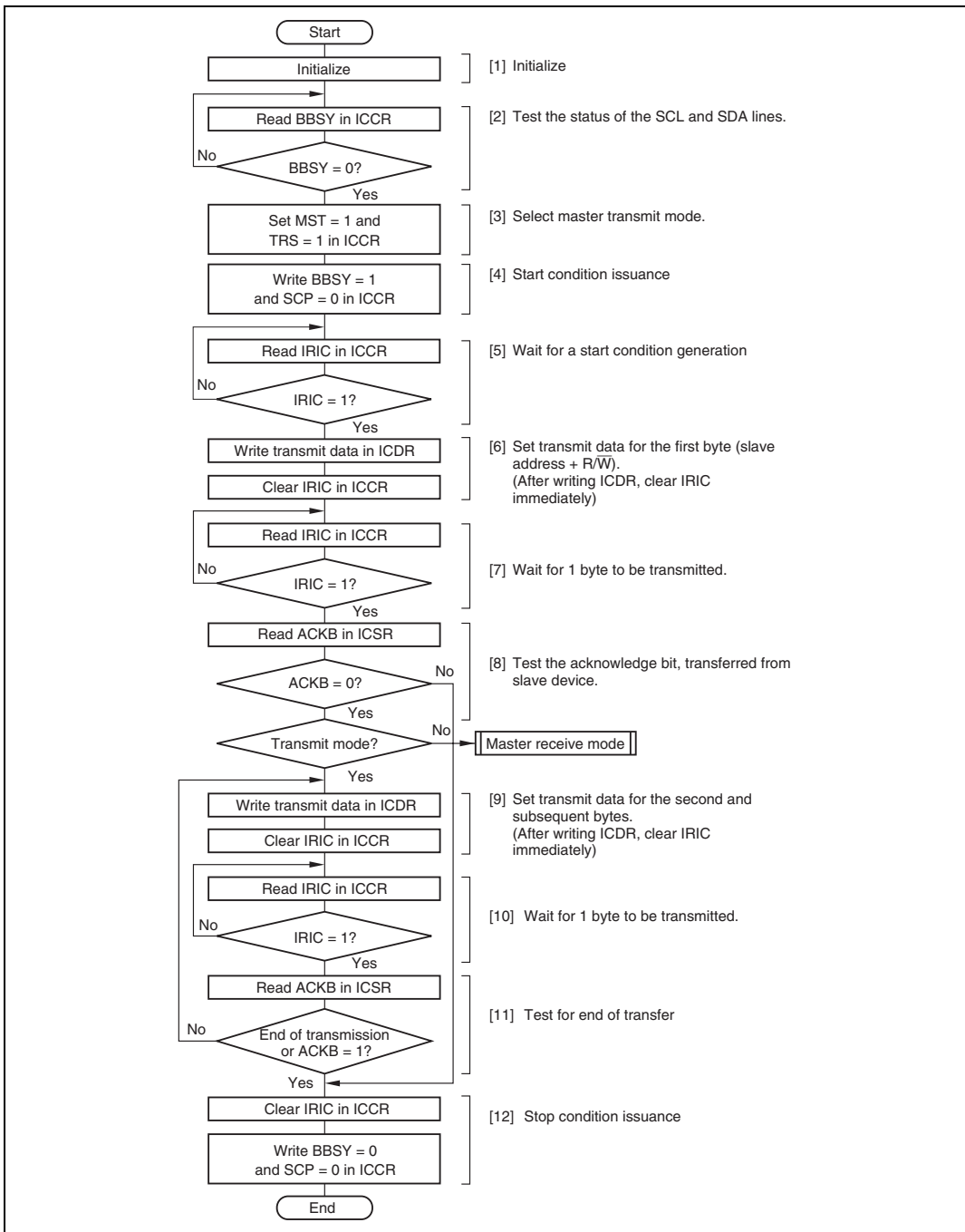


Figure 25.14 Flowchart for Master Transmit Mode (Example)



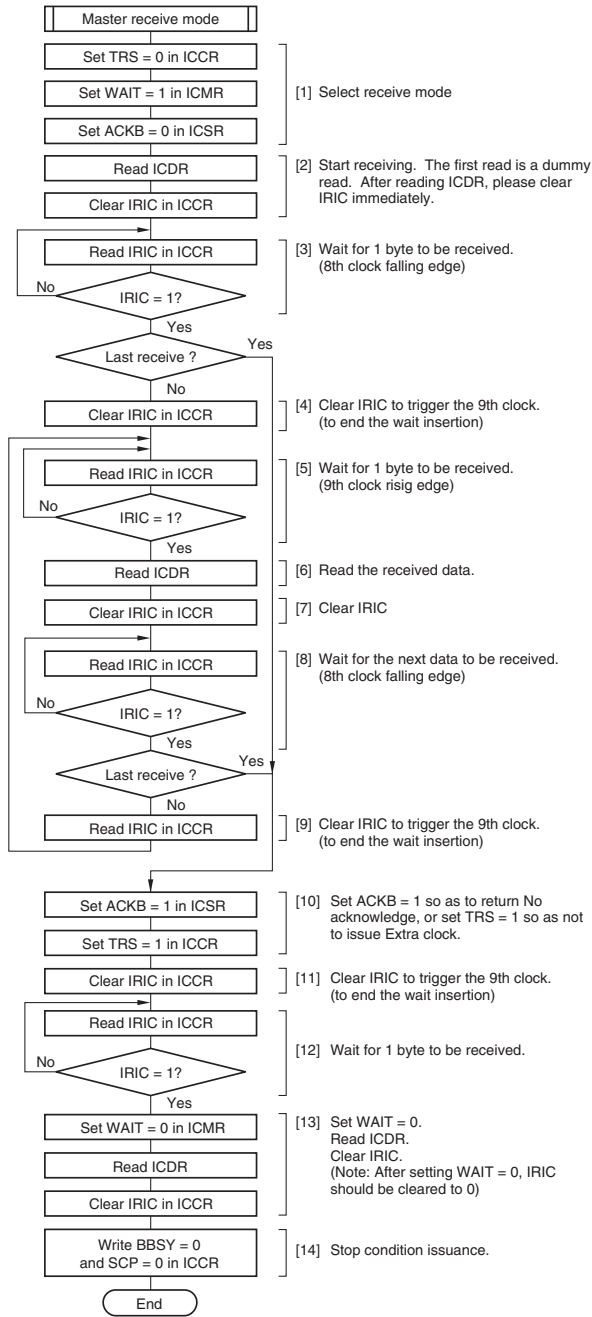
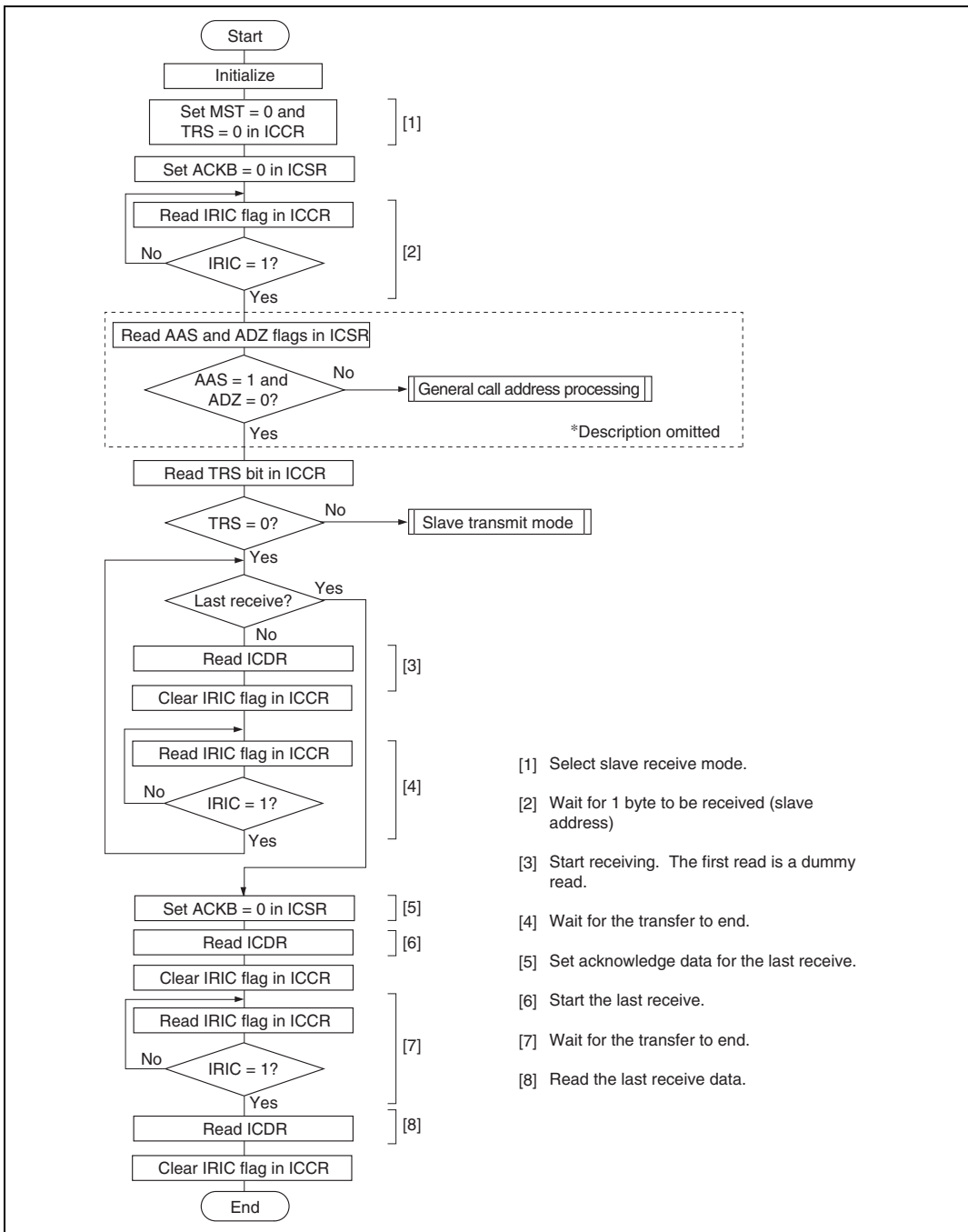
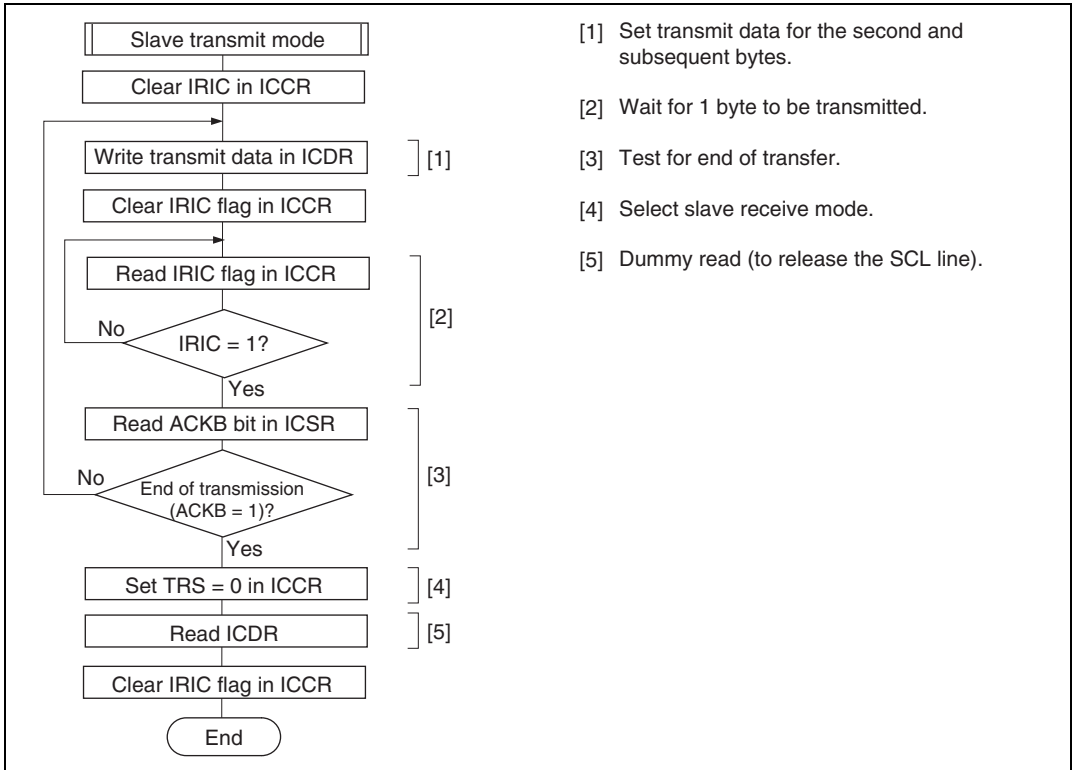


Figure 25.15 Flowchart for Master Receive Mode (Example)



**Figure 25.16 Flowchart for Slave Transmit Mode (Example)**



**Figure 25.17 Flowchart for Slave Receive Mode (Example)**

### 25.3.9 Initialization of Internal State

This I<sup>2</sup>C is capable of forcibly initializing internal state of I<sup>2</sup>C if deadlock develops during communication.

The initialization is done by setting IICRST bit in STCR register, or clearing ICE bit.

For details, see section 25.2.7, Serial/Time control Register (STCR).

#### (1) Range of Initialization

The following is initialized by this function:

- Internal flags of TDRE and RDRF
- Programmable logic controller for signal receiving and sending.
- Internal latches used for holding outputs from SCL and SDA pins (wait, clock, data output, etc.).

The following is not initialized by this function:

- Register values (ICDR, SAR, SARX, ICMR, ICCR, ICSR, and STCR).
- Internal latches employed for maintaining data read from the registers which is used for setting or clearing flags on ICMR, ICCR, and ICSR registers.
- Values on the ICMR register bit counters (BC2 to BC0).
- Interrupt factors currently generated (interrupt factors transferred to the interrupt controller).

#### (2) Precautions on Initialization

- Interrupt flags and interrupt factors are not cleared by this function. Thus, you need to clear them own as needed.
- Other register flags are not basically cleared, too. Thus, you need to clear them as needed.
- When this I<sup>2</sup>C is initialized with IICRST bit, write data specified by IICRST bit is maintained. When clearing I<sup>2</sup>C, set IICRST bit once, then clear it using the MOV instruction. The I<sup>2</sup>C cannot operate with the IICRST bit set to 1. Don't try to use bit operation instructions such as BCLR.
- If you try to clear a flag while data sending or receiving is taking place, I<sup>2</sup>C module stops sending or receiving at that moment and frees the SCL and SDA pins. When resuming the communication, initialize registers as needed so that the system communication capability may function as intended.

Clear function of this module does not directly rewrite value of BBSY bit. However, depending on state of SCL and SDA pins and the timing in which they are made free, BBSY bit can be cleared. Other bits and flags can also be affected by status change.

In order to avoid these troubles, the following procedures must be observed in initialization of I<sup>2</sup>C.

- (1) Implement initialization of internal state by setting IICRST bit or ICE bit.
- (2) Execute the stop condition issue instruction (setting BBSY = 0 and SCP = 0 to write) and wait for a duration equivalent to 2 clocks of the transfer rate.
- (3) Execute initialization of internal state again by setting IICRST bit or ICE bit.
- (4) Initialize each I<sup>2</sup>C register (re-setting).

## 25.4 Usage Notes

- (1) In master mode, if an instruction to generate a start condition is immediately followed by an instruction to generate a stop condition, neither condition will be output correctly. To output consecutive start and stop conditions, after issuing the instruction that generates the start condition, read the relevant ports, check that SCL and SDA are both low, then issue the instruction that generates the stop condition. Note that the SCL may briefly remain at a high level immediately after BBSY is cleared to 0.
- (2) Either of the following two conditions will start the next transfer. Pay attention to these conditions when reading or writing to ICDR.
  - (a) Write access to ICDR when ICE = 1 and TRS = 1 (including automatic transfer from ICDRT to ICDRS)
  - (b) Read access to ICDR when ICE = 1 and TRS = 0 (including automatic transfer from ICDRS to ICDRR)
- (3) Table 25.5 shows the timing of SCL and SDA output in synchronization with the internal clock. Timings on the bus are determined by the rise and fall times of signals affected by the bus load capacitance, series resistance, and parallel resistance.

**Table 25.5 I<sup>2</sup>C Bus Timing (SCL and SDA Output)**

Item	Symbol	Output Timing	Unit	Notes
SCL output cycle time	$t_{SCLO}$	28 $t_{cyc}$ to 256 $t_{cyc}$	ns	Figure 29.10 (reference)
SCL output high pulse width	$t_{SCLHO}$	0.5 $t_{SCLO}$	ns	
SCL output low pulse width	$t_{SCLLO}$	0.5 $t_{SCLO}$	ns	
SDA output bus free time	$t_{BUFO}$	0.5 $t_{SCLO}$ - 1 $t_{cyc}$	ns	
Start condition output hold time	$t_{STAHO}$	0.5 $t_{SCLO}$ - 1 $t_{cyc}$	ns	
Retransmission start condition output setup time	$t_{STASO}$	1 $t_{SCLO}$	ns	
Stop condition output setup time	$t_{STOSO}$	0.5 $t_{SCLO}$ + 2 $t_{cyc}$	ns	
Data output setup time (master)	$t_{SDASO}$	1 $t_{SCLLO}$ - 3 $t_{cyc}$	ns	
Data output setup time (slave)		1 $t_{SCLL}$ - (6 $t_{cyc}$ or 12 $t_{cyc}$ *)	ns	
Data output hold time	$t_{SDAHO}$	3 $t_{cyc}$	ns	

Note: \* 6  $t_{cyc}$  when IICX is 0, 12  $t_{cyc}$  when 1.

- (4) SCL and SDA input is sampled in synchronization with the internal clock. The AC timing therefore depends on the system clock cycle  $t_{cyc}$ , as shown in table 29.6. Note that the I<sup>2</sup>C bus interface AC timing specifications will not be met with a system clock frequency of less than 5 MHz.

- (5) The I<sup>2</sup>C bus interface specification for the SCL rise time  $t_{sr}$  is under 1000 ns (300 ns for high-speed mode). In master mode, the I<sup>2</sup>C bus interface monitors the SCL line and synchronizes one bit at a time during communication. If  $t_{sr}$  (the time for SCL to go from low to  $V_{IH}$ ) exceeds the time determined by the input clock of the I<sup>2</sup>C bus interface, the high period of SCL is extended. The SCL rise time is determined by the pull-up resistance and load capacitance of the SCL line. To insure proper operation at the set transfer rate, adjust the pull-up resistance and load capacitance so that the SCL rise time does not exceed the values given in table 25.6.

**Table 25.6 Permissible SCL Rise Time ( $t_{sr}$ ) Values**

IICX	$t_{cyc}$ Indication	Time Indication [ns]				
			I <sup>2</sup> C Bus Specification (Max.)	$\phi = 5$ MHz	$\phi = 8$ MHz	$\phi = 10$ MHz
0	7.5 $t_{cyc}$	Normal mode	1000	←	937	750
		High-speed mode	300	←	←	←
1	17.5 $t_{cyc}$	Normal mode	1000	←	←	←
		High-speed mode	300	←	←	←

- (6) The I<sup>2</sup>C bus interface specifications for the SCL and SDA rise and fall times are under 1000 ns and 300 ns. The I<sup>2</sup>C bus interface SCL and SDA output timing is prescribed by  $t_{Scyc}$  and  $t_{cyc}$ , as shown in table 25.5. However, because of the rise and fall times, the I<sup>2</sup>C bus interface specifications may not be satisfied at the maximum transfer rate. Table 25.7 shows output timing calculations for different operating frequencies, including the worst-case influence of rise and fall times.

$t_{BUFO}$  fails to meet the I<sup>2</sup>C bus interface specifications at any frequency. The solution is either (a) to provide coding to secure the necessary interval (approximately 1  $\mu$ s) between issuance of a stop condition and issuance of a start condition, or (b) to select devices whose input timing permits this output timing for use as slave devices connected to the I<sup>2</sup>C bus.

$t_{SCLLO}$  in high-speed mode and  $t_{STASO}$  in standard mode fail to satisfy the I<sup>2</sup>C bus interface specifications for worst-case calculations of  $t_{sr}/t_{sf}$ . Possible solutions that should be investigated include (a) adjusting the rise and fall times by means of a pull-up resistor and capacitive load, (b) reducing the transfer rate to meet the specifications, or (c) selecting devices whose input timing permits this output timing for use as slave devices connected to the I<sup>2</sup>C bus.

Table 25.7 I<sup>2</sup>C Bus Timing (with Maximum Influence of  $t_{sr}/t_{sr}$ )

Item	$t_{cyc}$ Indication		Time Indication (at Maximum Transfer Rate) [ns]				
			$t_{sr}/t_{sr}$ Influence (Max.)	I <sup>2</sup> C Bus Specification (Min.)	$\phi = 5$ MHz	$\phi = 8$ MHz	$\phi = 10$ MHz
$t_{SCLHO}$	$0.5 t_{SCLO}$ ( $-t_{sr}$ )	Normal mode	-1000	4000	4000	←	←
		High-speed mode	-300	600	950	←	←
$t_{SCLLO}$	$0.5 t_{SCLO}$ ( $-t_{sr}$ )	Normal mode	-250	4700	4750	←	←
		High-speed mode	-250	1300	1000 <sup>*1</sup>	←	←
$t_{BUFO}$	$0.5 t_{SCLO} - 1 t_{cyc}$ ( $-t_{sr}$ )	Normal mode	-1000	4700	3800 <sup>*1</sup>	3875 <sup>*1</sup>	3900 <sup>*1</sup>
		High-speed mode	-300	1300	750 <sup>*1</sup>	825 <sup>*1</sup>	850 <sup>*1</sup>
$t_{STAHO}$	$0.5 t_{SCLO} - 1 t_{cyc}$ ( $-t_{sr}$ )	Normal mode	-250	4000	4550	4625	4650
		High-speed mode	-250	600	800	875	900
$t_{STASO}$	$1 t_{SCLO}$ ( $-t_{sr}$ )	Normal mode	-1000	4700	9000	9000	9000
		High-speed mode	-300	600	2200	2200	2200
$t_{STOSO}$	$0.5 t_{SCLO} + 2 t_{cyc}$ ( $-t_{sr}$ )	Normal mode	-1000	4000	4400	4250	4200
		High-speed mode	-300	600	1350	1200	1150
$t_{SDASO}$ (master)	$1 t_{SCLLO}^{*3} - 3 t_{cyc}$ ( $-t_{sr}$ )	Normal mode	-1000	250	3100	3325	3400
		High-speed mode	-300	100	400	625	700
$t_{SDASO}$ (slave)	$1 t_{SCLL}^{*3} - 12 t_{cyc}^{*2}$ ( $-t_{sr}$ )	Normal mode	-1000	250	1300	2200	2500
		High-speed mode	-300	100	-1400 <sup>*1</sup>	-500 <sup>*1</sup>	-200 <sup>*1</sup>
$t_{SDAHO}$	$3 t_{cyc}$	Normal mode	0	0	600	375	300
		High-speed mode	0	0	↑	↑	↑

Notes: 1. Does not meet the I<sup>2</sup>C bus interface specification. Remedial action such as the following is necessary: (a) secure a start/stop condition issuance interval; (b) adjust the rise and fall times by means of a pull-up resistor and capacitive load; (c) reduce the transfer rate; (d) select slave devices whose input timing permits this output timing.

The values in the above table will vary depending on the settings of the IICX bit and bits CKS2 to CKS0. Depending on the frequency it may not be possible to achieve the maximum transfer rate; therefore, whether or not the I<sup>2</sup>C bus interface specifications are met must be determined in accordance with the actual setting conditions.

- Value when the IICX bit is set to 1. When the IICX bit is cleared to 0, the value is ( $t_{SCLL} - 6 t_{cyc}$ ).
- Calculated using the I<sup>2</sup>C bus specification values (standard mode: 4700 ns min.; high-speed mode: 1300 ns min.).



## (7) Precautions on reading ICDR at the end of master receive mode

When terminating the master receive mode, set TRS bit to 1, and select "write" for ICCR. BBSY = 0 and SCP = 0. This forces to move SDA from low to high level when SCL is at high level, thereby generating the stop condition.

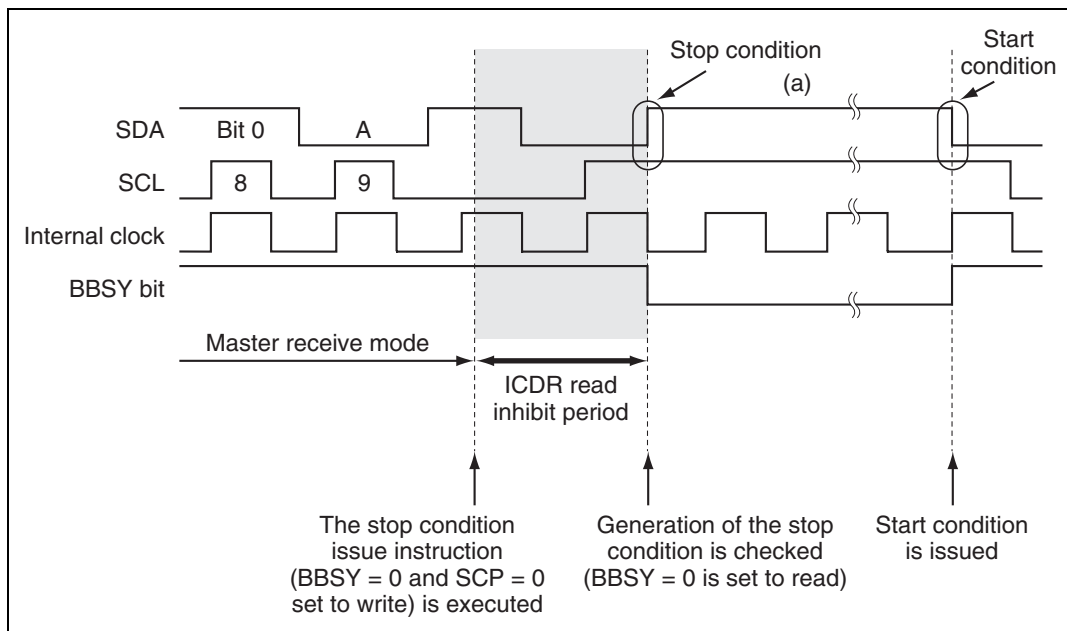
Now you can read received data from ICDR. If, however, any data is remaining on the buffer, received data on ICDRS is not transferred to ICDR, thus you won't be able to read the second byte data.

When it is required to read the second byte data, issue the stop condition from the master receive state (TRS bit is 0).

Before reading data from ICDR register, make sure that BBSY bit on ICCR register is 0, stop condition is generated and bus is made free.

If you try to read received data after the stop condition issue instruction (setting ICCR's BBSY = 0 and SCP = 0 to write) has been executed but before the actual stop condition is generated, clock may not be appropriately signaled when the next master sending mode is turned on. Thus, reasonable care is needed for determining when to read the received data.

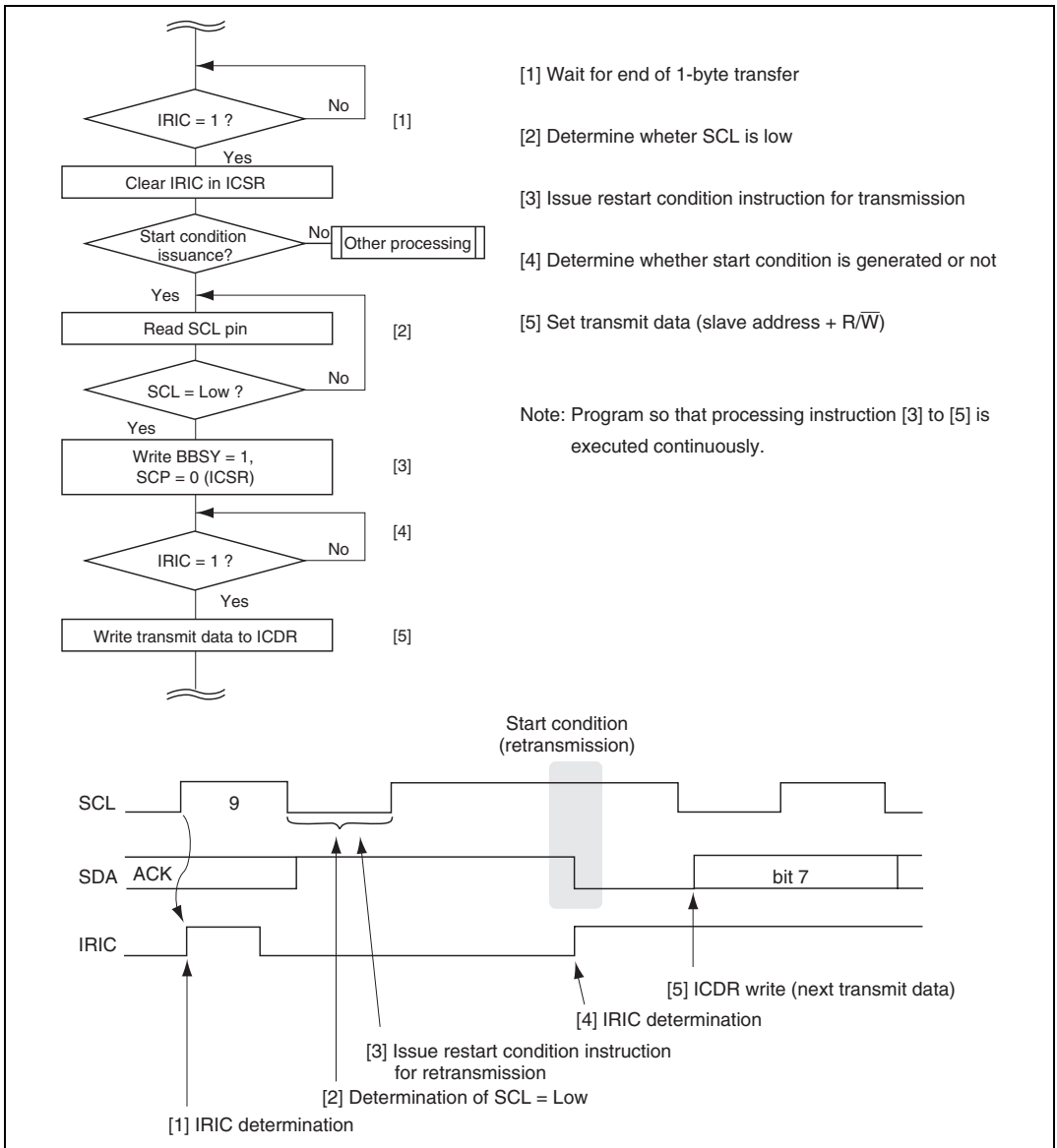
After the master receive is complete, if you want to re-write I<sup>2</sup>C control bit (such as clearing MST bit) for switching the sending/receiving mode or modifying settings, it must be done during period (a) indicated in figure 25.18 (after making sure ICCR register BBSY bit is cleared to 0).



**Figure 25.18 Precautions on Reading the Master Receive Data**

## (8) Notes on start condition issuance for retransmission

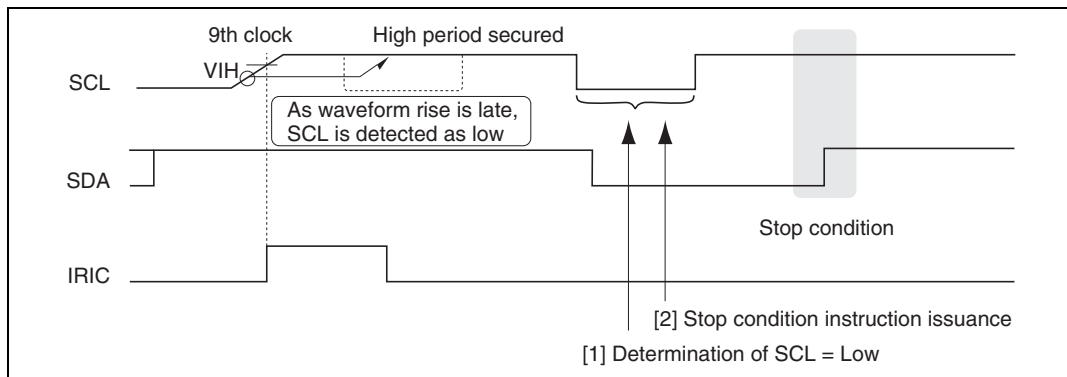
Figure 25.19 shows the timing of start condition issuance for retransmission, and the timing for subsequently writing data to ICDR, together with the corresponding flowchart. After start condition issuance is done and determined the start condition, write the transmit data to ICDR.



**Figure 25.19 Flowchart and Timing of Start Condition Instruction Issuance for Retransmission**

(9) Notes on I<sup>2</sup>C bus interface stop condition issuance

If the rise time of the 9th SCL acknowledge exceeds the specification because the bus load capacitance is large, or if there is a slave device of the type that drives SCL low to effect a wait, issue the stop condition instruction after reading SCL and determining it to be low, as shown below.



**Figure 25.20 Timing of Stop Condition Issuance**

## (10) Notes on WAIT Function

## (a) Conditions to cause this phenomenon

When both of the following conditions are satisfied, the clock pulse of the 9th clock could be outputted continuously in master mode using the WAIT function due to the failure of the WAIT insertion after the 8th clock fall.

- (1) Setting the WAIT bit of the ICMR register to 1 and operating WAIT, in master mode
- (2) If the IRIC bit of interrupt flag is cleared from 1 to 0 between the fall of the 7th clock and the fall of the 8th clock.

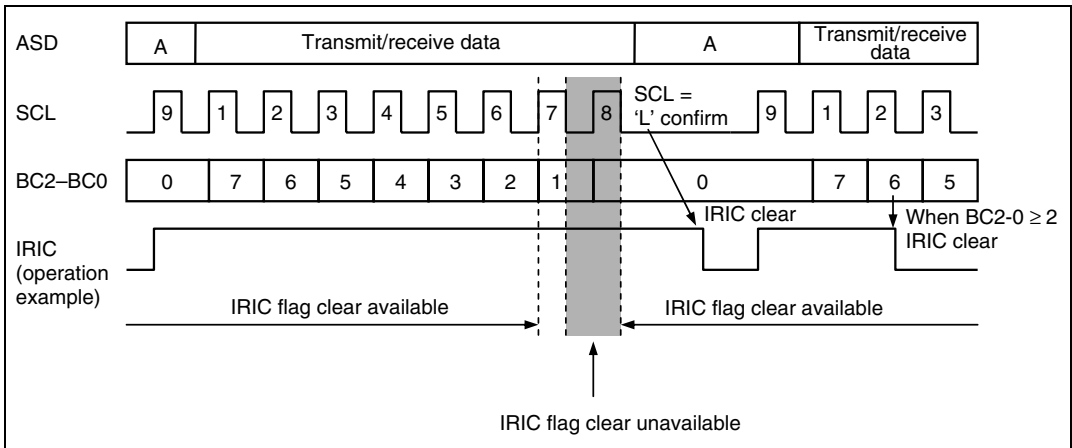
## (b) Error phenomenon

Normally, WAIT State will be cancelled by clearing the IRIC flag bit from 1 to 0 after the fall of the 8th clock in WAIT State. In this case, if the IRIC flag bit is cleared between the 7th clock fall and the 8th clock fall, the IRIC flag clear- data will be retained internally. Therefore, the WAIT State will be cancelled right after WAIT insertion on 8th clock fall.

## (c) Restrictions

Please clear the IRIC flag before the rise of the 7th clock (the counter value of BC2 through BC0 should be 2 or greater), after the IRIC flag is set to 1 on the rise of the 9th clock.

If the IRIC flag-clear is delayed due to the interrupt or other processes and the value of BC counter is turned to 1 or 0, please confirm the SCL pins are in L' state after the counter value of BC2 through BC0 is turned to 0, and clear the IRIC flag. (See figure 25.21.)



**Figure 25.21 IRIC Flag Clear Timing on WAIT Operation**

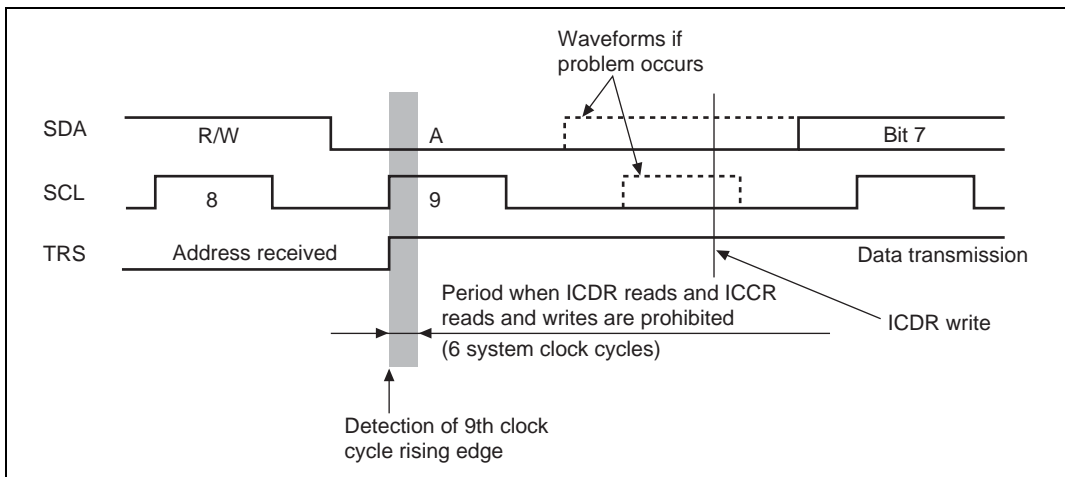
#### (11) Notes on ICDR Reads and ICCR Access in Slave Transmit Mode

In a transmit operation in the slave mode of the I<sup>2</sup>C bus interface, do not read the ICDR register or read or write to the ICCR register during the period indicated by the shaded portion in figure 25.22.

Normally, when interrupt processing is triggered in synchronization with the rising edge of the 9th clock cycle, the period in question has already elapsed when the transition to interrupt processing takes place, so there is no problem with reading the ICDR register or reading or writing to the ICCR register.

To ensure that the interrupt processing is performed properly, one of the following two conditions should be applied.

- (1) Make sure that reading received data from the ICDR register, or reading or writing to the ICCR register, is completed before the next slave address receive operation starts.
- (2) Monitor the BC2 to BC0 counter in the ICMR register and, when the value of BC2 to BC0 is 000 (8th or 9th clock cycle), allow a waiting time of at least 2 transfer clock cycles in order to involve the problem period in question before reading from the ICDR register, or reading or writing to the ICCR register.



**Figure 25.22 ICDR Read and ICCR Access Timing in Slave Transmit Mode**

#### (12) Notes on TRS Bit Setting in Slave Mode

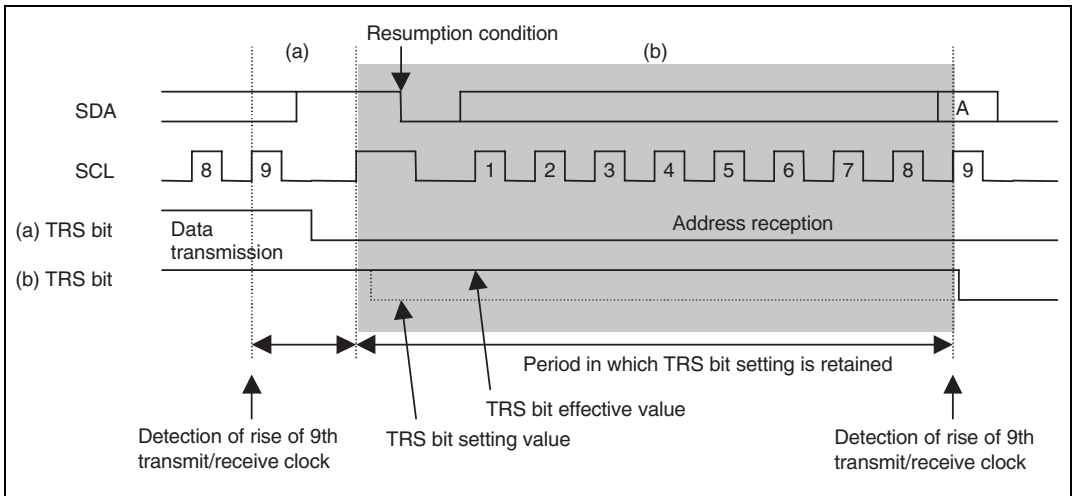
From the detection of the rising edge of the 9th clock cycle or of a stop condition to when the rising edge of the next SCL pin signal is detected (the period indicated as (a) in figure 25.23) in the slave mode of the I<sup>2</sup>C bus interface, the value set in the TRS bit in the ICCR register is effective immediately.

However, at other times (indicated as (b) in figure 25.23) the value set in the TRS bit is put on hold until the next rising edge of the 9th clock cycle or stop condition is detected, rather than taking effect immediately.

This results in the actual internal value of the TRS bit remaining 1 (transmit mode) and no acknowledge bit being sent at the 9th clock cycle address receive completion in the case of an address receive operation following a restart condition input with no stop condition intervening.

When receiving an address in the slave mode, clear the TRS bit to 0 during the period indicated as (a) in figure 25.23.

To cancel the holding of the SCL bit low by the wait function in the slave mode, clear the TRS bit to 0 and then perform a dummy read of the ICDR register.



**Figure 25.23 TRS Bit Setting Timing in Slave Mode**

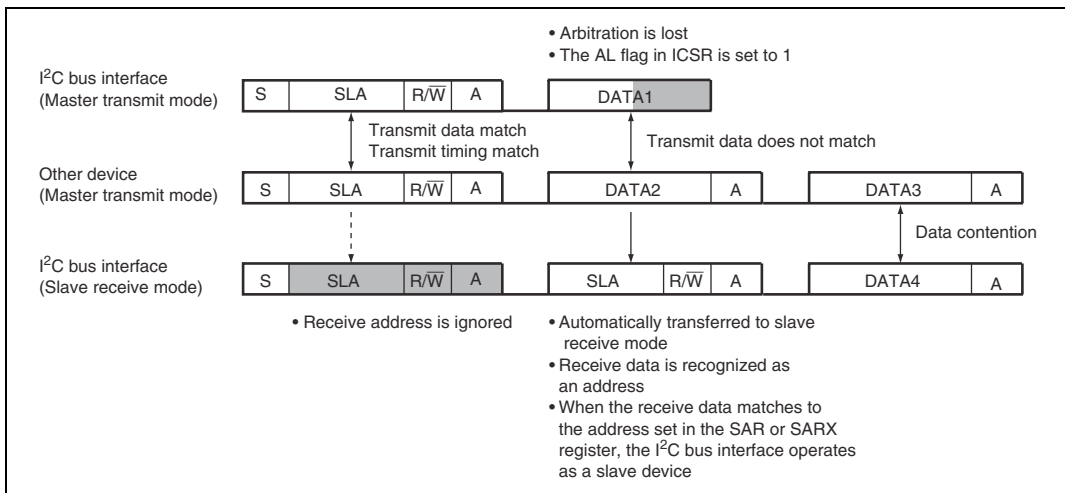
### (13) Notes on Arbitration Lost in Master Mode

The I<sup>2</sup>C bus interface recognizes the data in transmit/receive frame as an address when arbitration is lost in master mode and a transition to slave receive mode is automatically carried out.

When arbitration is lost not in the first frame but in the second frame or subsequent frame, transmit/receive data that is not an address is compared with the value set in the SAR or SARX register as an address. If the receive data matches with the address in the SAR or SARX register, the I<sup>2</sup>C bus interface erroneously recognizes that the address call has occurred. (See figure 25.24.)

In multi-master mode, a bus conflict could happen. When The I<sup>2</sup>C bus interface is operated in master mode, check the state of the AL bit in the ICSR register every time after one frame of data has been transmitted or received.

When arbitration is lost during transmitting the second frame or subsequent frame, take avoidance measures.



**Figure 25.24 Diagram of Erroneous Operation when Arbitration is Lost**

Though it is prohibited in the normal I<sup>2</sup>C protocol, the same problem may occur when the MST bit is erroneously set to 1 and a transition to master mode is occurred during data transmission or reception in slave mode. In multi-master mode, pay attention to the setting of the MST bit when a bus conflict may occur. In this case, the MST bit in the ICCR register should be set to 1 according to the order below.

- (a) Make sure that the BBSY flag in the ICCR register is 0 and the bus is free before setting the MST bit.
- (b) Set the MST bit to 1.
- (c) To confirm that the bus was not entered to the busy state while the MST bit is being set, check that the BBSY flag in the ICCR register is 0 immediately after the MST bit has been set.

#### (14) Notes on Interrupt Occurrence after ACKB Reception

— Conditions to cause this failure

The IRIC flag is set to 1 when both of the following conditions are satisfied.

- 1 is received as the acknowledge bit for transmit data and the ACKB bit in ICSR is set to 1
- Rising edge of the 9th transmit/receive clock is input to the SCL pin

When the above two conditions are satisfied in slave receive mode, an unnecessary interrupt occurs.

Figure 25.25 shows the note on interrupt occurrence in slave mode after receiving 1 as the acknowledge bit (ACKB = 1).

(1) For the last transmit data in master transmit mode or slave transmit mode, 1 is received as the acknowledge bit.

If the ACKE bit in ICCR is set to 1 at this time, the ACKB bit in ICSR is set to 1.

(2) After switching to slave receive mode, the start condition is input, and address reception is performed next.

(3) Even if the received address does not match the address set in SAR or SARX, the IRIC flag is set to 1 at the rise of the 9th transmit/receive clock, thus causing an interrupt to occur.

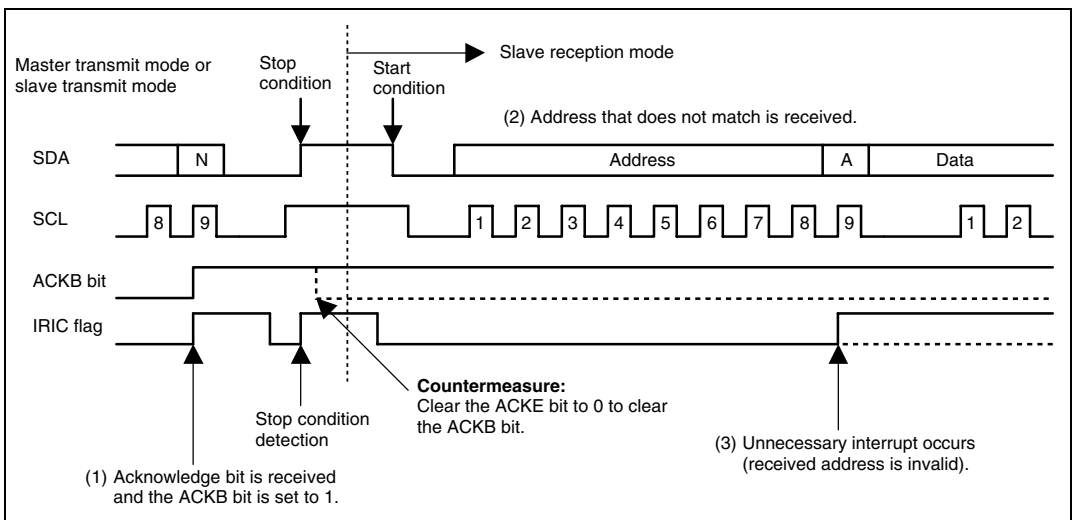
Note that if the slave address matches, an interrupt is to be generated at the rise of the 9th transmit/receive clock as normal operation, so this is not erroneous operation.

#### — Restriction

In a transmit operation of the I<sup>2</sup>C bus interface module, carry out the following countermeasures.

(1) After 1 is received as the acknowledge bit for transmit data, clear the ACKE bit in ICCR to 0 to clear the ACKB bit to 0.

(2) To enable acknowledge bit reception afterwards, set the ACKE bit to 1 again.



**Figure 25.25 Note on Interrupt Occurrence in Slave Mode after ACKB = 1 Reception**



## (15) Notes on TRS Bit Setting and ICDR Register Access

Conditions to cause this failure

Low-fixation of the SCL pins is cancelled incorrectly when the following conditions are satisfied.

— Master mode

Figure 25.26 shows the notes on ICDR reading (TRS = 1) in master mode.

- (1) When previously received 2-bytes data remains in ICDR unread (ICDRS are full).
- (2) Reads ICDR register after switching to transmit mode (TRS = 1). (RDRF = 0 state)
- (3) Sets to receive mode (TRS = 0), after transmitting Rev.1 frame of issued start condition by master mode.

— Slave mode

Figure 25.27 shows the notes on ICDR writing (TRS = 0) in slave mode.

- (1) Writes ICDR register in receive mode (TRS = 0), after entering the start condition by slave mode (TDRE = 0 state).

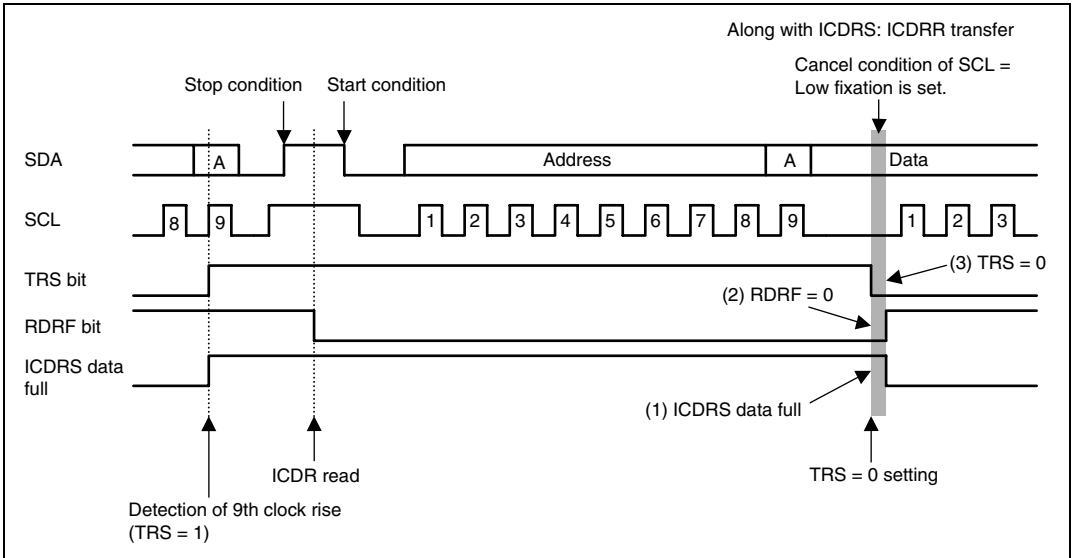
Address match with Rev.1 frame, receive 1 by R/W bit, and switches to transmit mode (TRS = 1).

When these conditions are satisfied, the low fixation of the SCL pins is cancelled without ICDR register access after Rev.1 frame is transferred.

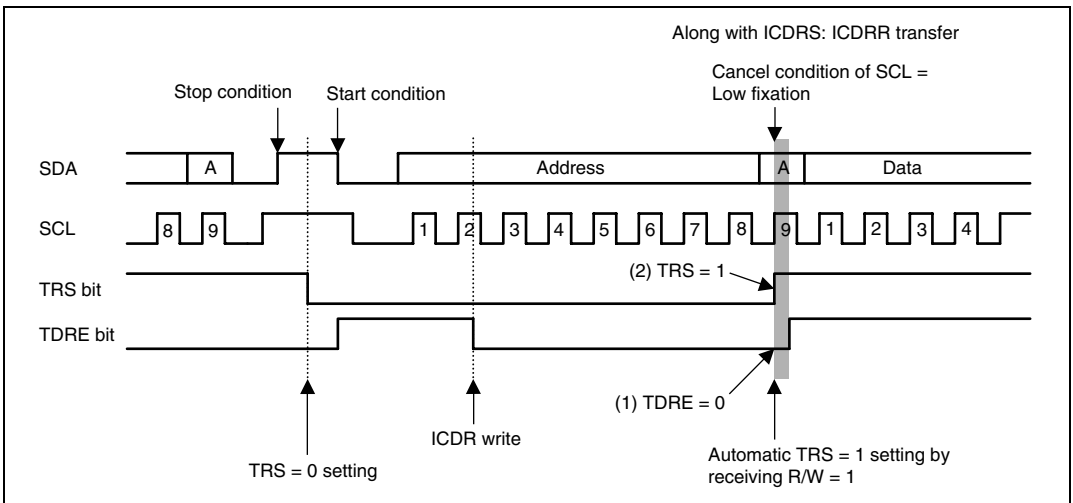
— Restriction

Please carry out the following countermeasures when transmitting/receiving via the IIC bus interface module.

- (1) Please read the ICDR registers in receive mode, and write them in transmit mode.
- (2) In receiving operation with master mode, please issue the start condition after clearing the internal flag of the IIC bus interface module, using CLR3 to CLR0 bit of the DDSCSWR register on bus-free state (BBSY = 0).



**Figure 25.26 Notes on ICDR Reading with TRS = 1 Setting in Master Mode**



**Figure 25.27 Notes on ICDR Writing with TRS = 0 Setting in Slave Mode**

## Section 26 A/D Converter

### 26.1 Overview

This LSI incorporates a 10-bit successive-approximations A/D converter that allows up to 12 analog input channels to be selected.

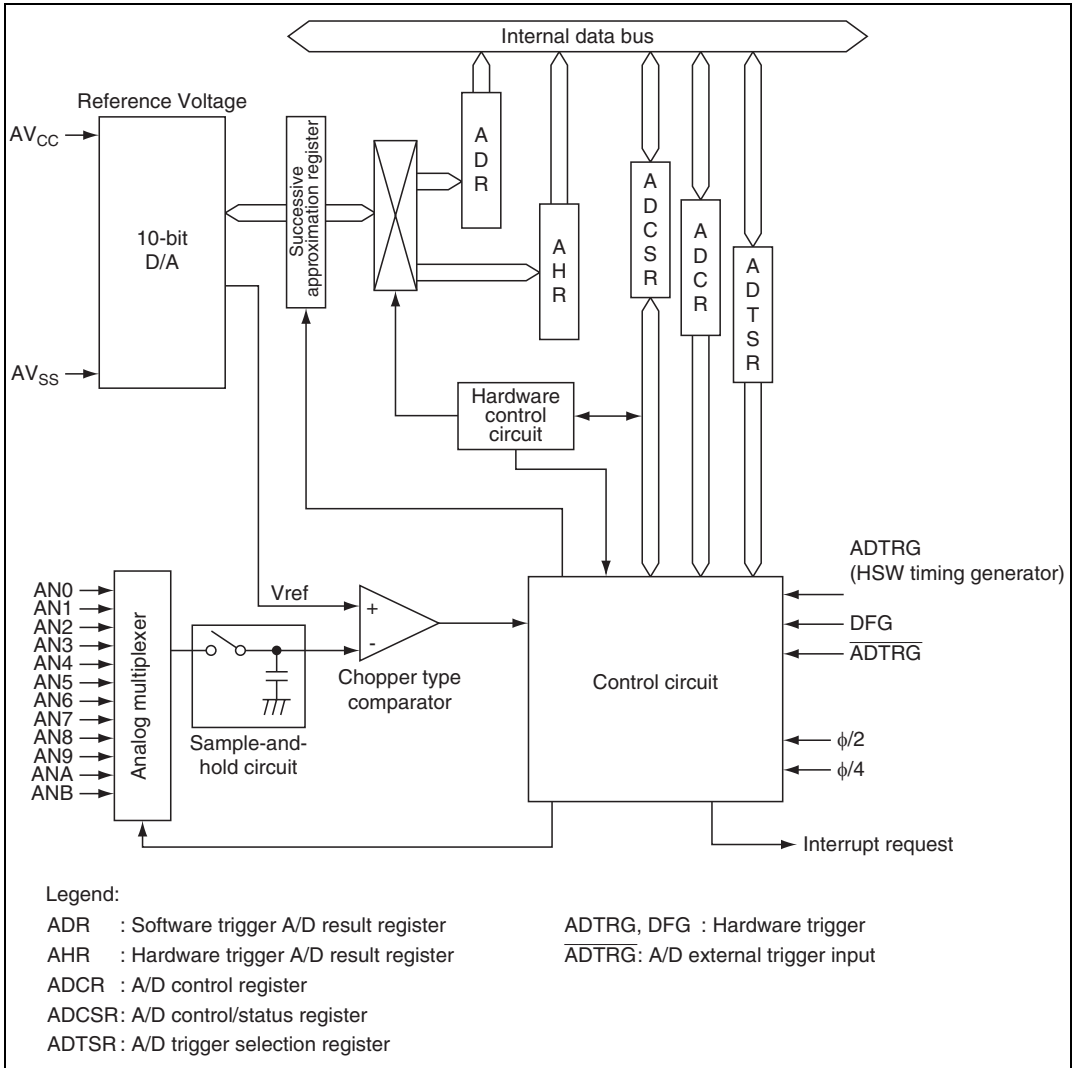
#### 26.1.1 Features

A/D converter features are listed below.

- 10-bit resolution
- 12 input channels
- Sample and hold function
- Choice of software, hardware (internal signal) triggering, or external triggering for A/D conversion start.
- A/D conversion end interrupt request generation

## 26.1.2 Block Diagram

Figure 26.1 shows a block diagram of the A/D converter.



**Figure 26.1 Block Diagram of A/D Converter**

### 26.1.3 Pin Configuration

Table 26.1 summarizes the input pins used by the A/D converter.

**Table 26.1 A/D Converter Pins**

<b>Name</b>	<b>Abbrev.</b>	<b>I/O</b>	<b>Function</b>
Analog power supply pin	$AV_{cc}$	Input	Analog block power supply
Analog ground pin	$AV_{ss}$	Input	Analog block ground and A/D conversion reference voltage
Analog input pin 0	AN0	Input	Analog input channel 0
Analog input pin 1	AN1	Input	Analog input channel 1
Analog input pin 2	AN2	Input	Analog input channel 2
Analog input pin 3	AN3	Input	Analog input channel 3
Analog input pin 4	AN4	Input	Analog input channel 4
Analog input pin 5	AN5	Input	Analog input channel 5
Analog input pin 6	AN6	Input	Analog input channel 6
Analog input pin 7	AN7	Input	Analog input channel 7
Analog input pin 8	AN8	Input	Analog input channel 8
Analog input pin 9	AN9	Input	Analog input channel 9
Analog input pin A	ANA	Input	Analog input channel A
Analog input pin B	ANB	Input	Analog input channel B
A/D external trigger input pin	$\overline{ADTRG}$	Input	External trigger input for starting A/D conversion

### 26.1.4 Register Configuration

Table 26.2 summarizes the registers of the A/D converter.

**Table 26.2 A/D Converter Registers**

<b>Name</b>	<b>Abbrev.</b>	<b>R/W</b>	<b>Size</b>	<b>Initial Value</b>	<b>Address<sup>*2</sup></b>
Software trigger A/D result register H	ADRH	R	Byte	H'00	H'D130
Software trigger A/D result register L	ADRL	R	Byte	H'00	H'D131
Hardware trigger A/D result register H	AHRH	R	Byte	H'00	H'D132
Hardware trigger A/D result register L	AHRL	R	Byte	H'00	H'D133
A/D control register	ADCR	R/W	Byte	H'40	H'D134
A/D control/status register	ADCSR	R (W) <sup>*1</sup>	Byte	H'01	H'D135
A/D trigger selection register	ADTSR	R/W	Byte	H'FC	H'D136
Port mode register 0	PMR0	R/W	Byte	H'00	H'FFCD

Notes: 1. Only 0 can be written in bits 7 and 6, to clear the flag. Bits 3 to 1 are read-only.  
 2. Lower 16 bits of the address.

## 26.2 Register Descriptions

### 26.2.1 Software-Triggered A/D Result Register (ADR)

Bit :	ADRH								ADRL							
	15	14	13	12	11	10	9	8	7	6	5	4	3	2	1	0
	ADR9	ADR8	ADR7	ADR6	ADR5	ADR4	ADR3	ADR2	ADR1	ADR0	—	—	—	—	—	—
Initial value :	0	0	0	0	0	0	0	0	0	0	0	0	0	0	0	0
R/W :	R	R	R	R	R	R	R	R	R	R	—	—	—	—	—	—

The software-triggered A/D result register (ADR) is a register that stores the result of an A/D conversion started by software.

The A/D-converted data is 10-bit data. Upon completion of software-triggered A/D conversion, the 10-bit result data is transferred to ADR and the data is retained until the next software-triggered A/D conversion completion. The upper 8 bits of the data are stored in the upper bytes (bits 15 to 8) of ADR, and the lower 2 bits are stored in the lower bytes (bits 7 and 6). Bits 5 to 0 are always read as 0.

ADR can be read by the CPU at any time, but the ADR value during A/D conversion is not fixed. The upper bytes can always be read directly, but the data in the lower bytes is transferred via a temporary register (TEMP). For details, see section 26.3, Interface to Bus Master.

ADR is a 16-bit read-only register which is initialized to H'0000 at a reset, and in module stop mode, standby mode, watch mode, subactive mode and subsleep mode.

### 26.2.2 Hardware-Triggered A/D Result Register (AHR)

Bit :	AHRH								AHLR							
	15	14	13	12	11	10	9	8	7	6	5	4	3	2	1	0
	AHR9	AHR8	AHR7	AHR6	AHR5	AHR4	AHR3	AHR2	AHR1	AHR0	—	—	—	—	—	—
Initial value :	0	0	0	0	0	0	0	0	0	0	0	0	0	0	0	0
R/W :	R	R	R	R	R	R	R	R	R	R	—	—	—	—	—	—

The hardware-triggered A/D result register (AHR) is a register that stores the result of an A/D conversion started by hardware (internal signal: ADTRG and DFG) or by external trigger input (ADTRG).

The A/D-converted data is 10-bit data. Upon completion of hardware- or external-triggered A/D conversion, the 10-bit result data is transferred to AHR and the data is retained until the next hardware- or external- triggered A/D conversion completion. The upper 8 bits of the data are stored in the upper bytes (bits 15 to 8) of AHR, and the lower 2 bits are stored in the lower bytes (bits 7 and 6). Bits 5 to 0 are always read as 0.

AHR can be read by the CPU at any time, but the AHR value during A/D conversion is not fixed. The upper bytes can always be read directly, but the data in the lower bytes is transferred via a temporary register (TEMP). For details, see section 26.3, Interface to Bus Master. AHR is a 16-bit read-only register which is initialized to H'0000 at a reset, and in module stop mode, standby mode, watch mode, subactive mode and subsleep mode.

### 26.2.3 A/D Control Register (ADCR)

Bit :	7	6	5	4	3	2	1	0
	CK	—	HCH1	HCH0	SCH3	SCH2	SCH1	SCH0
Initial value :	0	1	0	0	0	0	0	0
R/W :	R/W	—	R/W	R/W	R/W	R/W	R/W	R/W

ADCR is a register that sets A/D conversion speed and selects analog input channel. When executing ADCR setting, make sure that the SST and HST flags in ADCSR is set to 0.

ADCR is an 8-bit readable/writable register that is initialized to H'40 by a reset, and in module stop mode, standby mode, watch mode, subactive mode and subsleep mode.

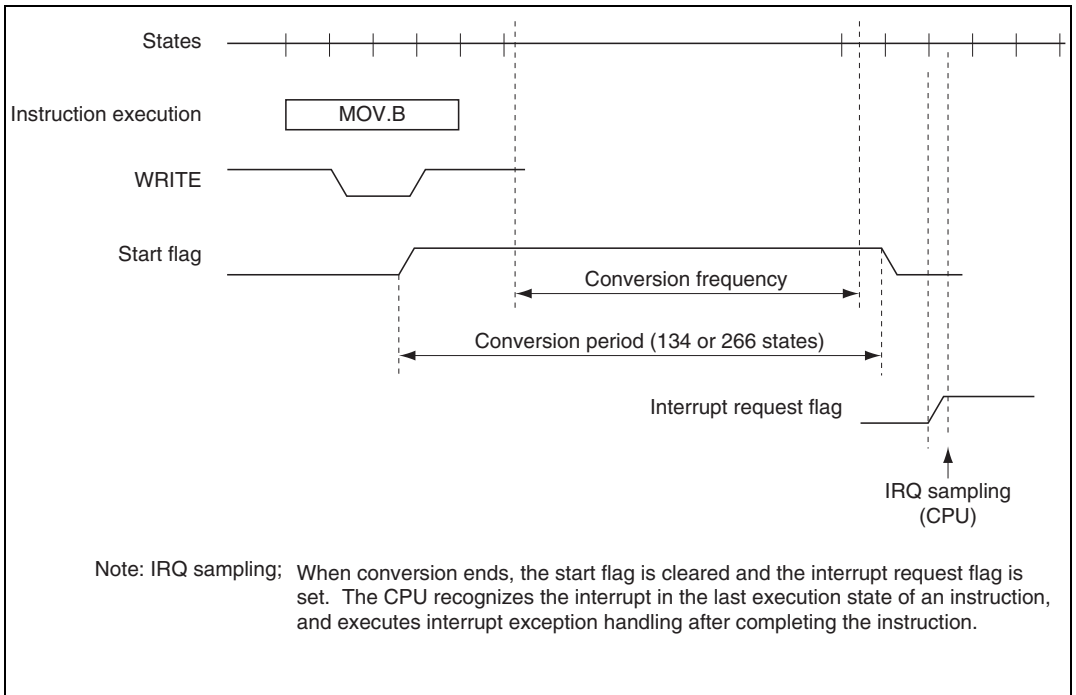
**Bit 7—Clock Select (CK):** Sets A/D conversion speed.

#### Bit 7

CK	Description
0	Conversion frequency is 266 states (Initial value)
1	Conversion frequency is 134 states

Note: A/D conversion starts when 1 is written in SST, or when HST is set to 1. The conversion period is the time from when this start flag is set until the flag is cleared at the end of conversion. Actual sample-and-hold takes place (repeatedly) during the conversion frequency shown in figure 26.2.





**Figure 26.2 Internal Operation of A/D Converter**

**Bit 6—Reserved:** This bit cannot be modified and always reads 1. Writes are disabled.

**Bits 5 and 4—Hardware Channel Select (HCH1, HCH0):** These bits select the analog input channel that is converted by hardware triggering or triggering by an external input. Only channels AN8 to ANB are available for hardware- or external-triggered conversion.

Bit 5	Bit 4	Analog Input Channel	
HCH1	HCH0		
0	0	AN8	(Initial value)
	1	AN9	
1	0	ANA	
	1	ANB	

**Bits 3 to 0—Software Channel Select (SCH3 to SCH0)**

These bits select the analog input channel that is converted by software triggering.

When channels AN0 to AN7 are used, appropriate pin settings must be made in port mode register 0 (PMR0). For pin settings, see section 26.2.6, Port Mode Register 0 (PMR0).

Bit 3	Bit 2	Bit 1	Bit 0	Analog Input Channel
SCH3	SCH2	SCH1	SCH0	
0	0	0	0	AN0 (Initial value)
			1	AN1
		1	0	AN2
			1	AN3
	1	0	0	AN4
			1	AN5
		1	0	AN6
			1	AN7
1	0	0	0	AN8
			1	AN9
	1	0	0	ANA
			1	ANB
	1	*	*	No channel selected for software-triggered conversion

Legend: \* Don't care.

Note: If conversion is started by software when SCH3 to SCH0 are set to 11\*\*, the conversion result is undetermined. Hardware- or external-triggered conversion, however, will be performed on the channel selected by HCH1 and HCH0.

## 26.2.4 A/D Control/Status Register (ADCSR)

Bit :	7	6	5	4	3	2	1	0
	SEND	HEND	ADIE	SST	HST	BUSY	SCNL	—
Initial value :	0	0	0	0	0	0	0	1
R/W :	R/(W)*	R/(W)*	R/W	R/W	R	R	R	—

Note: \* Only 0 can be written to bits 7 and 6, to clear the flag.

The A/D status register (ADCSR) is an 8-bit register that can be used to start or stop A/D conversion, or check the status of the A/D converter.

A/D conversion starts when 1 is written in SST flag. A/D conversion can also start by setting HST flag to 1 by hardware- or external-triggering.

For ADTRG start by HSW timing generator in hardware triggering, see section 28.4, HSW (Head-Switch) Timing Generator.

When conversion ends, the converted data is stored in the software-triggered A/D result register (ADR) or hardware-triggered A/D result register (AHR), and the SST or HST bit is cleared to 0. If software-triggering and hardware- or external-triggering are generated at the same time, priority is given to hardware- or external-triggering.

ADCSR is an 8-bit register which is initialized to H'01 by a reset, and in module stop mode, standby mode, watch mode, subactive mode and subsleep mode.

**Bit 7—Software A/D End Flag (SEND):** Indicates the end of A/D conversion.

### Bit 7

SEND	Description
0	[Clearing Condition] 0 is written after reading 1 (Initial value)
1	[Setting Condition] Software-triggered A/D conversion has ended

**Bit 6—Hardware A/D End Flag (HEND):** Indicates that hardware- or external-triggered A/D conversion has ended.

**Bit 6**

HEND	Description
0	[Clearing Condition] (Initial value) 0 is written after reading
1	[Setting Condition] Hardware- or external-triggered A/D conversion has ended

**Bit 5—A/D Interrupt Enable (ADIE):** Selects enable or disable of interrupt (ADI) generation upon A/D conversion end.

**Bit 5**

ADIE	Description
0	Interrupt (ADI) upon A/D conversion end is disabled (Initial value)
1	Interrupt (ADI) upon A/D conversion end is enabled

**Bit 4—Software A/D Start Flag (SST):** Starts software-triggered A/D conversion and indicates or controls the end of conversion. This bit remains 1 during software-triggered A/D conversion. When 0 is written in this bit, software-triggered A/D conversion operation can forcibly be aborted.

**Bit 4**

SST	Description
0	Read: Indicates that software-triggered A/D conversion has ended or been stopped (Initial value) Write: Software-triggered A/D conversion is aborted
1	Read: Indicates that software-triggered A/D conversion is in progress Write: Starts software-triggered A/D conversion

**Bit 3—Hardware A/D Status Flag (HST):** Indicates the status of hardware- or external-triggered A/D conversion. When 0 is written in this bit, A/D conversion is aborted regardless of whether it was hardware-triggered or external-triggered.

**Bit 3**

<b>HST</b>	<b>Description</b>
0	Read: Hardware- or external-triggered A/D conversion is not in progress(Initial value) Write: Hardware- or external-triggered A/D conversion is aborted.
1	Hardware- or external-triggered A/D conversion is in progress.

**Bit 2—Busy Flag (BUSY):** During hardware- or external-triggered A/D conversion, if software attempts to start A/D conversion by writing to the SST bit, the SST bit is not modified and instead the BUSY flag is set to 1.

This flag is cleared when the hardware-triggered A/D result register (AHR) is read.

**Bit 2**

<b>BUSY</b>	<b>Description</b>
0	No contention for A/D conversion (Initial value)
1	Indicates an attempt to execute software-triggered A/D conversion while hardware- or external-triggered A/D conversion was in progress

**Bit 1—Software-Triggered Conversion Cancel Flag (SCNL):** Indicates that software-triggered A/D conversion was canceled by the start of hardware-triggered A/D conversion.

This flag is cleared when A/D conversion is started by software.

**Bit 1**

<b>SCNL</b>	<b>Description</b>
0	No contention for A/D conversion (Initial value)
1	Indicates that software-triggered A/D conversion was canceled by the start of hardware-triggered A/D conversion

**Bit 0—Reserved:** This bit cannot be modified and always reads 1. Writes are disabled.

### 26.2.5 Trigger Select Register (ADTSR)

Bit :	7	6	5	4	3	2	1	0
	—	—	—	—	—	—	TRGS1	TRGS0
Initial value :	1	1	1	1	1	1	0	0
R/W :	—	—	—	—	—	—	R/W	R/W

The trigger select register (ADTSR) selects hardware- or external-triggered A/D conversion start factor.

ADTSR is an 8-bit readable/writable register that is initialized to H'FC by a reset, and in module stop mode, standby mode, watch mode, subactive mode and subsleep mode.

**Bits 7 to 2—Reserved:** These bits are reserved and are always read as 1. Writes are disabled.

**Bits 1 and 0—Trigger Select:** These bits select hardware- or external-triggered A/D conversion start factor. Set these bits when A/D conversion is not in progress.

Bit 1	Bit 0	Description
TRGS1	TRGS0	
0	0	Hardware- or external-triggered A/D conversion is disabled (Initial value)
	1	Hardware-triggered (ADTRG) A/D conversion is selected
1	0	Hardware-triggered (DFG) A/D conversion is selected
	1	External-triggered ( $\overline{\text{ADTRG}}$ ) A/D conversion is selected

### 26.2.6 Port Mode Register 0 (PMR0)

Bit :	7	6	5	4	3	2	1	0
	PMR07	PMR06	PMR05	PMR04	PMR03	PMR02	PMR01	PMR00
Initial value :	0	0	0	0	0	0	0	0
R/W :	R/W	R/W	R/W	R/W	R/W	R/W	R/W	R/W

Port mode register 0 (PMR0) controls switching of each pin function of port 0. Switching is specified for each bit.

PMR0 is an 8-bit readable/writable register and is initialized to H'00 by a reset.

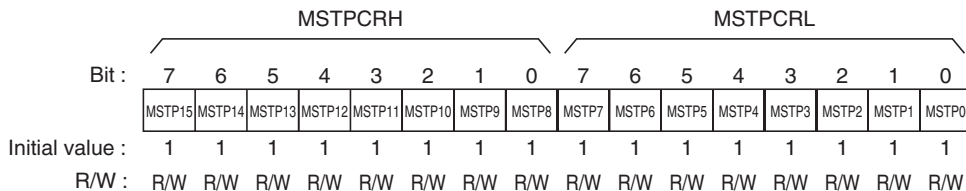
**Bits 7 to 0—P07/AN7 to P00/AN0 pin switching (PMR07 to PMR00):** These bits set the P0n/ANn pin as the input pin for P0n or as the ANn pin for A/D conversion analog input channel.

**Bit n**

PMR0n	Description
0	P0n/ANn functions as a general-purpose input port (Initial value)
1	P0n/ANn functions as an analog input channel

Note: n = 7 to 0

## 26.2.7 Module Stop Control Register (MSTPCR)



MSTPCR consists of 8-bit readable/writable registers and performs module stop mode control. When the MSTP2 bit in MSTPCR is set to 1, A/D converter operation stops at the end of the bus cycle and a transition is made to module stop mode. For details, see section 4.5, Module Stop Mode.

MSTPCR is initialized to H'FFFF by a reset

**Bit 2—Module Stop (MSTP2):** Specifies the A/D converter module stop mode.

### MSTPCRL

**Bit 2**

MSTP2	Description
0	A/D converter module stop mode is cleared
1	A/D converter module stop mode is set (Initial value)

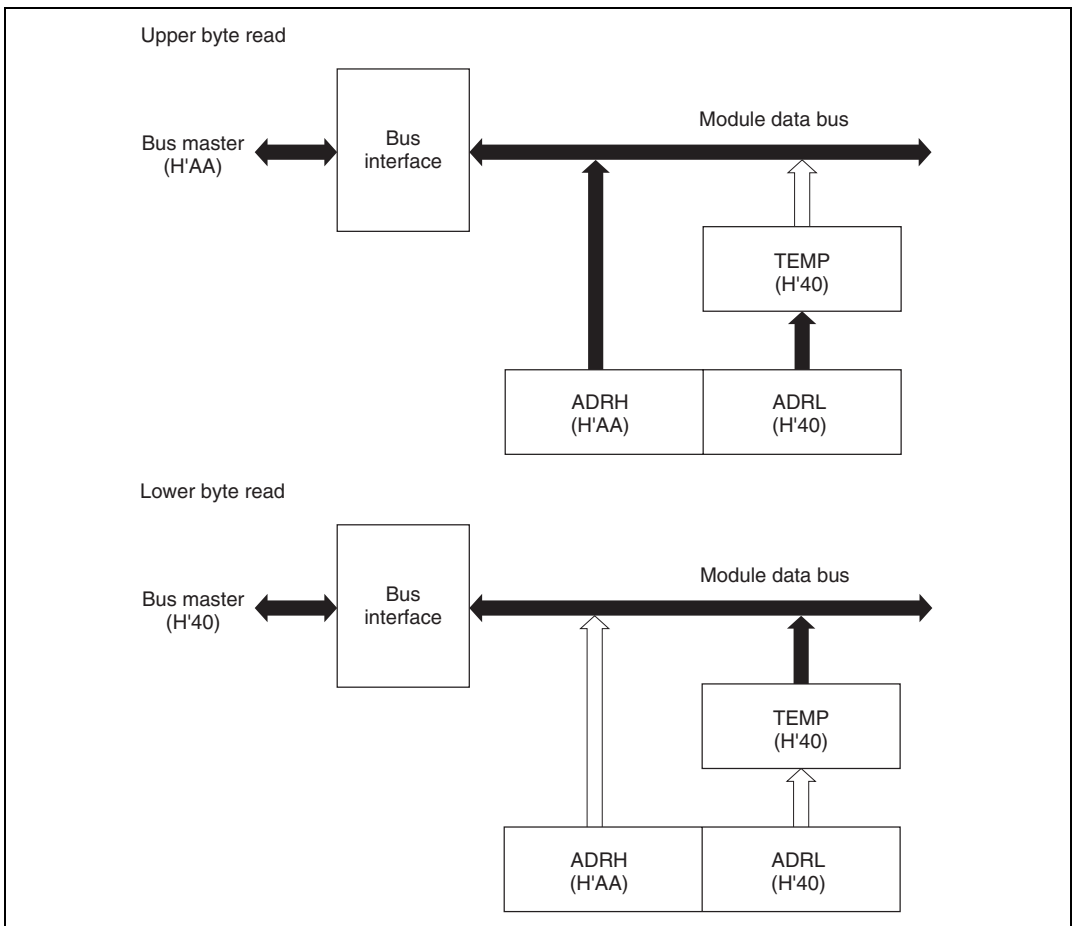
## 26.3 Interface to Bus Master

ADR and AHR are 16-bit registers, but the data bus to the bus master is only 8 bits wide. Therefore, in accesses by the bus master, the upper byte is accessed directly, but the lower byte is accessed via a temporary register (TEMP).

A data reading from ADR and AHR is performed as follows. When the upper byte is read, the upper byte value is transferred to the CPU and the lower byte value is transferred to TEMP. Next, when the lower byte is read, the TEMP contents are transferred to the CPU.

When reading ADR and AHR, always read the upper byte before the lower byte. It is possible to read only the upper byte, but if only the lower byte is read, incorrect data may be obtained.

Figure 26.3 shows the data flow for ADR access. The data flow for AHR access is the same.



**Figure 26.3 ADR Access Operation (Reading H'AA40)**



## 26.4 Operation

The A/D converter operates by successive approximations with 10-bit resolution.

### 26.4.1 Software-Triggered A/D Conversion

A/D conversion starts when software sets the software A/D start flag (SST bit) to 1. The SST bit remains set to 1 during A/D conversion, and is automatically cleared to 0 when conversion ends. Conversion can be software-triggered on any of the 12 channels provided by analog input pins AN0 to ANB. Bits SCH3 to SCH0 in ADCR select the analog input pin used for software-triggered A/D conversion. Pins AN8 to ANB are also available for hardware- or external-triggered conversion.

When conversion ends, SEND flag in ADCSR bit is set to 1. If ADIE bit in ADCSR is also set to 1, an A/D conversion end interrupt occurs.

If the conversion time or input channel selection in ADCR needs to be changed during A/D conversion, to avoid malfunctions, first clear the SST bit to 0 to halt A/D conversion.

If software writes 1 in the SST bit to start software-triggered conversion while hardware- or external-triggered conversion is in progress, the hardware- or external-triggered conversion has priority and the software-triggered conversion is not executed. At this time, BUSY flag in ADCSR is set to 1. The BUSY flag is cleared to 0 when the hardware-triggered A/D result register (AHR) is read. If conversion is triggered by hardware while software-triggered conversion is in progress, the software-triggered conversion is immediately canceled and the SST flag is cleared to 0, and SCNL flag in ADCSR is set to 1. The SCNL flag is cleared when software writes 1 in the SST bit to start conversion after the hardware-triggered conversion ends.

### 26.4.2 Hardware- or External-Triggered A/D Conversion

The system contains the hardware trigger function that allows to turn on A/D conversion at a specified timing by use of the hardware trigger (internal signals: ADTRG and DFG) and the incoming external trigger ( $\overline{\text{ADTRG}}$ ). This function can be used to measure an analog signal that varies in synchronization with an external signal at a fixed timing.

To execute hardware- or external-triggered A/D conversion, select appropriate start factor in TRGS1 and TRGS0 bits in ADTSR. When the selected triggering occurs, HST flag in ADCSR is set to 1 and A/D conversion starts. The HST flag remains 1 during A/D conversion, and is automatically cleared to 0 when conversion ends. For ADTRG start by HSW timing generator in hardware triggering, see section 28.4, HSW (Head-Switch) Timing Generator. Setting of the analog input pins on four channels from AN8 to ANB can be modified with the hardware trigger or the incoming external trigger. Setting is done from HCH1 and HCH0 bits on ADCR. Pins AN8 to ANB are also available for software-triggered conversion.

When conversion ends, HEND flag in ADCSR is set to 1. If ADIE bit in ADCSR is also set to 1, an A/D conversion end interrupt occurs.

If the conversion time or input channel selection in ADCR needs to be changed during A/D conversion, to avoid malfunctions, first clear the HST flag to 0 to halt A/D conversion.

If software writes 1 in the SST bit to start software-triggered conversion while hardware- or external-triggered conversion is in progress, the hardware- or external-triggered conversion has priority and the software-triggered conversion is not executed. At this time, BUSY flag in ADCSR is set to 1. The BUSY flag is cleared to 0 when the hardware-triggered A/D result register (AHR) is read.

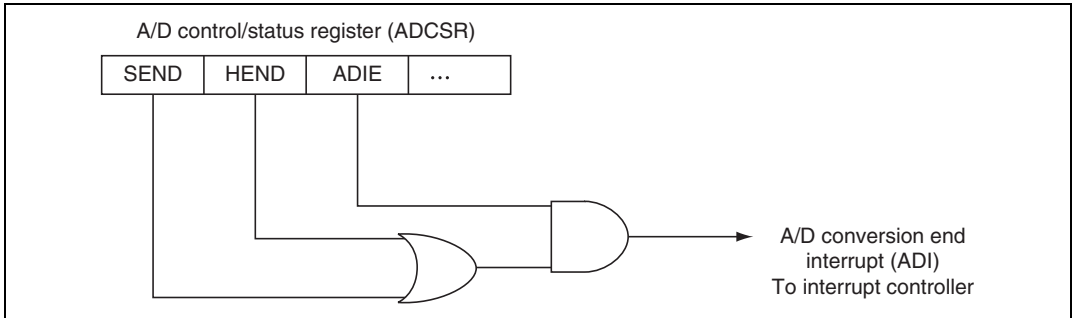
If conversion is triggered by hardware while software-triggered conversion is in progress, the software-triggered conversion is immediately canceled and the SST flag is cleared to 0, and SCNL flag in ADCSR is set to 1 (the SCNL flag is cleared when software writes 1 in the SST bit to start conversion after the hardware-triggered conversion ends). The analog input channel changes automatically from the channel that was undergoing software-triggered conversion (selected by bits SCH3 to SCH0 in ADCR) to the channel selected by bits HCH1 and HCH0 in ADCR for hardware- or external-triggered conversion. After the hardware- or external-triggered conversion ends, the channel reverts to the channel selected by the software-triggered conversion channel select bits in ADCR.

Hardware- or external-triggered conversion has priority over software-triggered conversion, so the A/D interrupt-handling routine should check the SCNL and BUSY flags when it processes the converted data.

## 26.5 Interrupt Sources

When A/D conversion ends, SEND or HEND flag in ADCSR is set to 1. The A/D conversion end interrupt can be enabled or disabled by ADIE bit in ADCSR.

Figure 26.4 shows the block diagram of A/D conversion end interrupt.



**Figure 26.4 Block Diagram of A/D Conversion End Interrupt**



## Section 27 Address Trap Controller (ATC)

### 27.1 Overview

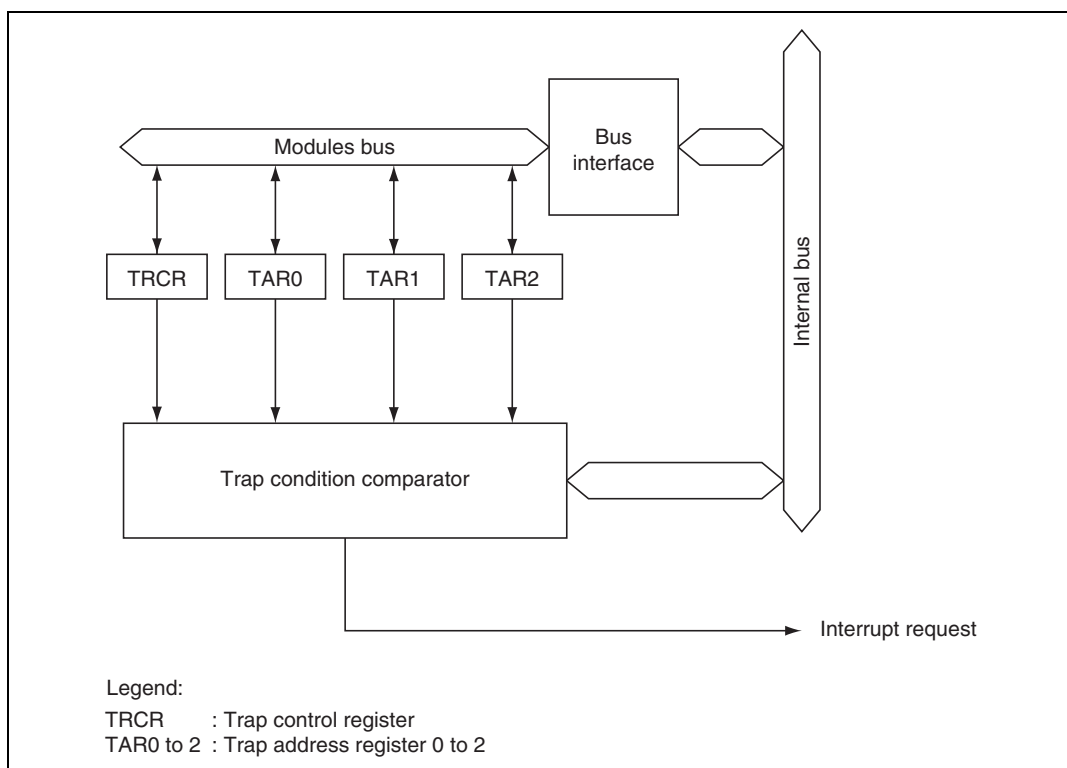
The address trap controller (ATC) is capable of generating interrupt by setting an address to trap, when the address set appears during bus cycle.

#### 27.1.1 Features

Address to trap can be set independently at three points.

#### 27.1.2 Block Diagram

Figure 27.1 shows a block diagram of the address trap controller.



**Figure 27.1 Block Diagram of ATC**

### 27.1.3 Register Configuration

**Table 27.1 Register List**

Name	Abbrev.	R/W	Initial Value	Address*
Address trap control register	ATCR	R/W	H'F8	H'FFB9
Trap address register 0	TAR0	R/W	H'F00000	H'FFB0 to H'FFB2
Trap address register 1	TAR1	R/W	H'F00000	H'FFB3 to H'FFB5
Trap address register 2	TAR2	R/W	H'F00000	H'FFB6 to H'FFB8

Note: \* Lower 16 bits of the address.

## 27.2 Register Descriptions

### 27.2.1 Address Trap Control Register (ATCR)

Bit :	7	6	5	4	3	2	1	0
	—	—	—	—	—	TRC2	TRC1	TRC0
Initial value :	1	1	1	1	1	0	0	0
R/W :	—	—	—	—	—	R/W	R/W	R/W

**Bits 7 to 3—Reserved:** When read, 1 is read at all times. Writes are disabled.

**Bit 2—Trap Control 2 (TRC2):** Sets ON/OFF operation of the address trap function 2.

#### Bit 2

TRC2	Description
0	Address trap function 2 disabled (Initial value)
1	Address trap function 2 enabled

**Bit 1—Trap Control 1 (TRC1):** Sets ON/OFF operation of the address trap function 1.

#### Bit 1

TRC1	Description
0	Address trap function 1 disabled (Initial value)
1	Address trap function 1 enabled

**Bit 0—Trap Control 0 (TRC0):** Sets ON/OFF operation of the address trap function 0.

### Bit 0

TRC0	Description
0	Address trap function 0 disabled (Initial value)
1	Address trap function 0 enabled

## 27.2.2 Trap Address Register 2 to 0 (TAR2 to TAR0)

Bit :	7	6	5	4	3	2	1	0
	A23	A22	A21	A20	A19	A18	A17	A16
Initial value :	0	0	0	0	0	0	0	0
R/W :	R/W	R/W	R/W	R/W	R/W	R/W	R/W	R/W

Bit :	7	6	5	4	3	2	1	0
	A15	A14	A13	A12	A11	A10	A9	A8
Initial value :	0	0	0	0	0	0	0	0
R/W :	R/W	R/W	R/W	R/W	R/W	R/W	R/W	R/W

Bit :	7	6	5	4	3	2	1	0
	A7	A6	A5	A4	A3	A2	A1	—
Initial value :	0	0	0	0	0	0	0	0
R/W :	R/W	R/W	R/W	R/W	R/W	R/W	R/W	—

The TAR is composed of three 8-bit readable/writable registers (TARnA, B, and C)(n = 2 to 0)

The TAR sets the address to trap. The function of the TAR2 to TAR0 is the same.

The TAR is initialized to H'00 by a reset.

TARA bits 7 to 0: Addresses 23 to 16 (A23 to A16)

TARB bits 7 to 0: Addresses 15 to 8 (A15 to A8)

TARC bits 7 to 0: Addresses 7 to 1 (A7 to A1)

If the value installed in this register and internal address buses A23 to A1 match as a result of comparison, an interruption occurs.

For the address to trap, set to the address where the first byte of an instruction exists. In the case of other addresses, it may not be considered that the condition has been satisfied.

Bit 0 of this register is fixed at 0. The address to trap becomes an even address.

The range where comparison is made is H'000000 to H'FFFFFFE.

## 27.3 Precautions in Usage

Address trap interrupt arises 2 states after prefetching the trap address. Trap interrupt may occur after the trap instruction has been executed, depending on a combination of instructions immediately preceding the setting up of the address trap.

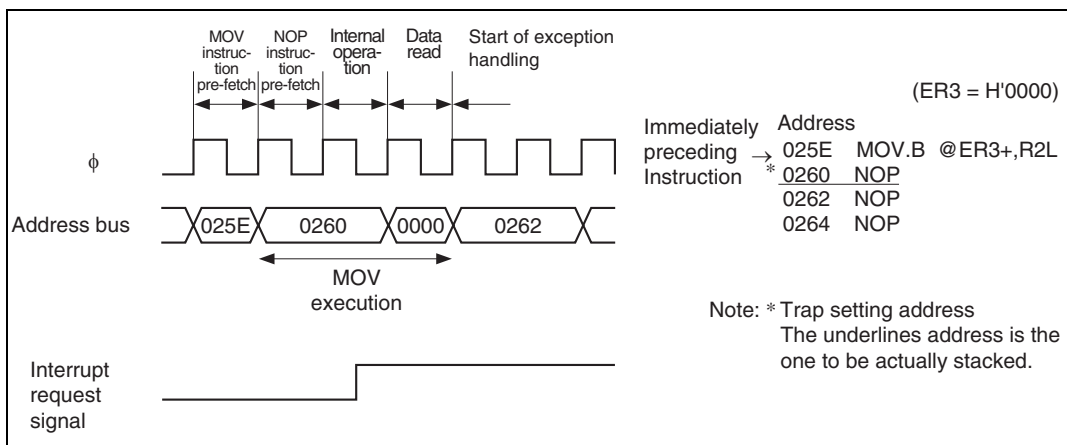
If the instruction to trap immediately follows the branch instruction or the conditional branch instruction, operation may differ, depending on whether the condition was satisfied or not, or the address to be stacked may be located at the branch. Figures 27.2 to 27.22 show specific operations.

For information as to where the next instruction prefetch occurs during the execution cycle of the instruction, see appendix A.5, Bus Status during Instruction Execution, of this manual or section 2.7, Bus State during Execution of Instruction, H8S/2600 Series, H8S/2000 Series Software Manual. (R:W NEXT is the next instruction prefetch.)

### 27.3.1 Basic Operations

After terminating the execution of the instruction being executed in the second state from the trap address prefetch, the address trap interrupt exception handling is started.

- (1) Figure 27.2 shows the operation when the instruction immediately preceding the trap address is that of 3 states or more of the execution cycle and the next instruction prefetch occurs in the state before the last 2 states. The address to be stacked is 0260.



**Figure 27.2 Basic Operations (1)**

Note: In the figure above, the NOP instruction is used as the typical example of instruction with execution cycle of 1 state. Other instructions with the execution cycle of 1 state also apply (Ex. MOV.B, Rs, Rd).



- (2) Figure 27.3 shows the operation when the instruction immediately preceding the trap address is that of 2 states or more of the execution cycle and the next instruction prefetch occurs in the second state from the last. The address to be stacked is 0268.

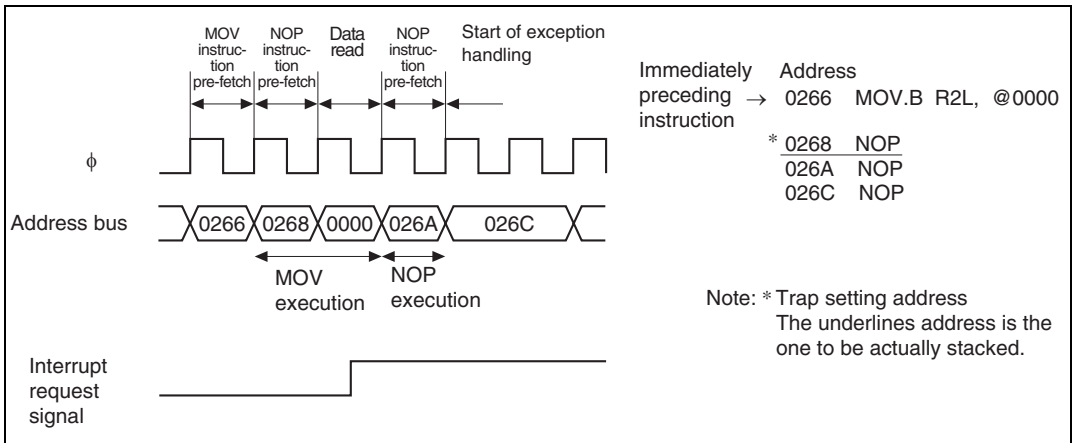


Figure 27.3 Basic Operations (2)

- (3) Figure 27.4 shows the operation when the instruction immediately preceding the trap address is that of 1 state or 2 states or more and the prefetch occurs in the last state. The address to be stacked is 025C.

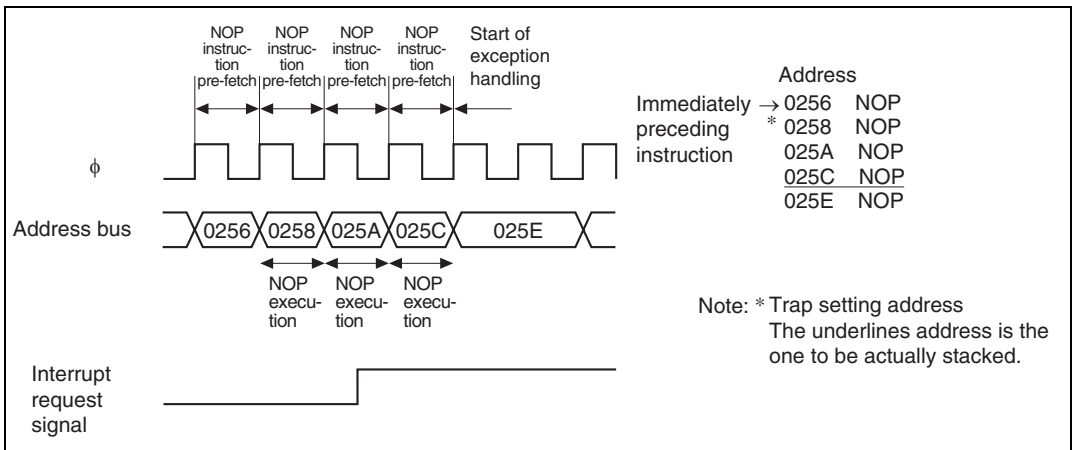
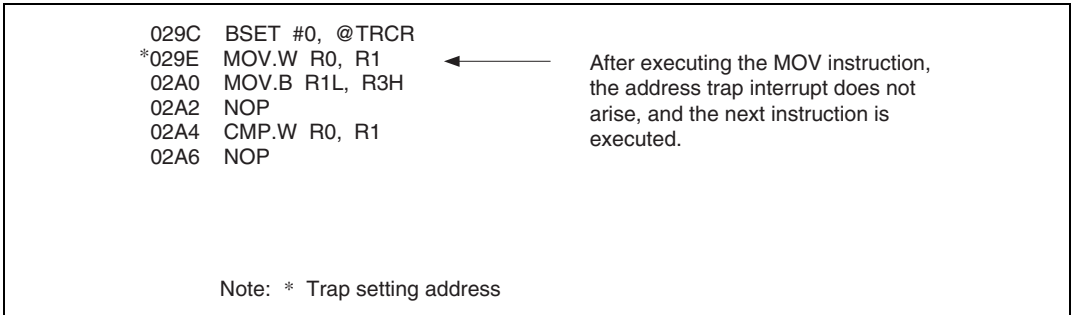


Figure 27.4 Basic Operations (3)

### 27.3.2 Enable

The address trap function becomes valid after executing one instruction following the setting of the enable bit of the address trap control register (TRCR) to 1.

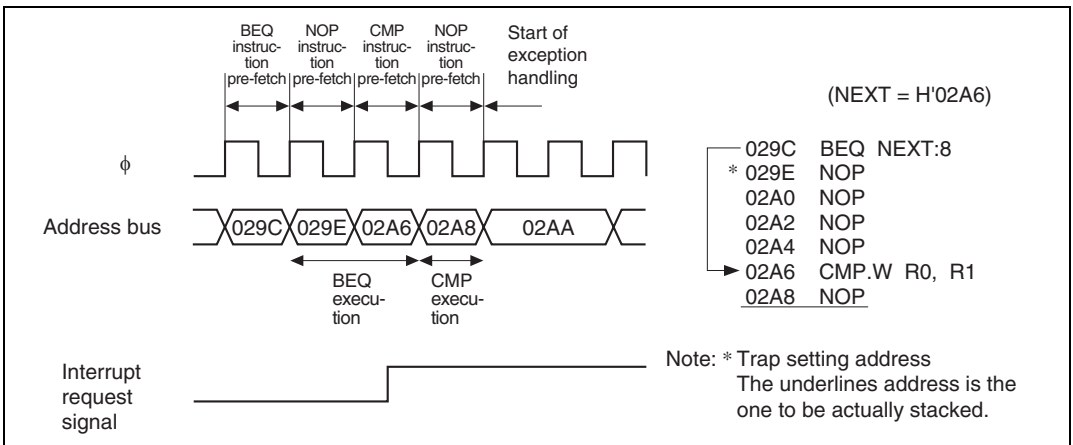


**Figure 27.5 Enable**

### 27.3.3 Bcc Instruction

(1) When the condition is satisfied by Bcc instruction (8-bit displacement)

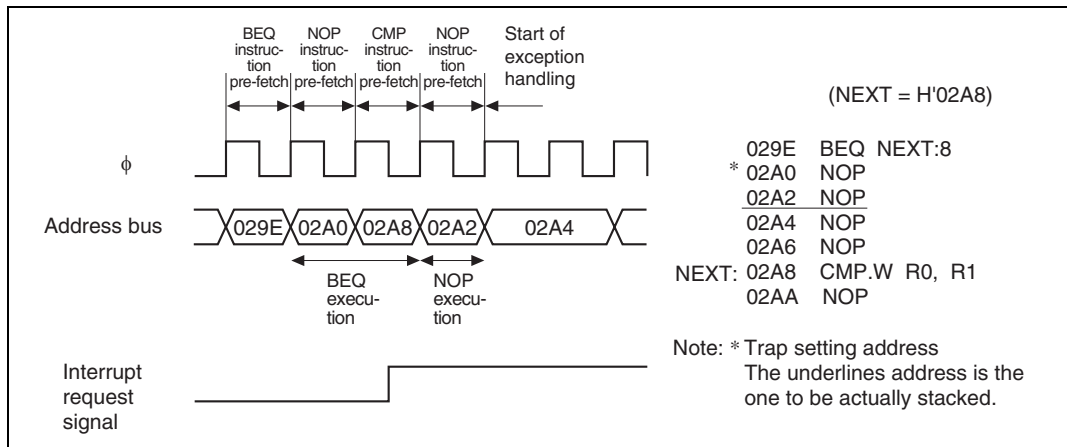
If the trap address is the next instruction to the Bcc instruction and the condition is satisfied by the Bcc instruction and then branched, transition is made to the address trap interrupt after executing the instruction at the branch. The address to be stacked is 02A8.



**Figure 27.6 When the Condition Is Satisfied by Bcc Instruction (8-Bit Displacement)**

## (2) When the condition is not satisfied by Bcc instruction (8-bit displacement)

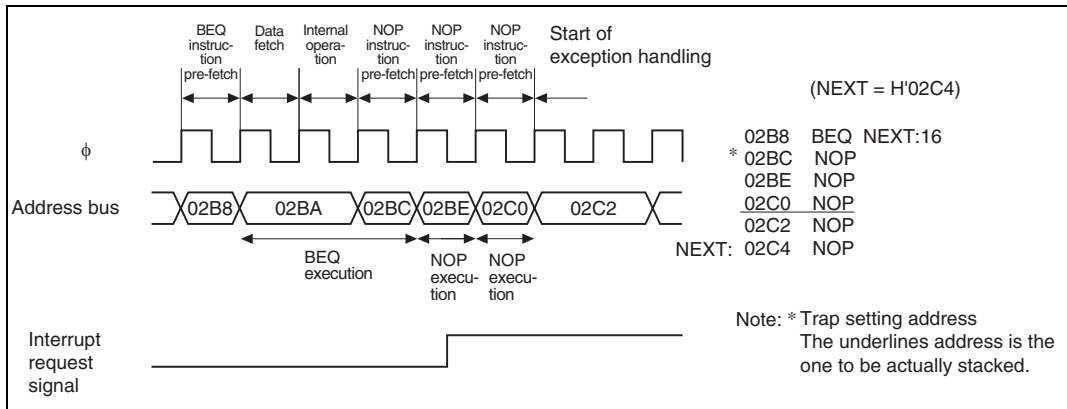
If the trap address is the next instruction to the Bcc instruction and the condition is not satisfied by the Bcc instruction and thus it fails to branch, transition is made to the address trap interrupt after executing the trap address instruction and prefetching the next instruction. The address to be stacked is 02A2.



**Figure 27.7 When the Condition Is Not Satisfied by Bcc Instruction (8-Bit Displacement)**

## (3) When condition is not satisfied by Bcc instruction (16-bit displacement)

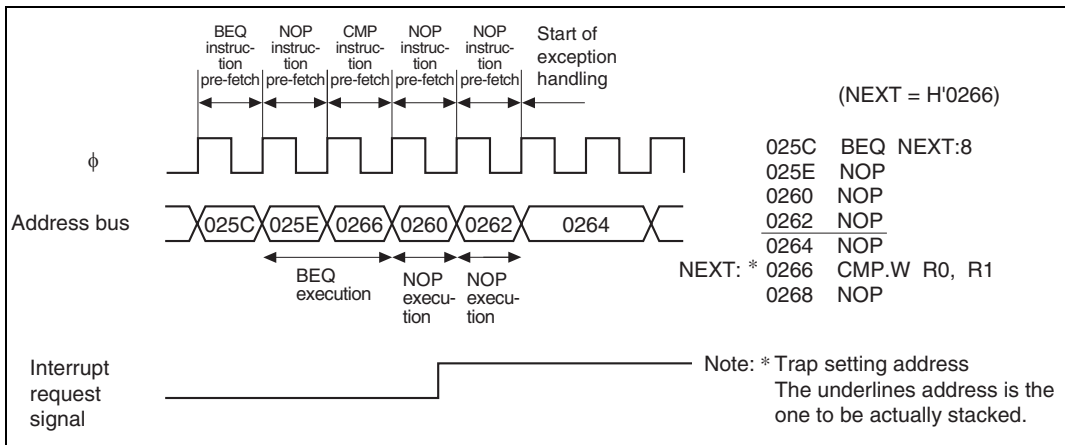
If the trap address is the next instruction to the Bcc instruction and the condition is not satisfied by the Bcc instruction and thus it fails to branch, transition is made to the address trap interrupt after executing the trap address instruction (if the trap address instruction is that of 2 states or more. If the instruction is that of 1 state, after executing two instructions). The address to be stacked is 02C0.



**Figure 27.8 When the Condition Is Not Satisfied by Bcc Instruction (16-Bit Displacement)**

## (4) When the condition is not satisfied by Bcc instruction (Trap address at branch)

When the trap address is at the branch of the Bcc instruction and the condition is not satisfied by the Bcc instruction and thus it fails to branch, transition is made into the address trap interrupt after executing the next instruction (if the next instruction is that of 2 states or more. If the next instruction is that of 1 state, after executing two instructions). The address to be stacked is 0262.

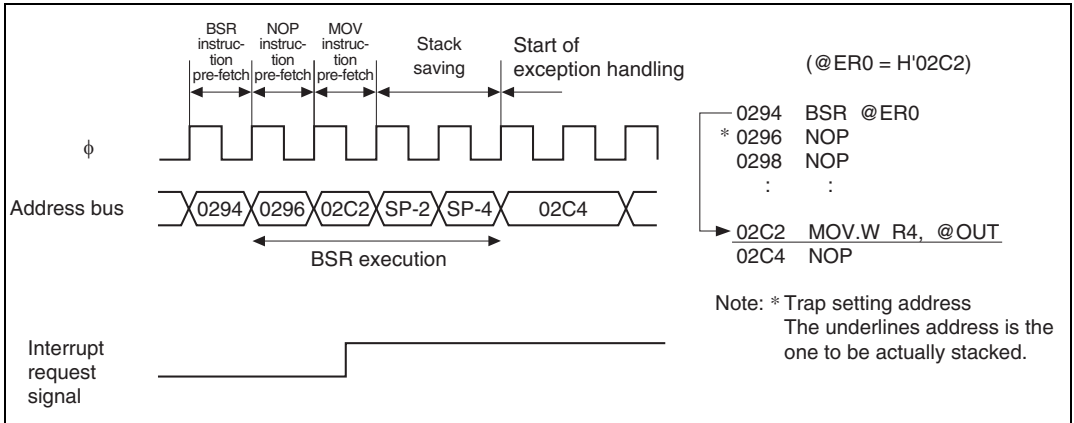


**Figure 27.9 When the Condition Is Not Satisfied by Bcc Instruction  
(Trap Address at Branch)**

### 27.3.4 BSR Instruction

#### (1) BSR Instruction (8-Bit Displacement)

When the trap address is the next instruction to the BSR instruction and the addressing mode is an 8-bit displacement, transition is made to the address trap interrupt after prefetching the instruction at the branch. The address to be stacked is 02C2.

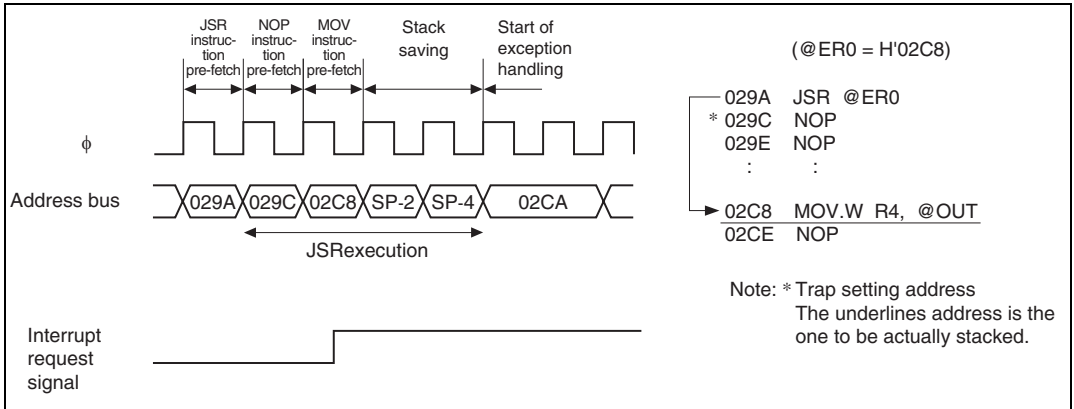


**Figure 27.10 BSR Instruction (8-Bit Displacement)**

### 27.3.5 JSR Instruction

#### (1) JSR Instruction (Register Indirect)

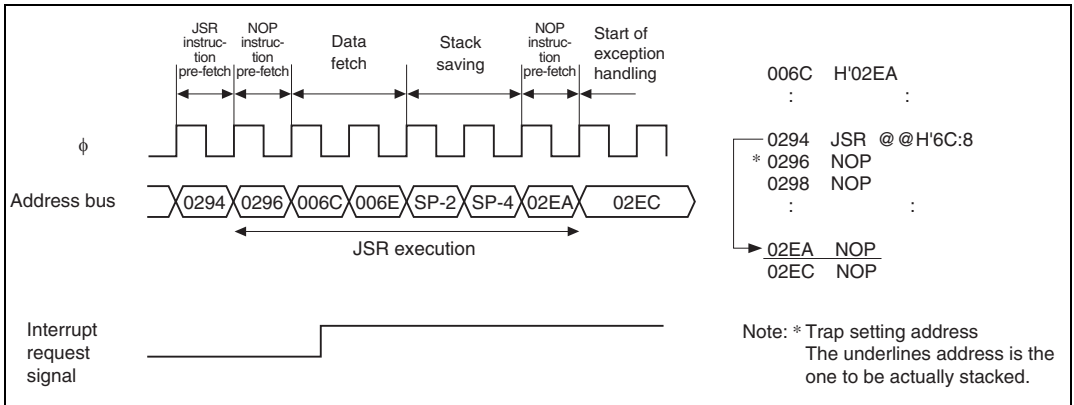
When the trap address is the next instruction to the JSR instruction and the addressing mode is a register indirect, transition is made to the address trap interrupt after prefetching the instruction at the branch. The address to be stacked is 02C8.



**Figure 27.11 JSR Instruction (Register Indirect)**

#### (2) JSR Instruction (Memory Indirect)

When the trap address is the next instruction to the JSR instruction and the addressing mode is memory indirect, transition is made to the address trap interrupt after prefetching the instruction at the branch. The address to be stacked is 02EA.



**Figure 27.12 JSR Instruction (Memory Indirect)**

### 27.3.6 JMP Instruction

#### (1) JMP Instruction (Register Indirect)

When the trap address is the next instruction to the JMP instruction and the addressing mode is a register indirect, transition is made to the address trap interrupt after prefetching the instruction at the branch. The address to be stacked is 02AA.

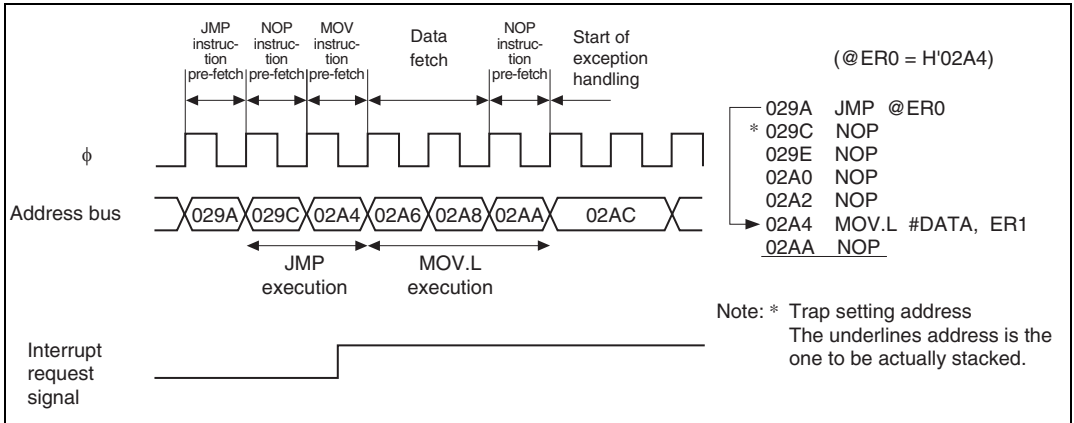


Figure 27.13 JMP Instruction (Register Indirect)

#### (2) JMP Instruction (Memory Indirect)

When the trap address is the next instruction to the JMP instruction and the addressing mode is memory indirect, transition is made to the address trap interrupt after prefetching the instruction at the branch. The address to be stacked is 02E4.

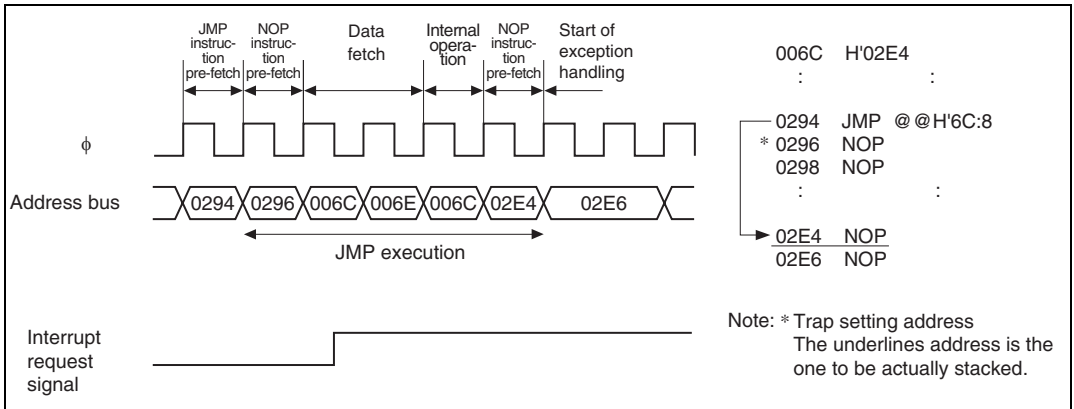


Figure 27.14 JMP Instruction (Memory Indirect)



### 27.3.7 RTS Instruction

When the trap address is the next instruction to the RTS instruction, transition is made to the address trap interrupt after reading the CCR and PC from the stack and prefetching the instruction at the return location. The address to be stacked is 0298.

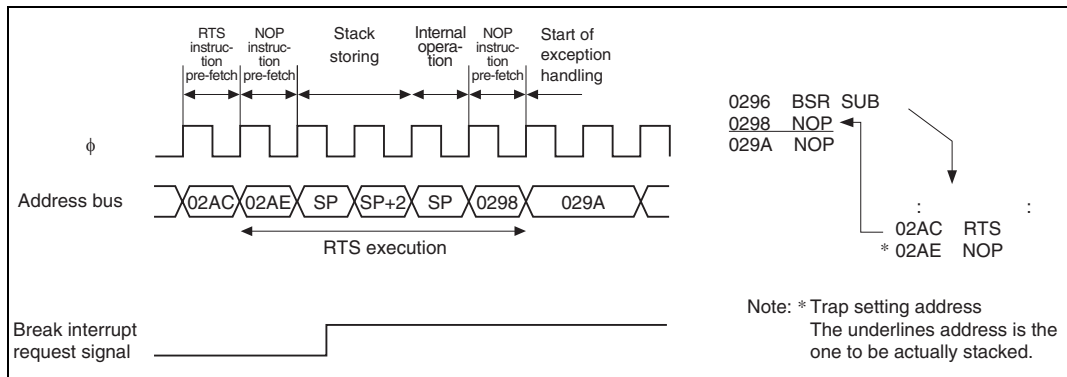


Figure 27.15 RTS Instruction

### 27.3.8 SLEEP Instruction

#### (1) SLEEP Instruction 1

When the trap address is the SLEEP instruction and the instruction execution cycle immediately preceding the SLEEP instruction is that of 2 states or more and prefetch does not occur in the last state, the SLEEP instruction is not executed and transition is made to the address trap interrupt without going into SLEEP mode. The address to be stacked is 0274.

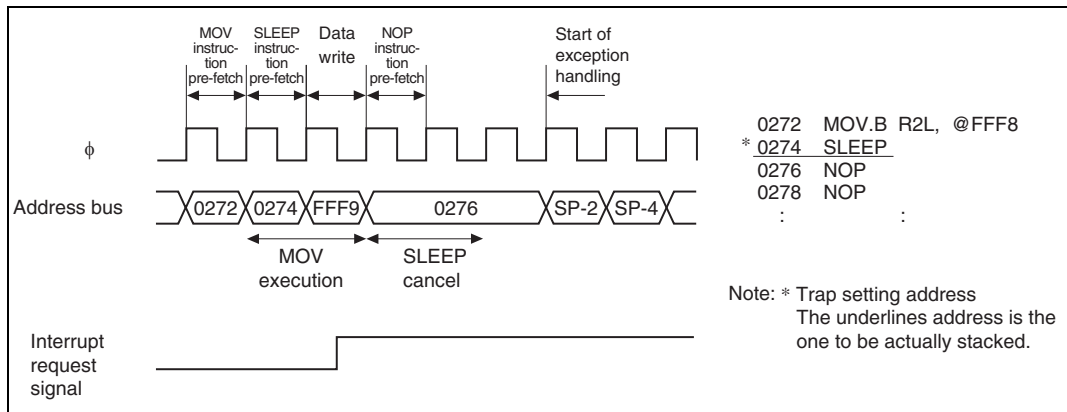


Figure 27.16 SLEEP Instruction (1)

(2) SLEEP Instruction 2

When the trap address is the SLEEP instruction and the instruction execution cycle immediately preceding the SLEEP instruction is that of 1 state 2 states or more and prefetch occurs in the last state, this puts in the SLEEP mode after execution of the SLEEP instruction, and the SLEEP mode is cancelled by the address trap interrupt and transition is made to the exception handling. The address to be stacked is 0264.

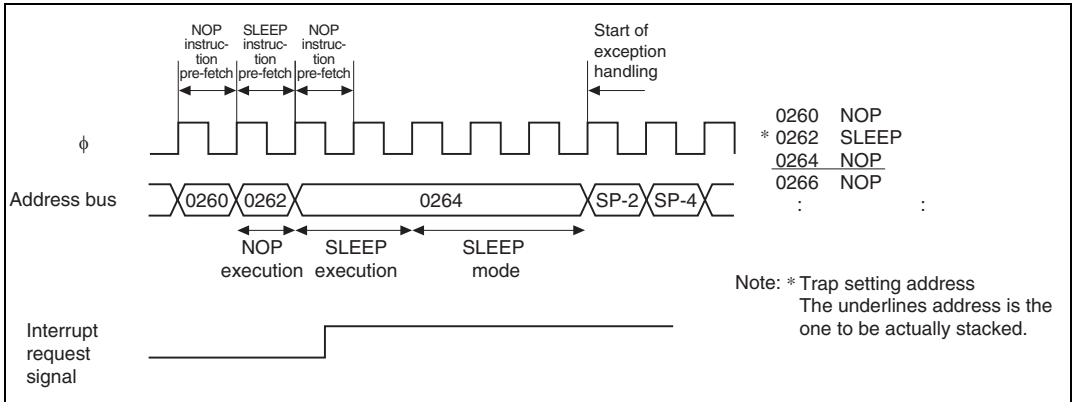


Figure 27.17 SLEEP Instruction (2)

(3) SLEEP Instruction 3

When the trap address is the next instruction to the SLEEP instruction, this puts in the SLEEP mode after execution of the SLEEP instruction, and the SLEEP mode is cancelled by the address trap interrupt and transition is made to the exception handling. The address to be stacked is 0282.

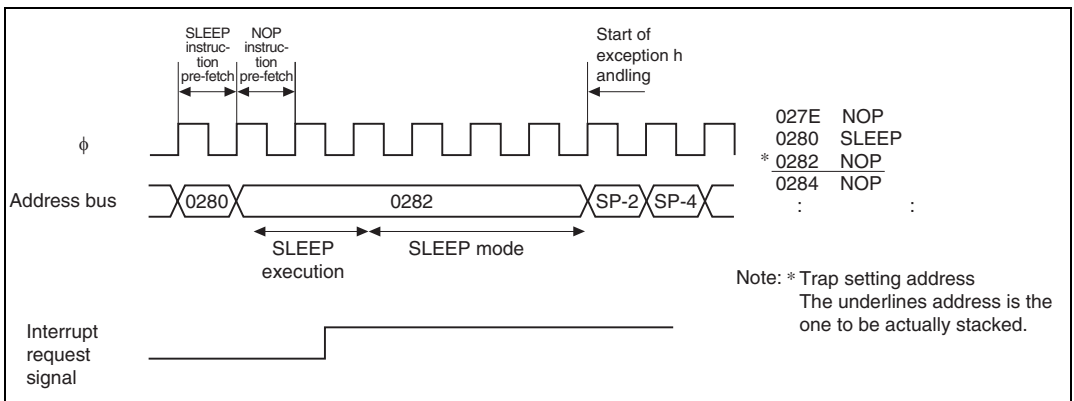
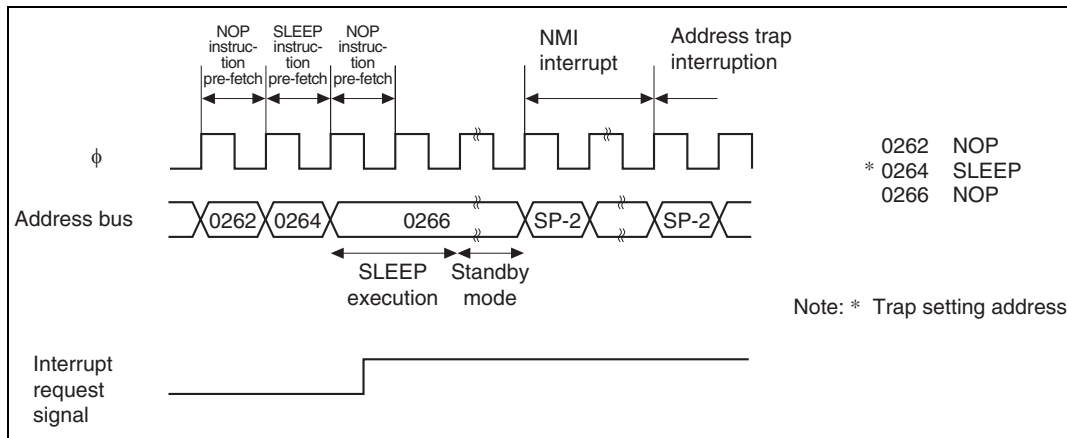


Figure 27.18 SLEEP Instruction (3)

## (4) SLEEP Instruction 4 (Standby or Watch Mode Setting)

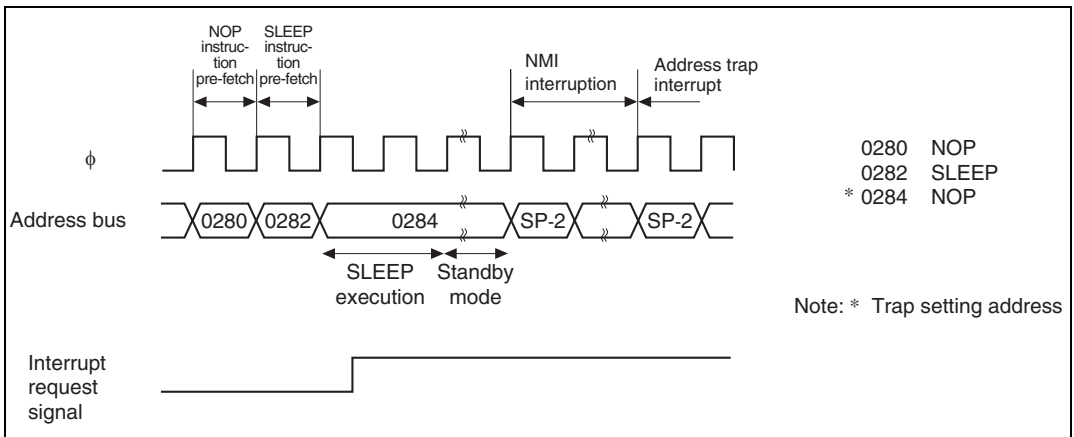
When the trap address is the SLEEP instruction and the instruction immediately preceding the SLEEP instruction is that of 1 state or 2 states or more and prefetch occurs in the last state, this puts in the standby (watch) mode after execution of the SLEEP instruction. After that, if the standby (watch) mode is cancelled by the NMI interrupt, transition is made to NMI interrupt following the CCR and PC (at the address of 0266) stack saving and vector reading. However, if the address trap interrupt arises before starting execution of the NMI interrupt processing, transition is made to the address trap exception handling. The address to be stacked is the starting address of the NMI interrupt processing.



**Figure 27.19 SLEEP Instruction (4) (Standby or Watch Mode Setting)**

## (5) SLEEP Instruction 5 (Standby or Watch Mode Setting)

When the trap address is the next instruction to the SLEEP instruction, this puts in the standby (watch) mode after execution of the SLEEP instruction. After that, if the standby (watch) mode is cancelled by the NMI interruption, transition is made to the NMI interrupt following the CCR and PC (at the address of 0266) stack saving and vector reading. However, if the address trap interrupt arises before starting execution of the NMI interrupt processing, transition is made to the address trap exception handling. The address to be stacked is the starting address of the NMI interrupt processing.



**Figure 27.20 SLEEP Instruction (5) (Standby or Watch Mode Setting)**

### 27.3.9 Competing Interrupt

#### (1) General Interrupt (Interrupt Other Than NMI)

When the ATC interrupt request is made at the timing in (1) (A) against the general interrupt request, the interruption appears to take place in the ATC at the timing earlier than usual, because higher priority is assigned to the ATC interrupt processing (Simultaneous interrupt with the general interrupt has no effect on processing). The address to be stacked is 029E. For comparison, the case where the trap address is set at 02A0 if no general interrupt request was made is shown in (2). The address to be stacked is 02A4.

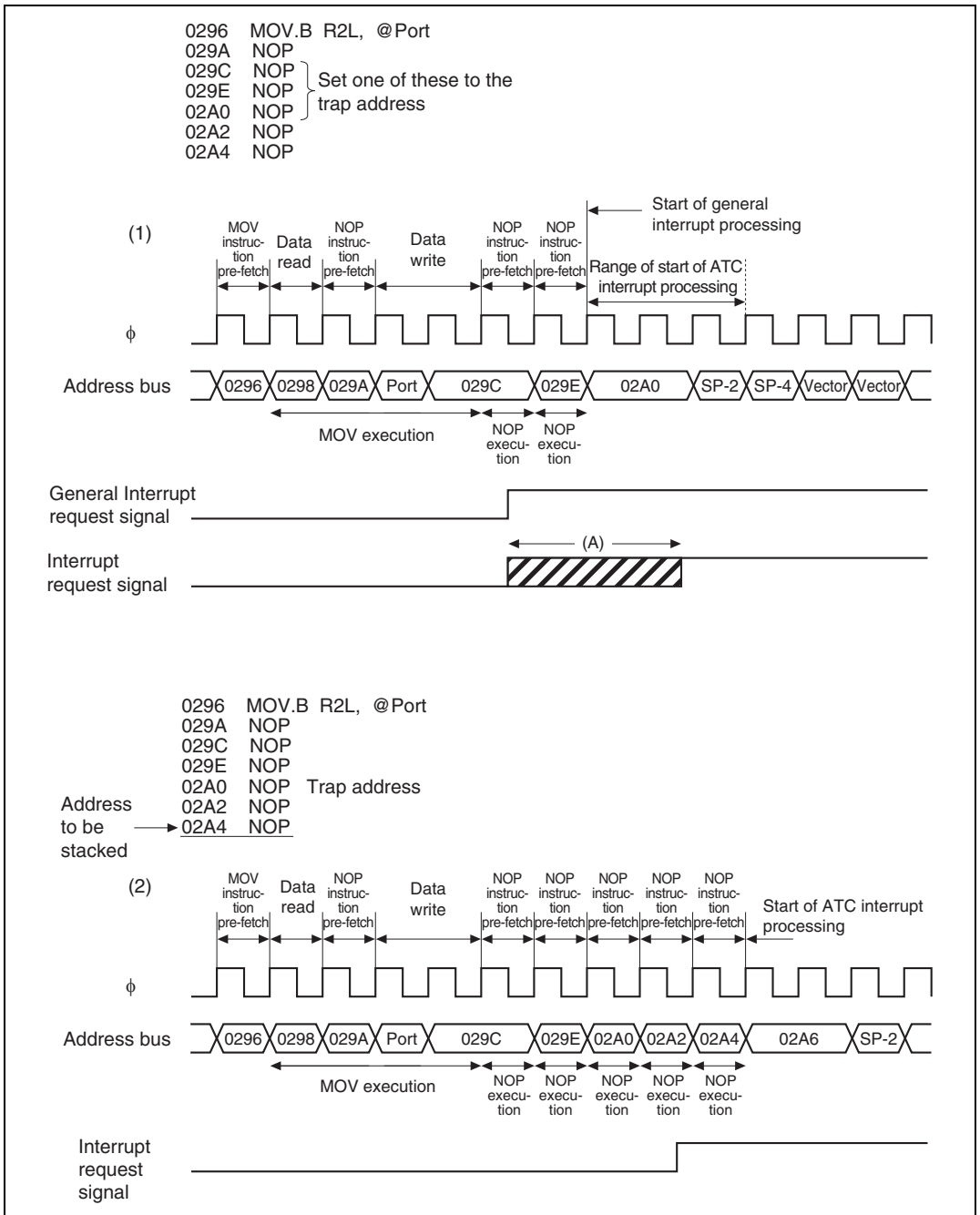


Figure 27.21 Competing Interrupt (General Interrupt)

(2) In Case of NMI

When the NMI interruption request is made at the timing in (1) (A) against the ATC interrupt request, the interrupt appears to take place in NMI at the timing earlier than usual, because higher priority is assigned to the NMI interrupt processing. The ATC interrupt processing starts after fetching the instruction at the starting address of the NMI interrupt processing. The address to be stacked is 02E0 for the NMI and 340 for the ATC.

When the ATC interrupt request is made at the timing in (2) (B) against the NMI interrupt request, the ATC interrupt processing starts after fetching the instruction at the starting address of the NMI interrupt processing. The address to be stacked is 02E6 for the NMI and 0340 for the ATC.

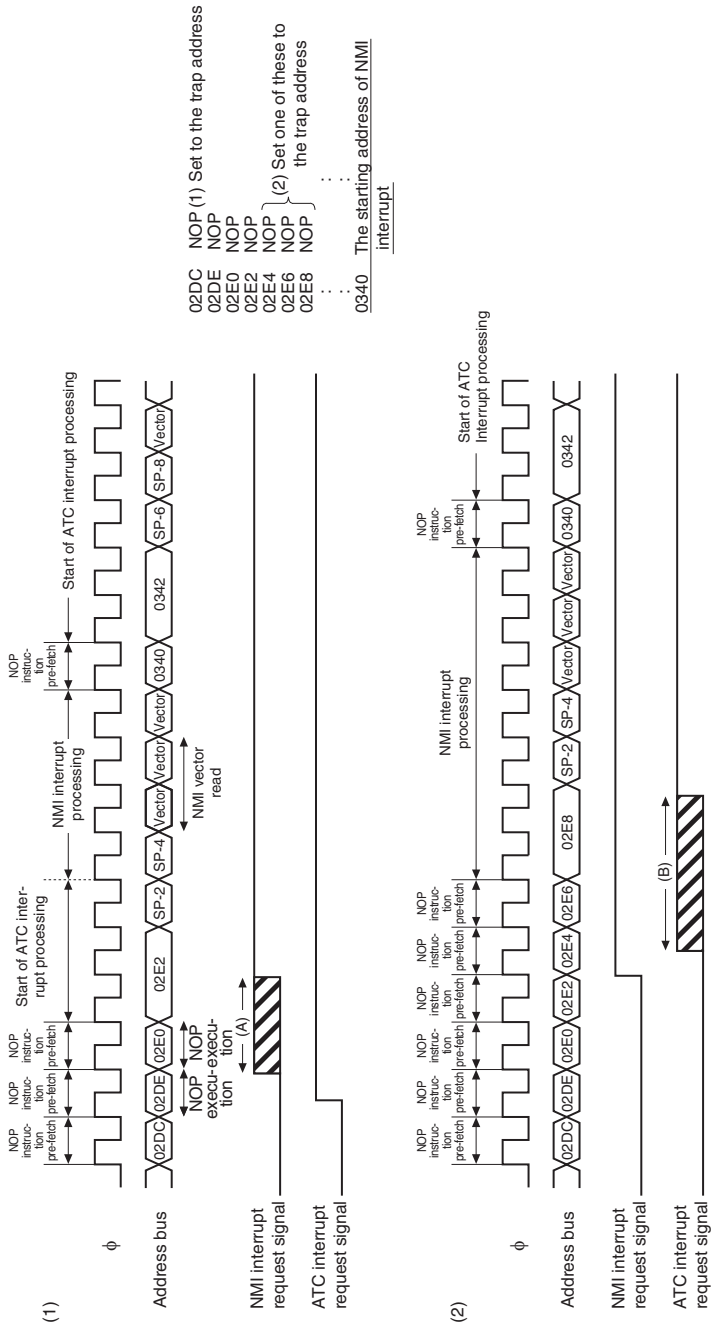


Figure 27.22 Competing Interrupt (In Case of NMI)





## Section 28 Servo Circuits

### 28.1 Overview

#### 28.1.1 Functions

Servo circuits for a video cassette recorder are included on-chip.

The functions of the servo circuits can be divided into four groups, as listed in table 28.1.

**Table 28.1 Servo Circuit Functions**

<b>Group</b>	<b>Function</b>	<b>Description</b>
(1) Input and output circuits	CTL I/O amplifier	Gain variable input amplifier Output amplifier with rewrite mode
	CFGDuty compensation input	Duty accuracy: 50 ±2% (Zero cross type comparator)
	DFG, DPG separation/overlap input	Overlap input available: Three-level input method, DFG noise mask function
	Reference signal generators	V compensation, field detection, external signal sync, V sync when in REC mode, REF30 signal output to outside
	HSW timing generator	Head-switching signals, FIFO 20 stages Compatible with DFG counter soft-reset
	Four-head high-speed switching circuit for special playback	Chroma-rotary/head-amplifier switching output
	12-bit PWM	Improved speed of carrier frequency
	Frequency division circuit	With CFG mask, no CFG for phase or CTL mask
	Sync detection circuit	Noise count, field discrimination, Hsync compensation, Hsync detection noise mask
(2) Error detectors	Drum speed error detector	Lock detector function, pause at the counter overflow, R/W error latch register, limiter function
	Drum phase error detector	Latch signal selectable, R/W error latch register
	Capstan speed error detector	Lock detector function, pause at the counter overflow, R/W error latch register, limiter function
	Capstan phase error detector	R/W error latch register
	X-value adjustment and tracking adjustment circuit	(Separate setting available)
(3) Phase and gain compensation	Digital filter computation circuit	Computations performed automatically by hardware Output gain variable: ×2 to ×64 (exponents of 2) (Partial write in Z <sup>1</sup> (high-order 8 bits) available)
(4) Other circuits	Additional V signal circuit	Valid when in special playback
	CTL circuit	Duty discrimination circuit, CTL head R/W control, compatible with wide aspect

## 28.1.2 Block Diagram

Figure 28.1 shows a block diagram of the servo circuits.

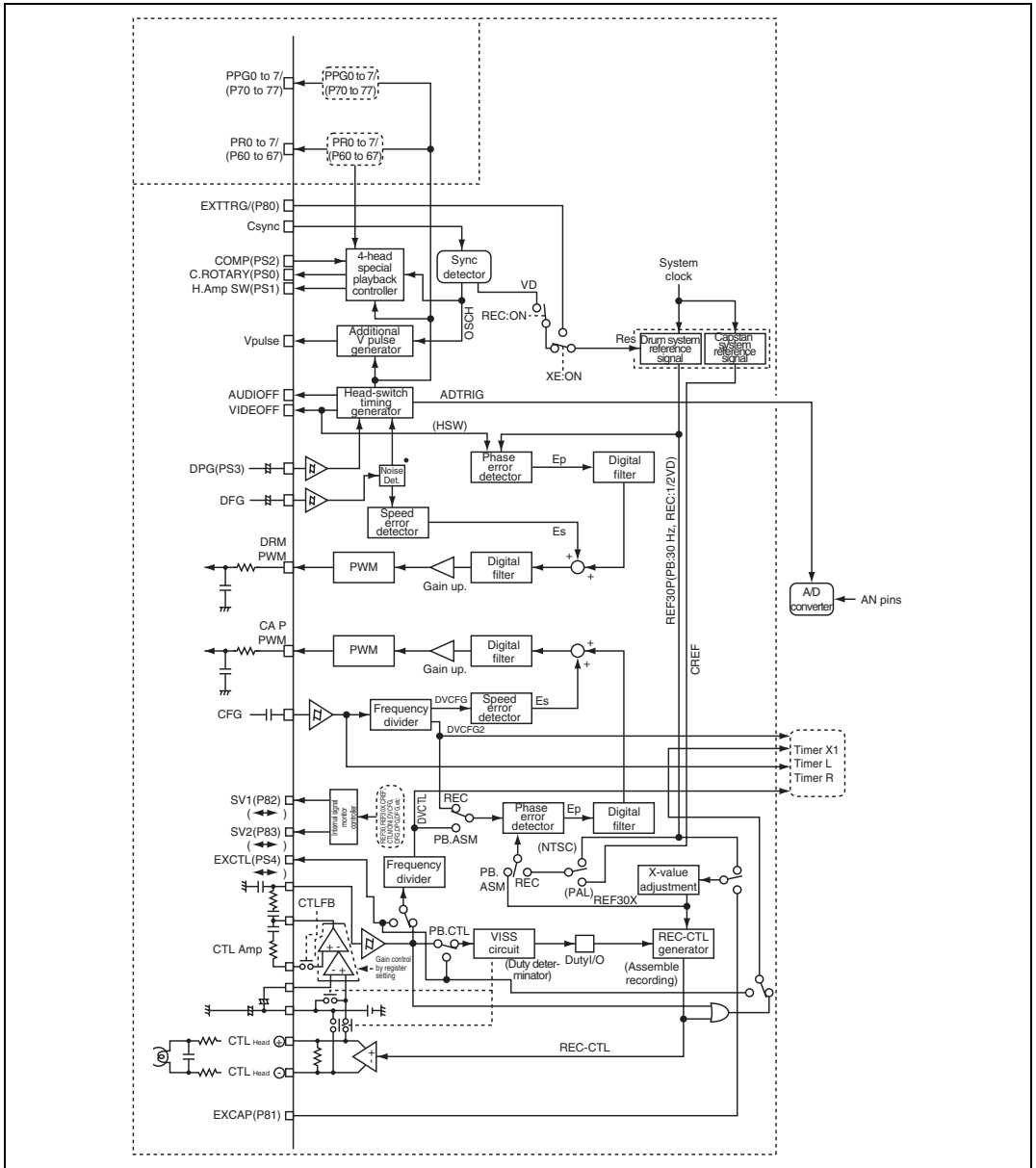


Figure 28.1 Block Diagram of Servo Circuits

## 28.2 Servo Port

### 28.2.1 Overview

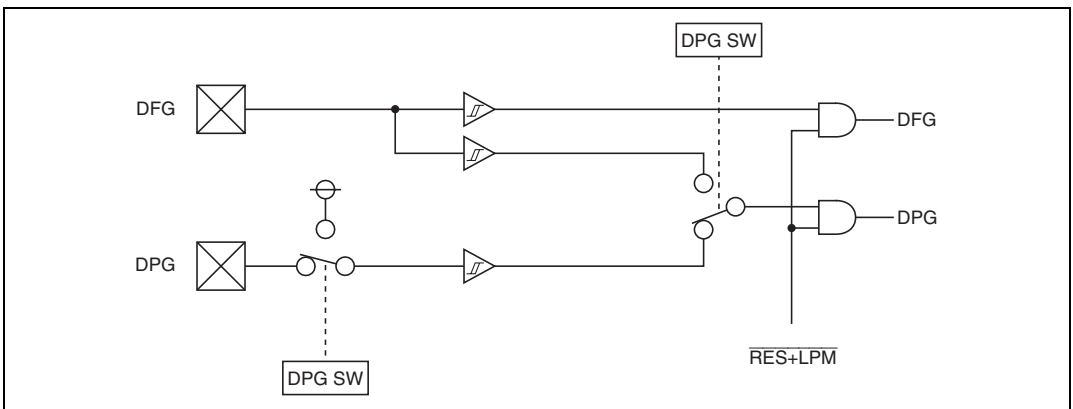
This LSI is equipped with seventeen pins dedicated to servo module and twenty-five dual-purpose pins used also for general-purpose port. It has also built-in input amplifier to amplify CTL signals, CTL output amplifier, CTL Schmitt comparator, and CFG zero cross type comparator. The CTL input amplifier allows gain adjustment by software. DFG and DPG signals, which are the signals to control the drum, allow selection between separate or overlap input.

SV1 and SV2 pins allow to output to monitor the inside signals of the servo section. The signals to be output can be selected out of eight kinds of signals. See section 28.2.5 (4), Servo Monitor Control Register (SVMCR).

### 28.2.2 Block Diagram

#### (1) DFG and DPG Input Circuits

The DFG and DPG input pins have on-chip Schmitt circuits. Figure 28.2 shows the input circuits of DFG and DPG.



**Figure 28.2 Input Circuits of DFG and DPG**

#### (2) CFG Input Circuit

The CFG input pin has built-in an amplifier and a zero cross type comparator. Figure 28.3 shows the input circuit of CFG.

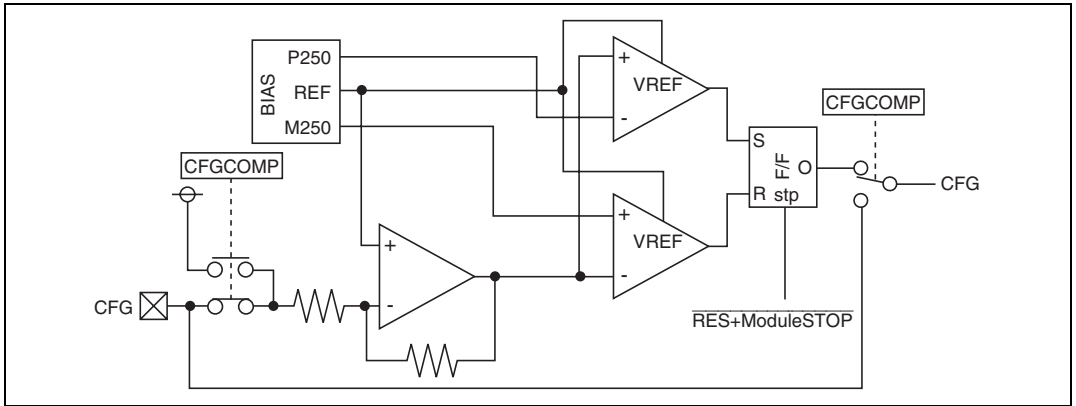


Figure 28.3 CFG Input Circuit

### (3) CTL Input Circuit

The CTL input pin has built-in an amplifier. Figure 28.4 shows the input circuit of CTL.

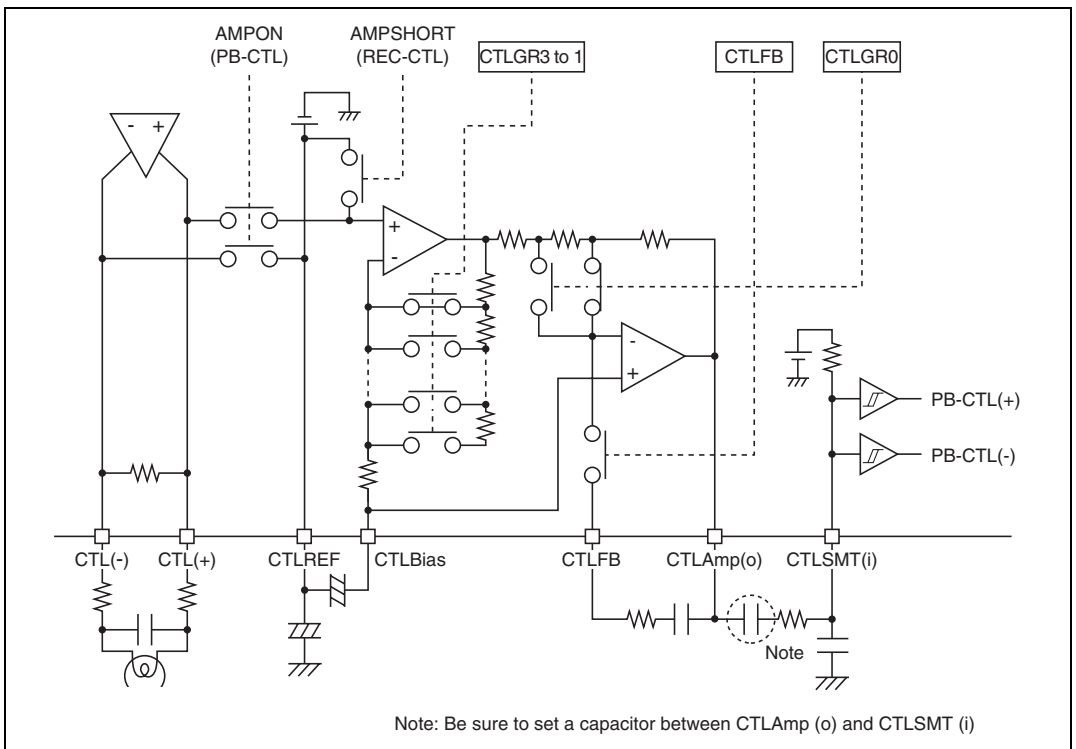


Figure 28.4 CTL Input Circuit

### 28.2.3 Pin Configuration

Table 28.2 shows the pin configuration of the servo section. P6n, P7n, P80 to P83, and PS1 to PS4 are general-purpose ports. As for P6, P7, and P8, see section 11, I/O Port.

**Table 28.2 Pin Configuration**

Name	Abbrev.	I/O	Function
Servo V <sub>cc</sub> pin	SV <sub>cc</sub>	Input	Power source pin for servo section
Servo V <sub>ss</sub> pin	SV <sub>ss</sub>	Input	Power source pin for servo section
Audio head switching pin	Audio FF	Output	Audio head switching signal output
Video head switching pin	Video FF	Output	Video head switching signal output
Capstan mix pin	CAPPWM	Output	12-bit PWM square wave output
Drum mix pin	DRMPWM	Output	12-bit PWM square wave output
Additional V pulse pin	Vpulse	Output	Additional V signal output
Color rotary signal output pin	C.Rotary/PS0	Output, I/O	Control signal output port for processing color signals/general-purpose port
Head amplifier switching pin	H.Amp. SW/PS1	Output, I/O	Pre-amplifier output selection signal output/general-purpose port
Compare signal input pin	COMP/PS2	Input, I/O	Pre-amplifier output result signal input/general-purpose port
CTL (+) I/O pin	CTL (+)	I/O	CTL signal input/output
CTL (-) I/O pin	CTL (-)	I/O	CTL signal input/output
CTL Bias input pin	CTLBias	Input	CTL primary amplifier bias supply
CTL Amp (O) output pin	CTLAMP (O)	Output	CTL amplifier output
CTL SMT (i) input pin	CTLSMT (i)	Input	CTL Schmitt amplifier input
CTL FB input pin	CTLFB	Input	CTL amplifier high-range characteristics control
CTL REF output pin	CTLREF	Output	CTL amplifier reference voltage output
Capstan FG amplifier input pin	CFG	Input	CFG signal amplifier input
Drum FG input pin	DFG	Input	DFG signal input
Drum PG input pin	DPG/PS3	Input, I/O	DPG signal input/general-purpose port
External CTL signal input pin	EXCTL/PS4	Input, I/O	External CTL signal input/general-purpose port
Complex sync signal input pin	Csync	Input	Complex sync signal input

Name	Abbrev.	I/O	Function
External reference signal input pin	P80/EXTTRG	I/O, input	General-purpose port/external reference signal input
External capstan signal input pin	P81/EXCAP	I/O, input	General-purpose port/external capstan signal input
Servo monitor signal output pin 1	P82/SV1	I/O, output	General-purpose port/servo monitor signal output
Servo monitor signal output pin 2	P83/SV2	I/O, output	General-purpose port/servo monitor signal output
PPG output pin	P7n/PPGn	I/O, output	General-purpose port/PPG output
RTP output pin	P6n/RPn	I/O, output	General-purpose port/RTP output

### 28.2.4 Register Configuration

Table 28.3 shows the register configuration of the servo port section.

**Table 28.3 Register Configuration**

Name	Abbrev.	R/W	Size	Initial Value	Address
Servo port mode register	SPMR	R/W	Byte	H'40	H'FD0A0
Servo control register	SPCR	W	Byte	H'E0	H'FD0A1
Servo data register	SPDR	R/W	Byte	H'E0	H'FD0A2
Servo monitor control register	SVMCR	R/W	Byte	H'C0	H'FD0A3
CTL gain control register	CTLGR	R/W	Byte	H'C0	H'FD0A4

### 28.2.5 Register Descriptions

#### (1) Servo Port Mode Register (SPMR)

Bit :	7	6	5	4	3	2	1	0
	CTLSTOP	—	CFGCOMP	EXCTLON	DPGSW	COMP	H.Amp.SW	C.Rot
Initial value :	0	1	0	0	0	0	0	0
R/W :	R/W	—	R/W	R/W	R/W	R/W	R/W	R/W

A register to switch the servo port/general-purpose port, and the CFG input system. SPMR is an 8-bit read/write register. Bit 6 is reserved; writing in it is invalid. If read is attempted, an undetermined value is read out. It is initialized to H'40 by a reset or stand-by.

**Bit 7—CTLSTOP Bit (CTLSTOP):** Controls whether the CTL circuits are operated or stopped.

#### Bit 7

CTLSTOP	Description	
0	CTL circuits operate	(Initial value)
1	CTL circuits stop operation	

**Bit 6—Reserved:** This bit is reserved. It cannot be written or read. If read is attempted, an undetermined value is read out.

**Bit 5—CFG Input System Switching Bit (CFGCOMP):** Selects whether the CFG input signal system is set to the zero cross type comparator system or digital signal input system.

#### Bit 5

CFGCOMP	Description	
0	CFG signal input system is set to the zero cross type comparator system	(Initial value)
1	CFG signal input system is set to the digital signal input system	

**Bit 4—EXCTL Pin Switching Bit (EXCTLON):** Selects whether the EXCTL/PS4 pin is used as the EXCTL input pin or PS4 (general-purpose I/O pin).

#### Bit 4

EXCTLON	Description	
0	EXCTL/PS4 pin functions as EXCTL input pin	(Initial value)
1	EXCTL/PS4 pin functions as PS4 I/O	



**Bit 3—DPG Pin Switching Bit (DPGSW):** Selects the drum control system input signals (DFG, DPG) as separate or overlapped inputs.

**Bit 3**

<b>DPGSW</b>	<b>Description</b>
0	Drum control system inputs are separate inputs (DPG/PS3 pin functions as DPG input pin) (Initial value)
1	Drum control system inputs are overlapped inputs (DPG/PS3 pin functions as PS3 I/O pin)

**Bit 2—COMP Pin Switching Pin (COMP):** Selects whether the COMP/PS2 pin is used as the COMP input pin or PS2 (general-purpose I/O pin).

**Bit 2**

<b>COMP</b>	<b>Description</b>
0	COMP/PS2 pin functions as COMP input pin (Initial value)
1	COMP/PS2 pin functions as PS2 I/O pin

**Bit 1—H.Amp SW Pin Switching Bit (H.Amp.SW):** Selects whether the H.Amp SW/PS1 pin is used as the H.Amp SW output pin or PS1 (general-purpose I/O pin).

**Bit 1**

<b>H.Amp.SW</b>	<b>Description</b>
0	H.Amp SW/PS1 pin functions as H.Amp SW output pin (Initial value)
1	H.Amp SW/PS1 pin functions as PS1 I/O pin

**Bit 0—C.Rotary Pin Switching Bit (C.Rot):** Selects whether the C.Rotary/PS0 pin is used as the C.Rotary output pin or PS0 (general-purpose I/O pin).

**Bit 0**

<b>C.Rot</b>	<b>Description</b>
0	C.Rotary/PS0 pin functions as C.Rotary output pin (Initial value)
1	C.Rotary/PS0 pin functions as PS0 I/O pin

**(2) Servo Control Register (SPCR)**

Bit :	7	6	5	4	3	2	1	0
	—	—	—	SPCR4	SPCR3	SPCR2	SPCR1	SPCR0
Initial value :	1	1	1	0	0	0	0	0
R/W :	—	—	—	W	W	W	W	W

Controls input and output of each pin (PS4 to PS0) for each bit when the servo port/general-purpose port dual-purpose pin is used as the general-purpose port. If SPCR is set to 1, the corresponding PS4 to PS0 pins function as output pins; if cleared to 0, they function as input pins. Settings of SPCR and SPDR are valid if the corresponding pins are set to general-purpose I/O by SPMR.

SPCR is an 8-bit write-only register. If read is attempted, an undetermined value is read out.

Bits 7 to 5 are reserved bits. Writes are disabled.

SPCR is initialized to H'E0 by a reset or stand-by.

**Bit n**

SPCRn	Description	
0	PSn pin functions as input	(Initial value)
1	PSn pin functions as output	

**(3) Servo Data Register (SPDR)**

Bit :	7	6	5	4	3	2	1	0
	—	—	—	SPDR4	SPDR3	SPDR2	SPDR1	SPDR0
Initial value :	1	1	1	0	0	0	0	0
R/W :	—	—	—	R/W	R/W	R/W	R/W	R/W

Stores the data of each pin (PS4 to PS0) when the servo port/general-purpose dual-purpose pin is used as general-purpose port. If the port is accessed for read when SPCR is 1 (output), the SPDRn value is read directly. Accordingly, this register is not affected by the state of the pin. If the port is accessed for read when SPCR is 0 (input), the state of the pin is read out.

SPDR is an 8-bit read/write register. Bits 7 to 5 are reserved. No write in it is valid. If read is attempted, an undetermined value is read out.

SPCR is initialized to H'E0 by reset or stand-by.

**(4) Servo Monitor Control Register (SVMCR)**

Bit :	7	6	5	4	3	2	1	0
	—	—	SVMCR5	SVMCR4	SVMCR3	SVMCR2	SVMCR1	SVMCR0
Initial value :	1	1	0	0	0	0	0	0
R/W :	—	—	R/W	R/W	R/W	R/W	R/W	R/W

Selects the monitor signal output to the SV1 and SV2 pins when the P82/SV1 pin is used as the SV1 monitor output pin or when the P83/SV2 pin is used as the SV2 monitor output pin.

SVMCR is an 8-bit read/write register. Bits 7 and 6 are reserved. Writes are disabled. If read is attempted, an undetermined value is read out. It is initialized to H'C0 by a reset or stand-by.

Bit 5	Bit 4	Bit 3	Description
SVMCR5	SVMCR4	SVMCR3	
0	0	0	Outputs REF30 signal to SV2 output pin (Initial value)
		1	Outputs CAPREF30 signal to SV2 output pin
	1	0	Outputs CREF signal to SV2 output pin
		1	Outputs CTLMONI signal to SV2 output pin
1	0	0	Outputs DVCFG signal to SV2 output pin
		1	Outputs CFG signal to SV2 output pin
	1	0	Outputs DFG signal to SV2 output pin
		1	Outputs DPG signal to SV2 output pin

Bit 2	Bit 1	Bit 0	Description
SVMCR2	SVMCR1	SVMCR0	
0	0	0	Outputs REF30 signal to SV1 output pin (Initial value)
		1	Outputs CAPREF30 signal to SV1 output pin
	1	0	Outputs CREF signal to SV1 output pin
		1	Outputs CTLMONI signal to SV1 output pin
1	0	0	Outputs DVCFG signal to SV1 output pin
		1	Outputs CFG signal to SV1 output pin
	1	0	Outputs DFG signal to SV1 output pin
		1	Outputs DPG signal to SV1 output pin

**(5) CTL Gain Control Register (CTLGR)**

Bit :	7	6	5	4	3	2	1	0
	—	—	CTLE/ $\bar{A}$	CTLFB	CTLGR3	CTLGR2	CTLGR1	CTLGR0
Initial value :	1	1	0	0	0	0	0	0
R/W :	—	—	R/W	R/W	R/W	R/W	R/W	R/W

Sets the CTLFB switch in the CTL amplifier circuit to on/off and CTL amplifier gain.

CTLGR is an 8-bit read/write register. Bits 7 and 6 are reserved. No write in it is valid. If read is attempted, an undetermined value is read out. It is initialized to H'C0 by a reset or stand-by.

**Bits 7 and 6—Reserved:** Reserved bits; writes are disabled. If read was attempted, an undetermined value is read out.

**Bit 5—CTL Selection Bit (CTLE/ $\bar{A}$ ):** Controls whether the amplifier output or EXCTL is used as the CTLP signal supplied to the CTL circuit.

**Bit 5**

CTLE/ $\bar{A}$	Description
0	AMP output (Initial value)
1	EXCTL

**Bit 4—SW Bit of the Feedback Section of CTL Amplifier (CTLFB):** Turning on/off the SW of the feedback section allows adjustment of gain.

See figure 28.4, CTL Input Circuit.

**Bit 4**

CTLFB	Description
0	Turns off CTLFB SW (Initial value)
1	Turns on CTLFB SW

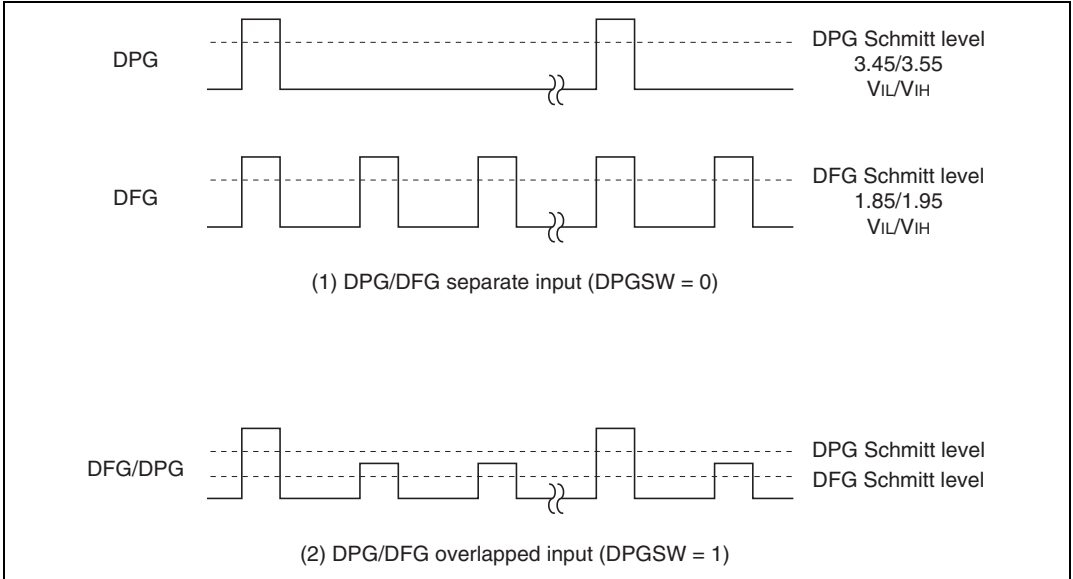
**Bits 3 to 0—CTL Amplifier Gain Setting Bits (CTLGR3 to 0):** Set the output gain of the CTL amplifier.

Bit 3	Bit 2	Bit 1	Bit 0	CTL Output Gain
CTLGR3	CTLGR2	CTLGR1	CTLGR0	
0	0	0	0	34.0 dB (Initial value)
			1	36.5 dB
		1	0	39.0 dB
			1	41.5 dB
	1	0	0	44.0 dB
			1	46.5 dB
		1	0	49.0 dB
			1	51.5 dB
1	0	0	0	54.0 dB
			1	56.5 dB
		1	0	59.0 dB
			1	61.5 dB
	1	0	0	64.0 dB*
			1	66.5 dB*
		1	0	69.0 dB*
			1	71.5 dB*

Note: \* With a setting of 64.0 dB or more, the CTLAMP is in a very sensitive status. When configuring the set board, be concerned about countermeasure against noise around the control head signal input port. Also, thoroughly set the filter between the CTLAMP and CTLSMT.

### 28.2.6 DFG/DPG Input Signals

DFG and DPG signals allow either separate or overlapped input. If the latter was selected (DPGSW = 1), take care in the input levels of DFG and DPG. Figure 28.5 shows DFG/DPG input signals.



**Figure 28.5 DFG/DPG Input Signals**

## 28.3 Reference Signal Generators

### 28.3.1 Overview

The reference signal generators consist of REF30 signal generator and CREF signal generator, and they create the reference signals (REF30 and CREF signals) used in phase comparison, etc. The REF30 signal is used to control the phase of the drum and capstan. The CREF signal is used if the reference signal to control the phase of the capstan cannot be shared with the REF30 signal in REC mode. Each signal generator consists of a 16-bit counter which has the servo clock  $\phi s/2$  (or  $\phi s/4$ ) as its clock source, a reference period register and a comparator.

The value set in the reference period register should be  $1/2$  of the desired reference signal period.

### 28.3.2 Block Diagram

Figure 28.6 shows the block diagram of the REF30 signal generator. Figure 28.7 shows that of the CREF signal generator.

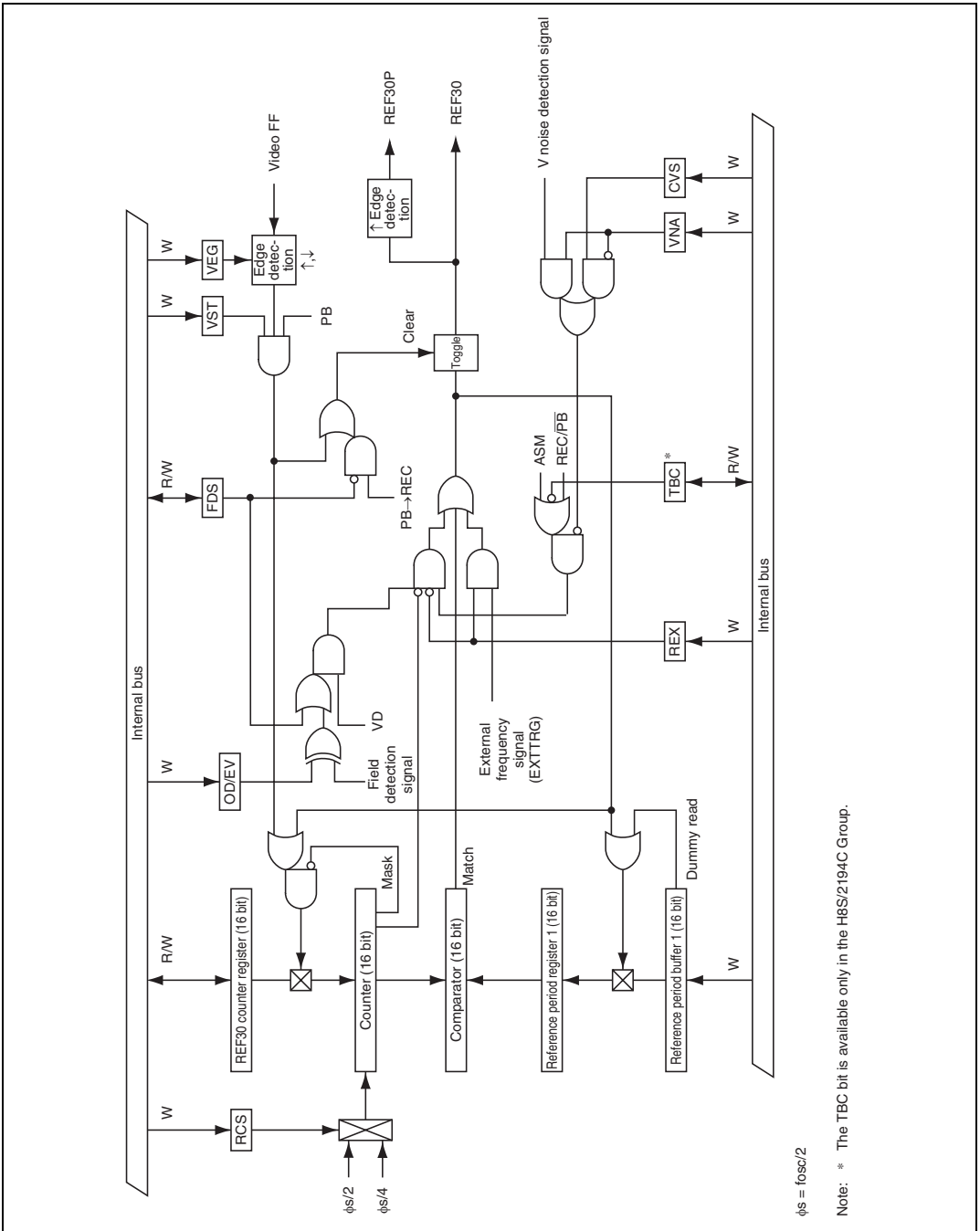
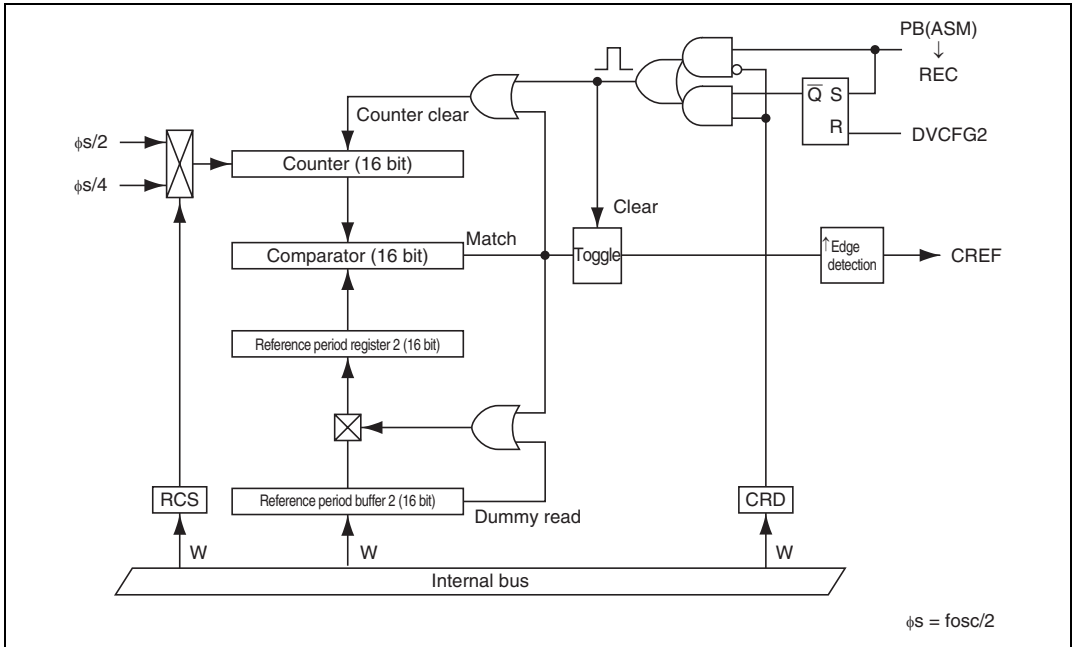


Figure 28.6 REF30 Signal Generator





**Figure 28.7 Block Diagram of CREF Signal Generator**

### 28.3.3 Register Configuration

Table 28.4 shows the register configuration of the reference signal generators.

**Table 28.4 Register Configuration**

Name	Abbrev.	R/W	Size	Initial Value	Address
Reference period mode register	RFM	W	Byte	H'00	H'FD096
Reference period register 1	RFD	W	Word	H'FFFF	H'FD090
Reference period register 2	CRF	W	Word	H'FFFF	H'FD092
REF30 counter register	RFC	R/W	Word	H'0000	H'FD094
Reference period mode register 2	RFM2	R/W	Byte	H'FE	H'FD097

### 28.3.4 Register Descriptions

#### (1) Reference Period Mode Register (RFM)

Bit :	7	6	5	4	3	2	1	0
	RCS	VNA	CVS	REX	CRD	OD/EV	VST	VEG
Initial value :	0	0	0	0	0	0	0	0
R/W :	W	W	W	W	W	W	W	W

RFM is an 8-bit write-only register which determines the operational state of the reference signal generators. If a read is attempted, an undetermined value is read out.

It is initialized to H'00 by a reset, stand-by or module stop.

RFM is accessible by byte access only. If accessed by a word, its operation is not assured.

**Bit 7—Clock Source Selection Bit (RCS):** Selects the clock source supplied to the counter. ( $\phi_s = f_{osc}/2$ )

#### Bit 7

RCS	Description
0	$\phi_s/2$ (Initial value)
1	$\phi_s/4$

**Bit 6—Mode Selection Bit (VNA):** Selects whether the transition to free-run operation when the REF30 signals are being generated in sync with the VD signals in REC mode is controlled automatically by the V noise detection signal, which has been detected by the sync signal detection circuit, or is controlled manually by software.

#### Bit 6

VNA	Description
0	Manual mode (Initial value)
1	Auto mode

**Bit 5—Manual Selection Bit (CVS):** Selects whether the REF30 signals are generated in sync with VD or operated free-run in manual mode (VNA = 0). (No selection is reflected in PB mode, except in TBC mode.)

**Bit 5**

CVS	Description
0	Sync with VD (Initial value)
1	Free-run operation

**Bit 4—External Signals Sync Selection Bit (REX):** Selects whether the REF30 signals are generated in sync with VD or in free-run or in sync with the external signals. (Valid in both PB and REC modes.)

**Bit 4**

REX	Description
0	VD signals or free-run (Initial value)
1	Sync with external signals

**Bit 3—DVCFG2 Sync Selection Bit (CRD):** Selects whether the reset timing in the CREF signals generation is immediately after switching from PB (ASM) mode to REC mode or is in sync with the DVCFG2 signals immediately after the switching.

**Bit 3**

CRD	Description
0	On switching modes (Initial value)
1	In sync with DVCFG2 signals

**Bit 2—ODD/EVEN Edge Switching Selection Bit (OD/EV):** Selects whether REF30P signals are generated by ODD of the field signals or EVEN when in REC mode.

**Bit 2**

OD/EV	Description
0	Generated at the rising edge (EVEN) of the field signals (Initial value)
1	Generated at the falling edge (ODD) of the field signals

**Bit 1—Video FF Counter Set (VST):** Selects whether the REF30 counter register value is set on or off by the Video FF signal when the drum phase is in FIX on in PB mode.

**Bit 1**

VST	Description
0	Counter set off by Video FF signal (Initial value)
1	Counter set on by Video FF signal

**Bit 0—Video FF Edge Selection Bit (VEG):** Selects the edge at which the REF30 counter is set (VST = 1) by the Video FF signal.

**Bit 0**

VEG	Description
0	Set at the rising edge of Video FF signal (Initial value)
1	Set at the falling edge of Video FF signal

**(2) Reference Period Register 1 (RFD)**

Bit :	15	14	13	12	11	10	9	8	7	6	5	4	3	2	1	0
	REF15	REF14	REF13	REF12	REF11	REF10	REF9	REF8	REF7	REF6	REF5	REF4	REF3	REF2	REF1	REF0
Initial value :	1	1	1	1	1	1	1	1	1	1	1	1	1	1	1	1
R/W :	W	W	W	W	W	W	W	W	W	W	W	W	W	W	W	W

The reference period register 1 (RFD) is a buffer register which generates the reference signals for playback (REF30), VD compensation for recording and the reference signals for free-running. It is a 16-bit write-only register accessible by a word only. If a read is attempted, an undetermined value is read out.

The value set in RFD should be 1/2 of the desired reference signal period. Care is required when VD is unstable, such as when the field is weak (Synchronization with VD cannot be acquired if a value less than 1/2 is set when in REC). When data is written in RFD, it is stored in the buffer once, and then fetched into RFD by a match signal of the comparator. (The data which generates the reference signal is updated from time to time by the match signal.) An enforced write, such as initial setting, etc., should be done by a dummy read of RFD.

If a byte-write in RFD is attempted, no operation is assured. RFD is initialized to H'FFFF by a reset, stand-by, or module stop.

Use bit 7 (ASM) and bit 6 (REC/PB) in the CTL mode register (CTLM) in the CTL circuit to switch between record and playback modes. Use bit 4 (CR/RF bit) in the capstan phase error detection control register (CPGCR) to switch between REF30 and CREF for capstan phase control.

**(3) Reference Period Register 2 (CRF)**

Bit :	15	14	13	12	11	10	9	8	7	6	5	4	3	2	1	0
	CRF15	CRF14	CRF13	CRF12	CRF11	CRF10	CRF9	CRF8	CRF7	CRF6	CRF5	CRF4	CRF3	CRF2	CRF1	CRF0
Initial value :	1	1	1	1	1	1	1	1	1	1	1	1	1	1	1	1
R/W :	W	W	W	W	W	W	W	W	W	W	W	W	W	W	W	W

The reference period register 2 (CRF) is a 16-bit write-only buffer register which generates the reference signals to control the capstan phase (CREF). CRF is accessibly by a word only. If a read is attempted, an undetermined value is read out. The value set in CRF should be 1/2 of the desired reference signal period.

When data is written in CRF, it is stored in the buffer once, and then fetched into CRF by a match signal of the comparator. (The data which generates the reference signal is updated from time to time by the match signal.) An enforced write, such as initial setting, etc., should be done by a dummy read of CRF.

If a byte-write in CRF is attempted, no operation is assured. CRF is initialized to H'FFFF by a reset, stand-by, or module stop.

Use bit 4 (CR/RF bit) in the capstan phase error detection control register (CPGCR) to switch between REF30 and CREF for capstan phase control. (See section 28.9, Capstan Phase Error Detector)

**(4) REF30 Counter Register (RFC)**

Bit :	15	14	13	12	11	10	9	8	7	6	5	4	3	2	1	0
	RFC15	RFC14	RFC13	RFC12	RFC11	RFC10	RFC9	RFC8	RFC7	RFC6	RFC5	RFC4	RFC3	RFC2	RFC1	RFC0
Initial value :	0	0	0	0	0	0	0	0	0	0	0	0	0	0	0	0
R/W :	R/W	R/W	R/W	R/W	R/W	R/W	R/W	R/W	R/W	R/W	R/W	R/W	R/W	R/W	R/W	R/W

The REF30 counter register (RFC) is a register which determines the initial value of the free-run counter when it generates REF30 signals when in playback. When data is written in RFC, its value is written in the counter by a match signal of the comparator. If bit 1 (VST) in RFM is set to 1, the counter is set by the Video FF signal when the drum phase is in FIX ON. The counter setting by the Video FF signal should be done by setting RFM's bit 1 (VST) and bit 0 (VEG). Don't set the RFC value at a value greater than 1/2 of the reference period register 1 (RFD).

RFC is a read/write register. If a read is attempted, the value of the counter is read out. If a byte-access is attempted, no operation is assured. RFC is initialized to H'0000 by a reset, stand-by, or module stop.

**(5) Reference Period Mode Register 2 (RFM2)**

Bit :	7	6	5	4	3	2	1	0
	(TBC)	—	—	—	—	—	—	FDS
Initial value :	1	1	1	1	1	1	1	0
R/W :	(R/W)*	—	—	—	—	—	—	R/W

Note: \* Writable only in the H8S/2194C Group.

RFM2 is an 8-bit read/write register which determines the operational state of the reference signal generators. Bits 6 to 1 are reserved. If a read is attempted, an undetermined value is read out. It is initialized to H'FE by a reset, stand-by or module stop. RFM2 is a byte access-only register; if accessed by a word, no operation is assured.

**Bit 7—TBC Selection Bit (TBC):** Selects whether the reference signals are generated by VD or in free-run in PB mode.

**Bit 7**

TBC	Description
0	Reference signals are generated by VD (This function is effective only in the H8S/2194C Group)
1	Reference signals are generated in free-run (Initial value)

**Bits 6 to 1—Reserved:** No write is valid. If a read is attempted, an undetermined value is read out.

**Bit 0—Field Selection Bit (FDS):** Determines whether selection between ODD or EVEN is made for the field signals when PB mode was switched over to REC mode, or these signals are synchronized with VD signals within phase error of 90° immediately after the switching over.

**Bit 0**

FDS	Description
0	Generated by the VD signal of ODD or EVEN selected (Initial value)
1	Generated by the VD signal within mode transition phase error of 90°

### 28.3.5 Description of Operation

#### (1) Operation of REF30 Signal Generators

The REF30 signal generators generate the reference signals required to control the phase of the drum and capstan.

To generate REF30 signals, set the half-period value to the reference period register 1 (RFD) corresponding to the 50% duty cycle. When in playback, REF30 signals are generated by operating REF30 signal generator in free-run. The generator has the external signal synchronization function built-in, and if bit 4 (REX) of the reference period mode register (RFM) is set to 1, it generates REF30 signals from external signals (EXTTRG).

In record mode, the reference signals are generated from the VD signal generated in the sync signal detection circuit. Any VD drop-out caused by weak field intensity, etc., is compensated by a set value of RFD. To cope with the VD noises, the generator performs automatically the VD masking for a time period about 75% of the RFD setting after REF30 signal was changed due to VD. In record mode, the generation of the reference signals either by VD or free-run operation can be controlled automatically or by software, using the V noise detection signal detected in the sync signal detection circuit. Select which is used by setting bit 6 (VNA) or 5 (CVS) of RFM.

The phase of the toggle output of the REF30 signal is cleared to L level when the signal mode transits from PB to REC (ASM). Also the frame servo function can be set, allowing to control the phase of REF30 signals with the field signal detected in the sync signal detection circuit. Use bit 2 (OD/EV) of RFM for such control.

See section 28.13.5(2), CTL Mode Register (CTLM), as for switching over between PB, ASM and REC.

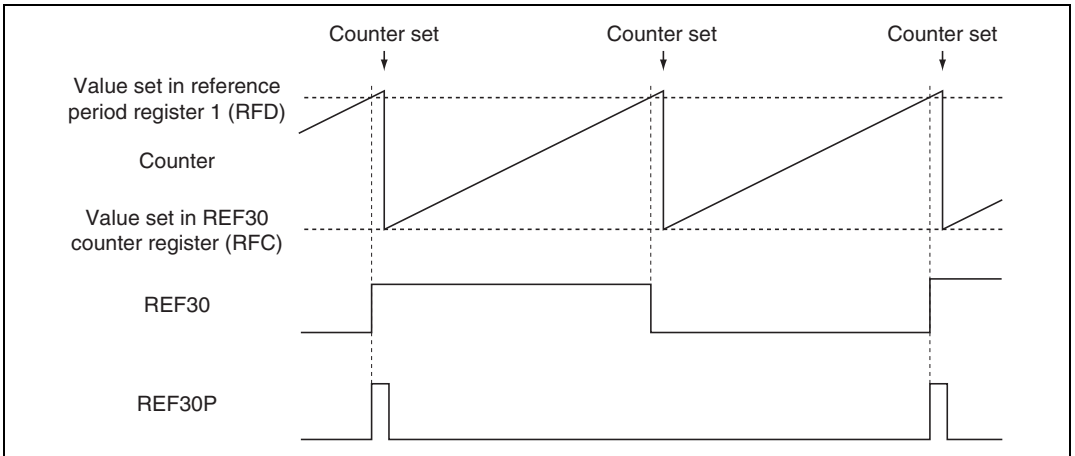
#### (2) Operation of the Mask Circuit

The REF30 signal generators have a toggle mask circuit and counter mask (counter set signal mask) circuit built-in. Each mask circuit masks irregular VD signals which may occur when the VD signal is unstable because of weak field intensity, etc., in record mode.

The toggle mask and counter mask circuits mask the VD automatically for about 75% of double the time period set in the reference period register 1 (RFD) after a VD signal was detected (see figure 28.9). If a VD signal dropped out and V was compensated, the toggle mask circuit begins masking. The counter mask circuit does not do so for about 25% of the time period. If a VD signal was detected during such time period, it does masking for about 75% of the time period. If not detected, it does for the same time period after V was compensated (see figures 28.10 and 28.11).

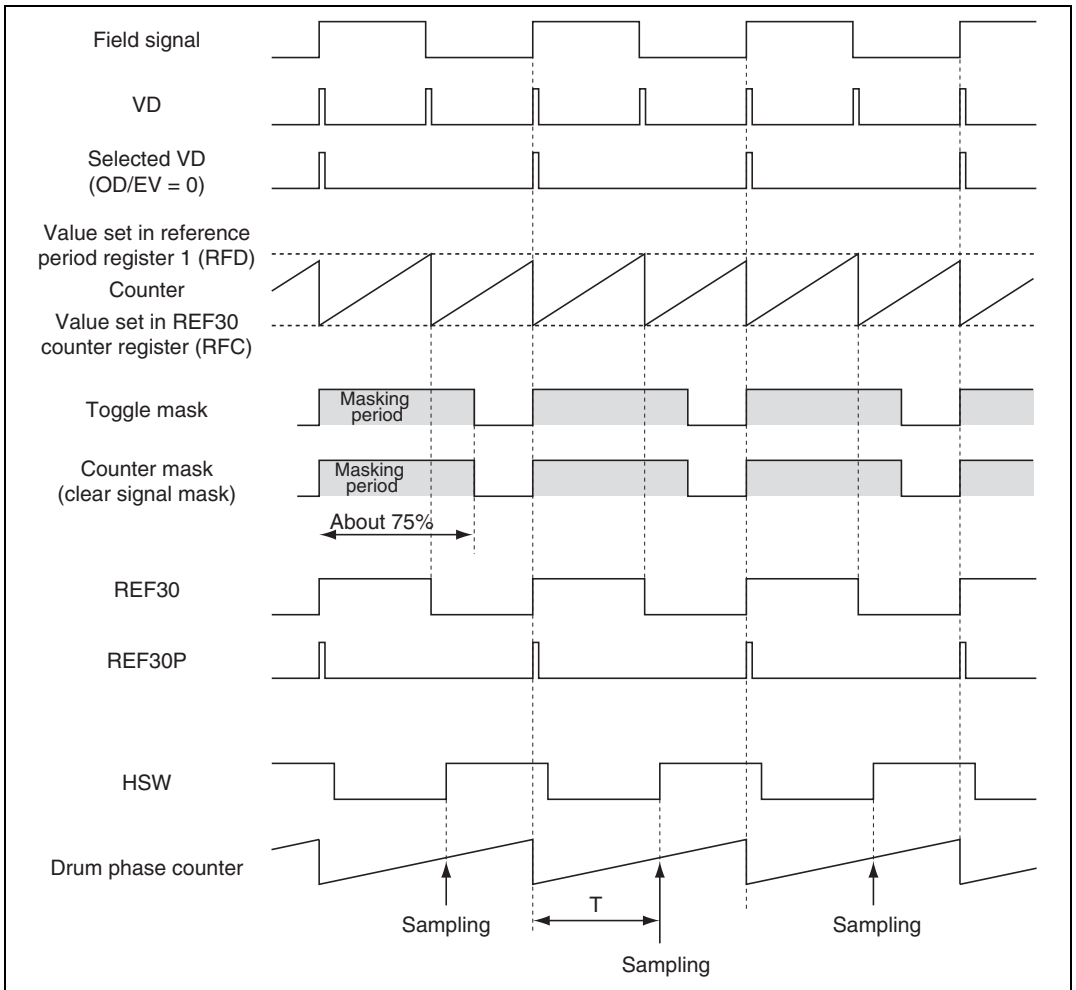
### (3) Timing of the REF30 Signal Generation

Figures 28.8, 28.9, 28.10, 28.11, and 28.12 show the timing of the generation of REF30 and REF30P signals.

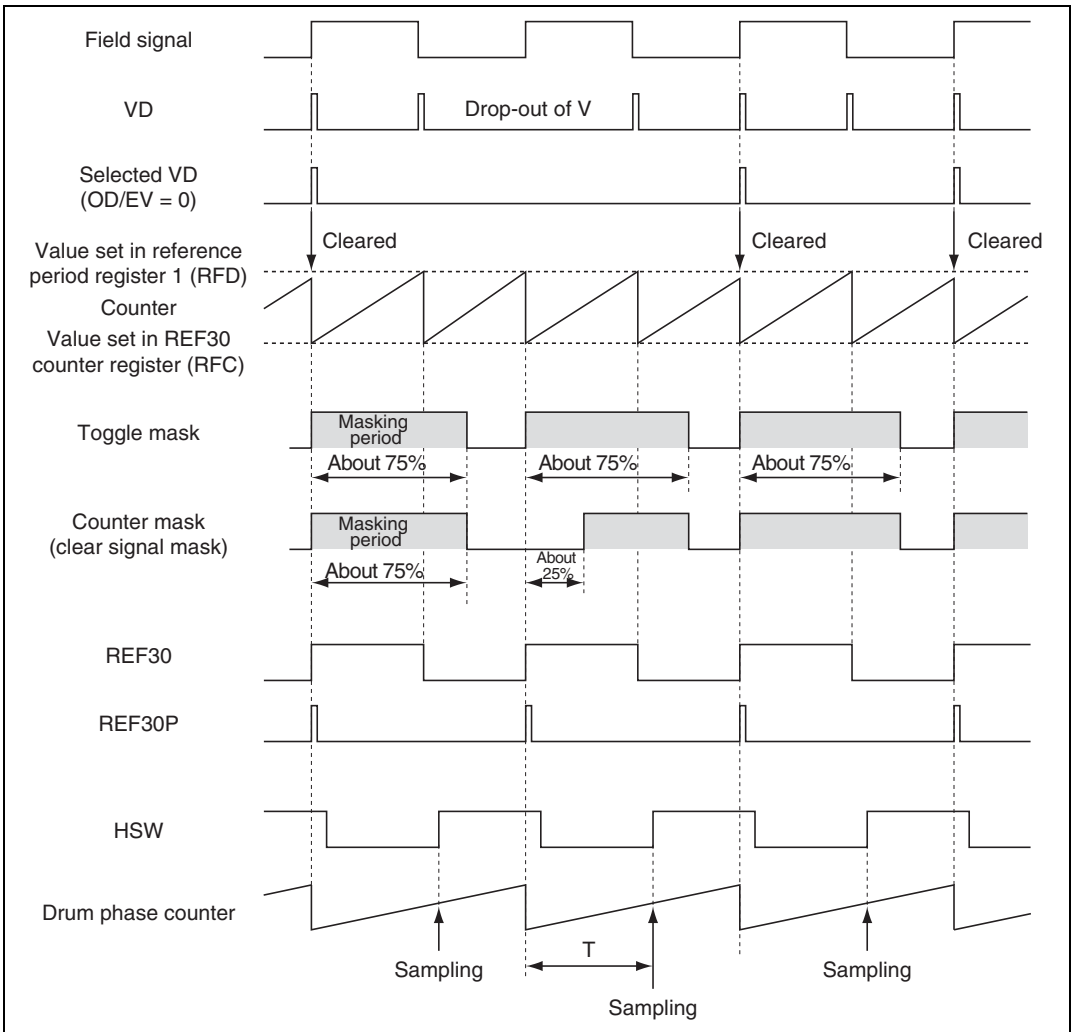


**Figure 28.8 REF30 Signals in Playback Mode**

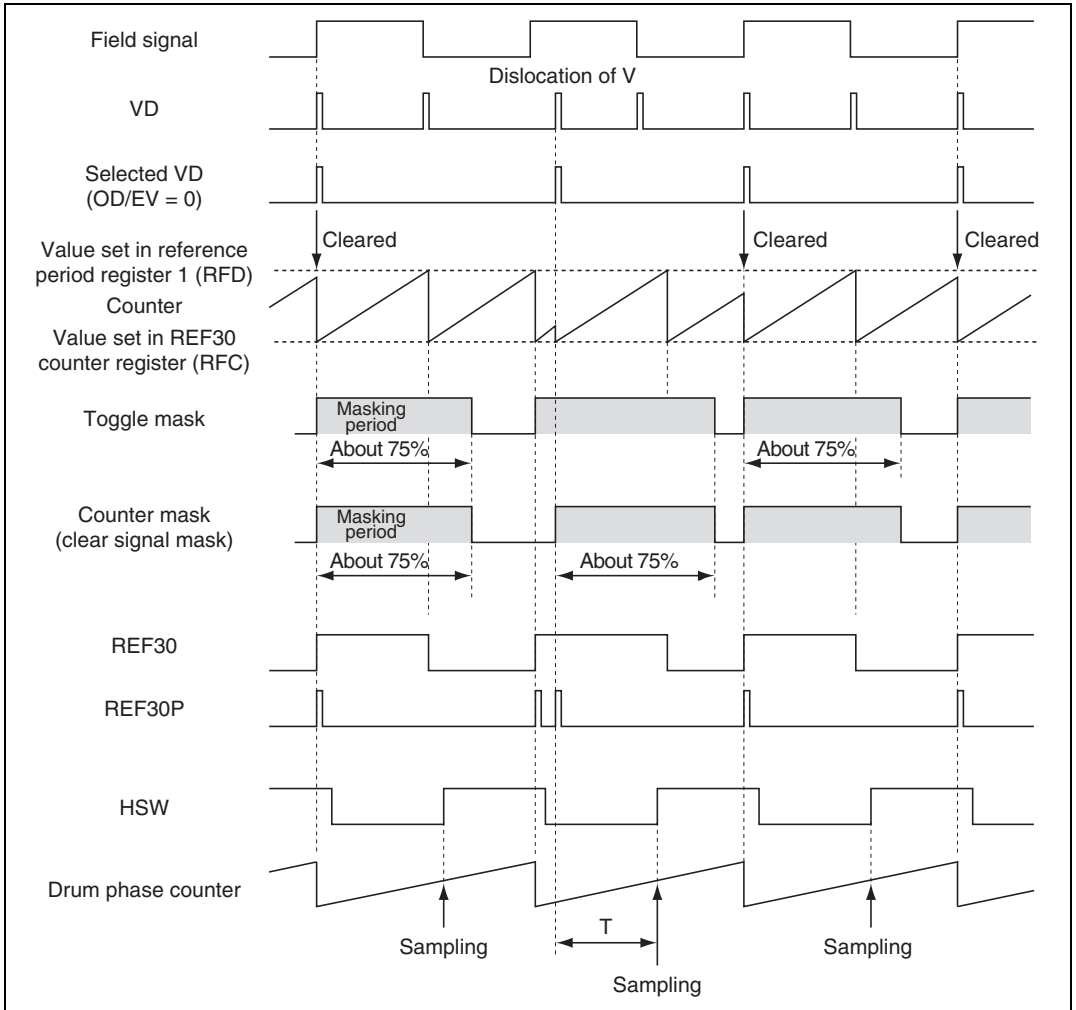




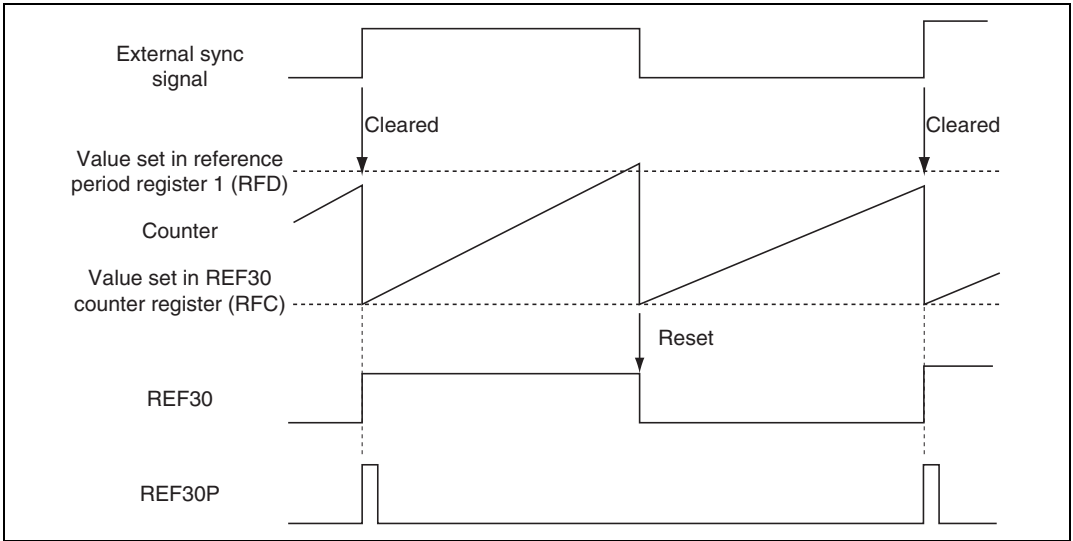
**Figure 28.9** Generation of Reference Signal in Record Mode (Normal Operation)



**Figure 28.10** Generation of Reference Signal in Record Mode (V Dropped Out)



**Figure 28.11 Generation of Reference Signal in Record Mode (V Dislocated)**



**Figure 28.12 Generation of REF30 Signal by External Sync Signal**

#### (4) CREF Signal Generator

The CREF signal generator generates a CREF signal which is the reference signal to control the phase of the capstan.

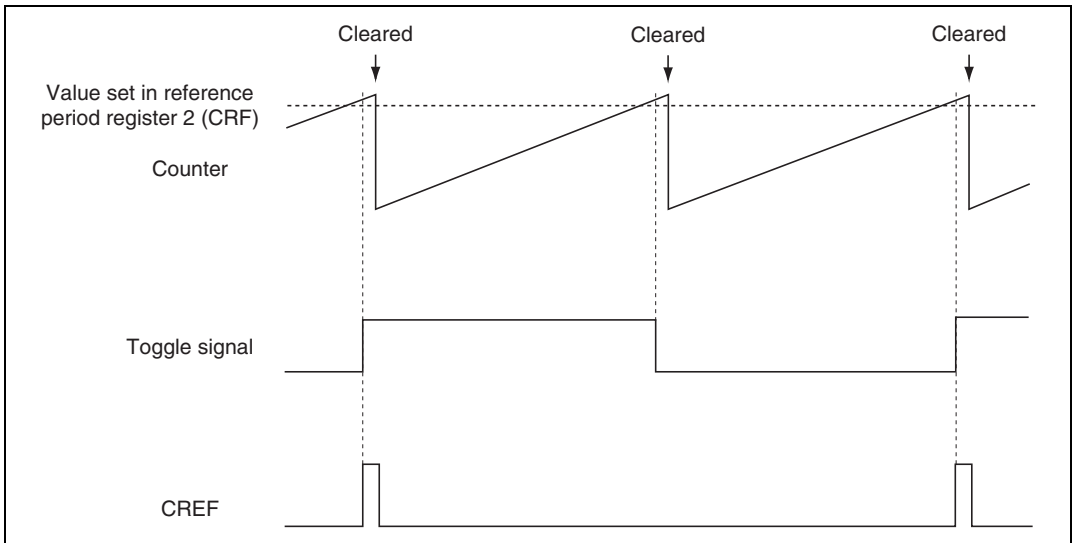
To generate CREF signals, set the half-period value to the reference period register 2 (CRF). If the set value matches the counter value, a toggle waveform is generated corresponding to the 50% duty cycle, and a one-shot pulse signal is output at the rising edge of the waveform. The counter of the CREF signal generator is initialized to H'0000 and the phase of the toggle is cleared to L level at the mode transition of PB (ASM) to REC. The timing of clearing is selectable between immediately after the transition from PB (ASM) to REC and the timing of DVCFG2 after the transition. Use bit 3 (CRD) of the reference period mode register (RFM) for the selection.

In the capstan phase error detection circuit, either the REF30 signal or CREF signal can be selected for the reference signal. Use either of them according to the use of the system.

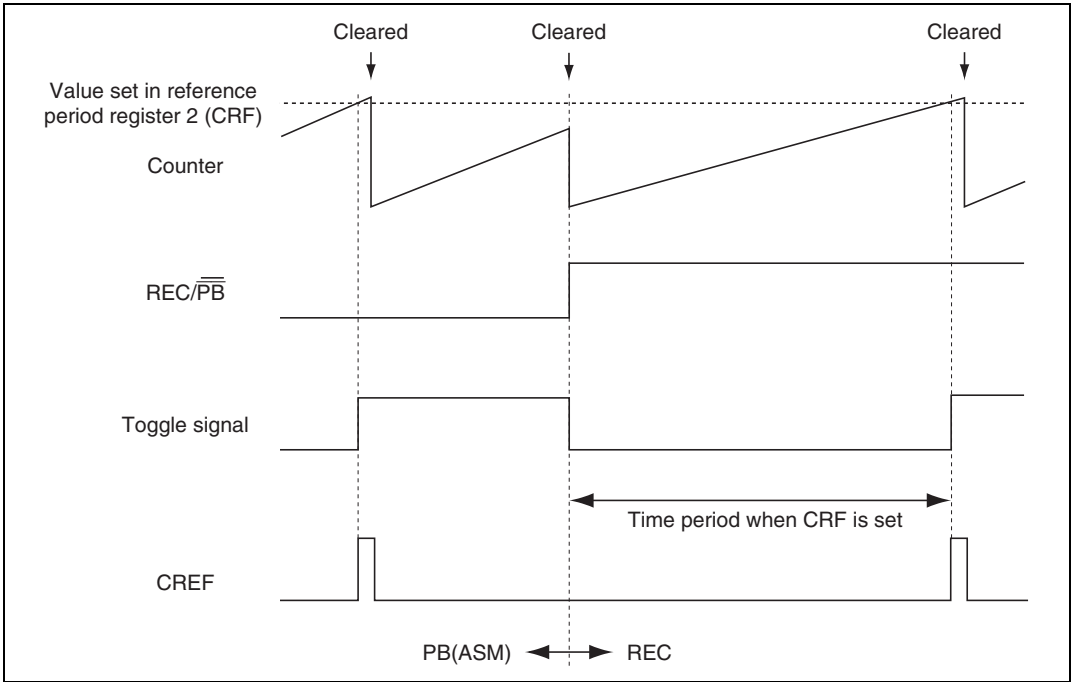
Use the CREF signal to control the phase of the capstan at a period which is different from the period used to control the phase of the drum. As for the switching between REF30 and CREF in the capstan phase control, see section 28.9.4 (3), Capstan Phase Error Detection Control Register (CPGCR).

### (5) Timing Chart of the CREF Signal Generation

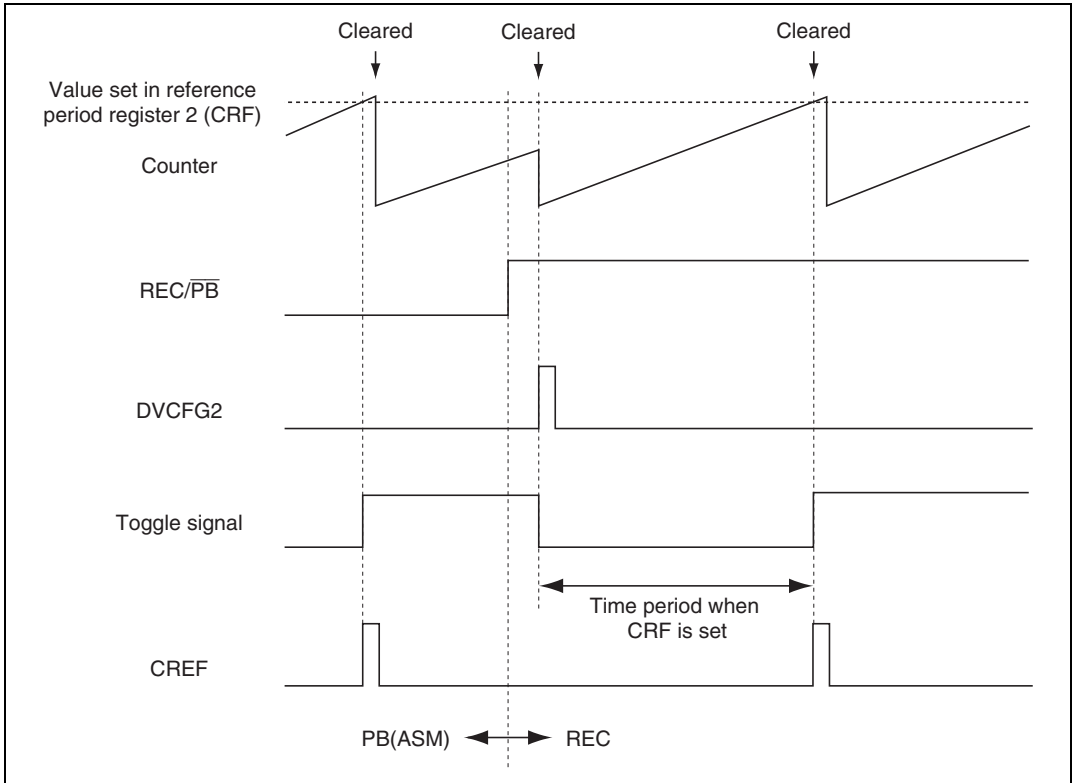
Figures 28.13, 28.14, and 28.15 show the generation of the CREF signal.



**Figure 28.13** Generation of CREF Signal

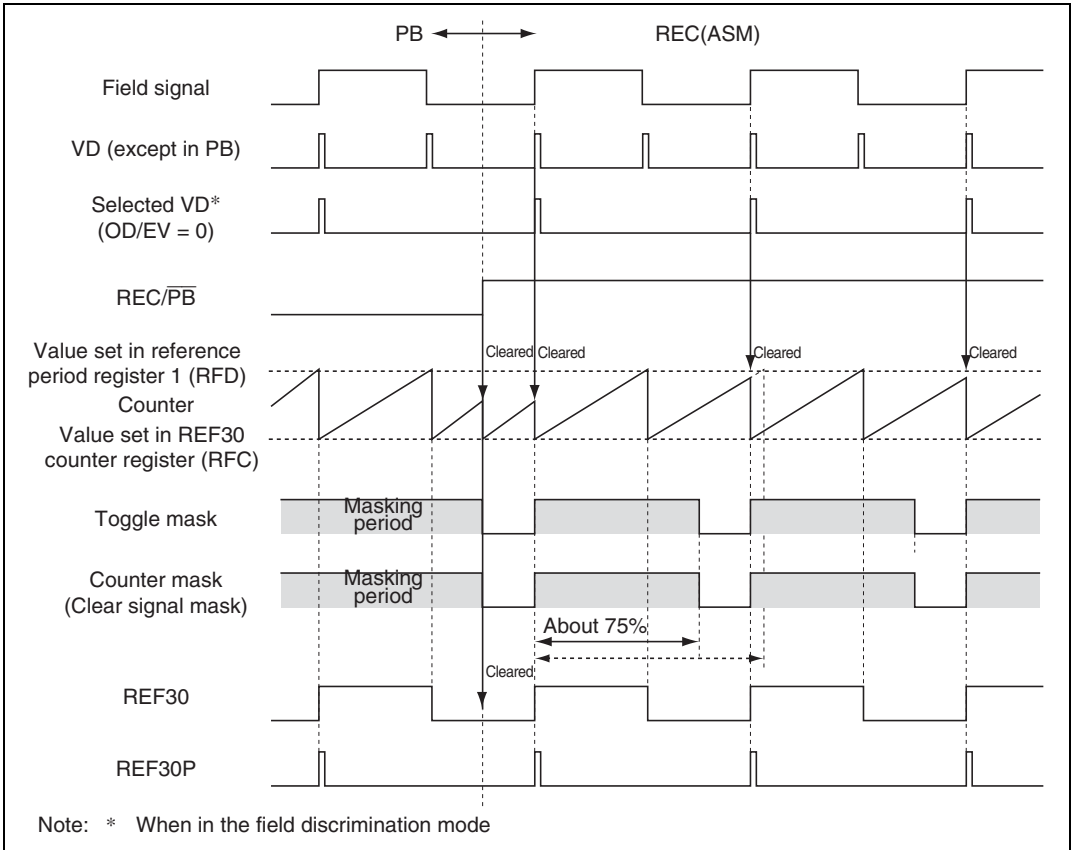


**Figure 28.14 CREF Signal when PB Is Switched to REC (when CRD Bit = 0)**



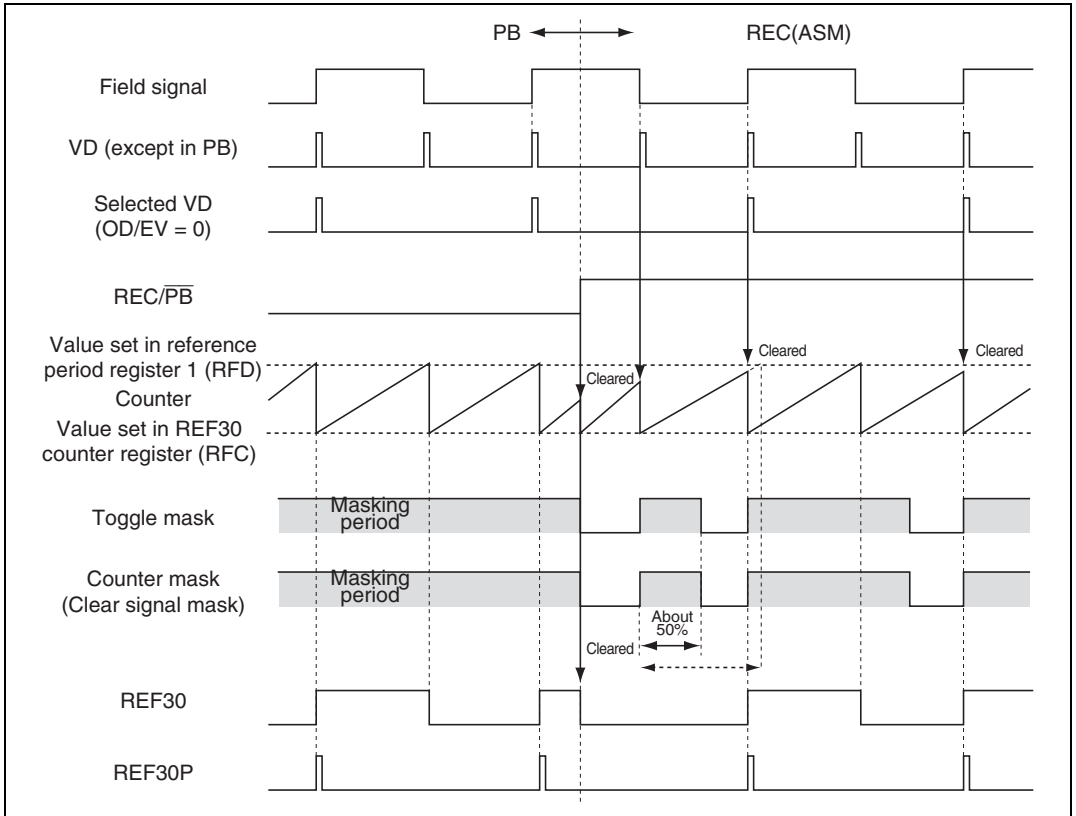
**Figure 28.15 CREF Signal when PB Is Switched to REC (when CRD Bit = 1)**

Figures 28.16 and 28.17 show REF30 (REF30P) when PB is switched to REC.



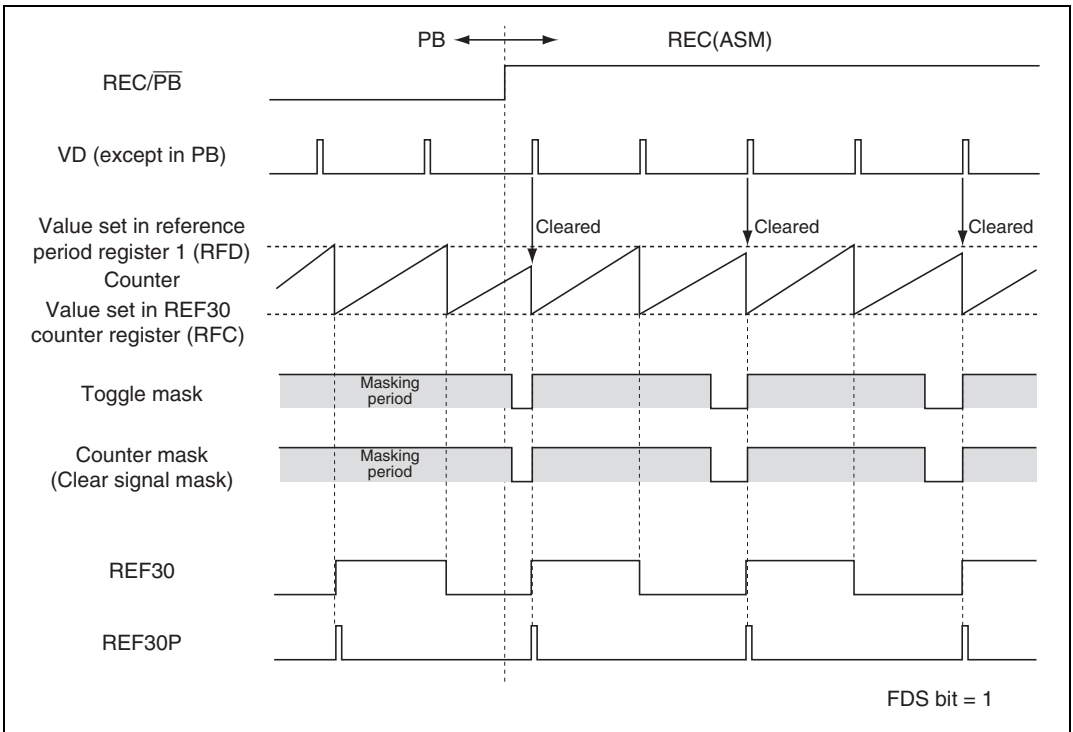
**Figure 28.16 Generation of the Reference Signal when PB Is Switched to REC (1)**



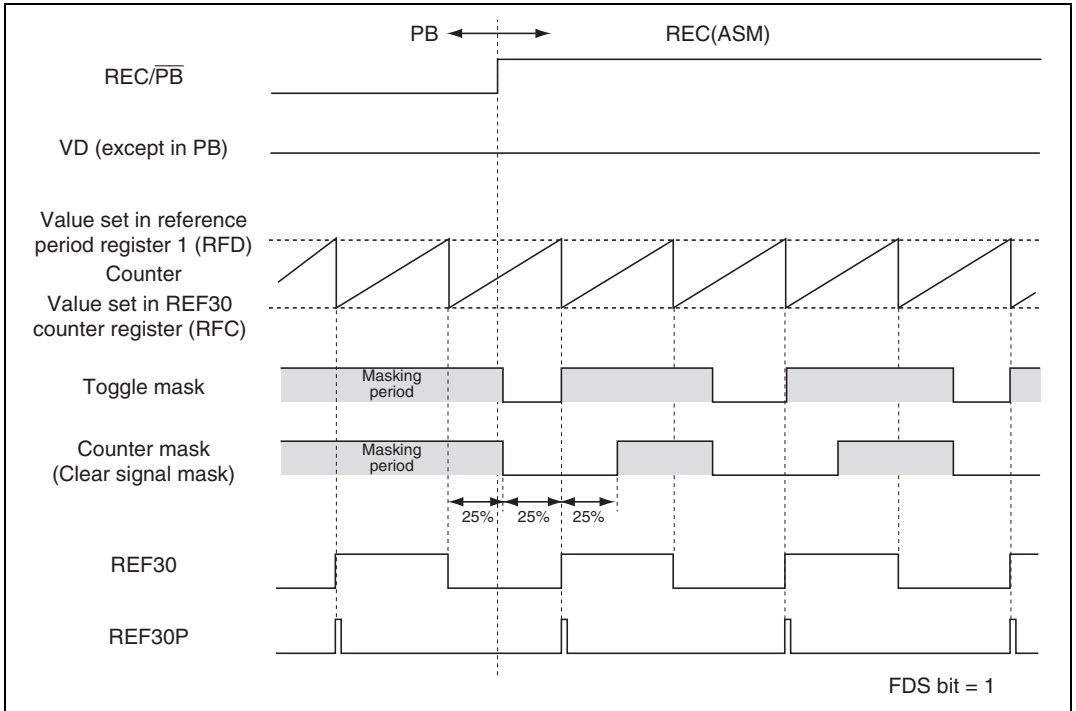


**Figure 28.17** Generation of the Reference Signal when PB Is Switched to REC (2)

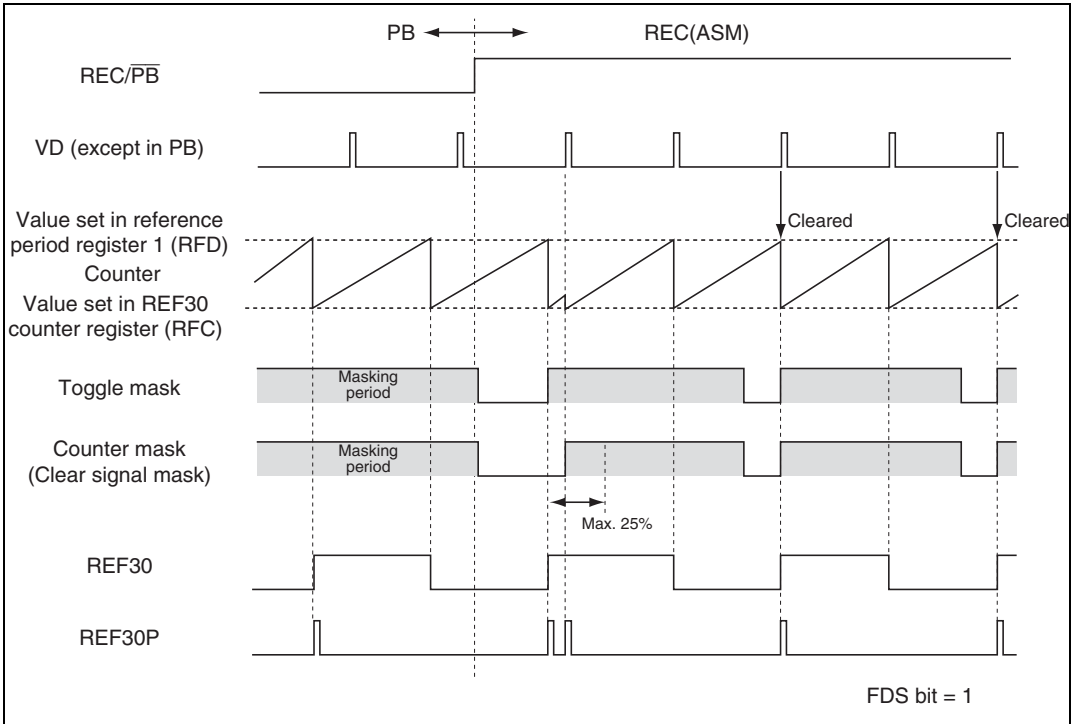
Figures 28.18, 28.19, 28.20, and 28.21 show REF30 (REF30P) when PB is switched to REC (where FDS bit = 1).



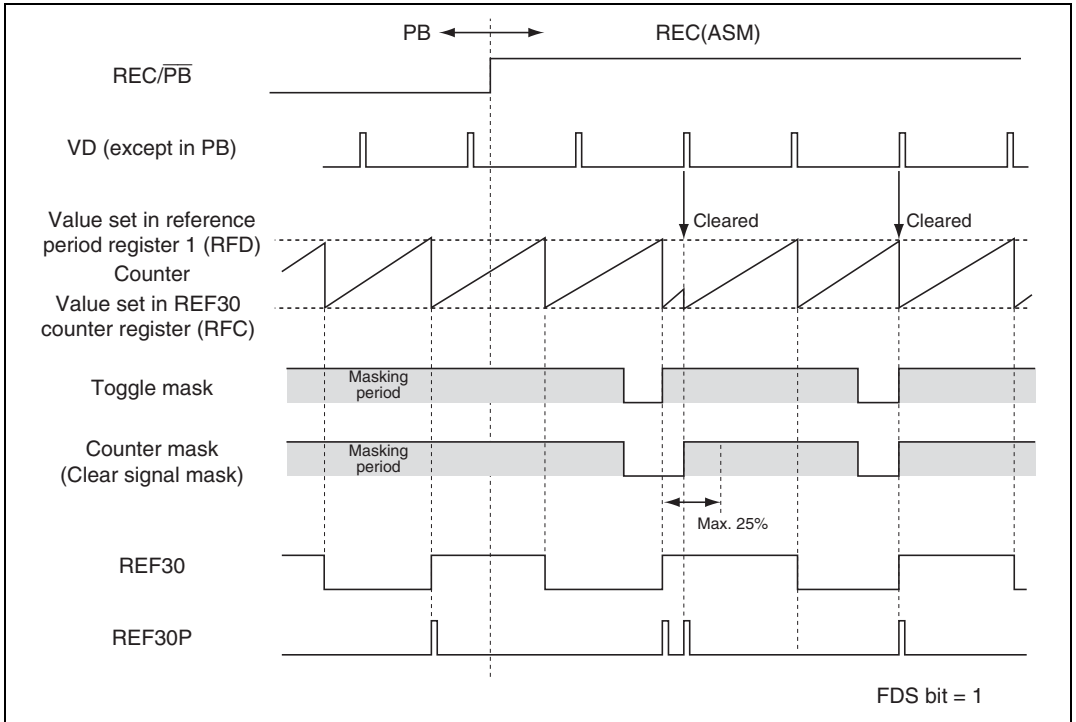
**Figure 28.18** Generation of the Reference Signal when PB Is Switched to REC where RFD Bit Is 1 (1)



**Figure 28.19** Generation of the Reference Signal when PB Is Switched to REC where RFD Bit Is 1 (when VD Signal Is Not Detected) (2)



**Figure 28.20 Generation of the Reference Signal when PB Is Switched to REC where RFD Bit Is 1 (3)**



**Figure 28.21** Generation of the Reference Signal when PB Is Switched to REC where RFD Bit Is 1 (4)

## 28.4 HSW (Head-Switch) Timing Generator

### 28.4.1 Overview

The HSW timing generator consists of one 5-bit counter and one 16-bit counter, matching circuit, and two 31-bit 10-stage FIFOs.

The 5-bit counter counts the DFG pulses following a DPG pulse. Each of them determines the timing to reset the 16-bit timer for each field. The matching circuit compares the timing data in the most significant 16 bits of FIFO with the 16-bit timer, and controls the output of pattern data set in the least significant 15 bits of FIFO. The 16-bit timer is a timer clocked by a  $\phi$  s/4 clock source, and can be used as a PPG (Programmable Pattern Generator) as well as a free-running counter (FRC). If used as a free-running counter, it is cleared by overflow (FRCOVF) of the Prescaler unit. Accordingly, two free-running counter operate in sync.

### 28.4.2 Block Diagram

Figure 28.22 shows a block diagram of the HSW timing generator.

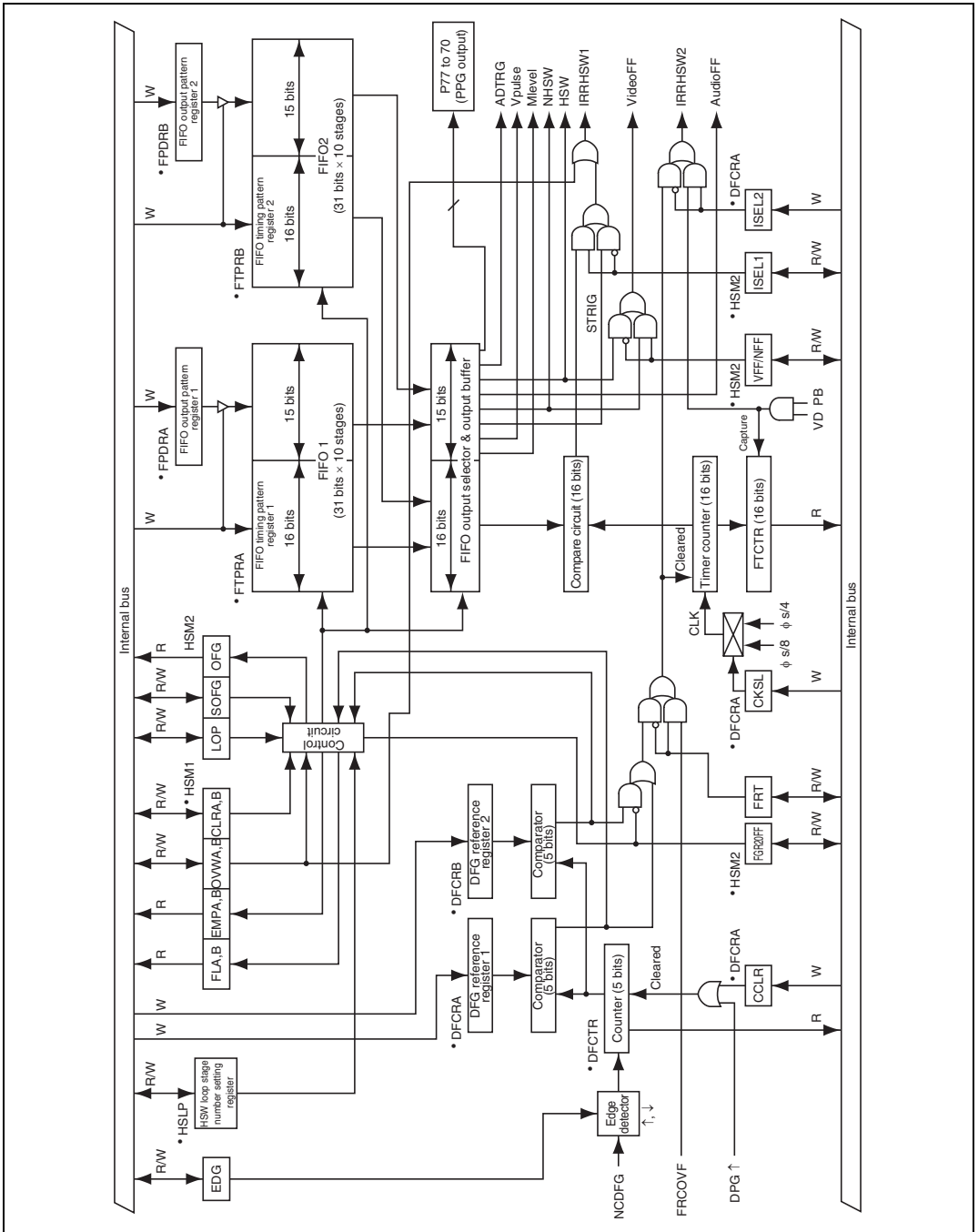


Figure 28.22 Composition of the HSW Timing Generator

### 28.4.3 Composition

The HSW timing generator is composed of the elements shown in table 28.5.

**Table 28.5 Composition of the HSW Timing Generator**

Element	Function
HSW mode register 1 (HSM1)	Confirmation/determination of this circuits' operating status
HSW mode register 2 (HSM2)	Confirmation/determination of this circuits' operating status
HSW loop stage number setting register (HSLP)	Setting of number of loop stages in loop mode
FIFO output pattern register 1 (FPDRA)	Output pattern data register of FIFO1
FIFO output pattern register 2 (FPDRB)	Output pattern data register of FIFO2
FIFO timing pattern register 1 (FTPRA)	Output timing register of FIFO1
FIFO timing pattern register 2 (FTPRB)	Output timing register of FIFO2
DFG reference register 1 (DFCRA)	Setting of reference DFG edge for FIFO1
DFG reference register 2 (DFCRB)	Setting of reference DFG edge for FIFO2
FIFO timer capture register (FTCTR)	Capture register of timer counter
DFG reference count register (DFCTR)	DFG edge count
FIFO control circuit	Controls FIFO status
DFG count compare circuit (×2)	Detection of match between DFCR and DFG counters
16-bit timer counter	16-bit free-run timer counter
31-bit × 20 stage FIFO	First In First Out data buffer
31-bit FIFO data buffer	Data storing buffer for the first stage of FIFO
16-bit compare circuit	Detection of match between timer counter and FIFO data buffer

FPDRA and FPDRB are intermediate buffers; an FTPRA and FTPRB write results in simultaneous writing of all 31 bits to the FIFO. The FIFO has two 31-bit × 10-stage data buffers, its operating status being controlled by HSM1 and HSM2. Data is stored in the 31-bit data buffer. The values of FTPRA, FTPRB and the timer counter are compared, and if they match, the 15-bit pattern data is output to each function. AudioFF, VideoFF and PPG (P70 to P77) are pin outputs, ADTRG is the A/D converter hardware start signal, Vpulse and Mlevel signals are the signals to generate the additional V pulses, and HSW and NHSW signals are the same with VideoFF signals used for the phase control of the drum. In free-run mode (when FRT bit of HSM2 = 1), the 16-bit



timer counter is initialized when the prescaler unit overflows, or by a signal indicating a match between DFCRA, DFCRB and the DFG counter in DFG reference mode.

### 28.4.4 Register Configuration

Table 28.6 shows the register configuration of the HSW timing generator.

**Table 28.6 Register Configuration**

Name	Abbrev.	R/W	Size	Initial Value	Address
HSW mode register 1	HSM1	R/W	Byte	H'30	H'FD060
HSW mode register 2	HSM2	R/W	Byte	H'00	H'FD061
HSW loop stage number setting register	HSLP	R/W	Byte	Undetermined	H'FD062
FIFO output pattern register 1	FPDRA	W	Word	Undetermined	H'FD064
FIFO timing pattern register 1*	FTPRA	W	Word	Undetermined	H'FD066
FIFO output pattern register 2	FPDRB	W	Word	Undetermined	H'FD068
FIFO timing pattern register 2	FTPRB	W	Word	Undetermined	H'FD06A
DFG reference register 1*	DFCRA	W	Byte	Undetermined	H'FD06C
DFG reference register 2	DFCRB	W	Byte	Undetermined	H'FD06D
FIFO timer capture register*	FTCTR	R	Word	H'0000	H'FD066
DFG reference count register*	DFCTR	R	Byte	H'E0	H'FD06C

Note: \* FTPRA and FTCTR, as well as DFCRA and DFCTR, are allocated to the same addresses.

### 28.4.5 Register Descriptions

#### (1) HSW Mode Register 1 (HSM1)

Bit :	7	6	5	4	3	2	1	0
	FLB	FLA	EMPB	EMPA	OVWB	OVWA	CLRB	CLRA
Initial value :	0	0	1	1	0	0	0	0
R/W :	R	R	R	R	R/(W)*	R/(W)*	R/W	R/W

Note: \* Only 0 can be written

HSM1 is a register which confirms and determines the operational state of the HSW timing generator.

HSM1 is an 8-bit register. Bits 7 to 4 are read-only bits, and write is disabled. All the other bits accept both read and write. It is initialized to H'30 by a reset or stand-by.

**Bit 7—FIFO2 Full Flag (FLB):** When the FLB bit is 1, it indicates that the timing pattern data and the output pattern data of FIFO2 are full. If a write is attempted in this state, the write operation becomes invalid, an interrupt is generated, the OVWB flag (bit 3) is set to 1, and the write data is lost. Wait until space becomes available in the FIFO2, then write again.

**Bit 7**

FLB	Description	
0	FIFO2 is not full, and can accept data input	(Initial value)
1	FIFO2 is full	

**Bit 6—FIFO1 Full Flag (FLA):** When the FLA bit is 1, it indicates that the timing pattern data and the output pattern data of FIFO1 are full. If a write is attempted in this state, the write operation becomes invalid, an interrupt is generated, the OVWA flag (bit 2) is set to 1, and the write data is lost. Wait until space becomes available in the FIFO1, then write again.

**Bit 6**

FLA	Description	
0	FIFO1 is not full, and can accept data input	(Initial value)
1	FIFO1 is full	

**Bit 5—FIFO2 Empty Flag (EMPB):** Indicates that FIFO2 has no data, or that all the data has been output in single mode.

**Bit 5**

EMPB	Description	
0	FIFO2 contains data	
1	FIFO2 contains no data	(Initial value)

**Bit 4—FIFO1 Empty Flag (EMPA):** Indicates that FIFO1 has no data, or that all the data has been output in single mode.

**Bit 4**

EMPA	Description	
0	FIFO1 contains data	
1	FIFO1 contains no data	(Initial value)

**Bit 3—FIFO2 Overwrite Flag (OVWB):** If a write is attempted when the timing pattern data and the output pattern data of FIFO2 are full (FLB bit = 1), the write operation becomes invalid, an interrupt is generated, the OVWB flag is set to 1, and the write data is lost. Wait until space becomes available in the FIFO2, then write again.

Write 0 to clear the OVWB flag, because it is not cleared automatically.

### Bit 3

OVWB	Description
0	Normal operation (Initial value)
1	Indicates that a write in FIFO2 was attempted when FIFO2 was full. Clear this flag by 0 writing

**Bit 2—FIFO1 Overwrite Flag (OVWA):** If a write is attempted when the timing pattern data and the output pattern data of FIFO1 are full (FLA bit = 1), the write operation becomes invalid, an interrupt is generated, the OVWA flag is set to 1, and the write data is lost. Wait until space becomes available in the FIFO1, then write again.

Write 0 to clear the OVWA flag, because it is not cleared automatically.

### Bit 2

OVWA	Description
0	Normal operation (Initial value)
1	Indicates that a write in FIFO1 was attempted when FIFO1 was full. Clear this flag by 0 writing

**Bit 1—FIFO2 Pointer Clear (CLRB):** Clears the FIFO2 write position pointer. After 1 is written, the bit immediately reverts to 0. Writing 0 in this bit has no effect.

### Bit 1

CLRB	Description
0	Normal operation (Initial value)
1	Clears the FIFO2 pointer

**Bit 0—FIFO1 Pointer Clear (CLRA):** Clears the FIFO1 write position pointer. After 1 is written, the bit immediately reverts to 0. Writing 0 in this bit has no effect.

**Bit 0**

CLRA	Description	
0	Normal operation	(Initial value)
1	Clears the FIFO1 pointer	

**(2) HSW Mode Register 2 (HSM2)**

Bit :	7	6	5	4	3	2	1	0
	FRT	FGR2OFF	LOP	EDG	ISEL1	SOFG	OFG	VFF/NFF
Initial value :	0	0	0	0	0	0	0	0
R/W :	R/W	R	R/W	R/W	R/W	R/W	R	W

HSM2 is a register which confirms and determines the operational state of the HSW timing generator.

HSM2 is an 8-bit register. Bits 6 and 1 are read-only bits, and write is disabled. Bit 0 is a write-only bit, and if a read is attempted, an undetermined value is read out. All the other bits accept both read and write. It is initialized to H'00 by a reset or stand-by.

**Bit 7—Free-Run Bit (FRT):** Selects whether timing is matched to the DPG counter and timer, or to free-running counter.

**Bit 7**

FRT	Description	
0	5-bit DFG counter + 16-bit timer counter	(Initial value)
1	16-bit FRC	

**Bit 6—FRG2 Clear Stop Bit (FGR2OFF):** Nullifies the clearing of the counter by the DFG reference register 2. The FIFO group, including both FIFO1 and FIFO2, is available.

**Bit 6**

FGR2OFF	Description	
0	Validates the clearing of the 16-bit timer counter by DFG reference register 2	(Initial value)
1	Nullifies the clearing of the 16-bit timer counter by DFG reference register 2	

**Bit 5—Mode Selection Bit (LOP):** Selects the output mode of FIFO. If the loop mode is selected, LOB3 to LOB0 bits and LOA3 to LOA0 bits become valid. If the LOP bit is rewritten, the pointer which counts the writing position of FIFO is cleared. In this case, the ultimate output date is kept.

**Bit 5**

<b>LOP</b>	<b>Description</b>
0	Single mode (Initial value)
1	Loop mode

**Bit 4—DFG Edge Selection Bit (EDG):** Selects the edge by which to count DFG.

**Bit 4**

<b>EDG</b>	<b>Description</b>
0	Counts by the rising edge of DFG (Initial value)
1	Counts by the falling edge of DFG

**Bit 3—Interrupt Selection Bit (ISEL1):** Selects the factor which causes an interrupt. (IRRHSW1)

**Bit 3**

<b>ISEL1</b>	<b>Description</b>
0	Generates an interrupt request by the rising edge of the STRIG signal of FIFO (Initial value)
1	Generates an interrupt request by the matching signal of FIFO

**Bit 2—FIFO Output Group Selection Bit (SOFG):** Selects whether 20 stages of FIFO1 + FIFO2 or only 10 stages of FIFO1 are used.

If 20-stage output mode is used in single mode, data write in FIFO1 and FIFO2 is required. Monitor the output FIFO group flag (OFG) and control it by software. Output all the data of FIFO2 after all the data of FIFO1 was output. Repeat this step again. If 10-stage output mode is used, the data of FIFO2 is not reflected.

Rewriting the SOFG bit 0 → 1 → 0 initializes the control signal of the FIFO output stage to the FIFO1 side.

#### Bit 2

SOFG	Description	
0	20-stage output of FIFO1 + FIFO2	(Initial value)
1	10-stage output of FIFO1 only	

**Bit 1—Output FIFO Group Flag (OFG):** Indicates the FIFO group which is outputting.

#### Bit 1

OFG	Description	
0	Pattern is being output by FIFO1	(Initial value)
1	Pattern is being output by FIFO2	

**Bit 0—Output Switching Bit between VideoFF and NarrowFF (VFF/NFF):** Switches the signal output to the VideoFF pin.

#### Bit 0

VFF/NFF	Description	
0	VideoFF output	(Initial value)
1	NarrowFF output	

**(3) HSW Loop Stage Number Setting Register (HSLP)**

Bit :	7	6	5	4	3	2	1	0
	LOB3	LOB2	LOB1	LOB0	LOA3	LOA2	LOA1	LOA0
Initial value :	*	*	*	*	*	*	*	*
R/W :	R/W	R/W	R/W	R/W	R/W	R/W	R/W	R/W

Note: \* Undetermined

HSLP sets the number of the loop stages when the HSW timing generator is in loop mode. It is valid if bit 5 (LOP) of HSM2 is 1. Bits 7 to 4 set the number of FIFO2 stages. Bits 3 to 0 set the number of FIFO1 stages.

HSLP is an 8-bit read/write register. It is not initialized by a reset, stand-by or module stop, accordingly be sure to set the number of the stages when the loop mode is used.

**Bits 7 to 4—FIFO2 Stage Number Setting Bits (LOB3 to LOB0):** Set the number of FIFO2's stages in loop mode. They are valid only if the loop mode is set (LOP bit of HSM2 is 1).

**HSM2 HSLP**

Bit 5	Bit 7	Bit 6	Bit 5	Bit 4	Description				
LOP	LOB3	LOB2	LOB1	LOB0					
0	*	*	*	*	Single mode (Initial value)				
1	0	0	0	0	Only 0th stage of FIFO2 is output				
				1	0th and 1st stages of FIFO2 are output				
				1	0	0th to 2nd stages of FIFO2 are output			
				1	0th to 3rd stages of FIFO2 are output				
				1	0	0	0	0th to 4th stages of FIFO2 are output	
							1	0th to 5th stages of FIFO2 are output	
							1	0	0th to 6th stages of FIFO2 are output
							1	0th to 7th stages of FIFO2 are output	
				1	0	0	0	0th to 8th stages of FIFO2 are output	
							1	0th to 9th stages of FIFO2 are output	
							1	0	Setting prohibited
							1	0	Setting prohibited
				1	0	0	0	Setting prohibited	
							1	0	Setting prohibited
1	0	Setting prohibited							
1	0	Setting prohibited							

Legend: \* Don't care.



**Bits 3 to 0—FIFO1 Stage Number Setting Bits (LOA3 to LOA0):** Set the number of FIFO1's stages in loop mode. They are valid only if the loop mode is set (LOP bit of HSM2 is 1).

HSM2		HSLP			Description				
Bit 5	Bit 3	Bit 2	Bit 1	Bit 0					
LOP	LOA3	LOA2	LOA1	LOA0					
0	*	*	*	*	Single mode (Initial value)				
1	0	0	0	0	Only 0th stage of FIFO1 is output				
				1	0th and 1st stages of FIFO1 are output				
				1	0	0th to 2nd stages of FIFO1 are output			
				1	1	0th to 3rd stages of FIFO1 are output			
				1	0	0	0th to 4th stages of FIFO1 are output		
				1	1	0th to 5th stages of FIFO1 are output			
				1	0	0	0th to 6th stages of FIFO1 are output		
				1	1	0th to 7th stages of FIFO1 are output			
				1	0	0	0th to 8th stages of FIFO1 are output		
				1	1	0th to 9th stages of FIFO1 are output			
							1	0	Setting prohibited
								1	
						1	0	0	
								1	
			1	0					
				1					

Legend: \* Don't care.

**(4) FIFO Output Pattern Register 1 (FPDRA)**

Bit :	15	14	13	12	11	10	9	8
	—	ADTRGA	STRIGA	NarrowFFA	VFFA	AFFA	VpulseA	MlevelA
Initial value :	1	*	*	*	*	*	*	*
R/W :	—	W	W	W	W	W	W	W
Bit :	7	6	5	4	3	2	1	0
	PPGA7	PPGA6	PPGA5	PPGA4	PPGA3	PPGA2	PPGA1	PPGA0
Initial value :	*	*	*	*	*	*	*	*
R/W :	W	W	W	W	W	W	W	W

Note: \* Undetermined

FPDRA is a buffer register for the output pattern register of FIFO1. When the timing pattern is written in FTPRA the output pattern data written in FPDRA is written at the same time to the position pointed by the buffer pointer of FIFO1. Be sure to write the output pattern data in FPDRA before writing it in FTPRA.

FPDRA is a 16-bit write-only register. Only a word access is valid. If a byte access is attempted, resulting operation is not assured. No read is valid. If a read is attempted, an undetermined value is read out. It is not initialized by a reset, stand-by or module stop, accordingly be sure to write data before use.

**Bit 15—Reserved:** It cannot be written in or read out.

**Bit 14—A/D Trigger A Bit (ADTRGA):** A signal for starting the A/D converter hardware.

**Bit 13—S-TRIGA Bit (STRIGA):** A signal for generating an interrupt by pattern data. When STRIGA is selected by ISEL, pattern data changes from 0 to 1, and thus generates an interrupt.

**Bit 12—NarrowFFA Bit (NarrowFFA):** Controls the Narrow Video Head.

**Bit 11—VideoFFA Bit (VFFA):** Controls the Video Head.

**Bit 10—AudioFFA Bit (AFFA):** Controls the Audio Head.

**Bit 9—VpulseA Bit (VpulseA):** Used for generating an additional V signal. See section 28.12, Additional V Signal Generator, for more information.

**Bit 8—MlevelA Bit (MlevelA):** Used for generating an additional V signal. See section 28.12, Additional V Signal Generator, for more information.

**Bits 7 to 0—PPG Output Signal A Bits (PPGA7 to PPGA0):** Used for timing control output of port 7 (PPG).

**(5) FIFO Output Pattern Register 2 (FPDRB)**

Bit :	15	14	13	12	11	10	9	8
	—	ADTRGB	STRIGB	NarrowFFB	VFFB	AFFB	VpulseB	MlevelB
Initial value :	1	*	*	*	*	*	*	*
R/W :	—	W	W	W	W	W	W	W
Bit :	7	6	5	4	3	2	1	0
	PPGB7	PPGB6	PPGB5	PPGB4	PPGB3	PPGB2	PPGB1	PPGB0
Initial value :	*	*	*	*	*	*	*	*
R/W :	W	W	W	W	W	W	W	W

Note: \* Undetermined

FPDRB is a buffer register for the output pattern register of FIFO2. When the timing pattern is written in FTPRB the output pattern data written in FPDRB is written at the same time to the position pointed by the buffer pointer of FIFO2. Be sure to write the output pattern data in FPDRB before writing it in FTPRB.

FPDRB is a 16-bit write-only register. Only a word access is valid. If a byte access is attempted, resulting operation is not assured. No read is valid. If a read is attempted, an undetermined value is read out. It is not initialized by a reset, stand-by or module stop, accordingly be sure to write data before use.

**Bit 15—Reserved:** It cannot be written in or read out.

**Bit 14—A/D Trigger B Bit (ADTRGB):** A signal for starting the A/D converter hardware.

**Bit 13—S-TRIGB Bit (STRIGB):** A signal for generating an interrupt by pattern data. When STRIGB is selected by ISEL, pattern data changes from 0 to 1, and thus generates an interrupt.

**Bit 12—NarrowFFB Bit (NarrowFFB):** Controls the Narrow Video Head.

**Bit 11—VideoFFB Bit (VFFB):** Controls the Video Head.

**Bit 10—AudioFFB Bit (AFFB):** Controls the Audio Head.

**Bit 9—VpulseB Bit (VpulseB):** Used for generating an additional V signal. See section 28.12, Additional V Signal Generator, for more information.

**Bit 8—MlevelB Bit (MlevelB):** Used for generating an additional V signal. See section 28.12, Additional V Signal Generator, for more information.

**Bits 7 to 0—PPG Output Signal B Bits (PPGB7 to PPGB0):** Used for timing control output of port 7 (PPG).

**(6) FIFO Timing Pattern Register 1 (FTPRA)**

Bit : 15 14 13 12 11 10 9 8 7 6 5 4 3 2 1 0

FTPRA15	FTPRA14	FTPRA13	FTPRA12	FTPRA11	FTPRA10	FTPRA9	FTPRA8	FTPRA7	FTPRA6	FTPRA5	FTPRA4	FTPRA3	FTPRA2	FTPRA1	FTPRA0
---------	---------	---------	---------	---------	---------	--------	--------	--------	--------	--------	--------	--------	--------	--------	--------

Initial value : \* \* \* \* \* \* \* \* \* \* \* \* \* \* \*

R/W : W W W W W W W W W W W W W W W W

Note: \* Undetermined

FTPRA is a register to write the timing pattern data of FIFO1. The timing data written in FTPRA is written at the same time to the position pointed by the buffer pointer of FIFO1 together with the buffer data of FPDRA.

FTPRA is a 16-bit write-only register. Only a word access is valid. If a byte access is attempted, resulting operation is not assured. It is not initialized by a reset, stand-by or module stop, accordingly be sure to write data before use.

Note: Its address is shared with the FIFO timer capture register (FTCTR). Accordingly, the value of FTCTR is read out if a read is attempted.

**(7) FIFO Timing Pattern Register 2 (FTPRB)**

Bit : 15 14 13 12 11 10 9 8 7 6 5 4 3 2 1 0

FTPRB15	FTPRB14	FTPRB13	FTPRB12	FTPRB11	FTPRB10	FTPRB9	FTPRB8	FTPRB7	FTPRB6	FTPRB5	FTPRB4	FTPRB3	FTPRB2	FTPRB1	FTPRB0
---------	---------	---------	---------	---------	---------	--------	--------	--------	--------	--------	--------	--------	--------	--------	--------

Initial value : \* \* \* \* \* \* \* \* \* \* \* \* \* \* \*

R/W : W W W W W W W W W W W W W W W W

Note: \* Undetermined

FTPRB is a register to write the timing pattern data of FIFO2. The timing data written in FTPRB is written at the same time to the position pointed by the buffer pointer of FIFO2 together with the buffer data of FPDRB.

FTPRB is a 16-bit write-only register. Only a word access is valid. If a byte access is attempted, resulting operation is not assured. It is not initialized by a reset, stand-by or module stop, accordingly be sure to write data before use.

**(8) DFG Reference Register 1 (DFCRA)**

Bit :	7	6	5	4	3	2	1	0
	ISEL2	CCLR	CKSL	DFCRA4	DFCRA3	DFCRA2	DFCRA1	DFCRA0
Initial value :	0	0	0	*	*	*	*	*
R/W :	W	W	W	W	W	W	W	W

Note: \* Undetermined

DFCRA is a register which determines the operation of the HSW timing generator as well as the starting point of the timing of FIFO1.

DFCRA is an 8-bit write-only register. It is not initialized by a reset, stand-by or module stop, accordingly be sure to write data before use.

Note: Its address is shared with the DFG reference counter register (DFCTR). Accordingly, the value of DFCTR is read out in the low-order five bits if a read is attempted.

**Bit 7—Interrupt Selection Bit (ISEL2):** Selects the factor which causes an interrupt. (IRRHSW2)

**Bit 7**

ISEL2	Description
0	Generates an interrupt request by the clear signal of the 16-bit timer counter (Initial value)
1	Generates an interrupt request by the VD signal in PB mode

**Bit 6—DFG Counter Clear Bit (CCLR):** Enforces clearing of the 5-bit counter which counts DFG by software. Writing 1 returns 0 immediately. Writing 0 causes no effect on operation.

**Bit 6**

CCLR	Description
0	Normal operation (Initial value)
1	Clears the 5-bit DFG counter

**Bit 5—16-Bit Timer Counter Clock Source Selection Bit (CKSL):** Selects the clock source of the 16-bit timer counter.

**Bit 5**

CKSL	Description
0	$\phi_s/4$ (Initial value)
1	$\phi_s/8$

**Bits 4 to 0—FIFO1 Output Timing Setting Bits (DFCRA4 to DFCRA0):** Determine the starting point of the timing of FIFO1. The initial value is undetermined. Be sure to set a value after a reset or stand-by. It is valid only if bit 7 (FRT bit) of HSM2 is 0.

### (9) DFG Reference Register 2 (DFCRB)

Bit :	7	6	5	4	3	2	1	0
	—	—	—	DFCRB4	DFCRB3	DFCRB2	DFCRB1	DFCRB0
Initial value :	1	1	1	*	*	*	*	*
R/W :	—	—	—	W	W	W	W	W

Note: \* Undetermined

DFCRB is a register which determines the starting point of the timing of FIFO2.

DFCRB is an 8-bit write-only register. If a read is attempted, an undetermined value is read out. Bits 7 to 5 are reserved. No write is valid. If a read is attempted, 1 is read out. It is not initialized by a reset or stand-by, accordingly be sure to write data before use.

**Bits 4 to 0—FIFO2 Output Timing Setting Bits (DFCRB4 to DFCRB0):** Determine the starting of the FIFO2 output. The initial values are undetermined, accordingly be sure to write values in the bits after a reset or stand-by.

It is valid only if bit 7 (FRT bit) of HSM2 is 0.

### (10) FIFO Timer Capture Register (FTCTR)

Bit :	15	14	13	12	11	10	9	8	7	6	5	4	3	2	1	0
	FTCTR15	FTCTR14	FTCTR13	FTCTR12	FTCTR11	FTCTR10	FTCTR9	FTCTR8	FTCTR7	FTCTR6	FTCTR5	FTCTR4	FTCTR3	FTCTR2	FTCTR1	FTCTR0
Initial value :	0	0	0	0	0	0	0	0	0	0	0	0	0	0	0	0
R/W :	R	R	R	R	R	R	R	R	R	R	R	R	R	R	R	R

FTCTR is a register to display the count of the 16-bit timer counter.

FTCTR is a 16-bit read-only register. It stores the counter value if a VD signal was detected in PB mode. Only a word access is accepted. If a byte access is attempted, resulting operation is not assured. It is initialized to H'0000 by a reset or stand-by.

Note: Its address is shared with the FIFO timing pattern register 1 (FTPRA). Accordingly, if a write is attempted, the value is written in FTPRA.

**(11) DFG Reference Count Register (DFCTR)**

Bit :	7	6	5	4	3	2	1	0
	—	—	—	DFCTR4	DFCTR3	DFCTR2	DFCTR1	DFCTR0
Initial value :	1	1	1	0	0	0	0	0
R/W :	—	—	—	R	R	R	R	R

DFCTR is a register to count the DFG pulses.

DFCTR is an 8-bit read-only register. Bits 7 to 5 are reserved. If a read is attempted, 1 is read out. It is initialized to H'E0 by a reset or stand-by.

Note: Its address is shared with the DFG reference register 1 (DFCRA). Accordingly, if a write is attempted, the value is written in DFCRA.

**Bits 4 to 0—DFG Pulse Count Bits (DFCTR4 to DFCTR0):** Count the number of pulses of DFG.

### 28.4.6 Description of Operation

#### 1. 5-Bit DFG counter

The 5-bit DFG counter takes counts by the edges of DFG selected by the EDG bit of HSW mode register 2. The 5-bit DFG counter is cleared by the DPG's rise or when 1 was written in the CCLR bit of DFG reference register 1.

#### 2. 16-Bit Timer Counter

DFG reference mode or free-run mode can be selected for the 16-bit timer counter.

##### — DFG Reference Mode

DFG reference mode is based on the DFG signal. When the DFG reference registers 1 and 2 and the 5-bit DFG counter value match, the 16-bit timer counter is initialized, and that point becomes the starting of the FIFO output.

In DFG reference mode, the FGR2OFF bit of the HSW mode register 2 can be used to select between using only the DFG reference register 1 to set the starting of the FIFO output or using both DFG reference registers 1 and 2 to set the starting of the FIFO1 and FIFO2 outputs, respectively. When using only the DFG reference register 1 to set the starting, continuous values should be set as the timing patterns for FIFO1 and FIFO2.

##### — Free-Run Mode

Free-run mode is to operate together with the prescaler unit. An overflow of the 18-bit free-running counter in the prescaler unit initializes the 16-bit timer counter, and that point becomes the starting of the FIFO output.

#### 3. Matching Circuit

The matching circuit compares the timing pattern value of FIFO with the 16-bit timer counter value, and if they match, it generates a trigger signal to output the pattern data for the FIFO's next stage.

#### 4. FIFO

FIFO generates the head-switching signal used in the VCR and the pattern data necessary for servo control. Data is set in FIFO by the FIFO timing pattern registers 1 and 2 and the FIFO output pattern registers 1 and 2.

FIFO has two modes, i.e. single mode and loop mode. In either mode, output of 20 stages of FIFO1 + FIFO2 or output of only 10 stages of FIFO1 can be selected.

##### — Single Mode

In single mode, the output pattern data is output each time the timing data matches. The data, once output, is lost, and the internal pointer is decremented by 1. When the last data was output, it stops operation until data is written again. When it is used in the 20-stage output mode, writing in FIFO1 and FIFO2 has to be controlled by software.



### — Loop Mode

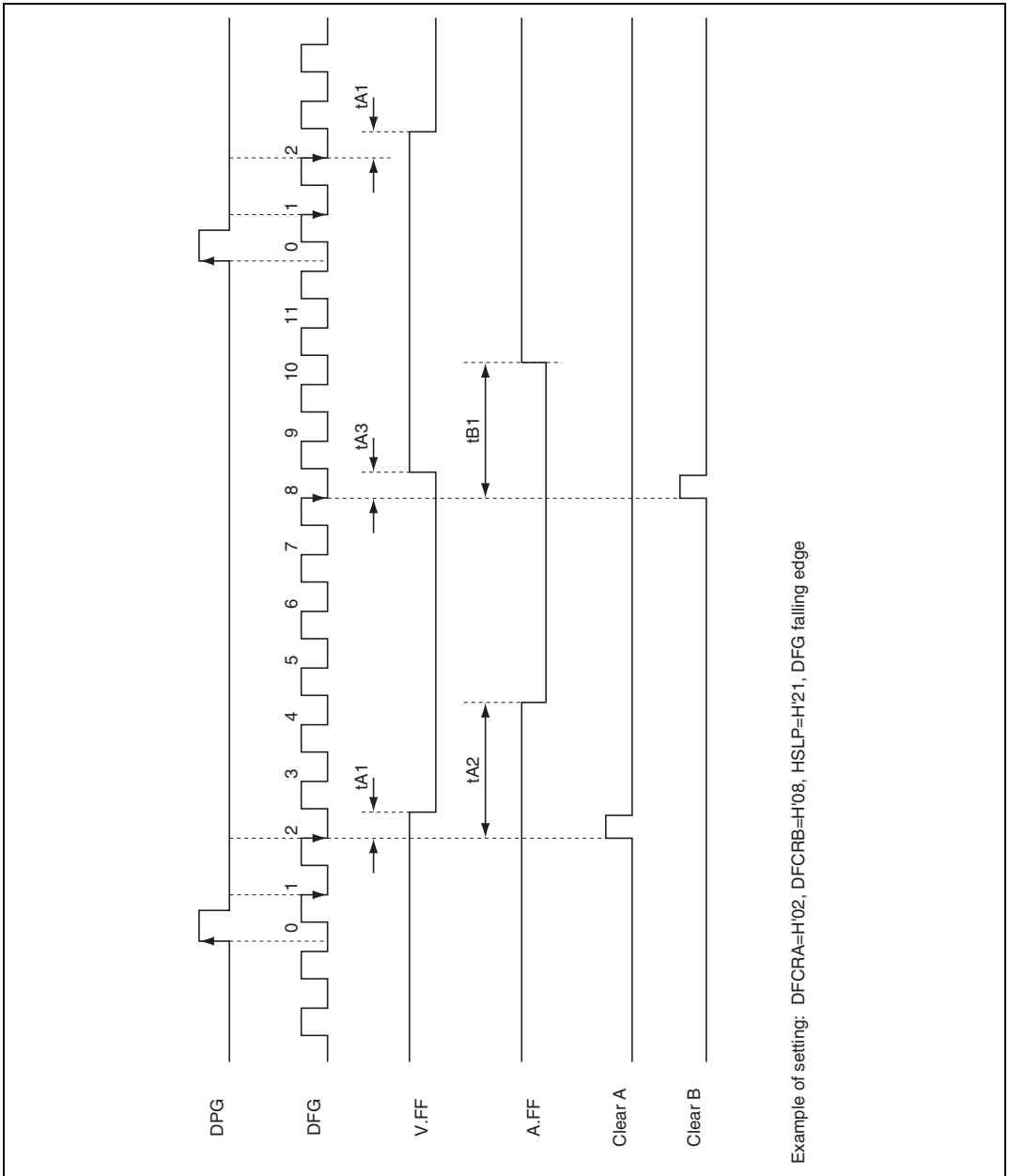
In loop mode, the output pattern cycles repeatedly from stage 0 through the final stage selected in the HSW loop number setting register. As in single mode, the output pattern data is output each time the timing data matches. In loop mode, the FIFO data is retained.

When loop mode is active, data can be rewritten for each FIFO group.

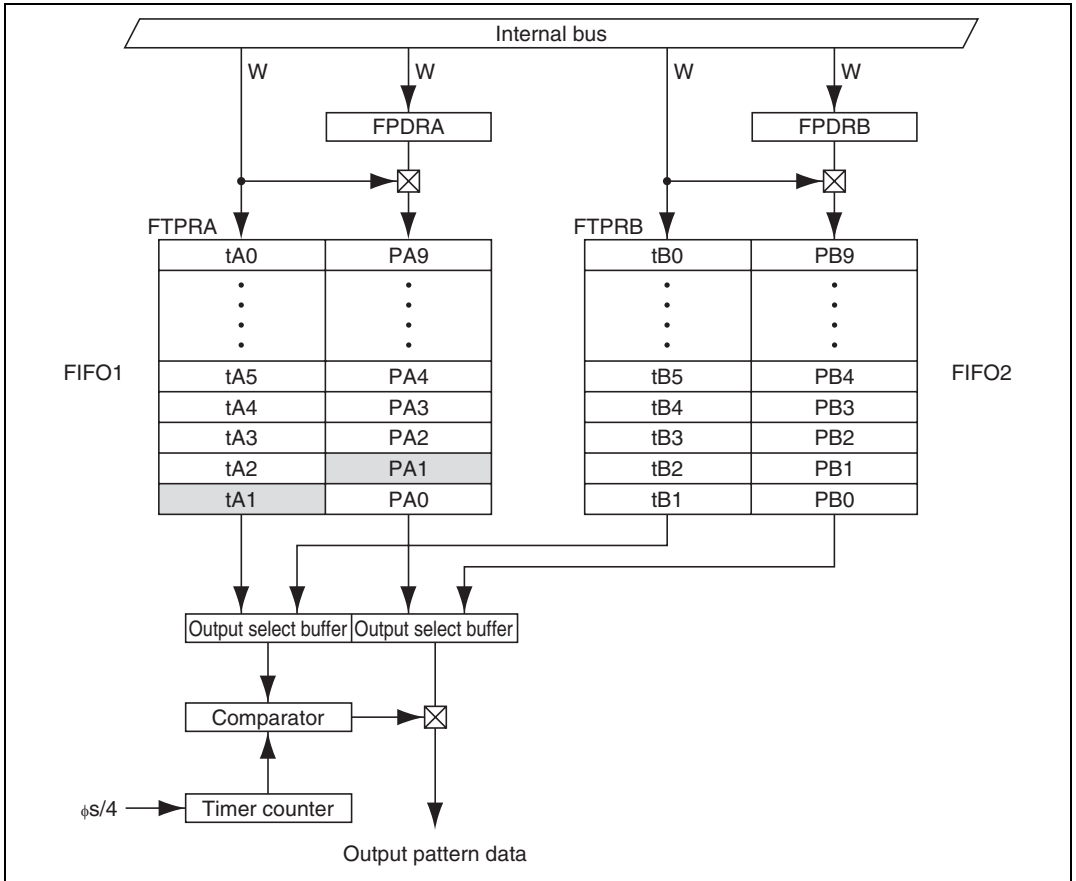
After confirming with the OFG bit of the HSW mode register 2 which FIFO group is outputting, clear the FIFO group which is not outputting and write data for the entire FIFO group. Writing has to be completed before the rewritten FIFO group starts operation.

Partial rewriting in the FIFO is not possible, because the write pointer is outside the loop stages.

Figures 28.23 and 28.24 show examples of the timing waveform and its operation of the HSW timing generator.



**Figure 28.23 Example of Timing Waveform of HSW (when DFG Is 12 Shots)**



**Figure 28.24 Example of Operation of the HSW Timing Generator**

- (1) Example of operation in single mode (20 stages of FIFO used)
  - (a) Set to single mode ( $LOP = 0$ )
  - (b) Write the output pattern data (PA0) to FPDRA.
  - (c) Write the output timing ( $t_{A1}$ ) to FTPRA.  $t_{A1}$  is written in FIFO1 together with PA0. This initializes the output pattern data to PA0.
  - (d) Repeat the steps in the same way, until PA1, PA2, etc., are set.
  - (e) Write the output pattern data (PB0) to FPDRB.
  - (f) Write the output timing ( $t_{B1}$ ) to FTPRB.  $t_{B1}$  is written in FIFO2 together with PB0. This initializes the output pattern data to PB0.
  - (g) Repeat these steps in the same way, until PB1, PB2, etc., are set.

From (c), the pattern data of PA0 is output.

If  $t_{A1}$  matches with the timer counter, the pattern data of PA1 is output.

If  $t_{A2}$  matches with the timer counter, the pattern data of PA2 is output.

.  
. .  
.

After this sequence is repeated and all the pattern data set in FIFO1 is output, the pattern data of FIFO2 is output. After the pattern data is output, the pointer is decremented by 1. Care is required, however, because matching of  $t_{A0}$  is not detected until data is written in FIFO2. Matching of  $t_{B0}$  also is not detected until data is written in FIFO1 again.

(2) Example of operation in loop mode

- (a) Set the number of loop stages in the HSLP register (e.g. HSLP = H'44)
- (b) Write the output pattern data (PA0) to FPDRA.
- (c) Write the output timing ( $t_{A1}$ ) to FTPRA.  $t_{A1}$  is written in FIFO1 together with PA0. This initializes the output pattern data to PA0.
- (d) Repeat the steps in the same way, until PA1, PA2, etc., are set.
- (e) Write the output pattern data (PB0) to FPDRB.
- (f) Write the output timing ( $t_{B1}$ ) to FTPRB.  $t_{B1}$  is written in FIFO2 together with PB0. This initializes the output pattern data to PB0.
- (g) Repeat the steps in the same way, until PB1, PB2, etc., are set.

From (c), the pattern data PA0 is output.

If  $t_{A1}$  matches the timer counter, the pattern data PA1 is output.

If  $t_{A2}$  matches the timer counter, the pattern data PA2 is output.

.

.

.

If  $t_{A4}$  matches the timer counter, the pattern data PA4 is output.

If  $t_{A5}$  matches the timer counter, the pattern data PB0 is output.

If  $t_{B1}$  matches the timer counter, the pattern data PB1 is output.

.

.

.

If  $t_{B4}$  matches the timer counter, the pattern data PB4 is output.

If  $t_{B5}$  matches the timer counter, the pattern data PA0 is output.

.

.

.

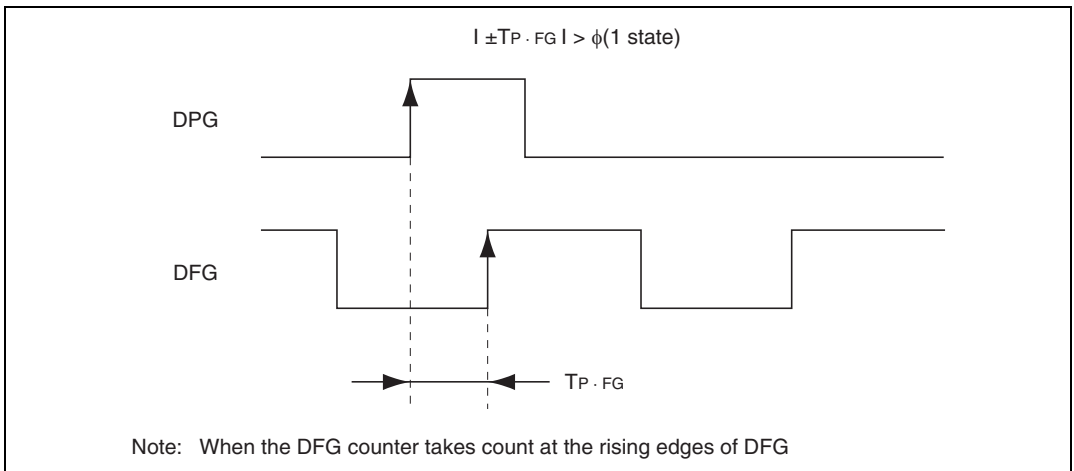
### 28.4.7 Interrupt

The HSW timing generator generates an interrupt under the following conditions.

- (1) IRRHSW1 occurred when pattern data was written (OVWA, OVWB = 1) and FIFO was full (FULL).
  - (2) IRRHSW1 occurred when matching was detected and the STRIG bit of FIFO was 1.
  - (3) IRRHSW1 occurred when the values of the 16-bit timer counter and 16-bit timing pattern register matched.
  - (4) IRRHSW2 occurred when the 16-bit timer counter was cleared.
  - (5) IRRHSW2 occurred when a VD signal (capture signal of the timer capture register) was received in PB mode.
- (2) and (3), as well as (4) and (5), are switched over by ISEL1 and ISEL2.

### 28.4.8 Cautions

- (1) When both the 5-bit DFG counter and 16-bit timer counter are operating, the latter is not cleared if input of DPG and DFG signals is stopped. This leads to free-running of the 16-bit timer counter, and periodical detection of matching by the 16-bit timer counter. In such a case, the period of the output from the HSW timing generator is independent from DPG or DFG.
- (2) Specify the mode setting bit (LOP) of the HSW mode register 2 (HSM2) immediately before writing the FIFO data.
- (3) Input the rising edge of DPG and DFG count edge at different timings. If the same timing was input, counting up of DFG and clearing of the 5-bit DFG counter occurs simultaneously. In this case, the latter will take precedence. This leads to the 5-bit DFG counter's lag by 1. Figure 28.25 shows the input timing of DPG and DFG.
- (4) If stop of the drum system is required when FIFO output is being used in the 20-stage output mode, rewrite the SOFG bit of HSM2 register 0 → 1 → 0 by software, and initialize the FIFO output stage to the FIFO1 side without fail. Also clear and rewrite the data of FIFO1 and FIFO2.



**Figure 28.25 Input Timing of DPG and DFG**

## 28.5 Four-Head High-Speed Switching Circuit for Special Playback

### 28.5.1 Overview

This four-head high-speed switching circuit generates a color rotary signal (C.Rotary) and head-amplifier switching signal (H.Amp SW) for use in four-head special playback.

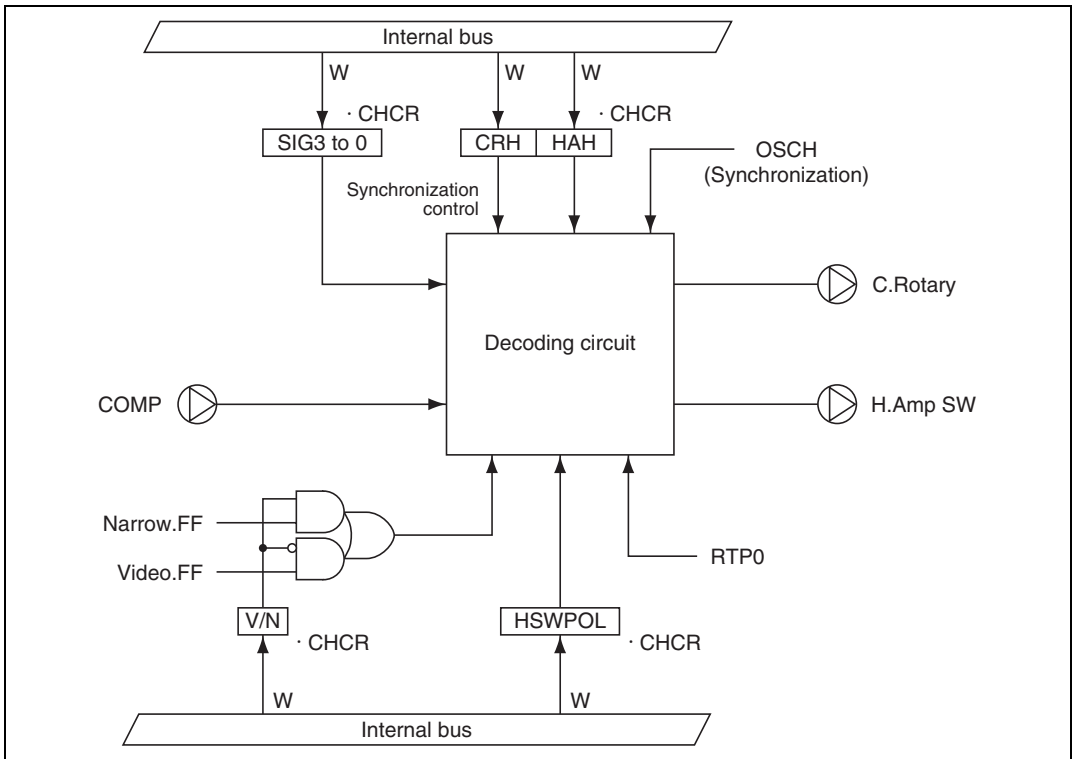
A pre-amplifier output comparison result signal is input from the COMP pin. The signal output at the C.Rotary pin is a Chroma signal processing control signal. The signal output at the H.Amp SW pin is a pre-amplifier output select signal. To reduce the width of noise bars, the C.Rotary and H.Amp SW signals are synchronized to the horizontal sync signal (OSCH). OSCH is made by adding supplemented H, which has been separated from the Csync signal in the sync signal detector circuit. For more details of OSCH, see section 28.15, Sync Signal Detector.

If the C.Rotary, H.Amp SW or COMP pin does not require this circuit to configure a VCR system, it can be used as an I/O port.

### 28.5.2 Block Diagram

Figure 28.26 shows the block diagram of this circuit.





**Figure 28.26 Four-Head High-Speed Switching Circuit for Special Playback**

### 28.5.3 Pin Configuration

Table 28.7 summarizes the pin configuration of the high-speed switching circuit used in four-head special playback. They can also be used as I/O ports when not in use. See section 28.2, Servo Port.

**Table 28.7 Pin Configuration**

Name	Abbrev.	I/O	Function
Compare input pin	COMP	Input	Input of pre-amplifier output result signal
Color rotary signal output pin	C.Rotary	Output	Output of chroma processing control signal
Head-amplifier switching pin	H.Amp SW	Output	Output of pre-amplifier output select signal

## 28.5.4 Register Description

### (1) Register Configuration

Table 28.8 shows the register configuration of the high-speed switching circuit used in four-head special playback.

**Table 28.8 Register Configuration**

Name	Abbrev.	R/W	Size	Initial Value	Address
Special playback control register	CHCR	W	Byte	H'00	H'FD06E

### (2) Special Playback Control Register (CHCR)

Bit :	7	6	5	4	3	2	1	0
	V/N	HSWPOL	CRH	HAH	SIG3	SIG2	SIG1	SIG0
Initial value :	0	0	0	0	0	0	0	0
R/W :	W	W	W	W	W	W	W	W

The special playback control register (CHCR) is an 8-bit write-only register. It cannot be read. If a read is attempted, an undetermined value is read out. It is initialized to H'00 by a reset, stand-by or module stop.

**Bit 7—HSW Signal Selection Bit (V/N):** Selects the HSW signal to be used at special playback.

#### Bit 7

V/N	Description
0	Video FF signal output (Initial value)
1	Narrow FF signal output

**Bit 6—COMP Polarity Selection Bit (HSWPOL):** Selects the polarity of the COMP signal.

#### Bit 6

HSWPOL	Description
0	Positive (Initial value)
1	Negative

**Bit 5—C.Rotary Synchronization Control Bit (CRH):** Synchronizes the C.Rotary signal with the OSCH signal.

**Bit 5**

CRH	Description
0	Synchronous (Initial value)
1	Asynchronous

**Bit 4—H.Amp SW Synchronization Control Bit (HAH):** Synchronizes the H.Amp SW signal with the OSCH signal.

**Bit 4**

HAH	Description
0	Synchronous (Initial value)
1	Asynchronous

**Bits 3 to 0—Signal Control Bits (SIG3 to SIG0):** These bits, combined with the state of the COMP input pin, control the outputs at the C.Rotary and H.Amp SW pins.

Bit 3	Bit 2	Bit 1	Bit 0	Output Pins		
SIG3	SIG2	SIG1	SIG0	C.Rotary	H.Amp SW	
0	0	*	*	L	L (Initial value)	
			0	HSW	L	
	1	0	0	0	HSW	H
				1	L	HSW
				0	H	HSW
				1	HSW EX-OR COMP	COMP
1	1	0	0	HSW EX-NOR COMP	COMP	
			0	HSW E-OR RTP0	RTP0	
			1	HSW EX-NOR RTP0	RTP0	
			1	HSW EX-NOR RTP0	RTP0	

Legend: \* Don't care.

## 28.6 Drum Speed Error Detector

### 28.6.1 Overview

Drum speed error control operates so as to hold the drum at a constant revolution speed by measuring the period of the DFG signal. A digital counter detects the speed deviation from a preset value. The speed error data is processed and added to phase error data in a digital filter. This filter controls a pulse-width modulated (PWM) output, which controls the revolution speed and phase of the drum.

The DFG input signal is reshaped into a square wave by a reshaping circuit, and sent to the speed error detector as the DFG signal.

The speed error detector uses the system clock to measure the period of the DFG signal, and detects the deviation from a preset data value. The preset data is the value that would result from measuring the DFG signal period with the clock signal if the drum motor was running at the correct speed.

The error detector operates by latching a counter value when it detects an edge of the DFG signal. The latched count provides 16 bits of speed error data for the digital filter to operate on. The digital filter processes and adds the speed error data to phase error data from the drum phase control system, then sends the result to the pulse-width modulator as drum error data.

### 28.6.2 Block Diagram

Figure 28.27 shows a block diagram of the drum speed error detector.



### 28.6.3 Register Configuration

Table 28.9 shows the register configuration of the drum speed error detector.

**Table 28.9 Register Configuration**

<b>Name</b>	<b>Abbrev.</b>	<b>R/W</b>	<b>Size</b>	<b>Initial Value</b>	<b>Address</b>
Specified DFG speed preset data register	DFPR	W	Word	H'0000	H'FD030
DFG speed error data register	DFER	R/W	Word	H'0000	H'FD032
DFG lock UPPER data register	DFRU DR	W	Word	H'7FFF	H'FD034
DFG lock LOWER data register	DFRLDR	W	Word	H'8000	H'FD036
Drum speed error detection control register	DFVCR	R/W	Byte	H'00	H'FD038

## 28.6.4 Register Descriptions

### (1) Specified DFG Speed Preset Data Register (DFPR)

Bit :	15	14	13	12	11	10	9	8	7	6	5	4	3	2	1	0
Initial value :	0	0	0	0	0	0	0	0	0	0	0	0	0	0	0	0
R/W :	W	W	W	W	W	W	W	W	W	W	W	W	W	W	W	W

The specified DFG speed preset data is set in DFPR. When the data is written, a 16-bit preset data is sent to the preset circuit. The preset data is referenced to H'8000\*, and can be calculated from the following equation.

$$\text{Specified DFG speed preset data} = \text{H}'8000 - \left( \frac{\phi s/n}{\text{DFG frequency}} - 2 \right)$$

$\phi$  s: Servo clock frequency ( $f_{osc}/2$ ) in Hz

DFG frequency: In Hz

The constant 2 is the presetting interval (see figure 28.28).

$\phi$  s/n Clock source of selected counter

DFPR is a 16-bit write-only register, and is accessible by word access only. Byte access gives unassured results. Reads are disabled. DFPR is initialized to H'0000 by a reset, and in standby mode and module stop mode.

Note: \* The preset data value is calculated so that the counter will reach H'8000 when the error is zero. When the counter value is latched as error data in the DFG speed error data register (DFER), however, it is converted to a value referenced to H'0000.

**(2) DFG Speed Error Data Register (DFER)**

Bit :	15	14	13	12	11	10	9	8	7	6	5	4	3	2	1	0

Initial value : 0 0 0 0 0 0 0 0 0 0 0 0 0 0 0 0

R/W : R\*/W R\*/W R\*/W R\*/W R\*/W R\*/W R\*/W R\*/W R\*/W R\*/W R\*/W R\*/W R\*/W R\*/W R\*/W R\*/W

Note: \* Note that only detected error data can be read.

DFER is a register that stores 16-bit DFG speed error data. When the drum motor speed is correct, the data latched in DFER is H'0000. Negative data will be latched if the speed is too fast, and positive data if the speed is too slow. The DFER value is sent to the digital filter either automatically or by software.

DFER is a 16-bit readable/writable register. DFER is accessible by word access only. Byte access gives unassured results. DFER is initialized to H'0000 by a reset, and in standby mode and module stop mode.

Refer to the note in 28.6.4 (1), Specified DFG Speed Preset Data Register (DFPR).

**(3) DFG Lock UPPER Data Register (DFRUDR)**

Bit :	15	14	13	12	11	10	9	8	7	6	5	4	3	2	1	0

Initial value : 0 1 1 1 1 1 1 1 1 1 1 1 1 1 1 1

R/W : W W W W W W W W W W W W W W W W

DFRUDR is a register used to set the lock range on the UPPER side when drum speed lock is detected, and to set the limit value on the UPPER side when the limiter function is in use. Set a signed data to DFRUDR (bit 15 is a sign-setting bit).

When lock is being detected, if the drum speed is detected within the lock range, the lock counter which has been set by DFRCS 1 and 0 bits of the DFVCR register counts down. If the set value of DFRCS 1 and 0 matches the number of times of occurrence of locking, the computation of the digital filter in the drum phase system can be controlled automatically. Also, if the DFG speed error data is beyond the DFRUDR value while the limiter function is in use, the DFRUDR value can be used as the data for computation by the digital filter.

DFRUDR is a 16-bit write-only register. Only a word access is valid. If a byte access is attempted, operation is not assured. No read is valid. If a read is attempted, an undetermined value is read out. It is initialized to H'7FFF by a reset, stand-by or module-stop.



**(4) DFG Lock LOWER Data Register (DFRLDR)**

Bit :	15	14	13	12	11	10	9	8	7	6	5	4	3	2	1	0
Initial value :	1	0	0	0	0	0	0	0	0	0	0	0	0	0	0	0
R/W :	W	W	W	W	W	W	W	W	W	W	W	W	W	W	W	W

DFRLDR is a register used to set the lock range on the LOWER side when drum speed lock is detected, and to set the limit value on LOWER side when the limiter function is in use. Set a signed data to DFRLDR (bit 15 is a sign-setting bit).

When lock is being detected, if the drum speed is detected within the lock range, the lock counter which has been set by the DFRCS1 and DFRCS0 bits of the DFVCR register counts down. If the set value of DFRCS1 and DFRCS0 matches the number of times of occurrence of locking, the computation of the digital filter in the drum phase system can be controlled automatically. Also, if the DFG speed error data is under the DFRLDR value when the limiter function is in use, the DFRLDR value can be used as the data for computation by the digital filter.

DFRLDR is a 16-bit write-only register. Only a word access is valid. If a byte access is attempted, operation is not assured. No read is valid. If a read is attempted, an undetermined value is read out. It is initialized to H'8000 by a reset, stand-by or module-stop.

**(5) Drum Speed Error Detection Control Register (DFVCR)**

Bit :	7	6	5	4	3	2	1	0
	DFCS1	DFCS0	DFOVF	DFRFON	DF-R/UNR	DPCNT	DFRCS1	DFRCS0
Initial value :	0	0	0	0	0	0	0	0
R/W :	R/W	R/W	R/(W)*1	R/W	R	R/W	(R)*2/W	(R)*2/W

- Notes: 1. Only 0 can be written.  
2. If read-accessed, the counter value is read out.

DFVCR controls the operation of drum speed error detection.

DFVCR is an 8-bit readable/writable register. Bit 3 accepts only read, and bit 5 accepts only read and 0 write. It is initialized to H'00 by a reset, stand-by or module-stop.

**Bits 7 and 6—Clock Source Selection Bits (DFCS1, DFCS0):** DFCS1 and DFCS0 select the clock to be supplied to the counter. ( $\phi_s = f_{osc}/2$ )

Bit 7		Bit 6		Description
DFCS1	DFCS0	DFCS1	DFCS0	
0	0	0	0	$\phi_s$ (Initial value)
	0	0	1	$\phi_s/2$
1	0	0	0	$\phi_s/4$
	0	0	1	$\phi_s/8$

**Bit 5—Counter Overflow Flag (DFOVF):** The DFOVF flag indicates the overflow of the 16-bit counter. It is cleared by writing 0. Write 0 after reading 1. Also, setting has the highest priority in this flag. If a flag set and 0 write occurs simultaneously, the latter is nullified.

Bit 5		Description
DFOVF	DFOVF	
0	0	Normal state (Initial value)
1	1	Indicates that overflow has occurred in the counter

**Bit 4—Error Data Limit Function Selection Bit (DFRFON):** Makes the error data limit function valid. (Limit values are the values set in the lock range data register (DFRUDR, DFRLDR)).

Bit 4		Description
DFRFON	DFRFON	
0	0	Limit function off (Initial value)
1	1	Limit function on

**Bit 3—Drum Lock Flag (DF-R/UNR):** Sets a flag if an underflow occurred in the drum lock counter.

Bit 3		Description
DF-R/UNR	DF-R/UNR	
0	0	Indicates that the drum speed system is not locked (Initial value)
1	1	Indicates that the drum speed system is locked

**Bit 2—Drum Phase System Filter Computation Automatic Start Bit (DPCNT):** Sets on the filter computation of the phase system if an underflow occurred in the drum lock counter.

**Bit 2**

<b>DPCNT</b>	<b>Description</b>
0	Does not perform the filter computation by detection of the drum lock (Initial value)
1	Sets on the filter computation of the phase system when drum lock is detected

**Bits 1 and 0—Drum Lock Counter Setting Bits (DFRCS1, DFRCS0):** Set the number of times where drum lock has been determined (DFG has been detected in the range set by the lock range data register). It sets the drum lock flag if it detected the set number of times of occurrence of drum lock. If an NCDFG signal is detected outside the lock range after data is written in DFRCS1 and 0, data is stored in the lock counter.

Note: If DFRCS1 or DFRCS0 is read-accessed, the counter value is read out. If bit 3 (drum lock flag) is 1 and the drum lock counter's value is 3, it indicates that the drum speed system is locked. The drum lock counter stops until lock is released after underflow.

<b>Bit 1</b>	<b>Bit 0</b>	<b>Description</b>
0	0	Underflow after lock was detected once (Initial value)
	1	Underflow after lock was detected twice
1	0	Underflow after lock was detected three times
	1	Underflow after lock was detected four times

### 28.6.5 Description of Operation

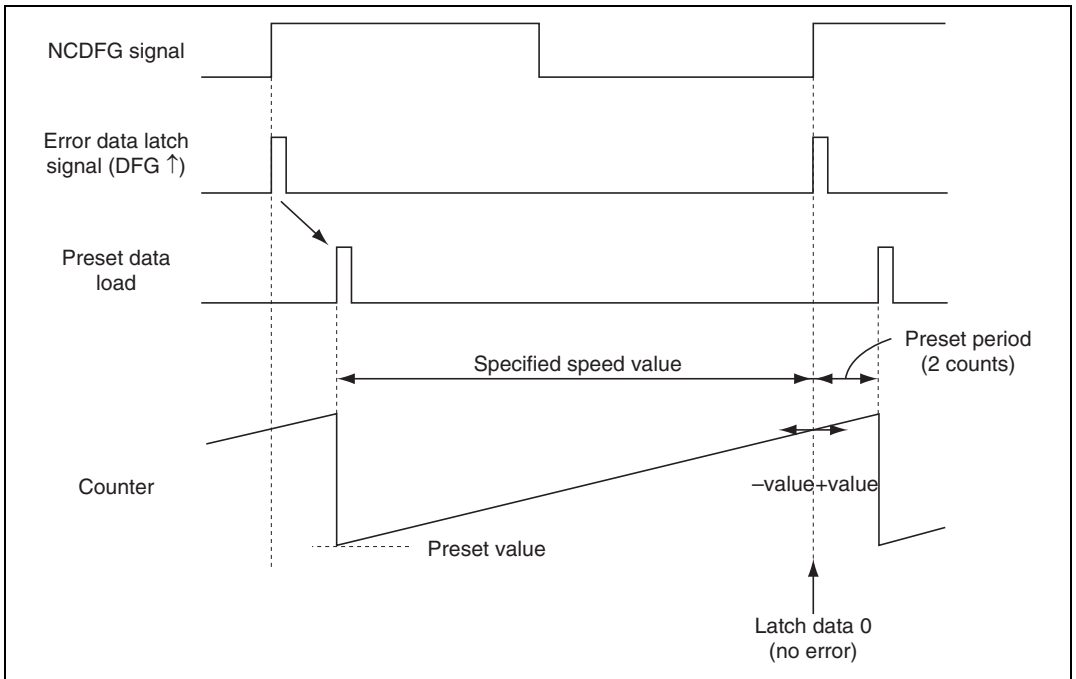
The drum speed error detector detects the speed error based on the reference value set in the DFG specified speed preset register (DFPR). The reference value set in DFPR is preset in the counter by the NCDFG signal, and counts down by the selected clock. The timing of the counter presetting and the error data latching can be selected between the rising or falling edge of the NCDFG signal. See section 28.14.4, DFG Noise Removal Circuit. The error data detected is sent to the digital filter circuit. The error data is signed binaries. It takes a positive number (+) if the speed is slower than the specified speed, a negative number (-) if the speed is faster, or 0 if it correct (revolving at the specified speed). Figure 28.28 shows an example of operation to detect the drum speed.

**Setting the Error Data Limit:** A limit can be set to the error data sent to the digital filter circuit using the DFG lock data register (DFRUDR, DFRLDR). Set the upper limit of the error data in DFRUDR and the lower limit in DFRLDR, and write 1 in the DFRFON bit. If the error data is beyond the limit range, the DFRLDR value is sent if a negative number is latched, or the DFRUDR value is sent if a positive one is latched, as a limit value. Be sure to turn off the limit setting (DFRFON = 0) when you set the limit value. If the limit was set with the limit setting on (DFRFON = 1), result of computation is not assured.

**Lock Detection:** If an error data was detected within the lock range set in the lock data register, the drum lock flag (DF-R/UNR) is set by the number of the times of occurrence of locking set by the DFRCS1 and DFRCS0 bits, and an interrupt is requested (IRRDRM2) at the same time. The number of the occurrence of locking (once to 4 times) can be specified when setting the flag. Use the DFRCS1 and DFRCS0 bits for this purpose. Also, if bit 5 (DPHA bit) of the drum system digital filter control register (DFIC) is 0 (phased system digital filter computation off) and the DPCNT bit is 1, turning on/off of the phase system digital filter computation can be controlled automatically by the status of lock detection.

**Drum System sSpeed Error Detection Counter:** The drum system speed error detection counter stops the counter and sets the overflow flag (DFOVF) when the overflow occurred. At the same time, it generates an interrupt request (IRRDRM1). Clear DFOVF by writing 0 after reading 1. If setting the flag and writing 0 take place simultaneously, the latter is nullified.

**Interrupt Request:** IRRDRM1 is generated by the NCDFG signal latch and the overflow of the error detection counter. IRRDRM2 is generated by detection of lock (after the detection of the number of times of setting).



**Figure 28.28 Example of the Operation of the Drum Speed Error Detection (Selection of the Rising Edge of DFG)**

### 28.6.6 $f_H$ Correction in Trick Play Mode

In trick play mode, the tape speed changes relative to the video head. This change alters the horizontal sync signal ( $f_H$ ), causing skew. To correct the skew, the drum motor speed must be shifted to a different speed in each trick play mode, so as to obtain the normal horizontal sync frequency. To shift the drum motor speed, software should modify the value written in the DFG preset data register in the speed error detector.

This  $f_H$  correction can be expressed in terms of the basic frequency  $f_F$  of the drum as follows.

$$f_F = \frac{N_0}{N_0 + \alpha_H (1 - n)} \times f_{F0}$$

Legend:

$n$ : Speed multiplier (FWD = positive, REV = negative)

$\alpha_H$ : H alignment (1.5 H in standard mode, 0.75 H in 2× mode, and 0.5 H in 3× mode for VHS and  $\beta$  systems; 1 H for an 8-mm VCR)

$N_0$ : Standard H numbers within field

$f_{F0}$ : Field frequency

NTSC:  $N_0 = 262.5$ ,  $f_{F0} = 59.94$

PAL:  $N_0 = 312.5$ ,  $f_{F0} = 50.00$

## 28.7 Drum Phase Error Detector

### 28.7.1 Overview

Drum phase control must start operating after the drum motor is brought to the correct revolution speed by the speed control system. Drum phase control works as follows in record and playback.

Record: Phase is controlled so that the vertical blanking intervals of the recorded video signal will line up along the bottom edge of the tape.

Playback: Phase is controlled so as to trace the recorded tracks accurately.

A digital counter detects the phase deviation from a preset value. The phase error data is processed and added to speed error data in a digital filter. This filter controls a pulse-width modulated (PWM) output, which controls the rotational phase and speed of the drum.

The DPG signal from the drum motor is reshaped into a rectangular pulse waveform by a reshaping circuit, and sent to the phase error detector.

The phase error detector compares the phase of the DPG pulse (tackle pulse), which contains video head phase information, with a reference signal. In the actual circuit, the comparison is carried out by comparing the head-switching (HSW) signal, which is delayed by a counter that is reset by DPG, with a reference signal value. The reference signal is the REF30 signal, which differs between record and playback as follows.

Record: Vsync signal extracted from the video signal to be recorded (frame rate signal, actually 1/2 Vsync)

Playback: 30 Hz or 25 Hz signal divided from the system clock

### 28.7.2 Block Diagram

Figure 28.29 shows a block diagram of the drum phase error detector.

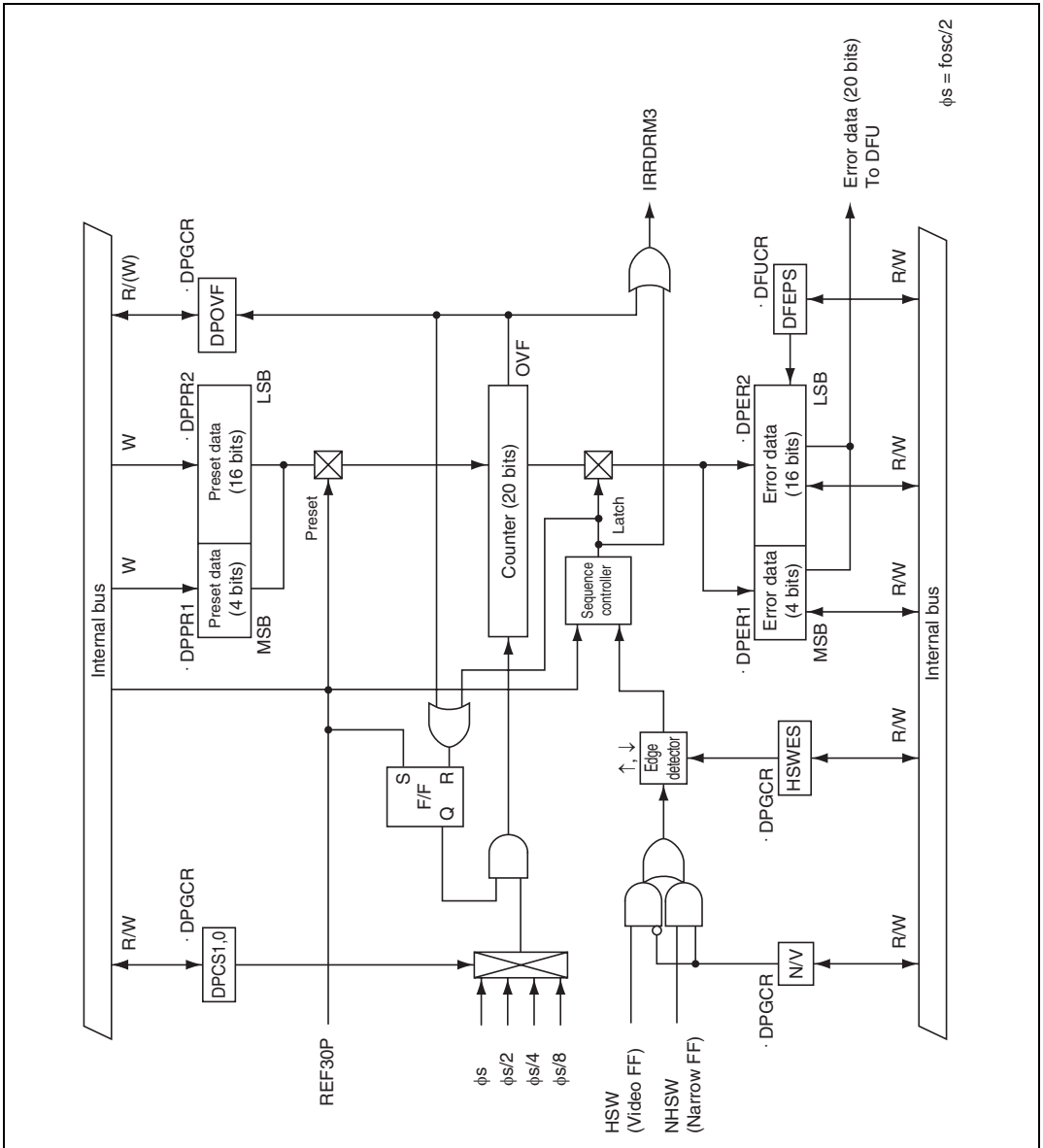


Figure 28.29 Block Diagram of Drum Phase Error Detector



### 28.7.3 Register Configuration

Table 28.10 shows the register configuration of the drum phase error detector.

**Table 28.10 Register Configuration**

<b>Name</b>	<b>Abbrev.</b>	<b>R/W</b>	<b>Size</b>	<b>Initial Value</b>	<b>Address</b>
Drum phase preset data register 1	DPPR1	W	Byte	H'F0	H'FD03C
Drum phase preset data register 2	DPPR2	W	Word	H'0000	H'FD03A
Drum phase error data register 1	DPER1	R/W	Byte	H'F0	H'FD03D
Drum phase error data register 2	DPER2	R/W	Word	H'0000	H'FD03E
Drum phase error detection control register	DPGCR	R/W	Byte	H'07	H'FD039

## 28.7.4 Register Descriptions

### (1) Drum Phase Preset Data Registers (DPPR1, DPPR2)

#### DPPR1

Bit :	7	6	5	4	3	2	1	0
	—	—	—	—				
Initial value :	1	1	1	1	0	0	0	0
R/W :	—	—	—	—	W	W	W	W

#### DPPR2

Bit :	15	14	13	12	11	10	9	8	7	6	5	4	3	2	1	0
Initial value :	0	0	0	0	0	0	0	0	0	0	0	0	0	0	0	0
R/W :	W	W	W	W	W	W	W	W	W	W	W	W	W	W	W	W

The 20-bit preset data that defines the specified drum phase is set in DPPR1 and DPPR2. The 20 bits are weighted as follows. Bit 3 of DPPR1 is the MSB, and bit 0 of DPPR2 is the LSB. When data is written to DPPR2, the 20-bit preset data, including DPPR1, is loaded into the preset circuit. Write to DPPR1 first, and DPPR2 next. The preset data is referenced to H'80000\*, and can be calculated from the following equation.

$$\begin{aligned} \text{Target phase difference} &= (\text{reference signal frequency}/2) - 6.5 \text{ H} \\ \text{Drum phase preset data} &= \text{H}'80000 - (\phi_s/n \times \text{target phase difference}) \end{aligned}$$

$\phi_s$ : Servo clock frequency in Hz ( $f_{osc}/2$ )

$\phi_s/n$ : Clock source of selected counter

DPPR2 is accessible by word access only. Byte access gives unassured results. Reads are disabled. DPPR1 and DPPR2 are initialized to H'F0 and H'0000 by a reset, and in standby mode.

Note: \* The preset data value is calculated so that the counter will reach H'80000 when the error value is zero. When the counter value is latched as error data in the drum phase error data registers (DPER1 and DPER2), however, it is converted to a value referenced to H'00000.

**(2) Drum Phase Error Data Registers (DPER1, DPER2)****DPER1**

Bit :	7	6	5	4	3	2	1	0
	—	—	—	—				
Initial value :	1	1	1	1	0	0	0	0
R/W :	—	—	—	—	R*/W	R*/W	R*/W	R*/W

**DPER2**

Bit :	15	14	13	12	11	10	9	8	7	6	5	4	3	2	1	0
Initial value :	0	0	0	0	0	0	0	0	0	0	0	0	0	0	0	0
R/W :	R*/W	R*/W	R*/W	R*/W	R*/W	R*/W	R*/W	R*/W	R*/W	R*/W	R*/W	R*/W	R*/W	R*/W	R*/W	R*/W

Note: \* Note that only detected error data can be read.

DPER1 and DPER2 consist of a 20-bit DPG phase error data register. The 20 bits are weighted as follows. Bit 3 of DPER1 is the MSB, and bit 0 of DPER2 is the LSB. When the rotational phase is correct, the data H'00000 is latched. Negative data will be latched if the drum leads the correct phase, and positive data if it lags. Values in DPER1 and DPER 2 are transferred to the digital filter circuit.

DPER1 and DPER2 are 20-bit readable/writable registers. When writing data to DPER1 and DPER2, write to DPER1 first, and then write to DPER2. DPER2 is accessible by word access only. Byte access gives unassured results. DPER1 and DPER2 are initialized to H'F0 and H'0000 by a reset, and in standby mode.

See the note on the drum phase preset data registers (DPPR1 and DPPR2) in section 28.7.4 (1), Drum Phase Present Data Register (DPPR1, DPPR2).

**(3) Drum Phase Error Detection Control Register (DPGCR)**

Bit :	7	6	5	4	3	2	1	0
	DPCS1	DPCS0	DPOVF	N/V	HSWES	—	—	—
Initial value :	0	0	0	0	0	1	1	1
R/W :	R/W	R/W	R/(W)*	R/W	R/W	—	—	—

Note: \* Only 0 can be written.

DPGCR controls the operation of drum phase error detection.

DPGCR is an 8-bit readable/writable register. Bits 2 to 0 are reserved, bit 5 accepts only read and 0 write.

It is initialized to H'07 by a reset or stand-by.

**Bits 7 and 6—Clock Source Selection Bits (DPCS1, DPCS0):** Select the clock supplied to the counter. ( $\phi_s = f_{osc}/2$ )

Bit 7		Bit 6		Description
DPCS1	DPCS0	DPCS1	DPCS0	
0	0	0	0	$\phi_s$ (Initial value)
	0	1	1	$\phi_s/2$
1	0	0	0	$\phi_s/3$
	1	1	1	$\phi_s/4$

**Bit 5—Counter Overflow Flag (DPOVF):** The DPOVF flag indicates the overflow of the 20-bit counter. It is cleared by writing 0. Write 0 after reading 1. Also, setting has the highest priority in this flag. If a flag set and 0 write occurs simultaneously, the latter is nullified.

Bit 5		Description
DPOVF	DPOVF	
0	0	Normal state (Initial value)
1	1	Indicates that an overflow has occurred in the counter

**Bit 4—Error Data Latch Signal Selection Bit (N/V):** Selects the latch signal of error data.

Bit 4		Description
N/V	N/V	
0	0	HSW (VideoFF) signal (Initial value)
1	1	NHSW (NarrowFF) signal

**Bit 3—Edge Selection Bit (HSWES):** Selects the edge of the error data latch signal (HSW or NHSW).

Bit 3		Description
HSWES	HSWES	
0	0	Latches at the rising edge (Initial value)
1	1	Latches at the falling edge

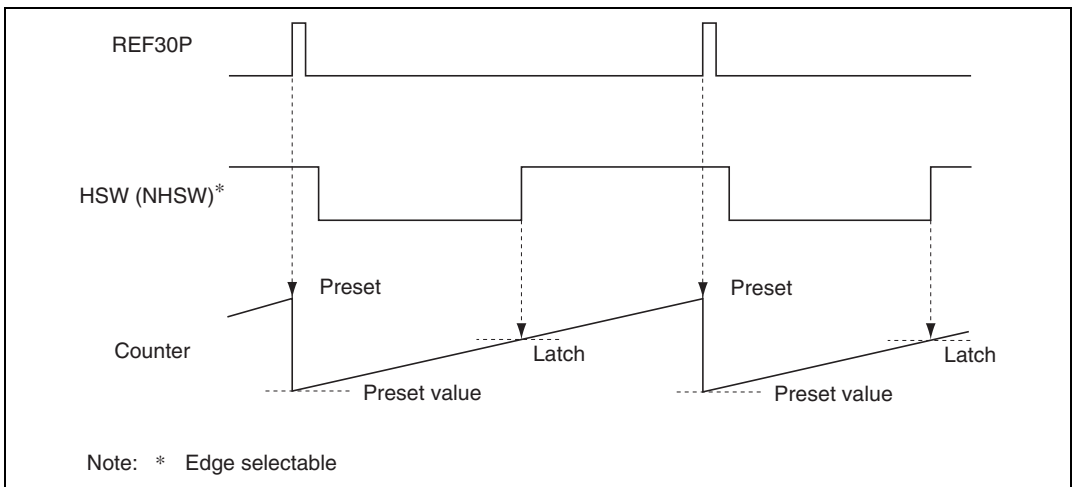
**Bits 2 to 0—Reserved:** No read or write is valid.

### 28.7.5 Description of Operation

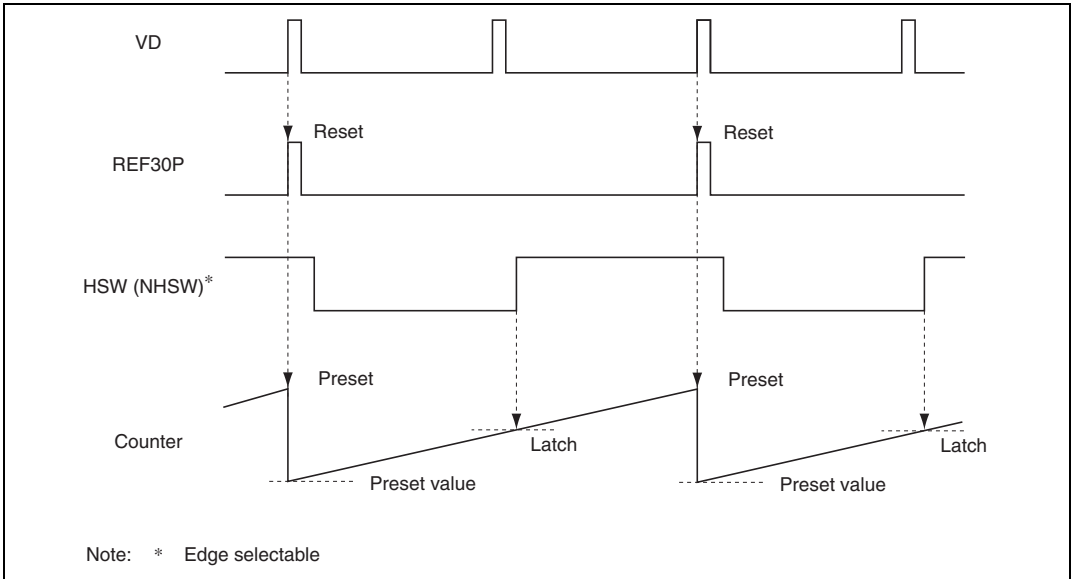
The drum phase error detector detects the phase error based on the reference value set in the drum phase preset data register 1 and 2 (DPPR1, DPPR2). The reference values set in DPPR1 and DPPR2 are preset in the counter by the REF30P signal, and counted up by the clock selected. The latch of the error data can be selected between the rising or falling edge of HSW (NHSW). The error data detected in the error data automatic transmission mode (DFEPS bit of DFUCR = 0) is sent to the digital filter circuit automatically. In software transmission mode (DFEPS bit of DFUCR = 1), the data written in DPER1 and DPER2 is sent to the digital filter circuit. The error data is signed binary. It takes a positive number (+) if the phase is behind the specified phase, a negative number (-) if in advance of the specified phase, or 0 if it had no phase error (revolving at the specified phase). Figures 28.30 and 28.31 show examples of operation to detect a drum phase error.

**Drum Phase Error Detection Counter:** The drum phase error detection counter stops the counter when overflow or latch occurred. At the same time, it generates an interrupt request (IRRDRM3), setting the overflow flag (DPOVF) if overflow occurred. Clear DPOVF by writing 0 after reading 1. If setting the flag and writing 0 take place simultaneously, the latter is nullified.

**Interrupt Request:** IRRDRM3 is generated by the HSW (NHSW) signal latch and the overflow of the error detection counter.



**Figure 28.30 Drum Phase Control in Playback Mode (HSW Rising Edge Selected)**



**Figure 28.31 Drum Phase Control in Record Mode (HSW RIsing Edge Selected)**

### 28.7.6 Phase Comparison

The phase comparison circuit takes measures of the difference of time between the reference signal and the comparing signal with a digital counter. The REF30 signal is used for the reference signal, and the HSW signal (VideoFF) or HHSW signal (NarrowFF) from the HSW timing generator is used for the comparing signal. In record mode, however, the phase of the REF30 signal is the same as that of the vertical sync signal (Vsync) because the reference signal generator (REF30 generator) is reset by the vertical sync signal (Vsync) in the video signals.

The error detection counter performs the data latching operation at the rising or falling edge of the HSW signal. The digital filter circuit performs computation using this data as 20-bit phase error data. After processing and adding the phase error data and the speed error data from the drum speed control system, the digital filter circuit sends the data as the error data of the drum system to the PWM modulation circuit.

## 28.8 Capstan Speed Error Detector

### 28.8.1 Overview

Capstan speed control operates so as to hold the capstan motor at a constant revolution speed, by measuring the period of the CFG signal. A digital counter detects the speed deviation from a preset value. The speed error data is added to phase error data in a digital filter. This filter controls a pulse-width modulated (PWM) output, which controls the revolution speed and phase of the capstan motor.

The CFG input signal is downloaded by the comparator circuit, then reshaped into a square wave by a reshaping circuit, divided by the CFG divider, and sent to the speed error detector as the DVCFG signal.

The speed error detector uses the system clock to measure the period of the DVCFG signal, and detects the deviation from a preset data value. The preset data is the value that would result from measuring the DVCFG signal period with the clock signal if the capstan motor was running at the correct speed.

The error detector operates by latching a counter value when it detects an edge of the DVCFG signal. The latched count provides 16 bits of speed error data for the digital filter to operate on. The digital filter adds the speed error data to phase error data from the capstan phase control system, then sends the result to the pulse-width modulator as capstan error data.

### 28.8.2 Block Diagram

Figure 28.32 shows a block diagram of the capstan speed error detector.

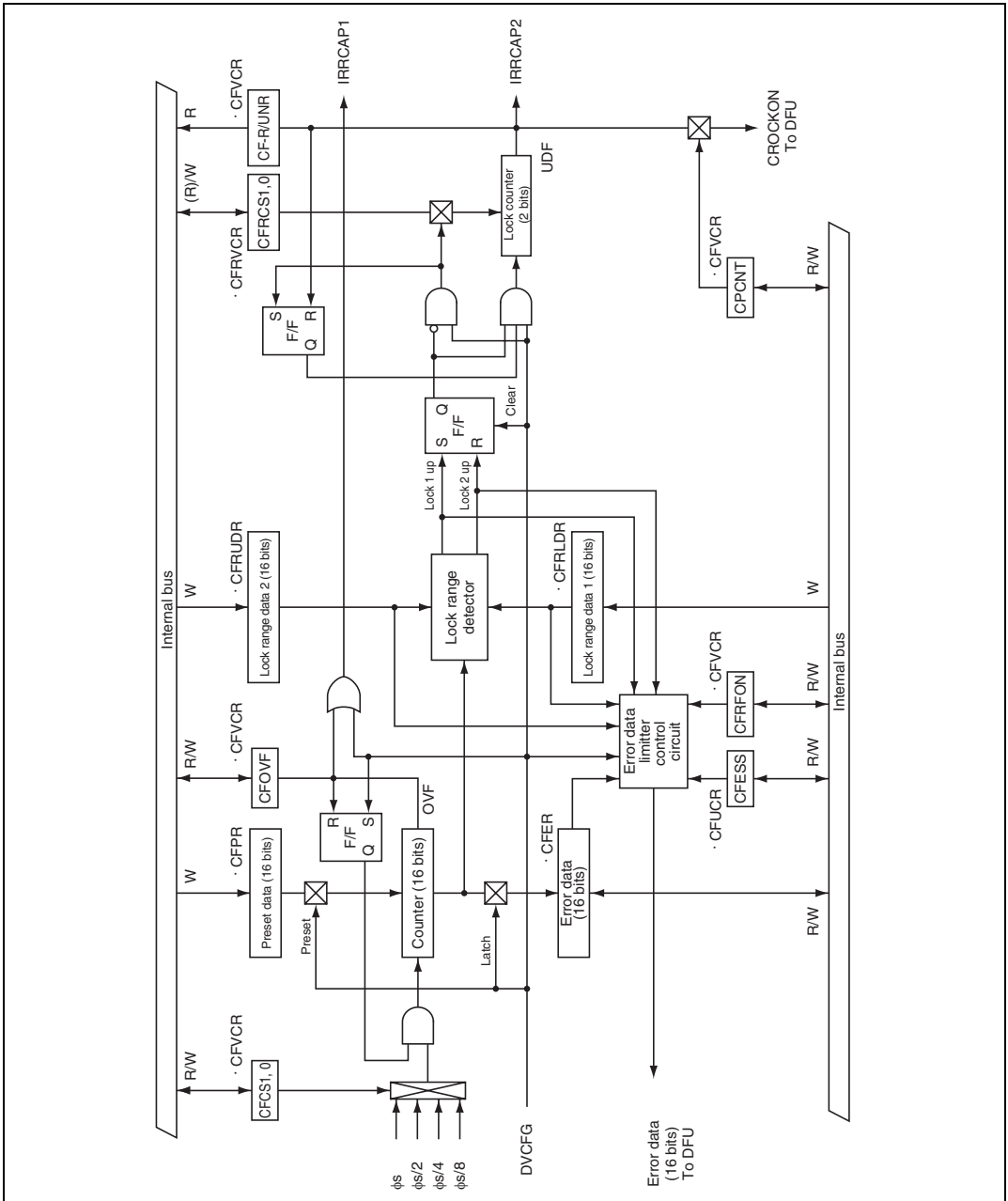


Figure 28.32 Block Diagram of Capstan Speed Error Detector



### 28.8.3 Register Configuration

Table 28.11 shows the register configuration of the capstan speed error detector.

**Table 28.11 Register Configuration**

Name	Abbrev.	R/W	Size	Initial Value	Address
CFG speed preset data register	CFPR	W	Word	H'0000	H'FD050
CFG speed error data register	CFER	R/W	Word	H'0000	H'FD052
CFG lock UPPER data register	CFRUDR	W	Word	H'7FFF	H'FD054
CFG lock LOWER data register	CFRLDR	W	Word	H'8000	H'FD056
Capstan speed error detection control register	CFVCR	R/W	Byte	H'00	H'FD058

### 28.8.4 Register Descriptions

#### (1) CFG Speed Preset Data Register (CFPR)

Bit:	15	14	13	12	11	10	9	8	7	6	5	4	3	2	1	0
	<input type="checkbox"/>	<input type="checkbox"/>	<input type="checkbox"/>	<input type="checkbox"/>	<input type="checkbox"/>	<input type="checkbox"/>	<input type="checkbox"/>	<input type="checkbox"/>	<input type="checkbox"/>	<input type="checkbox"/>	<input type="checkbox"/>	<input type="checkbox"/>	<input type="checkbox"/>	<input type="checkbox"/>	<input type="checkbox"/>	<input type="checkbox"/>
Initial value :	0	0	0	0	0	0	0	0	0	0	0	0	0	0	0	0
R/W :	W	W	W	W	W	W	W	W	W	W	W	W	W	W	W	W

The 16-bit preset data that defines the specified CFG speed is set in CFPR. The preset data is referenced to H'8000\*, and can be calculated from the following equation.

$$\text{CFG speed preset data} = \text{H}'8000 - \left( \frac{\phi_s/n}{\text{DVCFG frequency}} - 2 \right)$$

$\phi_s$ : Servo clock frequency in Hz ( $f_{\text{osc}}/2$ )

DVCFG frequency: In Hz

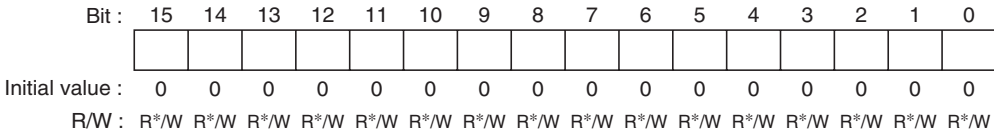
The constant 2 is the preset interval (see figure 28.33).

$\phi_s/n$ : Clock source of the selected counter

CFPR is a 16-bit write-only register. CFPR is accessible by word access only. Byte access gives unassured results. No read is valid. If a read is attempted, an undetermined value is read out. CFPR is initialized to H'0000 by a reset, stand-by or module stop.

Note: \* The preset data value is calculated so that the counter will reach H'8000 when the error is zero. When the counter value is latched as error data in the CFG speed error data register (CFER), however, it is converted to a value referenced to H'0000.

## (2) CFG Speed Error Data Register (CFER)

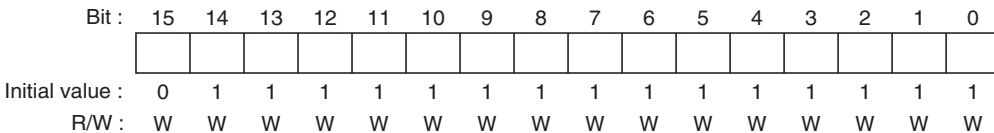


Note: \* Note that only detected error data can be read.

CFER is a 16-bit data register. When the speed of the capstan motor is correct, the data latched in CFER is H'0000. Negative data will be latched if the speed is too fast, and positive data if the speed is too slow. The CFER value is sent to the digital filter either automatically or by software. CFER is a 16-bit readable/writable register. CFER is accessible by word access only. Byte access gives unassured results. CFER is initialized to H'0000 by a reset, and in module stop mode and standby mode.

See the note on the CFG speed preset data register (CFPR) in section 28.8.4 (1), CFG Speed Present Data Register (CFPR).

## (3) CFG Lock UPPER Data Register (CFRUDR)



CFRUDR is a register used to set the lock range on the UPPER side when capstan speed lock is detected, and to set the limit value on the UPPER side when the limiter function is in use. When lock is being detected, if the capstan speed is detected within the lock range, the lock counter which has been set by the CFRCS1 and CFRCS0 bits of the CFVCR register counts down. If the set value of CFRCS1 and CFRCS0 matches the number of times of occurrence of locking, the computation of the digital filter in the capstan phase system can be controlled automatically. Also, if the CFG speed error data is beyond the CFRUDR value when the limiter function is in use, the CFRUDR value can be used as the data for computation by the digital filter. CFRUDR is a 16-bit write-only register. Only a word access is valid. If a byte access is attempted, operation is not assured. A read is invalid. If a read is attempted, an undetermined value is read out. It is initialized to H'7FFF by a reset, stand-by or module-stop.

**(4) CFG Lock LOWER Data Register (CFRLDR)**

Bit :	15	14	13	12	11	10	9	8	7	6	5	4	3	2	1	0
Initial value :	1	0	0	0	0	0	0	0	0	0	0	0	0	0	0	0
R/W :	W	W	W	W	W	W	W	W	W	W	W	W	W	W	W	W

CFRLDR is a register used to set the lock range on the LOWER side when capstan speed lock is detected, and to set the limit value on LOWER side when limiter function is in use.

When lock is being detected, if the drum speed is detected within the lock range, the lock counter which has been set by the CFRCS1 and CFRCS0 bits of the CFVCR register counts down. If the set value of CFRCS1 and CFRCS0 matches the number of times of occurrence of locking, the computation of the digital filter in the drum phase system can be controlled automatically. Also, if the CFG speed error data is under the CFRLDR value when the limiter function is in use, the CFRLDR value can be used as the data for computation by the digital filter.

CFRLDR is a 16-bit write-only register. Only a word access is valid. If a byte access is attempted, operation is not assured. No read is valid. If a read is attempted, an undetermined value is read out. It is initialized to H'8000 by a reset, stand-by or module-stop.

**(5) Capstan Speed Error Detection Control Register (CFVCR)**

Bit :	7	6	5	4	3	2	1	0
	CFCS1	CFCS0	CFOVF	CFRFON	CF-R/UNR	CPCNT	CFRCS1	CFRCS0
Initial value :	0	0	0	0	0	0	0	0
R/W :	R/W	R/W	R/(W)*1	R/W	R	R/W	(R)*2/W	(R)*2/W

- Notes: 1. Only 0 can be written.  
2. If read-accessed, the counter value is read out.

CFVCR controls the operation of capstan speed error detection.

CFVCR is an 8-bit readable/writable register. Bit 3 accepts only read, and bit 5 accepts only read and 0 write. It is initialized to H'00 by a reset, stand-by or module-stop.

**Bits 7 and 6—Clock Source Selection Bits (CFCS1, CFCS0):** CFCS1 and CFCS0 select the clock to be supplied to the counter. ( $\phi_s = f_{osc}/2$ )

Bit 7	Bit 6	Description
CFCS1	CFCS0	
0	0	$\phi_s$ (Initial value)
	1	$\phi_s/2$
1	0	$\phi_s/4$
	1	$\phi_s/8$

**Bit 5—Counter Overflow Flag (CFOVF):** The CFOVF flag indicates overflow of the 16-bit counter. It is cleared by writing 0. Write 0 after reading 1. Also, setting has the highest priority in this flag. If a flag set and 0 write occurs simultaneously, the latter is nullified.

**Bit 5**

CFOVF	Description	
0	Normal state	(Initial value)
1	Indicates that an overflow has occurred in the counter	

**Bit 4—Error Data Limit Function Selection Bit (CFRFON):** Makes the error data limit function valid. (Limit values are the values set in the lock range data register (CFRUDR, CFRLDR)).

**Bit 4**

CFRFON	Description	
0	Limit function off	(Initial value)
1	Limit function on	

**Bit 3—Capstan Lock Flag (CF-R/UNR):** Sets a flag if an underflow occurred in the capstan lock counter.

**Bit 3**

CF-R/UNR	Description	
0	Indicates that the capstan speed system is not locked	(Initial value)
1	Indicates that the capstan speed system is locked	

**Bit 2—Capstan Phase System Filter Computation Automatic Start Bit (CPCNT):** Sets on the filter computation of the phase system if an underflow occurred in the capstan lock counter.

**Bit 2**

CPCNT	Description	
0	Does not perform the filter computation by detection of the capstan lock	(Initial value)
1	Set on the filter computation of the phase system when capstan lock is detected	

**Bits 1 and 0—Capstan Lock Counter Setting Bits (CFRCS1, CFRCS0):** Sets the number of times where drum lock has been determined (DVCFG has been detected in the range set by the lock range data register). It sets the capstan lock flag if it detected the set number of times of occurrence of capstan lock. If a DVCFG signal is detected outside the lock range after data is written in CFRCS1 and CFRCS0, data is stored in the lock counter.

Note: If CFRCS1 or CFRCS0 is read-accessed, the counter value is read out. If bit 3 (capstan lock flag) is 1 and the capstan lock counter's value is 3, it indicates that the capstan speed system is locked. The capstan lock counter stops until lock is released after underflow.

Bit 1	Bit 0	Description
CFRCS1	CFRCS0	
0	0	Underflow after lock was detected once (Initial value)
	1	Underflow after lock was detected twice
1	0	Underflow after lock was detected three times
	1	Underflow after lock was detected four times

### 28.8.5 Description of Operation

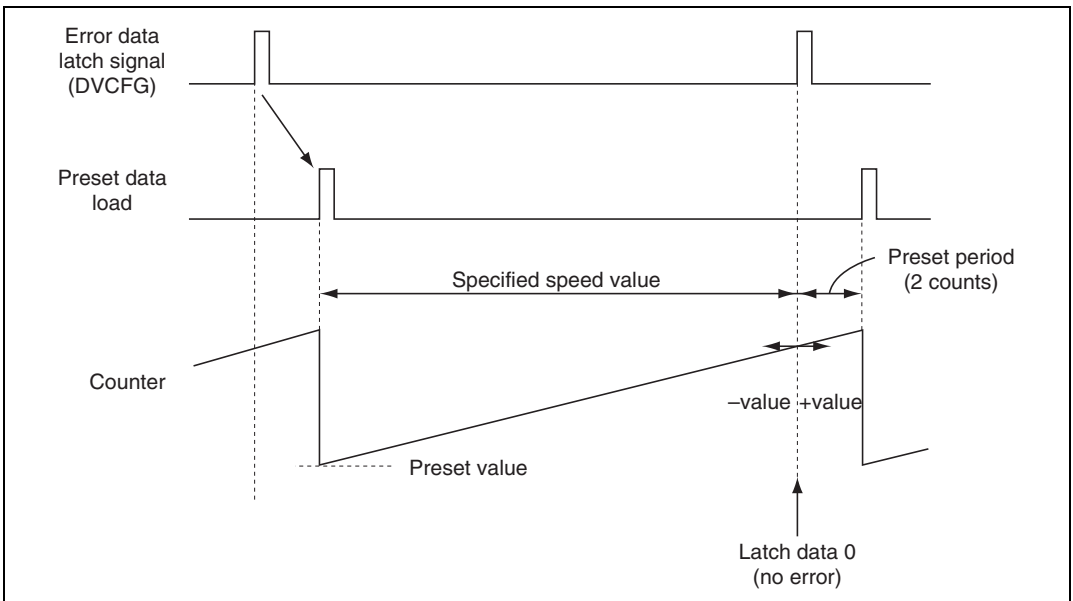
The capstan speed error detector detects the speed error based on the reference value set in the CFG speed preset register (CFPR). The reference value set in CFPR is preset in the counter by the DVCFG signal, and counts down by the selected clock. The timing of the counter presetting and the error data latching can be selected between the rising or falling edge of the DVCFG signal. See description of DVCFG control register (CDVC), in section 28.14.3, CFG Frequency Divider. The error data detected is sent to the digital filter circuit. The error data is signed binaries. It takes a positive number (+) if the speed is slower than the specified speed, a negative number (-) if the speed is faster, or 0 if it had no error (revolving at the specified speed). Figure 28.33 shows an example of operation to detect the capstan speed.

**Setting the Error Data Limit:** A limit can be set to the error data sent to the digital filter circuit using the CFG lock data register (CFRUDR, CFRLDR). Set the upper limit of the error data in CFRUDR and the lower limit in CFRLDR, and write 1 in the CFRFON bit. If the error data is beyond the limit range, the CFRLDR value is sent if a negative number is latched, or the CFRUDR value is sent if a positive one is latched, as a limit value. Be sure to turn off the limit setting (CFRFON = 0) when you set the limit value. If the limit was set with the limit setting on (CFRFON = 1), result of computation is not assured.

**Lock Detection:** If error data was detected within the lock range set in the lock data register, the capstan lock flag (CF-R/UNR) is set by the number of the times of occurrence of locking set by the CFRCS1 and CFRCS0 bits, and an interrupt is requested (IRRCAP2) at the same time. The number of the occurrence of locking (once to 4 times) can be specified when setting the flag. Use the CFRCS1 and CFRCS0 bits for this purpose. Also, if bit 5 (CPHA bit) of the capstan system digital filter control register (CFIC) is 0 (phased system digital filter computation off) and the DPCNT bit is 1, turning on/off of the phase system digital filter computation can be controlled automatically by the status of lock detection.

**Capstan System sSpeed Error Detection Counter:** The capstan system speed error detection counter stops the counter and sets the overflow flag (CFOVF) when overflow occurred. At the same time, it generates an interrupt request (IRRCAP1). Clear CFOVF by writing 0 after reading 1. If setting the flag and writing 0 take place simultaneously, the latter is nullified.

**Interrupt Request:** IRRCAP1 is generated by the DVCFG signal latch and the overflow of the error detection counter. IRRCAP2 is generated by detection of lock (after the detection of the number of times of setting).



**Figure 28.33 Example of the Operation of the Capstan Speed Error Detection**

## 28.9 Capstan Phase Error Detector

### 28.9.1 Overview

The capstan phase control system is required to start operation after the capstan motor has arrived at the specified speed under the control of the speed control system. The capstan phase control system operates in the following way in record/playback mode.

In record mode: Controls the tape running so that it may run at a specified speed together with the speed control system.

In playback mode: Controls the tape running so that the recorded track may be traced correctly. Any error deviated from the reference phase is detected by the digital counter. This phase error data and the speed error data is processed and added by the digital filter circuit to control the PWM output. The phase and speed of the capstan, in turn, is controlled by this PWM output. The control signal of the capstan phase control in REC mode differs from that in PB mode. In REC mode, the control is performed by the DVCFG2 signal which is generated by dividing the frequencies of the reference signal (REF30P or CREF) and the CFG signal. In PB mode, it is performed by divided rising signal (DVCTL) of the reference signal (CAPREF30) and the playback control pulse (PB-CTL).

The reference signal in record and playback modes are as follows.

In record mode:  $1/2$  Vsync signal extracted from the video signal to be recorded

In playback mode: Signal generated by dividing the PB-CTL signal (DVCTL) at its rising edge

### 28.9.2 Block Diagram

Figure 28.34 shows the block diagram of the capstan phase error detector.

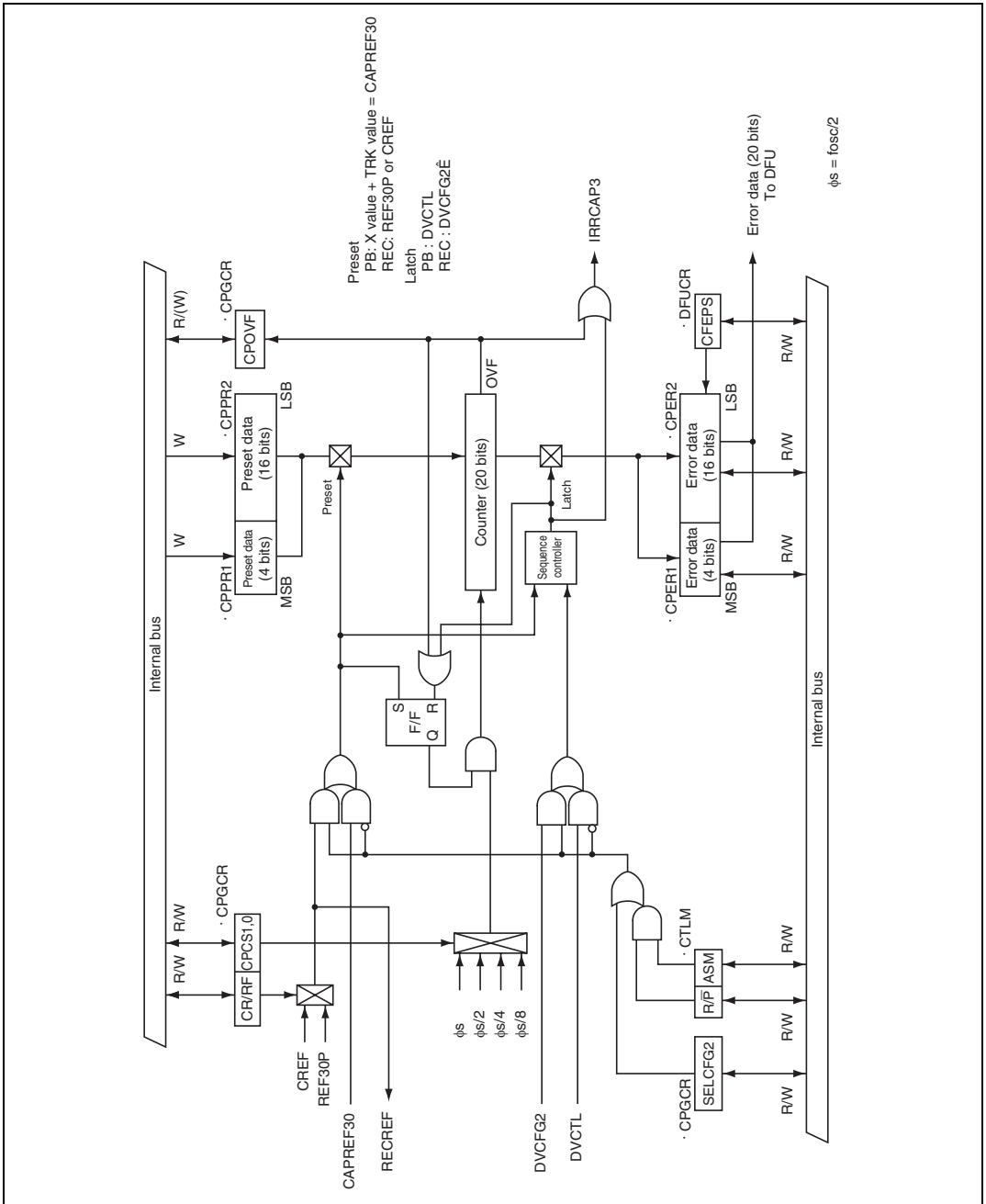


Figure 28.34 Block Diagram of Capstan Phase Error Detector



### 28.9.3 Register Configuration

Table 28.12 shows the register configuration of the capstan phase error detector.

**Table 28.12 Register Configuration**

<b>Name</b>	<b>Abbrev.</b>	<b>R/W</b>	<b>Size</b>	<b>Initial Value</b>	<b>Address</b>
Capstan phase preset data register 1	CPPR1	W	Byte	H'F0	H'FD05C
Capstan phase preset data register 2	CPPR2	W	Word	H'0000	H'FD05A
Capstan phase error data register 1	CPER1	R/W	Byte	H'F0	H'FD05D
Capstan phase error data register 2	CPER2	R/W	Word	H'0000	H'FD05E
Capstan phase error detection control register	CPGCR	R/W	Byte	H'07	H'FD059

## 28.9.4 Register Descriptions

### (1) Capstan Phase Preset Data Registers (CPPR1, CPPR2)

#### CPPR1

Bit :	7	6	5	4	3	2	1	0
	—	—	—	—				
Initial value :	1	1	1	1	0	0	0	0
R/W :	—	—	—	—	W	W	W	W

#### CPPR2

Bit :	15	14	13	12	11	10	9	8	7	6	5	4	3	2	1	0
Initial value :	0	0	0	0	0	0	0	0	0	0	0	0	0	0	0	0
R/W :	W	W	W	W	W	W	W	W	W	W	W	W	W	W	W	W

The 20-bit preset data that defines the specified capstan phase is set in CPPR1 and CPPR2. The 20 bits are weighted as follows. Bit 3 of CPPR1 is the MSB. Bit 0 of CPPR2 is the LSB. When CPPR2 is written to, the 20-bit preset data, including CPPR1, is loaded into the preset circuit. Write to CPPR1 first, and CPPR2 next. The preset data is referenced to H'80000\*, and can be calculated from the following equation.

Target phase difference = Rreference signal frequency/2

Capstan phase preset data = H'80000 – ( $\phi$ s/n × target phase difference)

$\phi$ s: Servo clock frequency in Hz ( $f_{osc}/2$ )

$\phi$ s/n: Clock source of selected counter

CPPR2 is accessible by word access only. Byte access gives unassured results. Reads are disabled. If read is attempted to CPPR1 or CPPR2, an undetermined value is read out. CPPR1 and CPPR2 are initialized to H'F0 and H'0000 by a reset, and in standby mode.

Note: \* The preset data value is calculated so that the counter will reach H'80000 when the error is zero. When the counter value is latched as error data in the capstan phase error data registers (CPEP1 and CPEP2), however, it is converted to a value referenced to H'00000.

**(2) Capstan Phase Error Data Registers (CPER1, CPER2)**

Bit :	7	6	5	4	3	2	1	0								
	—	—	—	—												
Initial value :	1	1	1	1	0	0	0	0								
R/W :	—	—	—	—	R*/W	R*/W	R*/W	R*/W								
Bit :	15	14	13	12	11	10	9	8	7	6	5	4	3	2	1	0
Initial value :	0	0	0	0	0	0	0	0	0	0	0	0	0	0	0	0
R/W :	R*/W	R*/W	R*/W	R*/W	R*/W	R*/W	R*/W	R*/W	R*/W	R*/W	R*/W	R*/W	R*/W	R*/W	R*/W	R*/W

Note: \* Note that only detected error data can be read.

CPER1 and CPER2 constitute a 20-bit capstan phase error data register. The 20 bits are weighted as follows. Bit 3 of CPER1 is the MSB. Bit 0 of CPER2 is the LSB. When the rotational phase is correct, the data H'00000 is latched. Negative data will be latched if the phase leads the correct phase, and positive data if it lags. Values in CPER1 and CPER 2 are transferred to the digital filter circuit.

CPER1 and CPER are 20-bit readable/writable registers. When writing data to CPER1 and CPER2, write to CPER1 first, and then write to CPER2. CPER2 is accessible by word access only. Byte access gives unassured results. CPER1 and CPER2 are initialized to H'F0 and H'0000 by a reset, and in standby mode.

See the note on the capstan phase preset data registers (CPPR1 and CPPR2) in section 28.9.4 (1), Capstan Phase Present Data Registers (CPPR1, CPPR2).

**(3) Capstan Phase Error Detection Control Register (CPGCR)**

Bit :	7	6	5	4	3	2	1	0
	CPCS1	CPCS0	CPOVF	CR/RF	SELCFG2	—	—	—
Initial value :	0	0	0	0	0	1	1	1
R/W :	R/W	R/W	R/(W)*	R/W	R/W	—	—	—

Note: \* Only 0 can be written

CPGCR controls the operation of capstan phase error detection.

CPGCR is an 8-bit readable/writable register. Bits 2 to 0 are reserved, bit 5 accepts only read and 0 write.

It is initialized to H'07 by a reset or stand-by.

**Bits 7 and 6—Clock Source Selection Bits (CPCS1, CPCS0):** Select the clock supplied to the counter. ( $\phi_s = f_{osc}/2$ )

Bit 7		Bit 6	
CPCS1	CPCS0	Description	
0	0	$\phi_s$ (Initial value)	
	1	$\phi_s/2$	
1	0	$\phi_s/4$	
	1	$\phi_s/8$	

**Bit 5—Counter Overflow Flag (CPOVF):** CPOVF flag indicates the overflow of the 20-bit counter. It is cleared by writing 0. Write 0 after reading 1. Also, setting has the highest priority in this flag. If a flag set and 0 write occurs simultaneously, the latter is nullified.

Bit 5	
CPOVF	Description
0	Normal state (Initial value)
1	Indicates that an overflow has occurred in the counter

**Bit 4—Preset Signal Selection Bit (CR/RF):** Selects the preset signal.

Bit 4	
CR/RF	Description
0	Presets REF30P signal (Initial value)
1	Presets CREF signal

**Bit 3—Preset and Latch Signal Selection Bit (SELCFG2):** Selects the counter preset signal and the error data latch signal data in PB (ASM) mode.

Bit 3	
SELCFG2	Description
0	Presets CAPREF30 signal; latches DVCTL signal (Initial value)
1	Presets REF30P (CREF) signal; latches DVCFG2 signal

**Bits 2 to 0—Reserved:** No read or write is valid.

### 28.9.5 Description of Operation

The capstan phase error detector detects the phase error based on the reference value set in the capstan specified phase preset data register 1 and 2 (CPPR1, CPPR2). The reference values set in CPPR1 and CPPR2 are preset in the counter by the REF30P (CREF) signal or CAPREF30 signal, and counted up by the clock selected. The latching of the error data is performed by DVCTL or DVCFG2.

The error data detected in the error data automatic transmission mode (CFEPS bit of DFUCR = 0) is sent to the digital filter circuit automatically. In software transmission mode (CFEPS bit of DFUCR = 1), the data written in CPER1 and CPER2 is sent to the digital filter circuit. The error data is signed binary. It takes a positive number (+) if the phase is behind the specified phase, a negative number (-) if in advance of the specified phase, or 0 if it had no phase error (revolving at the specified phase). Figures 28.35 and 28.36 show examples of operation to detect a capstan phase error.

**Capstan Phase Error Detection Counter:** The capstan phase error detection counter stops the counter when overflow or latch occurred. At the same time, it generates an interrupt request (IRRCAP3), setting the overflow flag (CPOVF) if overflow occurred. Clear CPOVF by writing 0 after reading 1. If setting the flag and writing 0 take place simultaneously, the latter is nullified.

**Interrupt Request:** IRRCAP3 is generated by the DVCTL or DVCFG2 signal latch and the overflow of the error detection counter.

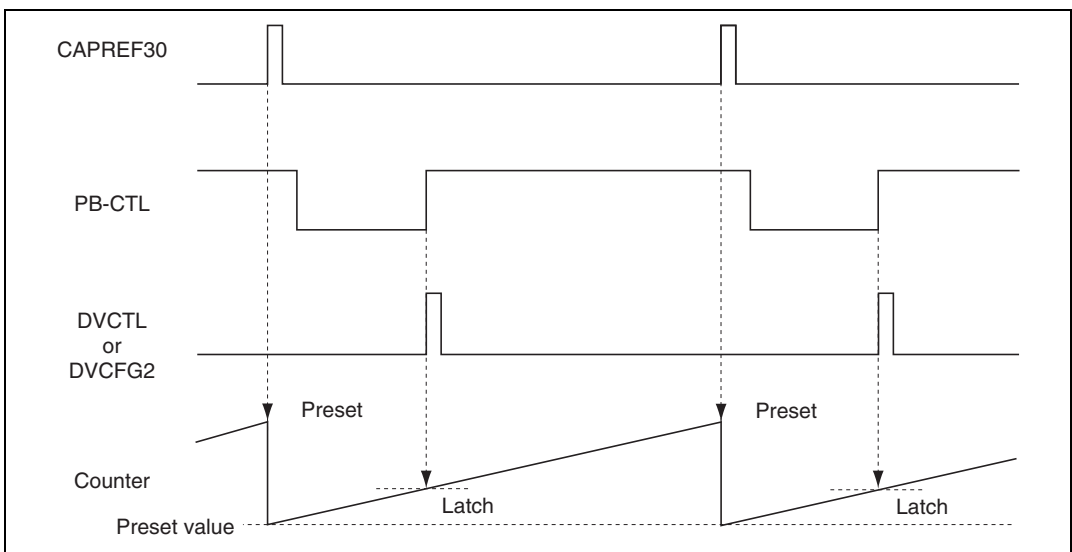
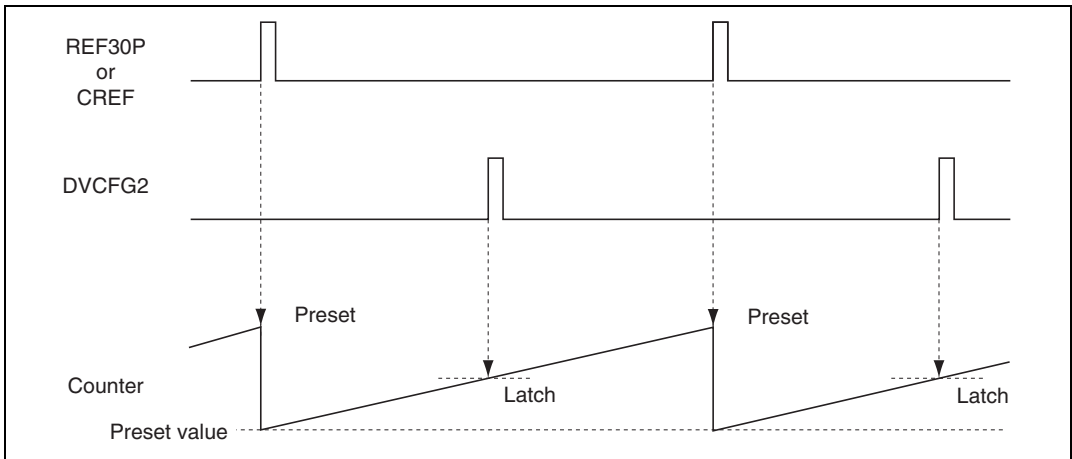


Figure 28.35 Capstan Phase Control in Playback Mode



**Figure 28.36 Capstan Phase Control in Record Mode**

## 28.10 X-Value and Tracking Adjustment Circuit

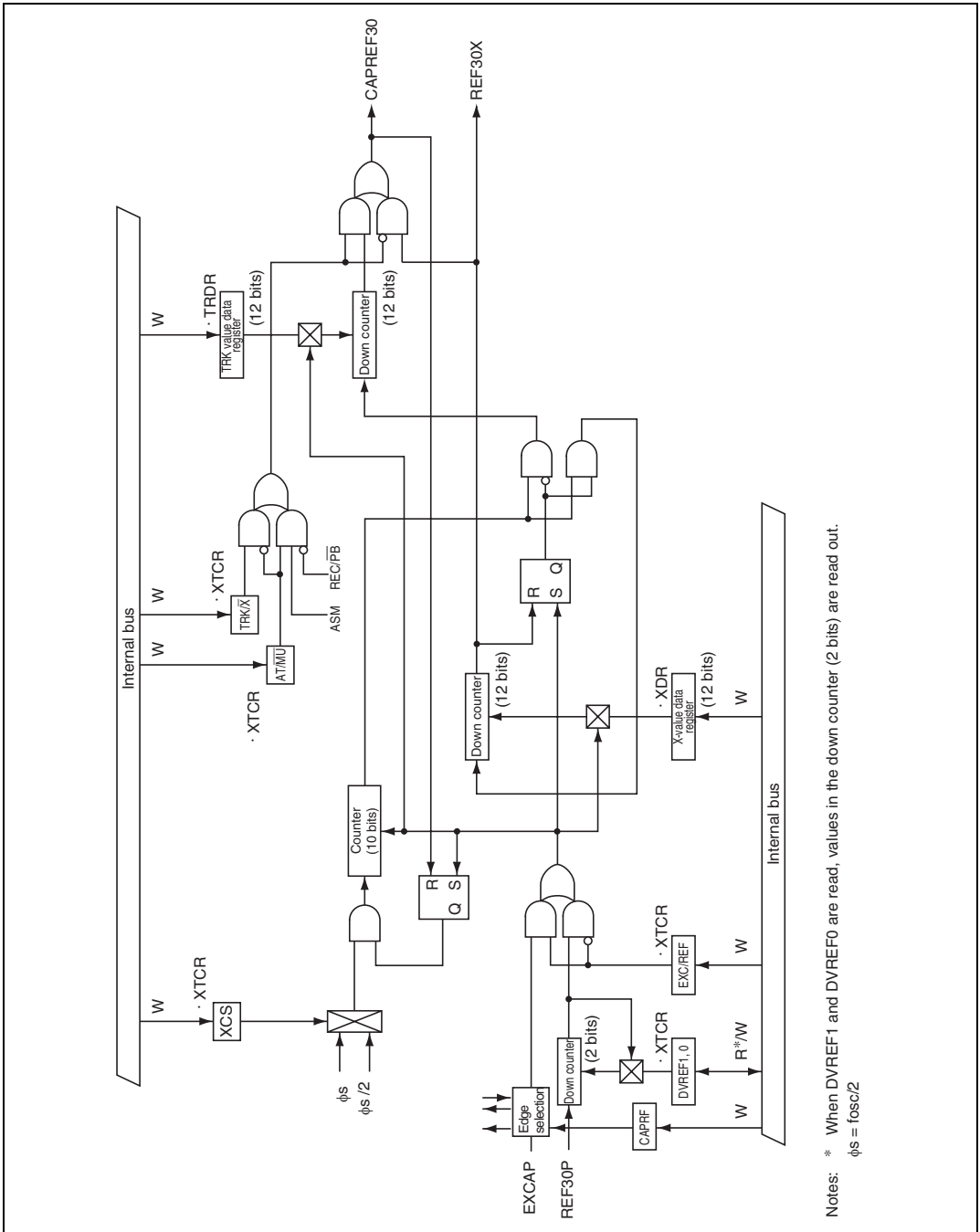
### 28.10.1 Overview

To maintain compatibility with other VCRs, an on-chip adjustment circuit adjusts the phase of the reference signal (internal reference signal (REF30) or external reference signal (EXCAP)) during playback. Because of manufacturing tolerances, the physical distance between the video head and control head (the X-value: 79.244 mm) may vary from set to set, so when a tape that was recorded on a different set is played back, the phase of the reference signal may need to be adjusted. The adjustment can be made by a register setting. The same setting can adjust the rotational phase of the capstan motor to maintain positional alignment (tracking alignment) of the video head with the recorded tracks in autotracking, or when tracks that were recorded with an EP head are traced by a wider head. These tracking adjustments can be made by acquisition of the envelope signal by the A/D converter.

### 28.10.2 Block Diagram

The adjustment circuit consists of a 10-bit counter clocked by the servo clock ( $\phi$ s or  $\phi$ s/2), and two down-counters with load register. Individual setting of X-value adjustment can be made by the X-value data register (XDR) and tracking adjustment by the TRK data register (TRDR). The reference signal clears the 10-bit counter and sets the load register value in the down-counter with two load registers. After the adjusted reference signal is generated, clock supply stops and the circuit halts until the next reference signal is input. The REF30 signal can be divided (by 2 to 4) as necessary.

Figure 28.37 shows a block diagram.



**Figure 28.37** Block Diagram of X-Value Adjustment Circuit



### 28.10.3 Register Descriptions

#### (1) Register Configuration

Table 28.13 shows the register configuration of X-value adjustment and tracking adjustment circuits.

**Table 28.13 Register Configuration**

Name	Abbrev.	R/W	Size	Initial Value	Address
X-value and TRK-value control register	XTCR	R/W	Byte	H'80	H'FD074
X-value data register	XDR	W	Word	H'F000	H'FD070
TRK-value data register	TRDR	W	Word	H'F000	H'FD072

#### (2) X-value and TRK-value Control Register (XTCR)

Bit :	7	6	5	4	3	2	1	0
	—	CAPRF	AT/MU	TRK/X	EXC/REF	XCS	DVREF1	DVREF0
Initial value :	1	0	0	0	0	0	0	0
R/W :	—	W	W	W	W	W	R/W	R/W

XTCR is an 8-bit register to determine the X-value and TRK-value adjustment circuits. Bits 6 to 2 are write-only bits. No read is valid. If a read is attempted, an undetermined value is read out. Bits 1 and 0 are readable/writable bits. XTCR accepts only a byte access. If a word access is attempted, operation is unassured.

It is initialized to H'80 by a reset, stand-by or module stop.

**Bit 7—Reserved:** No write is valid. If a read is attempted, an undetermined value is read out.

**Bit 6—External Sync Signal Edge Selection Bit (CAPRF):** Selects the EXCAP edge when a selection is made to generate external sync signals.

#### Bit 6

CAPRF	Description
0	Signal generated at the rising edge of EXCAP (Initial value)
1	Signal generated at both edges of EXCAP

**Bit 5—Capstan Phase Correction Auto/Manual Selection Bit ( $\overline{AT/MU}$ ):** Selects whether the generation of the correction reference signal (CAPREF30) for capstan phase control is controlled automatically or manually depending on the status of the ASM and REC/PB bits of the CTL mode register.

**Bit 5**

$\overline{AT/MU}$	Description	
0	Manual mode	(Initial value)
1	Auto mode	

**Bit 4—Capstan Phase Correction Register Selection Bit ( $\overline{TRK/X}$ ):** Determines the method to generate the CAPREF30 signal when the  $\overline{AT/MU}$  bit is 0.

**Bit 4**

$\overline{TRK/X}$	Description	
0	Generates CAPREF30 only by the set value of XDR	(Initial value)
1	Generates CAPREF30 by the set values of XDR and TRDR	

**Bit 3—Reference Signal Selection Bit ( $\overline{EXC/REF}$ ):** Selects the reference signal to generate the correction reference signal (CAPREF30).

**Bit 3**

$\overline{EXC/REF}$	Description	
0	Generates the signal based on REF30P	(Initial value)
1	Generates the signal based on the external reference signal	

**Bit 2—Clock Source Selection Bit (XCS):** Selects the clock source to be supplied to the 10-bit counter.

**Bit 2**

XCS	Description	
0	$\phi_s$	(Initial value)
1	$\phi_s/2$	

**Bits 1 and 0—REF30P Division Ratio Selection Bits (DVREF1, DVREF0):** Select the division value of REF30P. If it is read-accessed, the counter value is read out. (The selected division value is set by the UDF of the counter.)

Bit 1	Bit 0	Description
DVREF1	DVREF0	
0	0	Division in 1 (Initial value)
	1	Division in 2
1	0	Division in 3
	1	Division in 4

### (3) X-Value Data Register (XDR)

Bit:	15	14	13	12	11	10	9	8	7	6	5	4	3	2	1	0
	—	—	—	—	XD11	XD10	XD9	XD8	XD7	XD6	XD5	XD4	XD3	XD2	XD1	XD0
Initial value:	1	1	1	1	0	0	0	0	0	0	0	0	0	0	0	0
R/W:	—	—	—	—	W	W	W	W	W	W	W	W	W	W	W	W

The X-value data register (XDR) is a 16-bit write-only register. No read is valid. If a read is attempted, an undefined value is read out. XDR accepts only a word-access. If a byte access is attempted, operation is not assured.

Set X-value correction data to XDR, except a value which is beyond the cycle of the CTL pulse. If  $\overline{AT/M\bar{U}} = 0$ ,  $\overline{TRK/X} = 0$  was set, CAPREF30 can be generated only by the setting of XDR. Set an X-value and TRK correction value in PB mode, and an X-value in REC mode.

It is initialized to H'F000 by a reset, stand-by or module stop.

### (4) TRK-Value Data Register (TRDR)

Bit:	15	14	13	12	11	10	9	8	7	6	5	4	3	2	1	0
	—	—	—	—	TRD11	TRD10	TRD9	TRD8	TRD7	TRD6	TRD5	TRD4	TRD3	TRD2	TRD1	TRD0
Initial value:	1	1	1	1	0	0	0	0	0	0	0	0	0	0	0	0
R/W:	—	—	—	—	W	W	W	W	W	W	W	W	W	W	W	W

The TRK-value data register (TRDR) is a 16-bit write-only register. No read is valid. If a read is attempted, an undefined value is read out. TRDR accepts only a word-access. If a byte access is attempted, operation is not assured.

Set a TRK-value correction data to TRDR, except a value which is beyond the cycle of the CTL pulse. It is initialized to H'F000 by a reset, stand-by or module stop.

## 28.11 Digital Filters

### 28.11.1 Overview

The digital filters required in servo control make extensive use of multiply-accumulate operations on signed integers (error data) and coefficients. A filter computation circuit (digital filter computation circuit) is provided in on-chip hardware to reduce the load on software, and to improve processing efficiency. Figure 28.38 shows a block diagram of the digital filter computation circuit configuration.

The filter computation circuit includes a high-speed 24-bit  $\times$  16-bit multiplier-accumulator, an arithmetic buffer, and an I/O processor. The digital filter computations are carried out by the high-speed multiplier-accumulator. The arithmetic buffer stores coefficients and gain constants needed in the filter computations, which are referenced by the high-speed multiplier-accumulator.

The I/O processor is activated by a frequency generator signal, and determines what operation is carried out. When activated, it reads the speed error and phase error from the speed and phase error detectors and sends them to the accumulator.

When the filter computation is completed, the I/O processor reads the result from the accumulator and sends it to a 12-bit PWM. At this time, the accumulation result gain can be controlled.

## 28.11.2 Block Diagram

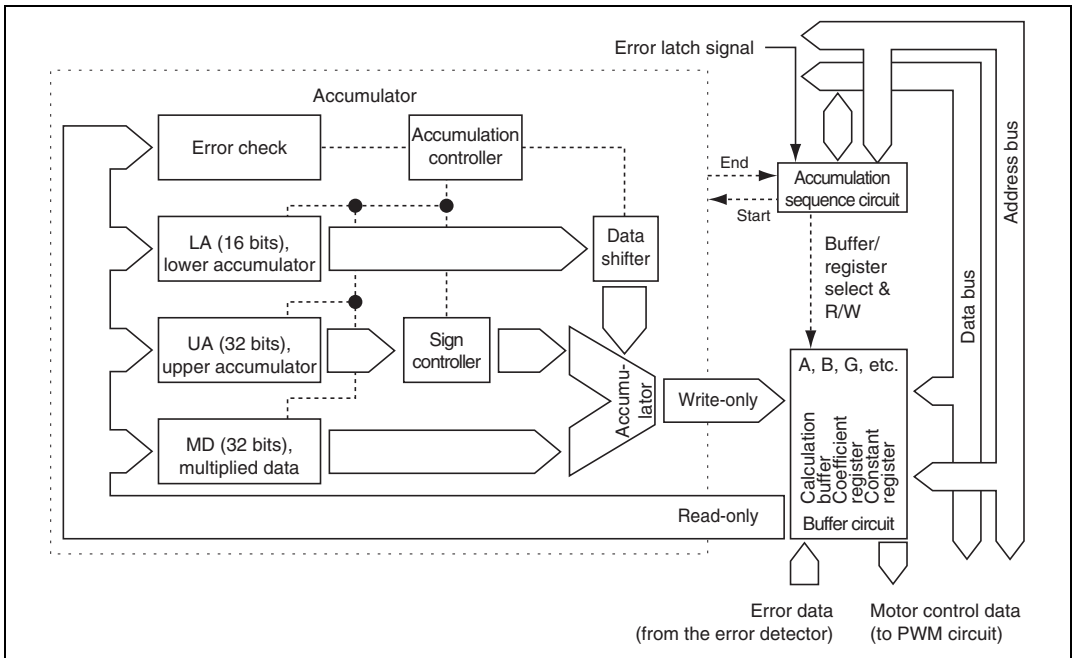


Figure 28.38 Block Diagram of Digital Filter Circuit

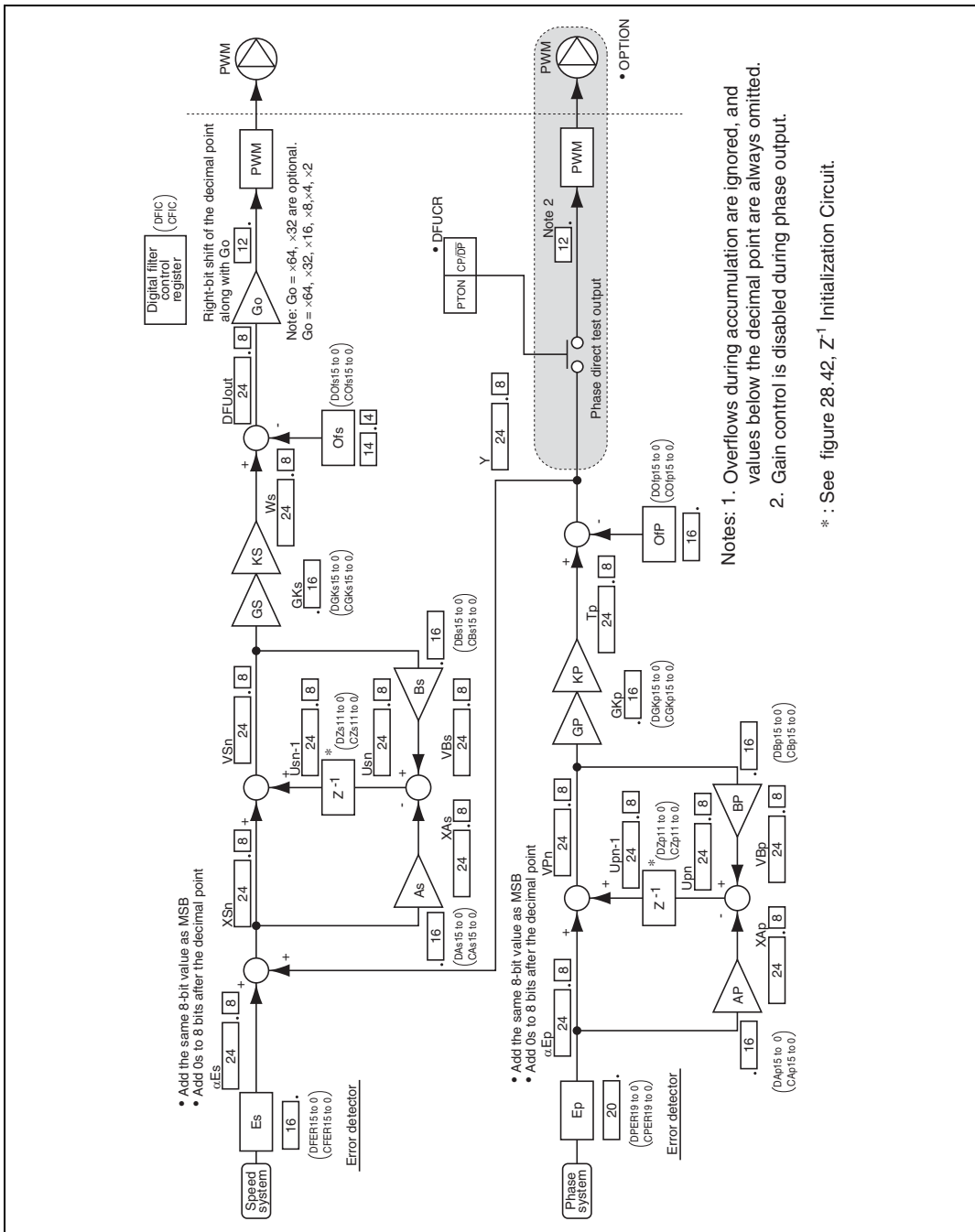


Figure 28.39 Digital Filter Representation

### 28.11.3 Arithmetic Buffer

This buffer stores computational data used in the digital filters. See table 28.14. Write access is limited to the gain and coefficient data ( $Z^{-1}$ ). Other data is used by hardware. None of the data can be read.

**Table 28.14 Arithmetic Buffer Register Configuration**

	Arithmetic Data	Gain or Coefficient	Processing Data	Buffer Data Length		
				16 bits	16 bits	16 bits
Phase system	$E_p$			Valid	Non-existent	Valid
	$U_{pn}$			Valid	Non-existent	Valid
	$U_{pn-1} (Z^{-1})$			Valid	Non-existent	Valid
	$V_{pn}$			Valid	Non-existent	Valid
	$T_p$			Valid	Non-existent	Valid
	$Y$			Valid	Non-existent	Valid
		$A_p$			Valid	Valid
		$B_p$			Valid	Valid
		$GK_p$			Valid	Valid
		$O_{fp}$			Valid	Valid
		$A_p \times E_{pn}$		Valid	Valid	
		$B_p \times V_{pn}$		Valid	Valid	
Speed system	$E_s$			Valid	Non-existent	Valid
	$X_{sn}$			Valid	Non-existent	Valid
	$U_{sn}$			Valid	Non-existent	Valid
	$U_{sn-1} (Z^{-1}s)$			Valid	Non-existent	Valid
	$V_{sn}$			Valid	Non-existent	Valid
	$W_s$			Valid	Non-existent	Valid
		$A_s$			Valid	Valid
		$B_s$			Valid	Valid
		$GK_s$			Valid	Valid
		$O_{fs}$			Valid	Valid
		$A_s \times X_{sn}$		Valid	Valid	
		$B_s \times V_{sn}$		Valid	Valid	
Error output	PWM			Valid	Non-existent	Valid

Legend:  Valid bits  
 Non-existent bits

↑  
Decimal point

### 28.11.4 Register Configuration

Table 28.15 shows the register configuration of the digital filter computation circuit.

**Table 28.15 Register Configuration**

<b>Name</b>	<b>Abbrev.</b>	<b>R/W</b>	<b>Size</b>	<b>Initial Value</b>	<b>Address</b>
Capstan phase gain constant	CGKp	W	Word	Undetermined	H'FD010
Capstan speed gain constant	CGKs	W	Word	Undetermined	H'FD012
Capstan phase coefficient A	CAP	W	Word	Undetermined	H'FD014
Capstan phase coefficient B	CBp	W	Word	Undetermined	H'FD016
Capstan speed coefficient A	CAs	W	Word	Undetermined	H'FD018
Capstan speed coefficient B	CBs	W	Word	Undetermined	H'FD01A
Capstan phase offset	COfp	W	Word	Undetermined	H'FD01C
Capstan speed offset	COfs	W	Word	Undetermined	H'FD01E
Drum phase gain constant	DGKp	W	Word	Undetermined	H'FD000
Drum speed gain constant	DGKs	W	Word	Undetermined	H'FD002
Drum phase coefficient A	DAP	W	Word	Undetermined	H'FD004
Drum phase coefficient B	DBp	W	Word	Undetermined	H'FD006
Drum speed coefficient A	DAs	W	Word	Undetermined	H'FD008
Drum speed coefficient B	DBs	W	Word	Undetermined	H'FD00A
Drum phase offset	DOfp	W	Word	Undetermined	H'FD00C
Drum speed offset	DOfs	W	Word	Undetermined	H'FD00E
Drum system speed delay initialization register	DZs	W	Word	H'F000	H'FD020
Drum system phase delay initialization register	DZp	W	Word	H'F000	H'FD022
Capstan system speed delay initialization register	CZs	W	Word	H'F000	H'FD024
Capstan system phase delay initialization register	CZp	W	Word	H'F000	H'FD026
Drum system digital filter control register	DFIC	R/W	Byte	H'80	H'FD028
Capstan system digital filter control register	CFIC	R/W	Byte	H'80	H'FD029
Digital filter control register	DFUCR	R/W	Byte	H'C0	H'FD02A



## 28.11.5 Register Descriptions

### (1) Gain Constants (DGKp, DGKs, CGKp, CGKs)

Bit :	15	14	13	12	11	10	9	8	7	6	5	4	3	2	1	0
Initial value :	*	*	*	*	*	*	*	*	*	*	*	*	*	*	*	*
R/W :	W	W	W	W	W	W	W	W	W	W	W	W	W	W	W	W

Note: \* Initial value is uncertain.

These registers are 16-bit write-only buffers that set accumulation gain of the digital filter. They cannot be read. They can be accessed by word access only. Accumulation gain can be set to gain 1 value as the maximum value. Byte access gives unassured results. If read is attempted, an undetermined value is read out.

These registers are not initialized by a reset or in standby mode. Be sure to write data in them before processing starts.

In the digital filter, output gain and accumulation gain can be adjusted separately. Take output gain into account when setting accumulation gain.

### (2) Coefficients (DAp, DBp, DAs, DBs, CAp, CBp, CAs, CBs)

Bit :	15	14	13	12	11	10	9	8	7	6	5	4	3	2	1	0
Initial value :	*	*	*	*	*	*	*	*	*	*	*	*	*	*	*	*
R/W :	W	W	W	W	W	W	W	W	W	W	W	W	W	W	W	W

Note: \* Initial value is uncertain.

These registers are 16-bit write-only buffers that determine the cutoff frequency f1 and f2. They cannot be read. They can be accessed by word access only. Byte access gives unassured results. If read is attempted, an undetermined value is read out.

These registers are not initialized by a reset or in standby mode. Be sure to write data in them before processing starts.

In the digital filter, output gain and accumulation gain can be adjusted separately. Take output gain into account when setting accumulation gain.

**(3) Offsets (DOfp, DOfs, COfp, COfs)**

Bit :	15	14	13	12	11	10	9	8	7	6	5	4	3	2	1	0
Initial value :	*	*	*	*	*	*	*	*	*	*	*	*	*	*	*	*
R/W :	W	W	W	W	W	W	W	W	W	W	W	W	W	W	W	W

Note: \* Initial value is uncertain.

These registers are 16-bit write-only buffers that set the offset level of digital filter output. They cannot be read. They can be accessed by word access only. Byte access gives unassured results. If read is attempted, an undetermined value is read out.

These registers are not initialized by a reset or in standby mode. Be sure to write data in them before processing starts.

In this digital filter, output gain adjustment ( $\times 1, 2, 4, 8, 16, 32, 64$ ) after offset adding is enabled. Take output gain into account when setting accumulation gain.

**(4) Delay Initialization Registers (CZp, CZs, DZp, DZs)**

Bit :	15	14	13	12	11	10	9	8	7	6	5	4	3	2	1	0
Initial value :	1	1	1	1	0	0	0	0	0	0	0	0	0	0	0	0
R/W :	—	—	—	—	W	W	W	W	W	W	W	W	W	W	W	W

The delay initialization register is a 16-bit write-only register. It accepts only a word-access. If a byte access is attempted, operation is not assured. If a read is attempted, an undefined value is read out. Bits 12 to 15 are reserved, and no write in them is valid.

It is initialized to H'F000 by a reset, stand-by or module stop. The MSB of 12-bit data (bit 11) is a sign bit.

Loading to  $Z^{-1}$  is performed automatically by bits 4 and 3 of CFIC and DFIC (CZPON, CZSON, DZPON, DZSON). Writing in register is always available, but loading in  $Z^{-1}$  is not possible when the digital filter is performing calculation processing in relation to such register. In such a case, loading to  $Z^{-1}$  will be done the next time computation begins.

**(5) Drum System Digital Filter Control Register (DFIC)**

Bit :	7	6	5	4	3	2	1	0
	—	DROV	DPHA	DZPON	DZSON	DSG2	DSG1	DSG0
Initial value :	1	0	0	0	0	0	0	0
R/W :	—	R/(W)*	R/(W)	R/W	R/W	R/W	R/W	R/W

Note: \* Only 0 can be written

DFIC is an 8-bit readable/writable register that controls the status of the drum system digital filter and operating mode. It can be accessed by byte access only. Word access gives unassured results. Bit 7 is a reserved bit. Writes are disabled. If read is attempted, an undetermined value is read out. DFIC is initialized to H'80 by a reset, and in standby mode and module stop mode.

**Bit 7—Reserved:** Reads and writes are both disabled.

**Bit 6—Drum System Range Over Flag (DROV):** This flag is set to 1 when the result of a drum system filter computation exceeds 12 bits in width. To clear this flag, write 0.

**Bit 6**

DROV	Description
0	Indicates that the filter computation result did not exceed 12 bits (Initial value)
1	Indicates that the filter computation result exceeded 12 bits

**Bit 5—Drum Phase System Filter Computation Start Bit (DPHA):** Starts or stops filter processing for the drum phase system.

**Bit 5**

DPHA	Description
0	Phase system filter computations are disabled Phase computation result (Y) is not added to Es (see figure 28.39) (Initial value)
1	Phase system filter computations are enabled

**Bit 4—Drum Phase System  $Z^{-1}$  Initialization Bit (DZPON):** Reflects the DZp value on  $Z^{-1}$  of the phase system when computation processing of the drum phase system begins. If 1 was written, it is reflected on the computation, and then cleared to 0. Set this bit after writing data to DZp.

**Bit 4**

DZPON	Description
0	DZp value is not reflected on $Z^{-1}$ of the phase system (Initial value)
1	DZp value is reflected on $Z^{-1}$ of the phase system

**Bit 3—Drum Speed System  $Z^{-1}$  Initialization Bit (DZSON):** Reflects the DZs value on  $Z^{-1}$  of the speed system when computation processing of the drum speed system begins. If 1 was written, it is reflected on the computation, and then cleared to 0. Set this bit after writing data to DZs.

**Bit 3**

DZSON	Description
0	DZs value is not reflected on $Z^{-1}$ of the speed system (Initial value)
1	DZs value is reflected on $Z^{-1}$ of the speed system

**Bits 2 to 0—Drum System Output Gain Control Bits (DSG2, DSG1, DSG0):** Control the gain output to DRMPWM.

Bit 2	Bit 1	Bit 0	Description
DSG2	DSG1	DSG0	
0	0	0	$\times 1$ (Initial value)
		1	$\times 2$
	1	0	$\times 4$
		1	$\times 8$
1	0	0	$\times 16$
		1	$(\times 32)^*$
	1	0	$(\times 64)^*$
		1	Invalid (Do not set)

Note: \* Setting optional

**(6) Capstan System Digital Filter Control Register (CFIC)**

Bit :	7	6	5	4	3	2	1	0
	—	CROV	CPHA	CZPON	CZSON	CSG2	CSG1	CSG0
Initial value :	1	0	0	0	0	0	0	0
R/W :	—	R/(W)*	R/(W)	R/W	R/W	R/W	R/W	R/W

Note: \* Only 0 can be written.

CFIC is an 8-bit readable/writable register that controls the status of the capstan system digital filter and operating mode. It can be accessed by byte access only. Word access gives unassured results.

Bit 7 is a reserved bit. Writes are disabled. If read is attempted, an undetermined value is read out. CFIC is initialized to H'80 by a reset, and in standby mode and module stop mode.

**Bit 7—Reserved:** Reads and writes are both disabled.

**Bit 6—Capstan System Range Over Flag (CROV):** This flag is set to 1 when the result of a capstan system filter computation exceeds 12 bits in width. To clear this flag, write 0.

**Bit 6**

CROV	Description
0	Indicates that the filter computation result did not exceed 12 bits (Initial value)
1	Indicates that the filter computation result exceeded 12 bits

**Bit 5—Capstan Phase System Filter Start Bit (CPHA):** Starts or stops filter processing for the capstan phase system.

**Bit 5**

CPHA	Description
0	Phase filter computations are disabled Phase computation result (Y) is not added to Es (see figure 28.39) (Initial value)
1	Phase filter computations are enabled

**Bit 4—Capstan Phase System  $Z^{-1}$  Initialization Bit (CZPON):** Reflects the CZp value on  $Z^{-1}$  of the capstan phase system when computation processing of the phase system begins. If 1 was written, it is reflected on the computation, and then cleared to 0. Set this bit after writing data to CZp.

**Bit 4**

CZPON	Description	
0	CZp value is not reflected on $Z^{-1}$ of the phase system	(Initial value)
1	CZp value is reflected on $Z^{-1}$ of the phase system	

**Bit 3—Capstan Speed System  $Z^{-1}$  Initialization Bit (CZSON):** Reflects the CZs value on  $Z^{-1}$  of the capstan speed system when computation processing of the speed system begins. If 1 was written, it is reflected on the computation, and then cleared to 0. Set this bit after writing data to CZs.

**Bit 3**

CZSON	Description	
0	CZs value is not reflected on $Z^{-1}$ of the speed system	(Initial value)
1	CZs value is reflected on $Z^{-1}$ of the speed system	

**Bits 2 to 0—Capstan System Gain Control Bits (CSG2, CSG1, CSG0):** Control the gain output to CAPPWM.

Bit 1	Bit 2	Bit 0	Description	
CSG2	CSG1	CSG0		
0	0	0	×1	(Initial value)
		1	×2	
	1	0	×4	
		1	×8	
1	0	0	×16	
		1	(×32)*	
	1	0	(×64)*	
		1	Invalid (Do not set)	

Note: \* Setting optional

**(7) Digital Filter Control Register (DFUCR)**

Bit :	7	6	5	4	3	2	1	0
	—	—	PTON	CP/DP	CFEPS	DFEPS	CFESS	DFESS
Initial value :	1	1	0	0	0	0	0	0
R/W :	—	—	R/W	R/W	R/W	R/W	R/W	R/W

DFUCR is an 8-bit readable/writable register which controls the operation of the digital filter. It accepts a byte-access only. If it was word-accessed, operation is not assured.

Bits 7 and 6 are reserved. No write in them is valid. It is initialized to H'00 by a reset, stand-by or module stop.

**Bits 7 and 6—Reserved:** No read or write is valid. If a read is attempted, an undefined value is read out.

**Bit 5—Phase System Computation Result PWM Output Bit (PTON):** Outputs the computation results of only the phase system to PWM. (The computation results of the drum phase system is output to the CAPPWM pin, and that of the capstan phase system is output to the DRMPWM pin.)

**Bit 5**

PTON	Description
0	Outputs the results of ordinary computation of the filter to PWM pin (Initial value)
1	Outputs the computation results of only the phase system to PWM pin

**Bit 4—PWM Output Selection Bit (CP/DP):** Selects whether the phase system computation results when PTON was set to 1 is output to the drum or capstan. The PWM of the selected side outputs ordinary filter computation results (speed system of MIX).

**Bit 4**

CP/DP	Description
0	Outputs the drum phase system computation results (CAPPWM) (Initial value)
1	Outputs the capstan phase system computation results (DRMPWM)

**Bit 3—Capstan Phase System Error Data Transfer Bit (CFEPS):** Transfers the capstan phase system error data to the digital filter when the data write is enforced.

**Bit 3**

CFEPS	Description
0	Error data is transferred by DVCFG2 signal latching (Initial value)
1	Error data is transferred when the data is written

**Bit 2—Drum Phase System Error Data Transfer Bit (DFEPS):** Transfers the drum phase system error data to the digital filter when the data write is enforced.

**Bit 2**

DFEPS	Description
0	Error data is transferred by HSW (NHSW) signal latching (Initial value)
1	Error data is transferred when the data is written

**Bit 1—Capstan Speed System Error Data Transfer Bit (CFESS):** Transfers the capstan speed system error data to the digital filter when the data write is enforced.

**Bit 1**

CFESS	Description
0	Error data is transferred by DVCFG signal latching (Initial value)
1	Error data is transferred when the data is written

**Bit 0—Drum Speed System Error Data Transfer Bit (DFESS):** Transfers the drum speed system error data to the digital filter when the data write is enforced.

**Bit 0**

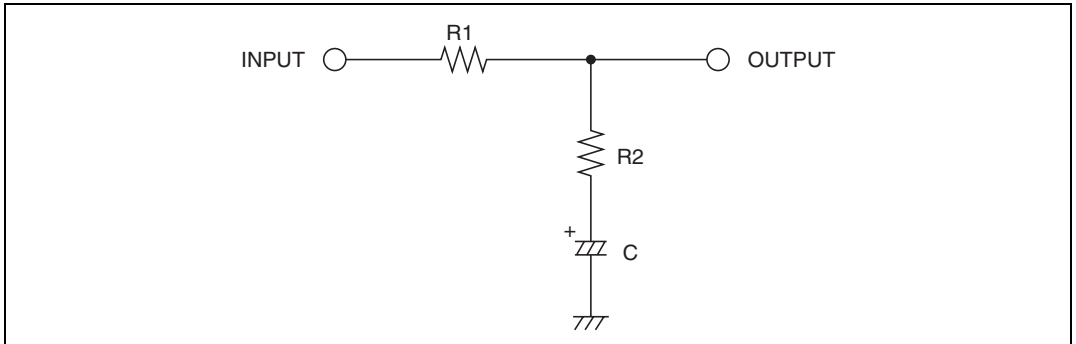
DFESS	Description
0	Error data is transferred by NCDG signal latching (Initial value)
1	Error data is transferred when the data is written



## 28.11.6 Filter Characteristics

### (1) Lag-Lead Filter

A filter required for a servo loop is built in the hardware. This filter uses an IIR (Infinite Impulse Response) type digital filter (another type of the digital filter is FIR, i.e. Finite Impulse Response type). This digital filter circuit implements a lag-lead filter, as shown in figure 28.40.



**Figure 28.40 Lag-Lead Filter**

The transfer function  $G(S)$  is expressed by the following equation.

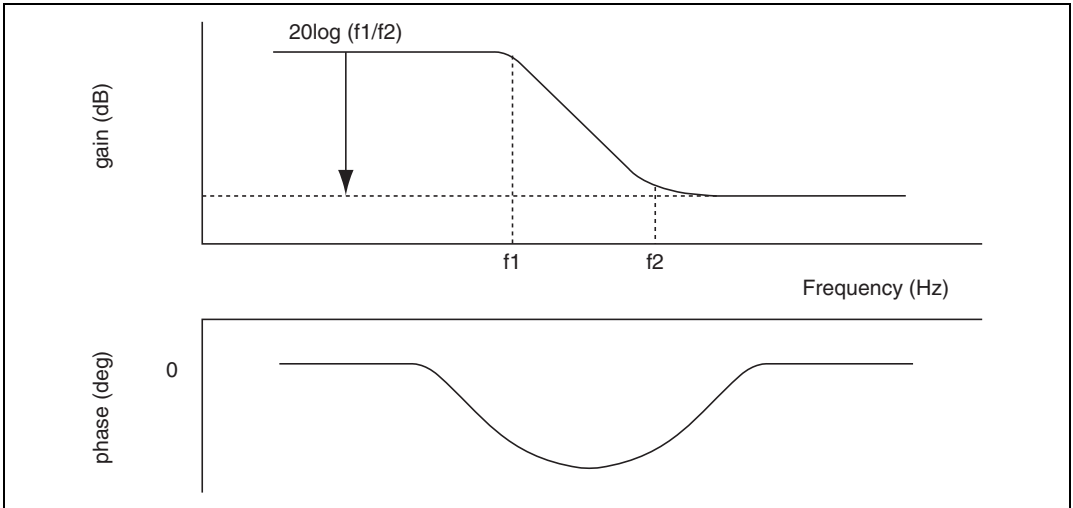
$$\text{Transfer function } G(S) = \frac{1 + \frac{S}{2\pi f_2}}{1 + \frac{S}{2\pi f_1}}$$

$$f_1 = 1/2\pi C (R1 + R2)$$

$$f_2 = 1/2\pi CR2$$

## (2) Frequency Characteristics

The computation circuit repeats computation of the function, which is obtained by s-z conversion according to bi-linear approximation of the transfer function on the s-plane. Figure 28.41 shows the frequency characteristics of the lag-lead filter.



**Figure 28.41 Frequency Characteristics of the Lag-Lead Filter**

The pulse transfer function  $G(Z)$  is obtained by the bi-linear approximation of the transfer function  $G(S)$ .

In the transfer  $G(S)$ ,

$$S = \frac{2}{T_s} \cdot \frac{1 - Z^{-1}}{1 + Z^{-1}}$$

Where, assumed that  $Z^{-1} = e^{-j\omega T_s}$ ,

$$G(Z) = G \cdot \frac{2}{T_s} \cdot \frac{1 + AZ^{-1}}{1 + BZ^{-1}}$$

$$G(Z) = \frac{T_s + \frac{1}{\pi f_2}}{T_s + \frac{1}{\pi f_1}} \quad A = \frac{T_s - \frac{1}{\pi f_2}}{T_s + \frac{1}{\pi f_2}} \quad B = \frac{T_s - \frac{1}{\pi f_1}}{T_s + \frac{1}{\pi f_1}}$$

$T_s$ : Sampling cycle (sec)

### 28.11.7 Operations in Case of Transient Response

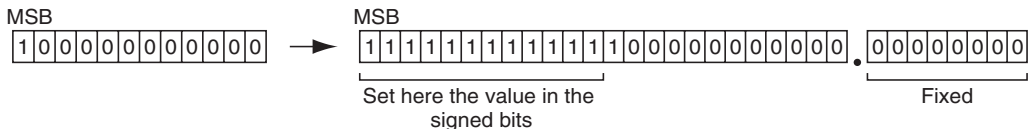
In case of transient response when the motor is activated, the digital filter computation circuit must prevent computation due to a large error. The convergence of the computations becomes slow and servo retraction becomes deteriorating if a large error is input to the filter circuit when it is performing repeated computations. To prevent them from occurring, operate the filter (set constants A and B) after pulling in the speed and phase within a certain range of error, initialize  $Z^{-1}$  (set initial values in CZp, CZs, DZp, DZs) (see section 28.11.8, Initialization of  $Z^{-1}$ ), or use the error data limit function (see section regarding the error detector).

### 28.11.8 Initialization of $Z^{-1}$

$Z^{-1}$  can be initialized by its delay initialization register (CZp, CZs, DZp, DZs). Loading to  $Z^{-1}$  is performed automatically by bits 4 and 3 of CFIC and DFIC (CZPON, CZSON, DZPON, DZSON). Writing in register is always available, but loading in  $Z^{-1}$  is not possible when the digital filter is performing calculation processing in relation to such register. In such a case, loading to  $Z^{-1}$  will be done the next time computation begins. Figure 28.42 shows the initialization circuit of  $Z^{-1}$ . The delay initialization register sets 12-bit data. The MSB (bit 11) is a signed bit.  $Z^{-1}$  has 24 bits for integers and 8 bits for decimals. Accordingly, the same value as the signed bits should be set in the 13 bits on the MSB side of  $Z^{-1}$ , and 0 in the entire decimal section.

Example: Value set for the delay initialization register

Value set for  $Z^{-1}$



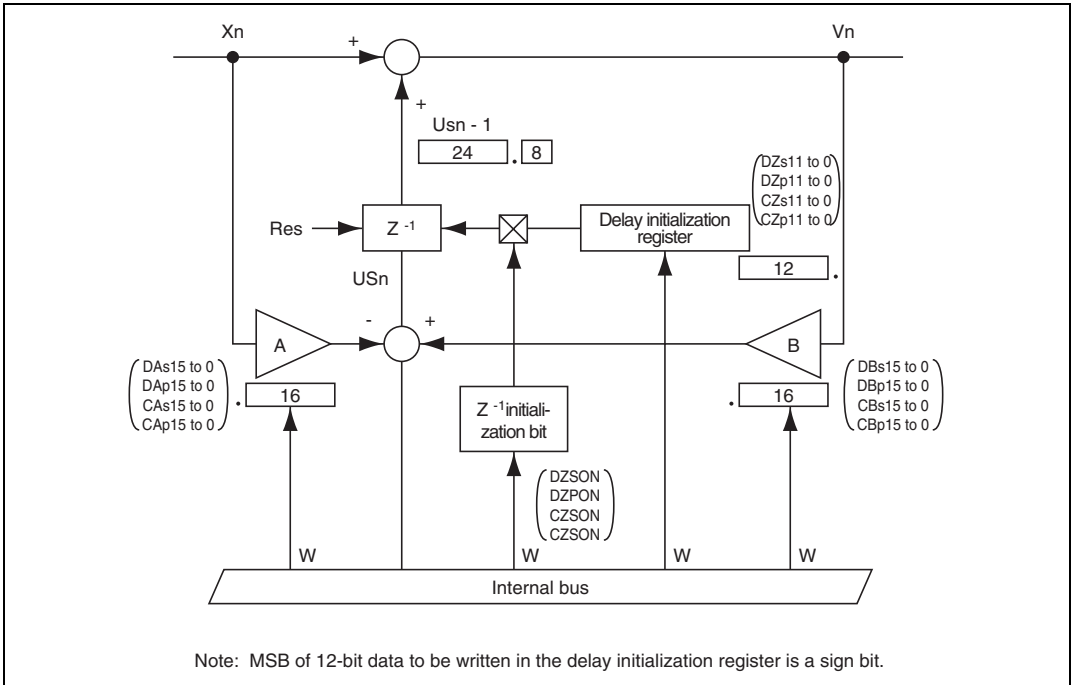


Figure 28.42  $Z^{-1}$  Initialization Circuit

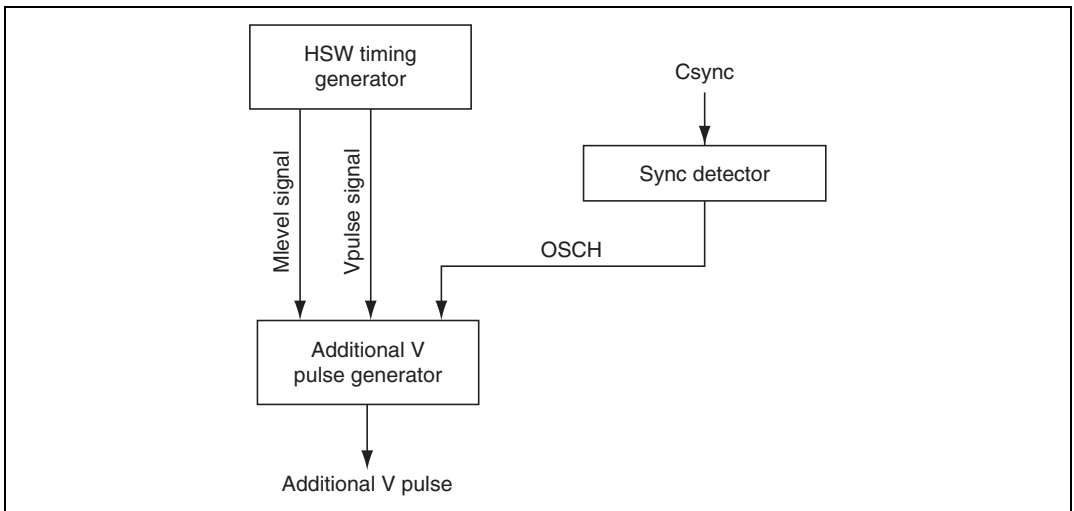
## 28.12 Additional V Signal Generator

### 28.12.1 Overview

The circuit described in this section outputs an additional vertical sync signal to take the place of Vsync in special playback. It is activated at both edges of the HSW signal output by the head-switch timing generator. The head-switch timing generator also outputs a Vpulse signal containing the additional vertical sync pulse itself, and an Mlevel signal that defines the width of the additional vertical sync signal including the equalizing pulses.

The additional V signal is output at a three-level output pin (Vpulse).

Figure 28.43 shows the additional V signal control circuit.



**Figure 28.43 Additional V Pulse Control Circuit**

**HSW Timing Generator:** This circuit generates signals that are synchronized with head switching. It should be programmed to generate the Mlevel and Vpulse signals at edges of the HSW signal (VideoFF). For details, see section 28.4, HSW (Head-switch) Timing Generator.

**Sync Detector:** This circuit detects pulses of the width specified by VTR or HTR from the signal input at the Csync pin and generates an internal horizontal sync signal (OSCH). The sync detector has an interpolation function, so OSCH has a regular period even if there are horizontal sync dropouts in the signal received at the pin. For details, see section 28.15, Sync Signal Detector.

### 28.12.2 Pin Configuration

Table 28.16 summarizes the pin configuration of the additional V signal.

**Table 28.16 Pin Configuration**

Name	Abbrev.	I/O	Function
Additional V pulse pin	Vpulse	Output	Output of additional V signal synchronized to VideoFF

### 28.12.3 Register Configuration

Table 28.17 summarizes the register that controls the additional V signal.

**Table 28.17 Register Configuration**

Name	Abbrev.	R/W	Size	Initial Value	Address
Additional V control register	ADDVR	R/W	Byte	H'E0	H'FD06F

### 28.12.4 Register Description

Additional V Control Register (ADDVR)

Bit :	7	6	5	4	3	2	1	0
	—	—	—	HMSK	Hi-Z	CUT	VPON	POL
Initial value :	1	1	1	0	0	0	0	0
R/W :	—	—	—	R/W	R/W	R/W	R/W	R/W

ADDVR is an 8-bit readable/writable register. It is initialized to H'E0 by a reset, and in standby mode.

**Bits 7 to 5—Reserved:** Writes are disabled. If a read is attempted, an undefined value is read out.

**Bit 4—OSCH Mask Bit (HMSK):** Masks the OSCH signal in the additional V pulse.

#### Bit 4

HMSK	Description
0	OSCH is added in (Initial value)
1	OSCH is not added in

**Bit 3—High Impedance Bit (Hi-Z):** Set to 1 when the intermediate level is generated by an external circuit.

**Bit 3**

Hi-Z	Description
0	Vpulse is a three-level output pin (Initial value)
1	Vpulse is a three-state output pin (high, low, or high-impedance)

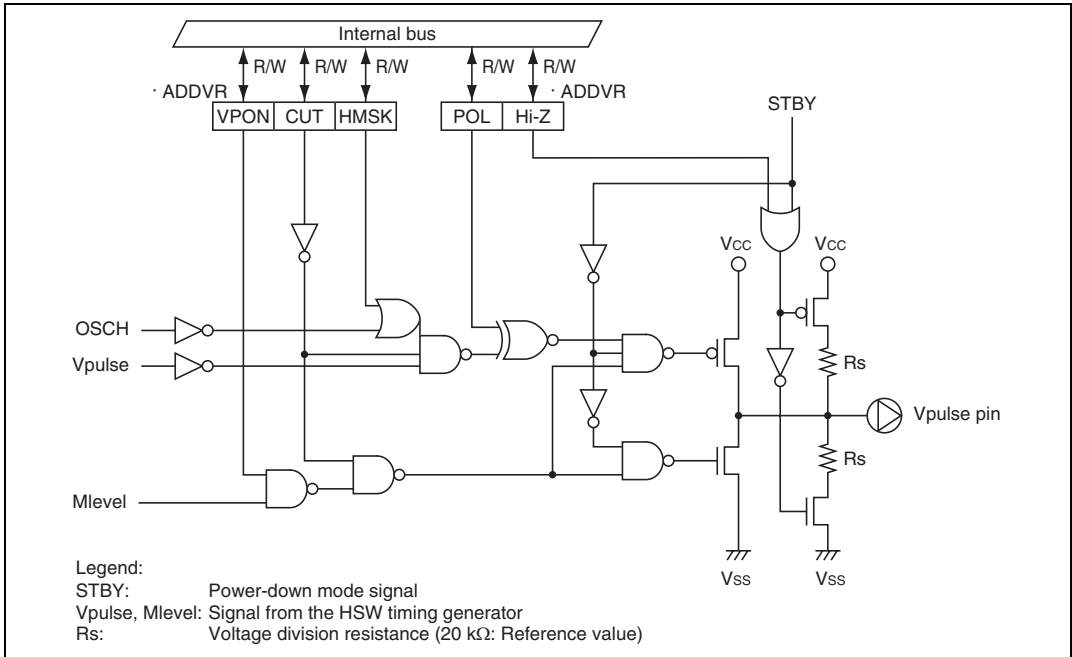
**Bits 2 to 0—Additional V Output Control Bit (CUT, VPON, POL):** These bits control the output at the additional V pin.

Bit 2	Bit 1	Bit 0	Description
CUT	VPON	POL	
0	0	*	Low level (Initial value)
		0	Negative polarity (see figure 28.46)
	1	Positive polarity (see figure 28.45)	
1	*	0	Intermediate level (high impedance if Hi-Z bit = 1)
		1	High level

Legend: \* Don't care.

### 28.12.5 Additional V Pulse Signal

Figure 28.44 shows the additional V pulse signal. The Mlevel and Vpulse signals are generated by the head-switch timing generator. The OSCH signal is combined with these to produce equalizing pulses. The polarity can be selected by the POL bit in the additional V register (ADDVR). The Vpulse pin outputs a low level by a reset, and in standby mode and module stop mode.



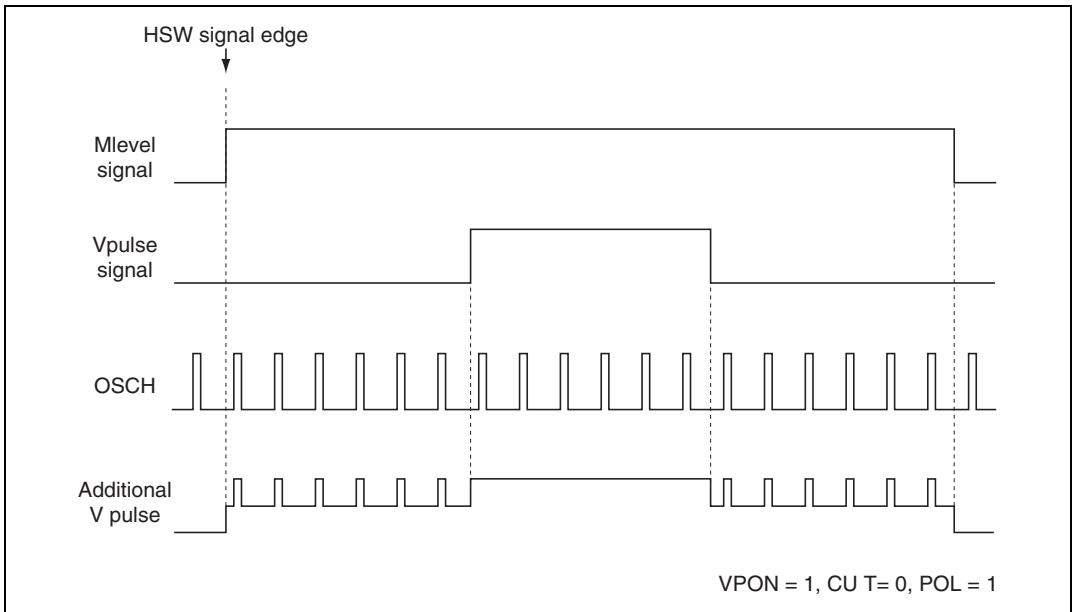
**Figure 28.44 Additional V Pin**

**Additional V Pulses when Sync Signal Is Not Detected:** With additional V pulses, the pulse signal (OSCH) detected by the sync detector is superimposed on the Vpulse and Mlevel signals generated by the head-switch timing generator. If there is a lot of noise in the input sync signal (Csync), or a pulse is missing, OSCH will be a complementary pulse, and therefore an H pulse of the period set in HRTR and HPWR will be superimposed. In this case, there may be slight timing drift compared with the normal sync signal, depending on the HRTR and HPWR setting, with resultant discontinuity.

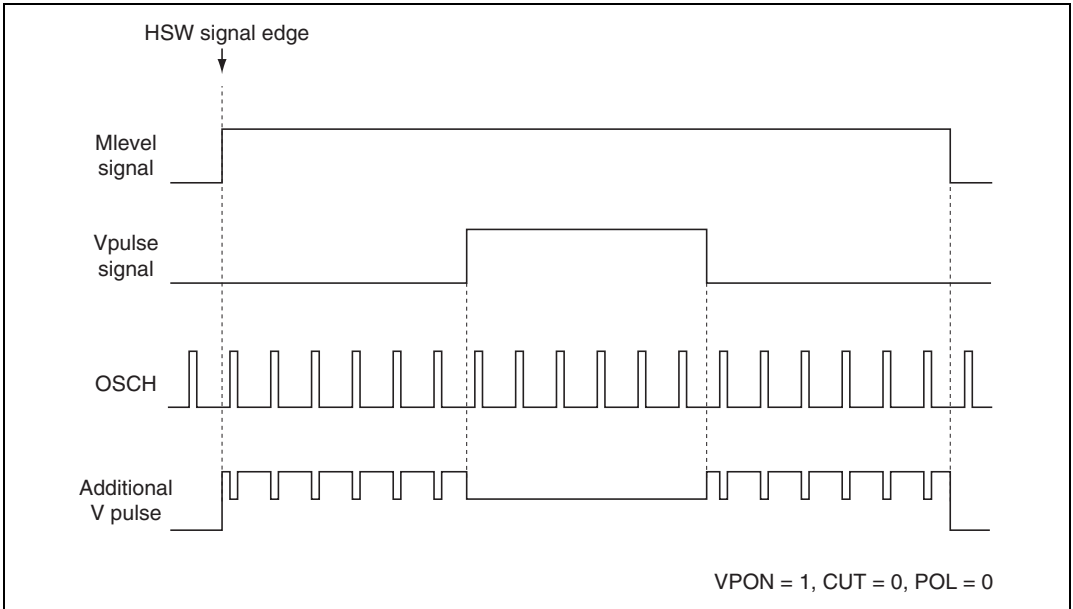
If no sync signal is input, the additional V pulse is generated as a complementary pulse. Set the sync detector registers and activate the sync detector by manipulating the SYCT bit in the sync signal control register (SYNCR). See section 28.15.7, Sync Signal Detector Activation.



Figures 28.45 and 28.46 show the additional V pulse timing charts.



**Figure 28.45 Additional V Pulse when Positive Polarity Is Specified**



**Figure 28.46 Additional V Pulse when Negative Polarity Is Specified**

## 28.13 CTL Circuit

### 28.13.1 Overview

The CTL circuit includes a Schmitt amplifier that amplifies and reshapes the CTL input, then outputs it as the PB-CTL signal to the servo, linear time counter, and other circuits.

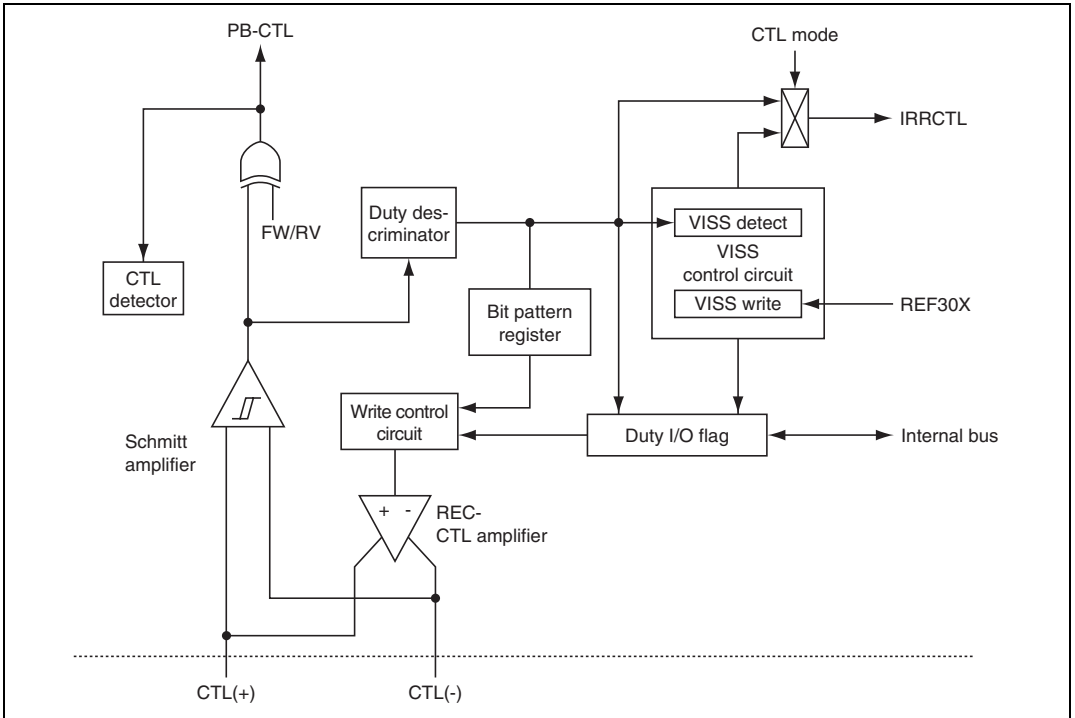
The PB-CTL signal is also sent to a duty discriminator in the CTL circuit that detects and records VISS, ASM, and VASS marks. A REC-CTL amplifier is included in the record circuits. Detection and recording whether the CTL pulse pattern is long or short can also be enabled to correspond to the wide-aspect.

The following operating modes can be selected by settings in the CTL mode register:

- Duty discrimination  
VISS detect, ASM detect, VASS detect, L/S bit pattern detect
- CTL record  
VISS record, ASM record, VASS record, L/S bit pattern detect
- Rewrite  
Trapezoid waveform generator

### 28.13.2 Block Diagram

Figure 28.47 shows a block diagram of the CTL circuit.



**Figure 28.47 Block Diagram of CTL Circuit**

### 28.13.3 Pin Configuration

Table 28.18 summarizes the pin configuration of the CTL circuit.

**Table 28.18 Pin Configuration**

Name	Abbrev.	I/O	Function
CTL (+) I/O pin	CTL (+)	I/O	CTL signal input/output
CTL (-) I/O pin	CTL (-)	I/O	CTL signal input/output
CTL Bias input pin	CTL Bias	Input	CTL primary amplifier bias supply
CTL Amp (O) output pin	CTLAmp (O)	Output	CTL amplifier output
CTL SMT (i) input pin	CTLSMT (i)	Input	CTL Schmitt amplifier input
CTL FB input pin	CTL FB	Input	CTL amplifier high-range characteristics control
CTL REF output pin	CTL REF	Output	CTL amplifier reference voltage output

### 28.13.4 Register Configuration

Table 28.19 shows the register configuration of the CTL circuit.

**Table 28.19 Register Configuration**

Name	Abbrev.	R/W	Size	Initial Value	Address
CTL control register	CTCR	R/W	Byte	H'30	H'FD080
CTL mode register	CTLM	R/W	Byte	H'00	H'FD081
REC-CTL duty data register 1	RCDR1	W	Word	H'F000	H'FD082
REC-CTL duty data register 2	RCDR2	W	Word	H'F000	H'FD084
REC-CTL duty data register 3	RCDR3	W	Word	H'F000	H'FD086
REC-CTL duty data register 4	RCDR4	W	Word	H'F000	H'FD088
REC-CTL duty data register 5	RCDR5	W	Word	H'F000	H'FD08A
Duty I/O register	DI/O	R/W	Byte	H'F1	H'FD08C
Bit pattern register	BTPR	R/W	Byte	H'FF	H'FD08D

### 28.13.5 Register Descriptions

#### (1) CTL Control Register (CTCR)

Bit :	7	6	5	4	3	2	1	0
	NT/PL	FSLC	FSLB	FSLA	CCS	LCTL	UNCTL	SLWM
Initial value :	0	0	1	1	0	0	0	0
R/W :	W	W	W	W	W	W	R	W

The CTL control register (CTCR) controls PB-CTL rewrite and sets the slow mode. When a CTL pulse cannot be detected with the input amplifier gain set at the CTL gain control register (CTLGR) in the PB-CTL circuit, bit 1 (UNCTL) of CTCR is set to 1. It is automatically cleared to 0 when a CTL pulse is detected.

CTCR is an 8-bit readable/writable register. However, bit 1 is read-only, and the rest is write-only. CTCR is initialized to H'30 by a reset, and in standby and module stop mode.

**Bit 7—NTSC/PAL Selection Bit (NT/PL):** Selects the period of the rewrite circuit.

#### Bit 7

NT/PL	Description
0	NTSC mode (frame rate: 30 Hz) (Initial value)
1	PAL mode (frame rate: 25 Hz)

**Bits 6 to 4—Frequency Selection Bits (FSLA, FSLB, FSLC):** These bits select the operating frequency of the CTL rewrite circuit. They should be set according to fosc.

Bit 6	Bit 5	Bit 4	Description
FSLC	FSLB	FSLA	
0	0	0	Reserved (do not set)
		1	Reserved (do not set)
	1	0	fosc = 8 MHz
		1	fosc = 10 MHz (Initial value)
1	*	*	Reserved (do not set)

Legend: \* Don't care.

**Bits 3—Clock Source Selection Bit (CCS):** Selects clock source of CTL.

**Bit 3**

CCS	Description
0	$\phi_s$ (Initial value)
1	$\phi_s/2$

**Bit 2—Long CTL Bit (LCTL):** Sets the long CTL detection mode.

**Bit 2**

LCTL	Description
0	Clock source (CCS) operates at the setting value (Initial value)
1	Clock source (CCS) operates for further 8-division after operating at the setting value

**Bit 1—CTL Undetected Bit (UNCTL):** Indicates the CTL pulse detection status at the CTL input amplifier sensitivity set at the CTL gain control register (CTLGR).

**Bit 1**

UNCTL	Description
0	Detected (Initial value)
1	Undetected

**Bit 0—Mode Selection Bit (SLWM):** Selects CTL mode.

**Bit 0**

SLWM	Description
0	Normal mode (Initial value)
1	Slow mode

**(2) CTL Mode Register (CTLM)**

Bit :	7	6	5	4	3	2	1	0
	ASM	REC/ $\overline{\text{PB}}$	FW/RV	MD4	MD3	MD2	MD1	MD0
Initial value :	0	0	0	0	0	0	0	0
R/W :	R/W	R/W	R/W	R/W	R/W	R/W	R/W	R/W

The CTL mode register (CTLM) is an 8-bit readable/writable register that controls the operating state of the CTL circuit. If 1 is written in bits MD3 and MD2, they will be cleared to 0 one cycle ( $\phi$ ) later.

CTLM is initialized to H'00 by a reset, and in standby mode and module stop mode. When CTL is being stopped, only bits 7, 6, and 5 operate.

Note: Do not set any value other than the setting value for each mode (see table 28.20).

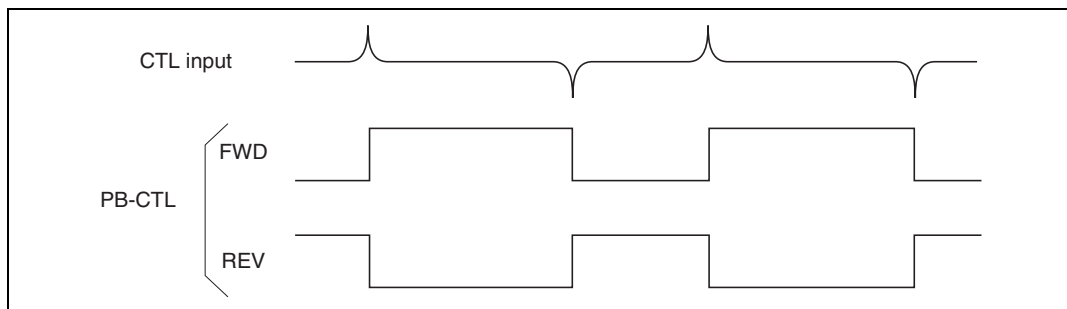
**Bits 7 and 6—Record/Playback Mode Bits (ASM, REC/ $\overline{\text{PB}}$ ):** These bits switch between record and playback. Combined with bits 4 to 0 (MD4 to MD0), they support the VISS, VASS, and ASM mark functions.

Bit 7	Bit 6	Description
ASM	REC/ $\overline{\text{PB}}$	
0	0	Playback mode (Initial value)
	1	Record mode
1	0	Assemble mode
	1	Invalid (do not set)

**Bit 5—Direction Bit (FW/RV):** Selects the direction in playback. Clear this bit to 0 during record. Figure 28.48 shows the PB-CTL signal in forward and reverse.

Bit 5	Description
FW/RV	
0	FORWARD (Initial value)
1	REVERSE





**Figure 28.48 Internal PB-CTL Signal in Forward and Reverse**

**Bits 4 to 0—CTL Mode Selection Bits (MD4 to MD0):** These bits select the detect, record, and rewrite modes for VISS, VASS, and ASM marks. If 1 is written in bits MD3 and MD2, they will be cleared to 0 one cycle ( $\phi$ ) later.

The 5 bits from MD4 to MD0 are used in combination with bits 7 and 6 (ASM and REC/ $\overline{\text{PB}}$ ). Table 28.20 describes the modes.

**Table 28.20 CTL Mode Functions**

Bit									
ASM	REC/ $\overline{\text{PB}}$	FW/ RV	MD4	MD3	MD2	MD1	MD0	Mode	Description
0	0	0/1	0	0	0	0	0	VASS detect (duty detect)	PB-CTL duty discrimination (Initial value) <ul style="list-style-type: none"> <li>• Duty I/O flag is set to 1 if duty <math>\geq</math> 44% is detected</li> <li>• Duty I/O flag is cleared to 0 if duty &lt; 44% is detected</li> <li>• Interrupt request is generated when one CTL pulse has been detected</li> </ul>
0	1	0	0	0	0	0	0	VASS record	<ul style="list-style-type: none"> <li>• If 0 is written in the duty I/O flag, REC-CTL is generated and recorded with the duty cycle set by register RCDR2 or RCDR3</li> <li>• If 1 is written in the duty I/O flag, REC-CTL is generated and recorded with the duty cycle set by register RCDR4 or RCDR5</li> </ul>
0	0	0	1	0	0	1	0	VASS rewrite	Same as above (VASS record; trapezoid waveform circuit operation)

## Bit

ASM	REC/ PB	FW/RV	MD4	MD3	MD2	MD1	MD0	Mode	Description
0	0	0/1	0	1	0	0	1	VISS detect (index detect)	<p>The duty I/O flag is set to 1 at the point of write access to register CTLM</p> <ul style="list-style-type: none"> <li>The 1 pulses recognized by the duty discrimination circuit are counted in the VISS control circuit</li> <li>The duty I/O flag is cleared to 0, indicating VISS detection, when the value set at VCTR register is repeatedly detected</li> <li>An interrupt request is generated when VISS is detected</li> </ul>
0	1	0	0	0	1	0	1	VISS record (index record)	<ul style="list-style-type: none"> <li>64 pulse data with 0 pulse data at both edges are written (index record)</li> <li>The index bit string is written through the duty I/O flag</li> <li>An interrupt request is generated at the end of VISS recording</li> </ul>
0	0	0	0	0	1	0	1	VISS rewrite	Same as above (VISS record; trapezoid waveform circuit operation)
0	0	0	1	0	0	0	0	VISS initialize	VISS write is forcibly aborted
1	0	0/1	0	0	0	0	0	ASM mark detect	<p>ASM mark detection</p> <ul style="list-style-type: none"> <li>The duty I/O flag is cleared to 0 when PB-CTL duty <math>\geq 66\%</math> is detected</li> <li>An interrupt request is generated when an ASM mark is detected</li> </ul>
0	1	0	1	0	0	0	0	ASM mark record	<ul style="list-style-type: none"> <li>An ASM mark is recorded by writing 0 in the duty I/O flag</li> <li>An interrupt is requested for every one CTL pulse</li> <li>REC-CTL is generated and recorded with the duty cycle set by register RCDR3</li> </ul>

**(3) REC-CTL Duty Data Register 1 (RCDR1)**

Bit :	15	14	13	12	11	10	9	8	7	6	5	4	3	2	1	0
	—	—	—	—	CMT1B	CMT1A	CMT19	CMT18	CMT17	CMT16	CMT15	CMT14	CMT13	CMT12	CMT11	CMT10
Initial value :	1	1	1	1	0	0	0	0	0	0	0	0	0	0	0	0
R/W :	—	—	—	—	W	W	W	W	W	W	W	W	W	W	W	W

RCDR1 is a register that sets the REC-CTL rising timing. This setting is valid only for recording and rewriting, and is not used in detection.

RCDR1 is a 12-bit write-only register, and can be accessed by word access only. Byte access gives unassured results. If read is attempted, an undetermined value is read out. Bits 15 to 12 are reserved and are not affected by write access.

RCDR1 is initialized to H'F000 by a reset, and in standby mode, module stop mode and CTL stop mode.

The value to set in RCDR1 can be calculated from the transition timing T1 and the servo clock frequency  $\phi_s$  by the equation given below. See figure 28.60. Any transition timing can be set. However, the timing should be selected with attention to playback tracking compensation and the latch timing for phase control.

$$\text{RCDR1} = T1 \times \phi_s / 64$$

$\phi_s$  is the servo clock frequency ( $= f_{\text{osc}}/2$ ) in Hz, and T1 is the set timing (s).

Note: 0 cannot be set to RCDR1. Set a value 1 or above.

**(4) REC-CTL Duty Data Register 2 (RCDR2)**

Bit :	15	14	13	12	11	10	9	8	7	6	5	4	3	2	1	0
	—	—	—	—	CMT2B	CMT2A	CMT29	CMT28	CMT27	CMT26	CMT25	CMT24	CMT23	CMT22	CMT21	CMT20
Initial value :	1	1	1	1	0	0	0	0	0	0	0	0	0	0	0	0
R/W :	—	—	—	—	W	W	W	W	W	W	W	W	W	W	W	W

RCDR2 is a register that sets 1 pulse (short) falling timing of REC-CTL at recording and rewriting, and detects long/short pulses at detecting.

RCDR2 is a 12-bit write-only register, and can be accessed by word access only. Byte access gives unassured results. If read is attempted, an undetermined value is read out. Bits 15 to 12 are reserved and are not affected by write access.

RCDR2 is initialized to H'F000 by a reset, and in standby mode, module stop mode, and CTL stop mode.

At recording, the value to set in RCDR2 can be calculated from the transition timing T2 and the servo clock frequency  $\phi_s$  by the equation given below, and the set value should be 25% of the duty obtained by the equation. See figure 28.60.

$$\text{RCDR2} = T2 \times \phi / 64$$

$\phi$ s is the servo clock frequency ( $= f_{\text{osc}}/2$ ) in Hz, and T2 is the set timing (s).

At bit pattern detection, set the 1 pulse long/short threshold value at FWD. See figure 28.56.

$$\text{RCDR2} = T2' \times \phi / 64$$

$\phi$ s is the servo clock frequency ( $= f_{\text{osc}}/2$ ) in Hz, and T2' is the 1 pulse long/short threshold value at FWD (s).

### (5) REC-CTL Duty Data Register 3 (RCDR3)

Bit :	15	14	13	12	11	10	9	8	7	6	5	4	3	2	1	0
	—	—	—	—	CMT3B	CMT3A	CMT39	CMT38	CMT37	CMT36	CMT35	CMT34	CMT33	CMT32	CMT31	CMT30
Initial value :	1	1	1	1	0	0	0	0	0	0	0	0	0	0	0	0
R/W :	—	—	—	—	W	W	W	W	W	W	W	W	W	W	W	W

RCDR3 is a register that sets 1 pulse (long) and assemble mark falling timing of REC-CTL at recording and rewriting, and detects long/short pulses at detecting.

RCDR3 is a 12-bit write-only register, and can be accessed by word access only. Byte access gives unassured results. If read is attempted, an undetermined value is read out. Bits 15 to 12 are reserved and are not affected by write access.

RCDR3 is initialized to H'F000 by a reset, and in standby mode, module stop mode, and CTL stop mode.

At recording, the value to set in RCDR3 can be calculated from the transition timing T3 and the servo clock frequency  $\phi$ s by the equation given below. The set value should be 30% of the duty when the RCDR3 is used for REC-CTL 1 pulse (long), and 67% to 70% when used for assemble mark. The set value must not exceed the value of REF30X. See figure 28.60.

$$\text{RCDR3} = T3 \times \phi / 64$$

$\phi$ s is the servo clock frequency ( $= f_{\text{osc}}/2$ ) in Hz, and T3 is the set timing (s).

At bit pattern detection, set the 0 pulse long/short threshold value at FWD. See figure 28.56.

$$\text{RCDR3} = T3' \times \phi / 64$$

$\phi$ s is the servo clock frequency ( $= f_{\text{osc}}/2$ ) in Hz, and T3' is the 0 pulse long/short threshold value at FWD (s).

**(6) REC-CTL Duty Data Register 4 (RCDR4)**

Bit :	15	14	13	12	11	10	9	8	7	6	5	4	3	2	1	0
	—	—	—	—	CMT4B	CMT4A	CMT49	CMT48	CMT47	CMT46	CMT45	CMT44	CMT43	CMT42	CMT41	CMT40
Initial value :	1	1	1	1	0	0	0	0	0	0	0	0	0	0	0	0
R/W :	—	—	—	—	W	W	W	W	W	W	W	W	W	W	W	W

RCDR4 sets the timing of falling edge of the 0 pulse (short) of REC-CTL in record or rewrite mode. In detection mode, it is used to detect the long/short pulse.

RCDR4 is a 12-bit write-only register. It accepts only a word-access. If a byte access is attempted, operation is not assured. If a read is attempted, an undefined value is read out. Bits 15 to 12 are reserved, and no write in them is valid.

It is initialized to H'F000 by a reset, stand-by, module stop or CTL stop.

In record mode, set a value with the 57.5% duty cycle obtained from the transition timing T4 corresponding to the servo clock frequency  $\phi_s$  according to the following equation. See figure 28.60.

$$RCDR4 = T4 \times \phi_s / 64$$

$\phi_s$  is the servo clock frequency ( $= f_{osc}/2$ ) in Hz, and T4 is the set timing (s).

At bit pattern detection, set the 0 pulse long/short threshold value at REV. See figure 28.56.

$$RCDR4 = H'FFF - (T4' \times \phi_s / 80)$$

$\phi_s$  is the servo clock frequency ( $= f_{osc}/2$ ) in Hz, and T4' is the 0 pulse long/short threshold value at REV (s).

**(7) REC-CTL Duty Data Register 5 (RCDR5)**

Bit :	15	14	13	12	11	10	9	8	7	6	5	4	3	2	1	0
	—	—	—	—	CMT5B	CMT5A	CMT59	CMT58	CMT57	CMT56	CMT55	CMT54	CMT53	CMT52	CMT51	CMT50
Initial value :	1	1	1	1	0	0	0	0	0	0	0	0	0	0	0	0
R/W :	—	—	—	—	W	W	W	W	W	W	W	W	W	W	W	W

RCDR5 sets the timing of falling edge of the 0 pulse (long) of REC-CTL in record or rewrite mode. In detection mode, it is used to detect the long/short pulse.

RCDR5 is a 12-bit write-only register. It accepts only a word-access. If a byte access is attempted, operation is not assured. If a read is attempted, an undefined value is read out. Bits 15 to 12 are reserved, and no write in them is valid.

It is initialized to H'F000 by a reset, stand-by, module stop or CTL stop.

In record mode, set a value with the 62.5% duty cycle obtained from the transition timing T5 corresponding to the servo clock frequency  $\phi_s$  according to the following equation. See figure 28.60.

$$RCDR5 = T5 \times \phi / 64$$

$\phi$ s is the servo clock frequency ( $= f_{osc}/2$ ) in Hz, and T5 is the set timing (s).

At bit pattern detection, set the 1 pulse long/short threshold value at REV. See figure 28.56.

$$RCDR5 = H'FFF - (T5' \times \phi / 80)$$

$\phi$ s is the servo clock frequency ( $= f_{osc}/2$ ) in Hz, and T5' is the 1 pulse long/short threshold value at REV (s).

### (8) Duty I/O Register (DI/O)

Bit :	7	6	5	4	3	2	1	0
	VCTR2	VCTR1	VCTR0	—	BPON	BPS	BPF	DI/O
Initial value :	1	1	1	1	0	0	0	1
R/W :	W	W	W	—	W	W	R/(W)*	R/W

Note: \* Only 0 can be written.

The duty I/O register is an 8-bit register that confirms and determines the operating status of the CTL circuit.

It is initialized to H'F1 by a reset, and in standby mode, module stop mode, and CTL stop mode.

**Bits 7, 6, and 5—VISS Interrupt Setting Bits (VCTR2, VCTR1, VCTR0):** Combination of VCTR2, VCTR1, and VCTR0 sets number of 1 pulse detection in VISS detection mode. Detecting the set number of pulse detection is considered as VISS detection, and an interrupt request is generated.

Note: When changing the detection pulse number during VISS detection, initialize VISS first, then resume the VISS detection setting.

Bit 7	Bit 6	Bit 5	
VCTR2	VCTR1	VCTR0	Number of 1-Pulse for Detection
0	0	0	2
		1	4 (SYNC mark)
	1	0	6
		1	8 (mark A, short)
1	0	0	12 (mark A, long)
		1	16
	1	0	24 (mark B)
		1	32

**Bit 4—Reserved:** Writes are disabled. When read, undefined values are obtained.

**Bit 3—Bit Pattern Detection ON/OFF Bit (BPON):** Determines ON or OFF of bit pattern detection.

Note: When writing 1 to the BPON bit, be sure to set appropriate data to RCDR2 to RCDR5 beforehand.

### Bit 3

BPON	Description
0	Bit pattern detection OFF (Initial value)
1	Bit pattern detection ON

**Bit 2—Bit Pattern Detection Start Bit (BPS):** Starts 8-bit bit pattern detection. When 1 is written to this bit, it returns to 0 after one cycle. Writing 0 to this bit does not affect operation.

### Bit 2

BPS	Description
0	Normal status (Initial value)
1	Starts 8-bit bit pattern detection

**Bit 1—Bit Pattern Detection Flag (BPF):** Sets the flag every time 8-bit PB-CTL is detected in PB or ASM mode. To clear the flag, write 0 after reading 1.

### Bit 1

BPF	Description
0	Bit pattern (8-bit) is not detected (Initial value)
1	Bit pattern (8-bit) is detected

**Bit 0—Duty I/O Register (DI/O):** This flag has different functions for record and playback. In VISS detect mode, VASS detect mode, and ASM mark detect mode, this flag indicates the detection result.

In VISS record or rewrite mode, this flag controls the write control circuit so as to write an index code, operating according to a control signal from the VISS control circuit.

In VISS record or rewrite mode and ASM mark record mode, this flag is used for write control, one CTL pulse at a time.

This bit can always be written to, but this does not affect the write control circuit in modes other than VISS record or rewrite, and ASM record.

**VISS Detect Mode and VASS Detect Mode:**

The duty I/O flag indicates the result of duty discrimination. The duty I/O flag is 1 when the duty cycle of the PB-CTL signal is equal to or above 44% (a 0 pulse in the CTL signal). The duty I/O flag is 0 when the duty cycle of the PB-CTL signal is below 43% (a 1 pulse in the CTL signal).

**ASM Mark Detect Mode:**

The duty I/O flag indicates the result of duty discrimination. The duty I/O flag is 0 when the duty cycle of the PB-CTL signal is equal to or above 66% (when an ASM mark is detected).

The duty I/O flag is 1 when the duty cycle of the PB-CTL signal is below 65% (when an ASM mark is not detected).

**VISS Record Mode and VISS Rewrite Mode:**

The duty I/O flag operates according to a control signal from the VISS control circuit, and controls the write control circuit so as to write an index code. The write timing is set in the REC-CTL duty data registers (RCDR1 to RCDR5). For VISS recording, registers RCDR1 to RCDR5 are set with reference to REF30X. For VISS rewrite, registers RCDR2 to RCDR5 are set with reference to the low-to-high transition of the previously recorded CTL signal, and the write is carried out through the trapezoid waveform generator.

Set the duty timing for a 1 pulse (short) in RCDR2, for a 1 pulse (long) in RCDR3, for a 0 pulse (short) in RCDR4, and for a 0 pulse (long) in RCDR5.

While an index code is being written, the value of the bit being written can be read by reading the duty I/O flag. If the CTL signal currently being written is a 0 pulse, the duty I/O flag will read 1. If the CTL signal currently being written is a 1 pulse, the duty I/O flag will read 0.

**VASS Record Mode and VASS Rewrite Mode:**

The duty I/O flag is used for write control, one CTL pulse at a time. The write timing is set in the REC-CTL duty data registers (RCDR1 to RCDR5). For VASS recording, registers RCDR1 to RCDR5 are set with reference to REF30X. For VASS rewrite, registers RCDR2 to RCDR5 are set with reference to the low-to-high transition of the previously recorded CTL signal, and the write is carried out through the trapezoid waveform generator.

Set the duty timing for a 1 pulse (short) in RCDR2, for a 1 pulse (long) in RCDR3, for a 0 pulse (short) in RCDR4, and for a 0 pulse (long) in RCDR5.

If 0 is written in the duty I/O flag, a CTL pulse will be written with a duty cycle set in RCDR2 and RCDR3, referenced to the immediately following REF30X. If 1 is written in the duty I/O flag, a CTL pulse will be written with a duty cycle set in RCDR4 and RCDR5, referenced to the immediately following REF30X.

**ASM Record Mode:**

The duty I/O flag is used for write control, one CTL pulse at a time. The write timing is set in the REC-CTL duty data registers (RCDR1 and RCDR3). If 0 is written in the duty I/O flag, a CTL



pulse will be written with a duty cycle of 67% to 70% as set in RCDR3, referenced to the immediately following REF30X.

### (9) Bit Pattern Register (BTPR)

Bit :	7	6	5	4	3	2	1	0
	LSP7	LSP6	LSP5	LSP4	LSP3	LSP2	LSP1	LSP0
Initial value :	1	1	1	1	1	1	1	1
R/W :	R/W*	R/W*	R/W*	R/W*	R/W*	R/W*	R/W*	R/W*

Note: \* Write is prohibited when bit pattern detection is selected.

The bit pattern register (BTPR) is an 8-bit shift register which detects and records the bit pattern of the CTL pulses. If a CTL pulse is detected in PB or ASM mode, the register is shifted leftward at the rising edge of PB-CTL, and reflects the determined result of long/short on bit 0 (long pulse = 1, short pulse = 0).

If the BPON bit is set to 1 in PB mode, the register starts detection of bit pattern immediately after the CTL pulse. To exit the bit pattern detection, set the BPON bit at 0.

If 1 was written in the BPS bit when the bit pattern is being detected, the BPF bit is set at 1 when an 8-bit bit pattern was detected. If continuous detection of 8-bits is required, write 0 in the BPF bit, and then write 1 in the BPS bit.

At the time of VISS detection, the bit pattern detection is disabled. Set the BPON bit to 0 at the time of VISS detection.

In REC mode, the register records the long/short in the bit pattern set in BTPR. The pulse in record mode is determined always by bit 7 (LSP7) of BTPR. BTPR records one pulse, shifts leftward, and stores the data of bit 7 to bit 0.

BTPR is initialized to H'FF by a reset, stand-by, module stop, or CTL stop.

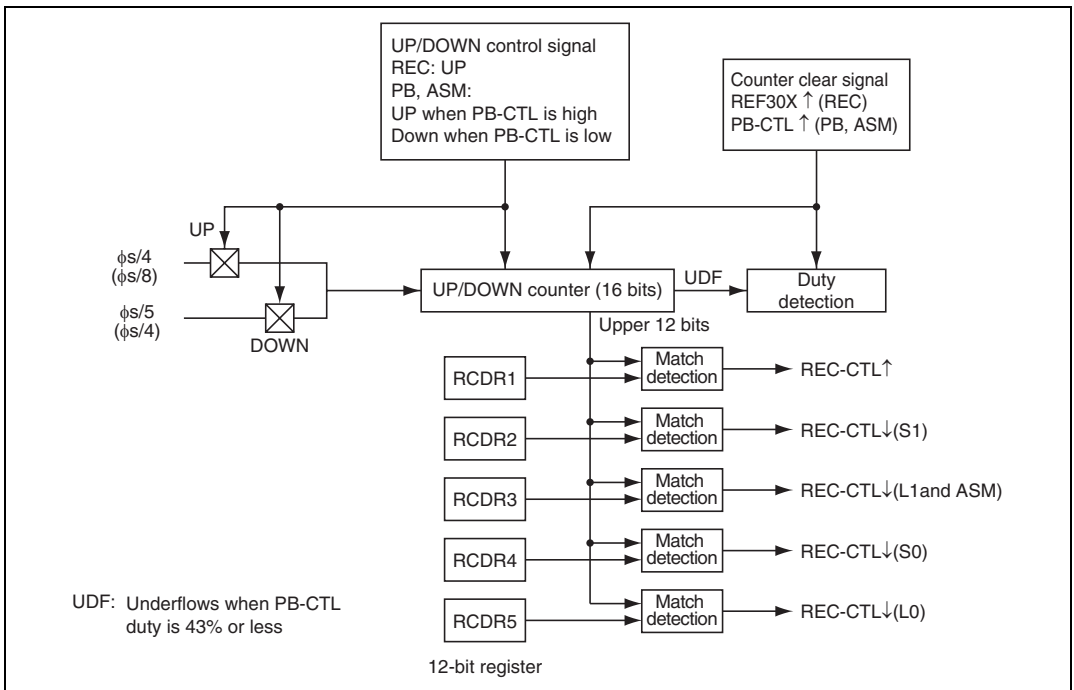
### 28.13.6 Operation

**CTL Circuit Operation:** As shown in figure 28.49, the CTL discrimination/record circuit is composed of a 16-bit up/down counter and 12-bit registers (×5).

In playback (PB) mode, the 16-bit up/down counter counts on a  $\phi s/4$  clock when the PB-CTL pulse is high, and on a  $\phi s/5$  clock when low. In record (REC) or slow mode, this counter counts up on a  $\phi s/8$  clock when the pulse is high, and on a  $\phi s/4$  clock when low.

This counter always counts up in record and slow modes.

In playback or slow mode, it is cleared on the rise of a PB-CTL signal. In record mode, it is cleared on the rise of an REF30X signal.

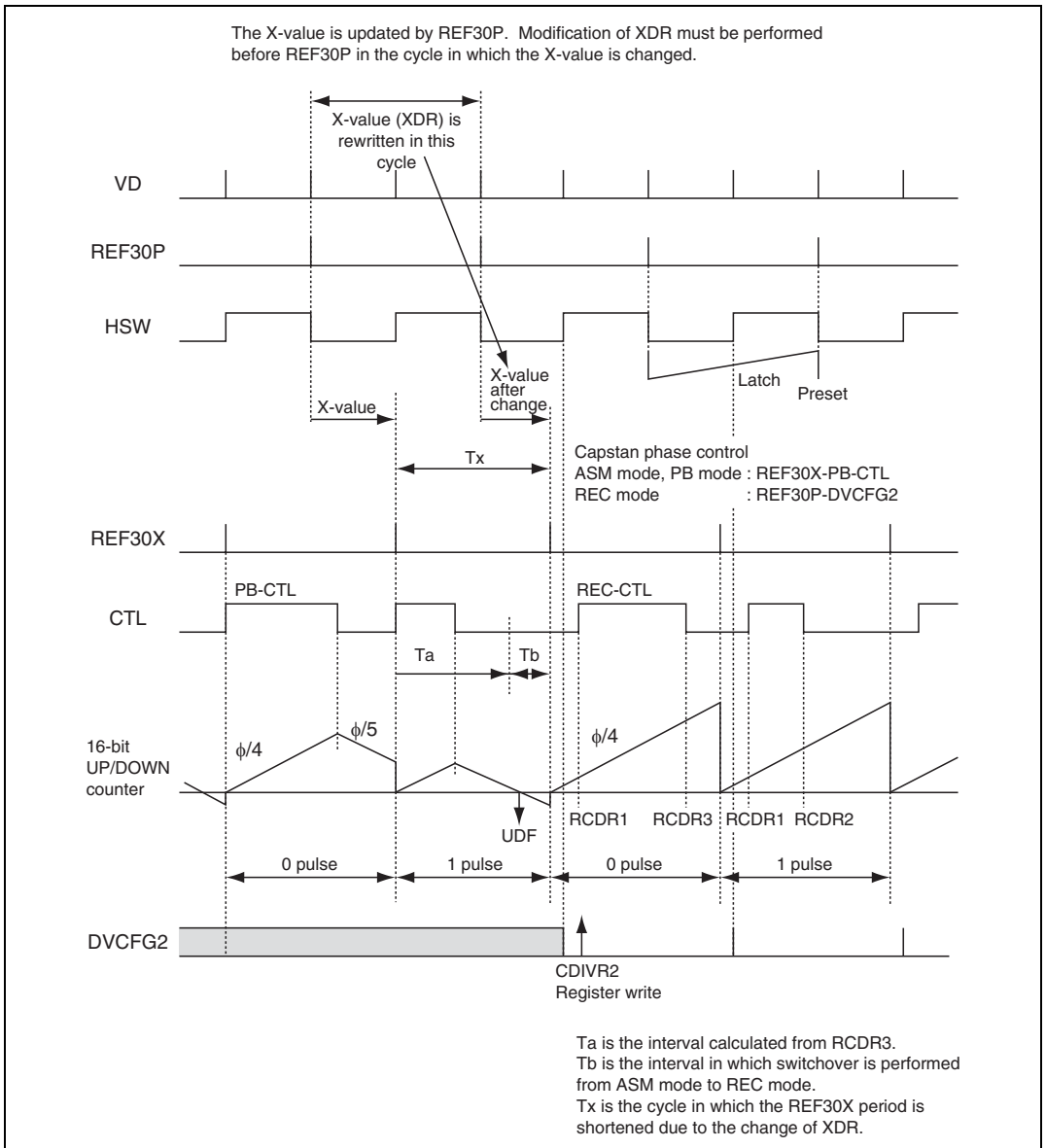


**Figure 28.49 CTL Discrimination/Record Circuit**

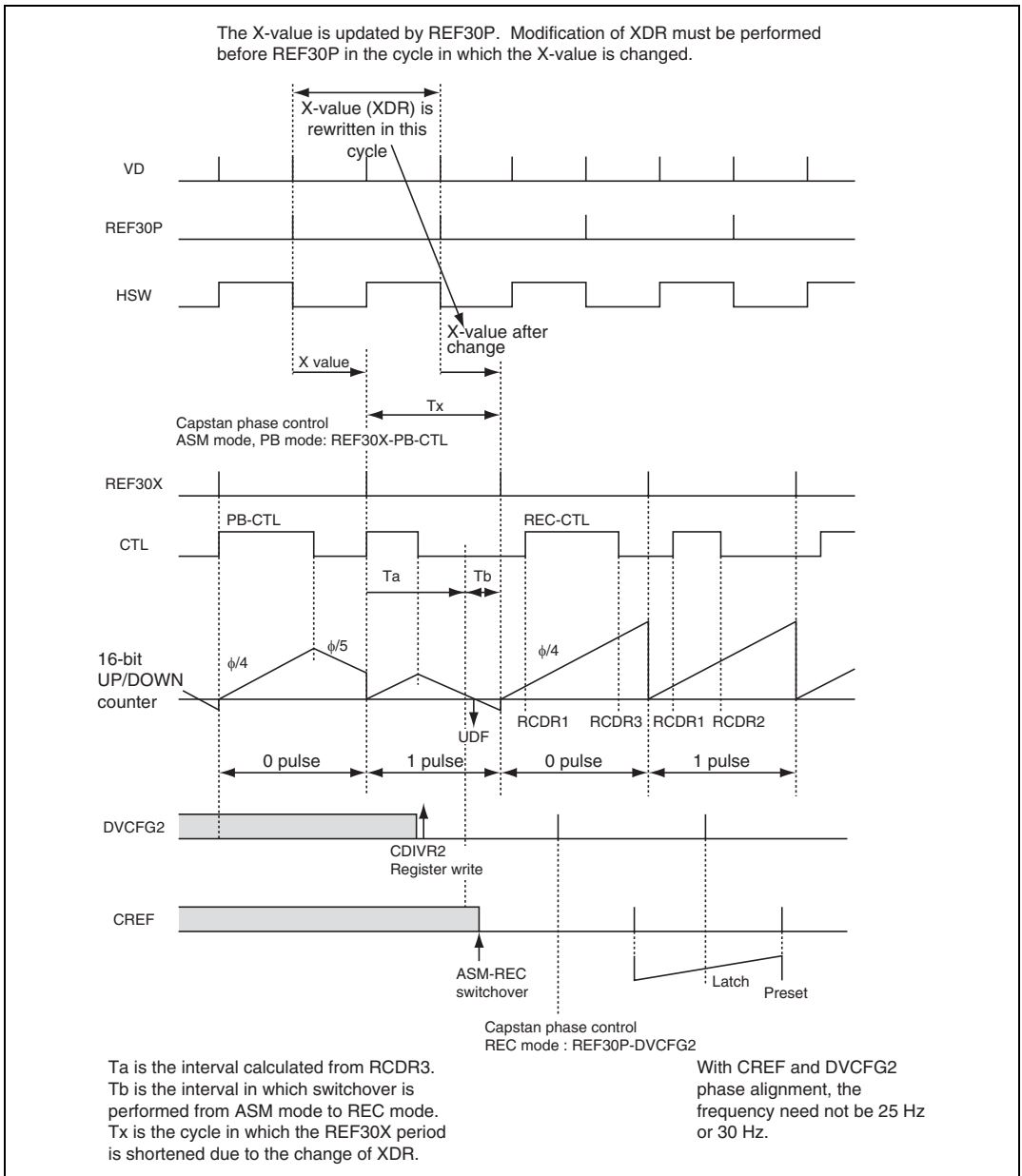
**CTL Mode Register (CTLM) Switchover Timing:** CTLM is enabled immediately after data is written to the register. Care must be taken with changes in the operating state.

Capstan phase control is performed by the VD sync REF30X (X-value + tracking value) and PB-CTL in ASM mode, and by the REF30X or CREF and CFG division signal (DVCFG2) in REC

mode. If the CAPREF30 signal to be used for capstan phase control is always generated by XDR, the value of XDR must be overwritten when switching between PB and REC modes. Figures 28.50 and 28.51 show examples of switchover timing of CTLM and XDR.



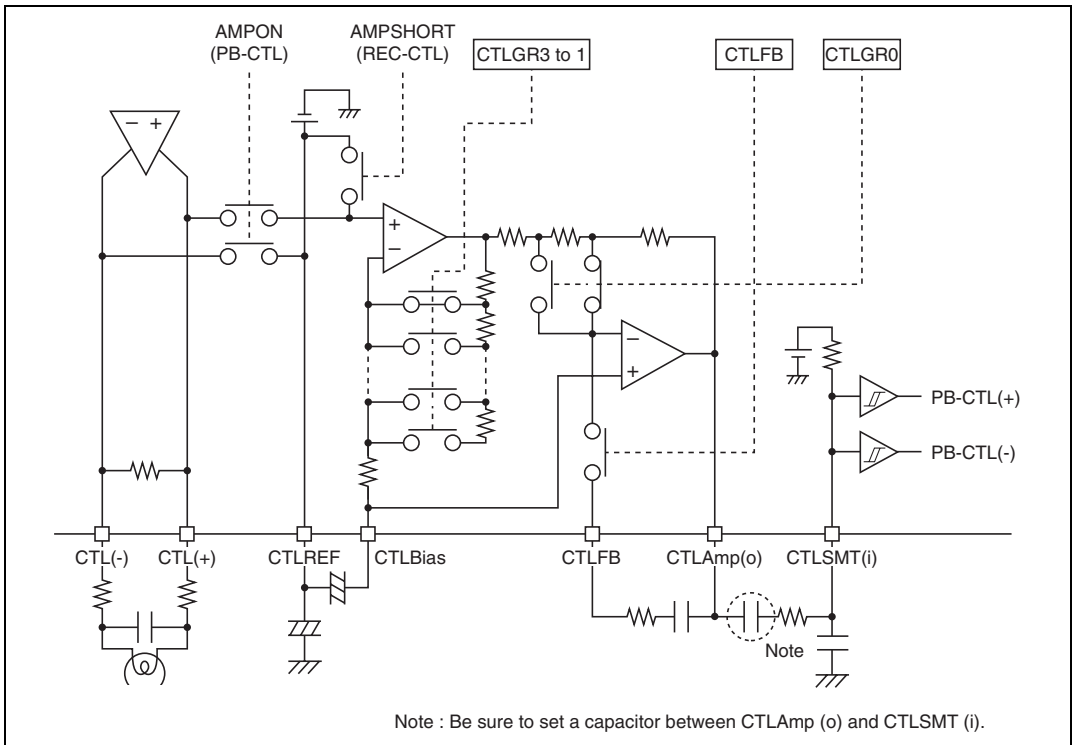
**Figure 28.50 Example of CTLM Switchover Timing**  
 (when Phase Control Is Performed by REF30P and DVCFG2 in REC Mode)



**Figure 28.51 Example of CTLM Switchover Timing (when Phase Control Is Performed by CREF and DVCFG2 in REC Mode)**

### 28.13.7 CTL Input Section

The CTL input section consists of an input amplifier whose gain can be controlled by register setting and a Schmitt amplifier. Figure 28.52 shows a block diagram of the CTL input section. A trivial CTL pulse signal is received from the CTL head, amplified by the input amplifier, reshaped into a square wave by the Schmitt amplifier, and sent to the servo circuits and timer L as the PB-CTL signal. Control the CTL input amplifier gain by bits 3 to 0 in the CTL gain control register (CTLGR) of the servo port.



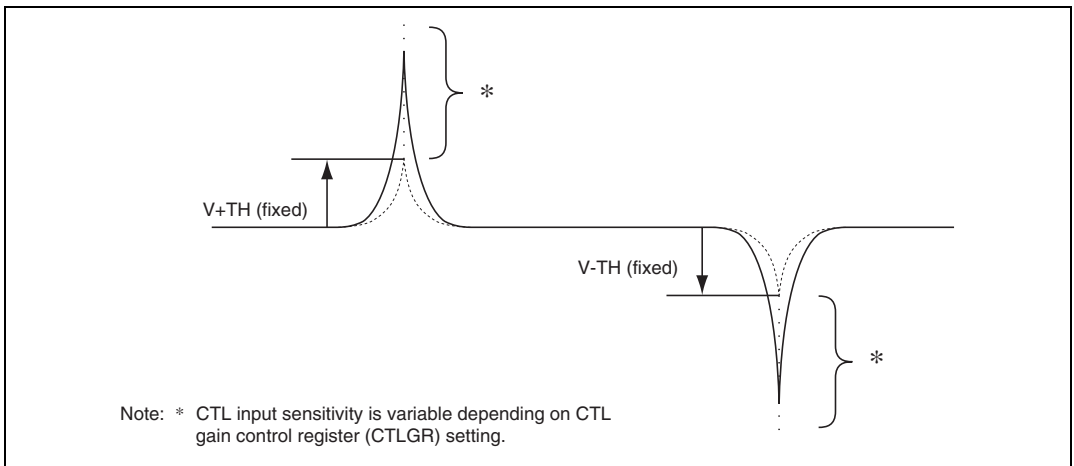
**Figure 28.52 Block Diagram of CTL Input Section**

**(1) CTL Detector**

If the CTL detector fails to detect a CTL pulse, it sets bit 1 of the CTL control register (CTCR) to high indicating that the pulse has not been detected. If a CTL pulse is detected after that, the bit is automatically cleared to 0. Duration used for determining detection or non-detection of the pulse depends on magnitude of phase shift of the last detected pulse from the reference phase (phase difference between REF30 and CTL signal). Typically, detection or non-detection is determined within 3 to 4 cycles of the reference period.

If settings of the CTL gain control register are maintained in a table format, you can refer to it when the CTL detector failed to detect CTL pulses. From the table, you can control input sensitivity of the CTL according to the state of the UNCTL bit, thereby selecting an optimum CTL amplifier gain depending on the state of the pulse recorded.

Figure 28.53 illustrates the concept of gain control for detecting the CTL input pulse.



**Figure 28.53 CTL Input Pulse Gain Control**

## (2) PB-CTL Waveform Shaper in Slow Mode Operation

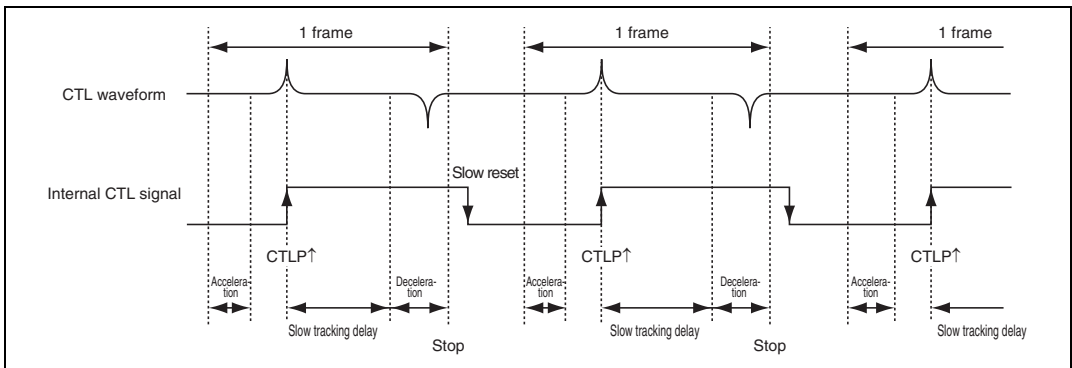
If bit 0 in the CTL control register (CTCR) is set to slow mode, slow reset function is activated. In slow mode, if the falling edge is not detected within the specified time from rising edge detection, PB-CTL is forcibly shut down (slow reset).

The time  $T_{FS}$  (s) until the signal falls is the following interval after the rising edge of the internal CTL signal is detected:

$$T_{FS} = 16384 \times 4\phi \text{ s} \quad (\phi s = f_{osc}/2)$$

When  $f_{osc} = 10 \text{ MHz}$ ,  $T_{FS} = 13.1 \text{ ms}$ .

Figure 28.54 shows the PB-CTL waveform in slow mode.



**Figure 28.54 PB-CTL Waveform in Slow Mode Operation**

### 28.13.8 Duty Discriminator

The duty discriminator circuit measures the period of the control signal recorded on the tape (PB-CTL signal) and discriminates its duty cycle. In VISS or VASS detection, the duty I/O flag is set or cleared according to the result of duty discrimination. The duty I/O flag is set to 1 when the duty cycle of the PB-CTL signal is equal to or above 44%, and is cleared to 0 when the duty cycle is below 43%.

In ASM detection, an ASM mark is recognized (and the duty I/O flag is cleared to 0) when the duty cycle is equal to or above 66%. When the duty cycle is below 65%, no ASM mark is recognized and the duty I/O flag is set to 1.

The detection direction can be switched between forward and reverse by bit 5 (FW/RV) in the CTL mode register.

A long or short pulse can be detected by comparing the REC-CTL duty data register (RCDR2 to RCDR5) and UP/DOWN counter. Long or short pulse is discriminated at PB-CTL signal falling. Discrimination result is stored in bit 0 (LSP0) of the bit pattern register (BTPR). At the same time, BTPR is shifted to the left. LSP0 indicates 0 when a short pulse is detected, and 1 when a long pulse is detected.

Set the threshold value of a long/short pulse in RCDR2 to RCDR5. See (4), Detection of the Long/Short Pulse.

Figure 28.55 shows the duty cycle of the PB-CTL signal.



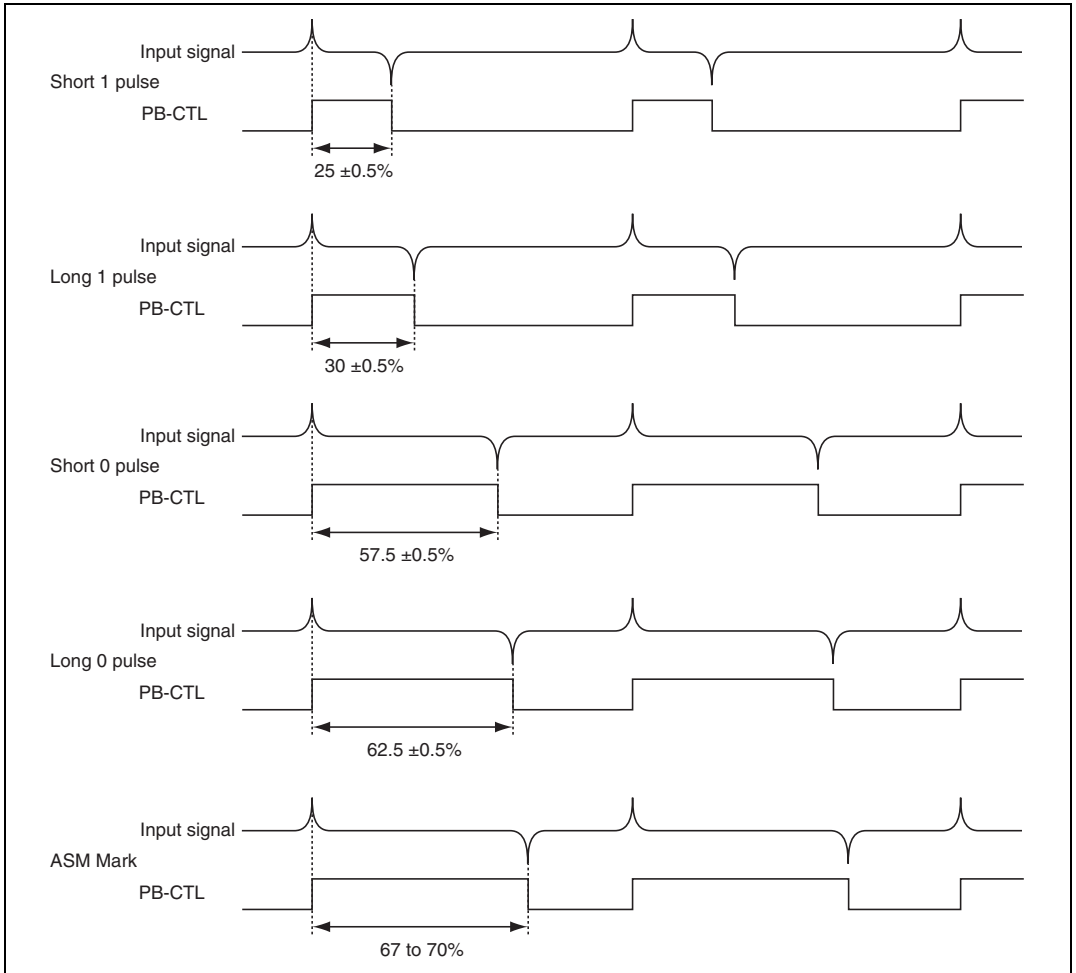
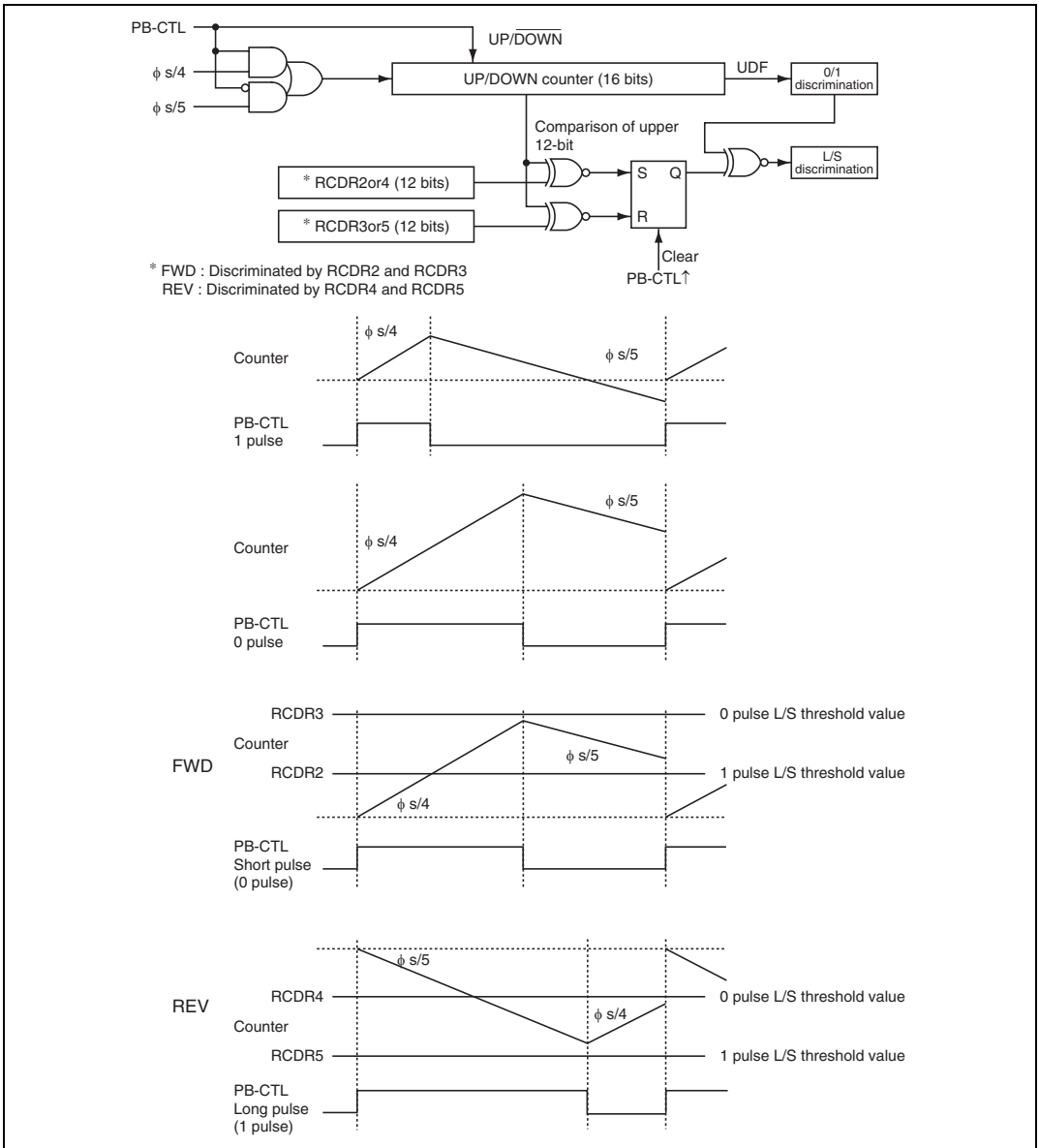
**Figure 28.55 PB-CTL Signal Duty Cycle**

Figure 28.56 shows the duty discrimination circuit. A 44% duty cycle is discriminated by counting with the 16-bit up/down counter, using a  $\phi s/4$  clock for the up-count and a  $\phi s/5$  clock for the down-count. An up-count is performed when the PB-CTL signal is high, and a down-count when low. Long or short pulse is discriminated by comparing with RCDR2 to RCDR5.



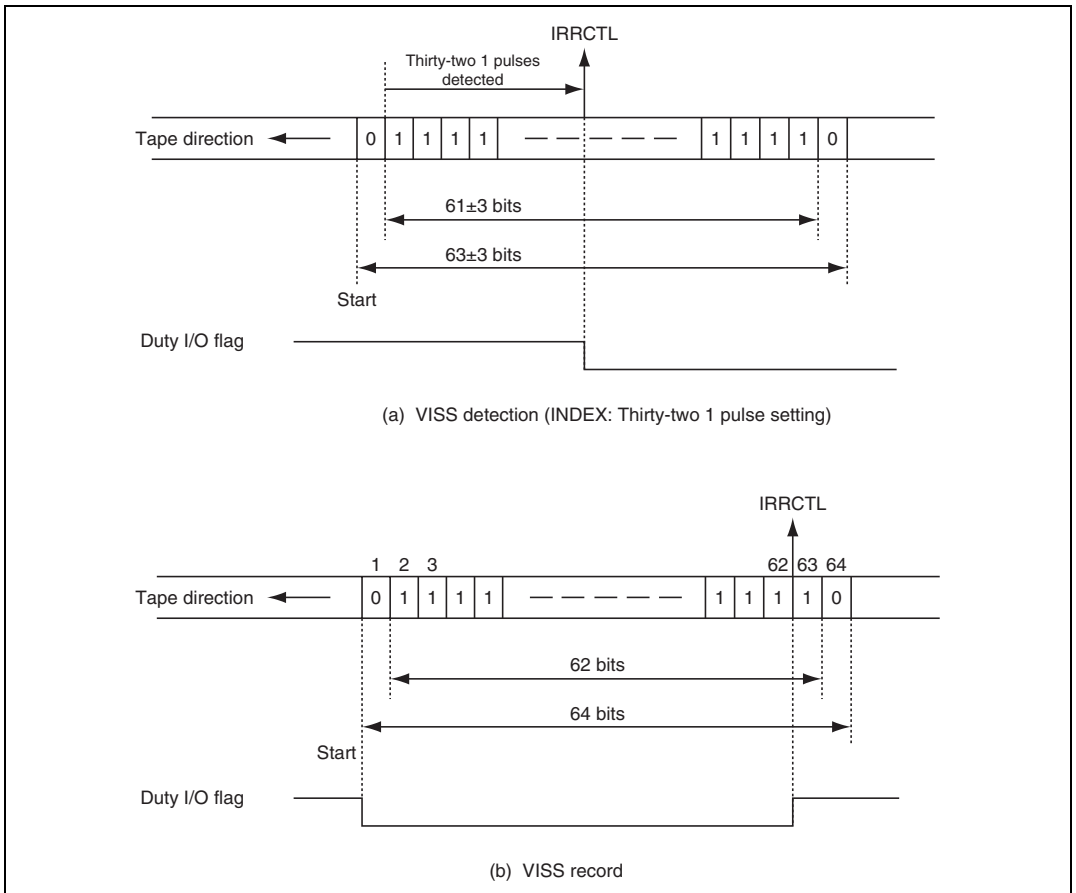
**Figure 28.56 Duty Discriminator**

### (1) VISS (Index) Detect/Record Mode

VISS detection is carried out by the VISS control circuit, which counts 1 pulses in the PB-CTL signal. If the pulse count detects any value set in the VISS interrupt setting bits (bits 5, 6, and 7 in the duty I/O register), an interrupt request is generated and the duty I/O flag is cleared to 0.

At VISS record or rewrite, INDEX code is automatically written. INDEX code is composed of continuous 62-bit data with 0 pulse data at both edges.

Examples of bit strings and the duty I/O flag at VISS detection/record are illustrated in figure 28.57.



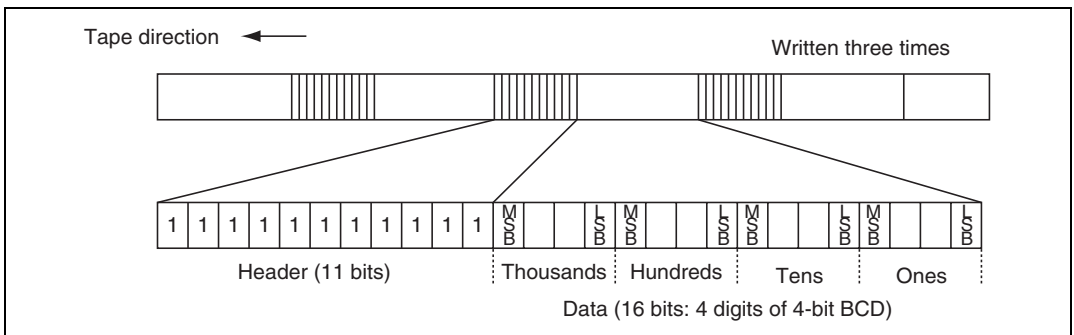
**Figure 28.57** Examples of VISS Bit Strings and Duty I/O Flag

## (2) VASS Detect Mode

VASS detection is carried out by the duty discriminator. Software can detect index sequences by reading the duty I/O flag at each CTL pulse.

At each CTL pulse, the duty discriminator sends the result of duty discrimination to the duty I/O flag, and simultaneously generates an interrupt request. The duty I/O flag is cleared to 0 if the CTL pulse is a 1 (duty cycle below 43%), and is set to 1 if the CTL pulse is a 0 (duty cycle equal to or above 44%).

The duty I/O flag is modified at each CTL pulse. It should be read by the interrupt-handling routine within the period of the PB-CTL signal. The VASS detection format is illustrated in figure 28.58.



**Figure 28.58 VASS (Index) Format**

## (3) Assemble (ASM) Mark Detect Mode

ASM mark detection is carried out by the duty discriminator. If the duty discriminator detects that the duty cycle of the PB-CTL signal is 66% or higher, it generates an interrupt request, and simultaneously clears the duty I/O flag to 0.

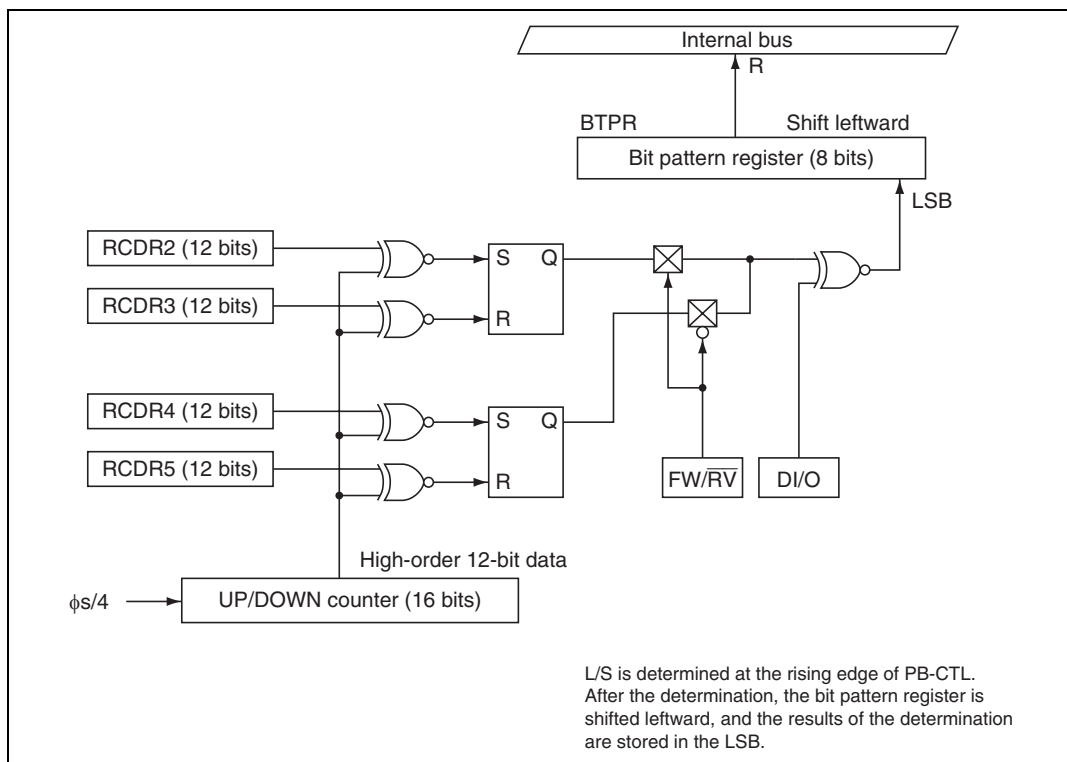
The duty I/O flag is updated at every CTL pulse. It should be read by the interrupt-handling routine within the period of the PB-CTL signal.

#### (4) Detection of the Long/Short Pulse

The Long/Short pulse is detected in PB mode by the L/S determination based on the comparison of the REC-CTL duty registers (RCDR2 to RCDR5) with the up/down counter and the results of the duty I/O flag. The results of the determination are stored in bit 0 (LSP0) of the bit pattern register (BTPR) at the rising edge of PB-CTL, shifting BTPR leftward at the same time.

RCDR2 to RCDR5 set the L/S thresholds for each of FWD/REV. Set to RCDR2 a threshold of 1 pulse L/S for FWD, to RCDR3 a threshold of 0 pulse L/S for FWD, to RCDR4 a threshold of 0 pulse L/S for REV, and to RCDR5 a threshold of 1 pulse L/S for REV. Figure 28.59 shows the detection of the Long/Short pulse.

Also, the bit pattern of eight bits can be detected by BTPR. Check that an 8-bit detection has been done by bit 1 (BPF bit) of the duty I/O register, and then read BTPR.



**Figure 28.59** Detection of Long/Short Pulse

### 28.13.9 CTL Output Section

An on-chip control head amplifier is provided for writing the REC-CTL signal generated by the write control circuit onto the tape.

The write control circuit controls the duty cycle of the REC-CTL signal in the writing of VISS and VASS sequences and ASM marks and the rewriting of VISS and VASS sequences. The duty cycle of the REC-CTL signal is set in REC-CTL duty data registers 1 to 5 (RCDR1 to RCDR5). Times calculated in terms of  $\phi_s (= f_{osc}/2)$  should be converted to appropriate data to be set in these registers. In VISS or VASS mode, set RCDR2 for a duty cycle of  $25\% \pm 0.5\%$ , RCDR3 for a duty cycle of  $30\% \pm 0.5\%$ , RCDR4 for a duty cycle of  $57.5 \pm 0.5\%$ , and RCDR5 for a duty cycle of  $62.5 \pm 0.5\%$ . When 1 is written in the duty I/O flag, the REC-CTL signal will be written on the tape with a  $25\% \pm 0.5\%$  duty cycle when 0 is written in bit 7 (LSP7) in the bit pattern register (BTPR) and with a  $30 \pm 0.5\%$  duty cycle when 1 is written. Table 28.21 shows the relationship between the REC-CTL duty register and CTL outputs.

In ASM mark write mode, set RCDR3 for a duty cycle of 67% to 70%. An ASM mark will be written when 0 is written in the duty I/O flag.

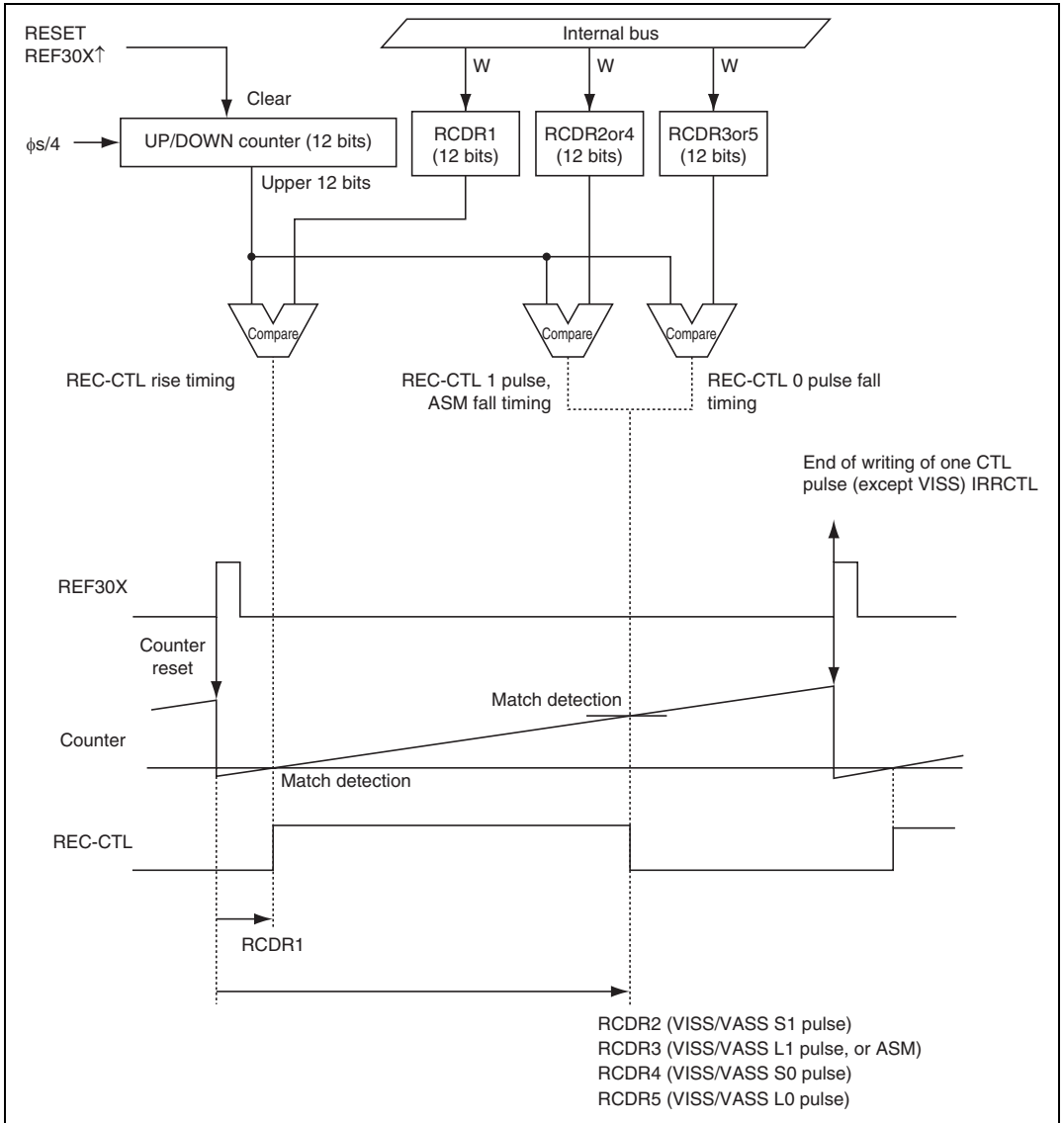
An interrupt request is generated at the rise of the reference signal after one CTL pulse has been written. The reference signal is derived from the output signal (REF30X) of the X-value adjustment circuit, and has a period of one frame.

Figure 28.60 shows the timings that generate the REC-CTL signal.

**Table 28.21 REC-CTL Duty Register and CTL Outputs**

MODE	D/I/O	LSP7	Pulse	RCDR	Duty
VISS and VASS modes	0	0	S1	RCDR2	$25 \pm 0.5\%$
		1	L1	RCDR3	$30 \pm 0.5\%$
	1	0	S0	RCDR4	$57.5 \pm 0.5\%$
		1	L0	RCDR5	$62.5 \pm 0.5\%$
ASM mode	0	*	—	RCDR3	67 to 70%

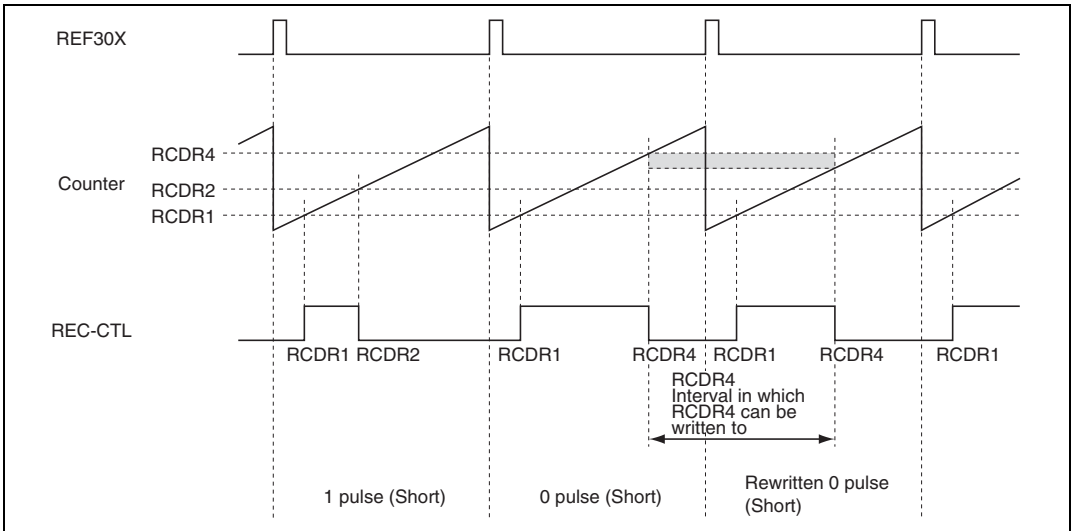
Legend: \* Don't care.



**Figure 28.60 REC-CTL Signal Generation Timing**

The 16-bit counter in the REC-CTL circuit continues counting on a clock derived by dividing the system clock  $\phi_s$  ( $= f_{osc}/2$ ) by 4. The counter is cleared on the rise of REF30X in record mode, and on the rise of PB-CTL in rewrite mode. The REC-CTL match detection is carried out by comparing the counter value with each RCDR value.

RCDR1 to RCDR5 can be written to by software at all times. If RCDR is changed before the respective match detection is performed, match detection is performed using the new value. The value changed after match detection becomes valid on the rise of REF30X following the change. Figure 28.61 shows an example of RCDR change timing.



**Figure 28.61 Example of RCDR Change Timing (Example Showing RCDR4)**

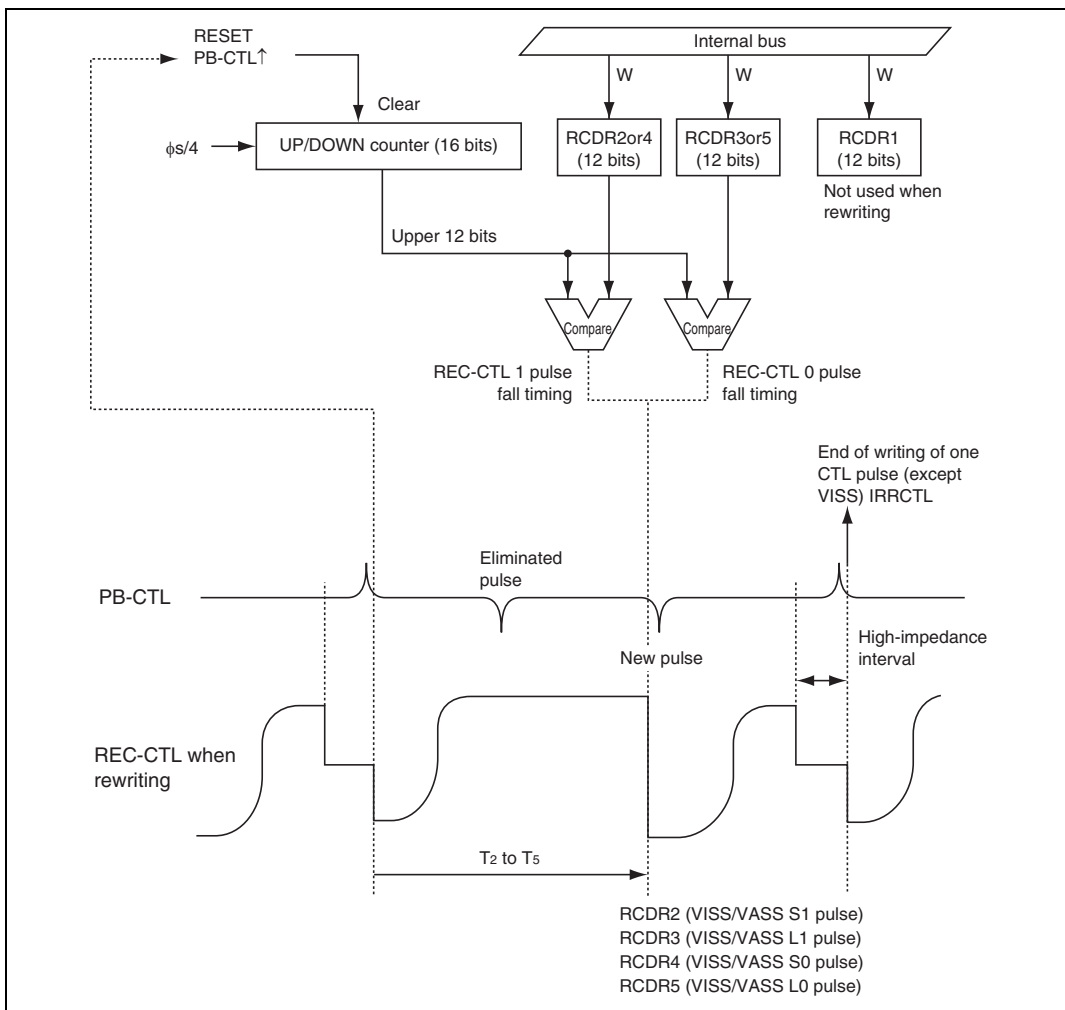


### 28.13.10 Trapezoid Waveform Circuit

In rewriting, the trapezoid waveform circuit leaves the rising edge of the already-recorded PB-CTL signal intact, but changes the duty cycle.

In rewriting, the CTL pulse is written with reference to the rise of PB-CTL. The CTL duty cycle for a rewrite is set in the REC-CTL duty data registers (RCDR2 to RCDR5). Time values T2 to T5 are referenced to the rise of PB-CTL.

Figure 28.62 shows the rewrite waveform.



**Figure 28.62 Relationship between REC-CTL and RCDR2 to RCDR5 when Rewriting**

### 28.13.11 Note on CTL Interrupt

Following a reset, the CTL circuit is in the VASS detect (duty detect) mode. Depending on the CTL pin states, a false PB-CTL input pulse may be recognized and an interrupt request generated. If the interrupt request will be enabled, first clear the CTL interrupt request flag.

## 28.14 Frequency Dividers

### 28.14.1 Overview

On-chip frequency dividers are provided for the pulse signal picked up from the control track during playback (PB-CTL signal), and the pulse signal received from the capstan motor (CFG signal). An on-chip noise canceller is provided for the drum motor pulse signal (DFG signal). The CTL frequency divider generates a CTL divided control signal (DVCTL) from the PB-CTL signal, for use in capstan phase control during high-speed search, for example. The CFG frequency divider generates two divided signals (DVCFG for speed control and DVCFG2 for phase control) from the CFG signal. The DFG noise canceller is a circuit which considers a signal less than  $2\phi$  as noise and masks it.

### 28.14.2 CTL Frequency Divider

#### (1) Block Diagram

Figure 28.63 shows a block diagram of the CTL frequency divider.

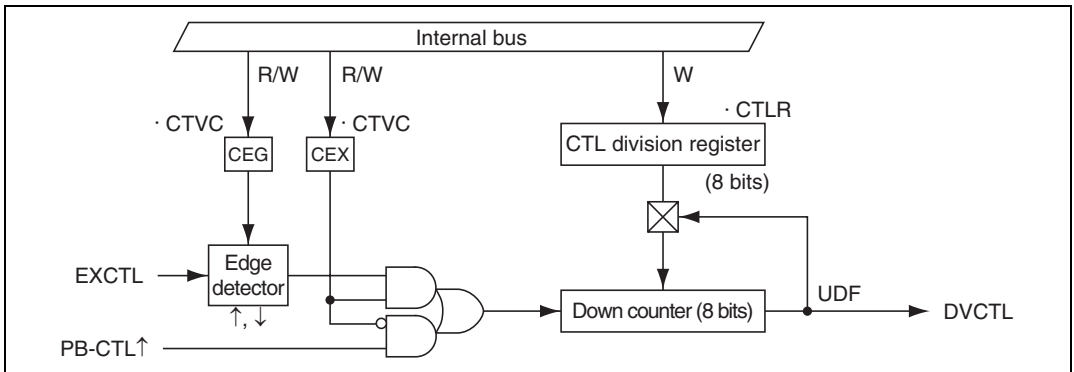


Figure 28.63 CTL Frequency Divider

## (2) Register Configuration

### Register Configuration

Table 28.22 shows the register configuration of the CTL dividers.

**Table 28.22 Register Configuration**

Name	Abbrev.	R/W	Size	Initial Value	Address
DVCTL control register	CTVC	R/W	Byte	Undefined	H'FD098
CTL division register	CTLR	W	Byte	H'00	H'FD099

### DVCTL Control Register (CTVC)

Bit :	7	6	5	4	3	2	1	0
	CEX	CEG	—	—	—	CFG	HSW	CTL
Initial value :	0	0	1	1	1	*	*	*
R/W :	W	W	—	—	—	R	R	R

Note: \* Undefined.

The DVCTL control register (CTVC) is a register consisting of the external input signal selection bit and the flags which show the CFG, HSW, and CTL levels.

Note: It has an undetermined value by a reset or stand-by.

**Bit 7—DVCTL Signal Generation Selection Bit (CEX):** Selects whether the PB-CTL signal or the external input signal is used to generate the DVCTL signal.

#### Bit 7

CEX	Description
0	Generates DVCTL signal with PB-CTL signal (Initial value)
1	Generates DVCTL signal with external input signal

**Bit 6—External Sync Signal Edge Selection Bit (CEG):** Selects the edge of the external signal at which the frequency division is made when the external signal was selected to generate the DVCTL signal.

#### Bit 6

CEG	Description
0	Rising edge (Initial value)
1	Falling edge

**Bits 5 to 3—Reserved:** No write in them is valid. If a read is attempted, an undetermined value is read out.

**Bit 2—CFG Flag (CFG):** Shows the CFG level.

#### Bit 2

CFG	Description
0	CFG is at Low level (Initial value)
1	CFG is at High level

**Bit 1—HSW Flag (HSW):** Shows the level of the HSW signal selected by the VFF/NFF bit of the HSW mode register 2 (HSM2).

#### Bit 1

HSW	Description
0	HSW is at Low level (Initial value)
1	HSW is at High level

**Bit 0—CTL Flag (CTL):** Shows the CTL level.

#### Bit 0

CTL	Description
0	REC or PB-CTL is at Low level (Initial value)
1	REC or PB-CTL is at High level

### CTL Frequency Division Register (CTLR)

Bit :	7	6	5	4	3	2	1	0
	CTL7	CTL6	CTL5	CTL4	CTL3	CTL2	CTL1	CTL0
Initial value :	0	0	0	0	0	0	0	0
R/W :	W	W	W	W	W	W	W	W

The CTL frequency division register (CTLR) is an 8-bit write-only register to set the frequency dividing value (N-1 if divided by N) for PB-CTL. If a read is attempted, an undetermined value is read out.

PB-CTL is divided by N at its rising edge. If the register value was 0, no division operation is performed, and the DVCTL signal with the same cycle with PB-CTL is output. It is initialized to H'00 by a reset or stand-by.

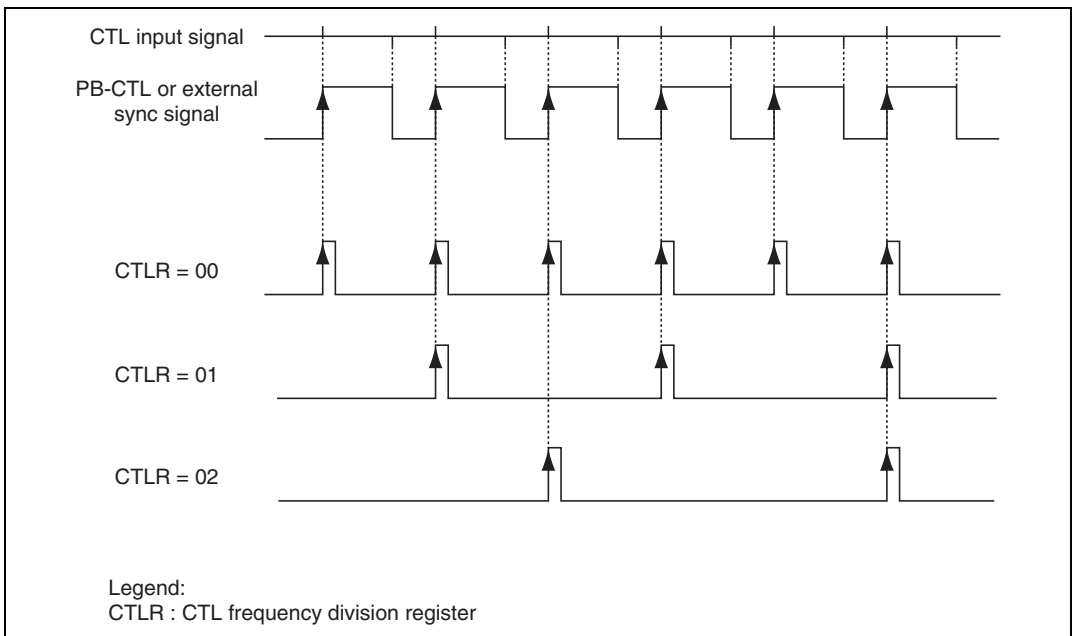
### (3) Operation

During playback, control pulses recorded on the tape are picked up by the control head and input to the CTL pin. The control pulse signal is amplified by a Schmitt amplifier, reshaped, then input to the CTL frequency divider as the PB-CTL signal.

This circuit is employed when the control pulse (PB-CTL signal) is used for phase control of the capstan motor. The divided signal is sent as the DVCTL signal to the capstan phase system in the servo circuits, and the Timer R.

The CTL frequency divider is an 8-bit reload timer consisting of a reload register and a down-counter. Frequency division is obtained by setting frequency-division data in bits 7 to 0 in the CTL frequency division register (CTLR), which is the reload register. When a frequency-division value is written in this reload register, it is also written into the down-counter. The down-counter is decremented on rising edges of the PB-CTL signal.

Figure 28.64 shows examples of the PB-CTL signal and DVCTL waveforms.



**Figure 28.64 CTL Frequency Division Waveforms**

### 28.14.3 CFG Frequency Divider

#### (1) Block Diagram

Figure 28.65 shows a block diagram of the 7-bit CFG frequency divider and its mask timer.

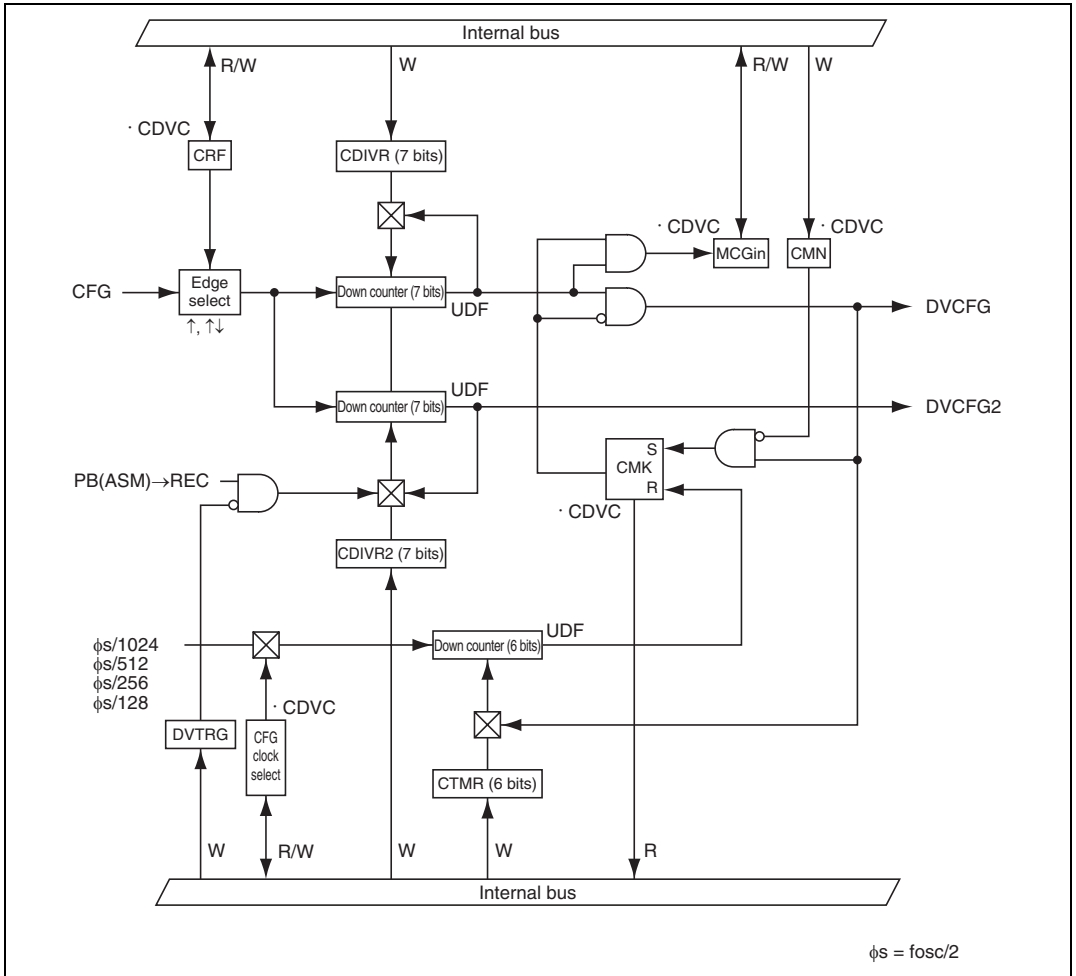


Figure 28.65 CFG Frequency Divider

## (2) Register Descriptions

### Register configuration

Table 28.23 shows the register configuration of the CFG frequency divider.

**Table 28.23 Register Configuration**

Name	Abbrev.	R/W	Size	Initial Value	Address
DVCFG control register	CDVC	R/W	Byte	H'60	F'FD09A
CFG frequency division register 1	CDIVR1	W	Byte	H'80	H'FD09B
CFG frequency division register 2	CDIVR2	W	Byte	H'80	H'FD09C
DVCFG mask period register	CTMR	W	Byte	H'FF	H'FD09D

### DVCFG Control Register (CDVC)

Bit :	7	6	5	4	3	2	1	0
	MCGin	—	CMK	CMN	DVTRG	CRF	CPS1	CPS0
Initial value :	0	1	1	0	0	0	0	0
R/W :	R/W*	—	R	W	W	W	W	W

Note: \* Only 0 can be written.

CDVC is an 8-bit register to control the capstan frequency division circuit. It is initialized to H'60 by a reset, stand-by or module stop.

**Bit 7—Mask CFG Flag (MCGin):** MCGin is a flag to indicate occurrence of a frequency division signal during the mask timer's mask period. To clear it, write 0. To clear it by software, write 0 after reading 1. Also, setting has the highest priority in this flag. If a condition setting the flag and 0 write occurs simultaneously, the latter is nullified.

#### Bit 7

MCGin	Description
0	CFG is in normal operation (Initial value)
1	Shows that DVCFG was detected during masking (runaway detected)

**Bit 6—Reserved:** No write in it is valid. If a read is attempted, 1 is read out.

**Bit 5—CFG Mask Status Bit (CMK):** Indicates the status of the mask. It is initialized to 1 by a reset, stand-by or module stop.

**Bit 5**

CMK	Description
0	Indicates that the capstan mask timer has released masking
1	Indicates that the capstan mask timer is currently masking (Initial value)

**Bit 4—CFG Mask Selection Bit (CMN):** Selects the turning ON/OFF of the mask function.

**Bit 4**

CMN	Description
0	Capstan mask timer function ON (Initial value)
1	Capstan mask timer function OFF

**Bit 3—PB (ASM) → REC Transition Timing Sync ON/OFF Selection Bit (DVTRG):** Selects the ON/OFF of the timing sync of the transition from PB (ASM) to REC when the DVCFG2 signal is generated.

**Bit 3**

DVTRG	Description
0	PB (ASM) → REC transition timing sync ON (Initial value)
1	PB (ASM) → REC transition timing sync OFF

**Bit 2—CFG Frequency Division Edge Selection Bit (CRF):** Selects the edge of the CFG signal to be divided.

**Bit 2**

CRF	Description
0	Performs frequency division at the rising edge of CFG (Initial value)
1	Performs frequency division at both edges of CFG



**Bits 1 and 0—CFG Mask Timer Clock Selection Bits (CPS1, CPS0):** Selects the clock source for the CFG mask timer. ( $\phi_s = f_{osc}/2$ )

Bit 1	Bit 0	
CPS1	CPS0	Description
0	0	$\phi_s/1024$ (Initial value)
	1	$\phi_s/512$
1	0	$\phi_s/256$
	1	$\phi_s/128$

### CFG Frequency Division Register 1 (CDIVR1)

Bit :	7	6	5	4	3	2	1	0
	—	CDV16	CDV15	CDV14	CDV13	CDV12	CDV11	CDV10
Initial value :	1	0	0	0	0	0	0	0
R/W :	—	W	W	W	W	W	W	W

The CFG frequency division register 1 (CDIVR1) is an 8-bit write-only register to set the CFG division value (N-1 for N division). If a read is attempted, an undetermined value is read out. Bit 7 is reserved.

The frequency division value is written in the reload register and the down counter at the same time.

CFG's frequency is divided by N at its rising edge or both edges. If the register value was 0, no division operation is performed, and the DVCFG signal with the same input cycle with the CFG signal is output. The DVCFG signal is sent to the capstan speed error detector. It is initialized to H'80 by a reset or stand-by together with the capstan frequency division register and the down counter.

### CFG Frequency Division Register 2 (CDIVR2)

Bit :	7	6	5	4	3	2	1	0
	—	CDV26	CDV25	CDV24	CDV23	CDV22	CDV21	CDV20
Initial value :	1	0	0	0	0	0	0	0
R/W :	—	W	W	W	W	W	W	W

The CFG frequency division register 2 (CDIVR2) is an 8-bit write-only register to set the CFG division value (N-1 for N division). If a read is attempted, an undetermined value is read out. Bit 7 is reserved.

The frequency division value is written in the reload register and the down counter at the same time.

CFG's frequency is divided by N at its rising edge or both edges. If the register value was 0, no division operation is performed, and the DVCFG signal with the same input cycle with the CFG signal is output. The DVCFG2 signal is sent to the capstan speed error detector and the Timer L.

The DVCFG2 circuit has no mask timer function.

The frequency division counter for the DVCFG2 signal starts its division operation at the point data was written in CDIVR2. If synchronization is required for phase matching, for example, do it by writing in CDIVR2. If the DVTRG bit of the CDVC register was 0, the register synchronizes with the switching timing from PB (ASM) to REC.

It is initialized to H'80 by a reset or stand-by together with the capstan frequency division register and the down counter.

### DVCFG mask period register (CTMR)

Bit :	7	6	5	4	3	2	1	0
	—	—	CPM5	CPM4	CPM3	CPM2	CPM1	CPM0
Initial value :	1	1	1	1	1	1	1	1
R/W :	—	—	W	W	W	W	W	W

The DVCFG mask period register (CTMR) is an 8-bit write-only register. If a read is attempted, an undetermined value is read out. CTMR is a reload register for the mask timer (down counter). Set in it the mask period of CFG. The mask period is determined by the clock specified by bits 1 and 0 of CDVC and the set value (N-1). If data is written in CTMR, it is written also in the mask timer at the same time.

It is initialized to H'FF by a reset, stand-by or module stop.

Mask period =  $N \times$  clock cycle

### (3) Operation

#### Frequency divider

The CFG pulses output from the capstan motor are sent to internal circuitry as the CFG signal via the zero-cross type comparator. The CFG signal, shaped into a rectangular waveform by a reshaping circuit, is divided by the CFG frequency dividers, and used in servo control. The rising edge or both edges of the CFG signal can be selected for the frequency divider.

The CFG frequency dividers comprises a 7-bit frequency divider with a mask timer for capstan speed control (DVCFG signal generator) and a 7-bit frequency divider for capstan phase control (DVCFG2 signal generator).

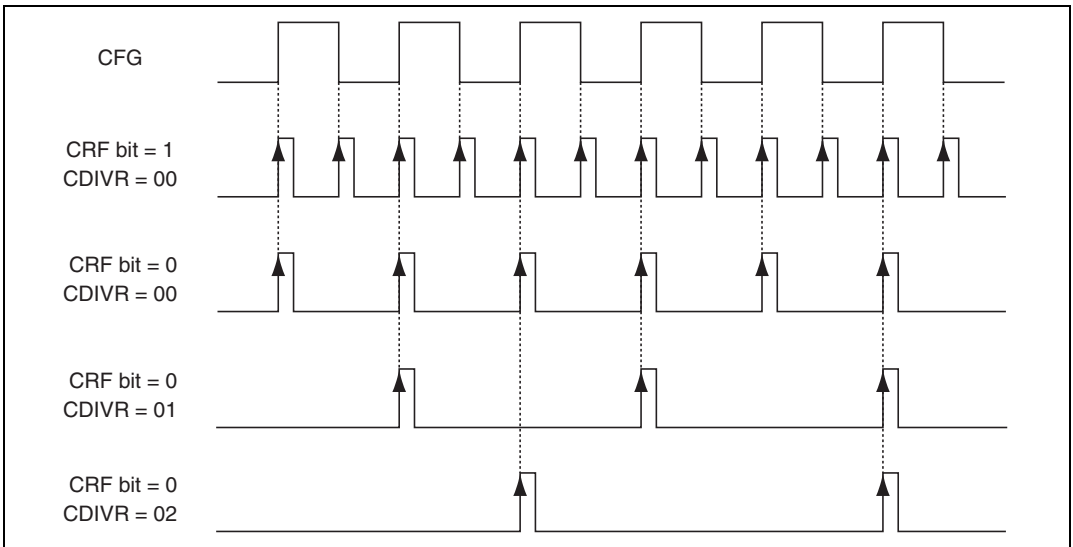
The DVCFG signal generator consists of a 7-bit reload register (CFG frequency division register 1: CDIVR1), a 7-bit down-counter, and a 6-bit mask timer (with settable mask interval). Frequency division is performed by setting the frequency-division value in 7-bit CDIVR1. When the frequency-division value is written in CDIVR1, it is also written in the down-counter. After frequency division of a CFG signal for which the edge has been selected, the signal is sent via the mask timer to the capstan speed error detector as the DVCFG signal.

The DVCFG2 signal generator consists of a 7-bit reload register (CFG frequency division register 2: CDIVR2) and a 7-bit down-counter. The 7-bit frequency divider does not have a mask timer. Frequency division is performed by setting the frequency-division value in CDIVR2. When the frequency-division value is written in CDIVR2, it is also written in the down-counter. After frequency division of a CFG signal for which the edge has been selected, the signal is sent to the capstan speed error detector and the Timer L as the DVCFG2 signal. Frequency division starts when the frequency-division value is written.

When the DVTRG bit in the CDVC register is set to 0, reloading is executed with the switchover timing from PB (ASM) mode to REC mode. To switch from REF30 to CREF, change the settings of bit 4 (CR/RF bit) in the capstan phase error detection control register (CPGCR). If synchronization is necessary for phase control, this can be provided by writing the frequency-division value in CDIVR2.

The down-counters are decremented on rising edges of the CFG signal when the CRF bit is 0 in the DVCFG control register (CDVC), and on both edges when the CRF bit is 1.

Figure 28.66 shows examples of CFG frequency division waveforms.



**Figure 28.66 Frequency Division Waveforms**

### Mask timer

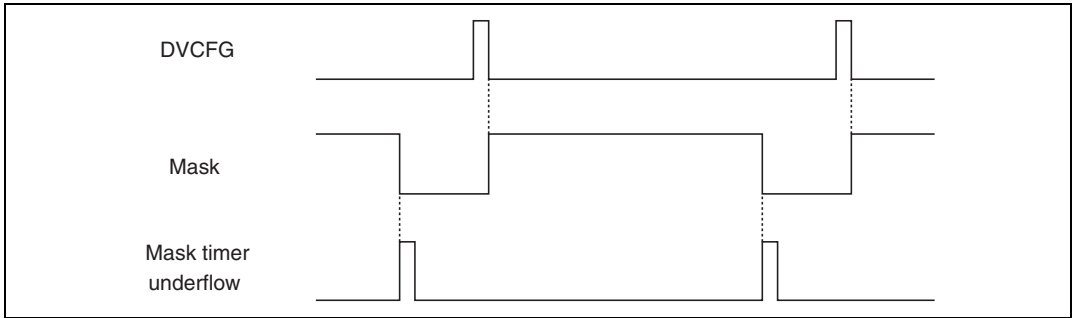
The capstan mask timer is a 6-bit reload timer that uses a prescaled clock as a clock source.

The mask timer is used for masking the DVCFG signal intended for controlling the capstan speeds.

The capstan mask timer prevents edge detection to be carried out for an unnecessarily long duration by masking the edge detection for a certain period. The above trouble can result from abnormal revolution (runout) of the capstan motor because its revolution has to cover a wide range speeds from the slow/still up to the high speed search.

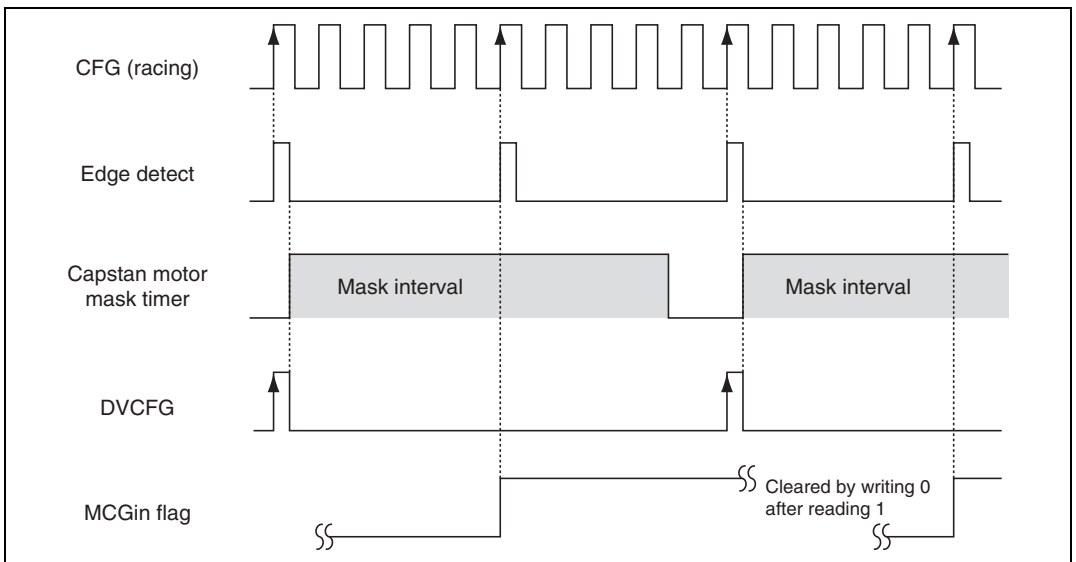
The capstan mask timer is started by output of a pulse edge in the divided CFG signal (DVCFG). While the timer is running, a mask signal disables the output of further DVCFG pulses. The mask signal is shown in figure 28.67.

The mask timer status can be recognized by reading the CMK flag in the DVCFG control register (CDVC).

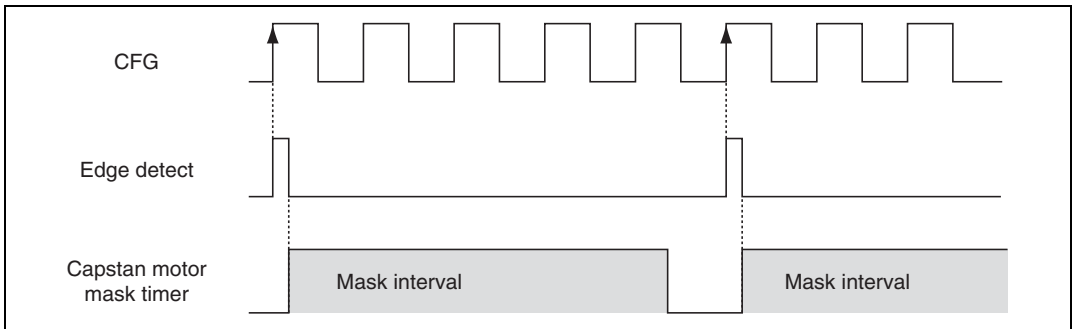


**Figure 28.67 Mask Signal**

Figures 28.68 and 28.69 show examples of CFG mask timer operations.



**Figure 28.68 CFG Mask Timer Operation (When Capstan Motor Is Racing)**

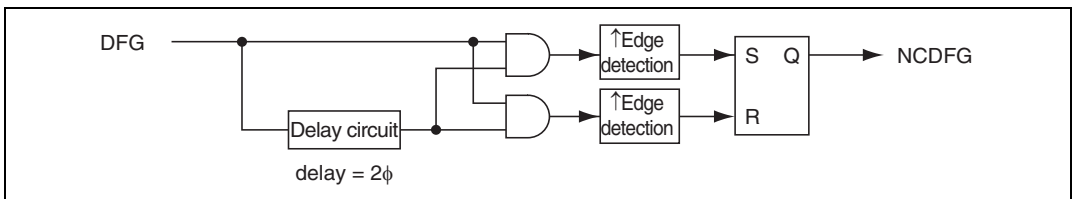


**Figure 28.69 CFG Mask Timer Operation (When Capstan Motor Is Operating Normally)**

## 28.14.4 DFG Noise Removal Circuit

### (1) Block Diagram

Figure 28.70 shows the block diagram of the DFG noise removal circuit.



**Figure 28.70 DFG Noise Removal Circuit**

### (2) Register Descriptions

#### Register configuration

Table 28.24 shows the register configuration of the DFG mask circuit.

**Table 28.24 Register Configuration**

Name	Abbrev.	R/W	Size	Initial Value	Address
FG control register	FGCR	W	Byte	H'FE	H'FD09E

**FG Control Register (FGCR)**

Bit :	7	6	5	4	3	2	1	0
	—	—	—	—	—	—	—	DRF
Initial value :	1	1	1	1	1	1	1	0
R/W :	—	—	—	—	—	—	—	W

Selects the edge of the DFG noise removal signal (NCDFG) to be sent to the drum speed error detector. If a read is attempted, an undetermined value is read out. Bits 7 to 1 are reserved. No write in them is valid.

It is initialized to H'FE by a reset, stand-by or module stop.

The edge selection circuit is located in the drum speed error detector, and outputs the register output to the drum speed error detector.

**Bits 7 to 1—Reserved:** No write in them is valid. If a read is attempted, an undetermined value is read out.

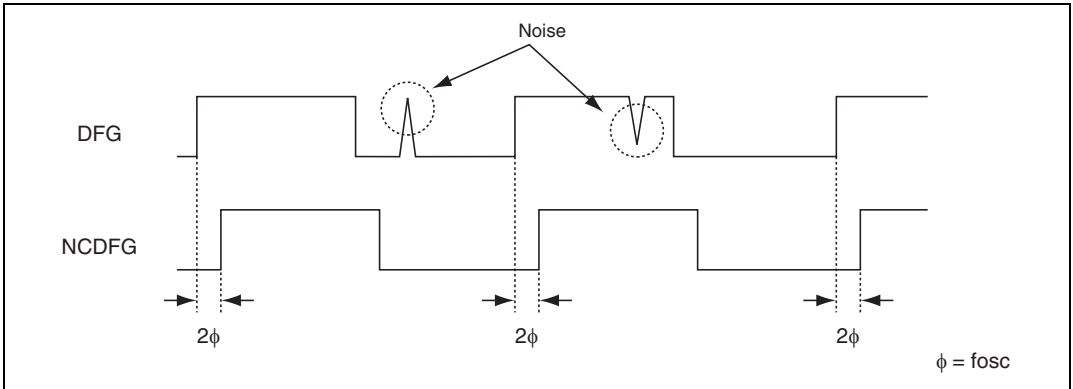
**Bit 0—DFG Edge Selection Bit (DRF):** Selects the edge of the NCDFG signal used in the drum speed error detector.

**Bit 0**

<b>DRF</b>	<b>Description</b>
0	Selects the rising edge of NCDFG signal (Initial value)
1	Selects the falling edge of NCDFG signal

### (3) Description of Operation

The DFG noise removal circuit generates a signal (NCDFG signal) with a delay circuit as a result of removing noise (signal fluctuation smaller than  $2\phi$ ) from the DFG signal. The resulted NCDFG signal is behind the time when the DFG signal was detected by  $2\phi$ . Figure 28.71 shows the NCDFG signal.



**Figure 28.71 NCDFG Signal**



## 28.15 Sync Signal Detector

### 28.15.1 Overview

This block performs detection of the horizontal sync signal (Hsync) and vertical sync signal (Vsync) from the composite sync signal (Csync), noise counting, and field detection.

It detects the horizontal and vertical sync signals by setting threshold in the register and based on the servo clock ( $\phi_s = f_{osc}/2$ ). Noise masking is possible during the detection of the horizontal sync signals, and if any Hsync is missing, it can be supplemented. Also, if total volume of the noise detected in one frame of Csync amounted over a specified volume, the detector generates a noise detection interrupt.

Note: This circuit detects a pulse with a specific width set by the threshold register. It does not classify or restore the sync signal to a formal one.

### 28.15.2 Block Diagram

Figure 28.72 shows the block diagram of the sync signal detector.

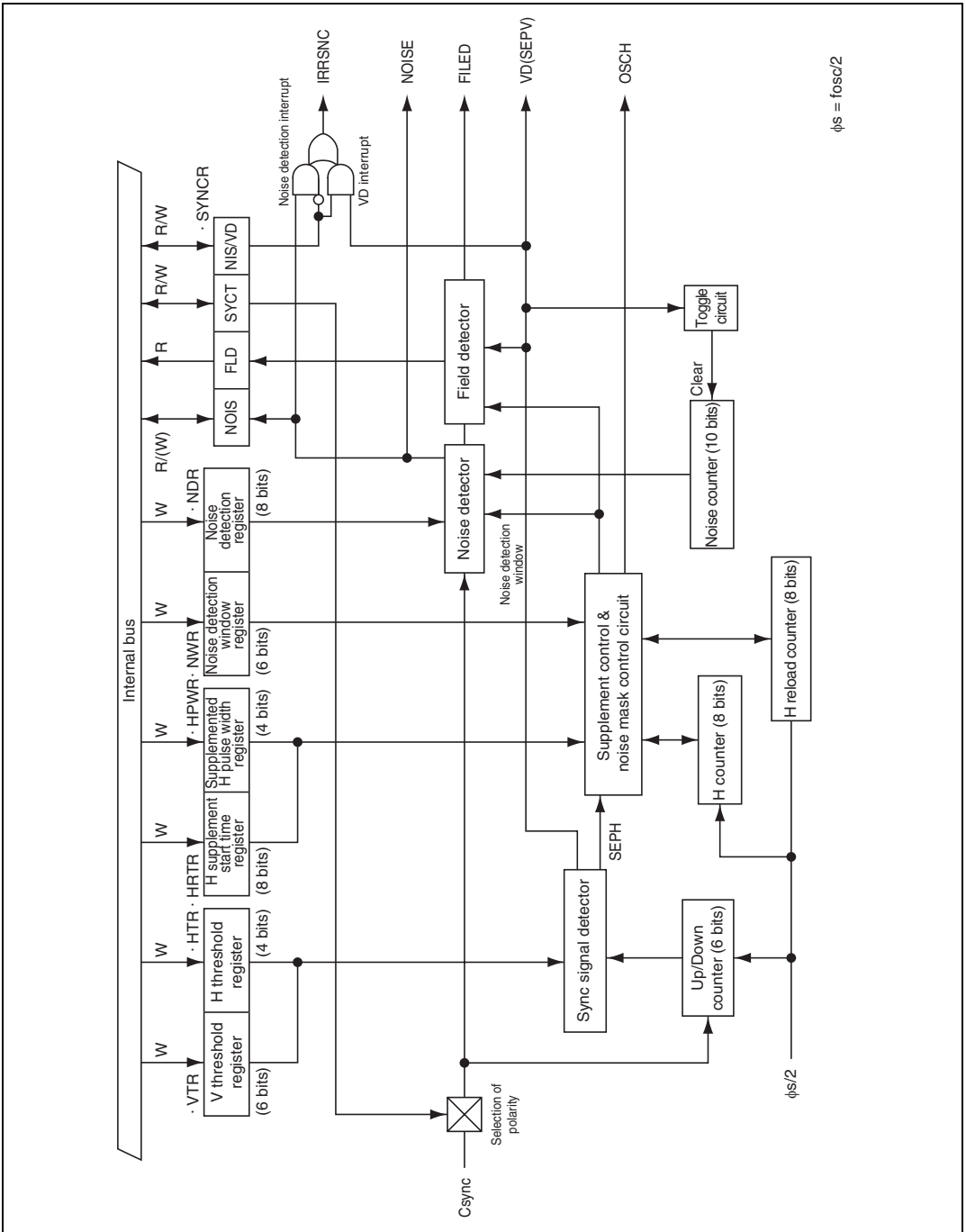


Figure 28.72 Block Diagram of the Sync Signal Detector

### 28.15.3 Pin Configuration

Table 28.25 shows the pin configuration of the sync signal detector.

**Table 28.25 Pin Configuration**

Name	Abbrev.	I/O	Function
Composite sync signal input pin	Csync	Input	Composite sync signal input

### 28.15.4 Register Configuration

Table 28.26 shows the register configuration of the sync signal detector.

**Table 28.26 Register Configuration**

Name	Abbrev.	R/W	Size	Initial Value	Address
Vertical sync signal threshold register	VTR	W	Byte	H'C0	H'FD0B0
Horizontal sync signal threshold register	HTR	W	Byte	H'F0	H'FD0B1
H supplement start time setting register	HRTR	W	Byte	H'00	H'FD0B2
Supplemented H pulse width setting register	HPWR	W	Byte	H'F0	H'FD0B3
Noise detection window setting register	NWR	W	Byte	H'C0	H'FD0B4
Noise detector register	NDR	W	Byte	H'00	H'FD0B5
Sync signal control register	SYNCR	R/W	Byte	H'F8	H'FD0B6

### 28.15.5 Register Descriptions

#### (1) Vertical Sync Signal Threshold Register (VTR)

Bit :	7	6	5	4	3	2	1	0
	—	—	VTR5	VTR4	VTR3	VTR2	VTR1	VTR0
Initial value :	1	1	0	0	0	0	0	0
R/W :	—	—	W	W	W	W	W	W

Sets the threshold for the vertical sync signal when the signal is detected from the composite sync signal. The threshold is set by bits 5 to 0 (VTR5 to VTR0). Bits 7 and 6 are reserved.

VTR is an 8-bit write-only register. If a read is attempted, an undetermined value is read out. It is initialized to H'C0 by a reset, stand-by or module stop.

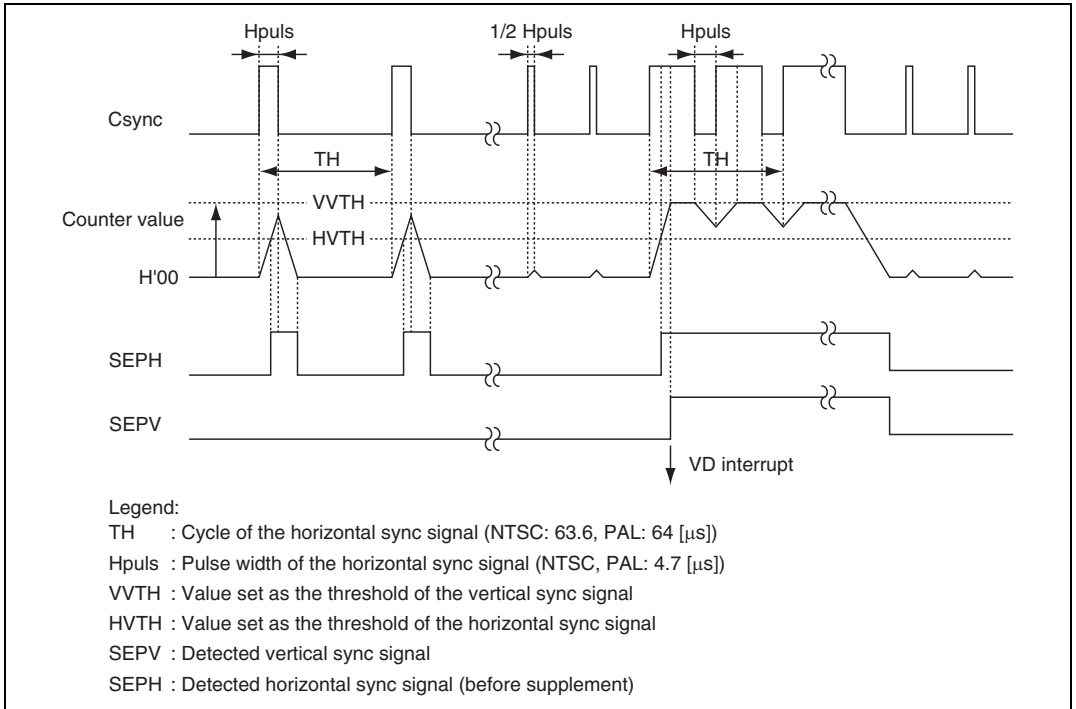
#### (2) Horizontal Sync Signal Threshold Register (HTR)

Bit :	7	6	5	4	3	2	1	0
	—	—	—	—	HTR3	HTR2	HTR1	HTR0
Initial value :	1	1	1	1	0	0	0	0
R/W :	—	—	—	—	W	W	W	W

Sets the threshold for the horizontal sync signal when the signal is detected from the composite sync signal. The threshold is set by bits 3 to 0 (HTR3 to HTR0). Bits 7 and 4 are reserved.

HTR is an 8-bit write-only register. If a read is attempted, an undetermined value is read out. It is initialized to H'F0 by a reset, stand-by or module stop.

Figure 28.73 shows threshold and separated sync signals.



**Figure 28.73 Threshold and Separated Sync Signals**

### Example

The set values to detect the vertical and horizontal sync signals (SEPV and SEPH) from Csync are required to meet the following conditions. Assumed that the set values in the VTNR register were VVTH and HVTH,

$$(VVTH - 1) \times 2/\phi_s > Hpuls$$

$$(HVTH - 2) \times 2/\phi_s \leq Hpuls/2 < (HVTH - 1) \times 2/\phi_s$$

Where, Hpuls is pulse width ( $\mu$ s) of the horizontal sync signal, and  $\phi_s$  is servo clock ( $f_{osc}/2$ ).

Thus, if  $\phi_s = 5$  MHz, NTSC system is used,

$$(VVTH - 1) \times 0.4\mu s > 4.7\mu s$$

$$\therefore VVTH \geq H'D$$

$$(HVTH - 2) \times 0.4\mu s \leq 2.35\mu s < (HVTH - 1) \times 0.4\mu s$$

$$\therefore HVTH \geq H'7$$

Note: This circuit detects the pulse with the width set in the VTNR register. If a noise pulse with the width greater than the set value was input, the circuit regards that it detected a sync signal.

**(3) H Supplement Start Time Setting Register (HRTR)**

Bit :	7	6	5	4	3	2	1	0
	HRTR7	HRTR6	HRTR5	HRTR4	HRTR3	HRTR2	HRTR1	HRTR0
Initial value :	0	0	0	0	0	0	0	0
R/W :	W	W	W	W	W	W	W	W

Sets the timing to generate a supplementary pulse if a drop-out of a pulse of the horizontal sync signal occurred.

HRTR is an 8-bit write-only register. If a read is attempted, an undetermined value is read out. It is initialized to H'00 by a reset, stand-by or module stop.

$$((\text{Value of HRTR7 to HRTR0}) + 1) \times 2/\phi_s = \text{TH}$$

where, TH is the cycle of the horizontal sync signal ( $\mu\text{s}$ ), and  $\phi_s$  is the servo clock ( $f_{\text{osc}}/2$ ).

Whether the horizontal sync signal exists or not is determined one clock before the supplementary pulse is generated. Accordingly, set to HRTR7 to HRTR0 a value obtained from the equation shown above plus one.

Also, HRTR7 to HRTR0 set the noise mask period. If the horizontal sync signal had the normal pulses, it is masked in the mask period.

The start and end of the mask period are computed from the rising edge of OSCH and SEPH, respectively. See figure 28.75.

**(4) Supplemented H Pulse Width Setting Register (HPWR)**

Bit :	7	6	5	4	3	2	1	0
	—	—	—	—	HPWR3	HPWR2	HPWR1	HPWR0
Initial value :	1	1	1	1	0	0	0	0
R/W :	—	—	—	—	W	W	W	W

HPWR sets the pulse width of the supplemented pulse which is generated if a drop-out of a pulse of the horizontal sync signal occurs. Bits 7 to 4 are reserved.

HRWR is an 8-bit write-only register. If a read is attempted, an undetermined value is read out. It is initialized to H'F0 by a reset or stand-by.

$$((\text{Value of HPWR3 to HPWR0}) + 1) \times 2/\phi_s = \text{Hpulse}$$

Where, Hpuls is the pulse width of the horizontal sync signal ( $\mu\text{s}$ ), and  $\phi_s$  is the servo clock ( $f_{\text{osc}}/2$ ).

**(5) Noise Detection Window Setting Register (NWR)**

Bit :	7	6	5	4	3	2	1	0
	—	—	NWR5	NWR4	NWR3	NWR2	NWR1	NWR0
Initial value :	1	1	0	0	0	0	0	0
R/W :	—	—	W	W	W	W	W	W

NWR sets the period (window) when the drop-out of the pulse of the horizontal sync signal is detected and the noise is counted. Set the timing of the noise detection window in bits 5 to 0. Bits 7, and 6 are reserved.

NWR is an 8-bit write-only register. If a read is attempted, an undetermined value is read out. It is initialized to H'C0 by a reset, stand-by or module stop.

Set the value of the noise detection window timing according to the following equation.

$$((\text{Value of NWR5 to NWR0}) + 1) \times 2/\phi_s = 1/4 \times \text{TH}$$

Where, TH is the pulse width of the horizontal sync signal ( $\mu\text{s}$ ), and  $\phi_s$  is the servo clock ( $f_{\text{osc}}/2$ ).

It is recommended that this timing value is set at about 1/4 of the cycle of the horizontal sync signal.

**(6) Noise Detection Register (NDR)**

Bit :	7	6	5	4	3	2	1	0
	NDR7	NDR6	NDR5	NDR4	NDR3	NDR2	NDR1	NDR0
Initial value :	0	0	0	0	0	0	0	0
R/W :	W	W	W	W	W	W	W	W

NDR sets the noise detection level when the noise of the horizontal sync signal is detected (when NWR is set). Set the noise detection level in bits 7 to 0.

NDR is an 8-bit write-only register. No read is valid. If a read is attempted, an undetermined value is read out. It is initialized to H'00 by a reset, stand-by or module stop.

The noise detector takes counts of the drop-outs of the horizontal sync signals and the noises within the pulses, and if they amount to a count greater than four times of the value set in NDR7 to NDR0, the detector sets the NOIS flag in the sync signal control register (SYNCR). Set the noise detection level at 1/4 of the noise counts in one frame.

The noise counter is cleared whenever Vsync was detected twice.

See section 28.15.6, Noise Detection, for the details of the noise detection window and the noise detection level.

**(7) Sync Signal Control Register (SYNCR)**

Bit :	7	6	5	4	3	2	1	0
	—	—	—	—	NIS/VD	NOIS	FLD	SYCT
Initial value :	1	1	1	1	1	0	0	0
R/W :	—	—	—	—	R/W	R/(W)*	R	R/W

Note: \* Only 0 can be written

SYNCR controls the noise detection, field detection, polarity of the sync signal input, etc.

SYNCR is an 8-bit register. It is initialized to H'F8 by a reset, stand-by or module stop. Bits 7 to 4 are reserved. No write is valid. Bit 1 is valid for read only.

**Bits 7 to 4—Reserved:** Writes are disabled. If a read is attempted, an undetermined value is read out.

**Bit 3—Interrupt Selection Bit (NIS/VD):** Selects whether an interrupt request is generated when a noise level was detected or when the VD signal was detected.

**Bit 3**

NIS/VD	Description
0	Interrupt at the noise level
1	Interrupt at VD (Initial value)

**Bit 2—Noise Detection Flag (NOIS):** NOIS is a status flag indicating that the noise counts reached at more than four times of the value set in NDR. The flag is cleared only by writing 0 after reading 1. Care is required because it is not cleared automatically.

**Bit 2**

NOIS	Description
0	Noise count is smaller than four times of the value set in NDR (Initial value)
1	Noise count is equal to or greater than four times of the value set in NDR

**Bit 1—Field Detection Flag (FLD):** Indicates whether the field currently being scanned is even or odd. See figure 28.74.



**Bit 1**

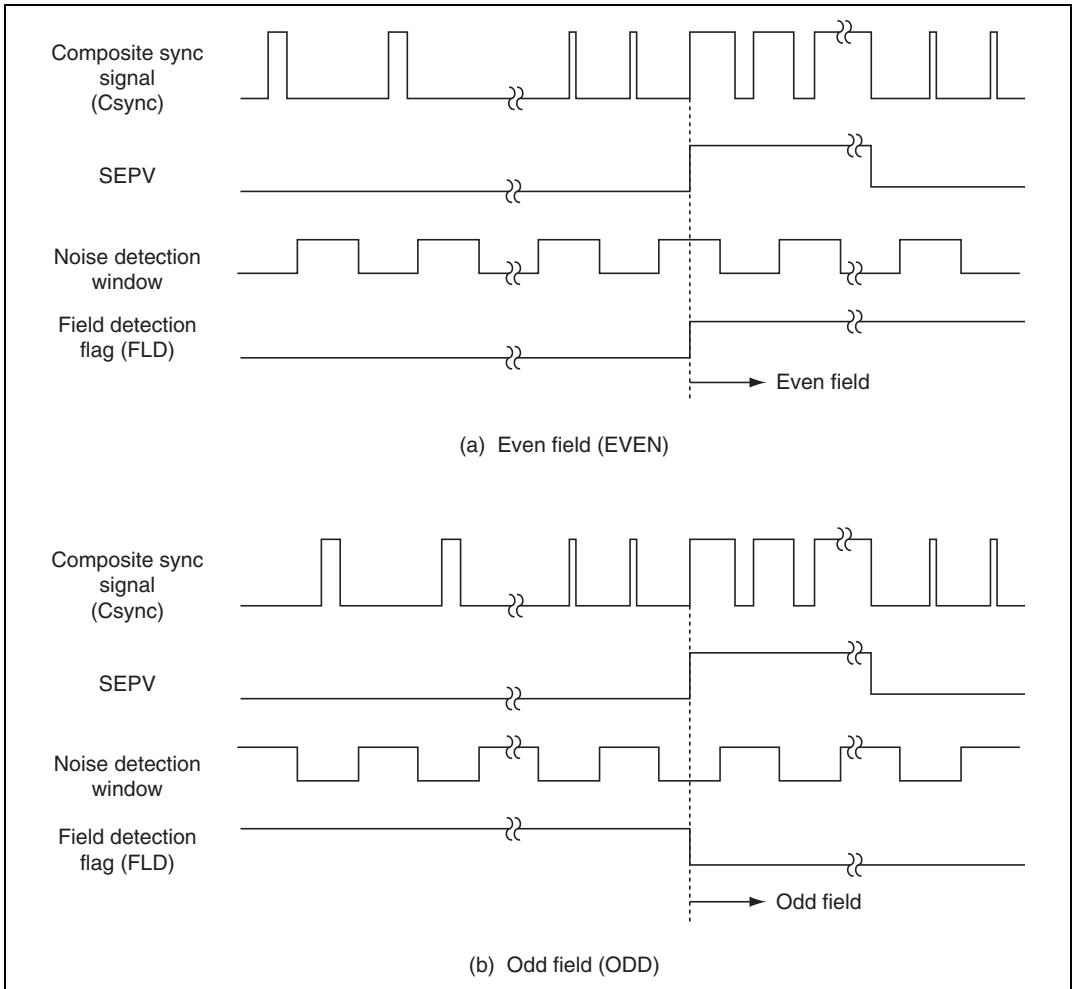
FLD	Description
0	Odd field (Initial value)
1	Even field



**Bit 0—Sync Signal Polarity Selection Bit (SYCT):** Selects the polarity of the sync signal (Csync) to be input.

**Bit 0**

SYCT	Description	Polarity
0		Positive (Initial value)
1		Negative



**Figure 28.74 Field Detection**

### 28.15.6 Noise Detection

If drop-out of a pulse of the horizontal sync signal occurred, set a supplemented pulse at the timing set in HPWR and with the set pulse width.

Set the noise detection window with HWR of about 1/4 of the horizontal sync signal, and the pulse with equal High and Low periods will be obtained.

#### (1) Example of Setting

Assumed that a supplemented pulse is set when  $f_{osc} = 10\text{MHz}$  under the conditions  $\phi_s = 5\text{MHz}$ , NTSC:TH = 63.6 ( $\mu\text{s}$ ) and  $H_{puls} = 4.7$  ( $\mu\text{s}$ ), the set values of the supplemented pulse timing (HRTR7-0), supplemented pulse width (HPWR3-0) and noise detection window timing (NWR5-0) are expressed by the following equations.

$$(\text{Value of HRTR7} - 0) \times 2/\phi_s = \text{TH}$$

$$((\text{Value of HPWR3} - 0) + 1) \times 2/\phi_s = H_{puls}$$

$$((\text{Value of NWR5} - 0) + 1) \times 2/\phi_s = 1/4 \times \text{TH}$$

Where, TH is the cycle of the horizontal sync signal ( $\mu\text{s}$ ),  $H_{puls}$  is the pulse width of the horizontal sync signal ( $\mu\text{s}$ ) and  $\phi_s$  is the servo clock (Hz) ( $f_{osc}/2$ ).

Accordingly,

$$(\text{Value of HRTR7 to HRTR0}) \times 0.4 (\mu\text{s}) = 63.6 (\mu\text{s})$$

$$\therefore \text{HRTR7} - 0 = \text{H'9F}$$

$$((\text{Value of HPWR3 to HPWR0}) + 1) \times 0.4 (\mu\text{s}) = 4.7 (\mu\text{s})$$

$$\therefore \text{HPWR3} - 0 = \text{H'B}$$

$$((\text{Value of NWR5 to NWR0}) + 1) \times 0.4 (\mu\text{s}) = 16 (\mu\text{s})$$

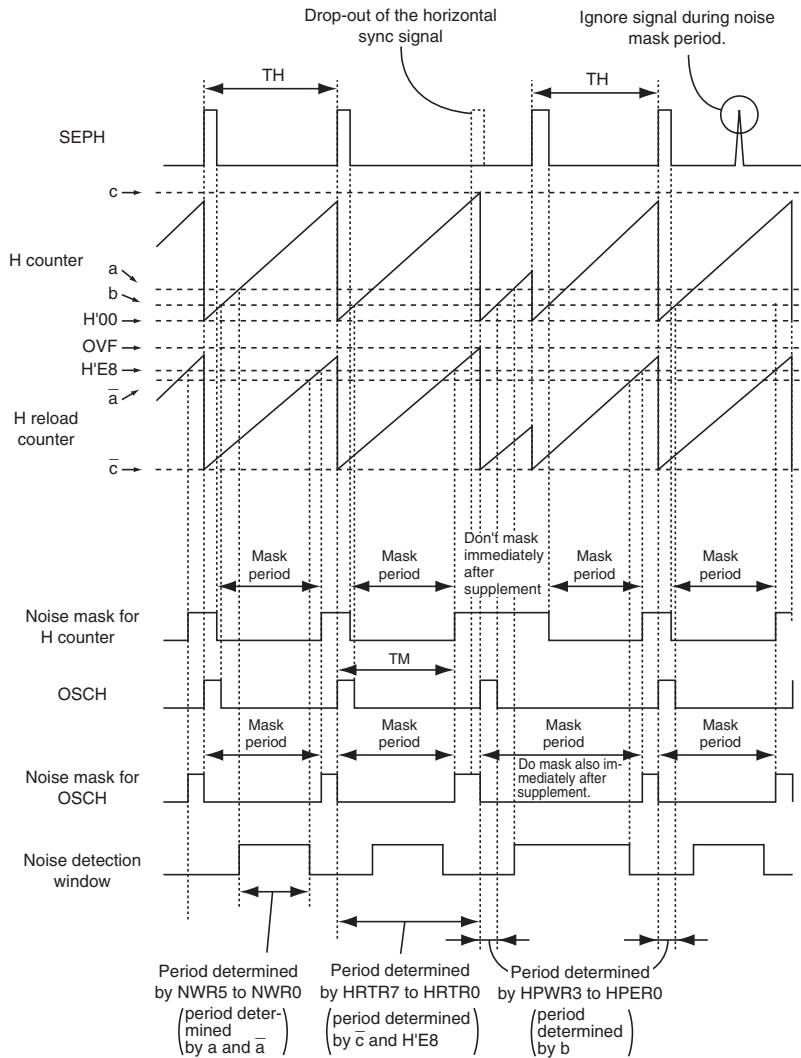
$$\therefore \text{NWR5} - 0 = \text{H'27}$$

Also, the noise mask period is computed as follows.

$$((\text{Value of HRTR7 to HRTR0}) + 1) - 24 \times 2/\phi_s = 54 (\mu\text{s})$$

Where, 24 is a constant required for a structural reason.

Figure 28.75 shows the set period for HRTR, HPWR, and NWR.



## Legend:

SEPH : Horizontal sync signal after detection

OSCH : Horizontal sync signal after supplement

a : Value set for the noise detection window (NWR5 to NWR0)

b : Value set for the pulse width of the horizontal sync signal (NPWR3 to NPWR0)

c : Value set for supplement timing (HRTR7 to HRTR0)

ā, b̄, c̄ : Complements of 1 of a,b,c, respectively

H'E8 : Complement of 2 of multiplier 24 in the equation for the noise mask period

(The noise mask period ends 24 counts before the overflow of H reload counter.)

TH : Cycle of the horizontal sync signal

(NTSC:63.6 [ms], PAL:64[ms])

TM : Timing at which the noise mask period ends.

Figure 28.75 Set Period for HRTR, HPWR and NWR

## (2) Operation to Detect Noise

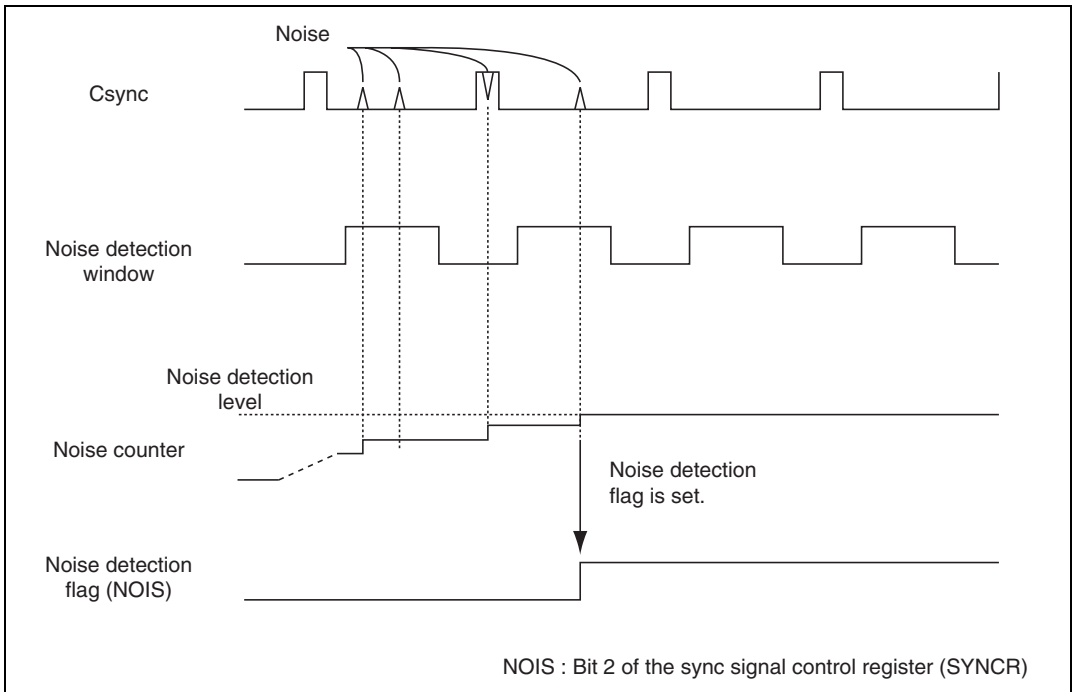
The noise detector considers an irregular pulse of the composite sync signal (Csync) and a chip of a pulse of the horizontal sync signal within a frame as noise. The noise counter takes counts of the irregular pulses during the High period of the noise detection window and the chips and drop-outs of the horizontal sync signal pulses during the Low period. Also, it counts more than one irregular pulses as one. The noise counter is cleared at every frame (Vsync is detected twice).

The equivalent pulse contained in 9H of the vertical sync signal is counted also as an irregular pulse.

It sets the noise detection flag (NOIS) in the sync signal control register (SYNCR) at 1 if the count of the irregular pulses + the count of the pulse chips and drop-outs of the horizontal sync signal  $> 4 \times$  (value of NDR7 to NDR0).

See section 28.15.5 (7), Sync Signal Control Register (SYNCR), for the NOIS bit.

Figure 28.76 shows the operation of the noise detection.



**Figure 28.76 Operation of the NoIse Detection**

### 28.15.7 Sync Signal Detector Activation

The sync signal detector starts operation by release of reset, or by accepting input of a sync signal after its transition from power-down mode to active mode and release of module stop. The signal given to the detector is the polarity pulse assigned by the SYCT bit of the sync signal control register (SYNCR). The detector starts operation even if this pulse was a noise pulse with a width short of the regular width. The minimum pulse width which can activate the detector is not constant depending on the internal operation of the input circuit. Accordingly, if the assured activation of the detector is required, input a pulse with a width greater than  $4/\phi_s$  ( $\phi_s = f_{osc}/2$  (Hz)). In such a case, care is required to noise, etc., because even a pulse with a width smaller than  $4\phi/s$  may cause activation.

## 28.16 Servo Interrupt

### 28.16.1 Overview

The interrupt exception processing of the servo module is started by one of ten factors, i.e. the drum speed error detector ( $\times 2$ ), drum phase error detector, capstan speed error detector ( $\times 2$ ), capstan phase error detector, HSW timing generator ( $\times 2$ ), sync detector and CTL circuit. For these interrupt factors, see each of their circuit sections in this manual.

Also, see section 5, Exception Handling.

### 28.16.2 Register Configuration

Table 28.27 shows the list of the registers which control the interrupt of the servo section.

**Table 28.27 Registers which Control the Interrupt of the Servo Section**

Name	Abbrev.	R/W	Size	Initial Value	Address
Servo interrupt permission register 1	SIENR1	R/W	Byte	H'00	H'FD0B8
Servo interrupt permission register 2	SIENR2	R/W	Byte	H'FC	H'FD0B9
Servo interrupt request register 1	SIRQR1	R/W	Byte	H'00	H'FD0BA
Servo interrupt request register 2	SIRQR2	R/W	Byte	H'FC	H'FD0BB

### 28.16.3 Register Description

#### (1) Servo Interrupt Permission Register 1 (SIENR1)

Bit :	7	6	5	4	3	2	1	0
	IEDRM3	IEDRM2	IEDRM1	IECAP3	IECAP2	IECAP1	IEHSW2	IEHSW1
Initial value :	0	0	0	0	0	0	0	0
R/W :	R/W	R/W	R/W	R/W	R/W	R/W	R/W	R/W

SIENR1 controls the permission and prohibition of the interrupt of the servo section. SIENR1 is an 8-bit readable/writable register. It is initialized to H'00 by a reset, stand-by or module stop.

**Bit 7—Drum Phase Error Detection Interrupt Permission Bit (IEDRM3)****Bit 7**

<b>IEDRM3</b>	<b>Description</b>
0	Prohibits the interrupt request through IRRDRM3 (Initial value)
1	Permits the interrupt request through IRRDRM3

**Bit 6—Drum Speed Error Detection (Lock Detection) Interrupt Permission Bit (IEDRM2)****Bit 6**

<b>IEDRM2</b>	<b>Description</b>
0	Prohibits the interrupt request through IRRDRM2 (Initial value)
1	Permits the interrupt request through IRRDRM2

**Bit 5—Drum Speed Error Detection (OVF, Latch) Interrupt Permission Bit (IEDRM1)****Bit 5**

<b>IEDRM1</b>	<b>Description</b>
0	Prohibits the interrupt request through IRRDRM1 (Initial value)
1	Permits the interrupt request through IRRDRM1

**Bit 4—Capstan Phase Error Detection Interrupt Permission Bit (IECAP3)****Bit 4**

<b>IECAP3</b>	<b>Description</b>
0	Prohibits the interrupt request through IRRCAP3 (Initial value)
1	Permits the interrupt request through IRRCAP3

**Bit 3—Capstan Speed Error Detection (Lock Detection) Interrupt Permission Bit (IECAP2)****Bit 3**

<b>IECAP2</b>	<b>Description</b>
0	Prohibits the interrupt request through IRRCAP2 (Initial value)
1	Permits the interrupt request through IRRCAP2

**Bit 2—Capstan Speed Error Detection (OVF, Latch) Interrupt Permission Bit (IECAP1)****Bit 2**

IECAP1	Description
0	Prohibits the interrupt request through IRRCAP1 (Initial value)
1	Permits the interrupt request through IRRCAP1

**Bit 1—HSW Timing Generation (Counter Clear, Capture) Interrupt Permission Bit (IEHSW2)****Bit 1**

IEHSW2	Description
0	Prohibits the interrupt request through IRRHSW2 (Initial value)
1	Permits the interrupt request through IRRHSW2

**Bit 0—HSW Timing Generation (OVW, Matching, STRIG) Interrupt Permission Bit (IEHSW1)****Bit 0**

IEHSW1	Description
0	Prohibits the interrupt request through IRRHSW1 (Initial value)
1	Permits the interrupt request through IRRHSW1

**(2) Servo Interrupt Permission Register 2 (SIENR2)**

Bit :	7	6	5	4	3	2	1	0
	—	—	—	—	—	—	IESNC	IECTL
Initial value :	1	1	1	1	1	1	0	0
R/W :	—	—	—	—	—	—	R/W	R/W

SIENR2 controls the permission and prohibition of the interrupt of the servo section. SIENR2 is an 8-bit readable/writable register. It is initialized to HFC by a reset, stand-by or module stop.

**Bits 7 to 2—Reserved:** No read or write is valid. If a read is attempted, an undetermined value is read out.



**Bit 1—Vertical Sync Signal Interrupt Permission Bit (IESNC)****Bit 1**

IESNC	Description
0	Prohibits the interrupt (interrupt to the vertical sync signal) request through IRRSNC (Initial value)
1	Permits the interrupt request through IRRSNC

**Bit 0—CTL Interrupt Permission Bit (IECTL)****Bit 0**

IECTL	Description
0	Prohibits the interrupt request through IRRCTL (Initial value)
1	Permits the interrupt request through IRRCTL

**(3) Servo Interrupt Request Register 1 (SIRQR1)**

Bit :	7	6	5	4	3	2	1	0
	IRRDRM3	IRRDRM2	IRRDRM1	IRRCAP3	IRRCAP2	IRRCAP1	IRRHSW2	IRRHSW1
Initial value :	0	0	0	0	0	0	0	0
R/W :	R/(W)*	R/(W)*	R/(W)*	R/(W)*	R/(W)*	R/(W)*	R/(W)*	R/(W)*

Note: \* Only 0 can be written to clear the flag.

SIRQR1 displays an occurrence of an interrupt request of the servo section. If the interrupt request occurred, the corresponding bit is set to 1.

SIRQR1 is an 8-bit readable/writable register. Writing is allowed only in the case of writing 0 to clear the flag. It is initialized to H'00 by a reset, stand-by or module stop.

**Bit 7—Drum Phase Error Detector Interrupt Request Bit (IRRDRM3)****Bit 7**

IRRDRM3	Description
0	No interrupt request from the drum phase error detector (Initial value)
1	Interrupt requested from the drum phase error detector

**Bit 6—Drum Speed Error Detector (Lock Detection) Interrupt Request Bit (IRRDRM2)****Bit 6**

<b>IRRDRM2</b>	<b>Description</b>
0	No interrupt request from the drum speed error detector (lock detection) (Initial value)
1	Interrupt requested from the drum speed error detector (lock detection)

**Bit 5—Drum Speed Error Detector (OVF, Latch) Interrupt Request Bit (IRRDRM1)****Bit 5**

<b>IRRDRM1</b>	<b>Description</b>
0	No interrupt request from the drum speed error detector (OVF, latch) (Initial value)
1	Interrupt requested from the drum speed error detector (OVF, latch)

**Bit 4—Capstan Phase Error Detector Interrupt Request Bit (IRRCAP3)****Bit 4**

<b>IRRCAP3</b>	<b>Description</b>
0	No interrupt request from the capstan phase error detector (Initial value)
1	Interrupt requested from the capstan phase error detector

**Bit 3—Capstan Speed Error Detector (Lock Detection) Interrupt Request Bit (IRRCAP2)****Bit 3**

<b>IRRCAP2</b>	<b>Description</b>
0	No interrupt request from the capstan speed error detector (lock detection) (Initial value)
1	Interrupt requested from the drum speed error detector (lock detection)

**Bit 2—Capstan Speed Error Detector (OVF, Latch) Interrupt Request Bit (IRRCAP1)****Bit 2**

<b>IRRCAP1</b>	<b>Description</b>
0	No interrupt request from the capstan speed error detector (OVF, latch) (Initial value)
1	Interrupt requested from the capstan speed error detector (OVF, latch)

### Bit 1—HSW Timing Generator (Counter Clear, Capture) Interrupt Permission Bit (IRRHSW2)

#### Bit 1

IRRHSW2	Description
0	No interrupt request from the HSW timing generator (counter clear, capture) (Initial value)
1	Interrupt requested from the HSW timing generator (counter clear, capture)

### Bit 0—HSW Timing Generator (OVW, Matching, STRIG) Interrupt Permission Bit (IRRHSW1)

#### Bit 0

IRRHSW1	Description
0	No interrupt request from the HSW timing generator (OVW, matching, STRIG) (Initial value)
1	Interrupt requested from the HSW timing generator (OVW, matching, STRIG)

### (4) Servo Interrupt Request Register 2 (SIRQR2)

Bit :	7	6	5	4	3	2	1	0
	—	—	—	—	—	—	IRRSNC	IRRCTL
Initial value :	1	1	1	1	1	1	0	0
R/W :	—	—	—	—	—	—	R/(W)*	R/(W)*

Note: \* Only 0 can be written to clear the flag.

SIRQR2 displays an occurrence of an interrupt request of the servo section. If the interrupt request occurred, the corresponding bit is set to 1.

SIRQR2 is an 8-bit readable/writable register. Writing 0 after reading 1 is allowed; no other writing is allowed. It is initialized to H'FC by a reset, stand-by or module stop.

**Bits 7 to 2—Reserved:** No read or write is valid. If a read is attempted, an undetermined value is read out.

**Bit 1—Vertical Sync Signal Interrupt Request Bit (IRRSNC)****Bit 1**

<b>IRRSNC</b>	<b>Description</b>	
0	No interrupt request from the sync signal detector (VD, noise)	(Initial value)
1	Interrupt requested from the sync signal detector (VD, noise)	

---

**Bit 0—CTL Signal Interrupt Request Bit (IRRCTL)****Bit 0**

<b>IRRCTL</b>	<b>Description</b>	
0	No interrupt request from CTL	(Initial value)
1	Interrupt requested from CTL	

---

## 28.17 Module Stop Control Register (MSTPCR)

	MSTPCR <sub>H</sub>								MSTPCR <sub>L</sub>							
Bit :	7	6	5	4	3	2	1	0	7	6	5	4	3	2	1	0
	MSTP15	MSTP14	MSTP13	MSTP12	MSTP11	MSTP10	MSTP9	MSTP8	MSTP7	MSTP6	MSTP5	MSTP4	MSTP3	MSTP2	MSTP1	MSTP0
Initial value :	1	1	1	1	1	1	1	1	1	1	1	1	1	1	1	1
R/W :	R/W	R/W	R/W	R/W	R/W	R/W	R/W	R/W	R/W	R/W	R/W	R/W	R/W	R/W	R/W	R/W

MSTPCR comprises two 8-bit readable/writable registers, that perform module stop mode control. When the MSTP1 bit is set to 1, servo circuit and 12-bit PWM stop the operation at the end of the bus cycle and enter to the module stop mode. For details, see 4.5 Module stop mode.

MSTPCR is initialized to H'FFFF by a reset.

**Bit 1—Module Stop 1 (MSTP1):** This bit specifies module stop mode of the servo circuit and 12-bit PWM.

### MSTPCR<sub>L</sub>

#### Bit 1

MSTP1	Description
0	Clear the module stop mode of the Servo Circuit and 12-bit PWM
1	Set the module stop mode of the Servo Circuit and 12-bit PWM (Initial value)



## Section 29 Electrical Characteristics

### 29.1 Absolute Maximum Ratings

Table 29.1 lists the absolute maximum ratings.

**Table 29.1 Absolute Maximum Ratings**

Item	Symbol	Value	Unit
Power supply voltage	Vcc	-0.3 to +7.0	V
Input voltage (ports other than port 0)	Vin	-0.3 to Vcc +0.3	V
Input voltage (port 0)	Vin	-0.3 to AVcc +0.3	V
A/D converter power supply voltage	AVcc	-0.3 to +7.0	V
A/D converter input voltage	AVin	-0.3 to AVcc +0.3	V
Servo power supply voltage	SVcc	-0.3 to +7.0	V
Servo amplifier input voltage	Vin	-0.3 to SVcc +0.3	V
Operating temperature	Topr	-20 to +75	°C
Operating temperature (At Flash memory program/erase)	Topr	0 to +75	°C
Storage temperature	Tstr	-55 to +125	°C

Notes: 1. Permanent damage may occur to the chip if absolute maximum ratings are exceeded. Normal operation should be under the conditions specified in Electrical Characteristics. Exceeding these values can result in incorrect operation and reduced reliability.

2. All voltages are relative to Vss = SVss = AVss = 0.0 V.

## 29.2 Electrical Characteristics of HD64F2194

### 29.2.1 DC Characteristics of HD64F2194

**Table 29.2 DC Characteristics of HD64F2194 and HD64F2194C**

(Conditions:  $V_{cc} = AV_{cc} = 4.0\text{ V}$  to  $5.5\text{ V}$ ,  $V_{ss} = 0.0\text{ V}$ ,  $T_a = -20$  to  $+75^\circ\text{C}$  unless otherwise specified.)

Item	Symbol	Applicable Pins	Test Conditions	Values			Unit	Notes
				Min	Typ	Max		
Input high voltage	$V_{IH}$	MD0	$V_{cc} = 2.7\text{ V}$ to $5.5\text{ V}$	$0.9 V_{cc}$	—	$V_{cc} + 0.3$	V	
		RES, NMI, FWE, IC, IRQ0 to IRQ5		$0.8 V_{cc}$	—	$V_{cc} + 0.3$		
			$V_{cc} = 2.7\text{ V}$ to $5.5\text{ V}$	$0.9 V_{cc}$	—	$V_{cc} + 0.3$		
		SCK1, SCK2, SI1, SI2, CS, FTIA, FTIB, FTIC, FTID, TRIG, TMBI, ADTRG		$0.8 V_{cc}$	—	$V_{cc} + 0.3$		
		OSC1, X1		$V_{cc} - 0.5$	—	$V_{cc} + 0.3$		
			$V_{cc} = 2.7\text{ V}$ to $5.5\text{ V}$	$V_{cc} - 0.3$	—	$V_{cc} + 0.3$		
		P00 to P07, P10 to P17, P20 to P27, P30 to P37, P40 to P47, P50 to P57, P60 to P67, P70 to P77, P80 to P87, PS0 to PS4		$0.7 V_{cc}$	—	$V_{cc} + 0.3$		
			$V_{cc} = 2.7\text{ V}$ to $5.5\text{ V}$	$0.8 V_{cc}$	—	$V_{cc} + 0.3$		
		Csync		$0.7 V_{cc}$	—	$V_{cc} + 0.3$		



Item	Symbol	Applicable Pins	Test Conditions	Values			Unit	Notes
				Min	Typ	Max		
Input low voltage	$V_{IL}$	MDO	$V_{CC} = 2.7\text{ V to }5.5\text{ V}$	-0.3	—	$0.1 V_{CC}$	V	
		$\overline{RES}$ , $\overline{NMI}$ , FWE, $\overline{IC}$ , $\overline{IRQ0}$ to $\overline{IRQ5}$	$V_{CC} = 2.7\text{ V to }5.5\text{ V}$	-0.3	—	$0.2 V_{CC}$	V	
		SCK1, SCK2, SI1, SI2, $\overline{CS}$ , FTIA, FTIB, FTIC, FTID, TRIG, TMBI, $\overline{ADTRG}$		-0.3	—	$0.2 V_{CC}$	V	
		OSC1, X1		-0.3	—	0.5	V	
			$V_{CC} = 2.7\text{ V to }5.5\text{ V}$	-0.3	—	0.3	V	
		P00 to P07, P10 to P17, P20 to P27, P30 to P37, P40 to P47, P50 to P57, P60 to P67, P70 to P77, P80 to P87, PS0 to PS4	$V_{CC} = 2.7\text{ V to }5.5\text{ V}$	-0.3	—	$0.2 V_{CC}$	V	
		Csync		-0.3	—	$0.2 V_{CC}$	V	
Output high voltage	$V_{OH}$	SO1, SO2, SCK1, SCK2, $-I_{OH} = 1.0\text{ mA}$	$V_{CC}$	—	—	V		
		PWM1, PWM2, PWM3, PWM4, PWM14, STRB, BUZZ, TMO, TMOW, FTOA, FTOB, PPG70 to	$-I_{OH} = 0.5\text{ mA}$	—	$V_{CC}$ -0.5	—	V	Reference value
		PPG77, RP0 to RP7, P10 to P17, P20 to P27, P30 to P37, P40 to P47, P50 to P57, P60 to P67, P70 to P77, P80 to P87, PS0 to PS4	$-I_{OH} = 0.1\text{ mA}$ $V_{CC} = 2.7\text{ V to }5.5\text{ V}$	$V_{CC}$ -0.5	—	—	V	

Item	Symbol	Applicable Pins	Test Conditions	Values			Unit	Notes
				Min	Typ	Max		
Output low voltage	$V_{OL}$	SO1, SO2, SCK1, SCK2, PWM1, PWM2, PWM3, PWM4, PWM14, STRB, BUZZ, TMO, TMOW, FTOA, FTOB, PPG70 to PPG77, RP0 to RP7, P10 to P17, P20 to P27, P30 to P37, P40 to P47, P50 to P57, P60 to P67, P70 to P77, PS0 to PS4	$I_{OL} = 1.6 \text{ mA}$	—	—	0.6	V	
			$I_{OL} = 0.4 \text{ mA}$	—	—	0.4		
			$V_{CC} = 2.7 \text{ V to } 5.5 \text{ V}$					
			$I_{OL} = 20 \text{ mA}$	—	—	1.5		
			$I_{OL} = 1.6 \text{ mA}$	—	—	0.6		
			$I_{OL} = 0.4 \text{ mA}$	—	—	0.4		
			$V_{CC} = 2.7 \text{ V to } 5.5 \text{ V}$					
Input/output leakage current	$I_{IL}$	MD0, OSC1 $\overline{\text{RES}}$ , $\overline{\text{NMI}}$ , FWE, $\overline{\text{IRQ0}}$ to $\overline{\text{IRQ5}}$ , $\overline{\text{IC}}$	$V_{in} = 0.5 \text{ V to } V_{CC} - 0.5 \text{ V}$	—	—	1.0	$\mu\text{A}$	
			$V_{in} = 0.5 \text{ to } V_{CC} - 0.5 \text{ V}$	—	—	1.0		
			$V_{in} = 0.5 \text{ to } V_{CC} - 0.5 \text{ V}$	—	—	1.0		
			$V_{in} = 0.5 \text{ to } V_{CC} - 0.5 \text{ V}$	—	—	1.0		
			$V_{in} = 0.5 \text{ to } AV_{CC} - 0.5 \text{ V}$	—	—	1.0		

Item	Symbol	Applicable Pins	Test Conditions	Values			Unit	Notes
				Min	Typ	Max		
Pull-up MOS current	$-I_p$	P10 to P17, P20 to P27, P30 to P37,	$V_{cc} = 5.0\text{ V}$ , $V_{in} = 0\text{ V}$	50	—	300	$\mu\text{A}$	Note 1
Input capacitance	$C_{in}$	All input pins except power supply, P13, P23, P24 and analog system pins	$f_{in} = 1\text{ MHz}$ , $V_{in} = 0\text{ V}$ , $T_a = 25\text{ }^\circ\text{C}$	—	—	15	pF	
		P13, P23, P24	$f_{in} = 1\text{ MHz}$ , $V_{in} = 0\text{ V}$ , $T_a = 25\text{ }^\circ\text{C}$	—	—	20		
Active mode current dissipation (CPU operating)	$I_{OPE}$	$V_{cc}$	$V_{cc} = 5\text{ V}$ , $f_{OSC} = 10\text{-MHz}$ , High-speed mode	—	50	70	mA	Note 2
			$V_{cc} = 5\text{ V}$ , $f_{OSC} = 10\text{-MHz}$ , Medium-speed mode (1/64)	—	35	—		
Active mode current dissipation (reset)	$I_{RES}$	$V_{cc}$	$V_{cc} = 5\text{ V}$ , $f_{OSC} = 10\text{ MHz}$	—	30	45	mA	Note 2
Sleep mode current dissipation	$I_{SLEEP}$	$V_{cc}$	$V_{cc} = 5\text{ V}$ , $f_{OSC} = 10\text{-MHz}$ High-speed mode	—	20	30		
Subactive mode current dissipation	$I_{SUB}$	$V_{cc}$	$V_{cc} = 2.7\text{ V}$ , With 32-kHz crystal oscillator ( $\phi_{sub} = \phi_w/2$ )	—	90	150	$\mu\text{A}$	Note 2
			$V_{cc} = 2.7\text{ V}$ , With 32-kHz crystal oscillator ( $\phi_{sub} = \phi_w/8$ )	—	40	—		
Subsleep mode current dissipation	$I_{SUBSLP}$	$V_{cc}$	$V_{cc} = 2.7\text{ V}$ , With 32-kHz crystal oscillator ( $\phi_{sub} = \phi_w/2$ )	—	15	30	$\mu\text{A}$	Note 2
			$V_{cc} = 2.7\text{ V}$ , With 32-kHz crystal oscillator ( $\phi_{sub} = \phi_w/8$ )	—	10	—		

Item	Symbol	Applicable Pins	Test Conditions	Values			Unit	Notes
				Min	Typ	Max		
Watch mode current dissipation	$I_{WATCH}$	Vcc	Vcc = 2.7 V, With 32-kHz crystal oscillator	—	5	10	$\mu\text{A}$	Note 2
			Vcc = 5.0 V, With 32-kHz crystal oscillator	—	10	—		
Standby mode current dissipation	$I_{STBY}$	Vcc	X1 = Vcc, Without 32-kHz crystal oscillator	—	—	5		Note 2
RAM data retaining voltage in standby mode	$V_{STBY}$			2.0	—	—	V	

Notes: Do not open the AVcc and AVss pin even when the A/D converter is not in use.

1. Current value when the relevant bit of the pull-up MOS select register (PUR1 to PUR3) is set to 1.
2. The current on the pull-up MOS or the output buffer excluded.

**Table 29.3 Pin Status at Current Dissipation Measurement**

Mode	RES pin	Internal State	Pin	Oscillator Pin
Active mode High-speed, medium-speed	Vcc	Operating	Vcc	Main clock: Crystal oscillator Sub clock: X1 pin = Vcc
Sleep mode High-speed, medium-speed	Vcc	CPU and servo circuits stopped.	Vcc	
Reset	Vss	Reset	Vcc	
Standby mode	Vcc	All stopped	Vcc	
Subactive mode	Vcc	CPU and timer A operating	Vcc	Main clock: Crystal oscillator Sub clock: Crystal oscillator
Subsleep mode	Vcc	Timer A operating	Vcc	
Watch mode	Vcc	Timer A operating	Vcc	

**Table 29.4 Bus Drive Characteristics of HD64F2194 and HD64F2194C**

(Conditions:  $V_{CC} = AV_{CC} = 4.0\text{ V to }5.5\text{ V}$ ,  $V_{SS} = 0.0\text{ V}$ ,  $T_a = -20\text{ to }+75^\circ\text{C}$  unless otherwise specified.) Applicable pin: SCL, SDA

Item	Symbol	Applicable Test Pins	Test Conditions	Values			Unit
				Min	Typ	Max	
Schmidt trigger input voltage	$V_T^-$	SCL, SDA		0.2 $V_{CC}$	—	—	V
	$V_T^+$			—	—	0.7 $V_{CC}$	V
	$V_T^+$			0.05 $V_{CC}$	—	—	V
	$-V_T^-$						
Input High voltage	$V_{IH}$	SCL, SDA		0.7 $V_{CC}$	—	$V_{CC} + 0.5$	V
Input Low voltage	$V_{IL}$	SCL, SDA		-0.5	—	0.2 $V_{CC}$	V
Output Low voltage	$V_{OL}$	SCL, SDA	$I_{OL} = 8\text{ mA}$	—	—	0.5	V
			$I_{OL} = 3\text{ mA}$	—	—	0.4	
SCL and SDA output $t_{of}$ fall time		SCL, SDA		20 + 0.1Cb	—	250	ns

### 29.2.2 Allowable Output Currents of HD64F2194 and HD64F2194C

The specifications for the digital pins are shown below.

**Table 29.5 Allowable Output Currents of HD64F2194 and HD64F2194C**

(Conditions:  $V_{cc} = 2.7\text{ V to }5.5\text{ V}$ ,  $V_{ss} = 0.0\text{ V}$ ,  $T_a = -20\text{ to }+75^\circ\text{C}$ )

Item	Symbol	Value	Unit	Notes
Allowable input current (to chip)	$I_o$	2	mA	1
Allowable input current (to chip)	$I_o$	22	mA	2
Allowable input current (to chip)	$I_o$	10	mA	3
Allowable output current (from chip)	$-I_o$	2	mA	4
Total allowable input current (to chip)	$\Sigma I_o$	80	mA	5
Total allowable output current (from chip)	$-\Sigma I_o$	50	mA	6

- Notes:
1. The allowable input current is the maximum value of the current flowing from each I/O pin to  $V_{ss}$  (except for port 8, SCL and SDA).
  2. The allowable input current is the maximum value of the current flowing from each I/O pin to  $V_{ss}$ . This applies to port 8.
  3. The allowable input current is the maximum value of the current flowing from each I/O pin to  $V_{ss}$ . This applies to SCL and SDA.
  4. The allowable output current is the maximum value of the current flowing from  $V_{cc}$  to each I/O pin.
  5. The total allowable input current is the sum of the currents flowing from all I/O pins to  $V_{ss}$  simultaneously.
  6. The total allowable output current is the sum of the currents flowing from  $V_{cc}$  to all I/O pins.

## 29.2.3 AC Characteristics of HD64F2194 and HD64F2194C

Table 29.6 AC Characteristics of HD64F2194 and HD64F2194C

(Conditions:  $V_{CC} = AV_{CC} = 4.0\text{ V}$  to  $5.5\text{ V}$ ,  $V_{SS} = AV_{SS} = 0.0\text{ V}$ ,  $T_a = -20$  to  $+75^\circ\text{C}$  unless otherwise specified.)

Item	Symbol	Applicable Pins	Test Conditions	Values			Unit	Notes
				Min	Typ	Max		
Clock oscillation frequency	$f_{OSC}$	OSC1, OSC2		8	—	10	MHz	
Clock cycle time	$t_{cyc}$	OSC1, OSC2		100	—	125	ns	Figure 29.1
Subclock oscillation frequency	$f_x$	X1, X2	$V_{CC} = 2.7\text{ V}$ to $5.5\text{ V}$	—	32.768	—	kHz	
Subclock cycle time	$t_{subcyc}$	X1, X2	$V_{CC} = 2.7\text{ V}$ to $5.5\text{ V}$	—	30.518	—	$\mu\text{s}$	Figure 29.2
Oscillation stabilization time	$t_{rc}$	OSC1, OSC2	Crystal oscillator	—	—	10	ms	
		X1, X2	32-kHz crystal oscillator $V_{CC} = 2.7\text{ V}$ to $5.5\text{ V}$	—	—	2	s	
External clock high width	$t_{CPH}$	OSC1		40	—	—	ns	Figure 29.1
External clock low width	$t_{CPL}$	OSC1		40	—	—	ns	
External clock rise time	$t_{CPr}$	OSC1		—	—	10	ns	
External clock fall time	$t_{CPf}$	OSC1		—	—	10	ns	
External clock stabilization delay time	$t_{DEXT}$	OSC1		500	—	—	$\mu\text{s}$	Figure 29.3
Subclock input low level pulse width	$t_{EXCLL}$	X1	$V_{CC} = 2.7\text{ V}$ to $5.5\text{ V}$	—	15.26	—	$\mu\text{s}$	Figure 29.2
Subclock input high level pulse width	$t_{EXCLH}$	X1	$V_{CC} = 2.7\text{ V}$ to $5.5\text{ V}$	—	15.26	—	$\mu\text{s}$	

Item	Symbol	Applicable Pins	Test Conditions	Values			Unit	Notes
				Min	Typ	Max		
Subclock input rise time	$t_{EXCLr}$	X1	$V_{CC} = 2.7\text{ V to } 5.5\text{ V}$	—	—	10	ns	Figure 29.2
Subclock input fall time	$t_{EXCLf}$	X1	$V_{CC} = 2.7\text{ V to } 5.5\text{ V}$	—	—	10	ns	
$\overline{\text{RES}}$ pin low level width	$t_{REL}$	$\overline{\text{RES}}$	$V_{CC} = 2.7\text{ V to } 5.5\text{ V}$	20	—	—	$t_{cyc}$	Figure 29.4
Input pin high level width	$t_{IH}$	$\overline{\text{IRQ0}}$ to $\overline{\text{IRQ5}}$ , $\overline{\text{NMI}}$ , $\overline{\text{IC}}$ , $\overline{\text{ADTRG}}$ , $\overline{\text{TMBI}}$ , $\overline{\text{FTIA}}$ , $\overline{\text{FTIB}}$ , $\overline{\text{FTIC}}$ , $\overline{\text{FTID}}$ , $\overline{\text{TRIG}}$	$V_{CC} = 2.7\text{ V to } 5.5\text{ V}$	2	—	—	$t_{cyc}$ $t_{subcyc}$	Figure 29.5
Input pin low level width	$t_{IL}$	$\overline{\text{IRQ0}}$ to $\overline{\text{IRQ5}}$ , $\overline{\text{NMI}}$ , $\overline{\text{IC}}$ , $\overline{\text{ADTRG}}$ , $\overline{\text{TMBI}}$ , $\overline{\text{FTIA}}$ , $\overline{\text{FTIB}}$ , $\overline{\text{FTIC}}$ , $\overline{\text{FTID}}$ , $\overline{\text{TRIG}}$	$V_{CC} = 2.7\text{ V to } 5.5\text{ V}$	2	—	—	$t_{cyc}$ $t_{subcyc}$	

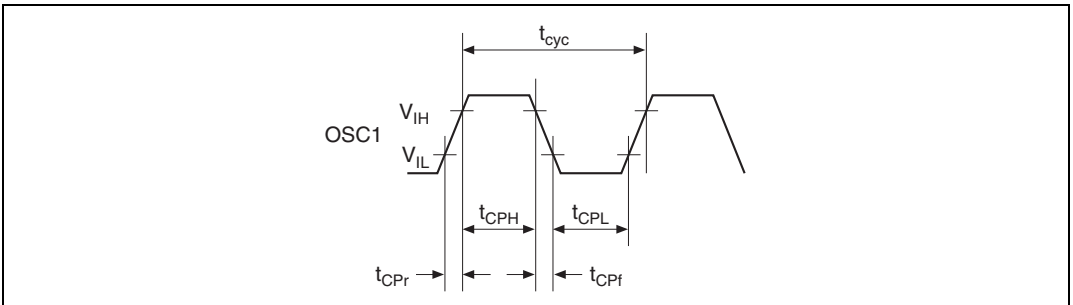
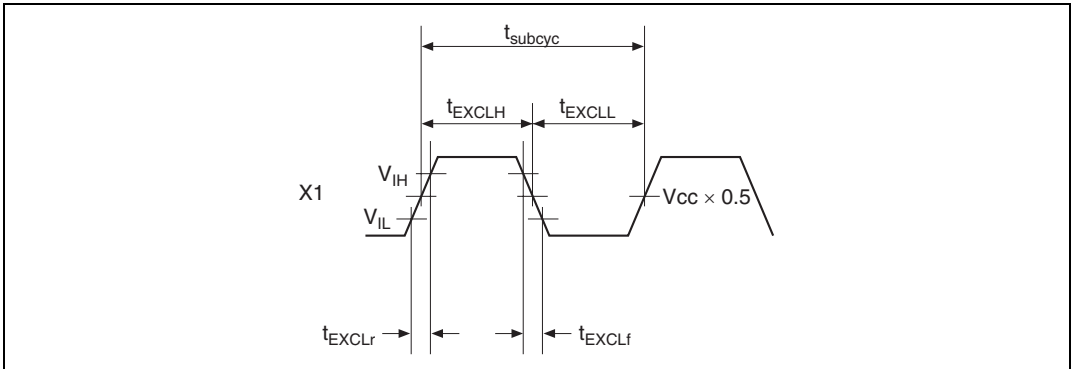
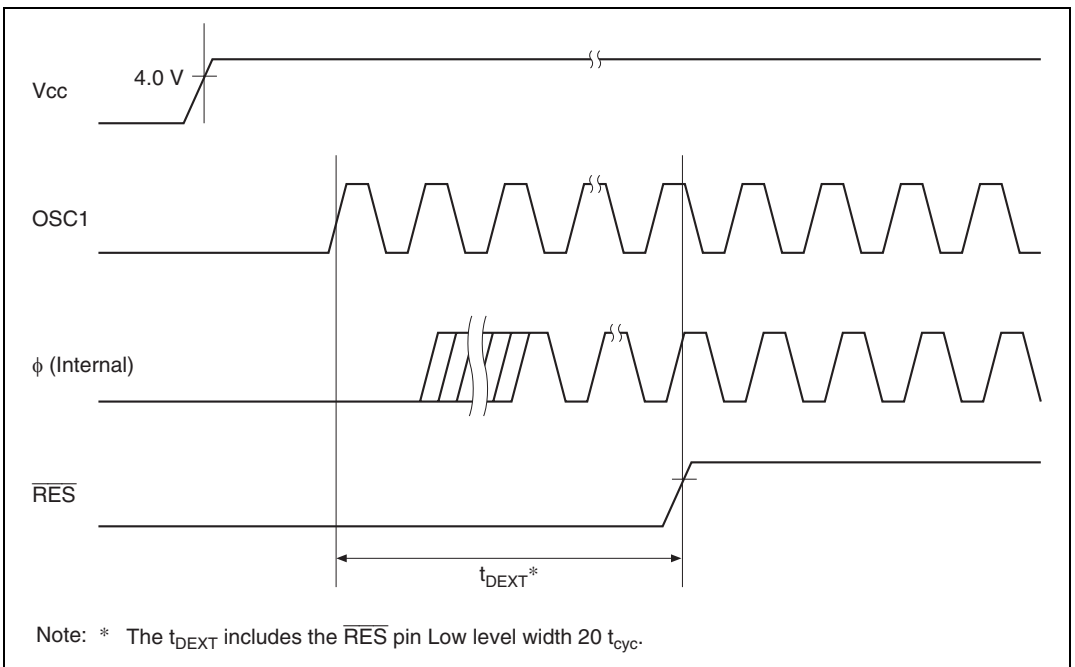


Figure 29.1 System Clock Timing

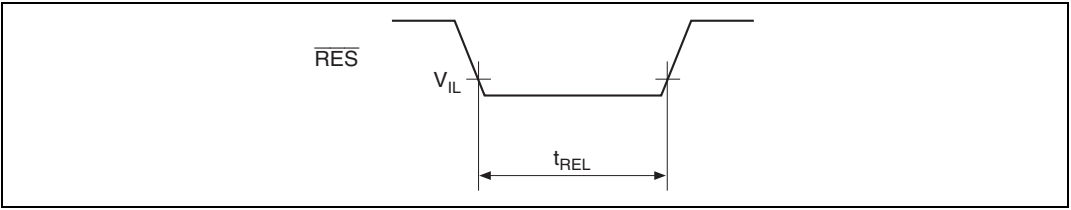




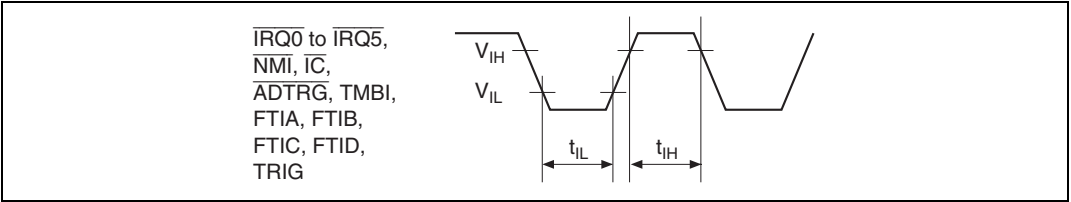
**Figure 29.2 Subclock Input Timing**



**Figure 29.3 External Clock Stabilization Delay Timing**



**Figure 29.4 Reset Input Timing**



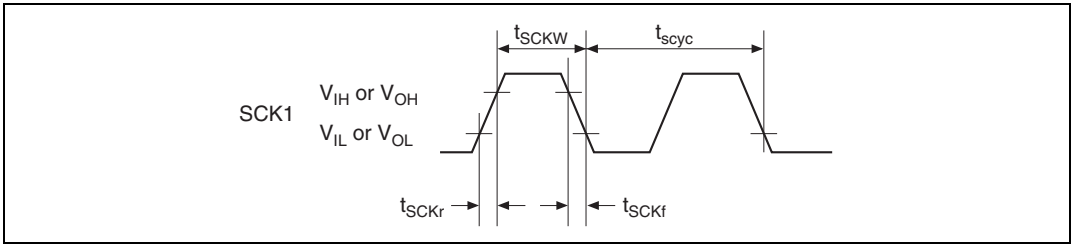
**Figure 29.5 Input Timing**

## 29.2.4 Serial Interface Timing of HD64F2194 and HD64F2194C

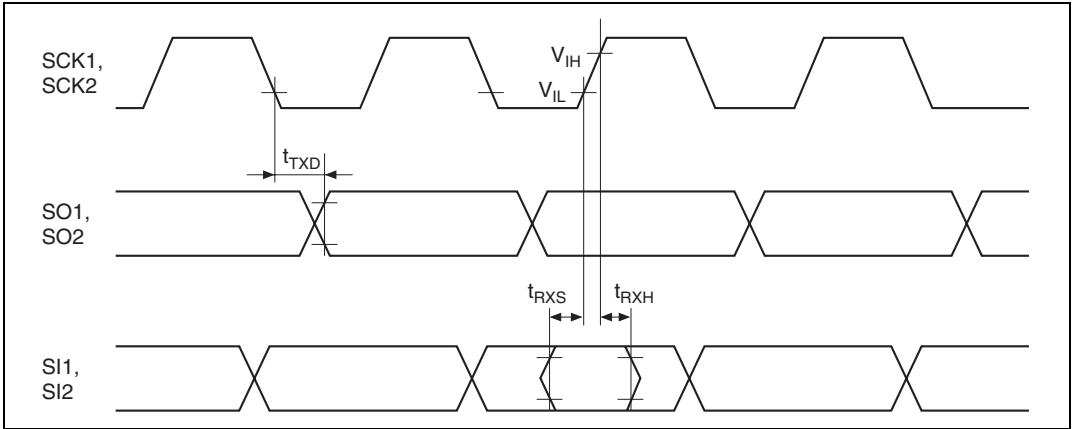
Table 29.7 Serial Interface Timing of HD64F2194 and HD64F2194C

(Conditions:  $V_{cc} = AV_{cc} = 4.0\text{ V to }5.5\text{ V}$ ,  $V_{ss} = AV_{ss} = 0.0\text{ V}$ ,  $T_a = -20\text{ to }+75^\circ\text{C}$  unless otherwise specified.)

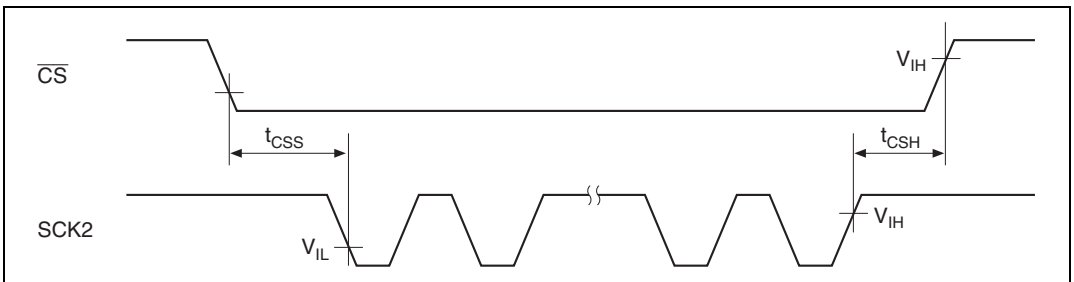
Item	Symbol	Applicable Test Pins	Test Conditions	Values			Unit	Figure
				Min	Typ	Max		
Input clock cycle	$t_{scyc}$	SCK1	Asynchroniza- tion	4	—	—	$t_{cyc}$	Figure 29.6
			Clock synchronization	6	—	—		
		SCK2	2	—	—			
Input clock pulse width	$t_{SCKW}$	SCK1, SCK2		0.4	—	0.6	$t_{scyc}$	
Input clock rise time	$t_{SCKr}$	SCK1		—	—	1.5	$t_{cyc}$	
		SCK2		—	—	60	ns	
Input clock fall time	$t_{SCKf}$	SCK1		—	—	1.5	$t_{cyc}$	
		SCK2		—	—	60	ns	
Transmit data delay time (clock sync)	$t_{TXD}$	SO1		—	—	100	ns	Figure 29.7
Receive data setup time (clock sync)	$t_{RXS}$	SI1		100	—	—	ns	
Receive data hold time (clock sync)	$t_{RXH}$	SI1		100	—	—	ns	
Transmit data output delay time	$t_{TXD}$	SO2		—	—	200	ns	Figure 29.7
Receive data setup time (clock sync)	$t_{RXS}$	SI2		180	—	—	ns	
Receive data hold time (clock sync)	$t_{RXH}$	SI2		180	—	—	ns	
$\overline{CS}$ setup time	$t_{CSS}$	$\overline{CS}$		1	—	—	$t_{scyc}$	Figure 29.8
$\overline{CS}$ hold time	$t_{CSH}$	$\overline{CS}$		1	—	—	$t_{scyc}$	



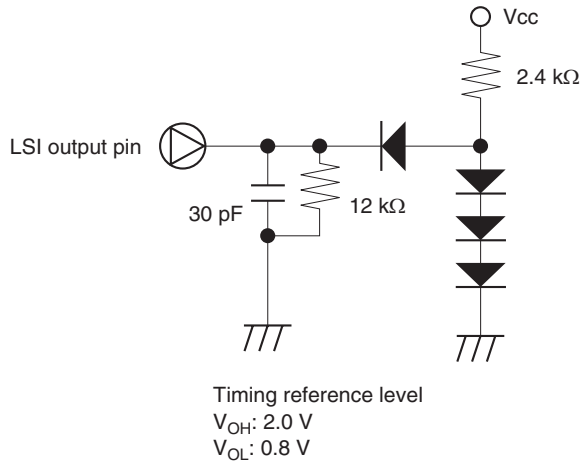
**Figure 29.6 SCK1 Clock Timing**



**Figure 29.7 SCI I/O Timing/Clock Synchronization Mode**



**Figure 29.8 SCI2 Chip Select Timing**

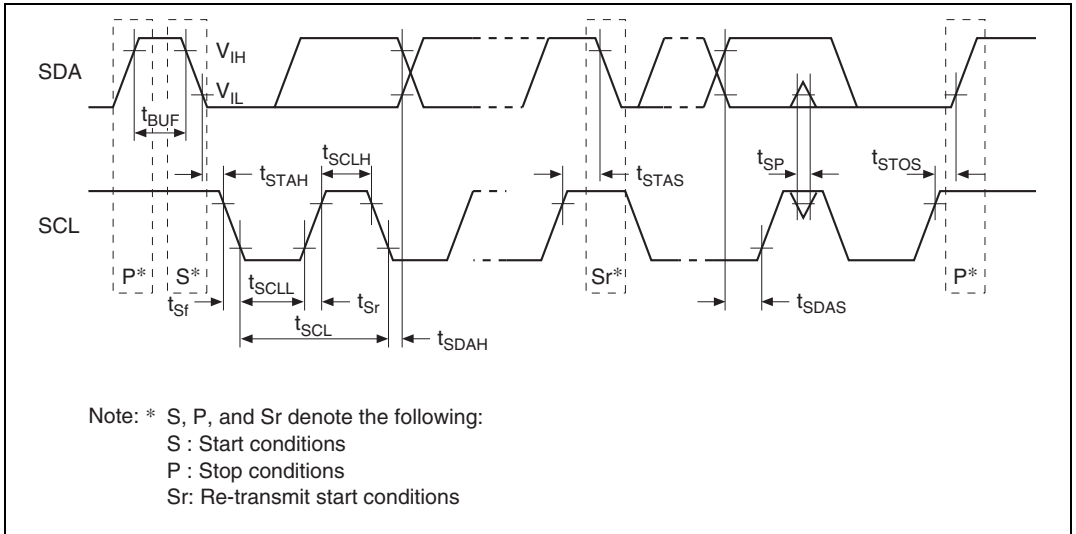
**Figure 29.9 Output Load Conditions**

**Table 29.8 I<sup>2</sup>C Bus Interface Timing of HD64F2194 and HD64F2194C**

(Conditions:  $V_{CC} = AV_{CC} = 4.0\text{ V to }5.5\text{ V}$ ,  $V_{SS} = AV_{SS} = 0.0\text{ V}$ ,  $T_a = -20\text{ to }+75^\circ\text{C}$  unless otherwise specified.)

Item	Symbol	Test Conditions	Values			Unit	Figure
			Min	Typ	Max		
SCL input cycle time	$t_{SCL}$		12	—	—	$t_{cyc}$	Figure 29.10
SCL input high pulse width	$t_{SCLH}$		3	—	—	$t_{cyc}$	
SCL input low pulse width	$t_{SCLL}$		5	—	—	$t_{cyc}$	
SCL, SDA input rise time	$t_{sr}$		—	—	7.5*	$t_{cyc}$	
SCL, SDA input fall time	$t_{sf}$		—	—	300	ns	
SCL, SDA input spike pulse removal time	$t_{sp}$		—	—	1	$t_{cyc}$	
SDA input bus free time	$t_{BUF}$		5	—	—	$t_{cyc}$	
Start condition input hold time	$t_{STAH}$		3	—	—	$t_{cyc}$	
Re-transmit start condition input setup time	$t_{STAS}$		3	—	—	$t_{cyc}$	
Stop condition input setup time	$t_{STOS}$		3	—	—	$t_{cyc}$	
Data input setup time	$t_{SDAS}$		0.5	—	—	$t_{cyc}$	
Data input hold time	$t_{SDAH}$		0	—	—	ns	
SCL, SDA capacity load	$C_b$		—	—	400	pF	

Note: \* Can also be set to  $17.5 t_{cyc}$  depending on the selection of clock to be used by the I<sup>2</sup>C module.



**Figure 29.10 I<sup>2</sup>C Bus Interface I/O Timing**

## 29.2.5 A/D Converter Characteristics of HD64F2194 and HD64F2194C

Table 29.9 A/D Converter Characteristics of HD64F2194 and HD64F2194C

(Conditions:  $V_{CC} = AV_{CC} = 4.0\text{ V}$  to  $5.5\text{ V}$ ,  $V_{SS} = AV_{SS} = 0.0\text{ V}$ ,  $T_a = -20$  to  $+75^\circ\text{C}$  unless otherwise specified.)

Item	Symbol	Applicable Pins	Test Conditions	Values			Unit
				Min	Typ	Max	
Analog power supply voltage	$AV_{CC}$	$AV_{CC}$		$V_{CC} - 0.3$	$V_{CC}$	$V_{CC} + 0.3$	V
Analog input voltage	$A_{VIN}$	AN0 to AN7, AN8 to ANB		$AV_{SS}$	—	$AV_{CC}$	V
Analog power supply current	$A_{ICC}$	$AV_{CC}$	$AV_{CC} = 5.0\text{ V}$	—	—	2.0	mA
	$A_{ISTOP}$	$AV_{CC}$	$V_{CC} = 2.7$ to $5.5\text{ V}$ , at reset and in power-down mode	—	—	10	$\mu\text{A}$
Analog input capacitance	$C_{AIN}$	AN0 to AN7, AN8 to ANB		—	—	30	pF
Allowable signal source impedance	$R_{AIN}$	AN0 to AN7, AN8 to ANB		—	—	10	$\text{k}\Omega$
Resolution				—	—	10	Bit
Absolute accuracy			$AV_{CC} = 5.0\text{ V}$	—	—	$\pm 4$	LSB
Conversion time				13.4	—	26.6	$\mu\text{s}$

Note: Do not open the  $AV_{CC}$  and  $AV_{SS}$  pin even when the A/D converter is not in use. Set  $AV_{CC} = V_{CC}$  and  $AV_{SS} = V_{SS}$ .



## 29.2.6 Servo Section Electrical Characteristics of HD64F2194 and HD64F2194C

Table 29.10 Servo Section Electrical Characteristics of HD64F2194 and HD64F2194C  
(Reference Values)(Conditions:  $V_{cc} = SV_{cc} = 5.0\text{ V}$ ,  $V_{ss} = SV_{ss} = 0.0\text{ V}$ ,  $T_a = 25^\circ\text{C}$  unless otherwise specified.)

Item	Applicable Symbol Pins	Test Conditions	Reference Values			Unit
			Min	Typ	Max	
PB-CTL input amplifier voltage gain	CTL (+)	CTLGR3 = 0, CTLGR2 = 0, CTLGR1 = 0, CTLGR0 = 0, f = 10 kHz	32.0	34.0	36.0	dB
		CTLGR3 = 0, CTLGR2 = 0, CTLGR1 = 0, CTLGR0 = 1, f = 10 kHz	34.5	36.5	38.5	
		CTLGR3 = 0, CTLGR2 = 0, CTLGR1 = 1, CTLGR0 = 0, f = 10 kHz	37.0	39.0	41.0	
		CTLGR3 = 0, CTLGR2 = 0, CTLGR1 = 1, CTLGR0 = 1, f = 10 kHz	39.5	41.5	43.5	
		CTLGR3 = 0, CTLGR2 = 1, CTLGR1 = 0, CTLGR0 = 0, f = 10 kHz	42.0	44.0	46.0	
		CTLGR3 = 0, CTLGR2 = 1, CTLGR1 = 0, CTLGR0 = 1, f = 10 kHz	44.5	46.5	48.5	
		CTLGR3 = 0, CTLGR2 = 1, CTLGR1 = 1, CTLGR0 = 0, f = 10 kHz	47.0	49.0	51.0	
		CTLGR3 = 0, CTLGR2 = 1, CTLGR1 = 1, CTLGR0 = 1, f = 10 kHz	49.5	51.5	53.5	
		CTLGR3 = 1, CTLGR2 = 0, CTLGR1 = 0, CTLGR0 = 0, f = 10 kHz	52.0	54.0	56.0	
		CTLGR3 = 1, CTLGR2 = 0, CTLGR1 = 0, CTLGR0 = 1, f = 10 kHz	54.5	56.5	58.5	
		CTLGR3 = 1, CTLGR2 = 0, CTLGR1 = 1, CTLGR0 = 0, f = 10 kHz	57.0	59.0	61.0	
		CTLGR3 = 1, CTLGR2 = 0, CTLGR1 = 1, CTLGR0 = 1, f = 10 kHz	59.5	61.5	63.5	
		CTLGR3 = 1, CTLGR2 = 1, CTLGR1 = 0, CTLGR0 = 0, f = 10 kHz	62.0	64.0	66.0	
		CTLGR3 = 1, CTLGR2 = 1, CTLGR1 = 0, CTLGR0 = 1, f = 10 kHz	64.5	66.5	68.5	
CTLGR3 = 1, CTLGR2 = 1, CTLGR1 = 1, CTLGR0 = 0, f = 10 kHz	67.0	69.0	71.0			
CTLGR3 = 1, CTLGR2 = 1, CTLGR1 = 1, CTLGR0 = 1, f = 10 kHz	69.5	71.5	73.5			

Item	Symbol	Applicable Pins	Test Conditions	Reference Values			Unit
				Min	Typ	Max	
PB-CTL Schmidt input	V+TH	CTLSMT (i)	AC coupling, C = 0.1 $\mu$ F Typ (non pol)	—	250	—	mVp
	V-TH			—	-250	—	
Analog switch ON resistance	REB			—	150	—	$\Omega$
REC-CTL output current	ICTL	CTL (+)	Series resistance = 0 $\Omega$	—	8	—	mA
		CTL (-)		—	8	—	
REC-CTL inter-pin resistance	RCTL			—	10	—	k $\Omega$
CTL reference output voltage		CTLREF		—	1/2 SV <sub>cc</sub>	—	V
CFG pin bias voltage		CFG		—	1/2 SV <sub>cc</sub>	—	V
CFG input level		CFG	AC coupling, C = 1 $\mu$ F Typ, f = 1 kHz	1.0	—	—	V <sub>pp</sub>
CFG input impedance		CFG		—	10	—	k $\Omega$
CFG input threshold voltage	V+THCF	CFG	Rise threshold level	—	2.25	—	V
	V-THCF		Fall threshold level	—	2.75	—	
DFG Schmidt input	V+THDF	DFG	Rising edge Schmidt level	—	1.95	—	V
	V-THDF		Falling edge Schmidt level	—	1.85	—	
DPG Schmidt input	V+THDP	DPG	Rising edge Schmidt level	—	3.55	—	V
	V-THDP		Falling edge Schmidt level	—	3.45	—	
3-level output voltage	V <sub>OH</sub>	Vpulse	-I <sub>OH</sub> = 0.1 mA	4.0	—	—	V
	V <sub>OM</sub>		No load, Hi-Z = 1	—	2.5	—	
	V <sub>OL</sub>		I <sub>OL</sub> = 0.1 mA	—	—	1.0	
3-level output pin divided voltage resistance		Vpulse		—	15	—	k $\Omega$
CFG Duty		CFG	AC coupling, C = 1 $\mu$ F Typ, f = 1 kHz	48	—	52	%

**Table 29.11 Servo Section Electrical Characteristics of HD64F2194 and HD64F2194C**(Conditions:  $V_{CC} = SV_{CC} = 5.0\text{ V}$ ,  $V_{SS} = SV_{SS} = 0.0\text{ V}$ ,  $T_a = 25^\circ\text{C}$  unless otherwise specified.)

Item	Symbol	Applicable Pins	Test Conditions	Values			Unit
				Min	Typ	Max	
Digital input high voltage	$V_{IH}$	COMP, EXCTL, EXCAP, EXTTRG		0.8 $V_{CC}$	—	$V_{CC}$ +0.3	V
Digital input low voltage	$V_{IL}$			-0.3	—	0.2 $V_{CC}$	
Digital output high voltage	$V_{OH}$	H.AmpSW, C.Rotary,	$-I_{OH} = 1\text{ mA}$	$V_{CC}$ -1.0	—	—	V
Digital output low voltage	$V_{OL}$	VIDEOFF, AUDIOFF, DRMPWM, CAPPWM, SV1, SV2	$I_{OL} = 1.6\text{ mA}$	—	—	0.6	
Current dissipation	$I_{CCSV}$	$SV_{CC}$	At no load	—	5	10	mA

### 29.2.7 FLASH Memory Characteristics

Table 29.12 shows the flash memory characteristics.

**Table 29.12 Flash Memory Characteristics (Preliminary)**

Conditions:  $V_{CC} = 5.0\text{ V} \pm 10\%$ ,  $AV_{CC} = 5.0\text{ V} \pm 10\%$ ,  $V_{SS} = AV_{SS} = 0\text{ V}$ ,  $T_a = 0$  to  $+75^\circ\text{C}$   
(operating temperature range at programming/erasing)

Item	Symbol	Min	Typ	Max	Unit	Test Conditions
Programming time <sup>*1*2*4</sup>	$t_p$	—	10	200	ms/ 32 bytes	
Erasing time <sup>*1*3*5</sup>	$t_E$	—	100	1200	ms/ block	
Reprogramming count	$N_{WEC}$	100 <sup>*7</sup>	10000 <sup>*8</sup>	—	Times	
Data retention time <sup>*9</sup>	$t_{DRP}$	10	—	—	Years	
At Programming	Wait time after SWE-bit setting <sup>*1</sup>	10	—	—	$\mu\text{s}$	—
	Wait time after PSU-bit setting <sup>*1</sup>	50	—	—	$\mu\text{s}$	—
	Wait time after P-bit setting <sup>*1*4</sup>	150	—	200	$\mu\text{s}$	200
	Wait time after P-bit clearing <sup>*1</sup>	10	—	—	$\mu\text{s}$	—
	Wait time after PSU-bit clearing <sup>*1</sup>	10	—	—	$\mu\text{s}$	—
	Wait time after PV-bit setting <sup>*1</sup>	4	—	—	$\mu\text{s}$	—
	Wait time after dummy write <sup>*1</sup>	2	—	—	$\mu\text{s}$	—
	Wait time after PV-bit clearing <sup>*1</sup>	4	—	—	$\mu\text{s}$	—
	Maximum No. of programmings <sup>*1*4*5</sup>	—	—	1000	Times	1000
At Erasing	Wait time after SWE-bit setting <sup>*1</sup>	10	—	—	$\mu\text{s}$	—
	Wait time after ESU-bit setting <sup>*1</sup>	200	—	—	$\mu\text{s}$	—
	Wait time after E-bit setting <sup>*1*6</sup>	5	—	10	ms	10
	Wait time after E-bit clearing <sup>*1</sup>	10	—	—	$\mu\text{s}$	—
	Wait time after ESU-bit clearing <sup>*1</sup>	10	—	—	$\mu\text{s}$	—
	Wait time after EV-bit setting <sup>*1</sup>	20	—	—	$\mu\text{s}$	—
	Wait time after dummy write <sup>*1</sup>	2	—	—	$\mu\text{s}$	—
	Wait time after EV-bit clearing <sup>*1</sup>	5	—	—	$\mu\text{s}$	—
	Maximum No. of erasings <sup>*1*6</sup>	120	—	240	Times	240

- Notes:
1. Perform each time setting according to the programming/erasing algorithm.
  2. Programming time per 32 bytes (total time of setting P-bit of the flash memory control register. Programming verify time is not included).
  3. Time to erase 1 block (total time of setting E-bit of the flash memory control register. Erasing verify time is not included).
  4. Maximum programming time ( $t_p$  (max.)) = Wait time after P-bit setting (z) × Maximum No. of programming (N)
  5. No. of times when wait time after P-bit setting (z) = 200  $\mu$ s. Set maximum No. of programming shall be set less than maximum programming time ( $t_p$  (max.)) according to the actual setting (z).
  6. Relationship between wait time after E-bit setting (z) and maximum No. of erasing (N) for maximum erasing time ( $t_e$  (max.)) is as follows:  
 $t_e$  (max.) = Wait time after E-bit setting × Maximum No. of erasing (N)  
 Set the (z) and (N) values so that they satisfy the above equation.  
 (Ex.) When z = 5 [ms], N = 240 times  
 (Ex.) When z = 10 [ms], N = 120 times
  7. Minimum number of times for which all characteristics are guaranteed after rewriting (Guarantee range is 1 to minimum value).
  8. Reference value for 25°C (as a guideline, rewriting should normally function up to this value).
  9. Data retention characteristic when rewriting is performed within the specification range, including the minimum value.

### 29.2.8 Usage Note

The F-ZTAT version and the Mask ROM version satisfy the electrical characteristics indicated in this manual, but the actual power value, operating margin, and noise margin may differ from those in this manual, due to the difference of production process, on-chip ROM, layout pattern, etc. When executing the system examination using the F-ZTAT version, be sure to execute the same system examination using the Mask ROM version when changing to the Mask ROM version.

## 29.3 Electrical Characteristics of HD6432194, HD6432193, HD6432192, HD6432191, HD6432194C, HD6432194B, and HD6432194A

### 29.3.1 DC Characteristics of HD6432194, HD6432193, HD6432192, HD6432191, HD6432194C, HD6432194B, and HD6432194A

**Table 29.13 DC Characteristics of HD6432194, HD6432193, HD6432192, HD6432191, HD6432194C, HD6432194B, and HD6432194A**

(Conditions:  $V_{cc} = AV_{cc} = 4.0\text{ V to }5.5\text{ V}$ ,  $V_{ss} = AV_{ss} = 0.0\text{ V}$ ,  $T_a = -20\text{ to }+75^\circ\text{C}$  unless otherwise specified.)

Item	Symbol	Applicable Pins	Test Conditions	Values			Unit	Notes
				Min	Typ	Max		
Input high voltage	$V_{IH}$	MD0	$V_{cc} = 2.5\text{ V to }5.5\text{ V}$	$0.9 V_{cc}$	—	$V_{cc} + 0.3$	V	
		$\overline{RES}$ , $\overline{NMI}$ , $\overline{IC}$ , $\overline{IRQ0}$ to $\overline{IRQ5}$		$0.8 V_{cc}$	—	$V_{cc} + 0.3$		
			$V_{cc} = 2.5\text{ V to }5.5\text{ V}$	$0.9 V_{cc}$	—	$V_{cc} + 0.3$		
		SCK1, SCK2, SI1, SI2, $\overline{CS}$ , FTIA, FTIB, FTIC, FTID, TRIG, TMBI, $\overline{ADTRG}$		$0.8 V_{cc}$	—	$V_{cc} + 0.3$		
		OSC1, X1		$V_{cc} - 0.5$	—	$V_{cc} + 0.3$		
			$V_{cc} = 2.5\text{ V to }5.5\text{ V}$	$V_{cc} - 0.3$	—	$V_{cc} + 0.3$		
		P00 to P07, P10 to P17, P20 to P27, P30 to P37, P40 to P47, P50 to P57, P60 to P67, P70 to P77, P80 to P87, PS0 to PS4		$0.7 V_{cc}$	—	$V_{cc} + 0.3$		
			$V_{cc} = 2.5\text{ V to }5.5\text{ V}$	$0.8 V_{cc}$	—	$V_{cc} + 0.3$		
	Csync		$0.7 V_{cc}$	—	$V_{cc} + 0.3$			

Item	Symbol	Applicable Pins	Test Conditions	Values			Unit	Notes
				Min	Typ	Max		
Input low voltage	$V_{IL}$	MD0	$V_{CC} = 2.5\text{ V to }5.5\text{ V}$	-0.3	—	0.1 $V_{CC}$	V	
		RES, NMI, IC, IRQ0 to IRQ5		-0.3	—	0.2 $V_{CC}$		
			$V_{CC} = 2.5\text{ V to }5.5\text{ V}$	-0.3	—	0.1 $V_{CC}$		
		SCK1, SCK2, SI1, SI2, CS, FTIA, FTIB, FTIC, FTID, TRIG, TMBI, ADTRG		-0.3	—	0.2 $V_{CC}$		
		OSC1, X1		-0.3	—	0.5		
			$V_{CC} = 2.5\text{ V to }5.5\text{ V}$	-0.3	—	0.3		
		P00 to P07, P10 to P17, P20 to P27, P30 to P37, P40 to P47, P50 to P57, P60 to P67, P70 to P77, P80 to P87, PS0 to PS4		-0.3	—	0.3 $V_{CC}$		
			$V_{CC} = 2.5\text{ V to }5.5\text{ V}$	-0.3	—	0.2 $V_{CC}$		
	Csync			-0.3	—	0.2 $V_{CC}$		
Output high $V_{OH}$ voltage		SO1, SO2, SCK1, SCK2, PWM1, PWM2, PWM3, PWM4, PWM14, STRB, BUZZ, TMO, TMOW, FTOA, FTOB, PPG70 to PPG77, RP0 to RP7, P10 to P17, P20 to P27, P30 to P37, P40 to P47, P50 to P57, P60 to P67, P70 to P77, P80 to P87, PS0 to PS4	$-I_{OH} = 1.0\text{ mA}$	$V_{CC}$ -1.0	—	—	V	
			$-I_{OH} = 0.5\text{ mA}$	—	$V_{CC}$ -0.5	—	V	Reference value
			$-I_{OH} = 0.1\text{ mA}$	$V_{CC}$	—	—	V	
			$V_{CC} = 2.5\text{ V to }5.5\text{ V}$	-0.5				

Item	Symbol	Applicable Pins	Test Conditions	Values			Unit	Notes	
				Min	Typ	Max			
Output low voltage	$V_{OL}$	SO1, SO2, SCK1, SCK2, PWM1, PWM2, PWM3, PWM4, PWM14, STRB, BUZZ, TMO, TMOW, FTOA, FTOB, PPG70 to PPG77, RP0 to RP7, P10 to P17, P20 to P27, P30 to P37, P40 to P47, P50 to P57, P60 to P67, P70 to P77, PS0 to PS4	$I_{OL} = 1.6 \text{ mA}$	—	—	0.6	V		
			$I_{OL} = 0.4 \text{ mA}$ $V_{CC} = 2.5 \text{ V to } 5.5 \text{ V}$	—	—	0.4			
			P80 to P87	$I_{OL} = 20 \text{ mA}$	—	—			1.5
				$I_{OL} = 1.6 \text{ mA}$	—	—			0.6
				$I_{OL} = 0.4 \text{ mA}$ $V_{CC} = 2.5 \text{ V to } 5.5 \text{ V}$	—	—			0.4
Input/output leakage current	$ I_L $	MD0, OSC1, RES, NMI, IRQ0 to IRQ5, IC	$V_{in} = 0.5 \text{ to } V_{CC} - 0.5 \text{ V}$	—	—	1.0	$\mu\text{A}$		
			SCK1, SCK2, SI1, SI2, CS, FTIA, FTIB, FTIC, FTID, TRIG, TMBI, ADTRG	$V_{in} = 0.5 \text{ to } V_{CC} - 0.5 \text{ V}$	—	—			1.0
			P10 to P17, P20 to P27, P30 to P37, P40 to P47, P50 to P57, P60 to P67, P70 to P77, P80 to P87, PS0 to PS4	$V_{in} = 0.5 \text{ to } V_{CC} - 0.5 \text{ V}$	—	—			1.0
			P00 to P07, AN8 to ANB	$V_{in} = 0.5 \text{ to } AV_{CC} - 0.5 \text{ V}$	—	—			1.0



Item	Symbol	Applicable Pins	Test Conditions	Values			Unit	Notes
				Min	Typ	Max		
Pull-up MOS current	-I <sub>p</sub>	P10 to P17, P20 to P27, P30 to P37	V <sub>cc</sub> = 5.0 V, V <sub>in</sub> = 0 V	50	—	300	μA	Note 1
Input capacity	C <sub>in</sub>	All input pins except power supply, P23, P24 and analog system pins	f <sub>in</sub> = 1 MHz, V <sub>in</sub> = 0 V, T <sub>a</sub> = 25°C	—	—	15	pF	
		P23, P24	f <sub>in</sub> = 1 MHz, V <sub>in</sub> = 0 V, T <sub>a</sub> = 25°C	—	—	20		
Active mode current dissipation (CPU operating)	I <sub>OP</sub>	V <sub>cc</sub>	V <sub>cc</sub> = 5 V, f <sub>osc</sub> = 10-MHz High-speed mode	—	50	70	mA	Note 2  Reference value
			V <sub>cc</sub> = 5 V, f <sub>osc</sub> = 10-MHz Medium-speed mode (1/64)	—	35	—		
Active mode current dissipation (reset)	I <sub>RES</sub>	V <sub>cc</sub>	V <sub>cc</sub> = 5 V, f <sub>osc</sub> = 10 MHz	—	25	45	mA	Note 2
Sleep mode current dissipation	I <sub>SLEEP</sub>	V <sub>cc</sub>	V <sub>cc</sub> = 5 V, f <sub>osc</sub> = 10-MHz High-speed mode	—	20	30		
Subactive mode current dissipation	I <sub>SUB</sub>	V <sub>cc</sub>	V <sub>cc</sub> = 2.5 V, With 32-kHz crystal oscillator (φ <sub>sub</sub> = φ <sub>w</sub> /2)	—	40	100	μA	Note 2  Reference value, Note 2
			V <sub>cc</sub> = 2.5 V, With 32-kHz crystal oscillator (φ <sub>sub</sub> = φ <sub>w</sub> /8)	—	20	—		
Subsleep mode current dissipation	I <sub>SUBSLP</sub>	V <sub>cc</sub>	V <sub>cc</sub> = 2.5 V, With 32-kHz crystal oscillator (φ <sub>sub</sub> = φ <sub>w</sub> /2)	—	15	30	μA	Note 2  Reference value, Note 2
			V <sub>cc</sub> = 2.5 V, With 32-kHz crystal oscillator (φ <sub>sub</sub> = φ <sub>w</sub> /8)	—	10	—		

Item	Symbol	Applicable Pins	Test Conditions	Values			Unit	Notes
				Min	Typ	Max		
Watch mode current dissipation	$I_{WATCH}$	Vcc	Vcc = 2.5 V, With 32-kHz crystal oscillator	—	5	10	$\mu A$	Note 2
			Vcc = 5.0 V, With 32-kHz crystal oscillator	—	10	—		
Standby mode current dissipation	$I_{STBY}$	Vcc	X1 = Vcc, Without 32-kHz crystal oscillator	—	—	5		Note 2
RAM data retaining voltage in standby mode	$V_{STBY}$	Vcc		2.0	—	—	V	

Notes: Do not open the AVcc and AVss pin even when the A/D converter is not in use.

1. Current value when the relevant bit of the pull-up MOS select register (PUR1 to PUR3) is set to 1.
2. The current on the pull-up MOS or the output buffer excluded.

**Table 29.14 Pin Status at Current Dissipation Measurement**

Mode	RES Pin	Internal State	Pin	Oscillator Pin
Active mode High-speed, medium-speed	Vcc	Operating	Vcc	Main clock: Crystal oscillator Sub clock: X1 pin = Vcc
Sleep mode High-speed, medium-speed	Vcc	CPU and servo circuits stopped	Vcc	
Reset	Vss	Reset	Vcc	
Standby mode	Vcc	All stopped	Vcc	
Subactive mode	Vcc	CPU and timer A operating	Vcc	Main clock: Crystal oscillator Sub clock: Crystal oscillator
Subsleep mode	Vcc	Timer A operating	Vcc	
Watch mode	Vcc	Timer A operating	Vcc	

**Table 29.15 Bus Drive Characteristics of HD6432194, HD6432193, HD6432192, HD6432191, HD6432194C, HD6432194B, and HD6432194A**

(Conditions:  $V_{cc} = AV_{cc} = 4.0\text{ V to }5.5\text{ V}$ ,  $V_{ss} = 0.0\text{ V}$ ,  $T_a = -20\text{ to }+75^\circ\text{C}$  unless otherwise specified.) Applicable pin: SCL, SDA

Item	Symbol	Applicable Test		Values			Unit
		Pins	Conditions	Min	Typ	Max	
Schmidt trigger input voltage	$V_T^-$	SCL, SDA		0.2 $V_{cc}$	—	—	V
	$V_T^+$			—	—	0.7 $V_{cc}$	V
	$V_T^+$ $-V_T^-$			0.05 $V_{cc}$	—	—	V
Input High voltage	$V_{IH}$	SCL, SDA		0.7 $V_{cc}$	—	$V_{cc} + 0.5$	V
Input Low voltage	$V_{IL}$	SCL, SDA		-0.5	—	0.2 $V_{cc}$	V
Output Low voltage	$V_{OL}$	SCL, SDA	$I_{OL} = 8\text{ mA}$	—	—	0.5	V
			$I_{OL} = 3\text{ mA}$	—	—	0.4	
SCL and SDA output fall time	$t_{of}$	SCL, SDA		$20 + 0.1C_b$	—	250	ns

### 29.3.2 Allowable Output Currents of HD6432194, HD6432193, HD6432192, HD6432191, HD6432194C, HD6432194B, and HD6432194A

The specifications for the digital pins are shown below.

**Table 29.16 Allowable Output Currents of HD6432194, HD6432193, HD6432192, HD6432191, HD6432194C, HD6432194B, and HD6432194A**

(Conditions:  $V_{cc} = 2.5 \text{ V to } 5.5 \text{ V}$ ,  $V_{ss} = 0.0 \text{ V}$ ,  $T_a = -20 \text{ to } +75^\circ\text{C}$ )

Item	Symbol	Value	Unit	Notes
Allowable input current (to chip)	$I_o$	2	mA	1
Allowable input current (to chip)	$I_o$	22	mA	2
Allowable input current (to chip)	$I_o$	10	mA	3
Allowable output current (from chip)	$-I_o$	2	mA	4
Total allowable input current (to chip)	$\Sigma I_o$	80	mA	5
Total allowable output current (from chip)	$-\Sigma I_o$	50	mA	6

- Notes:
1. The allowable input current is the maximum value of the current flowing from each I/O pin to  $V_{ss}$  (except for port 8, SCL and SDA).
  2. The allowable input current is the maximum value of the current flowing from each I/O pin to  $V_{ss}$ . This applies to port 8.
  3. The allowable input current is the maximum value of the current flowing from each I/O pin to  $V_{ss}$ . This applies to SCL and SDA.
  4. The allowable output current is the maximum value of the current flowing from  $V_{cc}$  to each I/O pin.
  5. The total allowable input current is the sum of the currents flowing from all I/O pins to  $V_{ss}$  simultaneously.
  6. The total allowable output current is the sum of the currents flowing from  $V_{cc}$  to all I/O pins.

### 29.3.3 AC Characteristics of HD6432194, HD6432193, HD6432192, HD6432191, HD6432194C, HD6432194B, and HD6432194A

**Table 29.17 AC Characteristics of HD6432194, HD6432193, HD6432192, HD6432191, HD6432194C, HD6432194B, and HD6432194A**

(Conditions:  $V_{CC} = AV_{CC} = 4.0\text{ V to }5.5\text{ V}$ ,  $V_{SS} = AV_{SS} = 0.0\text{ V}$ ,  $T_a = -20\text{ to }+75^\circ\text{C}$  unless otherwise specified.)

Item	Symbol	Applicable Pins	Test Conditions	Values			Unit	Notes
				Min	Typ	Max		
Clock oscillation frequency	$f_{OSC}$	OSC1, OSC2		8	—	10	MHz	
Clock cycle time	$t_{cyc}$	OSC1, OSC2		100	—	125	ns	Figure 29.11
Subclock oscillation frequency	$f_x$	X1, X2	$V_{CC} = 2.5\text{ V to }5.5\text{ V}$	—	32.768	—	kHz	
Subclock cycle time	$t_{subcyc}$	X1, X2	$V_{CC} = 2.5\text{ V to }5.5\text{ V}$	—	30.518	—	$\mu\text{s}$	Figure 29.12
Oscillation stabilization time	$t_{rc}$	OSC1, OSC2	Crystal oscillator	—	—	10	ms	
		X1, X2	32-kHz crystal oscillator $V_{CC} = 2.5\text{ V to }5.5\text{ V}$	—	—	2	s	
External clock high width	$t_{CPH}$	OSC1		40	—	—	ns	Figure 29.11
External clock low width	$t_{CPL}$	OSC1		40	—	—	ns	
External clock rise time	$t_{CPr}$	OSC1		—	—	10	ns	
External clock fall time	$t_{CPr}$	OSC1		—	—	10	ns	
External clock stabilization delay time	$t_{DEXT}$	OSC1		500	—	—	$\mu\text{s}$	Figure 29.13

Item	Symbol	Applicable Pins	Test Conditions	Values			Unit	Notes
				Min	Typ	Max		
Subclock input low level pulse width	$t_{EXCLL}$	X1	$V_{CC} = 2.5\text{ V to } 5.5\text{ V}$	—	15.26	—	$\mu\text{s}$	Figure 29.12
Subclock input high level pulse width	$t_{EXCLH}$	X1	$V_{CC} = 2.5\text{ V to } 5.5\text{ V}$	—	15.26	—	$\mu\text{s}$	
Subclock input rise time	$t_{EXCLr}$	X1	$V_{CC} = 2.5\text{ V to } 5.5\text{ V}$	—	—	10	ns	Figure 29.12
Subclock input fall time	$t_{EXCLf}$	X1	$V_{CC} = 2.5\text{ V to } 5.5\text{ V}$	—	—	10	ns	
$\overline{\text{RES}}$ pin low level width	$t_{REL}$	$\overline{\text{RES}}$	$V_{CC} = 2.5\text{ V to } 5.5\text{ V}$	20	—	—	$t_{cyc}$	Figure 29.14
Input pin high level width	$t_{IH}$	$\overline{\text{IRQ0}}$ to $\overline{\text{IRQ5}}$ , $\overline{\text{NMI}}$ , $\overline{\text{IC}}$ , $\overline{\text{ADTRG}}$ , TMBI, FTIA, FTIB, FTIC, FTID, TRIG	$V_{CC} = 2.5\text{ V to } 5.5\text{ V}$	2	—	—	$t_{cyc}$ $t_{subcyc}$	Figure 29.15
Input pin low level width	$t_{IL}$	$\overline{\text{IRQ0}}$ to $\overline{\text{IRQ5}}$ , $\overline{\text{NMI}}$ , $\overline{\text{IC}}$ , $\overline{\text{ADTRG}}$ , TMBI, FTIA, FTIB, FTIC, FTID, TRIG	$V_{CC} = 2.5\text{ V to } 5.5\text{ V}$	2	—	—	$t_{cyc}$ $t_{subcyc}$	

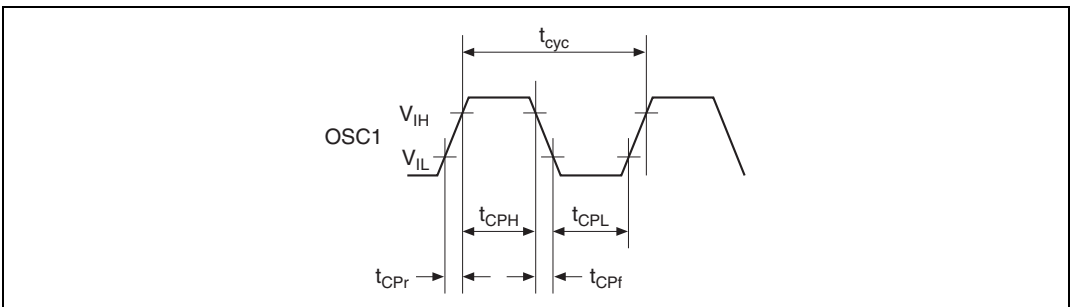
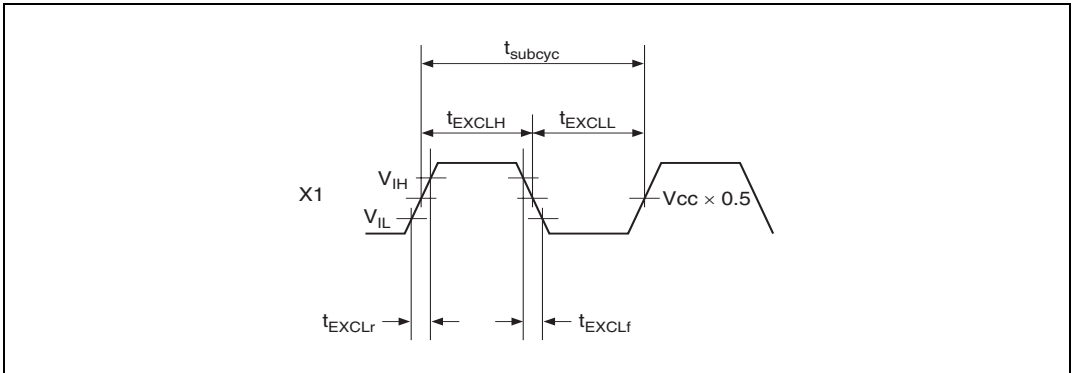
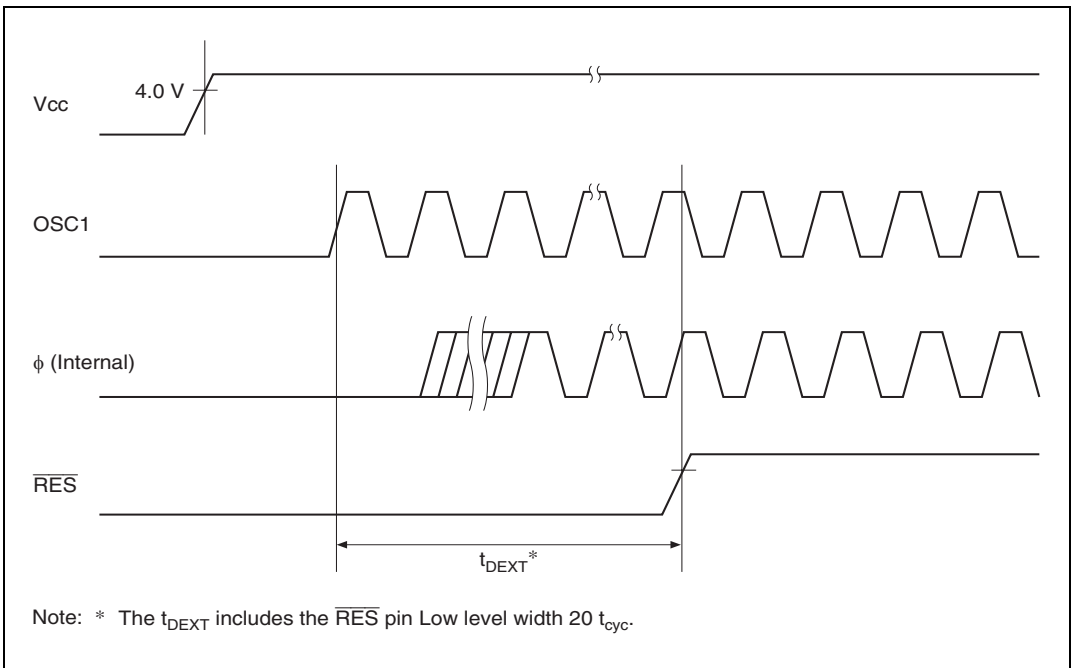


Figure 29.11 System Clock Timing



**Figure 29.12 Subclock Input Timing**



**Figure 29.13 External Clock Stabilization Delay Timing**

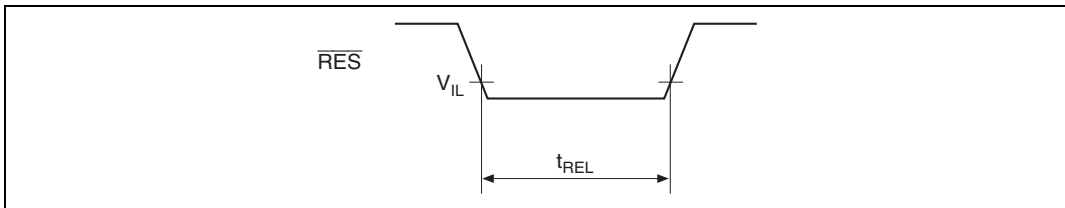


Figure 29.14 Reset Input Timing

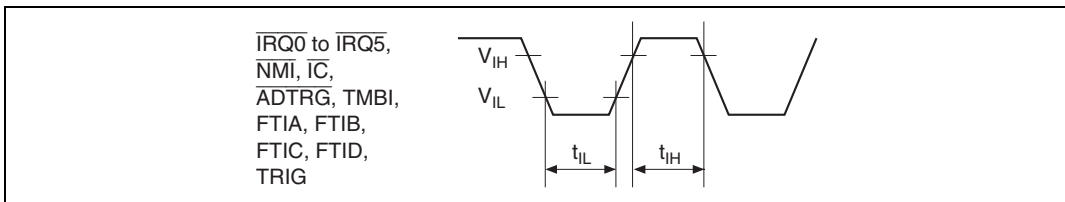


Figure 29.15 Input Timing

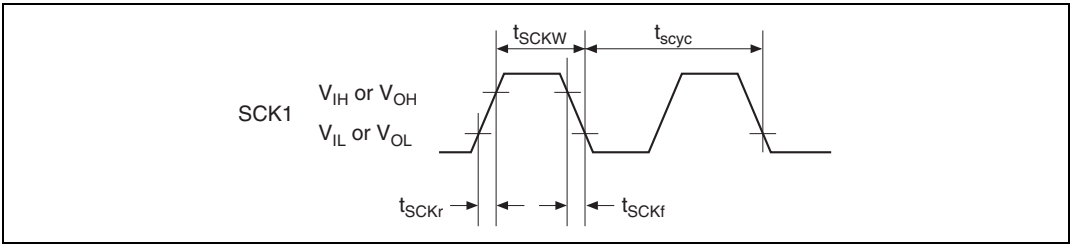


### 29.3.4 Serial Interface Timing of HD6432194, HD6432193, HD6432192, HD6432191, HD6432194C, HD6432194B, and HD6432194A

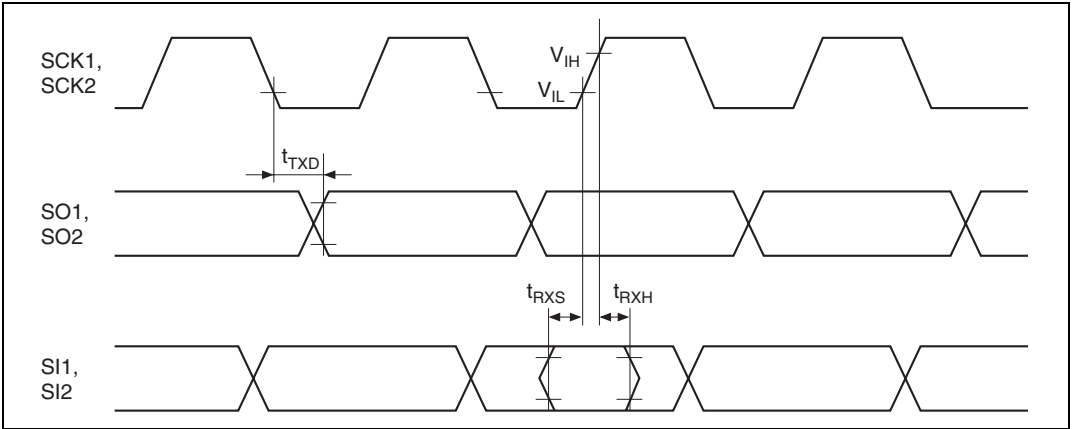
**Table 29.18 Serial Interface Timing of HD6432194, HD6432193, HD6432192, HD6432191, HD6432194C, HD6432194B, and HD6432194A**

(Conditions:  $V_{cc} = AV_{cc} = 4.0\text{ V}$  to  $5.5\text{ V}$ ,  $V_{ss} = AV_{ss} = 0.0\text{ V}$ ,  $T_a = -20$  to  $+75^\circ\text{C}$  unless otherwise specified.)

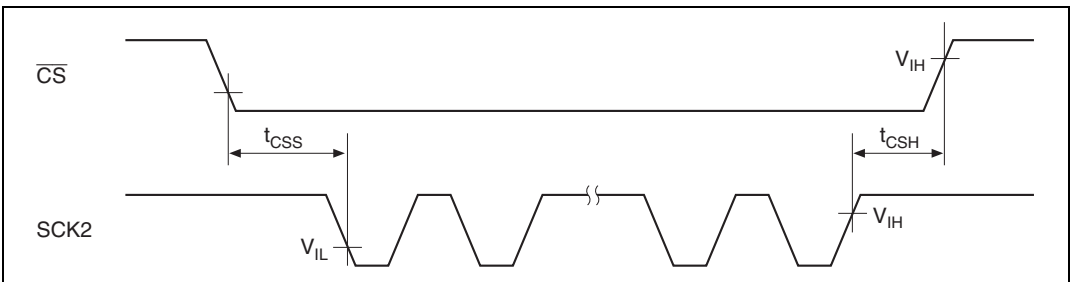
Item	Symbol	Applicable Test Pins	Test Conditions	Values			Unit	Figure
				Min	Typ	Max		
Input clock cycle	$t_{scyc}$	SCK1	Asynchronization	4	—	—	$t_{cyc}$	Figure 29.16
			Clock synchronization	6	—	—		
			SCK2	2	—	—		
Input clock pulse width	$t_{SCKW}$	SCK1, SCK2		0.4	—	0.6	$t_{scyc}$	
Input clock rise time	$t_{SCKr}$	SCK1		—	—	1.5	$t_{cyc}$	
		SCK2		—	—	60	ns	
Input clock fall time	$t_{SCKf}$	SCK1		—	—	1.5	$t_{cyc}$	
		SCK2		—	—	60	ns	
Transmit data delay time (clock sync)	$t_{TXD}$	SO1		—	—	100	ns	Figure 29.17
Receive data setup time (clock sync)	$t_{RXS}$	SI1		100	—	—	ns	
Receive data hold time (clock sync)	$t_{RXH}$	SI1		100	—	—	ns	
Transmit data output delay time	$t_{TXD}$	SO2		—	—	200	ns	Figure 29.17
Receive data setup time (clock sync)	$t_{RXS}$	SI2		180	—	—	ns	
Receive data hold time (clock sync)	$t_{RXH}$	SI2		180	—	—	ns	
$\overline{\text{CS}}$ setup time	$t_{CSS}$	$\overline{\text{CS}}$		1	—	—	$t_{scyc}$	Figure 29.18
$\overline{\text{CS}}$ hold time	$t_{CSH}$	$\overline{\text{CS}}$		1	—	—	$t_{scyc}$	



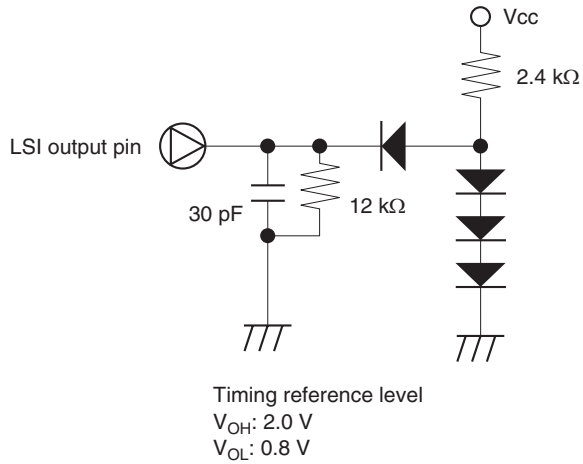
**Figure 29.16 SCK1 Clock Timing**



**Figure 29.17 SCI I/O Timing/Clock Synchronization Mode**



**Figure 29.18 SCI2 Chip Select Timing**

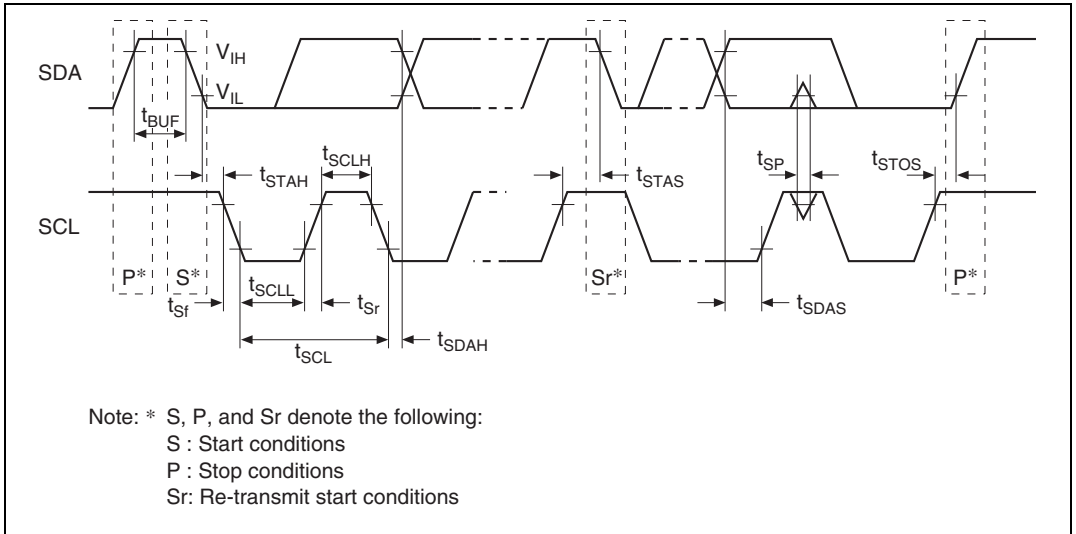
**Figure 29.19 Output Load Conditions**

**Table 29.19 I<sup>2</sup>C Bus Interface Timing of HD6432194, HD6432193, HD6432192, HD6432191, HD6432194C, HD6432194B, and HD6432194A**

(Conditions:  $V_{CC} = AV_{CC} = 4.0\text{ V to }5.5\text{ V}$ ,  $V_{SS} = AV_{SS} = 0.0\text{ V}$ ,  $T_a = -20\text{ to }+75^\circ\text{C}$  unless otherwise specified.)

Item	Symbol	Test Conditions	Values			Unit	Figure
			Min	Typ	Max		
SCL input cycle time	$t_{SCL}$		12	—	—	$t_{cyc}$	Figure 29.10
SCL input high pulse width	$t_{SCLH}$		3	—	—	$t_{cyc}$	
SCL input low pulse width	$t_{SCLL}$		5	—	—	$t_{cyc}$	
SCL, SDA input rise time	$t_{sr}$		—	—	7.5*	$t_{cyc}$	
SCL, SDA input fall time	$t_{sf}$		—	—	300	ns	
SCL, SDA input spike pulse removal time	$t_{sp}$		—	—	1	$t_{cyc}$	
SDA input bus free time	$t_{BUF}$		5	—	—	$t_{cyc}$	
Start condition input hold time	$t_{STAH}$		3	—	—	$t_{cyc}$	
Re-transmit start condition input setup time	$t_{STAS}$		3	—	—	$t_{cyc}$	
Stop condition input setup time	$t_{STOS}$		3	—	—	$t_{cyc}$	
Data input setup time	$t_{SDAS}$		0.5	—	—	$t_{cyc}$	
Data input hold time	$t_{SDAH}$		0	—	—	ns	
SCL, SDA capacity load	$C_b$		—	—	400	pF	

Note: \* Can also be set to  $17.5 t_{cyc}$  depending on the selection of clock to be used by the I<sup>2</sup>C module.



**Figure 29.20 I<sup>2</sup>C Bus Interface I/O Timing**

### 29.3.5 A/D Converter Characteristics of HD6432194, HD6432193, HD6432192, HD6432191, HD6432194C, HD6432194B, and HD6432194A

**Table 29.20 A/D Converter Characteristics of HD6432194, HD6432193, HD6432192, HD6432191, HD6432194C, HD6432194B, and HD6432194A**

(Conditions:  $V_{CC} = AV_{CC} = 4.0\text{ V to }5.5\text{ V}$ ,  $V_{SS} = AV_{SS} = 0.0\text{ V}$ ,  $T_a = -20\text{ to }+75^\circ\text{C}$  unless otherwise specified.)

Item	Symbol	Applicable Pins	Test Conditions	Values			Unit
				Min	Typ	Max	
Analog power supply voltage	$AV_{CC}$	$AV_{CC}$		$V_{CC}$ -0.3	$V_{CC}$	$V_{CC} + 0.3$	V
Analog input voltage	$A_{VIN}$	AN0 to AN7, AN8 to ANB		$AV_{SS}$	—	$AV_{CC}$	V
Analog power supply current	$A_{ICC}$	$AV_{CC}$	$AV_{CC} = 5.0\text{ V}$	—	—	2.0	mA
	$A_{ISTOP}$	$AV_{CC}$	$V_{CC} = 2.5\text{ V to }5.5\text{ V}$ , at reset and in power-down mode	—	—	10	$\mu\text{A}$
Analog input capacitance	$C_{AIN}$	AN0 to AN7, AN8 to ANB		—	—	30	pF
Allowable signal source impedance	$R_{AIN}$	AN0 to AN7, AN8 to ANB		—	—	10	k $\Omega$
Resolution				—	—	10	Bit
Absolute accuracy			$AV_{CC} = 5.0\text{ V}$	—	—	$\pm 4$	LSB
Conversion time				13.4	—	26.6	$\mu\text{s}$

Note: Do not open the  $AV_{CC}$  and  $AV_{SS}$  pin even when the A/D converter is not in use. Set  $AV_{CC} = V_{CC}$  and  $AV_{SS} = V_{SS}$ .

### 29.3.6 Servo Section Electrical Characteristics of HD6432194, HD6432193, HD6432192, HD6432191, HD6432194C, HD6432194B, and HD6432194A

**Table 29.21 Servo Section Electrical Characteristics of HD6432194, HD6432193, HD6432192, HD6432191, HD6432194C, HD6432194B, and HD6432194A (reference values)**

(Conditions:  $V_{CC} = SV_{CC} = 5.0\text{ V}$ ,  $V_{SS} = SV_{SS} = 0.0\text{ V}$ ,  $T_a = 25^\circ\text{C}$  unless otherwise specified.)

Item	Applicable Symbol Pins	Test Conditions	Reference Values			Unit
			Min	Typ	Max	
PB-CTL input amplifier voltage gain	CTL (+)	CTLGR3 = 0, CTLGR2 = 0, CTLGR1 = 0, CTLGR0 = 0, f = 10 kHz	32.0	34.0	36.0	dB
		CTLGR3 = 0, CTLGR2 = 0, CTLGR1 = 0, CTLGR0 = 1, f = 10 kHz	34.5	36.5	38.5	
		CTLGR3 = 0, CTLGR2 = 0, CTLGR1 = 1, CTLGR0 = 0, f = 10 kHz	37.0	39.0	41.0	
		CTLGR3 = 0, CTLGR2 = 0, CTLGR1 = 1, CTLGR0 = 1, f = 10 kHz	39.5	41.5	43.5	
		CTLGR3 = 0, CTLGR2 = 1, CTLGR1 = 0, CTLGR0 = 0, f = 10 kHz	42.0	44.0	46.0	
		CTLGR3 = 0, CTLGR2 = 1, CTLGR1 = 0, CTLGR0 = 1, f = 10 kHz	44.5	46.5	48.5	
		CTLGR3 = 0, CTLGR2 = 1, CTLGR1 = 1, CTLGR0 = 0, f = 10 kHz	47.0	49.0	51.0	
		CTLGR3 = 0, CTLGR2 = 1, CTLGR1 = 1, CTLGR0 = 1, f = 10 kHz	49.5	51.5	53.5	
		CTLGR3 = 1, CTLGR2 = 0, CTLGR1 = 0, CTLGR0 = 0, f = 10 kHz	52.0	54.0	56.0	
		CTLGR3 = 1, CTLGR2 = 0, CTLGR1 = 0, CTLGR0 = 1, f = 10 kHz	54.5	56.5	58.5	
		CTLGR3 = 1, CTLGR2 = 0, CTLGR1 = 1, CTLGR0 = 0, f = 10 kHz	57.0	59.0	61.0	
		CTLGR3 = 1, CTLGR2 = 0, CTLGR1 = 1, CTLGR0 = 1, f = 10 kHz	59.5	61.5	63.5	
		CTLGR3 = 1, CTLGR2 = 1, CTLGR1 = 0, CTLGR0 = 0, f = 10 kHz	62.0	64.0	66.0	
CTLGR3 = 1, CTLGR2 = 1, CTLGR1 = 0, CTLGR0 = 1, f = 10 kHz	64.5	66.5	68.5			
CTLGR3 = 1, CTLGR2 = 1, CTLGR1 = 1, CTLGR0 = 0, f = 10 kHz	67.0	69.0	71.0			
CTLGR3 = 1, CTLGR2 = 1, CTLGR1 = 1, CTLGR0 = 1, f = 10 kHz	69.5	71.5	73.5			

Item	Symbol	Applicable Pins	Test Conditions	Reference Values			Unit
				Min	Typ	Max	
PB-CTL Schmidt input	V+TH	CTLSMT (i)	AC coupling, C = 0.1 $\mu$ F Typ (non pol)	—	250	—	mVp
	V-TH			—	-250	—	
Analog switch ON resistance	REB			—	150	—	$\Omega$
REC-CTL output current	ICTL	CTL (+)	Series resistance = 0 $\Omega$	—	8	—	mA
		CTL (-)		—	8	—	
REC-CTL inter-pin resistance	RCTL			—	10	—	k $\Omega$
CTL reference output voltage		CTLREF		—	1/2 SV <sub>cc</sub>	—	V
CFG pin bias voltage		CFG		—	1/2 SV <sub>cc</sub>	—	V
CFG input level		CFG	AC coupling, C = 1 $\mu$ F Typ, f = 1 kHz	1.0	—	—	V <sub>pp</sub>
CFG input impedance		CFG		—	10	—	k $\Omega$
CFG input threshold value	V+THCF	CFG	Rise threshold level	—	2.25	—	V
	V-THCF		Fall threshold level	—	2.75	—	
DFG Schmidt input	V+THDF	DFG	Rising edge Schmidt level	—	1.95	—	V
	V-THDF		Falling edge Schmidt level	—	1.85	—	
DPG Schmidt input	V+THDP	DPG	Rising edge Schmidt level	—	3.55	—	V
	V-THDP		Falling edge Schmidt level	—	3.45	—	
3-level output voltage	V <sub>OH</sub>	Vpulse	-I <sub>OH</sub> = 0.1 mA	4.0	—	—	V
	V <sub>OM</sub>		No load, Hi-Z = 1	—	2.5	—	
	V <sub>OL</sub>		I <sub>OL</sub> = 0.1 mA	—	—	1.0	
3-level output pin divided voltage resistance		Vpulse		—	15	—	k $\Omega$
CFG Duty		CFG	AC coupling, C = 1 $\mu$ F Typ, f = 1 kHz	48	—	52	%



**Table 29.22 Servo Section Electrical Characteristics of HD6432194, HD6432193, HD6432192, HD6432191, HD6432194C, HD6432194B, and HD6432194A**

(Conditions:  $V_{cc} = SV_{cc} = 5.0\text{ V}$ ,  $V_{ss} = SV_{ss} = 0.0\text{ V}$ ,  $T_a = 25^\circ\text{C}$  unless otherwise specified.)

Item	Symbol	Applicable Pins	Test Conditions	Values			Unit
				Min	Typ	Max	
Digital input high voltage	$V_{IH}$	COMP, EXCTL, EXCAP, EXTTRG		0.8 $V_{cc}$	—	$V_{cc} + 0.3$	V
Digital input low voltage	$V_{IL}$			-0.3	—	0.2 $V_{cc}$	
Digital output high voltage	$V_{OH}$	H.AmpSW, C.Rotary,	$-I_{OH} = 1\text{ mA}$	$V_{cc}$ -1.0	—	—	V
Digital output low voltage	$V_{OL}$	VIDEOFF, AUDIOFF, DRMPWM, CAPPWM, SV1, SV2	$I_{OL} = 1.6\text{ mA}$	—	—	0.6	
Current dissipation	$I_{CCSV}$	SVcc	At no load	—	5	10	mA



# Appendix A Instruction Set

## A.1 Instructions

### Operation Notation

Rd	General register (destination) <sup>*1</sup>
Rs	General register (source) <sup>*1</sup>
Rn	General register <sup>*1</sup>
ERn	General register (32-bit register)
MAC	Multiplication-Addition register (32-bit register) <sup>*2</sup>
(EAd)	Destination operand
(EAs)	Source operand
EXR	Extend register
CCR	Condition code register
N	N (negative flag) in CCR
Z	Z (zero) flag in CCR
V	V (overflow) flag in CCR
C	C (carry) flag in CCR
PC	Program counter
SP	Stack pointer
#IMM	Immediate data
disp	Displacement
+	Addition
–	Subtraction
×	Multiplication
÷	Division
^	Logical AND
∨	Logical OR
⊕	Exclusive logical OR
→	Move from the left to the right
~	Logical complement
( ) <>	Contents of operand
:8/:16/:24/:32	8-, 16-, 24-, 32-bit length

- Notes: 1. General register is 8-bit (R0H to R7H, R0L to R7L), 16-bit (R0 to R7) or 32-bit (ER0 to ER7).
2. MAC register cannot be used in this LSI.

### Condition Code Notation

Symbol	Description
↓	Modified according to the instruction result
*	Not fixed (value not guaranteed)
0	Always cleared to 0
1	Always set to 1
—	Not affected by the instruction execution result

Table A.1 List of Instruction Set

## (1) Data Transfer Instruction

Mnemonic		Size	Addressing Mode and Instruction Length (Bytes)								Operation	Condition Code					No of Execution States *1			
			#xx	Rn	@ERn	@ (d)ERn	@-ERn/@ERn+	@aa	@ (d)PC	@ @aa			I	H	N	Z		V	C	Advanced Mode
MOV	MOV.B #xx:8,Rd	B	2								#xx:8→Rd8	—	—	↑	↑	0	—	1		
	MOV.B Rs,Rd	B		2							Rs8→Rd8	—	—	↑	↑	0	—	1		
	MOV.B @ERs,Rd	B			2						@ERs→Rd8	—	—	↑	↑	0	—	2		
	MOV.B @(d:16,ERs),Rd	B				4					@(d:16,ERs)→Rd8	—	—	↑	↑	0	—	3		
	MOV.B @(d:32,ERs),Rd	B				8					@(d:32,ERs)→Rd8	—	—	↑	↑	0	—	5		
	MOV.B @ERs+,Rd	B					2				@ERs→Rd8,ERs32+1→ERs32	—	—	↑	↑	0	—	3		
	MOV.B @aa:8,Rd	B						2			@aa:8→Rd8	—	—	↑	↑	0	—	2		
	MOV.B @aa:16,Rd	B						4			@aa:16→Rd8	—	—	↑	↑	0	—	3		
	MOV.B @aa:32,Rd	B						6			@aa:32→Rd8	—	—	↑	↑	0	—	4		
	MOV.B Rs,@ERd	B			2						Rs8→@ERd	—	—	↑	↑	0	—	2		
	MOV.B Rs,@(d:16,ERd)	B				4					Rs8→@(d:16,ERd)	—	—	↑	↑	0	—	3		
	MOV.B Rs,@(d:32,ERd)	B				8					Rs8→@(d:32,ERd)	—	—	↑	↑	0	—	5		
	MOV.B Rs,@-ERd	B					2				ERd32-1→ERd32,Rs8→@ERd	—	—	↑	↑	0	—	3		
	MOV.B Rs,@aa:8	B						2			Rs8→@aa:8	—	—	↑	↑	0	—	2		
	MOV.B Rs,@aa:16	B						4			Rs8→@aa:16	—	—	↑	↑	0	—	3		
	MOV.B Rs,@aa:32	B						6			Rs8→@aa:32	—	—	↑	↑	0	—	4		
	MOV.W #xx:16,Rd	W	4								#xx:16→Rd16	—	—	↑	↑	0	—	2		
	MOV.W Rs,Rd	W		2							Rs16→Rd16	—	—	↑	↑	0	—	1		
	MOV.W @ERs,Rd	W			2						@ERs→Rd16	—	—	↑	↑	0	—	2		
	MOV.W @(d:16,ERs),Rd	W				4					@(d:16,ERs)→Rd16	—	—	↑	↑	0	—	3		
	MOV.W @(d:32,ERs),Rd	W				8					@(d:32,ERs)→Rd16	—	—	↑	↑	0	—	5		
	MOV.W @ERs+,Rd	W					2				@ERs→Rd16,ERs32+2→ERs32	—	—	↑	↑	0	—	3		
	MOV.W @aa:16,Rd	W						4			@aa:16→Rd16	—	—	↑	↑	0	—	3		
	MOV.W @aa:32,Rd	W						6			@aa:32→Rd16	—	—	↑	↑	0	—	4		
	MOV.W Rs,@ERd	W			2						Rs16→@ERd	—	—	↑	↑	0	—	2		
	MOV.W Rs,@(d:16,ERd)	W				4					Rs16→@(d:16,ERd)	—	—	↑	↑	0	—	3		
	MOV.W Rs,@(d:32,ERd)	W				8					Rs16→@(d:32,ERd)	—	—	↑	↑	0	—	5		
	MOV.W Rs,@-ERd	W					2				ERd32-2→ERd32,Rs16→@ERd	—	—	↑	↑	0	—	3		
	MOV.W Rs,@aa:16	W						4			Rs16→@aa:16	—	—	↑	↑	0	—	3		
	MOV.W Rs,@aa:32	W						6			Rs16→@aa:32	—	—	↑	↑	0	—	4		
	MOV.L #xx:32,ERd	L	6								#xx:32→ERd32	—	—	↑	↑	0	—	3		
	MOV.L ERs,ERd	L		2							ERs32→ERd32	—	—	↑	↑	0	—	1		
MOV.L @ERs,ERd	L			4						@ERs→ERd32	—	—	↑	↑	0	—	4			
MOV.L @(d:16,ERs),ERd	L				6					@(d:16,ERs)→ERd32	—	—	↑	↑	0	—	5			
MOV.L @(d:32,ERs),ERd	L				10					@(d:32,ERs)→ERd32	—	—	↑	↑	0	—	7			
MOV.L @ERs+,ERd	L					4				@ERs→ERd32,ERs32+4→ERs32	—	—	↑	↑	0	—	5			
MOV.L @aa:16,ERd	L						6			@aa:16→ERd32	—	—	↑	↑	0	—	5			
MOV.L @aa:32,ERd	L						8			@aa:32→ERd32	—	—	↑	↑	0	—	6			
MOV.L ERs,@ERd	L			4						ERs32→@ERd	—	—	↑	↑	0	—	4			
MOV.L ERs,@(d:16,ERd)	L				6					ERs32→@(d:16,ERd)	—	—	↑	↑	0	—	5			
MOV.L ERs,@(d:32,ERd)	L				10					ERs32→@(d:32,ERd)	—	—	↑	↑	0	—	7			
MOV.L ERs,@-ERd	L					4				ERd32-4→ERd32,ERs32→@ERd	—	—	↑	↑	0	—	5			
MOV.L ERs,@aa:16	L						6			ERs32→@aa:16	—	—	↑	↑	0	—	5			
MOV.L ERs,@aa:32	L						8			ERs32→@aa:32	—	—	↑	↑	0	—	6			
POP	POP.W Rn	W						2		@SP→Rn16,SP+2→SP	—	—	↑	↑	0	—	3			
	POP.L ERn	L						4		@SP→ERn32,SP+4→SP	—	—	↑	↑	0	—	5			
PUSH	PUSH.W Rn	W						2		SP-2→SP,Rn16→@SP	—	—	↑	↑	0	—	3			
	PUSH.L ERn	L						4		SP-4→SP,ERn32→@SP	—	—	↑	↑	0	—	5			
LDM	LDM @SP+,(ERm-ERn)	L						4		(@SP→ERn32,SP+4→SP) Repeat for the number of returns	—	—	—	—	—	—	7/9/11 [1]			
STM	STM (ERm-ERn),@-SP	L						4		(SP-4→SP,ERn32→@SP) Repeat for the number of returns	—	—	—	—	—	—	7/9/11 [1]			
MOVFPE	MOVFPE @aa:16,Rd																[2]			
MOVTPPE	MOVTPPE Rs,@aa:16																[2]			

Cannot be used in this LSI

## (2) Arithmetic Instructions

Mnemonic	Size	Addressing Mode and Instruction Length (Bytes)										Operation	Condition Code					No of Execution States *1						
		#xx	Rn	@ERn	@ (U,ERn)	@-ERn/@ERn+	@aa	@ (LPC)	@ @aa		I		H	N	Z	V	C		Advanced Mode					
ADD	ADD.B #xx:8,Rd	B	2														Rd8+#xx:8→Rd8	—	↑	↑	↑	↑	↑	1
	ADD.B Rs,Rd	B	2														Rd8+Rs8→Rd8	—	↑	↑	↑	↑	↑	1
	ADD.W #xx:16,Rd	W	4														Rd16+#xx:16→Rd16	—	[3]	↑	↑	↑	↑	2
	ADD.W Rs,Rd	W	2														Rd16+Rs16→Rd16	—	[3]	↑	↑	↑	↑	1
	ADD.L #xx:32,ERd	L	6														ERd32+#xx:32→ERd32	—	[4]	↑	↑	↑	↑	3
ADD.L ERs,ERd	L	2														ERd32+ERs32→ERd32	—	[4]	↑	↑	↑	↑	1	
ADDX	ADDX #xx:8,Rd	B	2														Rd8+#xx:8+C→Rd8	—	↑	↑	[5]	↑	↑	1
	ADDX Rs,Rd	B	2														Rd8+Rs8+C→Rd8	—	↑	↑	[5]	↑	↑	1
ADDS	ADDS #1,ERd	L	2														ERd32+1→ERd32	—	↑	↑	↑	↑	↑	1
	ADDS #2,ERd	L	2														ERd32+2→ERd32	—	↑	↑	↑	↑	↑	1
	ADDS #4,ERd	L	2														ERd32+4→ERd32	—	↑	↑	↑	↑	↑	1
INC	INC.B Rd	B	2														Rd8+1→Rd8	—	↑	↑	↑	↑	↑	1
	INC.W #1,Rd	W	2														Rd16+1→Rd16	—	↑	↑	↑	↑	↑	1
	INC.W #2,Rd	W	2														Rd16+2→Rd16	—	↑	↑	↑	↑	↑	1
	INC.L #1,ERd	L	2														ERd32+1→ERd32	—	↑	↑	↑	↑	↑	1
INC.L #2,ERd	L	2														ERd32+2→ERd32	—	↑	↑	↑	↑	↑	1	
DAA	DAA Rd	B	2														Rd8 10 Decimal adjust →Rd8	—	*	↑	↑	*	↑	1
SUB	SUB.B Rs,Rd	B	2														Rd8-Rs8→Rd8	—	↑	↑	↑	↑	↑	1
	SUB.W #xx:16,Rd	W	4														Rd16-#xx:16→Rd16	—	[3]	↑	↑	↑	↑	2
	SUB.W Rs,Rd	W	2														Rd16-Rs16→Rd16	—	[3]	↑	↑	↑	↑	1
	SUB.L #xx:32,ERd	L	6														ERd32-#xx:32→ERd32	—	[4]	↑	↑	↑	↑	3
	SUB.L ERs,ERd	L	2														ERd32-ERs32→ERd32	—	[4]	↑	↑	↑	↑	1
SUBX	SUBX #xx:8,Rd	B	2														Rd8-#xx:8-C→Rd8	—	↑	↑	[5]	↑	↑	1
	SUBX Rs,Rd	B	2														Rd8-Rs8-C→Rd8	—	↑	↑	[5]	↑	↑	1
SUBS	SUBS #1,ERd	L	2														ERd32-1→ERd32	—	↑	↑	↑	↑	↑	1
	SUBS #2,ERd	L	2														ERd32-2→ERd32	—	↑	↑	↑	↑	↑	1
	SUBS #4,ERd	L	2														ERd32-4→ERd32	—	↑	↑	↑	↑	↑	1
DEC	DEC.B Rd	B	2														Rd8-1→Rd8	—	↑	↑	↑	↑	↑	1
	DEC.W #1,Rd	W	2														Rd16-1→Rd16	—	↑	↑	↑	↑	↑	1
	DEC.W #2,Rd	W	2														Rd16-2→Rd16	—	↑	↑	↑	↑	↑	1
	DEC.L #1,ERd	L	2														ERd32-1→ERd32	—	↑	↑	↑	↑	↑	1
DEC.L #2,ERd	L	2														ERd32-2→ERd32	—	↑	↑	↑	↑	↑	1	
DAS	DAS Rd	B	2														Rd8 10 Decimal adjust →Rd8	—	*	↑	↑	*	↑	1
MULXU	MULXU.B Rs,Rd	B	2														Rd8-Rs8→Rd16(Multiplication w/o sign)	—	↑	↑	↑	↑	↑	12
	MULXU.W Rs,ERd	W	2														Rd16-Rs16→ERd32(Multiplication w/o sign)	—	↑	↑	↑	↑	↑	20
MULXS	MULXS.B Rs,Rd	B	4														Rd8-Rs8→Rd16(Multiplication w/o sign)	—	↑	↑	↑	↑	↑	13
	MULXS.W Rs,ERd	W	4														Rd16-Rs16→ERd32(Multiplication w/o sign)	—	↑	↑	↑	↑	↑	21
DIVXU	DIVXU.B Rs,Rd	B	2														Rd16-Rs8→Rd16 (RdH: Rmainder, RdL: Quotient)(Division w/o sign)	—	↑	[6]	[7]	↑	↑	12
	DIVXU.W Rs,ERd	W	2														ERd32-Rs16→ERd32 (Ed:Remainder, Rd: Quotient)(Division with sign)	—	↑	[6]	[7]	↑	↑	20
DIVXS	DIVXS.B Rs,Rd	B	4														Rd16-Rs8→Rd16(RdH: Rmainder, RdL: Quotient)(Division w/o sign)	—	↑	[8]	[7]	↑	↑	13
	DIVXS.W Rs,ERd	W	4														ERd32-Rs16→ERd32 (Ed:Remainder, Rd: Quotient)(Division with sign)	—	↑	[8]	[7]	↑	↑	21
CMP	CMP.B #xx:8,Rd	B	2														Rd8-#xx:8	—	↑	↑	↑	↑	↑	1
	CMP.B Rs,Rd	B	2														Rd8-Rs8	—	↑	↑	↑	↑	↑	1
	CMP.W #xx:16,Rd	W	4														Rd16-#xx:16	—	[3]	↑	↑	↑	↑	2
	CMP.W Rs,Rd	W	2														Rd16-Rs16	—	[3]	↑	↑	↑	↑	1
	CMP.L #xx:32,ERd	L	6														ERd32-#xx:32	—	[4]	↑	↑	↑	↑	3
CMP.L ERs,ERd	L	2														ERd32-ERs32	—	[4]	↑	↑	↑	↑	1	
NEG	NEG.B Rd	B	2														0-Rd8→Rd8	—	↑	↑	↑	↑	↑	1
	NEG.W Rd	W	2														0-Rd16→Rd16	—	↑	↑	↑	↑	↑	1
	NEG.L ERd	L	2														0-ERd32→ERd32	—	↑	↑	↑	↑	↑	1
EXTU	EXTU.W Rd	W	2														0-→(<Bits 15 to 8> of Rd16)	—	0	↑	0	↑	↑	1
EXTS	EXTS.L ERd	L	2														0-→(<Bits 31 to 16> of ERd32)	—	0	↑	0	↑	↑	1
EXTS	EXTS.W Rd	W	2														<Bbit7> of Rd16)→ <Bits 15 to 8> of Rd16)	—	↑	↑	↑	↑	↑	1
	EXTS.L ERd	L	2														<Bbit15> of ERd32)→ <Bits31 to 16> of ERd32)	—	↑	↑	↑	↑	↑	1
TAS*2	TAS @ERd	B				4											@ERd-0-CCR set, (1)→ <Bbit7> of @ERd)	—	↑	↑	↑	0	↑	4
MAC	MAC @ERn+,@ERm+																							
CLRMAC	CLRMAC																							
LDMAC	LDMAC ERs,MACH																							
	LDMAC ERs,MACL																							
STMAC	STMAC MACH,ERd																							
	STMAC MACL,ERd																							

Cannot be used in this LSI

[2]

## (3) Logic Operations Instructions

Mnemonic	Size	Addressing Mode and Instruction Length (Bytes)									Operation	Condition Code					No of Execution States *1		
		#xx	Rn	@ERn	@ (d,ERn)	@-ERn/@ERn+	@aa	@ (d,PC)	@@aa			I	H	N	Z	V		C	Advanced Mode
AND	AND.B #xx:8,Rd	B	2															1	
	AND.B Rs,Rd	B		2														1	
	AND.W #xx:16,Rd	W	4															2	
	AND.W Rs,Rd	W		2														1	
	AND.L #xx:32,ERd	L	6															3	
	AND.L ERs,ERd	L		4														2	
OR	OR.B #xx:8,Rd	B	2															1	
	OR.B Rs,Rd	B		2														1	
	OR.W #xx:16,Rd	W	4															2	
	OR.W Rs,Rd	W		2														1	
	OR.L #xx:32,ERd	L	6															3	
	OR.L ERs,ERd	L		4														2	
XOR	XOR.B #xx:8,Rd	B	2															1	
	XOR.B Rs,Rd	B		2														1	
	XOR.W #xx:16,Rd	W	4															2	
	XOR.W Rs,Rd	W		2														1	
	XOR.L #xx:32,ERd	L	6															3	
	XOR.L ERs,ERd	L		4														2	
NOT	NOT.B Rd	B		2														1	
	NOT.W Rd	W		2														1	
	NOT.L ERd	L		2														1	

(4) Shift Instructions

Mnemonic	Size	Addressing Mode and Instruction Length (Bytes)								Operation	Condition Code					No of Execution States *1		
		#xx	Rn	@ERn	@(d,ERn)	@-ERn/@ERn+	@aa	@(d,PC)	@@aa		I	H	N	Z	V		C	
		Advanced Mode																
SHAL	SHAL.B Rd	B	2															1
	SHAL.B #2,Rd	B	2															1
	SHAL.W Rd	W	2															1
	SHAL.W #2,Rd	W	2															1
	SHALL ERd	L	2															1
SHAR	SHAR.B Rd	B	2															1
	SHAR.B #2,Rd	B	2															1
	SHAR.W Rd	W	2															1
	SHAR.W #2,Rd	W	2															1
	SHAR.L ERd	L	2															1
SHLL	SHLL.B Rd	B	2															1
	SHLL.B #2,Rd	B	2															1
	SHLL.W Rd	W	2															1
	SHLL.W #2,Rd	W	2															1
	SHLL.L ERd	L	2															1
SHLR	SHLR.B Rd	B	2															1
	SHLR.B #2,Rd	B	2															1
	SHLR.W Rd	W	2															1
	SHLR.W #2,Rd	W	2															1
	SHLR.L ERd	L	2															1
ROTXL	ROTXL.B Rd	B	2															1
	ROTXL.B #2,Rd	B	2															1
	ROTXL.W Rd	W	2															1
	ROTXL.W #2,Rd	W	2															1
	ROTXL.L ERd	L	2															1
ROTXR	ROTXR.B Rd	B	2															1
	ROTXR.B #2,Rd	B	2															1
	ROTXR.W Rd	W	2															1
	ROTXR.W #2,Rd	W	2															1
	ROTXR.L ERd	L	2															1
ROTL	ROTL.B Rd	B	2															1
	ROTL.B #2,Rd	B	2															1
	ROTL.W Rd	W	2															1
	ROTL.W #2,Rd	W	2															1
	ROTL.L ERd	L	2															1
ROTR	ROTR.B Rd	B	2															1
	ROTR.B #2,Rd	B	2															1
	ROTR.W Rd	W	2															1
	ROTR.W #2,Rd	W	2															1
	ROTR.L ERd	L	2															1



## (5) Bit Manipulation Instructions

Mnemonic	Size	Addressing Mode and Instruction Length (Bytes)								Operation	Condition Code					No of Execution States *1
		#xx	Rn	@ERn	@(d,ERn)	@-ERn/@ERn+	@aa	@(d,PC)	@aa		I	H	N	Z	V	
			n	4			4									
BSET	BSET #xx:3,Rd	B								(#xx:3 of Rd8)←1						1
	BSET #xx:3,@ERd	B		4						(#xx:3 of @ERd)←1						4
	BSET #xx:3,@aa:8	B					4			(#xx:3 of @aa:8)←1						4
	BSET #xx:3,@aa:16	B					6			(#xx:3 of @aa:16)←1						5
	BSET #xx:3,@aa:32	B					8			(#xx:3 of @aa:32)←1						6
	BSET Rn,Rd	B	2							(Rn8 of Rd8)←1						1
	BSET Rn,@ERd	B		4						(Rn8 of @ERd)←1						4
	BSET Rn,@aa:8	B					4			(Rn8 of @aa:8)←1						4
	BSET Rn,@aa:16	B					6			(Rn8 of @aa:16)←1						5
BSET Rn,@aa:32	B					8			(Rn8 of @aa:32)←1						6	
BCLR	BCLR #xx:3,Rd	B	2							(#xx:3 of Rd8)←0						1
	BCLR #xx:3,@ERd	B		4						(#xx:3 of @ERd)←0						4
	BCLR #xx:3,@aa:8	B					4			(#xx:3 of @aa:8)←0						4
	BCLR #xx:3,@aa:16	B					6			(#xx:3 of @aa:16)←0						5
	BCLR #xx:3,@aa:32	B					8			(#xx:3 of @aa:32)←0						6
	BCLR Rn,Rd	B	2							(Rn8 of Rd8)←0						1
	BCLR Rn,@ERd	B		4						(Rn8 of @ERd)←0						4
	BCLR Rn,@aa:8	B					4			(Rn8 of @aa:8)←0						4
	BCLR Rn,@aa:16	B					6			(Rn8 of @aa:16)←0						5
BCLR Rn,@aa:32	B					8			(Rn8 of @aa:32)←0						6	
BNOT	BNOT #xx:3,Rd	B	2							(#xx:3 of Rd8)←!(#xx:3 of Rd8)						1
	BNOT #xx:3,@ERd	B		4						(#xx:3 of @ERd)←!(#xx:3 of @ERd)						4
	BNOT #xx:3,@aa:8	B					4			(#xx:3 of @aa:8)←!(#xx:3 of @aa:8)						4
	BNOT #xx:3,@aa:16	B					6			(#xx:3 of @aa:16)←!(#xx:3 of @aa:16)						5
	BNOT #xx:3,@aa:32	B					8			(#xx:3 of @aa:32)←!(#xx:3 of @aa:32)						6
	BNOT Rn,Rd	B	2							(Rn8 of Rd8)←!(Rn8 of Rd8)						1
	BNOT Rn,@ERd	B		4						(Rn8 of @ERd)←!(Rn8 of @ERd)						4
	BNOT Rn,@aa:8	B					4			(Rn8 of @aa:8)←!(Rn8 of @aa:8)						4
	BNOT Rn,@aa:16	B					6			(Rn8 of @aa:16)←!(Rn8 of @aa:16)						5
BNOT Rn,@aa:32	B					8			(Rn8 of @aa:32)←!(Rn8 of @aa:32)						6	
BTST	BTST #xx:3,Rd	B	2							~(#xx:3 of Rd8)→Z						1
	BTST #xx:3,@ERd	B		4						~(#xx:3 of @ERd)→Z						3
	BTST #xx:3,@aa:8	B					4			~(#xx:3 of @aa:8)→Z						3
	BTST #xx:3,@aa:16	B					6			~(#xx:3 of @aa:16)→Z						4
	BTST #xx:3,@aa:32	B					8			~(#xx:3 of @aa:32)→Z						5
	BTST Rn,Rd	B	2							~(Rn8 of Rd8)→Z						1
	BTST Rn,@ERd	B		4						~(Rn8 of @ERd)→Z						3
	BTST Rn,@aa:8	B					4			~(Rn8 of @aa:8)→Z						3
	BTST Rn,@aa:16	B					6			~(Rn8 of @aa:16)→Z						4
BTST Rn,@aa:32	B					8			~(Rn8 of @aa:32)→Z						5	
BLD	BLD #xx:3,Rd	B	2							(#xx:3 of Rd8)→C						1
	BLD #xx:3,@ERd	B		4						(#xx:3 of @ERd)→C						3
	BLD #xx:3,@aa:8	B					4			(#xx:3 of @aa:8)→C						3
	BLD #xx:3,@aa:16	B					6			(#xx:3 of @aa:16)→C						4
	BLD #xx:3,@aa:32	B					8			(#xx:3 of @aa:32)→C						5
BILD	BILD #xx:3,Rd	B	2							~(#xx:3 of Rd8)→C						1
	BILD #xx:3,@ERd	B		4						~(#xx:3 of @ERd)→C						3
	BILD #xx:3,@aa:8	B					4			~(#xx:3 of @aa:8)→C						3
	BILD #xx:3,@aa:16	B					6			~(#xx:3 of @aa:16)→C						4
	BILD #xx:3,@aa:32	B					8			~(#xx:3 of @aa:32)→C						5
BST	BST #xx:3,Rd	B	2							C→(#xx:3 of Rd8)						1
	BST #xx:3,@ERd	B		4						C→(#xx:3 of @ERd)						4
	BST #xx:3,@aa:8	B					4			C→(#xx:3 of @aa:8)						4
	BST #xx:3,@aa:16	B					6			C→(#xx:3 of @aa:16)						5
	BST #xx:3,@aa:32	B					8			C→(#xx:3 of @aa:32)						6
BIST	BIST #xx:3,Rd	B	2							~C→(#xx:3 of Rd8)						1
	BIST #xx:3,@ERd	B		4						~C→(#xx:3 of @ERd)						4
	BIST #xx:3,@aa:8	B					4			~C→(#xx:3 of @aa:8)						4
	BIST #xx:3,@aa:16	B					6			~C→(#xx:3 of @aa:16)						5
	BIST #xx:3,@aa:32	B					8			~C→(#xx:3 of @aa:32)						6
BAND	BAND #xx:3,Rd	B	2							C^(#xx:3 of Rd8)→C						1
	BAND #xx:3,@ERd	B		4						C^(#xx:3 of @ERd)→C						3
	BAND #xx:3,@aa:8	B					4			C^(#xx:3 of @aa:8)→C						3
	BAND #xx:3,@aa:16	B					6			C^(#xx:3 of @aa:16)→C						4
	BAND #xx:3,@aa:32	B					8			C^(#xx:3 of @aa:32)→C						5

Mnemonic	Size	Addressing Mode and Instruction Length (Bytes)									Operation	Condition Code					No of Execution States *1				
		#xx	Rn	@ERn	@(d,ERn)	@-ERn@ERn+	@aa	@(d,PC)	@aa			I	H	N	Z	V		C			
													Advanced Mode								
BIAND	BIAND #xx:3,Rd	B	2																	1	
	BIAND #xx:3,@ERd	B		4																	3
	BIAND #xx:3,@aa:8	B						4													3
	BIAND #xx:3,@aa:16	B						6													4
	BIAND #xx:3,@aa:32	B						8													5
BOR	BOR #xx:3,Rd	B	2																		1
	BOR #xx:3,@ERd	B		4																	3
	BOR #xx:3,@aa:8	B						4													3
	BOR #xx:3,@aa:16	B						6													4
	BOR #xx:3,@aa:32	B						8													5
BIOR	BIOR #xx:3,Rd	B	2																		1
	BIOR #xx:3,@ERd	B		4																	3
	BIOR #xx:3,@aa:8	B						4													3
	BIOR #xx:3,@aa:16	B						6													4
	BIOR #xx:3,@aa:32	B						8													5
BXOR	BXOR #xx:3,Rd	B	2																		1
	BXOR #xx:3,@ERd	B		4																	3
	BXOR #xx:3,@aa:8	B						4													3
	BXOR #xx:3,@aa:16	B						6													4
	BXOR #xx:3,@aa:32	B						8													5
BIXOR	BIXOR #xx:3,Rd	B	2																		1
	BIXOR #xx:3,@ERd	B		4																	3
	BIXOR #xx:3,@aa:8	B						4													3
	BIXOR #xx:3,@aa:16	B						6													4
	BIXOR #xx:3,@aa:32	B						8													5

## (6) Branch Instructions

Mnemonic	Size	Addressing Mode and Instruction Length (Bytes)										Operation	Operation Code						No of Execution States *1
		#xx	Rn	@ERn	@(d,ERn)	@-ERn/@ERn+	@aa	@(d,PC)	@@aa		Advanced Mode								
													Branch Condition	I	H	N	Z	V	C
Bcc	BRA d:8(BT d:8)	—									2	if condition is true then PC←PC+d else next;	Always	—	—	—	—	—	2
	BRA d:16(BT d:16)	—									4			—	—	—	—	—	3
	BRN d:8(BF d:8)	—									2		Never	—	—	—	—	—	2
	BRN d:16(BF d:16)	—									4			—	—	—	—	—	3
	BHI d:8	—									2		C <sub>v</sub> Z=0	—	—	—	—	—	2
	BHI d:16	—									4			—	—	—	—	—	3
	BLS d:8	—									2		C <sub>v</sub> Z=1	—	—	—	—	—	2
	BLS d:16	—									4			—	—	—	—	—	3
	BCC d:8(BHS d:8)	—									2		C=0	—	—	—	—	—	2
	BCC d:16(BHS d:16)	—									4			—	—	—	—	—	3
	BCS d:8(BLO d:8)	—									2		C=1	—	—	—	—	—	2
	BCS d:16(BLO d:16)	—									4			—	—	—	—	—	3
	BNE d:8	—									2		Z=0	—	—	—	—	—	2
	BNE d:16	—									4			—	—	—	—	—	3
	BEQ d:8	—									2		Z=1	—	—	—	—	—	2
	BEQ d:16	—									4			—	—	—	—	—	3
	BVC d:8	—									2		V=0	—	—	—	—	—	2
	BVC d:16	—									4			—	—	—	—	—	3
	BVS d:8	—									2		V=1	—	—	—	—	—	2
	BVS d:16	—									4			—	—	—	—	—	3
	BPL d:8	—									2		N=0	—	—	—	—	—	2
	BPL d:16	—									4			—	—	—	—	—	3
	BMI d:8	—									2		N=1	—	—	—	—	—	2
	BMI d:16	—									4			—	—	—	—	—	3
	BGE d:8	—									2		N@V=0	—	—	—	—	—	2
	BGE d:16	—									4			—	—	—	—	—	3
	BLT d:8	—									2		N@V=1	—	—	—	—	—	2
	BLT d:16	—									4			—	—	—	—	—	3
	BGT d:8	—									2		Z <sub>v</sub> (N@V)=0	—	—	—	—	—	2
	BGT d:16	—									4			—	—	—	—	—	3
BLE d:8	—									2	Z <sub>v</sub> (N@V)=1	—	—	—	—	—	2		
BLE d:16	—									4		—	—	—	—	—	3		
JMP	JMP @ERn	—			2							PC←ERn	—	—	—	—	—	2	
	JMP @aa:24	—								4		PC←aa:24	—	—	—	—	—	3	
	JMP @@aa:8	—									2	PC←@aa:8	—	—	—	—	—	5	
BSR	BSR d:8	—								2		PC→@-SP,PC←PC+d:8	—	—	—	—	—	4	
	BSR d:16	—								4		PC→@-SP,PC←PC+d:16	—	—	—	—	—	5	
JSR	JSR @ERn	—			2							PC→@-SP,PC←ERn	—	—	—	—	—	4	
	JSR @aa:24	—								4		PC→@-SP,PC←aa:24	—	—	—	—	—	5	
	JSR @@aa:8	—									2	PC→@-SP,PC←@aa:8	—	—	—	—	—	6	
RTS	RTS	—								2		PC←@SP+	—	—	—	—	—	5	

## (7) System Control Instructions

Mnemonic	Size	Addressing Mode and Instruction Length (Bytes)								Operation	Condition Code					No of Execution States *1						
		#xx	Rn	@ERn	@(d,ERn)	@-ERn/@ERn+	@aa	@(d,PC)	@aa			I	H	N	Z		V	C				
													Advanced Mode									
TRAPA	TRAPA #xx:2	—																		8 [9]		
RTE	RTE	—																		5 [9]		
SLEEP	SLEEP	—																		2		
LDC	LDC #xx:8,CCR	B	2																	#xx:8→CCR	1	
	LDC #xx:8,EXR	B	4																	#xx:8→EXR	2	
	LDC Rs,CCR	B		2																Rs8→CCR	1	
	LDC Rs,EXR	B		2																Rs8→EXR	1	
	LDC @ERs,CCR	W			4															@ERs→CCR	3	
	LDC @ERs,EXR	W			4															@ERs→EXR	3	
	LDC @(d:16,ERs),CCR	W				6														@(d:16,ERs)→CCR	4	
	LDC @(d:16,ERs),EXR	W				6														@(d:16,ERs)→EXR	4	
	LDC @(d:32,ERs),CCR	W				10														@(d:32,ERs)→CCR	6	
	LDC @(d:32,ERs),EXR	W				10														@(d:32,ERs)→EXR	6	
	LDC @ERs+,CCR	W					4													@ERs→CCR,ERs32+2→ERs32	4	
	LDC @ERs+,EXR	W					4													@ERs→EXR,ERs32+2→ERs32	4	
	LDC @aa:16,CCR	W						6												@aa:16→CCR	4	
	LDC @aa:16,EXR	W						6												@aa:16→EXR	4	
LDC @aa:32,CCR	W							8											@aa:32→CCR	5		
LDC @aa:32,EXR	W							8											@aa:32→EXR	5		
STC	STC CCR,Rd	B		2																CCR→Rd8	1	
	STC EXR,Rd	B		2																EXR→Rd8	1	
	STC CCR,@ERd	W			4															CCR→@ERd	3	
	STC EXR,@ERd	W			4															EXR→@ERd	3	
	STC CCR,@(d:16,ERd)	W				6														CCR→@(d:16,ERd)	4	
	STC EXR,@(d:16,ERd)	W				6														EXR→@(d:16,ERd)	4	
	STC CCR,@(d:32,ERd)	W				10														CCR→@(d:32,ERd)	6	
	STC EXR,@(d:32,ERd)	W				10														EXR→@(d:32,ERd)	6	
	STC CCR,@-ERd	W					4													ERd32-2→ERd32,CCR→@ERd	4	
	STC EXR,@-ERd	W					4													ERd32-2→ERd32,EXR→@ERd	4	
	STC CCR,@aa:16	W						6												CCR→@aa:16	4	
	STC EXR,@aa:16	W						6												EXR→@aa:16	4	
	STC CCR,@aa:32	W							8											CCR→@aa:32	5	
	STC EXR,@aa:32	W							8											EXR→@aa:32	5	
ANDC	ANDC #xx:8,CCR	B	2																	CCR^#xx:8→CCR	1	
	ANDC #xx:8,EXR	B	4																	EXR^#xx:8→EXR	2	
ORC	ORC #xx:8,CCR	B	2																	CCR∨#xx:8→CCR	1	
	ORC #xx:8,EXR	B	4																	EXR∨#xx:8→EXR	2	
XORC	XORC #xx:8,CCR	B	2																	CCR⊕#xx:8→CCR	1	
	XORC #xx:8,EXR	B	4																	EXR⊕#xx:8→EXR	2	
NOP	NOP	—																		2	PC←PC+2	1

**(8) Block Transfer Instructions**

Mnemonic	Size	Addressing Mode and Instruction Length (Bytes)									Operation	Condition Code					No of Execution States *1		
		#xx	Rn	@ERn	@(d,ERn)	@-ERn@ERn+	@aa	@(d,PC)	@@aa			I	H	N	Z	V		C	
													Advanced Mode						
EEPMOV	EEPMOV.B	—									4	if R4L≠0 Repeat @ER5→@ER6 ER5+1→ER6 ER6+1→ER6 R4L-1→R4L Until R4L=0 else next;	—	—	—	—	—	—	4+2n *3
	EEPMOV.W	—									4	if R4≠0 Repeat @ER5→@ER6 ER5+1→ER5 ER6+1→ER6 R4-1→R4 Until R4=0 else next;	—	—	—	—	—	—	4+2n *3

- Notes:
- The values indicated in the column of number of execution states apply when instruction code and operand exist in the on-chip memory.
  - Only register ER0, ER1, ER4, or ER5 should be used when using the TAS instruction.
  - n is the initial setting value of R4L or R4.
- [1] 7 states when the number of return/retract registers is 2, 9 states when the number of registers is 3, and 11 states when the number of registers is 4.
- [2] Cannot be used in this LSI.
- [3] Set to 1 when a carry or borrow occurs at bit 11, otherwise cleared to 0.
- [4] Set to 1 when a carry or borrow occurs at bit 27, otherwise cleared to 0.
- [5] Retains the value before computation when the computation result is 0, otherwise cleared to 0.
- [6] Set to 1 when the divisor is negative, otherwise cleared to 0.
- [7] Set to 1 when the divisor is 0, otherwise cleared to 0.
- [8] Set to 1 when the quotient is negative, otherwise cleared to 0.
- [9] 1 is added to the number of execution states when EXR is valid.

## A.2 Instruction Codes

Instruction	Mnemonic	Size	Instruction Format																		
			1st byte	2nd byte	3rd byte	4th byte	5th byte	6th byte	7th byte	8th byte	9th byte	10th byte									
ADD	ADD.B #xx:8,Rd	B	8	rd	IMM																
	ADD.B Rs,Rd	B	0	rs	1	rd															
	ADD.W #xx:16,Rd	W	7	9	1	rd	IMM														
	ADD.W Rs,Rd	W	0	9	rs	1	rd														
	ADD.L #xx:32,ERd	L	7	A	1	0:erd				IMM											
	ADD.L ERs,ERd	L	0	A	1	ers:0:erd															
ADDS	ADDS #1,ERd	L	0	B	0	0:erd															
	ADDS #2,ERd	L	0	B	8	0:erd															
	ADDS #4,ERd	L	0	B	9	0:erd															
	ADDS #8,ERd	L	0	B	9	0:erd															
ADDX	ADDX #xx:8,Rd	B	9	rd	IMM																
	ADDX Rs,Rd	B	0	E	rs	rd															
AND	AND.B #xx:8,Rd	B	E	rd	IMM																
	AND.B Rs,Rd	B	1	6	rs	rd															
ANDC	AND.W #xx:16,Rd	W	7	9	6	rd	IMM														
	AND.W Rs,Rd	W	6	6	rs	rd															
	AND.L #xx:32,ERd	L	7	A	6	0:erd			IMM												
	AND.L ERs,ERd	L	0	F	0	6	0:ers:0:erd														
	ANDC #xx:8,CCR	B	0	6	IMM																
	ANDC #xx:8,EXR	B	0	1	4	1	0	6	IMM												
BAND	BAND #xx:3,Rd	B	7	6	0:IMM	rd															
	BAND #xx:3,@ERd	B	7	C	0:erd	0	7	6	0:IMM	0											
	BAND #xx:3,@aa:8	B	7	E	abs	7	6	0:IMM	0												
	BAND #xx:3,@aa:16	B	6	A	1	0	abs														
	BAND #xx:3,@aa:32	B	6	A	3	0	abs														
	BAND #xx:3,@aa:64	B	6	A	3	0	abs														
Bcc	BRA d:8 (BT d:8)	—	4	0	disp																
	BRA d:16 (BT d:16)	—	5	8	0	0	disp														
	BRN d:8 (BF d:8)	—	4	1	disp																
	BRN d:16 (BF d:16)	—	5	8	1	0	disp														
	BHI d:8	—	4	2	disp																
	BHI d:16	—	5	8	2	0	disp														
	BLS d:8	—	4	3	disp																
	BLS d:16	—	5	8	3	0	disp														
	BCC d:8 (BHS d:8)	—	4	4	disp																
	BCC d:16 (BHS d:16)	—	5	8	4	0	disp														
	BCS d:8 (BLO d:8)	—	4	5	disp																
	BCS d:16 (BLO d:16)	—	5	8	5	0	disp														
	BNE d:8	—	4	6	disp																
	BNE d:16	—	5	8	6	0	disp														
	BEQ d:8	—	4	7	disp																
	BEQ d:16	—	5	8	7	0	disp														
BVC d:8	—	4	8	disp																	
BVC d:16	—	5	8	8	0	disp															
BVS d:8	—	4	9	disp																	
BVS d:16	—	5	8	9	0	disp															

Instruction	Mnemonic	Size	Instruction Format																	
			1st byte	2nd byte	3rd byte	4th byte	5th byte	6th byte	7th byte	8th byte	9th byte	10th byte								
Bcc (Cont.)	BPL d:8	—	4	A	disp															
	BPL d:16	—	5	8	A	0	disp													
	BMI d:8	—	4	B	disp															
	BMI d:16	—	5	8	B	0	disp													
	BGE d:8	—	4	C	disp															
	BGE d:16	—	5	8	C	0	disp													
	BLT d:8	—	4	D	disp															
	BLT d:16	—	5	8	D	0	disp													
	BGT d:8	—	4	E	disp															
	BGT d:16	—	5	8	E	0	disp													
BCLR	BLE d:8	—	4	F	disp															
	BLE d:16	—	5	8	F	0	disp													
	BCLR #xx:3,Rd	B	7	2	0:IMM	rd														
	BCLR #xx:3,@ERd	B	7	D	0:errd	0	7	2	0:IMM	0										
	BCLR #xx:3,@aa:8	B	7	F	abs		7	2	0:IMM	0										
	BCLR #xx:3,@aa:16	B	6	A	1	8	abs													
	BCLR #xx:3,@aa:32	B	6	A	3	8	abs													
	BCLR Rn,Rd	B	6	2	rn	rd														
	BCLR Rn,@ERd	B	7	D	0:errd	0	6	2	rn	0										
	BCLR Rn,@aa:8	B	7	F	abs		6	2	rn	0										
BIAND	BCLR Rn,@aa:16	B	6	A	1	8	abs													
	BCLR Rn,@aa:32	B	6	A	3	8	abs													
	BIAND #xx:3,Rd	B	7	6	1:IMM	rd														
	BIAND #xx:3,@ERd	B	7	C	0:errd	0	7	6	1:IMM	0										
	BIAND #xx:3,@aa:8	B	7	E	abs		7	6	1:IMM	0										
	BIAND #xx:3,@aa:16	B	6	A	1	0	abs													
	BIAND #xx:3,@aa:32	B	6	A	3	0	abs													
	BILD #xx:3,Rd	B	7	7	1:IMM	rd														
	BILD #xx:3,@ERd	B	7	C	0:errd	0	7	7	1:IMM	0										
	BILD #xx:3,@aa:8	B	7	E	abs		7	7	1:IMM	0										
BIOR	BILD #xx:3,@aa:16	B	6	A	1	0	abs													
	BILD #xx:3,@aa:32	B	6	A	3	0	abs													
	BIOR #xx:3,Rd	B	7	4	1:IMM	rd														
	BIOR #xx:3,@ERd	B	7	C	0:errd	0	7	4	1:IMM	0										
	BIOR #xx:3,@aa:8	B	7	E	abs		7	4	1:IMM	0										
	BIOR #xx:3,@aa:16	B	6	A	1	0	abs													
	BIOR #xx:3,@aa:32	B	6	A	3	0	abs													
	BIST #xx:3,Rd	B	6	7	1:IMM	rd														
	BIST #xx:3,@ERd	B	7	D	0:errd	0	6	7	1:IMM	0										
	BIST #xx:3,@aa:8	B	7	F	abs		6	7	1:IMM	0										

Instruction	Mnemonic	Op-Size	Instruction Format																	
			1st byte	2nd byte	3rd byte	4th byte	5th byte	6th byte	7th byte	8th byte	9th byte	10th byte								
BIXOR	BIXOR #xx:3,Rd	B	7	5	1:IMM# rd															
	BIXOR #xx:3,@ERd	B	7	C	0:erd	0	7	5	1:IMM# 0											
	BIXOR #xx:3,@aa:8	B	7	E	abs															
	BIXOR #xx:3,@aa:16	B	6	A	1	0	0	7	5	1:IMM# 0										
	BIXOR #xx:3,@aa:32	B	6	A	3	0	0	abs												
	BIXOR #xx:3,Rd	B	7	7	0:IMM# rd															
BLD	BLD #xx:3,@ERd	B	7	C	0:erd	0	7	7	0:IMM# 0											
	BLD #xx:3,@aa:8	B	7	E	abs															
	BLD #xx:3,@aa:16	B	6	A	1	0	0	abs												
	BLD #xx:3,@aa:32	B	6	A	3	0	0	abs												
	BLD #xx:3,Rd	B	7	1	0:IMM# rd															
	BLD #xx:3,@ERd	B	7	D	0:erd	0	7	1	0:IMM# 0											
BNOT	BNOT #xx:3,Rd	B	7	F	abs															
	BNOT #xx:3,@aa:8	B	7	F	abs															
	BNOT #xx:3,@aa:16	B	6	A	1	8	0	abs												
	BNOT #xx:3,@aa:32	B	6	A	3	8	0	abs												
	BNOT Rn,Rd	B	6	1	rd															
	BNOT Rn,@ERd	B	7	D	0:erd	0	6	1	rd	0										
BOR	BNOT Rn,@aa:8	B	7	F	abs															
	BNOT Rn,@aa:16	B	6	A	1	8	0	abs												
	BNOT Rn,@aa:32	B	6	A	3	8	0	abs												
	BOR #xx:3,Rd	B	7	4	0:IMM# rd															
	BOR #xx:3,@ERd	B	7	C	0:erd	0	7	4	0:IMM# 0											
	BOR #xx:3,@aa:8	B	7	E	abs															
BSET	BOR #xx:3,@aa:16	B	6	A	1	0	0	abs												
	BOR #xx:3,@aa:32	B	6	A	3	0	0	abs												
	BSET #xx:3,Rd	B	7	0	0:IMM# rd															
	BSET #xx:3,@ERd	B	7	D	0:erd	0	7	0	0:IMM# 0											
	BSET #xx:3,@aa:8	B	7	F	abs															
	BSET #xx:3,@aa:16	B	6	A	1	8	0	abs												
BSR	BSET #xx:3,@aa:32	B	6	A	3	8	0	abs												
	BSET Rn,Rd	B	6	0	rd															
	BSET Rn,@ERd	B	7	D	0:erd	0	6	0	rd	0										
	BSET Rn,@aa:8	B	7	F	abs															
	BSET Rn,@aa:16	B	6	A	1	8	0	abs												
	BSET Rn,@aa:32	B	6	A	3	8	0	abs												
BST	BSR d:8	—	5	5	disp															
	BSR d:16	—	5	C	0	0	0	disp												
	BST #xx:3,Rd	B	6	7	0:IMM# rd															
	BST #xx:3,@ERd	B	7	D	0:erd	0	6	7	0:IMM# 0											
	BST #xx:3,@aa:8	B	7	F	abs															
	BST #xx:3,@aa:16	B	6	A	1	8	0	abs												
BST #xx:3,@aa:32	B	6	A	3	8	0	abs													





Instruction	Mnemonic	Size	Instruction Format																		
			1st byte	2nd byte	3rd byte	4th byte	5th byte	6th byte	7th byte	8th byte	9th byte	10th byte									
BTST	BTST #xx:3,Rd	B	7	3	0:IMM#	rd															
	BTST #xx:3,@ERd	B	7	C	0:erd	0	7	3	0:IMM#	0											
	BTST #xx:3,@aa:8	B	7	E	abs	7	3	0:IMM#	0												
	BTST #xx:3,@aa:16	B	6	A	1	0	abs														
	BTST #xx:3,@aa:32	B	6	A	3	0	abs														
	BTST Rn,Rd	B	6	3	rn	rd															
BXOR	BTST Rn,@ERd	B	7	C	0:erd	0	6	3	rn	0											
	BTST Rn,@aa:8	B	7	E	abs	6	3	rn	0												
	BTST Rn,@aa:16	B	6	A	1	0	abs														
	BTST Rn,@aa:32	B	6	A	3	0	abs														
	BXOR #xx:3,Rd	B	7	5	0:IMM#	rd															
	BXOR #xx:3,@ERd	B	7	C	0:erd	0	7	5	0:IMM#	0											
CLRMAC	BXOR #xx:3,@aa:8	B	7	E	abs	7	5	0:IMM#	0												
	BXOR #xx:3,@aa:16	B	6	A	1	0	abs														
	BXOR #xx:3,@aa:32	B	6	A	3	0	abs														
	CLRMAC	—	Cannot be used in this LSI																		
	CMP	CMP.B #xx:8,Rd	B	A	rd	IMM															
	DIVXS	CMP.B Rs,Rd	B	1	C	rs	rd														
CMP.W #xx:16,Rd		W	7	9	2	rd	IMM														
CMP.W Rs,Rd		W	1	D	rs	rd															
CMP.L #xx:32,ERd		L	7	A	2	0:erd															
CMP.L ERs,ERd		L	1	F	1:ers	0:erd															
DAA Rd		B	0	F	0	rd															
DAS Rd		B	1	F	0	rd															
DEC		DEC.B Rd	B	1	A	0	rd														
DIVXU		DEC.W #1,Rd	W	1	B	5	rd														
		DEC.W #2,Rd	W	1	B	D	rd														
DIVXS	DECL.#1,ERd	L	1	B	7	0:erd															
	DECL.#2,ERd	L	1	B	F	0:erd															
DIVXU	DIVXSB Rs,Rd	B	0	1	D	0	5	1	rs	rd											
	DIVXUB Rs,Rd	W	0	1	D	0	5	3	rs	0:erd											
EEPMOV	DIVXUB Rs,ERd	B	5	1	rs	rd															
	DIVXUW Rs,ERd	W	5	3	rs	0:erd															
EXTS	EEPMOV.B	—	7	B	5	C	5	9	8	F											
	EEPMOV.W	—	7	B	D	4	5	9	8	F											
EXTU	EXTS.W Rd	W	1	7	D	rd															
	EXTS.L ERd	L	1	7	F	0:erd															
EXTULL ERd	EXTU.W Rd	W	1	7	5	rd															
	EXTULL ERd	L	1	7	7	0:erd															



Instruction	Mnemonic	Instruction Format																			
		1st byte	2nd byte	3rd byte	4th byte	5th byte	6th byte	7th byte	8th byte	9th byte	10th byte										
MOV (Cont.)	MOV.B Rs,@ERd	B	6	C	1:erd	rs															
	MOV.B Rs,aa:16	B	3	rs	abs																
	MOV.B Rs,aa:32	B	6	A	A	8	rs	abs													
	MOV.W #xxx:16,Rd	W	7	9	0	rd	IMM														
	MOV.W @ERs,Rd	W	6	D	rs	rd															
	MOV.W @ERS,Rd	W	6	9	0:ers	rd															
	MOV.W @(d:16,ERs),Rd	W	6	F	0:ers	rd	disp														
	MOV.W @(d:32,ERs),Rd	W	7	8	0:ers	0	6	2	rd	disp											
	MOV.W @ERs+,Rd	W	6	D	0:ers	rd															
	MOV.W @aa:16,Rd	W	6	B	0	rd	abs														
	MOV.W @aa:32,Rd	W	6	B	2	rd	abs														
	MOV.W Rs,@ERd	W	6	9	1:erd	rs															
	MOV.W Rs,(d:16,ERd)	W	6	F	1:erd	rs	disp														
	MOV.W Rs,(d:32,ERd)	W	7	8	0:erd	0	6	A	rs	disp											
	MOV.W Rs,@ERd	W	6	D	1:erd	rs															
	MOV.W Rs,aa:16	W	6	B	8	rs	abs														
	MOV.W Rs,aa:32	W	6	B	A	rs	abs														
	MOV.L #xx:32,Rd	W	7	A	0	0:erd	IMM														
	MOV.L ERs,ERd	L	0	F	1:ers	0:erd															
	MOV.L @ERs,ERd	L	0	1	0	0	6	9	0:ers	0:erd											
MOV.L @(d:16,ERs),ERd	L	0	1	0	0	6	F	0:ers	0:erd	disp											
MOV.L (d:32,ERs),ERd	L	0	1	0	0	7	8	0:ers	0	6	2	0:erd	disp								
MOV.L @ERs+,ERd	L	0	1	0	0	6	D	0:ers	0:erd												
MOV.L @aa:16,ERd	L	0	1	0	0	6	B	0	0:erd	abs											
MOV.L @aa:32,ERd	L	0	1	0	0	6	B	2	0:erd	abs											
MOV.L ERs,@ERd	L	0	1	0	0	6	9	1:erd	0:ers												
MOV.L ERs,(d:16,ERd)	L	0	1	0	0	6	F	1:erd	0:ers	disp											
MOV.L ERs,(d:32,ERd)*1	L	0	1	0	0	7	8	0:erd	0	6	A	0:ers	disp								
MOV.L ERs,@ERd	L	0	1	0	0	6	D	1:erd	0:ers												
MOV.L ERs,aa:16	L	0	1	0	0	6	B	8	0:ers	abs											
MOV.L ERs,aa:32	L	0	1	0	0	6	B	A	0:ers	abs											
MOV.FPE @aa:16,Rd	B	Cannot be used in this LSI																			
MOV.TPE	B	MOV.TPE Rs,@aa:16																			
MULXS	B	0	1	C	0	5	0	rs	rd												
MULXS.W Rs,Rd	W	0	1	C	0	5	2	rs	0:erd												
MULXU	B	5	0	rs	rd																
MULXU.W Rs,Rd	W	5	2	rs	0:erd																
NEG	B	1	7	8	rd																
NEG.W Rd	W	1	7	9	rd																
NEG.L ERd	L	1	7	B	0:erd																
NOP	NOP	—	0	0	0	0															

Instruction	Mnemonic	Op Size	Instruction Format																	
			1st byte	2nd byte	3rd byte	4th byte	5th byte	6th byte	7th byte	8th byte	9th byte	10th byte								
NOT	NOT.B Rd	B	1	7	0	rd														
	NOT.W Rd	W	1	7	1	rd														
	NOT.L ERd	L	1	7	3	:0:erd														
OR	OR.B #xxx:8,Rd	B	C	rd	IMM															
	OR.B Rs,Rd	B	1	4	rs	rd														
	OR.W #xx:16,Rd	W	7	9	4	rd														
	OR.W Rs,Rd	W	6	4	rs	rd														
	OR.L #xx:32,ERd	L	7	A	4	:0:erd														
ORC	OR.L ERs,ERd	L	0	1	F	0	6	:4	0	:ers:	0	:erd								
	ORC #xx:8,CCR	B	0	4	IMM															
POP	ORC #xx:8,EXR	B	0	1	4	1	0	:4	IMM											
	POP.W Rn	W	6	D	7	m														
PUSH	POP.L ERn	L	0	1	0	0	6	:D	7	:0:ern										
	PUSH.W Rn	W	6	D	F	m														
	PUSH.L ERn	L	0	1	0	0	6	:D	F	:0:ern										
ROT	ROT.L B Rd	B	1	2	8	rd														
	ROT.L B #2, Rd	B	1	2	C	rd														
	ROT.L W Rd	W	1	2	9	rd														
	ROT.L W #2, Rd	W	1	2	D	rd														
	ROT.L L ERd	L	1	2	B	:0:erd														
	ROT.L L #2, ERd	L	1	2	F	:0:erd														
	ROT.R B Rd	B	1	3	8	rd														
	ROT.R B #2, Rd	B	1	3	C	rd														
	ROT.R W Rd	W	1	3	9	rd														
	ROT.R W #2, Rd	W	1	3	D	rd														
ROTR	ROTR.L ERd	L	1	3	B	:0:erd														
	ROTR.L #2, ERd	L	1	3	F	:0:erd														
	ROTX.L B Rd	B	1	2	0	rd														
	ROTX.L B #2, Rd	B	1	2	4	rd														
	ROTX.L W Rd	W	1	2	1	rd														
ROTXR	ROTX.L W #2, Rd	W	1	2	5	rd														
	ROTX.L L ERd	L	1	2	3	:0:erd														
	ROTX.L L #2, ERd	L	1	2	7	:0:erd														
	ROTXR.B Rd	B	1	3	0	rd														
	ROTXR.B #2, Rd	B	1	3	4	rd														
	ROTXR.W Rd	W	1	3	1	rd														
RTE	ROTXR.W #2, Rd	W	1	3	5	rd														
	ROTXR.L ERd	L	1	3	3	:0:erd														
	ROTXR.L #2, ERd	L	1	3	7	:0:erd														
	RTE	—	5	6	7	0														
RTS	—	5	4	7	0															



Instruction	Mnemonic	Size	Instruction Format																	
			1st byte	2nd byte	3rd byte	4th byte	5th byte	6th byte	7th byte	8th byte	9th byte	10th byte								
SHAL	SHAL.B Rd	B	1	0	8	rd														
	SHAL.B #2, Rd	B	1	0	C	rd														
	SHAL.W Rd	W	1	0	9	rd														
	SHAL.W #2, Rd	W	1	0	D	rd														
	SHAL.L ERd	L	1	0	B	0:erd														
	SHAL.L #2, ERd	L	1	0	F	0:erc														
SHAR	SHAR.B Rd	B	1	1	8	rd														
	SHAR.B #2, Rd	B	1	1	C	rd														
	SHAR.W Rd	W	1	1	9	rd														
	SHAR.W #2, Rd	W	1	1	D	rd														
	SHAR.L ERd	L	1	1	B	0:erd														
	SHAR.L #2, ERd	L	1	1	F	0:erc														
SHLL	SHLL.B Rd	B	1	0	0	rd														
	SHLL.B #2, Rd	B	1	0	4	rd														
	SHLL.W Rd	W	1	0	1	rd														
	SHLL.W #2, Rd	W	1	0	5	rd														
	SHLL.L ERd	L	1	0	3	0:erc														
	SHLL.L #2, ERd	L	1	0	7	0:erc														
SHLR	SHLR.B Rd	B	1	1	0	rd														
	SHLR.B #2, Rd	B	1	1	4	rd														
	SHLR.W Rd	W	1	1	1	rd														
	SHLR.W #2, Rd	W	1	1	5	rd														
	SHLR.L ERd	L	1	1	3	0:erc														
	SHLR.L #2, ERd	L	1	1	7	0:erc														
STC	SLEEP	—	0	1	8	0														
	STC.B CCR, Rd	B	0	2	0	rd														
	STC.B EXR, Rd	B	0	2	1	rd														
	STC.W CCR, @ERd	W	0	1	4	0	6	9	1:erd	0										
	STC.W EXR, @ERd	W	0	1	4	1	6	9	1:erd	0										
	STC.W CCR, @(d:16,ERd)	W	0	1	4	0	6	F	1:erd	0										
	STC.W EXR, @(d:16,ERd)	W	0	1	4	1	6	F	1:erd	0										
	STC.W CCR, @(d:32,ERd)	W	0	1	4	0	7	8	0:erd	0	6	B	A	0						
	STC.W EXR, @(d:32,ERd)	W	0	1	4	1	7	8	0:erd	0	6	B	A	0						
	STC.W CCR, @-ERd	W	0	1	4	0	6	D	1:erd	0										
	STC.W EXR, @-ERd	W	0	1	4	1	6	D	1:erd	0										
	STC.W CCR, @aa:16	W	0	1	4	0	6	B	8	0										
	STC.W EXR, @aa:16	W	0	1	4	1	6	B	8	0										
	STC.W CCR, @aa:32	W	0	1	4	0	6	B	A	0										
STC.W EXR, @aa:32	W	0	1	4	1	6	B	A	0											
STM	STM.L (ERn-ERn+1), @-SP	L	0	1	1	0	6	D	F	0:ern										
	STM.L (ERn-ERn+2), @-SP	L	0	1	2	0	6	D	F	0:ern										
	STM.L (ERn-ERn+3), @-SP	L	0	1	3	0	6	D	F	0:ern										
	STM.L (ERn-ERn+3), @-SP	L	0	1	3	0	6	D	F	0:ern										
STMAC	STMAC.MACH, ERd	L	Cannot be used in this LSI																	
	STMAC.MAC, LERd	L																		

Instruction	Mnemonic	Op code	Instruction Format																	
			1st byte	2nd byte	3rd byte	4th byte	5th byte	6th byte	7th byte	8th byte	9th byte	10th byte								
SUB	SUB.B Rs,Rd	B	1	8	rs	rd														
	SUB.W #xx:16,Rd	W	7	9	3	rd	IMM													
	SUB.W Rs,Rd	W	1	9	rs	rd														
	SUB.L #xx:32,ERd	L	7	A	3	0:erd		IMM												
	SUB.L ERs,ERd	L	1	A	1	ers:0:erd														
SUBS	SUBS #1,ERd	L	1	B	0	0:erd														
	SUBS #2,ERd	L	1	B	8	0:erd														
	SUBS #4,ERd	L	1	B	9	0:erd														
	SUBS #x:8,Rd	B	B	rd	IMM															
TAS <sup>*2</sup>	SUBX Rs,Rd	B	1	E	rs	rd														
	TAS @ERd	B	0	1	E	0	7	B	0:erd	C										
TRAPA	TRAPA #x:2	—	5	7	00:IMM	0														
	XOR	B	D	rd	IMM															
XORL	XORL Rs,Rd	B	1	5	rs	rd														
	XORL.W #xx:16,Rd	W	7	9	5	rd	IMM													
	XORL.W Rs,Rd	W	6	5	rs	rd														
	XORL #xx:32,ERd	L	7	A	5	0:erd														
	XORL ERs,ERd	L	0	1	F	0	6	5	0:ers:0:erd											
XORC	XORC #xx:8,CCR	B	0	5	IMM															
	XORC #xx:8,EXR	B	0	1	4	1	0	5	IMM											

- Notes:
1. Either 1 or 0 can be set to bit 7 in 4th byte of MOV.L ERs, @ (d: 32, ERd) instruction.
  2. Only register ER0,ER1,ER4, or ER5 should be used when using the TAS instruction.

Legend:

IMM: Immediate data (2, 3, 8, 16, 32 bits)

abs: Absolute address (8, 16, 24, 32 bits)

disp: Displacement (8, 16, 32 bits)

rs, rd, rn: Register fields (8-bit register or 16-bit register is selected in 4 bits. rs, rd and rn correspond to the operand type Rs, Rd, and Rn respectively.)

ers, erd, ern, erm: Register fields (address register or 32-bit register is selected in 3 bits. ers, erd, ern and erm correspond to the operand type ERs, ERd, ERn and Rm respectively.)

The following table shows the correspondence between the register field and the general register.

**Address Register, 32-bit Register**

<b>Address Register, 32-bit Register</b>		<b>16-bit Register</b>		<b>8-bit Register</b>	
<b>Register Field</b>	<b>General Register</b>	<b>Register Field</b>	<b>General Register</b>	<b>Register Field</b>	<b>General Register</b>
000	ER0	0000	R0	0000	R0H
001	ER1	0001	R1	0001	R1H
:	:	:	:	:	:
:	:	:	:	:	:
:	:	:	:	:	:
:	:	:	:	:	:
111	ER7	0111	R7	0111	R7H
		1000	E0	1000	R0L
		1001	E1	1001	R1L
		:	:	:	:
		:	:	:	:
		:	:	:	:
		:	:	:	:
		1111	E7	1111	R7L

### A.3 Operation Code Map

Table A.3 shows an operation code map.

**Table A.3 Operation Code Map**

Instruction code:

1st byte		2nd byte	
AH	AL	BH	BL

AL	0	1	2	3	4	5	6	7	8	9	A	B	C	D	E	F
AH	NOP	STC Table A.3(2)	LDC Table A.3(2)	ORC Table A.3(2)	ORC Table A.3(2)	XORC Table A.3(2)	ANDC Table A.3(2)	LDC Table A.3(2)	ADD Table A.3(2)	ADD Table A.3(2)	Table A.3(2)	Table A.3(2)	Table A.3(2)	MOV Table A.3(2)	ADDD Table A.3(2)	Table A.3(2)
	1			OR	OR	XOR	AND	AND	SUB	SUB	Table A.3(2)	Table A.3(2)	OMP	OMP	SUBX	Table A.3(2)
	2	MOV.B														
	3															
	4	BRA	BRN	BHI	BLS	BCC	BNE	BEQ	BVC	BVS	BPL	BMI	BGE	BLT	BGT	BLE
	5	MULXU	DIVXU	MULXU	DIVXU	RTS	RTE	TRAPA	Table A.3(2)		JMP	BSR	BSR		JSR	
	6	BSET	BNOT	BCLR	BTST	OR	AND	BST	BAND	MOV	Table A.3(2)	Table A.3(2)		MOV		
	7					BIOR	BAND	BLD	BIAND	MOV	Table A.3(2)	EEP	MOV			Table A.3(3)
	8	ADD														
	9	ADDD														
	A	CMP														
	B	SUBX														
	C	OR														
	D	XOR														
	E	AND														
	F	MOV														

Note: \* Cannot be used in this LSI.

Rev.3.00 Jan. 10, 2007 page 868 of 1038

REJ09B0328-0300



Instruction code:

1st byte		2nd byte	
AH	AL	BH	BL

BH	AH	AL	0	1	2	3	4	5	6	7	8	9	A	B	C	D	E	F
			MOV	LDM	STM	LDC	STC		MAC*		SLEEP		CLFIMAC*		Table A.3(3)	Table A.3(3)	TAS	Table A.3(3)
0A			INC												ADD			
0B			ADDS					INC		INC	ADDS					INC		INC
0F			DAA												MOV			
10			SHLL			SHLL				SHLL	SHAL				SHAL			SHAL
11			SHLR			SHLR				SHLR	SHAR				SHAR			SHAR
12			ROTXL			ROTXL				ROTXL	ROTL				ROTL			ROTL
13			ROTXR			ROTXR				ROTXR	ROTR				ROTR			ROTR
17			NOT			NOT		EXTU		EXTU	NEG			NEG		EXTS		EXTS
1A			DEC												SUB			
1B			SUBS					DEC		DEC	SUBS					DEC		DEC
1F			DAS												CMP			
58			BRA	BRN	BHI	BLS	BCC	BCS	BNE	BEQ	BVC	BVS	BPL	BMI	BGE	BLT	BGT	BLE
6A			MOV	Table A.3(4)	MOV	Table A.3(4)	MOVFP*				MOV		MOV		MOVTP*			
79			MOV	ADD	CMP	SUB	OR	XOR	AND									
7A			MOV	ADD	CMP	SUB	OR	XOR	AND									

Note: \* Cannot be used in this LSI.

1st byte		2nd byte		3rd byte		4th byte	
AH	AL	BH	BL	CH	CL	DH	DL



Instruction code:

CL	0	1	2	3	4	5	6	7	8	9	A	B	C	D	E	F
AH, AL, BH, CH	MULXS	MULXS	MULXS													
01C05																
01D05		DIVXS		DIVXS												
01F06					OR	XOR	AND									
7C06 *1																
7C07 *1				BTST												
7D06 *1	BSET	BNOT	BCLR													
7D07 *1	BSET	BNOT	BCLR													
7Eaa6 *2																
7Eaa7 *2				BTST												
7Faa6 *2	BSET	BNOT	BCLR													
7Faa7 *2	BSET	BNOT	BCLR													

- Notes:
1. r is the register specification section.
  2. Absolute address is set at aa.

Instruction code:

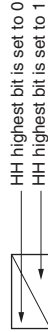
1st byte		2nd byte		3rd byte		4th byte		5th byte		6th byte	
AH	AL	BH	BL	CH	CL	DH	DL	EH	EL	FH	FL



<del>EL</del> AHALBHBLCHCLDHLDELH	0	1	2	3	4	5	6	7	8	9	A	B	C	D	E	F
6A10aaaa6*				BTST												
6A10aaaa7*				<del>                     BOR                      BIOR                 </del>	<del>                     BXOR                      BIXOR                 </del>	<del>                     BAND                      BIAND                 </del>	<del>                     BLD                      BILD                 </del>	<del>                     BST                      BIST                 </del>								
6A18aaaa6*																
6A18aaaa7*																
	BSET	BNOT	BCLR													

Instruction code:

1st byte		2nd byte		3rd byte		4th byte		5th byte		6th byte		7th byte		8th byte	
AH	AL	BH	BL	CH	CL	DH	DL	EH	EL	FH	FL	GH	GL	HH	HL



<del>GL</del> AHALHBL...FHLGH	0	1	2	3	4	5	6	7	8	9	A	B	C	D	E	F
6A30aaaaaa6*																
6A30aaaaaaa7*				BTST												
6A38aaaaaaa6*				<del>                     BOR                      BIOR                 </del>	<del>                     BXOR                      BIXOR                 </del>	<del>                     BAND                      BIAND                 </del>	<del>                     BLD                      BILD                 </del>	<del>                     BST                      BIST                 </del>								
6A38aaaaaaa7*																
	BSET	BNOT	BCLR													

Note: \* Absolute address is set at aa.

## A.4 Number of Execution States

This section explains execution state and how to calculate the number of execution states for each instruction of the H8S/2000 CPU.

Table A.5 indicates number of cycles of instruction fetch and data read/write during instruction execution, and table A.4 indicates number of states required for each instruction size.

The number of execution states can be obtained from the equation below.

$$\text{Number of execution states} = I \cdot S_I + J \cdot S_J + K \cdot S_K + L \cdot S_L + M \cdot S_M + N \cdot S_N$$

---

### Examples of execution state number calculation

The conditions are as follows: In advanced mode, program and stack areas are set in the on-chip memory, a wait is inserted every 2 states in the on-chip supporting module access with 8-bit bus width.

1. BSET #0, @FFFC7:8

From table A.5,

$$I = L = 2, J = K = M = N = 0$$

From table A.4,

$$S_I = 1, S_L = 2$$

$$\text{Number of execution states} = 2 \times 1 + 2 \times 2 = 6$$

2. JSR @@30

From table A.5,

$$I = J = K = 2, L = M = N = 0$$

From table A.4,

$$S_I = S_J = S_K = 1$$

$$\text{Number of execution states} = 2 \times 1 + 2 \times 1 + 2 \times 1 = 6$$

**Table A.4** Number of States Required for Each Execution Status (Cycle)

Execution Status (Cycle)	Target of Access		
	On-Chip Memory	On-Chip Supporting Module	
		8-Bit Bus	16-Bit Bus
Instruction fetch $S_I$	1	—	—
Branch address read $S_J$			
Stack operation $S_K$			
Byte data access $S_L$		2	2
Word data access $S_M$		4	2
Internal operation $S_N$	1	1	1

Table A.5 Instruction Execution Status (No. of Cycles)

Instruction Mnemonic		Branch			Word		Internal Operation
		Instruction Fetch	Address Read	Stack Operation	Byte Data Access	Data Access	
		I	J	K	L	M	N
ADD	ADD.B #xx:8,Rd	1					
	ADD.B Rs, Rd	1					
	ADD.W #xx:16,Rd	2					
	ADD.W Rs,Rd	1					
	ADD.L #xx:32,ERd	3					
	ADD.L ERs,ERd	1					
ADDS	ADDS #1/2/4,ERd	1					
ADDX	ADDX #xx:8,Rd	1					
	ADDX Rs,Rd	1					
AND	AND.B #xx:8,Rd	1					
	AND.B Rs,Rd	1					
	AND.W #xx:16,Rd	2					
	AND.W Rs,Rd	1					
	AND.L #xx:32,ERd	3					
	AND.L ERs,ERd	2					
ANDC	ANDC #xx:8,CCR	1					
	ANDC #xx:8,EXR	2					
BAND	BAND #xx:3,Rd	1					
	BAND #xx:3,@ERd	2			1		
	BAND #xx:3@aa:8	2			1		
	BAND #xx:3@aa:16	3			1		
	BAND #xx:3@aa:32	4			1		
	Bcc	BRA d:8 (BT d:8)	2				
BRN d:8 (BF d:8)		2					
BHI d:8		2					
BLS d:8		2					
BCC d:8 (BHS d:8)		2					
BCS d:8 (BLO d:8)		2					
BNE d:8		2					
BEQ d:8		2					
BVC d:8		2					
BVS d:8		2					
BPL d:8		2					
BMI d:8		2					
BGE d:8		2					
BLT d:8		2					
BGT d:8		2					
BLE d:8		2					
BRA d:16 (BT d:16)		2					1
BRN d:16 (BF d:16)		2					1
BHI d:16		2					1
BLS d:16		2					1

Instruction	Mnemonic	Instruction	Branch	Stack	Word		Internal
		Fetch	Address		Byte	Data	
		I	J	K	L	M	N
Bcc	BCC d:16 (BHS d:16)	2					1
	BCS d:16 (BLO d:16)	2					1
	BNE d:16	2					1
	BEQ d:16	2					1
	BVC d:16	2					1
	BVS d:16	2					1
	BPL d:16	2					1
	BMI d:16	2					1
	BGE d:16	2					1
	BLT d:16	2					1
BGT d:16	2					1	
BLE d:16	2					1	
BCLR	BCLR #xx:3,Rd	1					
	BCLR #xx:3,@ERd	2			2		
	BCLR #xx:3,@aa:8	2			2		
	BCLR #xx:3,@aa:16	3			2		
	BCLR #xx:3,@aa:32	4			2		
	BCLR Rn,Rd	1					
	BCLR Rn,@ERd	2			2		
	BCLR Rn,@aa:8	2			2		
	BCLR Rn,@aa:16	3			2		
BCLR Rn,@aa:32	4			2			
BIAND	BIAND #xx:3,Rd	1					
	BIAND #xx:3,@ERd	2			1		
	BIAND #xx:3,@aa:8	2			1		
	BIAND #xx:3,@aa:16	3			1		
	BIAND #xx:3,@aa:32	4			1		
BILD	BILD #xx:3,Rd	1					
	BILD #xx:3,@ERd	2			1		
	BILD #xx:3,@aa:8	2			1		
	BILD #xx:3,@aa:16	3			1		
	BILD #xx:3,@aa:32	4			1		
BIOR	BIOR #xx:8,Rd	1					
	BIOR #xx:8,@ERd	2			1		
	BIOR #xx:8,@aa:8	2			1		
	BIOR #xx:8,@aa:16	3			1		
	BIOR #xx:8,@aa:32	4			1		
BIST	BIST #xx:3,Rd	1					
	BIST #xx:3,@ERd	2			2		
	BIST #xx:3,@aa:8	2			2		
	BIST #xx:3,@aa:16	3			2		
	BIST #xx:3,@aa:32	4			2		

Instruction Mnemonic		Branch			Word		Internal Operation
		Instruction Fetch	Address Read	Stack Operation	Byte Data Access	Data Access	
		I	J	K	L	M	N
BIXOR	BIXOR #xx:3,Rd	1					
	BIXOR #xx:3,@ERd	2			1		
	BIXOR #xx:3,@aa:8	2			1		
	BIXOR #xx:3,@aa:16	3			1		
	BIXOR #xx:3,@aa:32	4			1		
BLD	BLD #xx:3,Rd	1					
	BLD #xx:3,@ERd	2			1		
	BLD #xx:3,@aa:8	2			1		
	BLD #xx:3,@aa:16	3			1		
	BLD #xx:3,@aa:32	4			1		
BNOT	BNOT #xx:3,Rd	1					
	BNOT #xx:3,@ERd	2			2		
	BNOT #xx:3,@aa:8	2			2		
	BNOT #xx:3,@aa:16	3			2		
	BNOT #xx:3,@aa:32	4			2		
	BNOT Rn,Rd	1					
	BNOT Rn,@ERd	2			2		
	BNOT Rn,@aa:8	2			2		
BNOT Rn,@aa:16	3			2			
BNOT	BNOT Rn,@aa:32	4			2		
BOR	BOR #xx:3,Rd	1					
	BOR #xx:3,@ERd	2			1		
	BOR #xx:3,@aa:8	2			1		
	BOR #xx:3,@aa:16	3			1		
	BOR #xx:3,@aa:32	4			1		
BSET	BSET #xx:3,Rd	1					
	BSET #xx:3,@ERd	2			2		
	BSET #xx:3,@aa:8	2			2		
	BSET #xx:3,@aa:16	3			2		
	BSET #xx:3,@aa:32	4			2		
	BSET Rn,Rd	1					
	BSET Rn,@ERd	2			2		
	BSET Rn,@aa:8	2			2		
	BSET Rn,@aa:16	3			2		
BSET Rn,@aa:32	4			2			
BSR	BSR d:8	2		2			
	BSR d:16	2		2			1
BST	BST #xx:3,Rd	1					
	BST #xx:3,@ERd	2			2		
	BST #xx:3,@aa:8	2			2		
	BST #xx:3,@aa:16	3			2		
	BST #xx:3,@aa:32	4			2		



Instruction	Mnemonic	Instruction Fetch	Branch	Stack Operation	Word		Internal Operation
			Address Read		Byte Access	Data Access	
		I	J	K	L	M	N
BTST	BTST #xx:3,Rd	1					
	BTST #xx:3,@ERd	2			1		
	BTST #xx:3,@aa:8	2			1		
	BTST #xx:3,@aa:16	3			1		
	BTST #xx:3,@aa:32	4			1		
	BTST Rn,Rd	1					
	BTST Rn,@ERd	2				1	
	BTST Rn,@aa:8	2				1	
	BTST Rn,@aa:16	3				1	
BTST Rn,@aa:32	4				1		
BXOR	BXOR #xx:3,Rd	1					
	BXOR #xx:3,@ERd	2			1		
	BXOR #xx:3,@aa:8	2			1		
	BXOR #xx:3,@aa:16	3			1		
	BXOR #xx:3,@aa:32	4			1		
CLRMAC	CLRMAC	Cannot be used in this LSI.					
CMP	CMP.B #xx:8,Rd	1					
	CMP.B Rs,Rd	1					
	CMP.W #xx:16,Rd	2					
	CMP.W Rs,Rd	1					
	CMP.L #xx:32,ERd	3					
	CMP.L ERs,ERd	1					
DAA	DAA Rd	1					
DAS	DAS Rd	1					
DEC	DEC.B Rd	1					
	DEC.W #1/2,Rd	1					
	DEC.L #1/2 ERd	1					
DIVXS	DIVXS.B Rs,Rd	2					11
	DIVXS.W Rs,ERd	2					19
DIVXU	DIVXU.B Rs,Rd	1					11
	DIVXU.W Rs,ERd	1					19
EEPMOV	EEPMOV.B	2			$2n+2^{*2}$		
	EEPMOV.W	2			$2n+2^{*2}$		
EXTS	EXTS.W Rd	1					
	EXTS.L ERd	1					
EXTU	EXTU.W Rd	1					
	EXTU.L ERd	1					
INC	INC.B Rd	1					
	INC.W #1/2,Rd	1					
	INC.L #1/2,ERd	1					

Instruction	Mnemonic	Instruction	Branch	Stack	Byte Data	Word	Internal
		Fetch	Address				
		I	J	K	L	M	N
JMP	JMP @ERN	2					
	JMP @aa:24	2					1
	JMP @@aa:8	2	2				1
JSR	JSR @ERn	2		2			
	JSR @aa:24	2		2			1
	JSR @@aa:8	2	2	2			
LCD	LDC #xx:8,CCR	1					
	LDC #xx:8,EXR	2					
	LDC Rs,CCR	1					
	LDC Rs,EXR	1					
	LDC @ERs,CCR	2				1	
	LDC @ERs,EXR	2				1	
	LDC @(d:16,ERs),CCR	3				1	
	LDC @(d:16,ERs),EXR	3				1	
	LDC @(d:32,ERs),CCR	5				1	
	LDC @(d:32,ERs),EXR	5				1	
	LDC @ERs+,CCR	2				1	1
	LDC @ERs+,EXR	2				1	1
	LDC @aa:16,CCR	3				1	
	LDC @aa:16,EXR	3				1	
LDC @aa:32,CCR	4				1		
LDC @aa:32,EXR	4				1		
LDM	LDM.L	2		4			1
	@SP+,(ERn-ERn+1)						
	LDM.L	2		6			1
	@SP+,(ERn-ERn+2)						
LDMAC	LDMAC ERs,MACH	Cannot be used in this LSI.					
	LDMAC ERs,MACL	Cannot be used in this LSI.					
MAC	MAC @ERn+,@ERm+	Cannot be used in this LSI.					

Instruction Mnemonic		Branch	Stack	Word		Internal Operation	
		Instruction Fetch	Address Read	Byte Access	Data Access		Data Access
		I	J	K	L	M	N
MOV	MOV.B #xx:8,Rd	1					
	MOV.B Rs,Rd	1					
	MOV.B @ERs,Rd	1			1		
	MOV.B @(d:16,ERs),Rd	2			1		
	MOV.B @(d:32,ERs),Rd	4			1		
	MOV.B @ERs+,Rd	1			1		1
	MOV.B @aa:8,Rd	1			1		
	MOV.B @aa:16,Rd	2			1		
	MOV.B @aa:32,Rd	3			1		
	MOV.B Rs,@ERd	1			1		
	MOV.B Rs,@(d:16,ERd)	2			1		
	MOV.B Rs,@(d:32,ERd)	4			1		
	MOV.B Rs,@-ERd	1			1		1
	MOV.B Rs,@aa:8	1			1		
	MOV.B Rs,@aa:16	2			1		
	MOV.B Rs,@aa:32	3			1		
	MOV.W #xx:16,Rd	2					
	MOV.W Rs,Rd	1					
	MOV.W @ERs,Rd	1				1	
	MOV.W @(d:16,ERs),Rd	2				1	
	MOV.W @(d:32,ERs),Rd	4				1	
	MOV.W @ERs+,Rd	1				1	1
	MOV.W @aa:16,Rd	2				1	
	MOV.W @aa:32,Rd	3				1	
	MOV.W Rs,@ERd	1				1	
	MOV.W Rs,@(d:16,ERd)	2				1	
	MOV.W Rs,@(d:32,ERd)	4				1	
	MOV.W Rs,@-ERd	1				1	1
	MOV.W Rs,@aa:16	2				1	
	MOV.W Rs,@aa:32	3				1	
	MOV.L #xx:32,ERd	3					
	MOV.L ERs,ERd	1					
	MOV.L @ERs,ERd	2				2	
	MOV.L @(d:16,ERs),ERd	3				2	
	MOV.L @(d:32,ERs),ERd	5				2	
	MOV.L @ERs+,ERd	2				2	1
	MOV.L @aa:16,ERd	3				2	
	MOV.L @aa:32,ERd	4				2	
	MOV.L ERs,@ERd	2				2	
	MOV.L ERs,@(d:16,ERd)	3				2	
	MOV.L ERs,@(d:32,ERd)	5				2	
	MOV.L ERs,@-ERd	2				2	1
	MOV.L ERs,@aa:16	3				2	
	MOV.L ERs,@aa:32	4				2	

Instruction Mnemonic		Instruction Fetch	Branch	Stack Operation	Byte Data	Word Data	Internal Operation	
			Address Read		Access	Access		
		I	J	K	L	M	N	
MOVFP	MOVFP @:aa:16,Rd	Cannot be used in this LSI.						
MOVTPE	MOVTPE Rs,@:aa:16							
MULXS	MULXS.B Rs,Rd	2					11	
	MULXS.W Rs,ERd	2					19	
MULXU	MULXU.B Rs,Rd	1					11	
	MULXU.W Rs,ERd	1					19	
NEG	NEG.B Rd	1						
	NEG.W Rd	1						
	NEG.L ERd	1						
NOP	NOP	1						
NOT	NOT.B Rd	1						
	NOT.W Rd	1						
	NOT.L ERd	1						
OR	OR.B #xx:8,Rd	1						
	OR.B Rs,Rd	1						
	OR.W #xx:16,Rd	2						
	OR.W Rs,Rd	1						
	OR.L #xx:32,ERd	3						
	OR.L ERs,ERd	2						
ORC	ORC #xx:8,CCR	1						
	ORC #xx:8,EXR	2						
POP	POP.W Rn	1				1	1	
	POP.L ERn	2				2	1	
PUSH	PUSH.W Rn	1				1	1	
	PUSH.L ERn	2				2	1	
ROTL	ROTL.B Rd	1						
	ROTL.B #2,Rd	1						
	ROTL.W Rd	1						
	ROTL.W #2,Rd	1						
	ROTL.L ERd	1						
	ROTL.L #2,ERd	1						
ROTR	ROTR.B Rd	1						
	ROTR.B #2,Rd	1						
	ROTR.W Rd	1						
	ROTR.W #2,Rd	1						
	ROTR.L ERd	1						
	ROTR.L #2,ERd	1						

Instruction Mnemonic		Instruction Fetch	Branch	Stack Operation	Byte Data Access	Word	Internal Operation
			Address Read			Data Access	
		I	J	K	L	M	N
ROTXL	ROTXL.B Rd	1					
	ROTXL.B #2,Rd	1					
	ROTXL.W Rd	1					
	ROTXL.W #2,Rd	1					
	ROTXL.L ERd	1					
	ROTXL.L #2,ERd	1					
ROTXR	ROTXR.B Rd	1					
	RPTXR.B #2,Rd	1					
	ROTXR.W Rd	1					
	ROTXR.W #2,Rd	1					
	ROTXR.L ERd	1					
	ROTXR.L #2,ERd	1					
RTE	RTE	2		2/3 <sup>*1</sup>			1
RTS	RTS	2		2			1
SHAL	SHAL.B Rd	1					
	SHAL.B #2,Rd	1					
	SHAL.W Rd	1					
	SHAL.W #2,Rd	1					
	SHAL.L ERd	1					
	SHAL.L #2,ERd	1					
SHAR	SHAR.B Rd	1					
	SHAR.B #2,Rd	1					
	SHAR.W Rd	1					
	SHAR.W #2,Rd	1					
	SHAR.L ERd	1					
	SHAR.L #2,ERd	1					
SHLL	SHLL.B Rd	1					
	SHLL.B #2,Rd	1					
	SHLL.W Rd	1					
	SHLL.W #2,Rd	1					
	SHLL.L ERd	1					
	SHLL.L #2,ERd	1					
SHLR	SHLR.B Rd	1					
	SHLR.B #2,Rd	1					
	SHLR.W Rd	1					
	SHLR.W #2,Rd	1					
	SHLR.L ERd	1					
	SHLR.L #2,ERd	1					
SLEEP	SLEEP	1					1

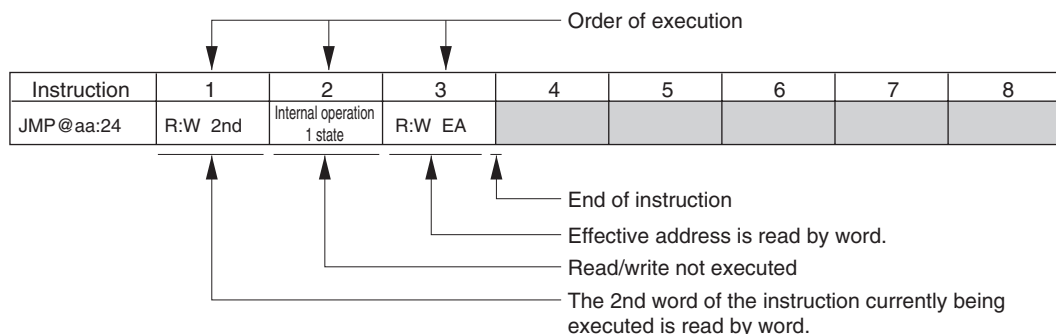
Instruction Mnemonic		Branch			Word		Internal Operation
		Instruction Fetch	Address Read	Stack Operation	Byte Data Access	Data Access	
		I	J	K	L	M	N
STC	STC.B CCR,Rd	1					
	STC.B EXR,Rd	1					
	STC.W CCR,@ERd	2				1	
	STC.W EXR,@ERd	2				1	
	STC.W CCR,@(d:16,ERd)	3				1	
	STC.W EXR,@(d:16,ERd)	3				1	
	STC.W CCR,@(d:32,ERd)	5				1	
	STC.W EXR,@(d:32,ERd)	5				1	
	STC.W CCR,@-ERd	2				1	1
	STC.W EXR,@-ERd	2				1	1
	STC.W CCR,@aa:16	3				1	
	STC.W EXR,@aa:16	3				1	
	STC.W CCR,@aa:32	4				1	
STC.W EXR,@aa:32	4				1		
STM	STM.L (ERn-ERn+1), @-Sp	2		4			1
	STM.L (ERn-ERn+2), @-Sp	2		6			1
	STM.L (ERn-ERn+3), @-Sp	2		8			1
STMAC	STMAC MACH,ERd	Cannot be used in this LSI.					
	STMAC MACL,ERd						
SUB	SUB.B Rs,Rd	1					
	SUB.W #xx:16,Rd	2					
	SUB.W Rs,Rd	1					
	SUB.L #xx:32,ERd	3					
	SUB.L ERs,ERd	1					
SUBS	SUBS #1/2/4,ERd	1					
SUBX	SUBX #xx:8,Rd	1					
	SUBX Rs,Rd	1					
TAS	TAS @ERd <sup>*3</sup>	2			2		
TRAPA	TRAPA #x:2	2	2	2/3 <sup>*1</sup>			2
XOR	XOR.B #xx:8,Rd	1					
	XOR.B Rs,Rd	1					
	XOR.W #xx:16,Rd	2					
	XOR.W Rs,Rd	1					
	XOR.L #xx:32,ERd	3					
	XOR.L ERs,ERd	2					
XORC	XORC #xx:8,CCR	1					
	XORC #xx:8,EXR	2					

- Notes: 1. 3 applies when EXR is valid, and 2 applies when invalid.  
2. Applies when the transfer data is n bytes.  
3. Only register ER0, ER1, ER4, or ER5 should be used when using the TAS instruction.

## A.5 Bus Status during Instruction Execution

Table A.6 indicates execution status of each instruction available in this LSI. For the number of states required for each execution status, see table A.4, Number of States Required for Each Execution Status (Cycle).

[How to see the table]



Legend:

R:B	Read by byte
R:W	Read by word
W:B	Write by byte
W:W	Write by word
:M	Bus not transferred immediately after this cycle
2nd	Address of the 2nd word (3rd and 4th bytes)
3rd	Address of the 3rd word (5th and 6th bytes)
4th	Address of the 4th word (7th and 8th bytes)
5th	Address of the 5th word (9th and 10th bytes)
NEXT	The head address of the instruction immediately after the instruction currently being executed
EA	Execution address
VEC	Vector address

Table A.6 Instruction Execution Status

Instruction	1	2	3	4	5	6	7	8	9
ADD.B #xx:8,Rd	R:W NEXT								
ADD.B Rs,Rd	R:W NEXT								
ADD.W #xx:16,Rd	R:W 2nd	R:W NEXT							
ADD.W Rs,Rd	R:W NEXT								
ADD.L #xx:32,ERd	R:W 2nd	R:W 3rd	R:W NEXT						
ADD.L ERs,ERd	R:W NEXT								
ADDS #1/2/4,ERd	R:W NEXT								
ADDX #xx:8,Rd	R:W NEXT								
ADDX Rs,Rd	R:W NEXT								
AND.B #xx:8,Rd	R:W NEXT								
AND.B Rs,Rd	R:W NEXT								
AND.W #xx:16,Rd	R:W 2nd	R:W NEXT							
AND.W Rs,Rd	R:W NEXT								
AND.L #xx:32,ERd	R:W 2nd	R:W 3rd	R:W NEXT						
AND.L ERs,ERd	R:W 2nd	R:W NEXT							
ANDC #xx:8,CCR	R:W NEXT								
ANDC #xx:8,EXR	R:W 2nd	R:W NEXT							
BAND #xx:3,Rd	R:W NEXT								
BAND #xx:3,@ERd	R:W 2nd	R:B EA	R:W:M NEXT						
BAND #xx:3,@aa:8	R:W 2nd	R:B EA	R:W:M NEXT						
BAND #xx:3,@aa:16	R:W 2nd	R:W 3rd	R:B EA	R:W:M NEXT					
BAND #xx:3,@aa:32	R:W 2nd	R:W 3rd	R:W 4th						
BRA d:8 (BT d:8)	R:W NEXT	R:W EA							
BRN d:8 (BT d:8)	R:W NEXT	R:W EA							
BHI d:8	R:W NEXT	R:W EA							
BLS d:8	R:W NEXT	R:W EA							
BCC d:8 (BHS d:8)	R:W NEXT	R:W EA							
BCS d:8 (BLO d:8)	R:W NEXT	R:W EA							
BNE d:8	R:W NEXT	R:W EA							
BEQ d:8	R:W NEXT	R:W EA							
BVC d:8	R:W NEXT	R:W EA							
BVS d:8	R:W NEXT	R:W EA							
BPL d:8	R:W NEXT	R:W EA							
BMI d:8	R:W NEXT	R:W EA							
BGE d:8	R:W NEXT	R:W EA							
BLT d:8	R:W NEXT	R:W EA							
BGT d:8	R:W NEXT	R:W EA							
BLE d:8	R:W NEXT	R:W EA							
BRA d:16 (BT d:16)	R:W 2nd	Internal operation 1 state	R:W EA						



Instruction	1	2	3	4	5	6	7	8	9
BRN d:16 (BF d:16)	R:W 2nd	Internal operation 1 state	R:W EA						
BHI d:16	R:W 2nd	Internal operation 1 state	R:W EA						
BLS d:16	R:W 2nd	Internal operation 1 state	R:W EA						
BCC d:16 (BHS d:16)	R:W 2nd	Internal operation 1 state	R:W EA						
BCS d:16 (BLO d:16)	R:W 2nd	Internal operation 1 state	R:W EA						
BNE d:16	R:W 2nd	Internal operation 1 state	R:W EA						
BEQ d:16	R:W 2nd	Internal operation 1 state	R:W EA						
BVC d:16	R:W 2nd	Internal operation 1 state	R:W EA						
BVS d:16	R:W 2nd	Internal operation 1 state	R:W EA						
BPL d:16	R:W 2nd	Internal operation 1 state	R:W EA						
BMI d:16	R:W 2nd	Internal operation 1 state	R:W EA						
BGE d:16	R:W 2nd	Internal operation 1 state	R:W EA						
BLT d:16	R:W 2nd	Internal operation 1 state	R:W EA						
BGT d:16	R:W 2nd	Internal operation 1 state	R:W EA						
BLE d:16	R:W 2nd	Internal operation 1 state	R:W EA						
BCLR #xx:3,Rd	R:W NEXT								
BCLR #xx:3,@ERd	R:W 2nd	R:B:M EA	R:W:M NEXT	W:B EA					
BCLR #xx:3,@aa:8	R:W 2nd	R:B:M EA	R:W:M NEXT	W:B EA					
BCLR #xx:3,@aa:16	R:W 2nd	R:W 3rd	R:B:M EA	R:W:M NEXT	W:B EA				

# Appendix A Instruction Set

Instruction	1	2	3	4	5	6	7	8	9
BCLR #xx:3,@aa:32	R:W 2nd	R:W 3rd	R:W 4th	R:B:M EA	R:W:M NEXT	W:B EA			
BCLR Rn,Rd	R:W NEXT								
BCLR Rn,@ERd	R:W 2nd	R:B:M EA	R:W:M NEXT	W:B EA					
BCLR Rn,@aa:8	R:W 2nd	R:B:M EA	R:W:M NEXT	W:B EA					
BCLR Rn,@aa:16	R:W 2nd	R:W 3rd	R:B:M EA	R:W:M NEXT	W:B EA				
BCLR Rn,@aa:32	R:W 2nd	R:W 3rd	R:W 4th	R:B:M EA	R:W:M NEXT	W:B EA			
BIAND #xx:3,Rd	R:W NEXT								
BIAND #xx:3,ERd	R:W 2nd	R:B EA	R:W:M NEXT						
BIAND #xx:3,@aa:8	R:W 2nd	R:B EA	R:W:M NEXT						
BIAND #xx:3,@aa:16	R:W 2nd	R:W 3rd	R:B EA	R:W:M NEXT					
BIAND #xx:3,@aa:32	R:W 2nd	R:W 3rd	R:W 4th	R:B EA	R:W:M NEXT				
BILD #xx:3,Rd	R:W NEXT								
BILD #xx:3,@ERd	R:W 2nd	R:B EA	R:W:M NEXT						
BILD #xx:3,@aa:8	R:W 2nd	R:B EA	R:W:M NEXT						
BILD #xx:3,@aa:16	R:W 2nd	R:W 3rd	R:B EA	R:W:M NEXT					
BILD #xx:3,@aa:32	R:W 2nd	R:W 3rd	R:W 4th	R:B EA	R:W:M NEXT				
BIOR #xx:3,Rd	R:W NEXT								
BIOR #xx:3,@ERd	R:W 2nd	R:B EA	R:W:M NEXT						
BOIR #xx:3,@aa:8	R:W 2nd	R:B EA	R:W:M NEXT						
BOIR #xx:3,@aa:16	R:W 2nd	R:W 3rd	R:B EA	R:W:M NEXT					
BOIR #xx:3,@aa:32	R:W 2nd	R:W 3rd	R:W 4th	R:B EA	R:W:M NEXT				
BIST #xx:3,Rd	R:W NEXT								
BIST #xx:3,@ERd	R:W 2nd	R:B:M EA	R:W:M NEXT	W:B EA					
BIST #xx:3,@aa:8	R:W 2nd	R:B:M EA	R:W:M NEXT	W:B EA					
BIST #xx:3,@aa:16	R:W 2nd	R:W 3rd	R:B:M EA	R:W:M NEXT	W:B EA				
BIST #xx:3,@aa:32	R:W 2nd	R:W 3rd	R:W 4th	R:B:M EA	R:W:M NEXT	W:B EA			

Instruction	1	2	3	4	5	6	7	8	9
BIXOR #xx:3,Rd	R:W NEXT								
BIXOR #xx:3,@ERd	R:W 2nd	R:B EA	R:W:M NEXT						
BIXOR #xx:3,@aa:8	R:W 2nd	R:B EA	R:W:M NEXT						
BIXOR #xx:3,@aa:16	R:W 2nd	R:W 3rd	R:B EA	R:W:M NEXT					
BIXOR #xx:3,@aa:32	R:W 2nd	R:W 3rd	R:W 4th	R:B EA	R:W:M NEXT				
BLD #xx:3,Rd	R:W NEXT								
BLD #xx:3,@ERd	R:W 2nd	R:B EA	R:W:M NEXT						
BLD #xx:3,@aa:8	R:W 2nd	R:B EA	R:W:M NEXT						
BLD #xx:3,@aa:16	R:W 2nd	R:W 3rd	R:B EA	R:W:M NEXT					
BLD #xx:3,@aa:32	R:W 2nd	R:W 3rd	R:W 4th	R:B EA	R:W:M NEXT				
BNOT #xx:3,Rd	R:W NEXT								
BNOT #xx:3,ERd	R:W 2nd	R:B:M EA	R:W:M NEXT	W:B EA					
BNOT #xx:3,@aa:8	R:W 2nd	R:B:M EA	R:W:M NEXT	W:B EA					
BNOT #xx:3,@aa:16	R:W 2nd	R:W 3rd	R:B:M EA	R:W:M NEXT	W:B EA				
BNOT #xx:3,@aa:32	R:W 2nd	R:W 3rd	R:W 4th	R:B:M EA	R:W:M NEXT	W:B EA			
BNOT Rn,Rd	R:W NEXT								
BNOT Rn,@ERd	R:W 2nd	R:B:M EA	R:W:M NEXT	W:B EA					
BNOT Rn @aa:8	R:W 2nd	R:B:M EA	R:W:M NEXT	W:B EA					
BNOT Rn @aa:16	R:W 2nd	R:W 3rd	R:B:W EA	R:W:M NEXT	W:B EA				
BNOT Rn @aa:32	R:W 2nd	R:W 3rd	R:W 4th	R:B:M EA	R:W:M NEXT	W:B EA			
BOR #xx:3,Rd	R:W NEXT								
BOR #xx:3,ERd	R:W 2nd	R:B EA	R:W:M NEXT						
BOR #xx:3,@aa:8	R:W 2nd	R:B EA	R:W:M NEXT						
BOR #xx:3,@aa:16	R:W 2nd	R:W 3rd	R:B EA	R:W:M NEXT					
BOR #xx:3,@aa:32	R:W 2nd	R:W 3rd	R:W 4th	R:B EA	R:W NEXT				

## Appendix A Instruction Set

Instruction	1	2	3	4	5	6	7	8	9
BSET #xx:3,Rd	R:W NEXT								
BSET #xx:3,@ERd	R:W 2nd	R:B:M EA	R:W:M NEXT	W:B EA					
BSET #xx:3,@aa:8	R:W 2nd	R:B:M EA	R:W:M NEXT	W:B EA					
BSET #xx:3,@aa:16	R:W 2nd	R:W 3rd	R:B:M EA	R:W:M NEXT	W:B EA				
BSET #xx:3,@aa:32	R:W 2nd	R:W 3rd	R:W 4th	R:B:M EA	R:W:M NEXT	W:B EA			
BSET Rn,Rd	R:W NEXT								
BSET Rn,@ERd	R:W 2nd	R:B:M EA	R:W:M NEXT	W:B EA					
BSET Rn,@aa:8	R:W 2nd	R:B:M EA	R:W:M NEXT	W:B EA					
BSET Rn,@aa:16	R:W 2nd	R:W 3rd	R:B:M EA	R:W:M NEXT	W:B EA				
BSET Rn,@aa:32	R:W 2nd	R:W 3rd	R:W 4th	R:B:M EA	R:W:M NEXT	W:B EA			
BSR d:8	R:W NEXT	R:W EA	W:W:M stack(H)	W:W stack(L)					
BSR d:16	R:W 2nd	Internal operation 1 state	R:W EA	W:W:M stack(H)	W:W stack(L)				
BST #xx:3,Rd	R:W NEXT								
BST #xx:3,@ERd	R:W 2nd	R:B:M EA	R:W:M NEXT	W:B EA					
BST #xx:3,@aa:8	R:W 2nd	R:B:M EA	R:W:M NEXT	W:B EA					
BST #xx:3,@aa:16	R:W 2nd	R:W 3rd	R:B:M EA	R:W:M NEXT	W:B EA				
BST #xx:3,@aa:32	R:W 2nd	R:W 3rd	R:W 4th	R:B:M EA	R:W:M NEXT	W:B EA			
BTST #xx:3,Rd	R:W NEXT								
BTST #xx:3,@ERd	R:W 2nd	R:B EA	R:W:M NEXT						
BTST #xx:3,@aa:8	R:W 2nd	R:B EA	R:W:M NEXT						
BTST #xx:3,@aa:16	R:W 2nd	R:W 3rd	R:B EA	R:W:M NEXT					
BTST #xx:3,@aa:32	R:W 2nd	R:W 3rd	R:W 4th	R:B EA	R:W:M NEXT				
BTST Rn,Rd	R:W NEXT								
BTST Rn,@ERd	R:W 2nd	R:B EA	R:W:M NEXT						

Instruction	1	2	3	4	5	6	7	8	9
BTST Rn,@aa:8	R:W 2nd	R:B EA	R:W:M NEXT						
BTST Rn,@aa:16	R:W 2nd	R:W 3rd	R:B EA	R:W:M NEXT					
BTST Rn,@aa:32	R:W 2nd	R:W 3rd	R:W 4th	R:B EA	R:W:M NEXT				
BOXR #xx:3,Rd	R:W NEXT								
BOXR #xx:3,@ERd	R:W 2nd	R:B EA	R:W:M NEXT						
BOXR #xx:3,@aa:8	R:W 2nd	R:B EA	R:W:M NEXT						
BOXR #xx:3,@aa:16	R:W 2nd	R:W 3rd	R:B EA	R:W:M NEXT					
BOXR #xx:3,@aa:32	R:W 2nd	R:W 3rd	R:W 4th	R:B EA	R:W:M NEXT				
CLRMAC	Cannot be used in this LSI.								
CMP.B #xx:8,Rd	R:W NEXT								
CMP.B Rs,Rd	R:W NEXT								
CMP.W #xx:16,Rd	R:W 2nd	R:W NEXT							
CMP.W Rs,Rd	R:W NEXT								
CMP.L #xx:32,ERd	R:W 2nd	R:W 3rd	R:W NEXT						
CMP.L ERs,ERd	R:W NEXT								
DAA Rd	R:W NEXT								
DAS Rd	R:W NEXT								
DEC.B Rd	R:W NEXT								
DEC.W #1/2,Rd	R:W NEXT								
DEC.W #1/2,ERd	R:W NEXT								
DIVXS.B Rs,Rd	R:W 2nd	R:W NEXT	Internal operation 11 state						
DIVXS.W Rs,ERd	R:W 2nd	R:W NEXT	Internal operation 19 state						
DIVXU.B Rs,Rd	R:W NEXT	Internal operation 11 state							
DIVXU.W Rs,ERd	R:W NEXT	Internal operation 19 state							
EEPMOV.B	R:W 2nd	R:B EAs <sup>*1</sup>	R:B EAd <sup>*1</sup>	R:B EAs <sup>*2</sup>	W:B Ead <sup>*2</sup>	R:W NEXT			

# Appendix A Instruction Set

Instruction	1	2	3	4	5	6	7	8	9
EEPMOV.W	R:W 2nd	R:B EAs <sup>*1</sup>	R:B EAd <sup>*1</sup>	R:B EAs <sup>*2</sup>	W:B Ead <sup>*2</sup>	R:W NEXT			
EXTS.W Rd	R:W NEXT			← Repeat n times <sup>*2</sup> →					
EXTS.L ERd	R:W NEXT								
EXTU.W Rd	R:W NEXT								
EXTU.L ERd	R:W NEXT								
INC.B Rd	R:W NEXT								
INC.W #1/2,Rd	R:W NEXT								
INC.L #1/2,ERd	R:W NEXT								
JMP @ERn	R:W NEXT	R:W EA							
JMP @aa:24	R:W 2nd	Internal operation 1 state	R:W EA						
JMP @@aa:8	R:W NEXT	R:W:M aa:8	R:W:M aa:8	Internal operation 1 state	R:W EA				
JSR @ERn	R:W NEXT	R:W EA	W:W:M stack(H)	W:W stack (L)					
JSR @aa:24	R:W 2nd	Internal operation 1 state	R:W EA	W:W:M stack(H)	W:W stack (L)				
JSR @@aa:8	R:W NEXT	R:W:M aa:8	R:W aa:8	W:W:M stack(H)	W:W stack (L)	R:W EA			
LCD #xx.8,CCR	R:W NEXT								
LCD #xx.8,EXR	R:W 2nd	R:W NEXT							
LCD Rs,CCR	R:W NEXT								
LCD Rs,EXR	R:W NEXT								
LCD @ERs,CCR	R:W 2nd	R:W NEXT	R:W EA						
LCD @ERs,EXR	R:W 2nd	R:W NEXT	R:W EA						
LCD @(d:16,ERs),CCR	R:W 2nd	R:W 3rd	R:W NEXT	R:W EA					
LCD @(d:16,ERs),EXR	R:W 2nd	R:W 3rd	R:W NEXT	R:W EA					
LCD @(d:32,ERs),CCR	R:W 2nd	R:W 3rd	R:W 4th	R:W 5th	R:W NEXT	R:W EA			
LCD @(d:32,ERs),EXR	R:W 2nd	R:W 3rd	R:W 4th	R:W 5th	R:W NEXT	R:W EA			

Instruction	1	2	3	4	5	6	7	8	9
LCD @ERs+,CCR	R:W 2nd	R:W NEXT	Internal operation 1 state	R:W EA					
LCD @ERs+,EXR	R:W 2nd	R:W NEXT	Internal operation 1 state	R:W EA					
LCD @aa:16,CCR	R:W 2nd	R:W 3rd	R:W NEXT	R:W EA					
LCD @aa:16,EXR	R:W 2nd	R:W 3rd	R:W NEXT	R:W EA					
LCD @aa:32,CCR	R:W 2nd	R:W 3rd	R:W 4th	R:W NEXT	R:W EA				
LCD @aa:32,EXR	R:W 2nd	R:W 3rd	R:W 4th	R:W NEXT	R:W EA				
LDM.L @SP+, (ERn-ERn+1)	R:W 2nd	R:W:M NEXT	Internal operation 1 state	R:W:M stack(H) <sup>*3</sup>	R:W stack(L) <sup>*3</sup>				
LDM.L @SP+, (ERn-ERn+2)	R:W 2nd	R:W:M NEXT	Internal operation 1 state	R:W:M stack(H) <sup>*3</sup>	R:W stack(L) <sup>*3</sup>				
LDM.L @SP+, (ERn-ERn+3)	R:W 2nd	R:W:M NEXT	Internal operation 1 state	R:W:M stack(H) <sup>*3</sup>	R:W stack(L) <sup>*3</sup>				
LDMAC ERs,MACH	Cannot be used in this LSI.								
LDMAC ERs,MACL									
MAC @ERn+,@ERm+									
MOV.B #xx:8,Rd	R:W NEXT								
MOV.B Rs,Rd	R:W NEXT								
MOV.B @ERs,Rd	R:W NEXT	R:B EA							
MOV.B @(d:16,ERs),Rd	R:W 2nd	R:W NEXT	R:B EA						
MOV.B @(d:32,ERs),Rd	R:W 2nd	R:W 3rd	R:W 4th	R:W NEXT	R:B EA				
MOV.B @ERs+,Rd	R:W NEXT	Internal operation 1 state	R:B EA						
MOV.B @aa:8,Rd	R:W NEXT	R:B EA							
MOV.B @aa:16,Rd	R:W 2nd	R:W NEXT	R:B EA						
MOV.B @aa:32,Rd	R:W 2nd	R:W 3rd	R:W NEXT	R:B EA					
MOV.B Rs,@ERd	R:W NEXT	W:B EA							
MOV.B Rs,@(d:16,ERd)	R:W 2nd	R:W NEXT	W:B EA						
MOV.B Rs,@(d:32,ERd)	R:W 2nd	R:W 3rd	R:W 4th	R:W NEXT	W:B EA				

# Appendix A Instruction Set

Instruction	1	2	3	4	5	6	7	8	9
MOV.B Rs,@-ERd	R:W NEXT	Internal operation 1 state	W:B EA						
MOV.B Rs,@aa:8	R:W NEXT	W:B EA							
MOV.B Rs,@aa:16	R:W 2nd	R:W NEXT	W:B EA						
MOV.B Rs,@aa:32	R:W 2nd	R:W 3rd	R:W NEXT	W:B EA					
MOV.W #xx:16,Rd	R:W 2nd	R:W NEXT							
MOV.W Rs,Rd	R:W NEXT								
MOV.W @ERs,Rd	R:W NEXT	R:W EA							
MOV.W @(d:16,ERs),Rd	R:W 2nd	R:W NEXT	R:W EA						
MOV.W @(d:32,ERs),Rd	R:W 2nd	R:W 3rd	R:W 4th	R:W NEXT	R:W EA				
MOV.W @ERs+,Rd	R:W NEXT	Internal operation 1 state	R:W EA						
MOV.W @aa:16,Rd	R:W 2nd	R:W NEXT	R:W EA						
MOV.W @aa:32,Rd	R:W 2nd	R:W 3rd	R:W NEXT	R:B EA					
MOV.W Rs,@ERd	R:W NEXT	W:W EA							
MOV.W Rs,@(d:16,ERd)	R:W 2nd	R:W NEXT	W:W EA						
MOV.W Rs,@(d:32,ERd)	R:W 2nd	R:W 3rd	R:W 4th	R:W NEXT	W:W EA				
MOV.W Rs,@-ERd	R:W NEXT	Internal operation 1 state	W:W EA						
MOV.W Rs,@aa:16	R:W 2nd	R:W NEXT	W:W EA						
MOV.W Rs,@aa:32	R:W 2nd	R:W 3rd	R:W NEXT	W:W EA					
MOV.L #xx:32,ERd	R:W 2nd	R:W 3rd	R:W NEXT						
MOV.L ERs,ERd	R:W NEXT								
MOV.L @ERs,ERd	R:W 2nd	R:W:M NEXT	R:W:M EA	R:W EA+2					
MOV.L @(d:16,ERs),ERd	R:W 2nd	R:W:M 3rd	R:W NEXT	R:W:M EA	R:W EA+2				
MOV.L @(d:32,ERs),ERd	R:W 2nd	R:W:M 3rd	R:W:M 4th	R:W 5th	R:W NEXT	R:W:M EA	R:W EA+2		
MOV.L @ERs+,ERd	R:W 2nd	R:W:M NEXT	Internal operation 1 state	R:W:M EA	R:W EA+2				



Instruction	1	2	3	4	5	6	7	8	9
MOV.L @aa:16,ERd	R:W 2nd	R:W:M 3rd	R:W NEXT	R:W:M EA	R:W EA+2				
MOV.L @aa:32,ERd	R:W 2nd	R:W:M 3rd	R:W 4th	R:W NEXT	R:W:M EA	R:W EA+2			
MOV.L ERs,@ERd	R:W 2nd	R:W:M NEXT	W:W:M EA	W:W EA+2					
MOV.L ERs,@(d:16,ERd)	R:W 2nd	R:W:M 3rd	R:W NEXT	W:W:M EA	W:W EA+2				
MOV.L ERs,@(d:32,ERd)	R:W 2nd	R:W:W 3rd	R:W:M 4th	R:W 5th	R:W NEXT	W:W:M EA	W:W EA+2		
MOV.L ERs,@-ERd	R:W 2nd	R:W:M NEXT	Internal operation 1 state	W:W:M EA	W:W EA+2				
MOV.L ERs,@aa:16	R:W 2nd	R:W:M 3rd	R:W NEXT	W:W:M EA	W:W EA+2				
MOV.L ERs,@aa:32	R:W 2nd	R:W:M 3rd	R:W 4th	R:W NEXT	W:W:M EA	W:W EA+2			
MOVFPPE @aa:16,Rd	Cannot be used in this LSI.								
MOVTPE Rs,@aa:16									
MULXS.B Rs,Rd	R:W 2nd	R:W NEXT	Internal operation 11 state						
MULXS.W Rs,Rd	R:W 2nd	R:W NEXT	Internal operation 19 state						
MULXU.B Rs,Rd	R:W NEXT	Internal operation 11 state							
MULXU.W Rs,Rd	R:W NEXT	Internal operation 19 state							
NEG.B Rd	R:W NEXT								
NEG.W Rd	R:W NEXT								
NEG.L ERd	R:W NEXT								
NOP	R:W NEXT								
NOT.B Rd	R:W NEXT								
NOT.W Rd	R:W NEXT								
NOT.L ERd	R:W NEXT								
OR.B #xx:8,Rd	R:W NEXT								
OR.B Rs,Rd	R:W NEXT								
OR.W #xx:16,Rd	R:W 2nd	R:W NEXT							
OR.W Rs,Rd	R:W NEXT								
OR.L #xx:32,ERd	R:W 2nd	R:W 3rd	R:W NEXT						

# Appendix A Instruction Set

Instruction	1	2	3	4	5	6	7	8	9
OR.L ERs,ERd	R:W 2nd	R:W NEXT							
ORC #xx:8,CCR	R:W NEXT								
ORC #xx:8,EXR	R:W 2nd	R:W NEXT							
POP.W Rn	R:W NEXT	Internal operation 1 state	R:W EA						
POP.L ERn	R:W 2nd	R:W:M NEXT	Internal operation 1 state	R:W:M EA	R:W EA+2				
PUSH.W Rn	R:W NEXT	Internal operation 1 state	W:W EA						
PUSH.L ERn	R:W 2nd	R:W:M NEXT	Internal operation 1 state	W:W:M EA	W:W EA+2				
ROTL.B Rd	R:W NEXT								
ROTL.B #2,Rd	R:W NEXT								
ROTL.W Rd	R:W NEXT								
ROTL.W #2,Rd	R:W NEXT								
ROTL.L ERd	R:W NEXT								
ROTL.L #2, ERd	R:W NEXT								
ROTR.B Rd	R:W NEXT								
ROTR.B #2,Rd	R:W NEXT								
ROTR.W Rd	R:W NEXT								
ROTR.W #2,Rd	R:W NEXT								
ROTR.L ERd	R:W NEXT								
ROTR.L #2,ERd	R:W NEXT								
ROTXL.B Rd	R:W NEXT								
ROTXL.B #2,Rd	R:W NEXT								
ROTXL.W Rd	R:W NEXT								
ROTXL.W #2,Rd	R:W NEXT								
ROTXL.L ERd	R:W NEXT								

Instruction	1	2	3	4	5	6	7	8	9
ROTXL.L #2,ERd	R:W NEXT								
ROTXR.B Rd	R:W NEXT								
ROTXR.B #2,Rd	R:W NEXT								
ROTXR.W Rd	R:W NEXT								
ROTXR.W #2,Rd	R:W NEXT								
ROTXR.L ERd	R:W NEXT								
ROTXR.L #2,ERd	R:W NEXT								
RTE	R:W NEXT	R:W stack (EXR)	R:W stack(H)	R:W stack(L)	Internal operation 1 state	R:W <sup>84</sup>			
RTS	R:W NEXT	R:W:M stack(H)	R:W stack(L)	Internal operation 1 state	R:W <sup>84</sup>				
SHAL.B Rd	R:W NEXT								
SHAL B #2,Rd	R:W NEXT								
SHAL.W Rd	R:W NEXT								
SHAL.W #2,Rd	R:W NEXT								
SHAL.L ERd	R:W NEXT								
SHAL.L #2,ERd	R:W NEXT								
SHAR.B Rd	R:W NEXT								
SHAR.B #2,Rd	R:W NEXT								
SHAR.W Rd	R:W NEXT								
SHAR.W #2,Rd	R:W NEXT								
SHAR.L ERd	R:W NEXT								
SHAR.L #2,ERd	R:W NEXT								
SHLL.B Rd	R:W NEXT								
SHLL.B #2,Rd	R:W NEXT								
SHLL.W Rd	R:W NEXT								
SHLL.W #2,Rd	R:W NEXT								

# Appendix A Instruction Set

Instruction	1	2	3	4	5	6	7	8	9
SHLL.L ERd	R:W NEXT								
SHLL.L #2,ERd	R:W NEXT								
SHLR.B Rd	R:W NEXT								
SHLR.B #2,Rd	R:W NEXT								
SHLR.W Rd	R:W NEXT								
SHLR.W #2,Rd	R:W NEXT								
SHLR.L ERd	R:W NEXT								
SHLR.L #2,ERd	R:W NEXT								
SLEEP	R:W NEXT	Internal operation: M							
STC CCR,Rd	R:W NEXT								
STC EXR,Rd	R:W NEXT								
STC CCR,@ERd	R:W 2nd	R:W NEXT	W:W EA						
STC EXR,@ERd	R:W 2nd	R:W NEXT	W:W EA						
STC CCR,@(d:16,ERd)	R:W 2nd	R:W 3rd	R:W NEXT	W:W EA					
STC EXR,@(d:16,ERd)	R:W 2nd	R:W 3rd	R:W NEXT	W:W EA					
STC CCR,@(d:32,ERd)	R:W 2nd	R:W 3rd	R:W 4th	R:W 5th	R:W NEXT	W:W EA			
STC EXR,@(d:32,ERd)	R:W 2nd	R:W 3rd	R:W 4th	R:W 5th	R:W NEXT	W:W EA			
STC CCR,@-ERd	R:W 2nd	R:W NEXT	Internal operation 1 state	W:W EA					
STC EXR,@-ERd	R:W 2nd	R:W NEXT	Internal operation 1 state	W:W EA					
STC CCR,@aa:16	R:W 2nd	R:W 3rd	R:W NEXT	W:W EA					
STC EXR,@aa:16	R:W 2nd	R:W 3rd	R:W NEXT	W:W EA					
STC CCR,@aa:32	R:W 2nd	R:W 3rd	R:W 4th	R:W NEXT	W:W EA				
STC EXR,@aa:32	R:W 2nd	R:W 3rd	R:W 4th	R:W NEXT	W:W EA				
STM.L (ERn- ERn+1),@-SP	R:W 2nd	R:W:M NEXT	Internal operation 1 state	W:W:M stack (H) *3	W:W stack (L) *3				

Instruction	1	2	3	4	5	6	7	8	9
STM.L (ERn-ERn+2),@-SP	R:W 2nd	R:W:M NEXT	Internal operation 1 state	W:W:M stack (H) * <sub>3</sub>	W:W stack (L) <sup>*3</sup>				
STM.L (ERn-ERn+3),@-SP	R:W 2nd	R:W:M NEXT	Internal operation 1 state	W:W:M stack (H) * <sub>3</sub>	W:W stack (L) <sup>*3</sup>				
STMAC MACH,ERd	Cannot be used in this LSI.								
STMAC MACL,ERd									
SUB.B Rs,Rd	R:W NEXT								
SUB.W #xx:16,Rd	R:W 2nd	R:W NEXT							
SUB.W Rs,Rd	R:W NEXT								
SUB.L #xx:32,ERd	R:W 2nd	R:W 3rd	R:W NEXT						
SUB.L ERs,ERd	R:W NEXT								
SUB #1/2/4,ERd	R:W NEXT								
SUBX #xx:8,Rd	R:W NEXT								
SUBX Rs,Rd	R:W NEXT								
TAS @ERd <sup>*8</sup>	R:W 2nd	R:W NEXT	R:B:M EA	W:B EA					
TRAPA #x:2	R:W NEXT	Internal operation 1 state	W:W stack(L)	W:W stack(H)	W:W stack (EXR)	R:W:M VEC	R:W VEC+2	Internal operation 1 state	R:W <sup>*7</sup>
XOR.B #xx:8,Rd	R:W NEXT								
XOR.B Rs,Rd	R:W NEXT								
XOR.W #xx:16,Rd	R:W 2nd	R:W NEXT							
XOR.W Rs,Rd	R:W NEXT								
XOR.L #xx:32,ERd	R:W 2nd	R:W 3rd	R:W NEXT						
XOR.L ERs,ERd	R:W 2nd	R:W NEXT							
XORC #xx:8,CCR	R:W NEXT								
XORC #xx:8,EXR	R:W 2nd	R:W NEXT							

Instruction	1	2	3	4	5	6	7	8	9
Reset exception handling	R:W:M VEC	R:W VEC+2	Internal operation 1 state	R:W <sup>*5</sup>					
Interrupt exception handling	R:W <sup>*6</sup>	Internal operation 1 state	W:W stack(L)	W:W stack(H)	W:W stack (EXR)	R:W:M VEC	R:W VEC+2	Internal operation 1 state	R:W <sup>*7</sup>

- Notes:
1. EAs is the contents of ER5, and EAd is the contents of ER6.
  2. 1 is added to EAs and EAd after execution. n is the initial value of R4L or R4. When 0 is set to n, R4L or R4 is not executed.
  3. Repeated twice for 2-unit retract/return, three times for 3-unit retract/return, and four times for 4-retract/return.
  4. Head address after return.
  5. Start address of the program.
  6. Pre-fetch address obtained by adding 2 to the PC to be retracted.  
When returning from sleep mode, standby mode or watch mode, internal operation is executed instead of read operation.
  7. Head address of the interrupt process routine.
  8. Only register ER0, ER1, ER4, or ER5 should be used when using the TAS instruction.

## A.6 Change of Condition Codes

This section explains change of condition codes after instruction execution of the CPU. Legend of the following tables is as follows.

m = 31: Longword size

m = 15: Word size

m = 7: Byte size

Si: Bit i of source operand

Di: Bit i of destination operand

Ri: Bit i of result

Dn: Specified bit of destination operand

—: No affection

↑: Changes depending on execution result

0: Always cleared to 0

1: Always set to 1

\*: Value undetermined

Z': Z flag before execution

C': C flag before execution

Table A.7 Change of Condition Code

Instruction	H	N	Z	V	C	Definition
ADD	↕	↕	↕	↕	↕	$H = S_m \cdot 4 \cdot D_m \cdot 4 + D_m \cdot 4 \cdot \overline{R_m} \cdot 4 + S_m \cdot 4 \cdot \overline{R_m} \cdot 4$ $N = R_m$ $Z = \overline{R_m} \cdot R_m \cdot \overline{1} \cdot \dots \cdot \overline{R_0}$ $V = S_m \cdot D_m \cdot \overline{R_m} + S_m \cdot \overline{D_m} \cdot R_m$ $C = S_m \cdot D_m + D_m \cdot \overline{R_m} + S_m \cdot \overline{R_m}$
ADDS	—	—	—	—	—	
ADDX	↕	↕	↕	↕	↕	$H = S_m \cdot 4 \cdot D_m \cdot 4 + D_m \cdot 4 \cdot \overline{R_m} \cdot 4 + S_m \cdot 4 \cdot \overline{R_m} \cdot 4$ $N = R_m$ $Z = Z' \cdot R_m \cdot \dots \cdot \overline{R_0}$ $V = S_m \cdot D_m \cdot \overline{R_m} + S_m \cdot \overline{D_m} \cdot R_m$ $C = S_m \cdot D_m + D_m \cdot \overline{R_m} + S_m \cdot \overline{R_m}$
AND	—	↕	↕	0	—	$N = R_m$ $Z = \overline{R_m} \cdot \overline{R_m} \cdot \overline{1} \cdot \dots \cdot \overline{R_0}$
ANDC	↕	↕	↕	↕	↕	Value in the bit corresponding to execution result is stored. No flag change when EXR.
BAND	—	—	—	—	↕	$C = C' \cdot D_n$
Bcc	—	—	—	—	—	
BCLR	—	—	—	—	—	
BIAND	—	—	—	—	↕	$C = C' \cdot \overline{D_n}$
BILD	—	—	—	—	↕	$C = \overline{D_n}$
BIOR	—	—	—	—	↕	$C = C' + \overline{D_n}$
BIST	—	—	—	—	—	
BIXOR	—	—	—	—	↕	$C = C' \cdot D_n + C' \cdot \overline{D_n}$
BLD	—	—	—	—	↕	$C = D_n$
BNOT	—	—	—	—	—	
BOR	—	—	—	—	↕	$C = C' + D_n$
BSET	—	—	—	—	—	
BSR	—	—	—	—	—	
BST	—	—	—	—	—	
BTST	—	—	↕	—	—	$Z = \overline{D_n}$
BXOR	—	—	—	—	↕	$C = C' \cdot \overline{D_n} + C' \cdot D_n$
CLRMAC	Cannot be used in this LSI.					



Instruction	H	N	Z	V	C	Definition
CMP	↓	↓	↓	↓	↓	$H = \overline{Sm-4} \cdot \overline{Dm-4} + \overline{Dm-4} \cdot Rm-4 + Sm-4 \cdot Rm-4$ $N = Rm$ $Z = \overline{Rm} \cdot \overline{Rm-1} \cdot \dots \cdot \overline{R0}$ $V = Sm \cdot Dm \cdot \overline{Rm} + \overline{Sm} \cdot Dm \cdot Rm$ $C = Sm \cdot \overline{Dm} + \overline{Dm} \cdot Rm + Sm \cdot Rm$
DAA	*	↓	↓	*	↓	$N = Rm$ $Z = \overline{Rm} \cdot \overline{Rm-1} \cdot \dots \cdot \overline{R0}$ C: Decimal addition carry
DAS	*	↓	↓	*	↓	$N = Rm$ $Z = \overline{Rm} \cdot \overline{Rm-1} \cdot \dots \cdot \overline{R0}$ C: Decimal subtraction borrow
DEC	—	↓	↓	↓	—	$N = Rm$ $Z = \overline{Rm} \cdot \overline{Rm-1} \cdot \dots \cdot \overline{R0}$ $V = Dm \cdot \overline{Rm}$
DIVXS	—	↓	↓	—	—	$N = \overline{Sm} \cdot \overline{Dm} + \overline{Sm} \cdot Dm$ $Z = \overline{Sm} \cdot \overline{Sm-1} \cdot \dots \cdot \overline{S0}$
DIVXU	—	↓	↓	—	—	$N = Sm$ $Z = \overline{Sm} \cdot \overline{Sm-1} \cdot \dots \cdot \overline{S0}$
EPMOV	—	—	—	—	—	
EXTS	—	↓	↓	0	—	$N = Rm$ $Z = \overline{Rm} \cdot \overline{Rm-1} \cdot \dots \cdot \overline{R0}$
EXTU	—	0	↓	0	—	$Z = \overline{Rm} \cdot \overline{Rm-1} \cdot \dots \cdot \overline{R0}$
INC	—	↓	↓	↓	—	$N = Rm$ $Z = \overline{Rm} \cdot \overline{Rm-1} \cdot \dots \cdot \overline{R0}$ $V = Dm \cdot Rm$
JMP	—	—	—	—	—	
JSR	—	—	—	—	—	
LDC	↓	↓	↓	↓	↓	Value in the bit corresponding to execution result is stored. No flag change when EXR.
LDM	—	—	—	—	—	
LDMAC	Cannot be used in this LSI.					
MAC						
MOV	—	↓	↓	0	—	$N = Rm$ $Z = \overline{Rm} \cdot \overline{Rm-1} \cdot \dots \cdot \overline{R0}$

Instruction	H	N	Z	V	C	Definition
MOVFP	—	—	—	—	—	Cannot be used in this LSI.
MOVTP	—	—	—	—	—	
MULXS	—	↓	↓	—	—	$N=R2m$ $Z=\overline{R2m} \cdot \overline{R2m-1} \cdot \dots \cdot \overline{R0}$
MULXU	—	—	—	—	—	
NEG	↓	↓	↓	↓	↓	$H=Dm-4+Rm-4$ $N=Rm$ $Z=\overline{Rm} \cdot \overline{Rm-1} \cdot \dots \cdot \overline{R0}$ $V=Dm \cdot Rm$ $C=Dm+Rm$
NOP	—	—	—	—	—	
NOT	—	↓	↓	0	—	$N=Rm$ $Z=\overline{Rm} \cdot \overline{Rm-1} \cdot \dots \cdot \overline{R0}$
OR	—	↓	↓	0	—	$N=Rm$ $Z=\overline{Rm} \cdot \overline{Rm-1} \cdot \dots \cdot \overline{R0}$
ORC	↓	↓	↓	↓	↓	Value in the bit corresponding to execution result is stored. No flag change when EXR.
POP	—	↓	↓	0	—	$N=Rm$ $Z=\overline{Rm} \cdot \overline{Rm-1} \cdot \dots \cdot \overline{R0}$
PUSH	—	↓	↓	0	—	$N=Rm$ $Z=\overline{Rm} \cdot \overline{Rm-1} \cdot \dots \cdot \overline{R0}$
ROTL	—	↓	↓	0	↓	$N=Rm$ $Z=\overline{Rm} \cdot \overline{Rm-1} \cdot \dots \cdot \overline{R0}$ $C=Dm$ (In case of 1 bit), $C=Dm-1$ (In case of 2 bits)
ROTR	—	↓	↓	0	↓	$N=Rm$ $Z=\overline{Rm} \cdot \overline{Rm-1} \cdot \dots \cdot \overline{R0}$ $C=D0$ (In case of 1 bit), $C=D1$ (In case of 2 bits)
ROTXL	—	↓	↓	0	↓	$N=Rm$ $Z=\overline{Rm} \cdot \overline{Rm-1} \cdot \dots \cdot \overline{R0}$ $C=Dm$ (In case of 1 bit), $C=Dm-1$ (In case of 2 bits)
ROTXR	—	↓	↓	0	↓	$N=Rm$ $Z=\overline{Rm} \cdot \overline{Rm-1} \cdot \dots \cdot \overline{R0}$ $C=D0$ (In case of 1 bit), $C=D1$ (In case of 2 bits)
RTE	↓	↓	↓	↓	↓	Value in the bit corresponding to execution result is stored.
RTS	—	—	—	—	—	

Instruction	H	N	Z	V	C	Definition
SHAL	—	↓	↓	↓	↓	$N=Rm$ $Z=\overline{Rm} \cdot \overline{Rm-1} \cdot \dots \cdot \overline{R0}$ $V = \overline{Dm} \cdot Dm-1 + Dm \cdot \overline{Dm-1}$ (In case of 1-bit) $V = \overline{Dm} \cdot Dm-1 \cdot \overline{Dm-2} \cdot Dm \cdot \overline{Dm-1} \cdot \overline{Dm-2}$ (In case of 2-bit) $C=Dm$ (In case of 1 bit), $C=Dm-1$ (In case of 2 bits)
SHAR	—	↓	↓	0	↓	$N=Rm$ $Z=\overline{Rm} \cdot \overline{Rm-1} \cdot \dots \cdot \overline{R0}$ $C=D0$ (In case of 1 bit), $C=D1$ (In case of 2 bits)
SHLL	—	↓	↓	0	↓	$N=Rm$ $Z=\overline{Rm} \cdot \overline{Rm-1} \cdot \dots \cdot \overline{R0}$ $C=Dm$ (In case of 1 bit), $C=Dm-1$ (In case of 2 bits)
SHLR	—	0	↓	0	↓	$N=Rm$ $Z=\overline{Rm} \cdot \overline{Rm-1} \cdot \dots \cdot \overline{R0}$ $C=D0$ (In case of 1 bit), $C=D1$ (In case of 2 bits)
SLEEP	—	—	—	—	—	
STC	—	—	—	—	—	
STM	—	—	—	—	—	
STMAC	Cannot be used in this LSI.					
SUB	↓	↓	↓	↓	↓	$H=Sm-4 \cdot \overline{Dm-4} + Dm-4 \cdot Rm-4 + Sm-4 \cdot Rm-4$ $N=Rm$ $Z=\overline{Rm} \cdot \overline{Rm-1} \cdot \dots \cdot \overline{R0}$ $V=\overline{Sm} \cdot Dm \cdot \overline{Rm} + Sm \cdot \overline{Dm} \cdot Rm$ $C=Sm \cdot \overline{Dm} + Dm \cdot Rm + Sm \cdot Rm$
SUBS	—	—	—	—	—	
SUBX	↓	↓	↓	↓	↓	$H=Sm-4 \cdot \overline{Dm-4} + Dm-4 \cdot Rm-4 + Sm-4 \cdot Rm-4$ $N=Rm$ $Z=Z' \cdot \overline{Rm} \cdot \dots \cdot \overline{R0}$ $V=\overline{Sm} \cdot Dm \cdot \overline{Rm} + Sm \cdot \overline{Dm} \cdot Rm$ $C=Sm \cdot \overline{Dm} + Dm \cdot Rm + Sm \cdot Rm$
TAS	—	↓	↓	0	—	$N=Dm$ $Z=\overline{Dm} \cdot \overline{Dm-1} \cdot \dots \cdot \overline{D0}$
TRAPA	—	—	—	—	—	
XOR	—	↓	↓	0	—	$N=Rm$ $Z=\overline{Rm} \cdot \overline{Rm-1} \cdot \dots \cdot \overline{R0}$
XORC	↓	↓	↓	↓	↓	Value in the bit corresponding to execution result is stored. No flag change when EXR.

# Appendix B Internal I/O Registers

## B.1 Addresses

Address*	Register Name	R/W	Access	Bus Width	Bus								Module Name
					7	6	5	4	3	2	1	0	
H'D000	DGKp	W	16	16	DGKp15	DGKp14	DGKp13	DGKp12	DGKp11	DGKp10	DGKp9	DGKp8	Drum digital filter
H'D001					DGKp7	DGKp6	DGKp5	DGKp4	DGKp3	DGKp2	DGKp1	DGKp0	
H'D002	DGKs	W	16	16	DGKs15	DGKs14	DGKs13	DGKs12	DGKs11	DGKs10	DGKs9	DGKs8	
H'D003					DGKs7	DGKs6	DGKs5	DGKs4	DGKs3	DGKs2	DGKs1	DGKs0	
H'D004	DAp	W	16	16	DAp15	DAp14	DAp13	DAp12	DAp11	DAp10	DAp9	DAp8	
H'D005					DAp7	DAp6	DAp5	DAp4	DAp3	DAp2	DAp1	DAp0	
H'D006	DBp	W	16	16	DBp15	DBp14	DBp13	DBp12	DBp11	DBp10	DBp9	DBp8	
H'D007					DBp7	DBp6	DBp5	DBp4	DBp3	DBp2	DBp1	DBp0	
H'D008	DAs	W	16	16	DAs15	DAs14	DAs13	DAs12	DAs11	DAs10	DAs9	DAs8	
H'D009					DAs7	DAs6	DAs5	DAs4	DAs3	DAs2	DAs1	DAs0	
H'D00A	DBs	W	16	16	DBs15	DBs14	DBs13	DBs12	DBs11	DBs10	DBs9	DBs8	
H'D00B					DBs7	DBs6	DBs5	DBs4	DBs3	DBs2	DBs1	DBs0	
H'D00C	DOfp	W	16	16	DOfp15	DOfp14	DOfp13	DOfp12	DOfp11	DOfp10	DOfp9	DOfp8	
H'D00D					DOfp7	DOfp6	DOfp5	DOfp4	DOfp3	DOfp2	DOfp1	DOfp0	
H'D00E	DOfs	W	16	16	DOfs15	DOfs14	DOfs13	DOfs12	DOfs11	DOfs10	DOfs9	DOfs8	
H'D00F					DOfs7	DOfs6	DOfs5	DOfs4	DOfs3	DOfs2	DOfs1	DOfs0	
H'D010	CGKp	W	16	16	CGKp15	CGKp14	CGKp13	CGKp12	CGKp11	CGKp10	CGKp9	CGKp8	Capstan digital filter
H'D011					CGKp7	CGKp6	CGKp5	CGKp4	CGKp3	CGKp2	CGKp1	CGKp0	
H'D012	CGKs	W	16	16	CGKs15	CGKs14	CGKs13	CGKs12	CGKs11	CGKs10	CGKs9	CGKs8	
H'D013					CGKs7	CGKs6	CGKs5	CGKs4	CGKs3	CGKs2	CGKs1	CGKs0	
H'D014	CAp	W	16	16	CAp15	CAp14	CAp13	CAp12	CAp11	CAp10	CAp9	CAp8	
H'D015					CAp7	CAp6	CAp5	CAp4	CAp3	CAp2	CAp1	CAp0	
H'D016	CBp	W	16	16	CBp15	CBp14	CBp13	CBp12	CBp11	CBp10	CBp9	CBp8	
H'D017					CBp7	CBp6	CBp5	CBp4	CBp3	CBp2	CBp1	CBp0	
H'D018	CAs	W	16	16	CAs15	CAs14	CAs13	CAs12	CAs11	CAs10	CAs9	CAs8	
H'D019					CAs7	CAs6	CAs5	CAs4	CAs3	CAs2	CAs1	CAs0	
H'D01A	CBs	W	16	16	CBs15	CBs14	CBs13	CBs12	CBs11	CBs10	CBs9	CBs8	
H'D01B					CBs7	CBs6	CBs5	CBs4	CBs3	CBs2	CBs1	CBs0	
H'D01C	COfp	W	16	16	COfp15	COfp14	COfp13	COfp12	COfp11	COfp10	COfp9	COfp8	
H'D01D					COfp7	COfp6	COfp5	COfp4	COfp3	COfp2	COfp1	COfp0	
H'D01E	COfs	W	16	16	COfs15	COfs14	COfs13	COfs12	COfs11	COfs10	COfs9	COfs8	
H'D01F					COfs7	COfs6	COfs5	COfs4	COfs3	COfs2	COfs1	COfs0	

Address*	Register Name	R/W	Access	Bus Width	Bus								Module Name
					7	6	5	4	3	2	1	0	
H'D020	DZs	W	16	16	—	—	—	—	DZs11	DZs10	DZs9	DZs8	Digital filter
H'D021					DZs7	DZs6	DZs5	DZs4	DZs3	DZs2	DZs1	DZs0	
H'D022	DZp	W	16	16	—	—	—	—	DZp11	DZp10	DZp9	DZp8	
H'D023					DZp7	DZp6	DZp5	DZp4	DZp3	DZp2	DZp1	DZp0	
H'D024	CZs	W	16	16	—	—	—	—	CZs11	CZs10	CZs9	CZs8	
H'D025					CZs7	CZs6	CZs5	CZs4	CZs3	CZs2	CZs1	CZs0	
H'D026	CZp	W	16	16	—	—	—	—	CZp11	CZp10	CZp9	CZp8	
H'D027					CZp7	CZp6	CZp5	CZp4	CZp3	CZp2	CZp1	CZp0	
H'D028	DFIC	R/W	8	16	—	DROV	DPHA	DZPON	DZSON	DSG2	DSG1	DSC0	
H'D029	CFIC	R/W	8		—	CROV	CPHA	CZPON	CZSON	CSG2	CSG1	CSG0	
H'D02A	DFUCR	R/W	8	16	—	—	PTON	CP/DP	CFEPS	DFEPS	CFESS	DFESS	
H'D030	DFPR	W	16	16	DFPR15	DFPR14	DFPR13	DFPR12	DFPR11	DFPR10	DFPR9	DFPR8	
H'D031					DFPR7	DFPR6	DFPR5	DFPR4	DFPR3	DFPR2	DFPR1	DFPR0	
H'D032	DFER	R/W	16	16	DFER15	DFER14	DFER13	DFER12	DFER11	DFER10	DFER9	DFER8	
H'D033					DFER7	DFER6	DFER5	DFER4	DFER3	DFER2	DFER1	DFER0	
H'D034	DFRUDR	W	16	16	DFRUDR15	DFRUDR14	DFRUDR13	DFRUDR12	DFRUDR11	DFRUDR10	DFRUDR9	DFRUDR8	
H'D035					5	4	3	2	1	0			
H'D036	DFRLDR	W	16	16	DFRLDR15	DFRLDR14	DFRLDR13	DFRLDR12	DFRLDR11	DFRLDR10	DFRLDR9	DFRLDR8	
H'D037					5	4	3	2	1	0			
H'D038	DFVCR	R/W	8	16	DFCS1	DFCS0	DFOVF	DFRFON	DF-R/UNR OPCNT	DFRCS1	DFRCS0		
H'D039	DPGCR	R/W	8	16	DPCS1	DPCS0	DPOVF	N/V	HSWES	—	—	—	
H'D03A	DPPR2	W	16	16	DPPR15	DPPR14	DPPR13	DPPR12	DPPR11	DPPR10	DPPR9	DPPR8	
H'D03B					DPPR7	DPPR6	DPPR5	DPPR4	DPPR3	DPPR2	DPPR1	DPPR0	
H'D03C	DPPR1	W	8	16	—	—	—	—	DPPR19	DPPR18	DPPR17	DPPR16	
H'D03D	DPER1	W	8	16	—	—	—	—	DPER19	DPER18	DPER17	DPER16	
H'D03E	DPER2	W	16	16	DPER15	DPER14	DPER13	DPER12	DPER11	DPER10	DPER9	DPER8	
H'D03F					DPER7	DPER6	DPER5	DPER4	DPER3	DPER2	DPER1	DPER0	
H'D050	CFPR	W	16	16	CFPR15	CFPR14	CFPR13	CFPR12	CFPR11	CFPR10	CFPR9	CFPR8	Capstan error detector
H'D051					CFPR7	CFPR6	CFPR5	CFPR4	CFPR3	CFPR2	CFPR1	CFPR0	
H'D052	CFER	R/W	16	16	CFER15	CFER14	CFER13	CFER12	CFER11	CFER10	CFER9	CFER8	
H'D053					CFER7	CFER6	CFER5	CFER4	CFER3	CFER2	CFER1	CFER0	
H'D054	CFRUDR	W	16	16	CFRUDR15	CFRUDR14	CFRUDR13	CFRUDR12	CFRUDR11	CFRUDR10	CFRUDR9	CFRUDR8	
H'D055					5	4	3	2	1	0			
H'D056	CFRLDR	W	16	16	CFRLDR15	CFRLDR14	CFRLDR13	CFRLDR12	CFRLDR11	CFRLDR10	CFRLDR9	CFRLDR8	
H'D057					5	4	3	2	1	0			
H'D058	CFVCR	R/W	8	16	CFCS1	CFCS0	CFOVF	CFRFON	CF-R/UNR CPCNT	CFRCS1	CFRCS0		
H'D059	CPGCR	R/W	8	16	CPCS1	CPCS0	CPOVF	CR/RF	SELFCFG2	—	—	—	

# Appendix B Internal I/O Registers

Address*	Register Name	R/W	Access	Bus Width	7	6	5	4	3	2	1	0	Module Name
H'D05A	CPPR2	W	16	16	CPH15	CPH14	CPH13	CPH12	CPH11	CPH10	CPH9	CPH8	Capstan error detector
H'D05B					CPH7	CPH6	CPH5	CPH4	CPH3	CPH2	CPH1	CPH0	
H'D05C	CPPR1	W	8	16	—	—	—	—	CPH19	CPH18	CPH17	CPH16	
H'D05D	CPER1	W	8	16	—	—	—	—	CPER19	CPER18	CPER17	CPER16	
H'D05E	CPER2	W	16	16	CPER15	CPER14	CPER13	CPER12	CPER11	CPER10	CPER9	CPER8	
H'D05F					CPER7	CPER6	CPER5	CPER4	CPER3	CPER2	CPER1	CPER0	
H'D060	HSM1	R/W	8	16	FLB	FLA	EMPB	EMPA	OVWB	OVWA	CLRB	CLRA	HSW timing generator * Assign to the same address.
H'D061	HSM2	R/W	8		FRT	FGR2OFF	LOP	EDG	ISEL	SOFG	OFG	VFF/NFF	
H'D062	HSLP	W	8	16	LOB3	LOB2	LOB1	LOB0	LOA3	LOA2	LOA1	LOA0	
H'D064	FPDRA	W	16	16	—	ADTRGA	STRIGA	NarrowFF A	VFFA	AFFA	VpulseA	MlevelA	
H'D065					PPGA7	PPGA6	PPGA5	PPGA4	PPGA3	PPGA2	PPGA1	PPGA0	
H'D066	FTPRA*	W	16	16	FTPRA15	FTRPA14	FTRPA13	FTRPA12	FTRPA11	FTRPA10	FTRPA9	FTRPA8	
H'D066	FTCTR*	R	16		FTCTR15	FTCTR14	FTCTR13	FTCTR12	FTCTR11	FTCTR10	FTCTR9	FTCTR8	
H'D067	FTPRA*	W	16	16	FTPRA7	FTPRA6	FTPRA5	FTPRA4	FTPRA3	FTPRA2	FTPRA1	FTPRA0	
H'D067	FTCTR*	R	16		FTCTR7	FTCTR6	FTCTR5	FTCTR4	FTCTR3	FTCTR2	FTCTR1	FTCTR0	
H'D068	FPDRB	W	16	16	—	ADTRGB	STRIGB	NarrowFF B	VFFB	AFFB	VpulseB	MlevelB	
H'D069					PPGB7	PPGB6	PPGB5	PPGB4	PPGB3	PPGB2	PPGB1	PPGB0	
H'D06A	FTPRB	W	16	16	FTPRB15	FTPRB14	FTPRB13	FTPRB12	FTPRB11	FTPRB10	FTPRB9	FTPRB8	
H'D06B					FTPRB7	FTPRB6	FTPRB5	FTPRB4	FTPRB3	FTPRB2	FTPRB1	FTPRB0	
H'D06C	DFCTR*	W	8	16	ISEL2	CCLR	CKSL	DFCRA4	DFCRA3	DFCRA2	DFCRA1	DFCRA0	
H'D06C	DFCRB	R	8		—	—	—	DFCTR4	DFCTR3	DFCTR2	DFCTR1	DFCTR0	
H'D06D	DFCRB	W	8	16	—	—	—	DFCRB4	DFCRB3	DFCRB2	DFCRB1	DFCRB0	
H'D06E	CHCR	W	8	16	V/N	HSWPOL	CRH	HAH	SIG3	SIG2	SIG1	SIG0	4-head special-effects playback
H'D06F	ADDVR	R/W	8		—	—	—	HMSK	Hi-Z	CUT	VPON	POL	Additional V
H'D070	XDR	W	16	16	—	—	—	—	XR11	XR10	XR9	XR8	X-value, TRK-value
H'D071					XR7	XR6	XR5	XR4	XR3	XR2	XR1	XR0	
H'D072	TRDR	W	16	16	—	—	—	—	TRD11	TRD10	TRD9	TRD8	
H'D073					TRD7	TRD6	TRD5	TRD4	TRD3	TRD2	TRD1	TRD0	
H'D074	XTCR	R/W	8	16	—	CAPRF	AT/MŪ	TRK/X	EXC/REF	XCS	DVRER1	DVREF0	
H'D078	DPWDR	R/W	16	16	—	—	—	—	DPWDR11	DPWDR10	DPWDR9	DPWDR8	Drum 12-bit PWM
H'D079					DPWDR7	DPWDR6	DPWDR5	DPWDR4	DPWDR3	DPWDR2	DPWDR1	DPWDR0	
H'D07A	DPWCR	W	8	16	DPOL	DDC	DHIZ	DH/L	DSFDF	DCK2	DCK1	DCK0	
H'D07B	CPWCR	W	8		CPOL	CDC	CHIZ	CH/L	CSF/DF	CCK2	CCK1	CCK0	Capstan 12-bit PWM
H'D07C	CPWDR	R/W	16	16	—	—	—	—	CPWDR11	CPWDR10	CPWDR9	CPWDR8	
H'D07D					CPWDR7	CPWDR6	CPWDR5	CPWDR4	CPWDR3	CPWDR2	CPWDR1	CPWDR0	

Address*	Register Name	R/W	Bus										Module Name
			Access	Width	7	6	5	4	3	2	1	0	
H'D080	CTCR	W	8	16	NT/PAL	FLSC	FLSB	FSLA	CCS	LCTL	UNCTL	SLWM	CTL circuit
H'D081	CTLM	R/W	8		ASM	REC/PB	FW/RV	MD4	MD3	MD3	MD1	MD0	
H'D082	RCDR1	W	16	16	—	—	—	—	CMT1B	CMT1A	CMT19	CMT18	
H'D083					CMT17	CMT16	CMT15	CMT14	CMT13	CMT12	CMT11	CMT10	
H'D084	RCDR2	W	16	16	—	—	—	—	CMT2B	CMT2A	CMT29	CMT28	
H'D085					CMT27	CMT26	CMT25	CMT24	CMT23	CMT22	CMT21	CMT20	
H'D086	RCDR3	W	16	16	—	—	—	—	CMT3B	CMT3A	CMT39	CMT38	
H'D087					CMT37	CMT36	CMT35	CMT34	CMT33	CMT32	CMT31	CMT30	
H'D088	RCDR4	W	16	16	—	—	—	—	CMT4B	CMT4A	CMT49	CMT48	
H'D089					CMT47	CMT46	CMT45	CMT44	CMT43	CMT42	CMT41	CMT40	
H'D08A	RCDR5	W	16	16	—	—	—	—	CMT5B	CMT5A	CMT59	CMT58	
H'D08B					CMT57	CMT56	CMT55	CMT54	CMT53	CMT52	CMT51	CMT50	
H'D08C	DI/O	R/W	8	16	VCTR2	VCTR1	VCTR0	—	BPON	BPS	BPF	DI/O	
H'D08D	BTPR	R/W	8		LSP7	LSP6	LSP5	LSP4	LSP3	LSP2	LSP1	LSP0	
H'D090	RFD	W	16	16	REF15	REF14	REF13	REF12	REF11	REF10	REF9	REF8	Reference signal generator
H'D091					REF7	REF6	REF5	REF4	REF3	REF2	REF1	REF0	
H'D092	CRF	W	16	16	CRF15	CRF14	CRF13	CRF12	CRF11	CRF10	CRF9	CRF8	
H'D093					CRF7	CRF6	CRF5	CRF4	CRF3	CRF2	CRF1	CRF0	
H'D094	RFC	R/W	16	16	RFC15	RFC14	RFC13	RFC12	RFC11	RFC10	RFC9	RFC8	*The TBC bit is available only in the H8S/2194 C Group.
H'D095					RFC7	RFC6	RFC5	RFC4	RFC3	RFC2	RFC1	RFC0	
H'D096	RFM	R/W	8	16	RCF	VNA	CVS	REX	CRD	OD/EV	VST	VEG	
H'D097	RFM2	R/W	8		(TBC)*	—	—	—	—	—	—	FDS	
H'D098	CTVC	R/W	8	16	CEX	CEG	—	—	—	CFG	HSW	CTL	Frequency divider
H'D099	CTLR	W	8		CTL7	CTL6	CTL5	CTL4	CTL3	CTL2	CTL1	CTL0	
H'D09A	CDVC	R/W	8	16	MCGain	—	CMK	CMN	DVTRG	CRF	CPS1	CPS0	
H'D09B	CDIVR1	W	8		—	CDV16	CDV15	CDV14	CDV13	CDV12	CDV11	CDV10	
H'D09C	CDIVR2	W	8	16	—	CDV26	CDV25	CDV24	CDV23	CDV22	CDV21	CDV20	
H'D09D	CTMR	W	8		—	—	CPM5	CPM4	CPM3	CPM2	CPM1	CPM0	
H'D09E	FGCR	W	8	16	—	—	—	—	—	—	—	DRF	
H'D0A0	SPMR	R/W	8	8	CTLSTOP	—	CFGCOM P	EXCELON	DPGSW	COMP	H.Amp.S W	C.Rot	Servo port control
H'D0A1	SPCR	R/W	8	8	—	—	—	SPCR4	SPCR3	SPCR2	SPCR1	SPCR0	
H'D0A2	SPDR	R/W	8	8	—	—	—	SPDR4	SPDR3	SPDR2	SPDR1	SPDR0	
H'D0A3	SVMCR	R/W	8	8	—	—	SVMCR5	SVMCR4	SVMCR3	SVMCR2	SVMCR1	SVMCR0	
H'D0A4	CTLGR	R/W	8	8	—	—	—	CTLFB	CTLGR3	CTLGR2	CTLGR1	CTLGR0	
H'D0B0	VTR	W	8	16	—	—	VTR5	VTR4	VTR3	VTR2	VTR1	VTR0	Sync detector
H'D0B1	HTR	W	8	16	—	—	—	—	HTR3	HTR2	HTR1	HTR0	
H'D0B2	HRTR	W	8	16	HRTR7	HRTR6	HRTR5	HRTR4	HRTR3	HRTR2	HRTR1	HRTR0	
H'D0B3	HPWR	W	8	16	—	—	—	—	HPWR3	HPWR2	HPWR1	HPWR0	
H'D0B4	NWR	W	8	16	—	—	NWR5	NWR4	NWR3	NWR2	NWR1	NWR0	
H'D0B5	NDR	W	8	16	NDR7	NDR6	NDR5	NDR4	NDR3	NDR2	NDR1	NDR0	
H'D0B6	SYNCR	R/W	8	16	—	—	—	—	NID/VD	NOIS	FLD	SYCT	

# Appendix B Internal I/O Registers

Address*	Register Name	R/W	Access	Bus Width	7	6	5	4	3	2	1	0	Module Name
H'D0B8	SIENR1	R/W	8	16	IEDR3	IEDR2	IEDR1	IECAP3	IECAP2	IECAP1	IEHSW2	IEHSW1	Servo interrupt control
H'D0B9	SIENR2	R/W	8	16	---	---	---	---	---	---	IESNC	IESTL	
H'D0BA	SIRQR1	R/W	8	16	IRRD3M3	IRRD3M2	IRRD3M1	IRRCAP3	IRRCAP2	IRRCAP1	IRRH3W2	IRRH3W1	
H'D0BB	SIRQR2	R/W	8	16	---	---	---	---	---	---	IRRSNC	IRRCTL	
H'D0C0	32 byte Data Buffer	R/W	8	8									32-byte buffer SCI2
H'D0C1		R/W	8	8									
H'D0C2		R/W	8	8									
H'D0C3		R/W	8	8									
H'D0C4		R/W	8	8									
H'D0C5		R/W	8	8									
H'D0C6		R/W	8	8									
H'D0C7		R/W	8	8									
H'D0C8		R/W	8	8									
H'D0C9		R/W	8	8									
H'D0CA		R/W	8	8									
H'D0CB		R/W	8	8									
H'D0CC		R/W	8	8									
H'D0CD		R/W	8	8									
H'D0CE		R/W	8	8									
H'D0CF		R/W	8	8									
H'D0D0		R/W	8	8									
H'D0D1		R/W	8	8									
H'D0D2		R/W	8	8									
H'D0D3		R/W	8	8									
H'D0D4		R/W	8	8									
H'D0D5		R/W	8	8									
H'D0D6		R/W	8	8									
H'D0D7		R/W	8	8									
H'D0D8		R/W	8	8									
H'D0D9		R/W	8	8									
H'D0DA		R/W	8	8									
H'D0DB		R/W	8	8									
H'D0DC		R/W	8	8									
H'D0DD		R/W	8	8									
H'D0DE		R/W	8	8									
H'D0DF		R/W	8	8									
H'D0E0	STAR	R/W	8	8	---	---	---	STA4	STA3	STA2	STA1	STA0	
H'D0E1	EDAR	R/W	8	8	---	---	---	EDA4	EDA3	EDA2	EDA1	EDA0	
H'D0E2	SCR2	R/W	8	8	TEIE	ABTIE	---	GAP1	GAP0	CKS2	CKS1	CKS0	
H'D0E3	SCSR2	R/W	8	8	TEI	---	---	SOL	ORER	WT	ABT	STF	



Address*	Register Name	R/W	Access	Bus Width	Bus								Module Name
					7	6	5	4	3	2	1	0	
H'D100	TIER	R/W	8	16	ICIAE	ICIBE	ICICE	ICIDE	OCIAE	OCIBE	OVIE	ICSA	Timer X1
H'D101	TCSRX	R/W	8	16	ICFA	ICFB	ICFC	ICFD	OCFA	OCFB	OVF	CCLRA	* OCRA and OCRB addresses are the same.
H'D102	FRCH	R/W	8/16	16	FRCH7	FRCH6	FRCH5	FRCH4	FRCH3	FRCH2	FRCH1	FRCH0	
H'D103	FRCL				FRCL7	FRCL6	FRCL5	FRCL4	FRCL3	FRCL2	FRCL1	FRCL0	
H'D104	OCRAH*	R/W	8/16	16	OCRAH7	OCRAH6	OCRAH5	OCRAH4	OCRAH3	OCRAH2	OCRAH1	OCRAH0	Switched by OCSR bit in IOCR.
H'D105	OCRAL*				OCRAL7	OCRAL6	OCRAL5	OCRAL4	OCRAL3	OCRAL2	OCRAL1	OCRAL0	
H'D104	OCRBH*	R/W	8/16	16	OCRBH7	OCRBH6	OCRBH5	OCRBH4	OCRBH3	OCRBH2	OCRBH1	OCRBH0	
H'D105	OCRBL*				OCRBL7	OCRBL6	OCRBL5	CORBL4	CORBL3	CORBL2	CORBL1	CORBL0	
H'D106	TCRX	R/W	8	16	IEDGA	IEDGB	IEDGC	IEDGD	BUFEA	FUFEB	CKS1	CKS0	
H'D107	TOCR	R/W	8	16	ICSB	ICSC	ICSD	OCSR	OEA	OEB	OLVLA	OLVLB	
H'D108	ICRAH	R	8/16	16	ICRAH7	ICRAH6	ICRAH5	ICRAH4	ICRAH3	ICRAH2	ICRAH1	ICRAH0	
H'D109	ICRAL				ICRAL7	ICRAL6	ICRAL5	ICRAL4	ICRAL3	ICRAL2	ICRAL1	ICRAL0	
H'D10A	ICRBH	R	8/16	16	ICRBH7	ICRBH6	ICRBH5	ICRBH4	ICRBH3	ICRBH2	ICRBH1	ICRBH0	
H'D10B	ICRBL				ICRBL7	ICRBL6	ICRBL5	ICRBL4	ICRBL3	ICRBL2	ICRBL1	ICRBL0	
H'D10C	ICRCH	R	8/16	16	ICRCH7	ICRCH6	ICRCH5	ICRCH4	ICRCH3	ICRCH2	ICRCH1	ICRCH0	
H'D10D	ICRCL				ICRCL7	ICRCL6	ICRCL5	ICRCL4	ICRCL3	ICRCL2	ICRCL1	ICRCL0	
H'D10E	ICRDH	R	8/16	16	ICRDH7	ICRDH6	ICRDH5	ICRDH4	ICRDH3	ICRDH2	ICRDH1	ICRDH0	
H'D10F	ICRDL				ICRDL7	ICRDL6	ICRDL5	ICRDL4	ICRDL3	ICRDL2	ICRDL1	ICRDL0	
H'D110	TMB	R/W	8	8	TMB17	TMB16	TMB15	—	—	TMP12	TMP11	TCB10	Timer B
H'D111	TCB	R	8	8	TCB17	TCB16	TCB15	TCB14	TCB13	TCB12	TCB11	TCB10	
H'D111	TLB	W	8	8	TLB17	TLB16	TLB15	TLB14	TLB13	TLB12	TLB11	TLB10	
H'D112	LMR	R/W	8	8	LMIF	LMIE	—	—	LMR3	LMR2	LMR1	LMR0	Timer L
H'D113	LTC	R	8	8	LTC7	LTC6	LTC5	LTC4	LTC3	LTC2	LTC1	LTC0	
H'D113	RCR	W	8	8	RCR7	RCR6	RCR5	RCR4	RCR3	RCR2	RCR1	RCR0	
H'D118	TMRM1	R/W	8	8	CLR2	AC/BR	RLD	RLCK	PS21	PC20	RLD/CAP	CPS	Timer R
H'D119	TMRM2	R/W	8	8	LAT	RS11	PS10	PS31	PS30	CP/SLM	CAPF	SLW	
H'D11A	TMRCP1	R	8	8	TMRC17	TMRC16	TMRC15	TMRC14	TMRC13	TMRC12	TMRC11	TMRC10	
H'D11B	TMRCP2	R	8	8	TMRC27	TMRC26	TMRC25	TMRC24	TMRC23	TMRC22	TMRC21	TMRC20	
H'D11C	TMRL1	W	8	8	TMR17	TMR16	TMR15	TMR14	TMR13	TMR12	TMR11	TMR10	
H'D11D	TMRL2	W	8	8	TMR27	TMR26	TMR25	TMR24	TMR23	TMR22	TMR21	TMR20	
H'D11E	TMRL3	W	8	8	TMR37	TMR36	TMR35	TMR34	TMR33	TMR32	TMR31	TMR30	
H'D11F	TMRCS	R/W	8	8	TMRI3E	TMRI2E	TMRI1E	TMRI3	TMRI2	TMRI1	—	—	
H'D120	PWDRL	W	8	8	PWDRL7	PWDRL6	PWDRL5	PWDRL4	PWDRL3	PWDRL2	PWDRL1	PWDRL0	14-bit PWM
H'D121	PWDRU	W	8	8	—	—	PWDRU5	PWDRU4	PWDRU3	PWDRU2	PWDRU1	PWDRU0	
H'D122	PWCR	R/W	8	8	—	—	—	—	—	—	—	PWMCRO	
H'D126	PWR0	W	8	8	PW07	PW06	PW05	PW04	PW03	PW02	PW01	PW00	8-bit PWM
H'D127	PWR1	W	8	8	PW17	PW16	PW15	PW14	PW13	PW12	PW11	PW10	
H'D128	PWR2	W	8	8	PW27	PW26	PW25	PW24	PW23	PW22	PW21	PW20	
H'D129	PWR3	W	8	8	PW37	PW36	PW35	PW34	PW33	PW32	PW31	PW30	
H'D12A	PW8CR	R/W	8	8	—	—	—	—	PWC3	PWC2	PWC1	PWC0	
H'D12C	ICR1	R	8	8	ICR17	ICR16	ICR15	ICR14	ICR13	ICR12	ICR11	CIR10	PSU
H'D12D	PCSR	R/W	8	8	ICIF	ICIE	ICEG	NCon/off	—	DCS2	DCS1	DCS0	

# Appendix B Internal I/O Registers

Address*	Register Name	R/W	Access	Bus Width	7	6	5	4	3	2	1	0	Module Name
H'D130	ADRH	R	16	8	ADR9	ADR8	ADR7	ADR6	ADR5	ADR4	ADR3	ADR2	A/D
H'D131	ADRL				ADR1	ADR0	—	—	—	—	—	—	
H'D132	AHRH	R	16	8	AHR9	AHR8	AHR7	AHR6	AHR5	AHR4	AHR3	AHR2	
H'D133	AHRL				AHR1	AHR0	—	—	—	—	—	—	
H'D134	ADCR	R/W	8	8	CK	—	HCH1	HCH0	SCH3	SCH2	SCH1	SCH0	
H'D135	ADCSR	R/W	8	8	SEND	HEND	ADIE	SST	HST	BUSY	SCNL		
H'D136	ADTSR	R/W	8	8	—	—	—	—	—	—	TRGS1	TRGS0	
H'D138	TLK	W	8/16	16	TLR27	TLR26	TLR25	TLR24	TLR23	TLR22	TLR21	TLR20	Timer J
H'D138	TCK	R	8/16	16	TLR17	TLR16	TLR15	TLR14	TLR13	TLR12	TLR11	TLR10	
H'D139	TLJ	W	8/16	16	TDR27	TDR26	TDR25	TDR24	TDR23	TDR22	TDR21	TDR20	
H'D139	TCJ	R	8/16	16	TDR17	TDR16	TDR15	TDR14	TDR13	TDR12	TDR11	TDR10	* The PS22 bit is available only in the H8S/2194 C Group.
H'D13A	TMJ	R/W	8/16	16	PS11	PS10	ST	8/16	PS21	PS20	TGL	T/R	
H'D13B	TMJC	R/W	8/16	16	BUZZ1	BUZZ0	MON1	MON0		TMJ2IE	TMJ1IE	(PS22)*	
H'D13C	TMJS	R/W	8/16	16	TMJ2I	TMJ1I	—	—	—	—	—	—	
H'D148	SMR1	R/W	8	8	C/ $\bar{A}$	CHR	PE	O/ $\bar{E}$	STOP	MP	CKS1	CKS0	Clock synchronization/start-stop sync SCI
H'D149	BRR1	R/W	8	8									
H'D14A	SCR1	R/W	8	8	TEI	RIE	TE	RE	MPIE	TEIE	CKE1	CKE0	
H'D14B	TDR1	R/W	8	8									
H'D14C	SSR1	R/W	8	8	TDRE	RDRF	ORER	FER	PER	TEMD	MPB	MPBT	
H'D14D	RDR1	R	8	8									
H'D14E	SCMR1	R/W	8	8	—	—	—	—	SDIR	SINV	—	SMIF	
H'D158	ICCR	R/W	8	8	ICE	IEIC	MST	TRS	ACKE	BBSY	IRIC	SCP	IIC interface
H'D159	ICSR	R/W	8	8	ESTP	STOP	IRTR	AASX	AL	AAS	ADZ	ACKB	* Access varies depending on ICE bit.
H'D15E	ICDR*	R/W	8	8	ICDR7	ICDR6	ICDR5	ICDR4	ICDR3	ICDR2	ICDR1	ICDR0	
H'D15E	SARX*	R/W	8	8	SVAX6	SVAX5	SVAX4	SVAX3	SVAX2	SVAX1	SVAX0	FSX	
H'D15F	ICMR*	R/W	8	8	MLS	WAIT	CKS2	CKS1	CKS0	BC2	BC1	BC0	
H'D15F	SAR*	R/W	8	8	SVA6	SVA5	SVA4	SVA3	SVA2	SVA1	SVA0	FS	
H'FFB0	TAR0	R/W	8	8	TA023	TA022	TA021	TA020	TA019	TA018	TA017	TA016	ATC
H'FFB1					TA015	TA014	TA013	TA012	TA011	TA010	TA009	TA008	
H'FFB2					TA007	TA006	TA005	TA004	TA003	TA002	TA001		
H'FFB3	TAR1	R/W	8	8	TA123	TA122	TA121	TA120	TA119	TA118	TA117	TA116	
H'FFB4					TA115	TA114	TA113	TA112	TA111	TA110	TA109	TA108	
H'FFB5					TA107	TA106	TA105	TA104	TA103	TA102	TA101		
H'FFB6	TAR2	R/W	8	8	TA223	TA222	TA221	TA220	TA219	TA218	TA217	TA216	
H'FFB7					TA215	TA214	TA213	TA212	TA211	TA210	TA209	TA208	
H'FFB8					TA207	TA206	TA205	TA204	TA203	TA202	TA201		
H'FFB9	TRCR	R/W	8	8	—	—	—	—	—	TRC2	TRC1	TRC0	
H'FFBA	TMA	R/W	8	8	TMAOV	TMAIE	—	—	TMA3	TMA2	TMA1	TMA0	Timer A
H'FFBB	TCA	R	8	8	TCA7	TCA6	TCA5	TCA4	TCA3	TCA2	TCA1	TCA0	
H'FFBC	WTCSR	R/W	8/16	16	OVF	WT/ $\bar{I}$ T	TME	RSTS	RST/ $\bar{N}$ MI	CKS2	CKS1	CKS0	WDT
H'FFBD	WTCNT	R/W	8/16	16									

Address*	Register Name	R/W	Access	Bus Width	Bus								Module Name	
					7	6	5	4	3	2	1	0		
H'FFC0	PDR0	R	8	8	PDR07	PDR06	PDR05	PDR04	PDR03	PDR02	PDR01	PDR00	Port data register	
H'FFC1	PDR1	R/W	8	8	PDR17	PDR16	PDR15	PDR14	PDR13	PDR12	PDR11	PDR10		
H'FFC2	PDR2	R/W	8	8	PDR27	PDR26	PDR25	PDR24	PDR23	PDR22	PDR21	PDR20		
H'FFC3	PDR3	R/W	8	8	PDR37	PDR36	PDR35	PDR34	PDR33	PDR32	PDR31	PDR30		
H'FFC4	PDR4	R/W	8	8	PDR47	PDR46	PDR45	PDR44	PDR43	PDR42	PDR41	PDR40		
H'FFC5	PDR5	R/W	8	8	—	—	—	—	PDR53	PDR52	PDR51	PDR50		
H'FFC6	PDR6	R/W	8	8	PDR67	PDR66	PDR65	PDR64	PDR63	PDR62	PDR61	PDR60		
H'FFC7	PDR7	R/W	8	8	PDR77	PDR76	PDR75	PDR74	PDR73	PDR72	PDR71	PDR70		
H'FFC8	PDR8	R/W	8	8	PDR87	PDR86	PDR85	PDR84	PDR83	PDR82	PDR81	PDR80	Port mode register	
H'FFCD	PMR0	R/W	8	8	PMR07	PMR06	PMR05	PMR04	PMR03	PMR02	PMR01	PMR00		
H'FFCE	PMR1	R/W	8	8	PMR17	PMR16	PMR15	PMR14	PMR13	PMR12	PMR11	PMR10		
H'FFCF	PMR2	R/W	8	8	PMR27	PMR26	PMR25	—	—	—	—	PMR20	Port mode register	
H'FFD0	PMR3	R/W	8	8	PMR37	PMR36	PMR35	PMR34	PMR33	PMR32	PMR31	PMR30		
H'FFD1	PCR1	W	8	8	PCR17	PCR16	PCR15	PCR14	PCR13	PCR12	PCR11	PCR10		
H'FFD2	PCR2	W	8	8	PCR27	PCR26	PCR25	PCR24	PCR23	PCR22	PCR21	PCR20	Port control register	
H'FFD3	PCR3	W	8	8	PCR37	PCR36	PCR35	PCR34	PCR33	PCR32	PCR31	PCR30		
H'FFD4	PCR4	W	8	8	PCR47	PCR46	PCR45	PCR44	PCR43	PCR42	PCR41	PCR40		
H'FFD5	PCR5	W	8	8	—	—	—	—	PCR53	PCR52	PCR51	PCR50		
H'FFD6	PCR6	W	8	8	PCR67	PCR66	PCR65	PCR64	PCR63	PCR62	PCR61	PCR60		
H'FFD7	PCR7	W	8	8	PCR77	PCR76	PCR75	PCR74	PCR73	PCR72	PCR71	PCR70		
H'FFD8	PCR8	W	8	8	PCR87	PCR86	PCR85	PCR84	PCR83	PCR82	PCR81	PCR380		
H'FFDB	PMR4	R/W	8	8	—	—	—	—	—	—	—	PMR40		Port mode register
H'FFDC	PMR5	R/W	8	8	—	—	—	—	PMR53	PMR52	PMR51	PMR50		
H'FFDD	PMR6	R/W	8	8	PMR67	PMR66	PMR65	PMR64	PMR63	PMR62	PMR61	PMR60		
H'FFDE	PMR7	R/W	8	8	PMR77	PMR76	PMR75	PMR74	PMR73	PMR72	PMR71	PMR70		
H'FFDF	PMR8	R/W	8	8	—	—	—	—	PMR83	PMR82	PMR81	PMR80		
H'FFE1	PUR1	R/W	8	8	PUR17	PUR16	PUR15	PUR14	PUR13	PUR12	PUR11	PUR10	Port pull-up select register	
H'FFE2	PUR2	R/W	8	8	PUR27	PUR26	PUR25	PUR24	PUR23	PUR22	PUR21	PUR20		
H'FFE3	PUR3	R/W	8	8	PUR37	PUR36	PUR35	PUR34	PUR33	PUR32	PUR31	PUR30		
H'FFE4	RTPEGR	R/W	8	8	—	—	—	—	—	—	RTPEGR1	RTPEGR0		
H'FFE5	RTPSR	R/W	8	8	RTPSR7	RTPSR6	RTPSR5	RTPSR4	RTPSR3	RTPSR2	RTPSR1	RTPSR0	RTP TRG select	
H'FFE8	SYSCR	R/W	8	8	—	—	INTM1	INTM0	XRST	NMIEG1	NMIEG0	—	System control register	
H'FFE9	MDCR	R/W	8	8	—	—	—	—	—	—	—	MDS0		
H'FFEA	SBYCR	R/W	8	8	SSBY	STS2	STS1	STS0	—	—	SCK1	SCK0	Port data register	
H'FFEB	LPWRCR	R/W	8	8	DTON	LSON	NESEL	—	—	—	SA1	SA0		
H'FFEC	MSTPCRH	R/W	8	8	MSTP15	MSTP14	MSTP13	MSTP12	MSTP11	MSTP10	MSTP9	MSTP8		
H'FFED	MSTPCRL	R/W	8	8	MSTP7	MSTP6	MSTP5	MSTP4	MSTP3	MSTP2	MSTP1	MSTP0		
H'FFEE	STCR	R/W	8	8	—	IICX	IICRST	—	FLASHE	—	—	—		
H'FFF0	IEGR	R/W	8	8	—	IRQ5EG	IRQ4EG	IRQ3EG	IRQ2EG	IRQ1EG	IRQ0EG1	IRQ0EG0		IRQ edge
H'FFF1	IENR	R/W	8	8	—	—	IRQ5E	IRQ4E	IRQ3E	IRQ2E	IRQ1E	IRQ0E		IRQ enable
H'FFF2	IRQR	R/W	8	8	—	—	IRQ5F	IRQ4F	IRQ3F	IRQ2F	IRQ1F	IRQ0F		IRQ status

## Appendix B Internal I/O Registers

Address*	Register Name	R/W	Access	Bus Width	7	6	5	4	3	2	1	0	Module Name
H'FFF3	ICRA	R/W	8	8	ICRA7	ICRA6	ICRA5	ICRA4	ICRA3	ICRA2	ICRA1	ICRA0	IRQ priority control
H'FFF4	ICRB	R/W	8	8	ICRB7	ICRB6	ICRB5	ICRB4	ICRB3	ICRB2	ICRB1	ICRB0	
H'FFF5	ICRC	R/W	8	8	ICRC7	ICRC6	ICRC5	ICRC4	ICRC3	ICRC2	ICRC1	ICRC0	
H'FFF6	ICRD	R/W	8	8	ICRD7	ICRD6	ICRD5	ICRD4	ICRD3	ICRD2	ICRD1	ICRD0	
H'FFF8	FLMCR1	R/W	8	8	FWE	SWE	—	—	EV	PV	E	P	Only for FLASH version.
H'FFF9	FLMCR2	R/W	8	8	FLER	—	—	—	—	—	ESU	PSU	
H'FFFA	EBR1	R/W	8	8	—	—	—	—	—	—	EB9	EB8	Only for FLASH version in the H8S/2194 C
H'FFFB	EBR2	R/W	8	8	EB7	EB6	EB5	EB4	EB3	EB2	EB1	EB0	
H'FFF8	FLMCR1	R/W	8	8	FWE	SWE	ESU1	PSU1	EV1	PV1	E1	P1	
H'FFF9	FLMCR2	R/W	8	8	FLER	—	ESU2	PSU2	EV2	PV2	E2	P2	
F'FFFA	EBR1	R/W	8	8	—	—	EB13	EB12	EB11	EB10	EB9	EB8	Only for FLASH version in the H8S/2194 C
F'FFFB	EBR2	R/W	8	8	EB7	EB6	EB5	EB4	EB3	EB2	EB1	EB0	

Note: \* Lower 16 bits of the address.

## B.2 Function List

**H'D000: Gain Constant DGKp: Drum Digital Filter**

**H'D001: Gain Constant DGKp: Drum Digital Filter**

**H'D002: Gain Constant DGKs: Drum Digital Filter**

**H'D003: Gain Constant DGKs: Drum Digital Filter**

Bit :	15	14	13	12	11	10	9	8	7	6	5	4	3	2	1	0
Initial value :	*	*	*	*	*	*	*	*	*	*	*	*	*	*	*	*
R/W :	W	W	W	W	W	W	W	W	W	W	W	W	W	W	W	W

Legend: \* Undetermined

**H'D004: Coefficient DAp: Drum Digital Filter**

**H'D005: Coefficient DAp: Drum Digital Filter**

**H'D006: Coefficient DBp: Drum Digital Filter**

**H'D007: Coefficient DBp: Drum Digital Filter**

**H'D008: Coefficient DAs: Drum Digital Filter**

**H'D009: Coefficient DAs: Drum Digital Filter**

**H'D00A: Coefficient DBs: Drum Digital Filter**

**H'D00B: Coefficient DBs: Drum Digital Filter**

Bit :	15	14	13	12	11	10	9	8	7	6	5	4	3	2	1	0
Initial value :	*	*	*	*	*	*	*	*	*	*	*	*	*	*	*	*
R/W :	W	W	W	W	W	W	W	W	W	W	W	W	W	W	W	W

Legend: \* Undetermined

**H'D00C: Offset DOfp: Drum Digital Filter****H'D00D: Offset DOfp: Drum Digital Filter****H'D00E: Offset DOfs: Drum Digital Filter****H'D00F: Offset DOfs: Drum Digital Filter**

Bit :	15	14	13	12	11	10	9	8	7	6	5	4	3	2	1	0
	<input type="checkbox"/>	<input type="checkbox"/>	<input type="checkbox"/>	<input type="checkbox"/>	<input type="checkbox"/>	<input type="checkbox"/>	<input type="checkbox"/>	<input type="checkbox"/>	<input type="checkbox"/>	<input type="checkbox"/>	<input type="checkbox"/>	<input type="checkbox"/>	<input type="checkbox"/>	<input type="checkbox"/>	<input type="checkbox"/>	<input type="checkbox"/>
Initial value :	*	*	*	*	*	*	*	*	*	*	*	*	*	*	*	*
R/W :	W	W	W	W	W	W	W	W	W	W	W	W	W	W	W	W

Legend: \* Undetermined

**H'D010: Gain Constant CGKp: Capstan Digital Filter****H'D011: Gain Constant CGKp: Capstan Digital Filter****H'D012: Gain Constant CGKs: Capstan Digital Filter****H'D013: Gain Constant CGKs: Capstan Digital Filter**

Bit :	15	14	13	12	11	10	9	8	7	6	5	4	3	2	1	0
	<input type="checkbox"/>	<input type="checkbox"/>	<input type="checkbox"/>	<input type="checkbox"/>	<input type="checkbox"/>	<input type="checkbox"/>	<input type="checkbox"/>	<input type="checkbox"/>	<input type="checkbox"/>	<input type="checkbox"/>	<input type="checkbox"/>	<input type="checkbox"/>	<input type="checkbox"/>	<input type="checkbox"/>	<input type="checkbox"/>	<input type="checkbox"/>
Initial value :	*	*	*	*	*	*	*	*	*	*	*	*	*	*	*	*
R/W :	W	W	W	W	W	W	W	W	W	W	W	W	W	W	W	W

Legend: \* Undetermined

**H'D014: Coefficient CAP: Capstan Digital Filter****H'D015: Coefficient CAP: Capstan Digital Filter****H'D016: Coefficient CBp: Capstan Digital Filter****H'D017: Coefficient CBp: Capstan Digital Filter****H'D018: Coefficient CAs: Capstan Digital Filter****H'D019: Coefficient CAs: Capstan Digital Filter****H'D01A: Coefficient CBs: Capstan Digital Filter****H'D01B: Coefficient CBs: Capstan Digital Filter**

Bit :	15	14	13	12	11	10	9	8	7	6	5	4	3	2	1	0
Initial value :	*	*	*	*	*	*	*	*	*	*	*	*	*	*	*	*
R/W :	W	W	W	W	W	W	W	W	W	W	W	W	W	W	W	W

Legend: \* Undetermined

**H'D01C: Offset COfp: Capstan Digital Filter****H'D01D: Offset COfp: Capstan Digital Filter****H'D01E: Offset COfs: Capstan Digital Filter****H'D01F: Offset COfs: Capstan Digital Filter**

Bit :	15	14	13	12	11	10	9	8	7	6	5	4	3	2	1	0
Initial value :	*	*	*	*	*	*	*	*	*	*	*	*	*	*	*	*
R/W :	W	W	W	W	W	W	W	W	W	W	W	W	W	W	W	W

Legend: \* Undetermined

**H'D020: Delay Initialization Register DZs: Digital filter**

**H'D021: Delay Initialization Register DZs: Digital filter**

**H'D022: Delay Initialization Register DZp: Digital filter**

**H'D023: Delay Initialization Register DZp: Digital filter**

**H'D024: Delay Initialization Register CZs: Digital filter**

**H'D025: Delay Initialization Register CZs: Digital filter**

**H'D026: Delay Initialization Register CZp: Digital filter**

**H'D027: Delay Initialization Register CZp: Digital filter**

Bit :	15	14	13	12	11	10	9	8	7	6	5	4	3	2	1	0
Initial value :	1	1	1	1	0	0	0	0	0	0	0	0	0	0	0	0
R/W :	—	—	—	—	W	W	W	W	W	W	W	W	W	W	W	W



## H'D028: Drum System Digital Filter Control Register DFIC: Digital Filter

Bit :	7	6	5	4	3	2	1	0
	—	DROV	DPHA	DZPON	DZSON	DSG2	DSG1	DSG0
Initial value :	1	0	0	0	0	0	0	0
R/W :	—	R/(W)*	R/(W)	R/W	R/W	R/W	R/W	R/W

## Drum system gain control bit

DSG2	DSG1	DSG0	Description
0	0	0	1
		1	2
	1	0	4
		1	8
1	0	0	16
		1	( 32)*
	1	0	( 64)*
		1	Invalid (do not set)

Note: \* Optional

Drum speed system Z<sup>-1</sup> initialization bit

0	Speed system Z <sup>-1</sup> reflects DZs value.
1	Speed system Z <sup>-1</sup> does not reflect DZs value.

Drum phase system Z<sup>-1</sup> initialization bit

0	Phase system Z <sup>-1</sup> reflects DZp value.
1	Phase system Z <sup>-1</sup> does not reflect DZp value.

## Drum phase system filter computation start bit

0	Phase system filter computation is OFF. Phase system computation result Y is not added to Es.
1	Phase system filter computation is ON.

## Drum system range over flag

0	Filter computation result does not exceed 12 bits.
1	Filter computation result exceeds 12 bits.

Note: \* Only 0 can be written.

**H'D029: Capstan System Digital Filter Control Register CFIC: Digital Filter**

Bit :	7	6	5	4	3	2	1	0
	—	CROV	CPHA	CZPON	CZSON	CSG2	CSG1	CSG0
Initial value :	1	0	0	0	0	0	0	0
R/W :	—	R/(W)*	R/(W)	R/W	R/W	R/W	R/W	R/W

Capstan system gain control bit

CSG2	CSG1	CSG0	Description
0	0	0	1
		1	2
	1	0	4
1	0	1	8
		0	16
	1	0	( 32)*
		0	( 64)*
		1	Invalid (do not set)

Note: \* Setting optional

Capstan speed system Z<sup>-1</sup> initialization bit

0	Speed system Z <sup>-1</sup> reflects CZs value.
1	Speed system Z <sup>-1</sup> does not reflect CZs value.

Capstan phase system Z<sup>-1</sup> initialization bit

0	Phase system Z <sup>-1</sup> reflects CZp value.
1	Phase system Z <sup>-1</sup> does not reflect CZp value.

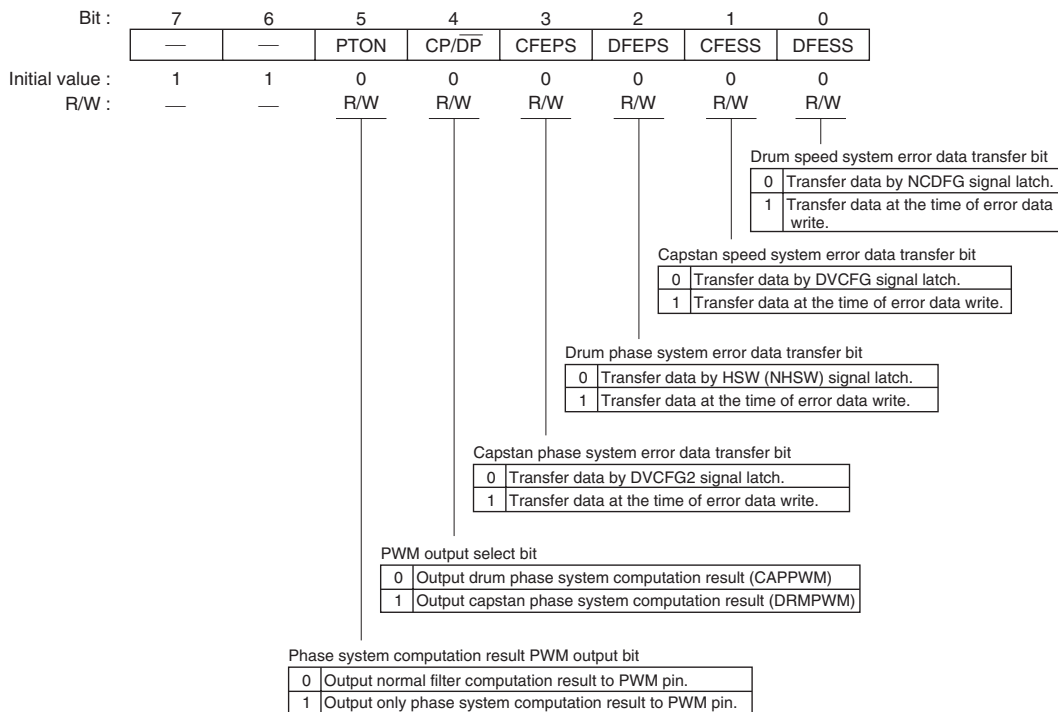
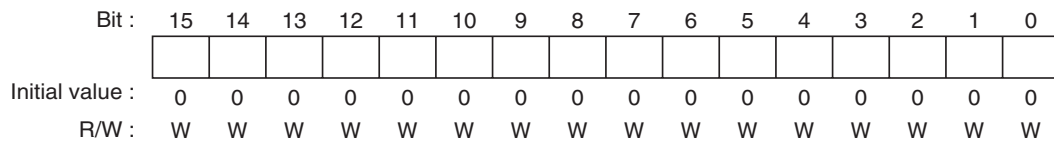
Capstan phase system filter computation start bit

0	Phase system filter computation is OFF. Phase system computation result Y is not added to Es.
1	Phase system filter computation is ON.

Capstan system range over flag

0	Filter computation result does not exceed 12 bits.
1	Filter computation result exceeds 12 bits.

Note: \* Only 0 can be written.

**H'D02A: Digital Filter Control Register DFUCR: Digital Filter****H'D030: Specified DFG Speed Preset Data Register DFPR: Drum Error Detector****H'D031: Specified DFG Speed Preset Data Register DFPR: Drum Error Detector**

**H'D032: DFG Speed Error Data Register DFER: Drum Error Detector****H'D033: DFG Speed Error Data Register DFER: Drum Error Detector**

Bit :	15	14	13	12	11	10	9	8	7	6	5	4	3	2	1	0
	<input type="checkbox"/>	<input type="checkbox"/>	<input type="checkbox"/>	<input type="checkbox"/>	<input type="checkbox"/>	<input type="checkbox"/>	<input type="checkbox"/>	<input type="checkbox"/>	<input type="checkbox"/>	<input type="checkbox"/>	<input type="checkbox"/>	<input type="checkbox"/>	<input type="checkbox"/>	<input type="checkbox"/>	<input type="checkbox"/>	<input type="checkbox"/>
Initial value :	0	0	0	0	0	0	0	0	0	0	0	0	0	0	0	0
R/W :	R*/W	R*/W	R*/W	R*/W	R*/W	R*/W	R*/W	R*/W	R*/W	R*/W	R*/W	R*/W	R*/W	R*/W	R*/W	R*/W

Note: \* Note that only detected error data can be read.

**H'D034: DFG Lock Upper Data Register DFRUDR: Drum Error Detector****H'D035: DFG Lock Upper Data Register DFRUDR: Drum Error Detector**

Bit :	15	14	13	12	11	10	9	8	7	6	5	4	3	2	1	0
	<input type="checkbox"/>	<input type="checkbox"/>	<input type="checkbox"/>	<input type="checkbox"/>	<input type="checkbox"/>	<input type="checkbox"/>	<input type="checkbox"/>	<input type="checkbox"/>	<input type="checkbox"/>	<input type="checkbox"/>	<input type="checkbox"/>	<input type="checkbox"/>	<input type="checkbox"/>	<input type="checkbox"/>	<input type="checkbox"/>	<input type="checkbox"/>
Initial value :	0	1	1	1	1	1	1	1	1	1	1	1	1	1	1	1
R/W :	W	W	W	W	W	W	W	W	W	W	W	W	W	W	W	W

**H'D036: DFG Lock Lower Data Register DFRLDR: Drum Error Detector****H'D037: DFG Lock Lower Data Register DFRLDR: Drum Error Detector**

Bit :	15	14	13	12	11	10	9	8	7	6	5	4	3	2	1	0
	<input type="checkbox"/>	<input type="checkbox"/>	<input type="checkbox"/>	<input type="checkbox"/>	<input type="checkbox"/>	<input type="checkbox"/>	<input type="checkbox"/>	<input type="checkbox"/>	<input type="checkbox"/>	<input type="checkbox"/>	<input type="checkbox"/>	<input type="checkbox"/>	<input type="checkbox"/>	<input type="checkbox"/>	<input type="checkbox"/>	<input type="checkbox"/>
Initial value :	1	0	0	0	0	0	0	0	0	0	0	0	0	0	0	0
R/W :	W	W	W	W	W	W	W	W	W	W	W	W	W	W	W	W

**H'D038: Drum Speed Error Detection Control Register DFVCR: Drum Error Detector**

Bit :	7	6	5	4	3	2	1	0
	DFCS1	DFCS0	DFOVF	DFRFON	DF-R/UNR	DPCNT	DFRCS1	DFRCS0
Initial value :	0	0	0	0	0	0	0	0
R/W :	R/W	R/W	R/(W)*1	R/W	R	R/W	(R)/W*2	(R)/W*2

Drum lock counter setting bit

DFRCS1	DFRCS0	Description
0	0	Underflow by 1 lock detection
	1	Underflow by 2 lock detections
1	0	Underflow by 3 lock detections
	1	Underflow by 4 lock detections

Drum phase system filter computation auto start bit

0	Filter computation by drum lock detection is not executed.
1	Filter computation of phase system is executed at the time of drum lock detection.

Drum lock flag

0	Drum speed system is not locked.
1	Drum speed system is locked.

Error data limit function select bit

0	Limit function OFF
1	Limit function ON

Counter overflow flag

0	Normal status
1	Counter overflows.

Clock source select bit

DFCS1	DFCS0	Description
0	0	$\phi$ s
	1	$\phi$ s/2
1	0	$\phi$ s/4
	1	$\phi$ s/8

Notes: 1. Only 0 can be written.

2. When read, counter value is read.

**H'D039: Drum Phase Error Detection Control Register DPGCR: Drum Error Detector**

Bit :	7	6	5	4	3	2	1	0
	DPCS1	DPCS0	DPOVF	N/V	HSWES	—	—	—
Initial value :	0	0	0	0	0	1	1	1
R/W :	R/W	R/W	R/(W)*	R/W	R/W	—	—	—

Edge select bit	
0	Latch at rising edge
1	Latch at falling edge

Error data latch signal select bit	
0	HSW (VideoFF) signal
1	NHSW (NarrowFF) signal

Counter overflow flag	
0	Normal status
1	Counter overflows.

Clock source select bit		
DPCS1	DPCS0	Description
0	0	$\phi_s$
	1	$\phi_s/2$
1	0	$\phi_s/3$
	1	$\phi_s/4$

Note: \* Only 0 can be written.

**H'D03A: Specified Drum Phase Preset Data Register 2 DPPR2: Drum Error Detector**

Bit :	15	14	13	12	11	10	9	8	7	6	5	4	3	2	1	0
Initial value :	0	0	0	0	0	0	0	0	0	0	0	0	0	0	0	0
R/W :	W	W	W	W	W	W	W	W	W	W	W	W	W	W	W	W

**H'D03C: Specified Drum Phase Preset Data Register 1 DPPR1: Drum Error Detector**

Bit :	7	6	5	4	3	2	1	0
	—	—	—	—				
Initial value :	1	1	1	1	0	0	0	0
R/W :	—	—	—	—	W	W	W	W

**H'D03D: Drum Phase Error Data Register 1 DPER1: Drum Error Detector**

Bit :	7	6	5	4	3	2	1	0
	—	—	—	—				
Initial value :	1	1	1	1	0	0	0	0
R/W :	—	—	—	—	R*/W	R*/W	R*/W	R*/W

Note: \* Note that only detected error data can be read.

**H'D03E: Drum Phase Error Data Register 2 DPER2: Drum Error Detector**

Bit :	15	14	13	12	11	10	9	8	7	6	5	4	3	2	1	0
Initial value :	0	0	0	0	0	0	0	0	0	0	0	0	0	0	0	0
R/W :	R*/W	R*/W	R*/W	R*/W	R*/W	R*/W	R*/W	R*/W	R*/W	R*/W	R*/W	R*/W	R*/W	R*/W	R*/W	R*/W

Note: \* Note that only detected error data can be read.

**H'D050: Specified CFG Speed Preset Data Register CFPR: Capstan Error Detector**

Bit :	15	14	13	12	11	10	9	8	7	6	5	4	3	2	1	0
Initial value :	0	0	0	0	0	0	0	0	0	0	0	0	0	0	0	0
R/W :	W	W	W	W	W	W	W	W	W	W	W	W	W	W	W	W

**H'D052: CFG Speed Error Data Register CFER: Capstan Error Detector**

Bit :	15	14	13	12	11	10	9	8	7	6	5	4	3	2	1	0
Initial value :	0	0	0	0	0	0	0	0	0	0	0	0	0	0	0	0
R/W :	R*/W	R*/W	R*/W	R*/W	R*/W	R*/W	R*/W	R*/W	R*/W	R*/W	R*/W	R*/W	R*/W	R*/W	R*/W	R*/W

Note: \* Note that only detected error data can be read.

**H'D054: CFG Lock Upper Data Register CFRUDR: Capstan Error Detector**

Bit :	15	14	13	12	11	10	9	8	7	6	5	4	3	2	1	0
Initial value :	0	1	1	1	1	1	1	1	1	1	1	1	1	1	1	1
R/W :	W	W	W	W	W	W	W	W	W	W	W	W	W	W	W	W

### H'D056: CFG Lock Lower Data Register CFRLDR: Capstan Error Detector

Bit :	15	14	13	12	11	10	9	8	7	6	5	4	3	2	1	0
Initial value :	1	0	0	0	0	0	0	0	0	0	0	0	0	0	0	0
R/W :	W	W	W	W	W	W	W	W	W	W	W	W	W	W	W	W

### H'D058: Capstan Speed Error Detection Control Register

#### CFVCR: Capstan Error Detector

Bit :	7	6	5	4	3	2	1	0
	CFCS1	CFCS0	CFOVF	CFRFON	CF-R/UNR	CPCNT	CFRCS1	CFRCS0
Initial value :	0	0	0	0	0	0	0	0
R/W :	R/W	R/W	R/(W) <sup>*1</sup>	R/W	R	R/W	(R)/W <sup>*2</sup>	(R)/W <sup>*2</sup>

Capstan lock counter setting bit

CFRCS1	CFRCS0	Description
0	0	Underflow by 1 lock detection
	1	Underflow by 2 lock detections
1	0	Underflow by 3 lock detections
	1	Underflow by 4 lock detections

Capstan phase system filter computation auto start bit

0	Filter computation by capstan lock detection is not excuted.
1	Filter computation of phase system is executed at the time of drum lock detection.

Capstan lock flag

0	Capstan speed system is not locked.
1	Capstan speed system is locked.

Error data limit function select bit

0	Limit function OFF
1	Limit function ON

Counter overflow flag

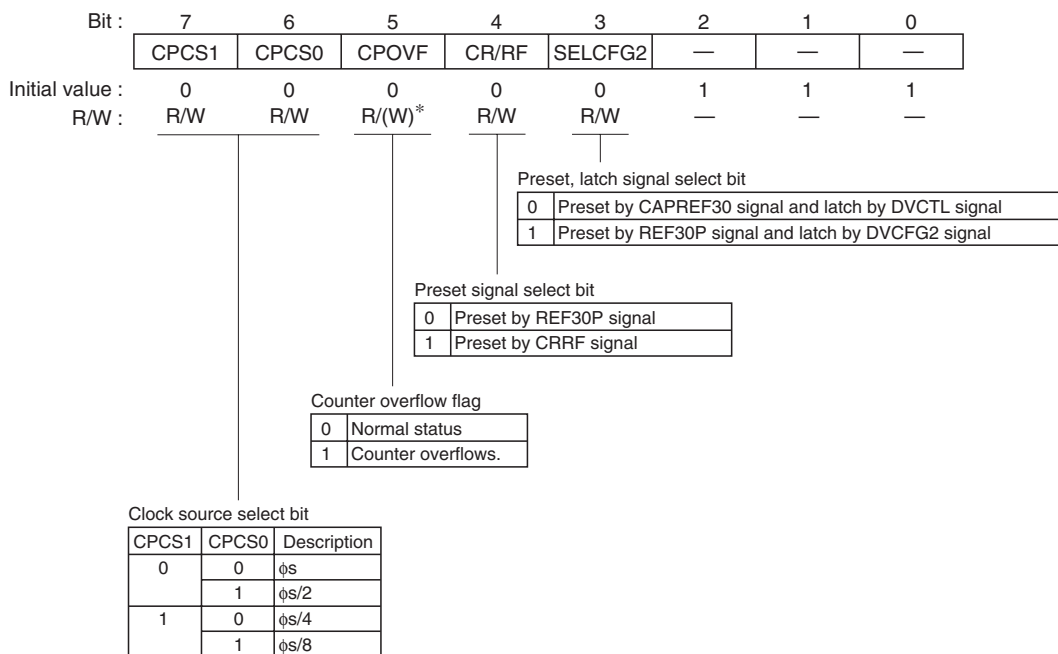
0	Normal status
1	Counter overflows.

Clock source select bit

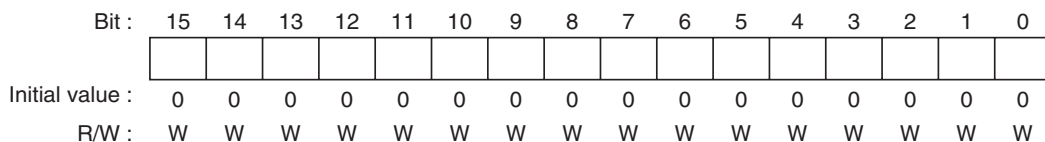
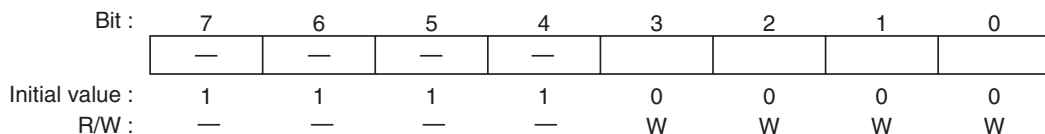
CFCS1	CFCS0	Description
0	0	$\phi_S$
	1	$\phi_S/2$
1	0	$\phi_S/4$
	1	$\phi_S/8$

- Notes: 1. Only 0 can be written.  
 2. When read, counter value is read.



**H'D059: Capstan Phase Error Detection Control Register****CPGCR: Capstan Error Detector**

Note: \* Only 0 can be written.

**H'D05A: Specified Capstan Phase Preset Data Register 2 CPPR2: Capstan Error Detector****H'D05C: Specified Capstan Phase Preset Data Register 1 CPPR1: Capstan Error Detector**

**H'D05D: Capstan Phase Error Data Register 1 CPER1: Capstan Error Detector**

Bit :	7	6	5	4	3	2	1	0
	—	—	—	—				
Initial value :	1	1	1	1	0	0	0	0
R/W :	—	—	—	—	R*/W	R*/W	R*/W	R*/W

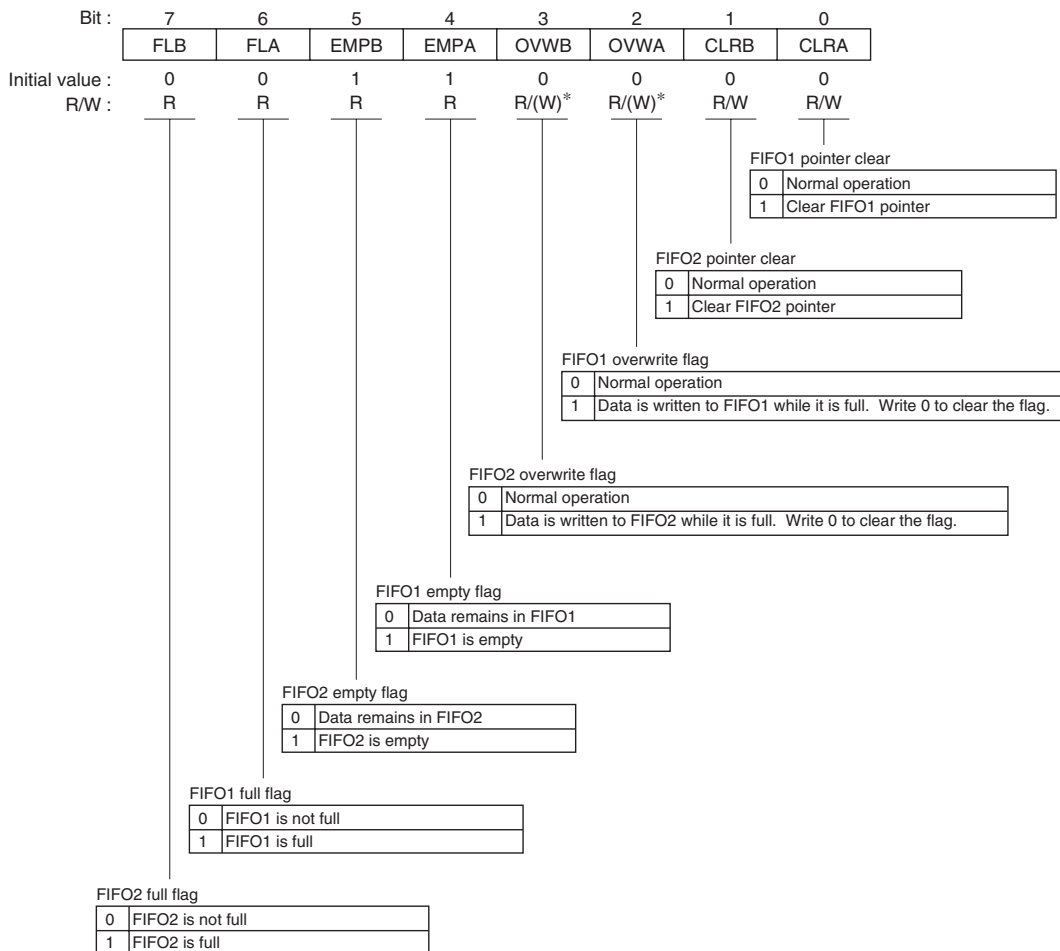
Note: \* Note that only detected error data can be read.

**H'D05E: Capstan Phase Error Data Register 2 CPER2: Capstan Error Detector**

Bit :	15	14	13	12	11	10	9	8	7	6	5	4	3	2	1	0
Initial value :	0	0	0	0	0	0	0	0	0	0	0	0	0	0	0	0
R/W :	R*/W	R*/W	R*/W	R*/W	R*/W	R*/W	R*/W	R*/W	R*/W	R*/W	R*/W	R*/W	R*/W	R*/W	R*/W	R*/W

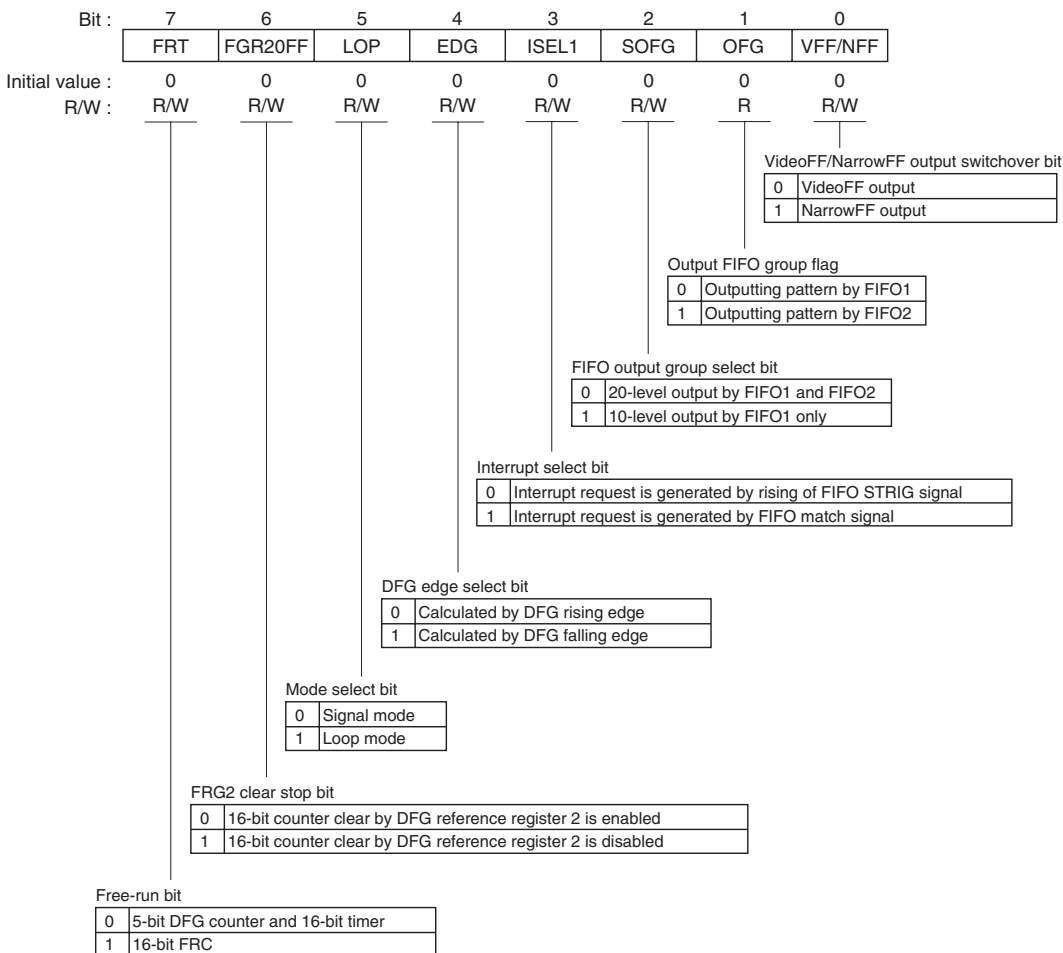
Note: \* Note that only detected error data can be read.

## H'D060: HSW Mode Register 1 HSM1: HSW Timing Generator



Note: \* Only 0 can be written.

## H'D061: HSW Mode Register 2 HSM2: HSW Timing Generator



**H'D062: HSW Loop Stage Setting Register HSLP: HSW Timing Generator**

Bit :	7	6	5	4	3	2	1	0
	LOB3	LOB2	LOB1	LOB0	LOA3	LOA2	LOA1	LOA0

Initial value : \* \* \* \* \* \* \* \*

R/W : R/W R/W R/W R/W R/W R/W R/W R/W

FIFO1 stage setting bit

HSM2	HSLP				Description
	Bit 5	Bit 3	Bit 2	Bit 1	
LOP	LOA3	LOA2	LOA1	LOA0	
0	*	*	*	*	Single mode
1	0	0	0	0	Output stage 0 of FIFO1
				1	Output stage 0 and 1 of FIFO1
			1	0	Output stage 0 to 2 of FIFO1
				1	Output stage 0 to 3 of FIFO1
	1	1	0	0	Output stage 0 to 4 of FIFO1
				1	Output stage 0 to 5 of FIFO1
			1	0	Output stage 0 to 6 of FIFO1
				1	Output stage 0 to 7 of FIFO1
	1	0	0	Output stage 0 to 8 of FIFO1	
			1	Output stage 0 to 9 of FIFO1	
1	1	1	0	Setting disabled	
			1		
			0		
			1		

Legend: \* Don't care.

FIFO2 stage setting bit

HSM2	HSLP				Description
	Bit 7	Bit 6	Bit 5	Bit 4	
LOP	LOB3	LOB2	LOB1	LOB0	
0	*	*	*	*	Single mode
1	0	0	0	0	Output stage 0 of FIFO2
				1	Output stage 0 and 1 of FIFO2
			1	0	Output stage 0 to 2 of FIFO2
				1	Output stage 0 to 3 of FIFO2
	1	1	0	0	Output stage 0 to 4 of FIFO2
				1	Output stage 0 to 5 of FIFO2
			1	0	Output stage 0 to 6 of FIFO2
				1	Output stage 0 to 7 of FIFO2
	1	0	0	Output stage 0 to 8 of FIFO2	
			1	Output stage 0 to 9 of FIFO2	
1	1	1	0	Setting disabled	
			1		
			0		
			1		

Legend: \* Don't care.

**H'D064: FIFO Output Pattern Register 1 FPDRA: HSW Timing Generator**

Bit :	15	14	13	12	11	10	9	8
	—	ADTRGA	STRIGA	NarrowFFA	VFFA	AFFA	VpulseA	MlevelA
Initial value :	1	*	*	*	*	*	*	*
R/W :	—	W	W	W	W	W	W	W

Bit :	7	6	5	4	3	2	1	0
	PPGA7	PPGA6	PPGA5	PPGA4	PPGA3	PPGA2	PPGA1	PPGA0
Initial value :	*	*	*	*	*	*	*	*
R/W :	W	W	W	W	W	W	W	W

Legend: \* Undetermined

**H'D066: FIFO Timing Pattern Register 1 FTPRA: HSW Timing Generator**

Bit :	15	14	13	12	11	10	9	8	7	6	5	4	3	2	1	0
	FTPRA15	FTPRA14	FTPRA13	FTPRA12	FTPRA11	FTPRA10	FTPRA9	FTPRA8	FTPRA7	FTPRA6	FTPRA5	FTPRA4	FTPRA3	FTPRA2	FTPRA1	FTPRA0
Initial value :	*	*	*	*	*	*	*	*	*	*	*	*	*	*	*	*
R/W :	W	W	W	W	W	W	W	W	W	W	W	W	W	W	W	W

Legend: \* Undetermined

**H'D066: FIFO Timer Capture Register 1 FTCTR: HSW Timing Generator**

Bit :	15	14	13	12	11	10	9	8	7	6	5	4	3	2	1	0
	FTCTR15	FTCTR14	FTCTR13	FTCTR12	FTCTR11	FTCTR10	FTCTR9	FTCTR8	FTCTR7	FTCTR6	FTCTR5	FTCTR4	FTCTR3	FTCTR2	FTCTR1	FTCTR0
Initial value :	0	0	0	0	0	0	0	0	0	0	0	0	0	0	0	0
R/W :	R	R	R	R	R	R	R	R	R	R	R	R	R	R	R	R

**H'D068: FIFO Output Pattern Register 2 FPDRA: HSW Timing Generator**

Bit :	15	14	13	12	11	10	9	8
	—	ADTRGB	STRIGB	NarrowFFB	VFFB	AFFB	VpulseB	MlevelB
Initial value :	1	*	*	*	*	*	*	*
R/W :	—	W	W	W	W	W	W	W

Bit :	7	6	5	4	3	2	1	0
	PPGB7	PPGB6	PPGB5	PPGB4	PPGB3	PPGB2	PPGB1	PPGB0
Initial value :	*	*	*	*	*	*	*	*
R/W :	W	W	W	W	W	W	W	W

Note: \* Undetermined

**H'D06A: FIFO Timing Pattern Register 2 FTPRB: HSW Timing Generator**

Bit :	15	14	13	12	11	10	9	8	7	6	5	4	3	2	1	0
	FTPRB15	FTPRB14	FTPRB13	FTPRB12	FTPRB11	FTPRB10	FTPRB9	FTPRB8	FTPRB7	FTPRB6	FTPRB5	FTPRB4	FTPRB3	FTPRB2	FTPRB1	FTPRB0

Initial value : \* \* \* \* \* \* \* \* \* \* \* \* \* \* \*

R/W : W W W W W W W W W W W W W W W W

Note: \* Undetermined

**H'D06C: DFG Reference Register 1 DFCRA: HSW Timing Generator**

Bit :	7	6	5	4	3	2	1	0
	ISEL2	CCLR	CKSL	DFCRA4	DFCRA3	DFCRA2	DFCRA1	DFCRA0

Initial value : 0 0 0 \* \* \* \* \*

R/W : W W W W W W W W

16-bit counter clock source select bit

0	$\phi$ s/4
1	$\phi$ s/8

DFG counter clear bit

0	Normal operation
1	Clear 5-bit DFG counter

Interrupt select bit

0	Interrupt request is generated by clear signal of 16-bit timer counter
1	Interrupt request is generated by VD signal in PB mode

**H'D06C: DFG Reference Count Register DFCTR: HSW Timing Generator**

Bit :	7	6	5	4	3	2	1	0
	—	—	—	DFCTR4	DFCTR3	DFCTR2	DFCTR1	DFCTR0

Initial value : 1 1 1 0 0 0 0 0

R/W : — — — R R R R R

**H'D06D: DFG Reference Register 2 DFCRB: HSW Timing Generator**

Bit :	7	6	5	4	3	2	1	0
	—	—	—	DFCRB4	DFCRB3	DFCRB2	DFCRB1	DFCRB0

Initial value : 1 1 1 \* \* \* \*

R/W : — — — W W W W W

Note: \* Undetermined

**H'D06E: Special Effect Playback Control Register****CHCR: 4-head Special Effect Playback Circuit**

Bit :	7	6	5	4	3	2	1	0
	V/N	HSWPOL	CRH	HAH	SIG3	SIG2	SIG1	SIG0
Initial value :	0	0	0	0	0	0	0	0
R/W :	W	W	W	W	W	W	W	W

Signal control bits

SIG3	SIG2	SIG1	SIG0	Output pin	
				C.Rotary	H.Amp SW
0	0	*	*	L	L
				HSW	L
	1	0	0	HSW	H
				L	HSW
1	0	0	*	HSW EX-OR COMP	COMP
				HSW EX-NOR COMP	COMP
	1	0	0	HSW EX-OR RTP0	RTP0
				HSW EX-NOR RTP0	RTP0

Note: \* Don't care.

H.AmpSW synchronization control bit

0	Synchronous
1	Asynchronous

C.Rotary synchronization control bit

0	Synchronous
1	Asynchronous

COMP polarity select bit

0	Positive
1	Negative

HSW output signal select bit

0	VideoFF signal output
1	Narrow FF signal output



**H'D06F: Additional V Control Register ADDVR: Additional V Signal Generator**

Bit :	7	6	5	4	3	2	1	0
	—	—	—	HMSK	Hi-Z	CUT	VPON	POL
Initial value :	1	1	1	0	0	0	0	0
R/W :	—	—	—	R/W	R/W	R/W	R/W	R/W

Additional V output control bits

CUT	VPON	POL	Description
0	0	*	Low level
		0	Negative polarity (Figure 28.46)
	1	1	Positive polarity (Figure 28.45)
1	*	0	Immediate level (high-impedance when Hi-Z bit = 1)
		1	High level

Legend: \* Don't care.

High impedance bit

0	3-level output from Vpulse pin
1	Vpulse pin is set as 3-state (H/L/Hi-Z) pin

OSCH mask bit

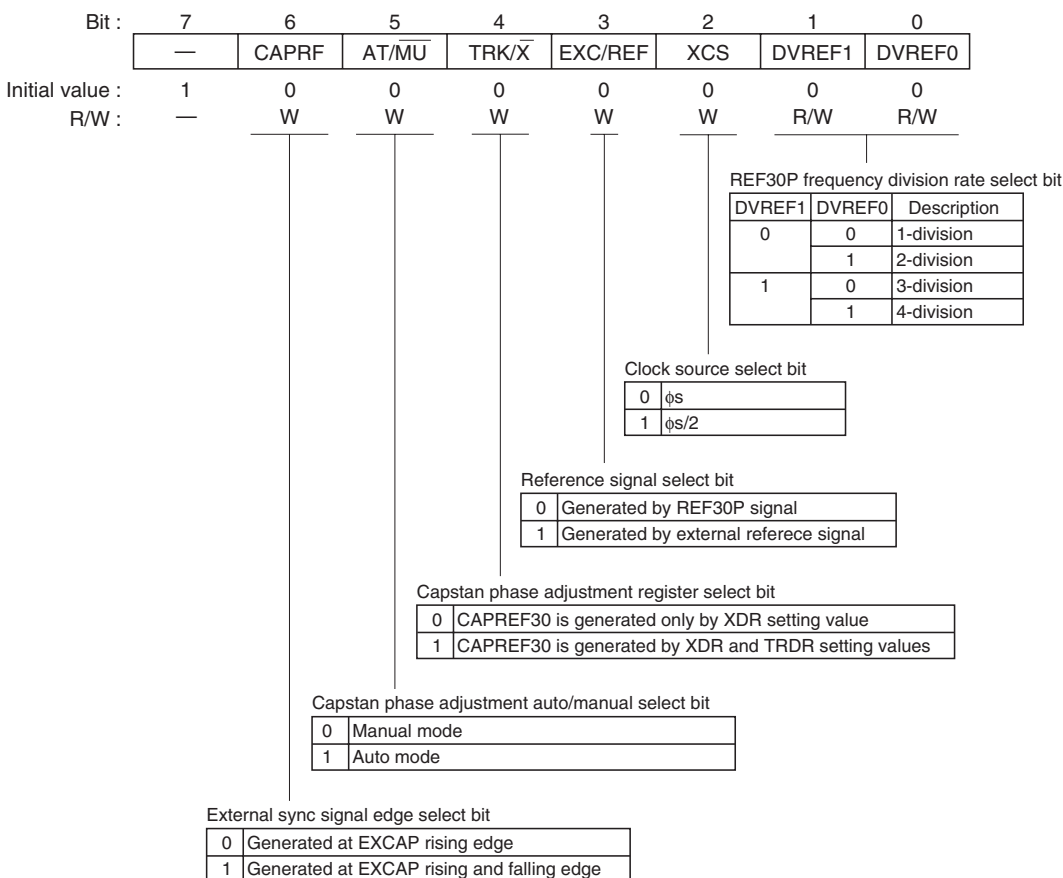
0	OSCH added
1	OSCH not added

**H'D070: X-Value Data Register XDR: X-Value, TRK-Value**

Bit :	15	14	13	12	11	10	9	8	7	6	5	4	3	2	1	0
	—	—	—	—	XD11	XD10	XD9	XD8	XD7	XD6	XD5	XD4	XD3	XD2	XD1	XD0
Initial value :	1	1	1	1	0	0	0	0	0	0	0	0	0	0	0	0
R/W :	—	—	—	—	W	W	W	W	W	W	W	W	W	W	W	W

**H'D072: TRK-Value Data Register TRDR: X-Value, TRK-Value**

Bit :	15	14	13	12	11	10	9	8	7	6	5	4	3	2	1	0
	—	—	—	—	TRD11	TRD10	TRD9	TRD8	TRD7	TRD6	TRD5	TRD4	TRD3	TRD2	TRD1	TRD0
Initial value :	1	1	1	1	0	0	0	0	0	0	0	0	0	0	0	0
R/W :	—	—	—	—	W	W	W	W	W	W	W	W	W	W	W	W

**H'D074: X-Value/TRK-Value Control Register****XTCR: X-Value, TRK-Value Adjustment Circuit****H'D078: Drum 12-Bit PWM Data Register DPWDR: Drum 12-Bit PWM**

Bit :	15	14	13	12	11	10	9	8	7	6	5	4	3	2	1	0
	—	—	—	—	DPWDR11	DPWDR10	DPWDR9	DPWDR8	DPWDR7	DPWDR6	DPWDR5	DPWDR4	DPWDR3	DPWDR2	DPWDR1	DPWDR0
Initial value :	1	1	1	1	0	0	0	0	0	0	0	0	0	0	0	0
R/W :	—	—	—	—	R/W	R/W	R/W	R/W	R/W	R/W	R/W	R/W	R/W	R/W	R/W	R/W

**H'D07A: Drum 12-Bit PWM Control Register DPWCR: Drum 12-Bit PWM**

Bit :	7	6	5	4	3	2	1	0
	DPOL	DDC	DHiZ	DH/L	DSF/DF	DCK2	DCK1	DCK0
Initial value :	0	1	0	0	0	0	1	0
R/W :	W	W	W	W	W	W	W	W

Carrier frequency select bits

CK2	CK1	CK0	Carrier frequency select bits
0	0	0	$\phi/2$
		1	$\phi/4$
	1	0	$\phi/8$
		1	$\phi/16$
1	0	0	$\phi/32$
		1	$\phi/64$
	1	0	$\phi/128$
		1	(Do not set)

Output data select bit

0	Modulate error data from digital filter circuit
1	Modulate data written in data register

Note: When PWMs output data from the digital filter circuit, the data consisting of the speed and phase filtering results are modulated by PWMs and output from the CAPPWM and DRMPWM pins. However, it is possible to output only drum phase filter results from CAPPWM pin and only capstan phase filter result from DRMPWM pin, by DFUCR settings of the digital filter circuit. See the section explaining the digital filter computation circuit.

Fixed output bit, PWM pin output bit

DC	Hi-Z	H/L	Fixed output bit, PWM pin output bit
1	0	0	Low level output from PWM pin
		1	High level output from PWM pin
	1	*	High impedance from PWM pin
0	*	*	PWM modulated signal output

Legend: \* Don't care.

Polarity switchover bit

0	Positive polarity
1	Negative polarity output

**H'D07B: Capstan 12-Bit PWM Control Register CPWCR: Capstan 12-Bit PWM**

Bit :	7	6	5	4	3	2	1	0
	CPOL	CDC	CHiZ	CH/L	CSF/DF	CCK2	CCK1	CCK0
Initial value :	0	1	0	0	0	0	1	0
R/W :	W	W	W	W	W	W	W	W

**H'D07C: Capstan 12-Bit PWM Data Register CPWDR: Capstan 12-Bit PWM**

Bit :	15	14	13	12	11	10	9	8	7	6	5	4	3	2	1	0
	—	—	—	—	CPWDR11	CPWDR10	CPWDR9	CPWDR8	CPWDR7	CPWDR6	CPWDR5	CPWDR4	CPWDR3	CPWDR2	CPWDR1	CPWDR0
Initial value :	1	1	1	1	0	0	0	0	0	0	0	0	0	0	0	0
R/W :	—	—	—	—	R/W	R/W	R/W	R/W	R/W	R/W	R/W	R/W	R/W	R/W	R/W	R/W

**H'D080: CTL Control Register CTCR: CTL Circuit**

Bit :	7	6	5	4	3	2	1	0
	NT/PL	FSLC	FSLB	FSLA	CCS	LCTL	UNCTL	SLWM
Initial value :	0	0	1	1	0	0	0	0
R/W :	W	W	W	W	W	W	R	W

Mode select bit	
0	Normal mode
1	Slow mode

CTL undetected bit	
0	Detected
1	Undetected

Long CTL bit	
0	Clock source (CCS) operates at the setting value
1	Clock source (CCS) operates for further 8-division after operating at the setting value

Clock source select bit	
0	$\phi$ s
1	$\phi$ s/2

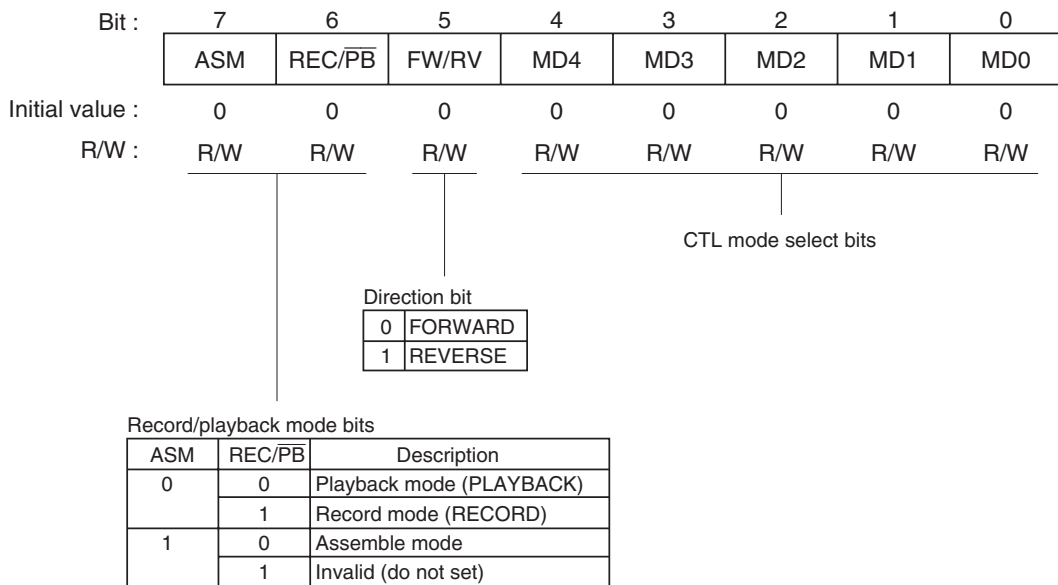
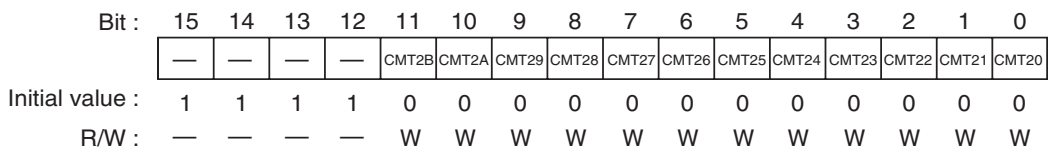
  

Operating frequency select bits			
FSLC	FSLB	FSLA	Description
0	0	0	Reserved (do not set)
		1	Reserved (do not set)
	1	0	fosc = 8 MHz
		1	fosc = 10 MHz (Initial value)
1	*	*	Reserved (do not set)

Legend: \* Don't care.

NTSC/PAL select bit	
0	NTSC mode (frame rate: 30 Hz)
1	PAL mode (frame rate: 25 Hz)

**H'D081: CTL Mode Register CTLM: CTL Circuit****H'D082: REC-CTL Duty Data Register 1 RCDR1: CTL Circuit****H'D084: REC-CTL Duty Data Register 2 RCDR2: CTL Circuit**

**H'D086: REC-CTL Duty Data Register 3 RCDR3: CTL Circuit**

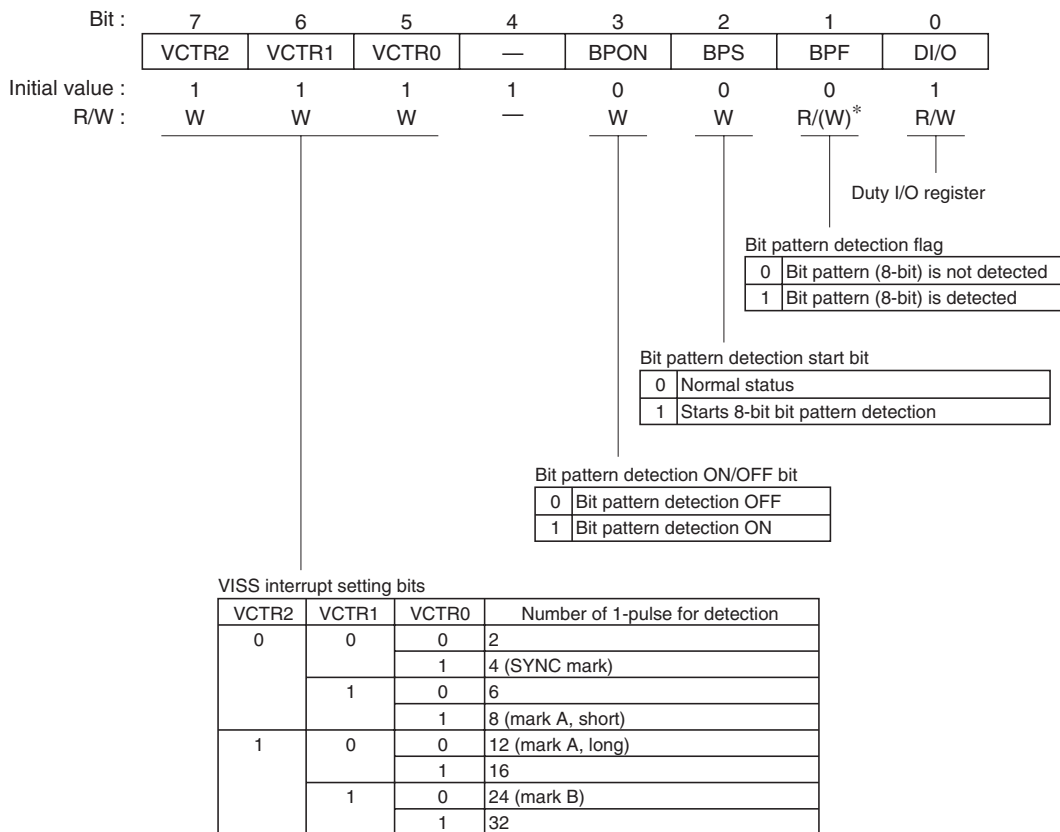
Bit :	15	14	13	12	11	10	9	8	7	6	5	4	3	2	1	0
	—	—	—	—	CMT3B	CMT3A	CMT39	CMT38	CMT37	CMT36	CMT35	CMT34	CMT33	CMT32	CMT31	CMT30
Initial value :	1	1	1	1	0	0	0	0	0	0	0	0	0	0	0	0
R/W :	—	—	—	—	W	W	W	W	W	W	W	W	W	W	W	W

**H'D088: REC-CTL Duty Data Register 4 RCDR4: CTL Circuit**

Bit :	15	14	13	12	11	10	9	8	7	6	5	4	3	2	1	0
	—	—	—	—	CMT4B	CMT4A	CMT49	CMT48	CMT47	CMT46	CMT45	CMT44	CMT43	CMT42	CMT41	CMT40
Initial value :	1	1	1	1	0	0	0	0	0	0	0	0	0	0	0	0
R/W :	—	—	—	—	W	W	W	W	W	W	W	W	W	W	W	W

**H'D08A: REC-CTL Duty Data Register 5 RCDR5: CTL Circuit**

Bit :	15	14	13	12	11	10	9	8	7	6	5	4	3	2	1	0
	—	—	—	—	CMT5B	CMT5A	CMT59	CMT58	CMT57	CMT56	CMT55	CMT54	CMT53	CMT52	CMT51	CMT50
Initial value :	1	1	1	1	0	0	0	0	0	0	0	0	0	0	0	0
R/W :	—	—	—	—	W	W	W	W	W	W	W	W	W	W	W	W

**H'D08C: Duty I/O Register DI/O: CTL Circuit**

Note: \* Only 0 can be written.

**H'D08D: Bit Pattern Register BTPR: CTL Circuit**

Bit :	7	6	5	4	3	2	1	0
	LSP7	LSP6	LSP5	LSP4	LSP3	LSP2	LSP1	LSP0
Initial value :	1	1	1	1	1	1	1	1
R/W :	R*/W	R*/W	R*/W	R*/W	R*/W	R*/W	R*/W	R*/W

Note: \* Writes are disabled during bit pattern detection.

**H'D090: Reference Frequency Register 1 RFD: Reference Signal Generator**

Bit :	15	14	13	12	11	10	9	8	7	6	5	4	3	2	1	0
	REF15	REF14	REF13	REF12	REF11	REF10	REF9	REF8	REF7	REF6	REF5	REF4	REF3	REF2	REF1	REF0
Initial value :	1	1	1	1	1	1	1	1	1	1	1	1	1	1	1	1
R/W :	W	W	W	W	W	W	W	W	W	W	W	W	W	W	W	W

**H'D092: Reference Frequency Register 2 CRF: Reference Signal Generator**

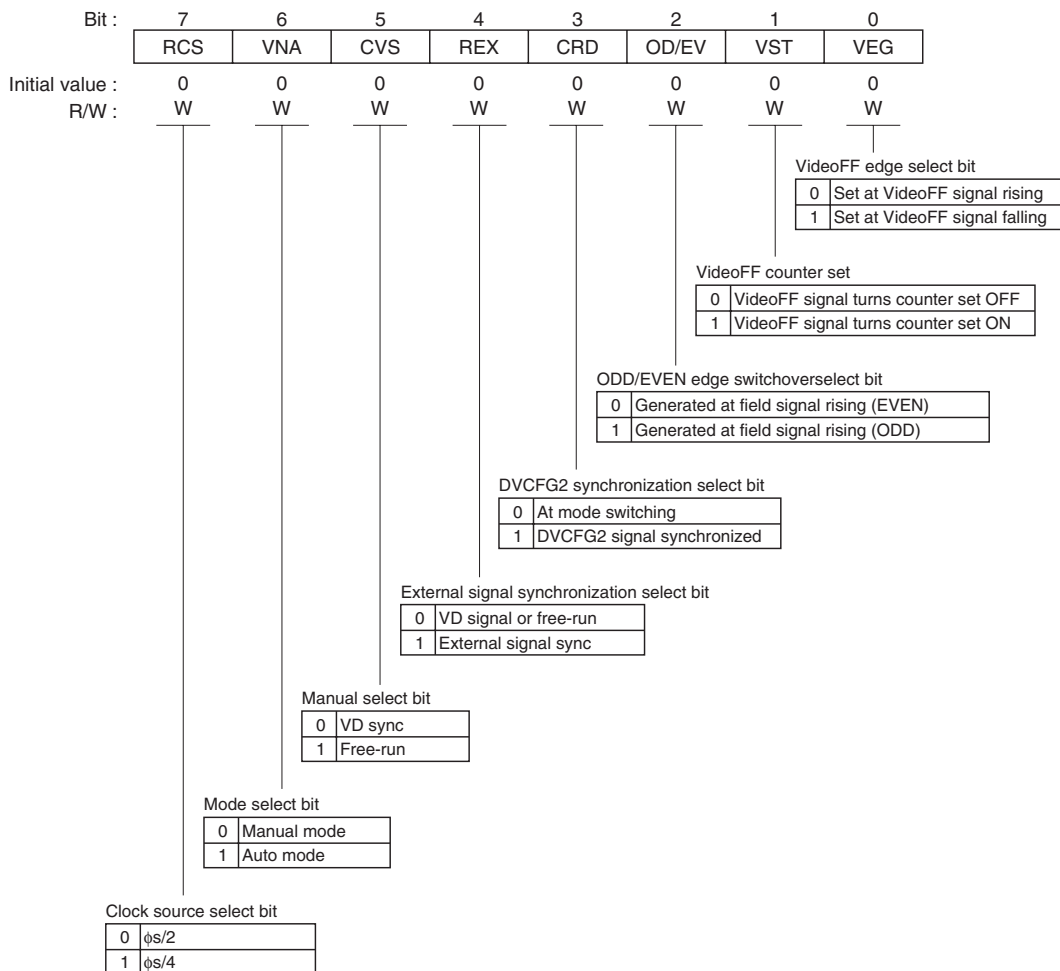
Bit :	15	14	13	12	11	10	9	8	7	6	5	4	3	2	1	0
	CRF15	CRF14	CRF13	CRF12	CRF11	CRF10	CRF9	CRF8	CRF7	CRF6	CRF5	CRF4	CRF3	CRF2	CRF1	CRF0
Initial value :	1	1	1	1	1	1	1	1	1	1	1	1	1	1	1	1
R/W :	W	W	W	W	W	W	W	W	W	W	W	W	W	W	W	W

**H'D094: REF30 Counter Register RFC: Reference Signal Generator**

Bit :	15	14	13	12	11	10	9	8	7	6	5	4	3	2	1	0
	RFC15	RFC14	RFC13	RFC12	RFC11	RFC10	RFC9	RFC8	RFC7	RFC6	RFC5	RFC4	RFC3	RFC2	RFC1	RFC0
Initial value :	0	0	0	0	0	0	0	0	0	0	0	0	0	0	0	0
R/W :	R/W	R/W	R/W	R/W	R/W	R/W	R/W	R/W	R/W	R/W	R/W	R/W	R/W	R/W	R/W	R/W



## H'D096: Reference Frequency Mode Register RFM: Reference Signal Generator



**H'D097: Reference Frequency Mode Register 2 RFM2: Reference Signal Generator**

Bit :	7	6	5	4	3	2	1	0
	(TBC)*	—	—	—	—	—	—	FDS
Initial value :	1	1	1	1	1	1	1	0
R/W :	(R/W)*	—	—	—	—	—	—	R/W

TBC select bit	
0	Reference signal is generated with VD
1	Reference signal is generated in free-run

Field select bit	
0	Generated by selected ODD or EVEN VD signal
1	Generated by VD signal immediately after mode transition

Note: \* The TBC bit is readable/writable only in the H8S/2194C Group. This bit cannot be modified in the H8S/2194 Group, and the reference signal is therefore generated in free-run.

**H'D098: DVCTL Control Register CTVC: Frequency Divider**

Bit :	7	6	5	4	3	2	1	0
	CEX	CEG	—	—	—	CFG	HSW	CTL
Initial value :	0	0	1	1	1	*	*	*
R/W :	W	W	—	—	—	R	R	R

External sync signal edge select bit	
0	Rising edge
1	Falling edge

DVCTL signal generation select bit	
0	Generated by PB-CTL signal
1	Generated by external input signal

CFG flag	
0	CFG level is low
1	CFG level is high

HSW flag	
0	HSW level is low
1	HSW level is high

CTL flag	
0	REC or PB-CTL level is low
1	REC or PB-CTL level is high

Note: \* Undetermined

**H'D099: CTL Frequency Division Register CTLR: Frequency Divider**

Bit :	7	6	5	4	3	2	1	0
	CTL7	CTL6	CTL5	CTL4	CTL3	CTL2	CTL1	CTL0
Initial value :	0	0	0	0	0	0	0	0
R/W :	W	W	W	W	W	W	W	W

**H'D09A: DVCFG Control Register CDVC: Frequency Divider**

Bit :	7	6	5	4	3	2	1	0
	MCGin	—	CMK	CMN	DVTRG	CRF	CPS1	CPS0
Initial value :	0	1	1	0	0	0	0	0
R/W :	R/W*	—	R	W	W	W	W	W

CPS1	CPS0	Description
0	0	$\phi$ s/1024
	1	$\phi$ s/512
1	0	$\phi$ s/256
	1	$\phi$ s/128

0	Execute frequency division operation at CFG rising edge
1	Execute frequency division operation at CFG rising and falling edges

0	PB (ASM)-to-REC transition timing sync ON
1	PB (ASM)-to-REC transition timing sync OFF

0	Capstan mask timing function ON
1	Capstan mask timing function OFF

0	Mask is released by capstan mask timer
1	Mask is set by capstan mask timer

0	CFG normal operation
1	DVCFG is detected while mask is set (race detection)

Note: \* Only 0 can be written

**H'D09B: CFG Frequency Division Register 1 CDIVR1: Frequency Divider**

Bit :	7	6	5	4	3	2	1	0
	—	CDV16	CDV15	CDV14	CDV13	CDV12	CDV11	CDV10
Initial value :	1	0	0	0	0	0	0	0
R/W :	—	W	W	W	W	W	W	W

**H'D09C: CFG Frequency Division Register 2 CDIVR2: Frequency Divider**

Bit :	7	6	5	4	3	2	1	0
	—	CDV26	CDV25	CDV24	CDV23	CDV22	CDV21	CDV20
Initial value :	1	0	0	0	0	0	0	0
R/W :	—	W	W	W	W	W	W	W

**H'D09D: DVCFG Mask Interval Register CTMR: Frequency Divider**

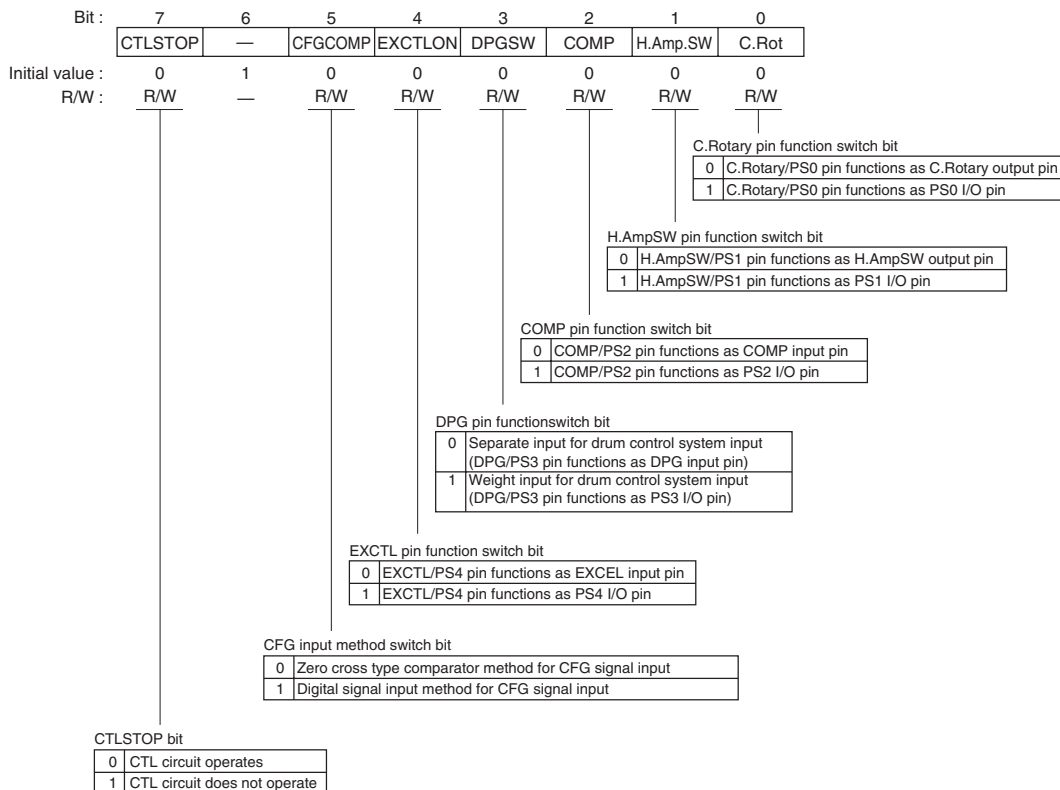
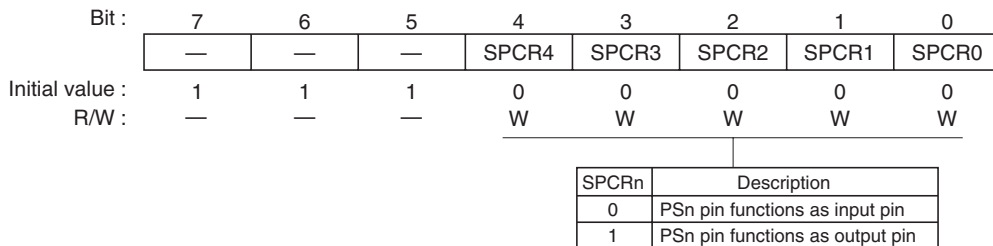
Bit :	7	6	5	4	3	2	1	0
	—	—	CPM5	CPM4	CPM3	CPM2	CPM1	CPM0
Initial value :	1	1	1	1	1	1	1	1
R/W :	—	—	W	W	W	W	W	W

**H'D09E: FG Control Register FGCR: Frequency Divider**

Bit :	7	6	5	4	3	2	1	0
	—	—	—	—	—	—	—	DRF
Initial value :	1	1	1	1	1	1	1	0
R/W :	—	—	—	—	—	—	—	W

DFG edge select bit

0	NCDFG signal rising edge is selected
1	NCDFG signal falling edge is selected

**H'D0A0: Servo Port Mode Register SPMR: Servo Port****H'D0A1: Servo Control Register SPCR: Servo Port**

**H'D0A2: Servo Data Register SPDR: Servo Port Controller**

Bit :	7	6	5	4	3	2	1	0
	—	—	—	SPDR4	SPDR3	SPDR2	SPDR1	SPDR0
Initial value :	1	1	1	0	0	0	0	0
R/W :	—	—	—	R/W	R/W	R/W	R/W	R/W

**H'D0A3: Servo Monitor Control Register SVMCR: Servo Port**

Bit :	7	6	5	4	3	2	1	0
	—	—	SVMCR5	SVMCR4	SVMCR3	SVMCR2	SVMCR1	SVMCR0
Initial value :	1	1	0	0	0	0	0	0
R/W :	—	—	R/W	R/W	R/W	R/W	R/W	R/W

SVMCR2	SVMCR1	SVMCR0	Description
0	0	0	REF30 signal is output from SV1 output pin
		1	CAPREF30 signal is output from SV1 output pin
	1	0	CREF signal is output from SV1 output pin
		1	CTLMONI signal is output from SV1 output pin
1	0	0	DVCFG signal is output from SV1 output pin
		1	CFG signal is output from SV1 output pin
	1	0	DFG signal is output from SV1 output pin
		1	DPG signal is output from SV1 output pin

SVMCR5	SVMCR4	SVMCR3	Description
0	0	0	REF30 signal is output from SV2 output pin
		1	CAPREF30 signal is output from SV2 output pin
	1	0	CREF signal is output from SV2 output pin
		1	CTLMONI signal is output from SV2 output pin
1	0	0	DVCFG signal is output from SV2 output pin
		1	CFG signal is output from SV2 output pin
	1	0	DFG signal is output from SV2 output pin
		1	DPG signal is output from SV2 output pin

**H'D0A4: CTL Gain Control Register CTLGR: Servo Port**

Bit :	7	6	5	4	3	2	1	0
	—	—	CTLE/ $\bar{A}$	CTLFB	CTLGR3	CTLGR2	CTLGR1	CTLGR0
Initial value :	1	1	0	0	0	0	0	0
R/W :	—	—	R/W	R/W	R/W	R/W	R/W	R/W

CTL amp gain setting bit

CTLGR3	CTLGR2	CTLGR1	CTLGR0	CTL output gain
0	0	0	0	34.0 dB
			1	36.5 dB
		1	0	39.0 dB
	1	0	1	41.5 dB
			0	44.0 dB
		1	0	46.5 dB
1	0	0	1	49.0 dB
			0	51.5 dB
		1	0	54.0 dB
	1	0	1	56.5 dB
			0	59.0 dB
		1	0	61.5 dB
1	0	0	64.0 dB*	
		1	66.5 dB*	
	1	0	69.0 dB*	
			1	71.5 dB*

Note: \* With a setting of 64.0dB or more, the CTLAMP is in a very sensitive status. When configuring the set board, be concerned about countermeasure against noise around the control head signal input port. Also, thoroughly set the filter between the CTLAMP and CTLSMT.

CTL amp feedback SW bit

0	CTLFB SW is OFF
1	CTLFB SW is ON

CTL select bit

0	AMP output
1	EXCTL

**H'D0B0: Vertical Sync Signal Threshold Value Register VTR: Sync Detector (Servo)**

Bit :	7	6	5	4	3	2	1	0
	—	—	VTR5	VTR4	VTR3	VTR2	VTR1	VTR0
Initial value :	1	1	0	0	0	0	0	0
R/W :	—	—	W	W	W	W	W	W

**H'D0B1: Horizontal Sync Signal Threshold Value Register HTR: Sync Detector (Servo)**

Bit :	7	6	5	4	3	2	1	0
	—	—	—	—	HTR3	HTR2	HTR1	HTR0
Initial value :	1	1	1	1	0	0	0	0
R/W :	—	—	—	—	W	W	W	W

**H'D0B2: H Pulse Adjustment Start Time Setting Register HRTR: Sync Detector (Servo)**

Bit :	7	6	5	4	3	2	1	0
	HRTR7	HRTR6	HRTR5	HRTR4	HRTR3	HRTR2	HRTR1	HRTR0
Initial value :	0	0	0	0	0	0	0	0
R/W :	W	W	W	W	W	W	W	W

**H'D0B3: H Pulse Width Setting Register HPWR: Sync Detector (Servo)**

Bit :	7	6	5	4	3	2	1	0
	—	—	—	—	HPWR3	HPWR2	HPWR1	HPWR0
Initial value :	1	1	1	1	0	0	0	0
R/W :	—	—	—	—	W	W	W	W

**H'D0B4: Noise Detection Window Setting Register NWR: Sync Detector (Servo)**

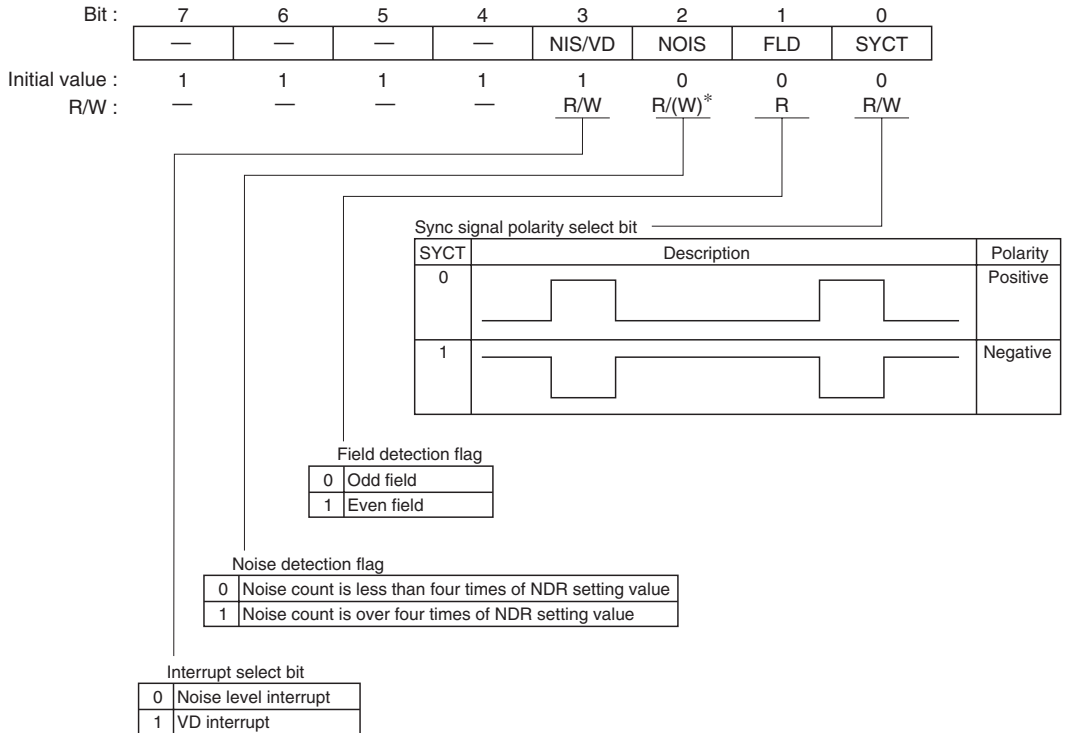
Bit :	7	6	5	4	3	2	1	0
	—	—	NWR5	NWR4	NWR3	NWR2	NWR1	NWR0
Initial value :	1	1	0	0	0	0	0	0
R/W :	—	—	W	W	W	W	W	W

**H'D0B5: Noise Detection Register NDR: Sync Detector (Servo)**

Bit :	7	6	5	4	3	2	1	0
	NDR7	NDR6	NDR5	NDR4	NDR3	NDR2	NDR1	NDR0
Initial value :	0	0	0	0	0	0	0	0
R/W :	W	W	W	W	W	W	W	W



## H'D0B6: Sync Signal Control Register SYNCR: Sync Detector (Servo)



Note: \* Only 0 can be written.

## H'D0B8: Servo Interrupt Enable Register 1 SIENR1: Servo Interrupt

Bit :	7	6	5	4	3	2	1	0
	IEDRM3	IEDRM2	IEDRM1	IECAP3	IECAP2	IECAP1	IEHSW2	IEHSW1
Initial value :	0	0	0	0	0	0	0	0
R/W :	R/W	R/W	R/W	R/W	R/W	R/W	R/W	R/W

0	Interrupt request is disabled by IRRHWSW1
1	Interrupt request is enabled by IRRHWSW1

HSW timing generator (OVW, match, STRIG) interrupt enable bit

0	Interrupt request is disabled by IRRHSW2
1	Interrupt request is enabled by IRRHSW2

HSW timing generation (counter clear, capture) interrupt enable bit

0	Interrupt request is disabled by IRRCAP1
1	Interrupt request is enabled by IRRCAP1

Capstan speed error detection (OVF, latch) interrupt enable bit

0	Interrupt request is disabled by IRRCAP2
1	Interrupt request is enabled by IRRCAP2

Capstan speed error detection (lock detection) interrupt enable bit

0	Interrupt request is disabled by IRRCAP3
1	Interrupt request is enabled by IRRCAP3

Capstan phase error detection interrupt enable bit

0	Interrupt request is disabled by IRRDRM1
1	Interrupt request is enabled by IRRDRM1

Drum speed error detection (OVF, latch) interrupt enable bit

0	Interrupt request is disabled by IRRDRM2
1	Interrupt request is enabled by IRRDRM2

Drum speed error detection (lock detection) interrupt enable bit

0	Interrupt request is disabled by IRRDRM3
1	Interrupt request is enabled by IRRDRM3

Drum phase error detection interrupt enable bit

**H'D0B9: Servo Interrupt Enable Register 2 SIENR2: Servo Interrupt**

Bit :	7	6	5	4	3	2	1	0
	—	—	—	—	—	—	IESNC	IECTL
Initial value :	1	1	1	1	1	1	0	0
R/W :	—	—	—	—	—	—	R/W	R/W

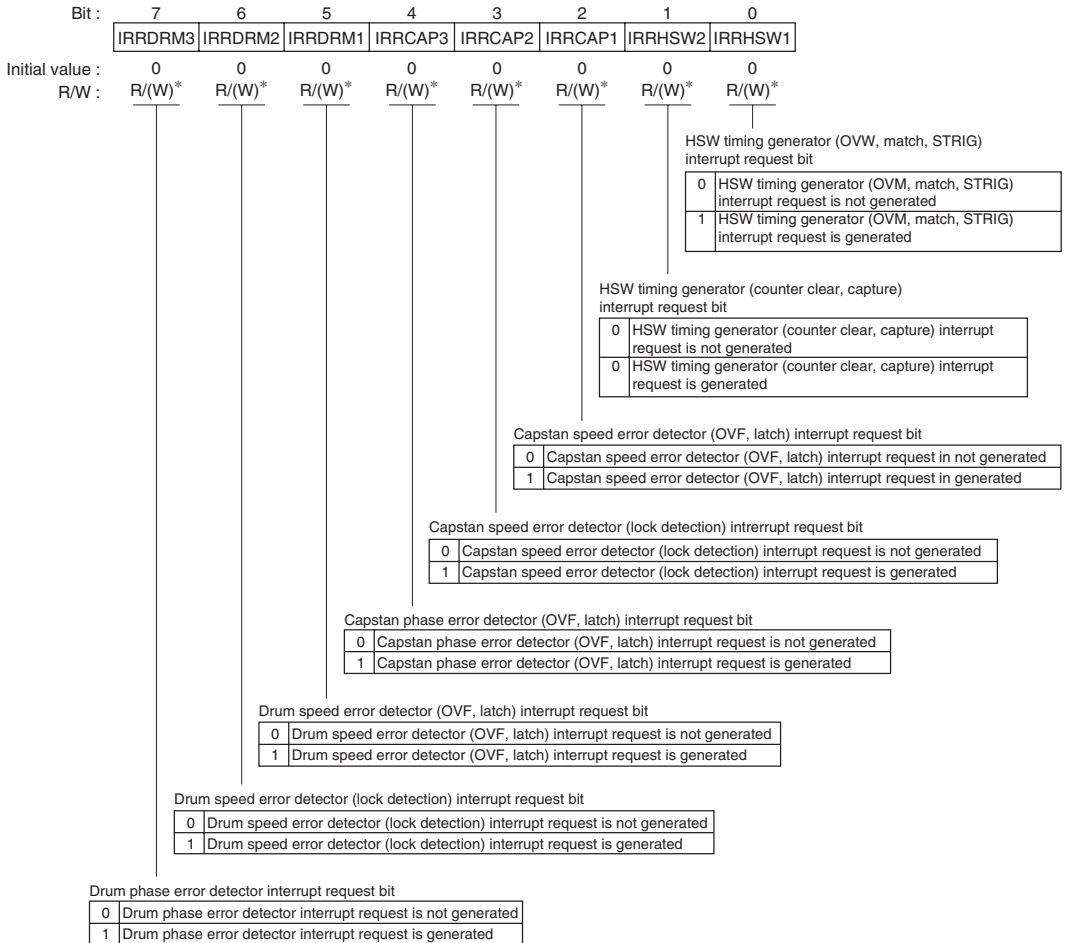
  

CTL interrupt enable bit	
0	Interrupt request is disabled by IRRCTL
1	Interrupt request is enabled by IRRCTL

Vertical sync signal interrupt enable bit	
0	Interrupt (vertical sync signal interrupt) request is disabled by IRRSNC
1	Interrupt (vertical sync signal interrupt) request is enabled by IRRSNC

## H'D0BA: Servo Interrupt Request Register 1 SIRQR1: Servo Interrupt



**H'D0BB: Servo Interrupt Request Register 2 SIRQR2: Servo Interrupt**

Bit :	7	6	5	4	3	2	1	0
	—	—	—	—	—	—	IRRSNC	IRRCTL
Initial value :	1	1	1	1	1	1	0	0
R/W :	—	—	—	—	—	—	R/(W)*	R/(W)*

CTL interrupt request bit	
0	CTL interrupt request is not generated
1	CTL interrupt request is generated

Vertical sync signal interrupt request bit	
0	Sync signal detector (VD, noise) interrupt request is not generated
1	Sync signal detector (VD, noise) interrupt request is generated

Note: \* Only 0 can be written to clear the flag.

**H'D0E0: Start Address Register STAR: 32-Byte Buffer SCI2**

Bit :	7	6	5	4	3	2	1	0
	—	—	—	STA4	STA3	STA2	STA1	STA0
Initial value :	1	1	1	0	0	0	0	0
R/W :	—	—	—	R/W	R/W	R/W	R/W	R/W

**H'D0E1: End Address Register EDAR: 32-Byte Buffer SCI2**

Bit :	7	6	5	4	3	2	1	0
	—	—	—	EDA4	EDA3	EDA2	EDA1	EDA0
Initial value :	1	1	1	0	0	0	0	0
R/W :	—	—	—	R/W	R/W	R/W	R/W	R/W

### H'D0E2: Serial Control Register 2 SCR2: 32-Byte Buffer SCI2

Bit :	7	6	5	4	3	2	1	0
	TEIE	ABTIE	—	GAP1	GAP0	CKS2	CKS1	CKS0
Initial value :	0	0	1	0	0	0	0	0
R/W :	R/W	R/W	—	R/W	R/W	R/W	R/W	R/W

Transfer clock select bits

CKS2	CKS1	CKS0	SCK2 pin	Clock source	Prescaler frequency division rate	Transfer clock frequency	
						$\phi = 10\text{ MHz}$	$\phi = 5\text{ MHz}$
0	0	0	SCK2 output	Sprescaler S	$\phi/256$	25.6 $\mu\text{s}$	51.2 $\mu\text{s}$
0	0	1			$\phi/64$	6.4 $\mu\text{s}$	12.8 $\mu\text{s}$
0	1	0			$\phi/32$	3.2 $\mu\text{s}$	6.4 $\mu\text{s}$
0	1	1			$\phi/16$	1.6 $\mu\text{s}$	3.2 $\mu\text{s}$
1	0	0			$\phi/8$	0.8 $\mu\text{s}$	1.6 $\mu\text{s}$
1	0	1			$\phi/4$	0.4 $\mu\text{s}$	0.8 $\mu\text{s}$
1	1	0	SCK2 input	External clock	$\phi/2$	—	0.4 $\mu\text{s}$
1	1	1			—	—	—

Transfer data interval select bits

GAP1	GAP0	Transfer data interval
0	0	No interval
0	1	8-clock interval
1	0	24-clock interval
1	1	56-clock interval

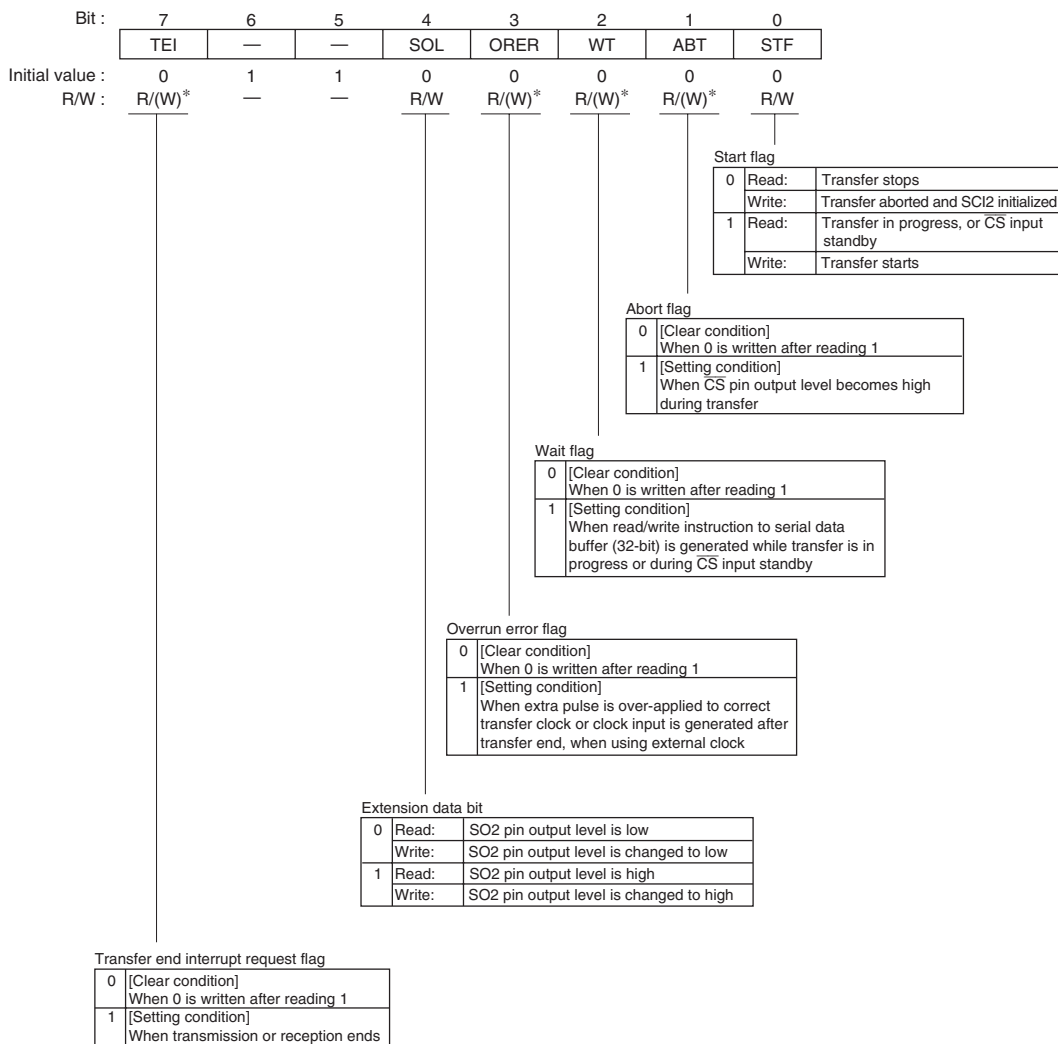
Transfer interrupt enable bit

0	Transfer interrupt request is disabled
1	Transfer interrupt request is enabled

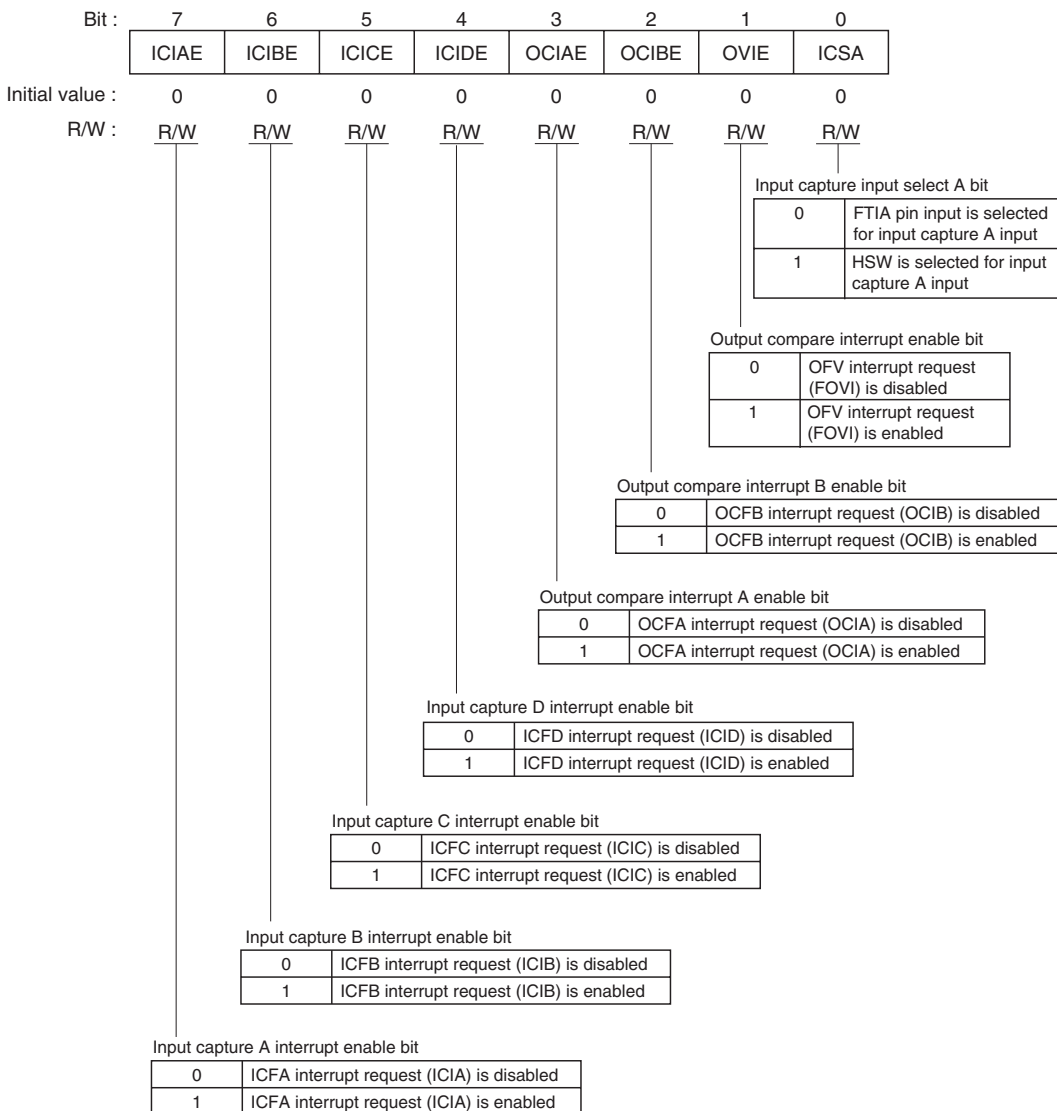
Transfer end interrupt enable bit

0	Transfer-end interrupt request is disabled
1	Transfer-end interrupt request is enabled

## H'D0E3: Serial Control Status Register 2 SCSR2: 32-Byte Buffer SCI2

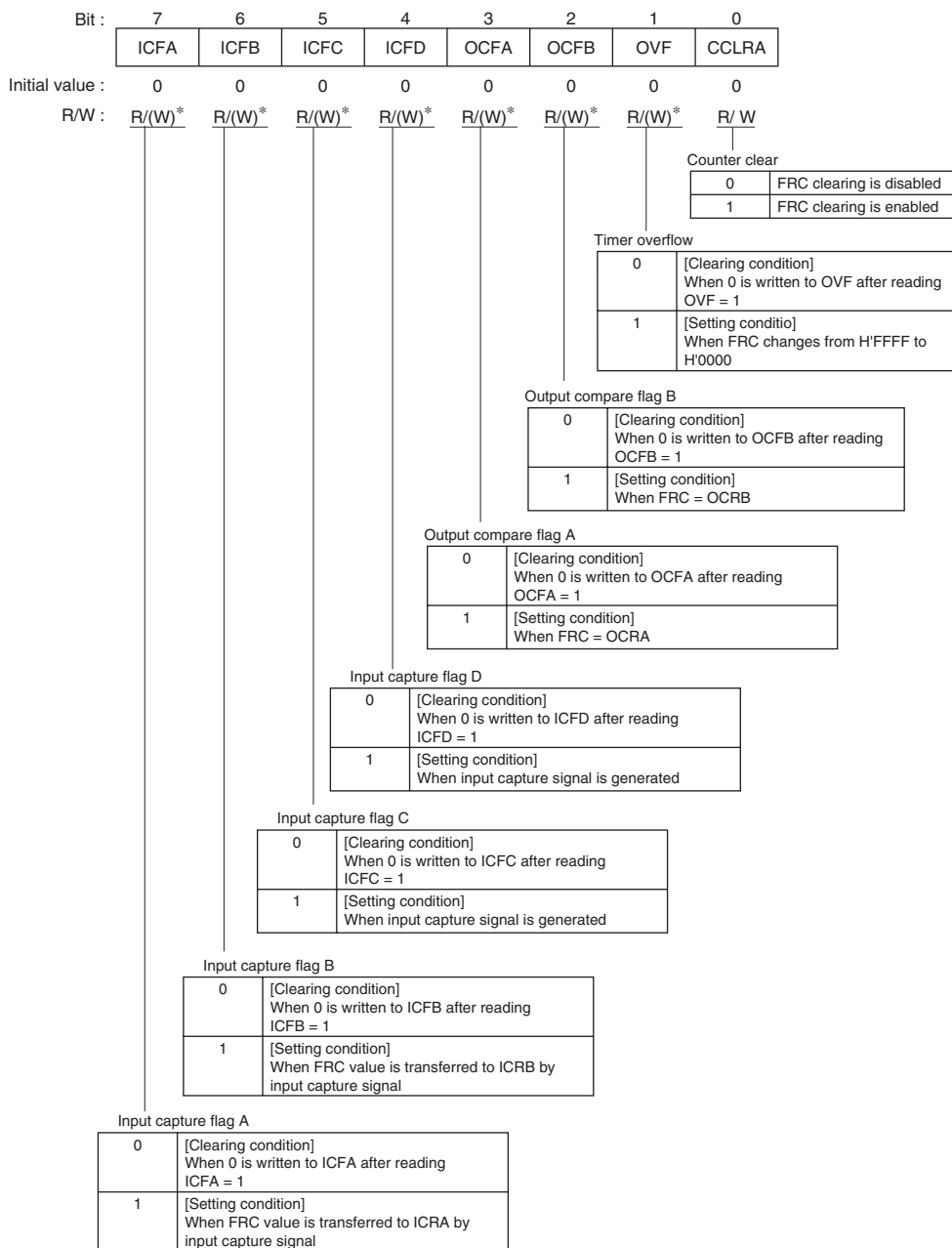


Note: \* Only 0 can be written to clear the flag.

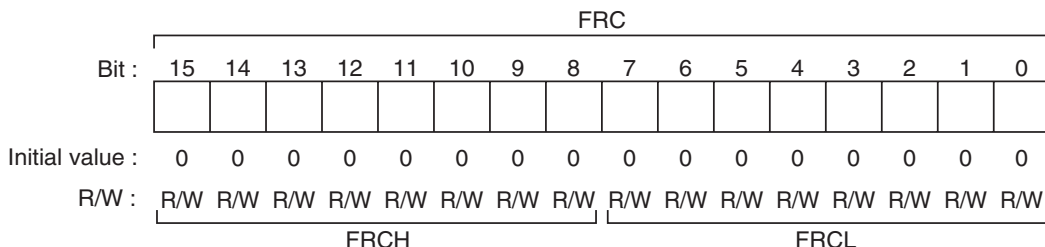
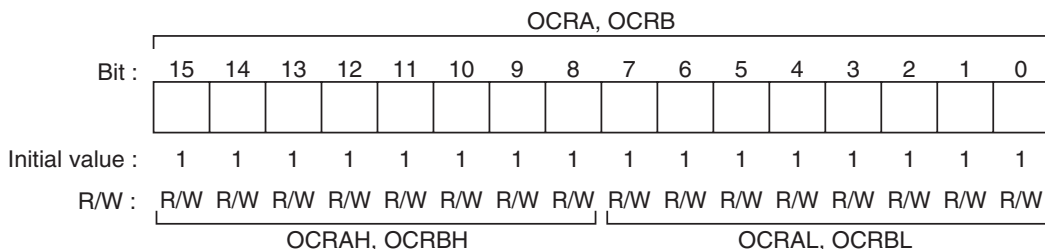
**H'D100: Timer Interrupt Enable Register ITER: Timer X1**



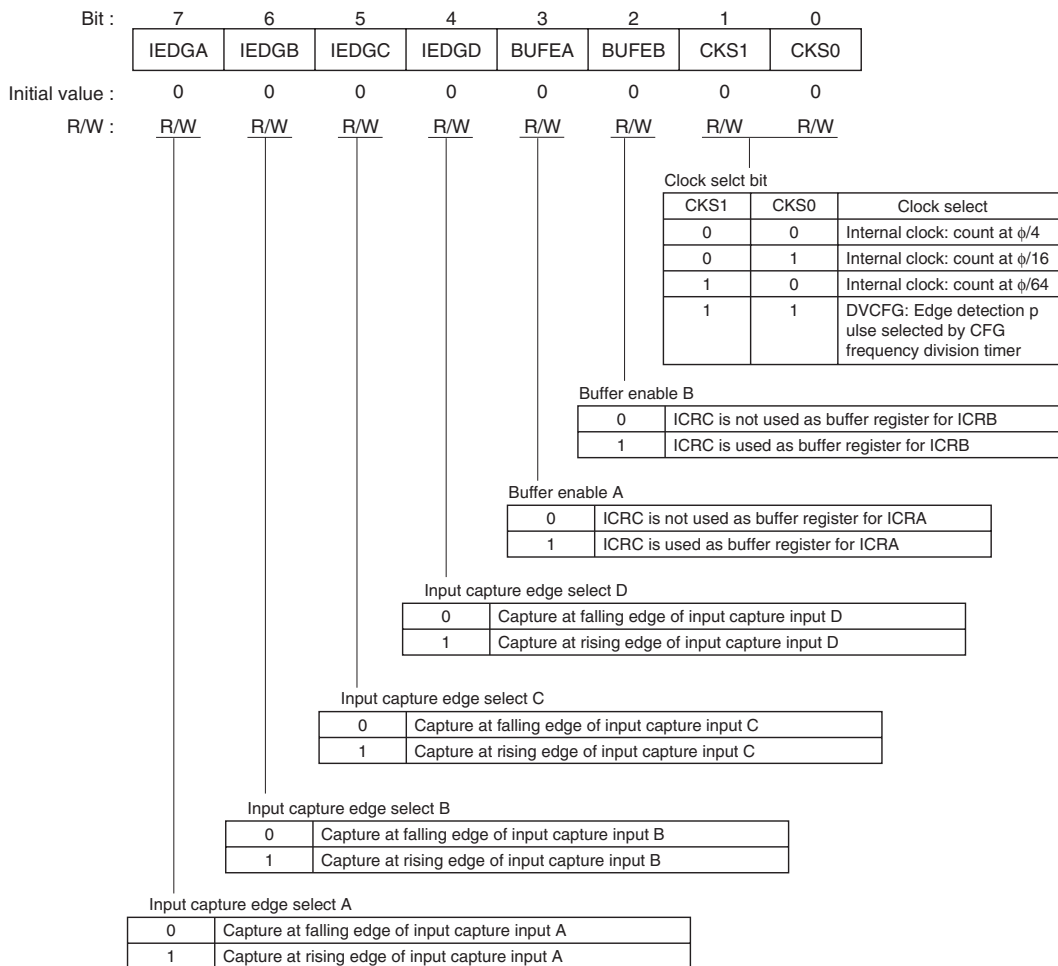
## H'D101: Timer Control/Status Register X TCSRX: Timer X1

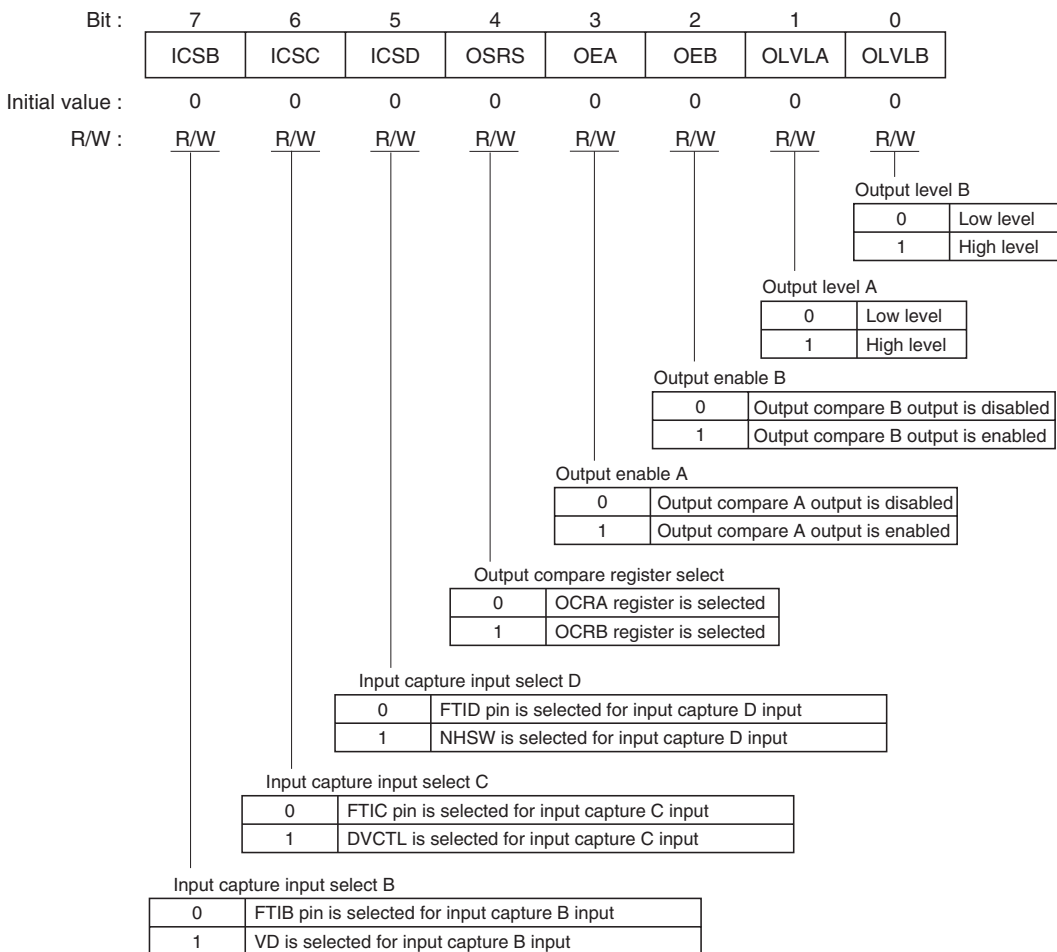


Note: \* Only 0 can be written to bits 7 to 1 to clear the flags.

**H'D102: Free Running Counter H FRCH: Timer X1****H'D103: Free Running Counter L FRCL: Timer X1****H'D104: Output Compare Register AH, BH OCRAH, OCRBH: Timer X1****H'D105: Output Compare Register AL, BL OCRAL, OCRBL: Timer X1**

## H'D106: Timer Control Register X TCRX: Timer X1



**H'D107: Timer Output Compare Control Register TOCR: Timer X1**

**H'D108: Input Capture Register AH ICRAH: Timer X1**

**H'D109: Input Capture Register AL ICRAL: Timer X1**

**H'D10A: Input Capture Register BH ICRBH: Timer X1**

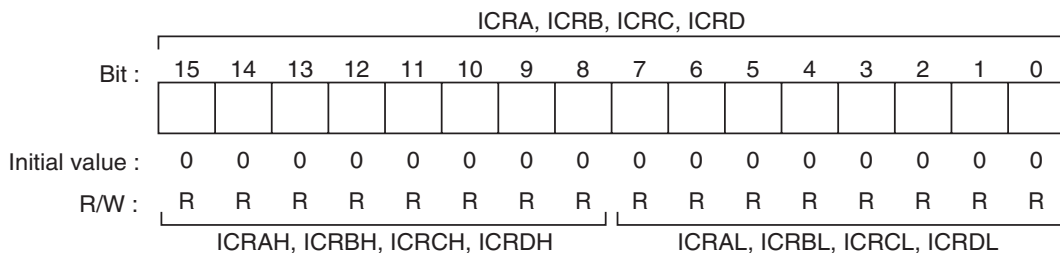
**H'D10B: Input Capture Register BL ICRBL: Timer X1**

**H'D10C: Input Capture Register CH ICRCH: Timer X1**

**H'D10D: Input Capture Register CL ICRCL: Timer X1**

**H'D10E: Input Capture Register DH ICRDH: Timer X1**

**H'D10F: Input Capture Register DL ICRDL: Timer X1**



**H'D110: Timer Mode Register B TMB: Timer B**

Bit :	7	6	5	4	3	2	1	0
	TMB17	TMBIF	TMBIE	—	—	TMB12	TMB11	TMB10
Initial value :	0	0	0	1	1	0	0	0
R/W :	R/W	R/(W)*	R/W	—	—	R/W	R/W	R/W

Clock select bit

TMB12	TMB11	TMB10	Clock select
0	0	0	Internal clock: Count at $\phi/16384$
0	0	1	Internal clock: Count at $\phi/4096$
0	1	0	Internal clock: Count at $\phi/1024$
0	1	1	Internal clock: Count at $\phi/512$
1	0	0	Internal clock: Count at $\phi/128$
1	0	1	Internal clock: Count at $\phi/32$
1	1	0	Internal clock: Count at $\phi/8$
1	1	1	Count at rising/falling edge of external event (TMBI)*

Note: \* External event edge selection is set at PMR51 in port mode register 5 (PMR5).

See section 13.2.4, Port Register 5 (PMR5).

Timer B interrupt enable bit

0	Timer B interrupt request is disabled
1	Timer B interrupt request is enabled

Timer B interrupt request flag

0	[Clearing condition] When 0 is written after reading 1
1	[Setting condition] When TCB overflows

Auto reload function select bit

0	Interval function is selected
1	Auto reload function is selected

Note: \* Only 0 can be written to clear the flag.

**H'D111: Timer Counter B TCB: Timer B**

Bit :	7	6	5	4	3	2	1	0
	TCB17	TCB16	TCB15	TCB14	TCB13	TCB12	TCB11	TCB10
Initial value :	0	0	0	0	0	0	0	0
R/W :	R	R	R	R	R	R	R	R

**H'D111: Timer Load RegisterB TLB: TimerB**

Bit :	7	6	5	4	3	2	1	0
	TLB17	TLB16	TLB15	TLB14	TLB13	TLB12	TLB11	TLB10
Initial value :	0	0	0	0	0	0	0	0
R/W :	W	W	W	W	W	W	W	W

**H'D112: Timer L Mode Register LMR: Timer L**

Bit :	7	6	5	4	3	2	1	0
	LMIF	LMIE	—	—	IMR3	IMR2	IMR1	IMR0
Initial value :	0	0	1	1	0	0	0	0
R/W :	R/(W)*	R/W	—	—	R/W	R/W	R/W	R/W

Clock select bit

R2	LMR1	LMR0	Clock select
0	0	0	Count at rising edge of PB and REC-CTL
		1	Count at falling edge of PB and REC-CTL
1	1	*	Count DVCFG2
	0	*	Internal clock: Count at $\phi/128$
	1	*	Internal clock: Count at $\phi/64$

Legend: \* Don't care.

Up/down count control

0	Up count control
1	Down count control

Timer L interrupt enable bit

0	Timer L interrupt request is disabled
1	Timer L interrupt request is enabled

Timer L interrupt request flag

0	[Clearing condition] When 0 is written after reading 1
1	[Setting condition] When LTC overflow, underflow or compare match clear occurs

Note: \* Only 0 can be written to clear the flag.

**H'D113: Linear Time Counter LTC: Timer L**

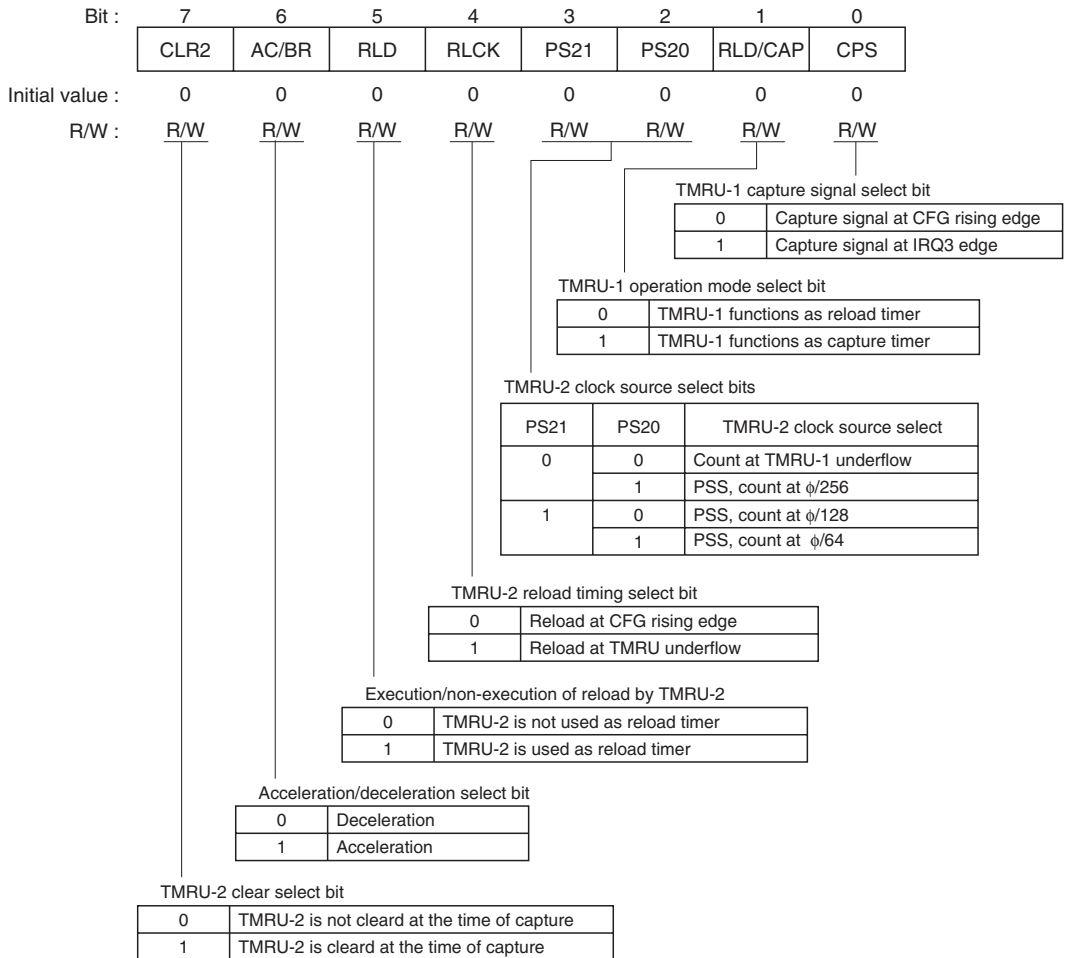
Bit :	7	6	5	4	3	2	1	0
	LTC7	LTC6	LTC5	LTC4	LTC3	LTC2	LTC1	LTC0
Initial value :	0	0	0	0	0	0	0	0
R/W :	R	R	R	R	R	R	R	R

**H'D113: Reload/Compare Match Register RCR: Timer L**

Bit :	7	6	5	4	3	2	1	0
	RCR7	RCR6	RCR5	RCR4	RCR3	RCR2	RCR1	RCR0
Initial value :	0	0	0	0	0	0	0	0
R/W :	W	W	W	W	W	W	W	W



## H'D118: Timer R Mode Register 1 TMRM1: Timer R



## H'D119: Timer R Mode Register TMRM2: Timer R

Bit :	7	6	5	4	3	2	1	0
	LAT	PS11	PS10	PS31	PS30	CP/SLM	CAPF	SLW
Initial value :	0	0	0	0	0	0	0	0
R/W :	R/W	R/W	R/W	R/W	R/W	R/W	R/(W)*	R/(W)*

Slow tracking mono-multi flag	
0	[Clearing condition] When 0 is written after reading 1
1	[Setting condition] When slow tracking mono-multi ends while CP/SLM bit = 1

Capture signal flag	
0	[Clearing condition] When 0 is written after reading 1
1	[Setting condition] When TMRU-2 capture signal is generated while CP/SLM bit = 0

Interrupt select bit	
0	Interrupt request by TMRU-2 capture signal is enabled
1	Interrupt request by slow tracking mono-multi end is enabled

TMRU-3 clock source select bits		
PS31	PS30	TMRU-3 clock source select
0	0	Count at rising edge of DVCTL from frequency divider
	1	PSS, count at $\phi/4096$
1	0	PSS, count at $\phi/2048$
	1	PSS, count at $\phi/1024$

TMRU-1 clock source select bits		
PS11	PS10	TMRU-1 clock source select
0	0	Count at CFG rising edge
	1	PSS, count at $\phi/4$
1	0	PSS, count at $\phi/256$
	1	PSS, count at $\phi/512$

TMRU-2 capture signal select bits		
LAT	CPS	TMRU-2 capture signal select
0	*	Capture at TMRU-3 underflow
1	0	Capture at CFG rising edge
	1	Capture at IRQ3 edge

Legend: \* Don't care.

Note: \* Only 0 can be written to clear the flag.

**H'D11A: Timer R Capture Register 1 TMRCP1: Time R**

Bit :	7	6	5	4	3	2	1	0
	TMRC17	TMRC16	TMRC15	TMRC14	TMRC13	TMRC12	TMRC11	TMRC10
Initial value :	1	1	1	1	1	1	1	1
R/W :	R	R	R	R	R	R	R	R

**H'D11B: Timer R Capture Register 2 TMRCP2: Time R**

Bit :	7	6	5	4	3	2	1	0
	TMRC27	TMRC26	TMRC25	TMRC24	TMRC23	TMRC22	TMRC21	TMRC20
Initial value :	1	1	1	1	1	1	1	1
R/W :	R	R	R	R	R	R	R	R

**H'D11C: Timer R Load Register 1 TMRL1: Timer R**

Bit :	7	6	5	4	3	2	1	0
	TMR17	TMR16	TMR15	TMR14	TMR13	TMR12	TMR11	TMR10
Initial value :	1	1	1	1	1	1	1	1
R/W :	W	W	W	W	W	W	W	W

**H'D11D: Timer R Load Register 2 TMRL2: Timer R**

Bit :	7	6	5	4	3	2	1	0
	TMR27	TMR26	TMR25	TMR24	TMR23	TMR22	TMR21	TMR20
Initial value :	1	1	1	1	1	1	1	1
R/W :	W	W	W	W	W	W	W	W

**H'D11E: Timer R Load Register 3 TMRL3: Timer R**

Bit :	7	6	5	4	3	2	1	0
	TMR37	TMR36	TMR35	TMR34	TMR33	TMR32	TMR31	TMR30
Initial value :	1	1	1	1	1	1	1	1
R/W :	W	W	W	W	W	W	W	W

**H'D11F: Timer R Control/Status Register TMRCS: Timer R**

Bit :	7	6	5	4	3	2	1	0
	TMRI3E	TMRI2E	TMRI1E	TMRI3	TMRI2	TMRI1	—	—
Initial value :	0	0	0	0	0	0	1	1
R/W :	R/W	R/W	R/W	R/(W)*	R/(W)*	R/(W)*	—	—

0	[Clearing condition] When 0 is written after reading 1
1	[Setting condition] When TMRU-1 underflows

0	[Clearing condition] When 0 is written after reading 1
1	[Setting condition] When TMRU-2 underflows or when capstan motor acceleration/deceleration operation ends

0	[Clearing condition] When 0 is written after reading 1
1	[Setting condition] When interrupt source selected at CP/SLM bit in TMRM2 is generated

0	TMRI1 interrupt request is disabled
1	TMRI1 interrupt request is enabled

0	TMRI2 interrupt request is disabled
1	TMRI2 interrupt request is enabled

0	TMRI3 interrupt request is disabled
1	TMRI3 interrupt request is enabled

Note: \* Only 0 can be written to clear the flag.

**H'D120: PWM Data Register L PWDRL: 14-Bit PWM**

Bit :	7	6	5	4	3	2	1	0
	PWDRL7	PWDRL6	PWDRL5	PWDRL4	PWDRL3	PWDRL2	PWDRL1	PWDRL0
Initial value :	0	0	0	0	0	0	0	0
R/W :	W	W	W	W	W	W	W	W

**H'D121: PWM Data Register U PWDRU: 14-Bit PWM**

Bit :	7	6	5	4	3	2	1	0
	—	—	PWDRU5	PWDRU4	PWDRU3	PWDRU2	PWDRU1	PWDRU0
Initial value :	1	1	0	0	0	0	0	0
R/W :	—	—	W	W	W	W	W	W

**H'D122: PWM Control Register PWCR: 14-Bit PWM**

Bit :	7	6	5	4	3	2	1	0
	—	—	—	—	—	—	—	PWCR0
Initial value :	1	1	1	1	1	1	1	0
R/W :	—	—	—	—	—	—	—	R/W

Clock select bit

0	Input clock is $\phi/2$ ( $t\phi = 2/\phi$ ) Generate PWM waveform with conversion frequency of $16384/\phi$ and minimum pulse width of $1/\phi$
1	Input clock is $\phi/4$ ( $t\phi = 4/\phi$ ) Generate PWM waveform with conversion frequency of $32768/\phi$ and minimum pulse width of $2/\phi$

Note: \*  $t\phi$ : PWM input clock frequency**H'D126: 8-Bit PWM Data Register 0 PWR0: 8-Bit PWM**

Bit :	7	6	5	4	3	2	1	0
	PW07	PW06	PW05	PW04	PW03	PW02	PW01	PW00
Initial value :	0	0	0	0	0	0	0	0
R/W :	W	W	W	W	W	W	W	W

**H'D127: 8-Bit PWM Data Register 1 PWR1: 8-Bit PWM**

Bit :	7	6	5	4	3	2	1	0
	PW17	PW16	PW15	PW14	PW13	PW12	PW11	PW10
Initial value :	0	0	0	0	0	0	0	0
R/W :	W	W	W	W	W	W	W	W

**H'D128: 8-Bit PWM Data Register 2 PWR2: 8-Bit PWM**

Bit :	7	6	5	4	3	2	1	0
	PW27	PW26	PW25	PW24	PW23	PW22	PW21	PW20
Initial value :	0	0	0	0	0	0	0	0
R/W :	W	W	W	W	W	W	W	W

**H'D129: 8-Bit PWM Data Register 3 PWR3: 8-Bit PWM**

Bit :	7	6	5	4	3	2	1	0
	PW37	PW36	PW35	PW34	PW33	PW32	PW31	PW30
Initial value :	0	0	0	0	0	0	0	0
R/W :	W	W	W	W	W	W	W	W

**H'D12A: 8-Bit PWM Control Register PW8CR: 8-Bit PWM**

Bit :	7	6	5	4	3	2	1	0
	—	—	—	—	PWC3	PWC2	PWC1	PWC0
Initial value :	1	1	1	1	0	0	0	0
R/W :	—	—	—	—	R/W	R/W	R/W	R/W

Output polarity select bits

0	Positive polarity
1	Negative polarity

Note: n = 3 to 0

**H'D12C: Input Capture Register 1 ICR1: PSU**

Bit :	7	6	5	4	3	2	1	0
	ICR17	ICR16	ICR15	ICR14	ICR13	ICR12	ICR11	ICR10
Initial value :	0	0	0	0	0	0	0	0
R/W :	R	R	R	R	R	R	R	R

## H'D12D: Prescaler Unit Control/Status Register PCSR: PSU

Bit :	7	6	5	4	3	2	1	0
	ICIF	ICIE	ICEG	NCon/off	—	DCS2	DCS1	DCS0
Initial value :	0	0	0	0	1	0	0	0
R/W :	R/(W)*	R/W	R/W	R/W	—	R/W	R/W	R/W

Frequency division clock output select bits

DCS2	DCS1	DCS0	Frequency division clock output select
0	0	0	PSS, output $\phi/32$
		1	PSS, output $\phi/16$
	1	0	PSS, output $\phi/8$
		1	PSS, output $\phi/4$
1	0	0	PSW, output $\phi W/32$
		1	PSW, output $\phi W/16$
	1	0	PSW, output $\phi W/8$
		1	PSW, output $\phi W/4$

Noise cancel ON/OFF bit

0	Noise cancel function of $\overline{IC}$ pin is disabled
1	Noise cancel function of $\overline{IC}$ pin is enabled

 $\overline{IC}$  pin edge select bit

0	Falling edge of $\overline{IC}$ pin input is detected
1	Rising edge of $\overline{IC}$ pin input is detected

Input capture interrupt enable bit

0	Interrupt request by input capture is disabled
1	Interrupt request by input capture is enabled

Input capture interrupt flag

0	[Clearing condition] When 0 is written after reading 1
1	[Setting condition] When input capture is executed at $\overline{IC}$ pin edge

Note: \* Only 0 can be written to clear the flag.

**H'D130: Software Trigger A/D Result Register H ADRH: A/D Converter****H'D131: Software Trigger A/D Result Register L ADRL: A/D Converter**

Bit :	ADRH								ADRL							
	15	14	13	12	11	10	9	8	7	6	5	4	3	2	1	0
	ADR9	ADR8	ADR7	ADR6	ADR5	ADR4	ADR3	ADR2	ADR1	ADR0	—	—	—	—	—	—
Initial value :	0	0	0	0	0	0	0	0	0	0	0	0	0	0	0	0
R/W :	R	R	R	R	R	R	R	R	R	R	—	—	—	—	—	—

**H'D132: Hardware Trigger A/D Result Register H AHRH: A/D Converter****H'D133: Hardware Trigger A/D Result Register L AHRL: A/D Converter**

Bit :	AHRH								AHRL							
	15	14	13	12	11	10	9	8	7	6	5	4	3	2	1	0
	AHR9	AHR8	AHR7	AHR6	AHR5	AHR4	AHR3	AHR2	AHR1	AHR0	—	—	—	—	—	—
Initial value :	0	0	0	0	0	0	0	0	0	0	0	0	0	0	0	0
R/W :	R	R	R	R	R	R	R	R	R	R	—	—	—	—	—	—



## H'D134: A/D Control Register ADCR: A/D Converter

Bit :	7	6	5	4	3	2	1	0
	CK	—	HCH1	HCH0	SCH3	SCH2	SCH1	SCH0
Initial value :	0	1	0	0	0	0	0	0
R/W :	R/W	—	R/W	R/W	R/W	R/W	R/W	R/W

Software channel select bits

SCH3	SCH2	SCH1	SCH0	Analog input channel
0	0	0	0	AN0
			1	AN1
		1	0	AN2
			1	AN3
	1	0	0	AN4
			1	AN5
		1	0	AN6
1	0	0	1	AN7
			0	AN8
		1	0	AN9
			1	ANA
	1	1	ANB	
1	1	*	*	Software-triggered conversion channel is not selected

Legend: \* Don't care.

Note: If conversion is started by software when SCH3 to SCH0 are set to 11\*\*, the conversion result is undetermined. Hardware- or external-triggered conversion, however, will be performed on the channel selected by HCH1 and HCH0.

Hardware channel select bits

HCH1	HCH2	Analog input channel
0	0	AN8
	1	AN9
1	0	ANA
	1	ANB

Clock select

0	Conversion frequency = 266 states
1	Conversion frequency = 134 states

**H'D135: A/D Control/Status Register ADCSR: A/D Converter**

Bit :	7	6	5	4	3	2	1	0
	SEND	HEND	ADIE	SST	HST	BUSY	SCNL	—
Initial value :	0	0	0	0	0	0	0	1
R/W :	R/(W)*	R/(W)*	R/W	R/W	R	R	R	—

Software-triggered A/D conversion cancel flag	
0	No contention for A/D conversion
1	Indicates that software-triggered A/D conversion was canceled by the start of hardware-triggered A/D conversion.

Busy flag	
0	No contention for A/D conversion
1	Indicates an attempt to execute software-triggered A/D conversion was canceled by the start of hardware-triggered A/D conversion.

Hardware A/D status flag	
0	Read: Hardware- or external -triggered A/D conversion is not in progress Write: Hardware- or external-triggered A/D conversion is aborted
1	Hardware- or external-triggered A/D conversion has ended or been stopped

Software A/D start flag	
0	Read: Indicates that software-triggered A/D conversion has ended or been stopped Write: Software-triggered A/D conversion is aborted
1	Read: Indicates that software-triggered A/D conversion is in progress Write: Starts software-triggered A/D conversion

A/D interrupt enable bit	
0	Interrupt (ADI) upon A/D conversion end is disabled
1	Interrupt (ADI) upon A/D conversion end is enabled

Hardware A/D end flag	
0	[Clearing condition] When 0 is written after reading 1
1	[Setting condition] When hardware- or external-triggered A/D conversion has ended

Software A/D end flag	
0	[Clearing condition] When 0 is written after reading 1
1	[Setting condition] When software-triggered A/D conversion has ended

Note: \* Only 0 can be written to clear the flag.

**H'D136: A/D Trigger Select Register ADTSR: A/D Converter**

Bit :	7	6	5	4	3	2	1	0
	—	—	—	—	—	—	TRGS1	TRGS0
Initial value :	1	1	1	1	1	1	0	0
R/W :	—	—	—	—	—	—	R/W	R/W

Trigger select bits

TRGS1	TRGS0	
0	0	Hardware- or external-triggered A/D conversion is disabled
	1	Hardware-triggered (ADTRG) A/D conversion is selected
1	0	Hardware-triggered (DFG) A/D conversion is selected
	1	External-triggered (ADTRG) A/D conversion is selected

**H'D138: Timer Load Register K TLK: Timer J**

Bit :	7	6	5	4	3	2	1	0
	TLR27	TLR26	TLR25	TLR24	TLR23	TLR22	TLR21	TLR20
Initial value :	1	1	1	1	1	1	1	1
R/W :	W	W	W	W	W	W	W	W

**H'D138: Timer Counter K TCK: Timer J**

Bit :	7	6	5	4	3	2	1	0
	TDR27	TDR26	TDR25	TDR24	TDR23	TDR22	TDR21	TDR20
Initial value :	1	1	1	1	1	1	1	1
R/W :	R	R	R	R	R	R	R	R

**H'D139: Timer Load Register J TLJ: Timer J**

Bit :	7	6	5	4	3	2	1	0
	TLR17	TLR16	TLR15	TLR14	TLR13	TLR12	TLR11	TLR10
Initial value :	1	1	1	1	1	1	1	1
R/W :	W	W	W	W	W	W	W	W

**H'D139: Timer Counter J TCJ: Timer J**

Bit :	7	6	5	4	3	2	1	0
	TDR17	TDR16	TDR15	TDR14	TDR13	TDR12	TDR11	TDR10
Initial value :	1	1	1	1	1	1	1	1
R/W :	R	R	R	R	R	R	R	R

## H'D13A: Timer Mode Register J TMJ: Timer J

Bit :	7	6	5	4	3	2	1	0
	PS11	PS10	ST	8/16	PS21	PS20	TGL	T/R
Initial value :	0	0	0	0	0	0	0	0
R/W :	R/W	R/W	R/W	R/W	R/W	R/W	R	R/W

Timer output/remote-controller output select bit	
0	TMJ-1 timer output
1	TMJ-1 toggle output (data transmitted from remote controller)

TMJ-2 toggle flag	
0	TMJ-2 toggle output is 0
1	TMJ-2 toggle output is 1

TMJ-2 input clock select bits			
PS22 <sup>*3</sup>	PS21	PS20	TMJ-2 input clock select
1	0	0	Counting by the PSS, $\phi/16384$
		1	Counting by the PSS, $\phi/2048$
	1	0	Counting at underflowing of the TMJ-1
		1	Counting at the leading edge or the trailing edge of the external clock inputs (IRQ2) <sup>*1</sup>
0	*	*	Counting by the PSS, $\phi/1024$ <sup>*2</sup>

Legend: \* Don't care.

Notes: 1. The edge selection for the external clock inputs is made by setting the edge select register (IEGR). See section 6.2.4, IRQ Edge Select Register (IEGR) for more information.  
2. Available only in the H8S/2194C Group.

8-bit/16-bit operation select bit	
0	TMJ-1 and TMJ-2 operate separately
1	TMJ-1 and TMJ-2 operate together as 16-bit

Remote-controlled operation start bit	
0	Stop TMJ-1 clock supply in remote control mode
1	Start TMJ-1 clock supply in remote control mode

TMJ-1 input clock select bits		
PS11	PS10	TMJ-1 input clock select
0	0	PSS, count at $\phi/512$
	1	PSS, count at $\phi/256$
1	0	PSS, count at $\phi/4$
	1	Count at rising/falling edge of external clock (IRQ1)

Note: \* External clock edge selection is set in edge select register (IEGR).  
See section explaining edge select register (IEGR).  
When using external clock in remote control mode, set opposite edges for IRQ1 and IRQ2 edges (eg. When falling edge is set for IRQ1, set rising edge for IRQ2).

## H'D13B: Timer J Control Register TMJC: Timer J

Bit :	7	6	5	4	3	2	1	0
	BUZZ1	BUZZ0	MON1	MON0	—	TMJ2IE	TMJ1IE	(PS22)*
Initial value :	0	0	0	0	1	0	0	1
R/W :	R/W	R/W	R/W	R/W	—	R/W	R/W	(R/W)*

H8S/2194 Group: When this is read, 1 will always be readout. Writes are disabled.

H8S/2194C Group: This bit, together with bit 3 and 2 (PS21,PS20) in TMJ, selects the input clock for TMJ-2.

TMJ11 interrupt enable bit

0	TMJ11 interrupt request is disabled
1	TMJ11 interrupt request is enabled

TMJ21 interrupt enable bit

0	TMJ21 interrupt request is disabled
1	TMJ21 interrupt request is enabled

Monitor output select bits

MON1	MON0	Monitor output select
0	0	PB or REC-CTL
	1	DVCTL
1	*	Output TCA7

Legend: \* Don't care.

Buzzer output select bits

BUZZ1	BUZZ0	Output signal	Frequency when $\phi = 10$ MHz
0	0	$\phi/4096$	2.44 kHz
	1	$\phi/8192$	1.22 kHz
1	0	Output monitor signal	
	1	Output Timer J BUZZ signal	

Note: \* Bit 0 is readable/writable only in the H8S/2194C Group.

**H'D13C: Timer J Status Register TMJS: Timer J**

Bit :	7	6	5	4	3	2	1	0
	TMJ2I	TMJ1I	—	—	—	—	—	—
Initial value :	0	0	1	1	1	1	1	1
R/W :	R/(W)*	R/(W)*	—	—	—	—	—	—

TMJ1I interrupt request flag	
0	[Clearing condition] When 0 is written after reading 1
1	[Setting condition] When TMJ-1 underflows

TMJ2I interrupt request flag	
0	[Clearing condition] When 0 is written after reading 1
1	[Setting condition] When TMJ-2 underflows

Note: \* Only 0 can be written to clear the flag.

**H'D148: Serial Mode Register SMR1: SC11**

Bit :	7	6	5	4	3	2	1	0
	C/ $\bar{A}$	CHR	PE	O/ $\bar{E}$	STOP	MP	CKS1	CKS0
Initial value :	0	0	0	0	0	0	0	0
R/W :	R/W	R/W	R/W	R/W	R/W	R/W	R/W	R/W

CKS1	CKS0	Clock select
0	0	$\phi$ clock
	1	$\phi/4$ clock
1	0	$\phi/16$ clock
	1	$\phi/64$ clock

0	Multiprocessor function is disabled
1	Multiprocessor format is selected

0	1 Stop bit <sup>*1</sup>
1	2 Stop bit <sup>*2</sup>

Notes: 1. In transmission, a single 1 bit (stop bit) is added to the end of a transmit character before it is sent.  
2. In transmission, two 1 bits (stop bits) are added to the end of a transmit character before it is sent.

0	Even parity <sup>*1</sup>
1	Odd parity <sup>*2</sup>

Notes: 1. When even parity is set, parity bit addition is performed in transmission so that the total number of 1 bits in the transmit character plus the parity bit is even. In reception, a check is performed to see if the total number of 1 bits in the receive character plus the parity bit is even.  
2. When odd parity is set, parity bit addition is performed in transmission so that the total number of 1 bits in the transmit character plus the parity bit is odd. In reception, a check is performed to see if the total number of 1 bits in the receive character plus the parity bit is odd.

0	Parity bit addition and checking disabled
1	Parity bit addition and checking enabled*

Note: \* When the PE bit is set to 1, the parity (even or odd) specified by the O/ $\bar{E}$  bit is added to transmit data before transmission. In reception, the parity bit is checked for the parity (even or odd) specified by the O/ $\bar{E}$  bit.

0	8-bit data
1	7-bit data

Note: \* When 7-bit data is selected, the MSB (bit 7) of TDR is not transmitted, and LSB-first/MSB-first selection is not available.

0	Start-stop synchronous mode
1	Clock synchronous mode



**H'D149: Bit Rate Register BRR1: SCI1**

Bit :	7	6	5	4	3	2	1	0
	<input type="checkbox"/>	<input type="checkbox"/>	<input type="checkbox"/>	<input type="checkbox"/>	<input type="checkbox"/>	<input type="checkbox"/>	<input type="checkbox"/>	<input type="checkbox"/>
Initial value :	1	1	1	1	1	1	1	1
R/W :	R/W	R/W	R/W	R/W	R/W	R/W	R/W	R/W

## H'D14A: Serial Control Register SCR1: SCI1

Bit :	7	6	5	4	3	2	1	0
	TIE	RIE	TE	RE	MPIE	TEIE	CKE1	CKE0
Initial value :	0	0	0	0	0	0	0	0
R/W :	R/W	R/W	R/W	R/W	R/W	R/W	R/W	R/W

## Clock enable bits

CKE1	CKE0	Clock select	
0	0	Start-stop synchronous mode	Internal clock/SCK1 pin function as I/O port <sup>*1</sup>
		Clock synchronous mode	Internal clock/SCK1 pin function as serial clock output <sup>*1</sup>
	1	Start-stop synchronous mode	Internal clock/SCK1 pin function as clock output <sup>*2</sup>
		Clock synchronous mode	Internal clock/SCK1 pin function as serial clock output
1	0	Start-stop synchronous mode	External clock/SCK1 pin function as clock input <sup>*3</sup>
		Clock synchronous mode	External clock/SCK1 pin function as serial clock input
	1	Start-stop synchronous mode	External clock/SCK1 pin function as clock input <sup>*3</sup>
		Clock synchronous mode	External clock/SCK1 pin function as serial clock input

Notes: 1. Initial value  
2. Outputs a clock of the same frequency as the bit rate.  
3. Inputs a clock with a frequency 16 times the bit rate.

## Transmit end interrupt enable bit

0	Transmit-end interrupt (TEI) request is disabled*
1	Transmit-end interrupt (TEI) request is enabled*

Note: \* TEI cancellation can be performed by reading 1 from the TDRE flag in SSR, then clearing it to 0 and clearing the TEND flag to 0, or clearing the TEIE bit to 0.

## Multiprocessor interrupt enable bit

0	Multiprocessor interrupts are disabled (normal reception performed) [Clearing conditions] (1) When the MPIE bit is cleared to 0 (2) When data with MPB = 1 is received
1	Multiprocessor interrupt are enabled* Receive interrupt (RXI) requests, receive-error interrupt (ERI) requests, and setting of the RDRF, FER, and ORER flags in SSR1 are disabled until data with the multiprocessor bit set to 1 is received.

Note: \* When receive data including MPB = 0 is received, receive data transfer from RSR to RDR1, receive error detection, and setting of the RDRF, FER, and ORER flags in SSR1, is not performed. When receive data with MPB = 1 is received, the MPB bit in SSR1 is set to 1, the MPIE bit is cleared to 0 automatically, and generation of RXI and ERI interrupts (when the TIE and RIE bits in SCR1 are set to 1) and FER and ORER flag setting is enabled.

## Receive enable bit

0	Reception is disabled <sup>*1</sup>
1	Reception is enabled <sup>*2</sup>

Notes: 1. Clearing the RE bit to 0 does not affect the RDRF, FER, PER, and ORER flags, which retain their states.  
2. Serial reception is started in this state when a start bit is detected in asynchronous mode or serial clock input is detected in synchronous mode.  
SMR1 setting must be performed to decide the reception format before setting the RE bit to 1.

## Transmit enable bit

0	Transmission is disabled <sup>*1</sup>
1	Transmission is enabled <sup>*2</sup>

Notes: 1. The TDRE flag in SSR1 is fixed at 1.  
2. In this state, serial transmission is started when transmit data is written to TDR and TDRE flag in SSR1 is cleared to 0.  
SMR1 setting must be performed to decide the transmission format before setting the TE bit to 1.

## Receive interrupt enable bit

0	Receive-data-full interrupt (RXI) request and receive-error interrupt (ERI) request is disabled*
1	Receive-data-full interrupt (RXI) request and receive-error interrupt (ERI) request is enabled

Note: \* RXI and ERI interrupt request cancellation can be performed by reading 1 from the RDRF, FER, PER, or ORER flag, then clearing the flag to 0, or clearing the RIE bit to 0.

## Transmit interrupt enable bit

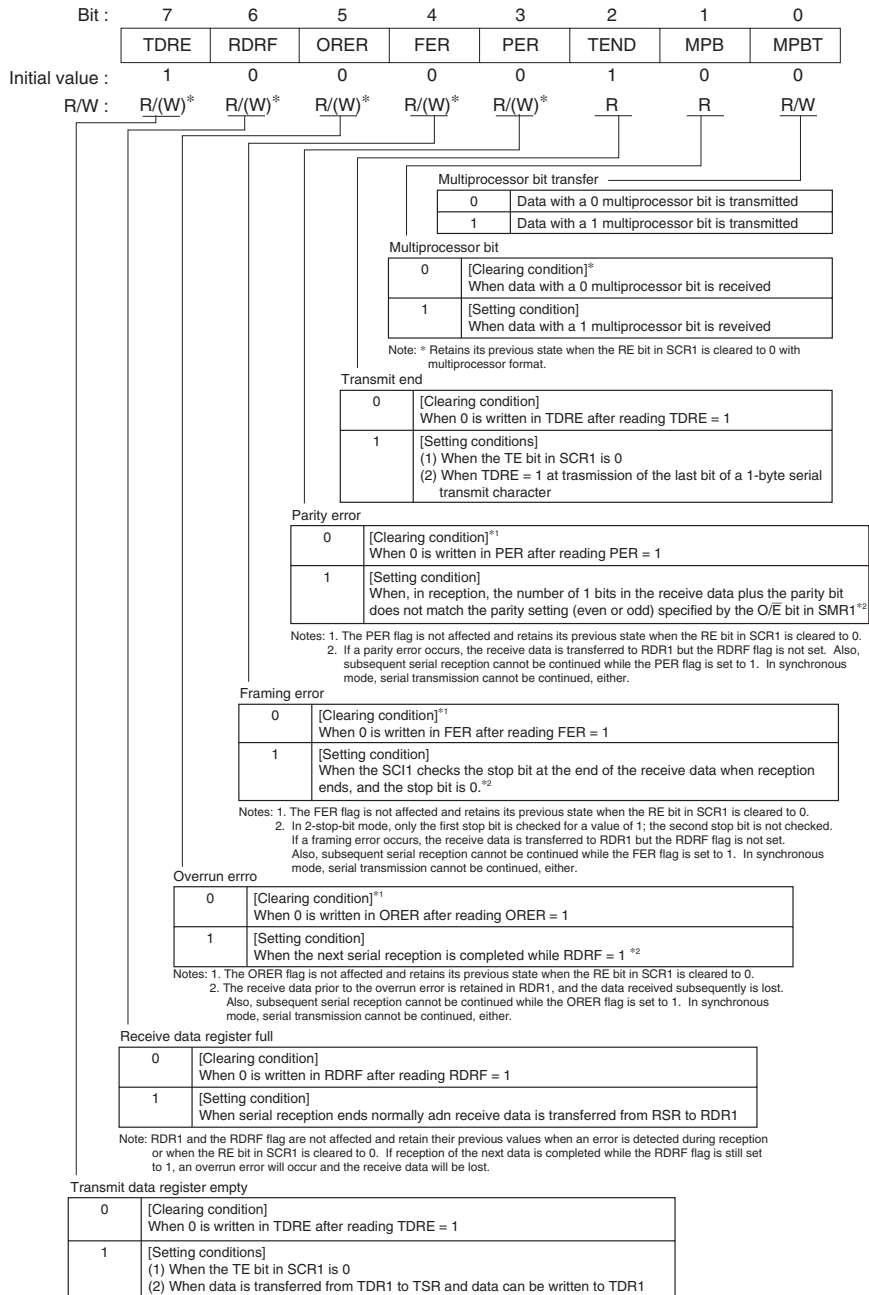
0	Transmit-data-empty interrupt (TXI) request is disabled*
1	Transmit-data-empty interrupt (TXI) request is enabled

Note: \* TXI interrupt request cancellation can be performed by reading 1 from the TDRE flag, then clearing it to 0, or clearing the TIE bit to 0.

**H'D14B: Transmit Data Register TDR1: SCI1**

Bit :	7	6	5	4	3	2	1	0
	<input type="checkbox"/>	<input type="checkbox"/>	<input type="checkbox"/>	<input type="checkbox"/>	<input type="checkbox"/>	<input type="checkbox"/>	<input type="checkbox"/>	<input type="checkbox"/>
Initial value :	1	1	1	1	1	1	1	1
R/W :	R/W	R/W	R/W	R/W	R/W	R/W	R/W	R/W

## H'D14C: Serial Status Register SSR1: SCI1



Note: \* Only 0 can be written to clear the flag.

**H'D14D: Receive Data Register RDR1: SCI1**

Bit :	7	6	5	4	3	2	1	0
Initial value :	0	0	0	0	0	0	0	0
R/W :	R	R	R	R	R	R	R	R

**H'D14E: Serial Interface Mode Register SCMR1: SCI1**

Bit :	7	6	5	4	3	2	1	0
	—	—	—	—	SDIR	SINV	—	SMIF
Initial value :	1	1	1	1	0	0	1	0
R/W :	—	—	—	—	R/W	R/W	—	R/W

Serial communication interface mode select

0	Normal SCI mode
1	Reserved mode

Data invert

0	TDR1 contents are transmitted without modification Receive data is stored in RDR1 without modification
1	TDR1 contents are inverted before being transmitted Receive data is stored in RDR1 in inverted form

Data transfer direction

0	TDR1 contents are transmitted LSB-first Receive data is stored in RDR1 LSB-first
1	TDR1 contents are transmitted MSB-first Receive data is stored in RDR1 MSB-first

H'D158: I<sup>2</sup>C Bus Control Register ICCR: IIC Bus Interface

Bit :	7	6	5	4	3	2	1	0
	ICE	IEIC	MST	TRS	ACKE	BBSY	IRIC	SCP
Initial value :	0	0	0	0	0	0	0	1
R/W :	R/W	R/W	R/W	R/W	R/W	R/W	R/(W)*	W

Start condition/stop condition prohibit	
0	Writing 0 issues a start or stop condition, in combination with the BBSY flag
1	Reading always returns a value of 1 Writing is ignored

I <sup>2</sup> C bus interface interrupt request flag	
0	Waiting for transfer, or transfer in progress [Clearing condition] When 0 is written in IRIC after reading IRIC = 1
1	Interrupt requested [Setting conditions] I <sup>2</sup> C bus format master mode (1) When a start condition is detected in the bus line state after a start condition is issued (when the TDRE flag is set to 1 because of first frame transmission) (2) When a wait is inserted between the data and acknowledge bit when WAIT = 1 (3) At the end of data transfer (at the rise of the 9th transmit clock pulse, and at the fall of the 8th transmit/receive clock pulse when a wait is inserted) (4) When a slave address is received after bus arbitration is lost (when the AL flag is set to 1) (5) When 1 is received as the acknowledge bit when the ACKE bit is 1 (when the ACKB bit is set to 1) I <sup>2</sup> C bus format slave mode (1) When the slave address (SVA, SVAX) matches (when the AAS and AASX flags are set to 1) and at the end of data transfer up to the subsequent retransmission start condition or stop condition detection (when the TDRE or RDRF flag is set to 1) (2) When the general call address is detected (when FS = 0 and the ADZ flag is set to 1) and at the end of data transfer up to the subsequent retransmission start condition or stop condition detection (when the TDRE or RDRF flag is set to 1) (3) When 1 is received as the acknowledge bit when the ACKE bit is 1 (when the ACKB bit is set to 1) (4) When a stop condition is detected (when the STOP or ESTP flag is set to 1) Synchronous serial format (1) At the end of data transfer (when the TDRE or RDRF flag is set to 1) (2) When a start condition is detected with serial format selected When conditions are occurred such that the TDRE or RDRF flag is set to 1

Bus busy	
0	Bus is free [Clearing condition] When a stop condition is detected
1	Bus is busy [Setting condition] When a start condition is detected

Acknowledge bit judgment selection	
0	The value of the acknowledge bit is ignored, and continuous transfer is performed
1	If the acknowledge bit is 1, continuous transfer is interrupted

Master/slave select		
Transmit/receive select		
MST	TRS	
0	0	Slave receive mode
	1	Slave transmit mode
1	0	Master receive mode
	1	Master transmit mode

I <sup>2</sup> C bus interface interrupt enable	
0	Interrupt request is disabled
1	Interrupt request is enabled

I <sup>2</sup> C bus interface enable	
0	I <sup>2</sup> C bus interface module disabled, with SCL and SDA signal pins set to port function. Initialization of the internal state of the I <sup>2</sup> C module. SAR and SARX can be accessed
1	I <sup>2</sup> C bus interface module enabled for transfer operation (pins SCL and SDA are driving the bus)

Note: \* Only 0 can be written to clear the flag.

H'D159: I<sup>2</sup>C Bus Status Register ICSR: IIC Bus Interface

Bit :	7	6	5	4	3	2	1	0
	ESTP	STOP	IRTR	AASX	AL	AAS	ADZ	ACKB
Initial value :	0	0	0	0	0	0	0	0
R/W :	R/(W)*	R/(W)*	R/(W)*	R/(W)*	R/(W)*	R/(W)*	R/(W)*	R/W
								Acknowledge bit 0 Receive mode: 0 is output at acknowledge output timing Transmit mode: Indicates that the receiving device has acknowledged the data (signal is 0) 1 Receive mode: 1 is output at acknowledge output timing
								General call address recognition flag 0 General call address not recognized [Clearing conditions] (1) When ICDR data is written (transmit mode) or read (receive mode) (2) When 0 is written in ADZ after reading ADZ = 1 (3) In master mode 1 General call address recognized [Setting condition] When the general call address is detected in slave receive mode
								Slave address recognition flag 0 Slave address or general call address not recognized [Clearing conditions] (1) When ICDR data is written (transmit mode) or read (receive mode) (2) When 0 is written in AAS after reading AAS = 1 (3) In master mode 1 Slave address or general call address recognized [Setting condition] When the slave address or general call address is detected in slave receive mode
								Arbitration lost flag 0 Bus arbitration won [Clearing conditions] (1) When ICDR data is written (transmit mode) or read (receive mode) (2) When 0 is written in AL after reading AL = 1 1 Arbitration lost [Setting conditions] (1) If the internal SDA and SDA pin disagree at the rise of SCL in master transmit mode (2) If the internal SCL line is high at the fall of SCL in master transmit mode
								Second slave address recognition flag 0 Second slave address not recognized [Clearing conditions] (1) When 0 is written in AASX after reading AASX = 1 (2) When a start condition is detected (3) In master mode 1 Second slave address recognized [Setting condition] When the second slave address is detected in slave receive mode while FSX = 0
								I <sup>2</sup> C bus interface continuous transmission/reception interrupt request flag 0 Waiting for transfer, or transfer in progress [Clearing conditions] (1) When 0 is written in IRTR after reading IRTR = 1 (2) When the IRIC flag is cleared to 0 1 Continuous transfer state [Setting conditions] in I <sup>2</sup> C bus interface slave mode When the TDRE or RDRF flag is set to 1 when AASX = 1 In other mode When the TDRE or RDRF flag is set to 1
								Normal stop condition detection flag 0 No normal stop condition [Clearing conditions] (1) When 0 is written in STOP after reading STOP = 1 (2) When the IRIC flag is cleared to 0 1 In I <sup>2</sup> C bus format slave mode Normal stop condition detected [Setting condition] When a stop condition is detected after completion of frame transfer In other mode No meaning
								Error stop condition detection flag 0 No error stop condition [Clearing conditions] (1) When 0 is written in ESTP after reading ESTP = 1 (2) When the IRIC flag is cleared to 0 1 In I <sup>2</sup> C bus format slave mode Error stop condition detected [Setting condition] When a stop condition is detected during frame transfer In other mode No meaning


Note: \* Only 0 can be written to clear the flag.

**H'D15E: I<sup>2</sup>C Bus Data Register ICDR: IIC Bus Interface**

Bit :	7	6	5	4	3	2	1	0
	ICDR7	ICDR6	ICDR5	ICDR4	ICDR3	ICDR2	ICDR1	ICDR0
Initial value :	—	—	—	—	—	—	—	—
R/W :	R/W	R/W	R/W	R/W	R/W	R/W	R/W	R/W

**H'D15E: Second Slave Address Register SARX: IIC Bus Interface**

Bit :	7	6	5	4	3	2	1	0
	SVAX6	SVAX5	SVAX4	SVAX3	SVAX2	SVAX1	SVAX0	FSX
Initial value :	0	0	0	0	0	0	0	1
R/W :	R/W	R/W	R/W	R/W	R/W	R/W	R/W	R/W

Format select   
 Used combined with SAR FS bit.



H'D15F: I<sup>2</sup>C Bus Mode Register ICMR: IIC Bus Interface

Bit :	7	6	5	4	3	2	1	0
	MLS	WAIT	CKS2	CKS1	CKS0	BC2	BC1	BC0
Initial value :	0	0	0	0	0	0	0	0
R/W :	R/W	R/W	R/W	R/W	R/W	R/W	R/W	R/W

Bit counter			Bit/frame	
BC2	BC1	BC0	Clock sync serial format	I <sup>2</sup> C bus format
0	0	0	8	9
		1	1	2
		1	0	2
0	1	0	3	4
		1	4	5
		1	5	6
1	0	0	6	7
		1	7	8
		1	7	8

Transfer clock select bits

IICX*	CKS2	CKS1	CKS0	Clock	Transfer rate		
					$\phi = 5$ MHz	$\phi = 8$ MHz	$\phi = 10$ MHz
0	0	0	0	$\phi/28$	179 kHz	286 kHz	357 kHz
			1	$\phi/40$	125 kHz	200 kHz	250 kHz
		1	0	$\phi/48$	104 kHz	167 kHz	208 kHz
			1	$\phi/64$	78.1 kHz	125 kHz	156 kHz
	1	0	0	$\phi/80$	62.5 kHz	100 kHz	125 kHz
			1	$\phi/100$	50.0 kHz	80.0 kHz	100 kHz
		1	0	$\phi/112$	44.6 kHz	71.4 kHz	89.3 kHz
			1	$\phi/128$	39.1 kHz	62.5 kHz	78.1 kHz
1	0	0	0	$\phi/56$	89.3 kHz	143 kHz	179 kHz
			1	$\phi/80$	62.5 kHz	100 kHz	125 kHz
		1	0	$\phi/96$	52.1 kHz	83.3 kHz	104 kHz
			1	$\phi/128$	39.1 kHz	62.5 kHz	78.1 kHz
	1	0	0	$\phi/160$	31.3 kHz	50.0 kHz	62.5 kHz
			1	$\phi/200$	25.0 kHz	40.0 kHz	50.0 kHz
		1	0	$\phi/224$	22.3 kHz	35.7 kHz	44.6 kHz
			1	$\phi/256$	19.5 kHz	31.3 kHz	39.1 kHz

Note: \* See STCR Bit 6.

Wait insertion bit

0	Data and acknowledge bits transferred consecutively
1	Wait inserted between data and acknowledge bits

MSB-first/LSB-first select

0	MSB-first
1	LSB-first

**H'D15F: Slave Address Register SAR: IIC Bus Interface**

Bit :	7	6	5	4	3	2	1	0
	SVA6	SVA5	SVA4	SVA3	SVA2	SVA1	SVA0	FS
Initial value :	0	0	0	0	0	0	0	0
R/W :	R/W	R/W	R/W	R/W	R/W	R/W	R/W	R/W

Format select bit

SAR Bit 0	SARX Bit 0	Format select
FS	FX	
0	0	I <sup>2</sup> C bus format • SAR and SARX slave addresses recognized
	1	I <sup>2</sup> C bus format • SAR slave address recognized • SARX slave address ignored
1	0	I <sup>2</sup> C bus format • SAR slave address ignored • SARX slave address recognized
	1	I <sup>2</sup> C bus format • SAR and SARX slave addresses ignored

**H'FFB0: Trap Address Register 0 TAR0: ATC****H'FFB3: Trap Address Register 1 TAR1: ATC****H'FFB6: Trap Address Register 2 TAR2: ATC**

Bit :	7	6	5	4	3	2	1	0
	A23	A22	A21	A20	A19	A18	A17	A16
Initial value :	0	0	0	0	0	0	0	0
R/W :	R/W	R/W	R/W	R/W	R/W	R/W	R/W	R/W

Bit :	7	6	5	4	3	2	1	0
	A15	A14	A13	A12	A11	A10	A9	A8
Initial value :	0	0	0	0	0	0	0	0
R/W :	R/W	R/W	R/W	R/W	R/W	R/W	R/W	R/W

Bit :	7	6	5	4	3	2	1	0
	A7	A6	A5	A4	A3	A2	A1	—
Initial value :	0	0	0	0	0	0	0	0
R/W :	R/W	R/W	R/W	R/W	R/W	R/W	R/W	—

**H'FFB9: Address Trap Control Register ATCR: ATC**

Bit :	7	6	5	4	3	2	1	0
	—	—	—	—	—	TRC2	TRC1	TRC0
Initial value :	1	1	1	1	1	0	0	0
R/W :	—	—	—	—	—	R/W	R/W	R/W

0	Address trap function 0 is disabled
1	Address trap function 0 is enabled

0	Address trap function 1 is disabled
1	Address trap function 1 is enabled

0	Address trap function 2 is disabled
1	Address trap function 2 is enabled

## H'FFBA: Timer Mode Register A TMA: Timer A

Bit :	7	6	5	4	3	2	1	0
	TMAOV	TMAIE	—	—	TMA3	TMA2	TMA1	TMA0
Initial value :	0	0	1	1	0	0	0	0
R/W :	R/(W)*	R/W	—	—	R/W	R/W	R/W	R/W

Clock select bits

TMA3	TMA2	TMA1	TMA0	Prescaler frequency division rate (interval timer) or overflow frequency (time-base)	Operation mode
0	0	0	0	PSS, $\phi/16384$	Interval timer mode
			1	PSS, $\phi/8192$	
		1	0	PSS, $\phi/4096$	
			1	PSS, $\phi/1024$	
	1	0	0	PSS, $\phi/512$	
			1	PSS, $\phi/256$	
		1	0	PSS, $\phi/64$	
			1	PSS, $\phi/16$	
1	0	0	0	1 s	Clock time base mode
			1	0.5 s	
		1	0	0.25 s	
			1	0.03125 s	
	1	0	0	Clear PSW and TCA to H'00	
			1		
		1	0		
			1		

Note:  $\phi = f_{osc}$ 

Clock source, prescaler select bit

0	Timer A clock source is PSS
1	Timer A clock source is PSW

Timer A interrupt enable bit

0	Interrupt request by Timer A (TMAI) is disabled
1	Interrupt request by Timer A (TMAI) is enabled

Timer A overflow flag

0	[Clearing condition] When 0 is written to TMAOV after reading TMAOV = 1
1	[Setting condition] When TCA overflows

Note: \* Only 0 can be written to clear the flag.

**H'FFBB: Timer Counter A TCA: TimerA**

Bit :	7	6	5	4	3	2	1	0
	TCA7	TCA6	TCA5	TCA4	TCA3	TCA2	TCA1	TCA0
Initial value :	0	0	0	0	0	0	0	0
R/W :	R	R	R	R	R	R	R	R

**H'FFBC: Watchdog Timer Control/Status Register WTCSR: WDT**

Bit :	7	6	5	4	3	2	1	0
	OVF	WT/IT	TME	RSTS	RST/NMI	CKS2	CKS1	CKS0
Initial value :	0	0	0	0	0	0	0	0
R/W :	R/(W)*	R/W	R/W	R/W	R/W	R/W	R/W	R/W

Reset or NMI

0	NMI interrupt request is disabled
1	Internal reset request is generated

Timer enable bit

0	WTCNT is initialized to H'00 and halted
1	WTCNT counts

Timer mode select bit

0	Interval timer mode: Sends the CPU an interval timer interrupt request (WOVI) when WTCNT overflows
1	Watchdog timer mode: Sends the CPU a reset or NMI interrupt request when WTCNT overflows

Overflow flag

0	[Clearing conditions] (1) Write 0 in the TME bit (2) Read WTCSR when OVF = 1, then write 0 in OVF
1	[Setting condition] When WTCNT overflows (changes from H'FF to H'00) (When internal reset request generation is selected in watchdog timer mode, OVF is cleared automatically by the internal reset.)

Note: \* Only 0 can be written to clear the flag.

**H'FFBD: Watchdog Timer Counter WTCNT: WDT**

Bit :	7	6	5	4	3	2	1	0
Initial value :	0	0	0	0	0	0	0	0
R/W :	R/W	R/W	R/W	R/W	R/W	R/W	R/W	R/W

**H'FFC0: Port Data Register 0 PDR0: I/O Port**

Bit :	7	6	5	4	3	2	1	0
	PDR07	PDR06	PDR05	PDR04	PDR03	PDR02	PDR01	PDR00
Initial value :	—	—	—	—	—	—	—	—
R/W :	R	R	R	R	R	R	R	R

**H'FFC1: Port Data Register 1 PDR1: I/O Port**

Bit :	7	6	5	4	3	2	1	0
	PDR17	PDR16	PDR15	PDR14	PDR13	PDR12	PDR11	PDR10
Initial value :	0	0	0	0	0	0	0	0
R/W :	R/W	R/W	R/W	R/W	R/W	R/W	R/W	R/W

**H'FFC2: Port Data Register 2 PDR2: I/O Port**

Bit :	7	6	5	4	3	2	1	0
	PDR27	PDR26	PDR25	PDR24	PDR23	PDR22	PDR21	PDR20
Initial value :	0	0	0	0	0	0	0	0
R/W :	R/W	R/W	R/W	R/W	R/W	R/W	R/W	R/W

**H'FFC3: Port Data Register 3 PDR3: I/O Port**

Bit :	7	6	5	4	3	2	1	0
	PDR37	PDR36	PDR35	PDR34	PDR33	PDR32	PDR31	PDR30
Initial value :	0	0	0	0	0	0	0	0
R/W :	R/W	R/W	R/W	R/W	R/W	R/W	R/W	R/W

**H'FFC4: Port Data Register 4 PDR4: I/O Port**

Bit :	7	6	5	4	3	2	1	0
	PDR47	PDR46	PDR45	PDR44	PDR43	PDR42	PDR41	PDR40
Initial value :	0	0	0	0	0	0	0	0
R/W :	R/W	R/W	R/W	R/W	R/W	R/W	R/W	R/W

**H'FFC5: Port Data Register 5 PDR5: I/O Port**

Bit :	7	6	5	4	3	2	1	0
	—	—	—	—	PDR53	PDR52	PDR51	PDR50
Initial value :	1	1	1	1	0	0	0	0
R/W :	—	—	—	—	R/W	R/W	R/W	R/W

**H'FFC6: Port Data Register 6 PDR6: I/O Port**

Bit :	7	6	5	4	3	2	1	0
	PDR67	PDR66	PDR65	PDR64	PDR63	PDR62	PDR61	PDR60
Initial value :	0	0	0	0	0	0	0	0
R/W :	R/W	R/W	R/W	R/W	R/W	R/W	R/W	R/W

**H'FFC7: Port Data Register 7 PDR7: I/O Port**

Bit :	7	6	5	4	3	2	1	0
	PDR77	PDR76	PDR75	PDR74	PDR73	PDR72	PDR71	PDR70
Initial value :	0	0	0	0	0	0	0	0
R/W :	R/W	R/W	R/W	R/W	R/W	R/W	R/W	R/W

**H'FFC8: Port Data Register 8 PDR8: I/O Port**

Bit :	7	6	5	4	3	2	1	0
	PDR87	PDR86	PDR85	PDR84	PDR83	PDR82	PDR81	PDR80
Initial value :	0	0	0	0	0	0	0	0
R/W :	R/W	R/W	R/W	R/W	R/W	R/W	R/W	R/W

**H'FFCD: Port Mode Register 0 PMR0: I/O Port**

Bit :	7	6	5	4	3	2	1	0
	PMR07	PMR06	PMR05	PMR04	PMR03	PMR02	PMR01	PMR00
Initial value :	0	0	0	0	0	0	0	0
R/W :	R/W	R/W	R/W	R/W	R/W	R/W	R/W	R/W

P07/AN7 to P00/IRQ0 pin function select bits

0	P0n/ANn pin functions as P0n input port
1	P0n/ANn pin functions as ANn input port

Note: n = 7 to 0

**H'FFCE: Port Mode Register 1 PMR1: I/O Port**

Bit :	7	6	5	4	3	2	1	0
	PMR17	PMR16	PMR15	PMR14	PMR13	PMR12	PMR11	PMR10
Initial value :	0	0	0	0	0	0	0	0
R/W :	R/W	R/W	R/W	R/W	R/W	R/W	R/W	R/W

P15/IRQ5 to P10/IRQ0 pin function select bits

0	P1n/IRQn pin functions as P1n I/O port
1	P1n/IRQn pin functions as IRQn input port

Note: n = 5 to 0

P16/IC pin function select bit

0	P16/IC pin functions as P16 I/O port
1	P16/IC pin functions as IC input port

P17/TMOW pin function select bit

0	P17/TMOW pin functions as P17 I/O port
1	P17/TMOW pin functions as TMOW output port



**H'FFCF: Port Mode Register 2 PMR2: I/O Port**

Bit :	7	6	5	4	3	2	1	0
	PMR27	PMR26	PMR25	—	—	—	—	PMR20
Initial value :	0	0	0	1	1	1	1	0
R/W :	R/W	R/W	R/W	—	—	—	—	R/W

P26/SO2 pin PMOS control bit	
0	P26/SO2 pin functions as CMOS output
1	P26/SO2 pin functions as NMOS open drain output

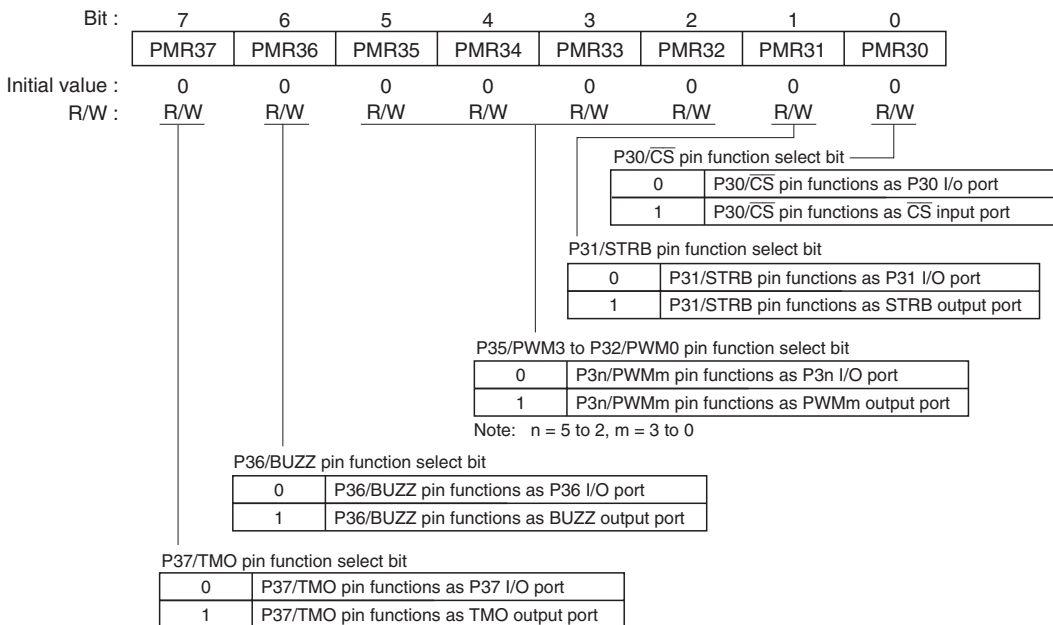
P25/SI2 pin function select bit	
0	P25/SI2 pin functions as P25 I/O port
1	P25/SI2 pin functions as SI2 input port

P26/SO2 pin function select bit	
0	P26/SO2 pin functions as P26 I/O port
1	P26/SO2 pin functions as SO2 output port

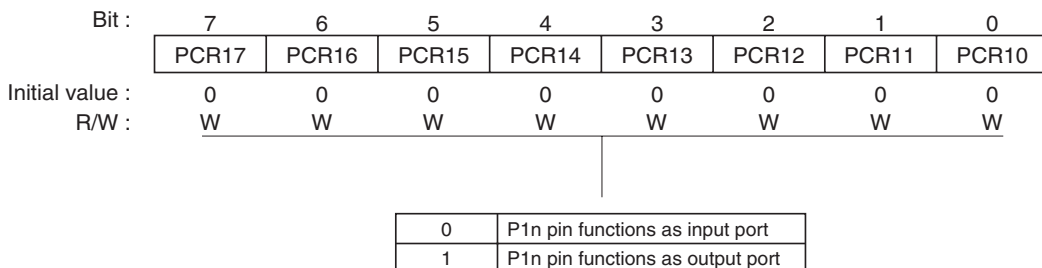
  

P27/SCK2 pin function select bit	
0	P27/SCK2 pin functions as P27 I/O port
1	P27/SCK2 pin functions as SCK2 I/O port

**H'FFD0: Port Mode Register 3 PMR3: I/O Port**

Notes: If the TMO pin is used for remote control sending, a careless timer output pulse may be output when the remote control mode is set after the output has been switched to the TMO output. Perform the switching and setting in the following order.

- [1] Set the remote control mode.
- [2] Set the TMJ-1 and 2 counter data of the timer J.
- [3] Switch the P37/TMO pin to the TMO output pin.
- [4] Set the ST bit to 1.

**H'FFD1: Port Control Register 1 PCR1: I/O Port**

Note: n = 7 to 0

**H'FFD2: Port Control Register 2 PCR2: I/O Port**

Bit :	7	6	5	4	3	2	1	0
	PCR27	PCR26	PCR25	PCR24	PCR23	PCR22	PCR21	PCR20
Initial value :	0	0	0	0	0	0	0	0
R/W :	W	W	W	W	W	W	W	W

0	P2n pin functions as input port
1	P2n pin functions as output port

Note: n = 7 to 0

**H'FFD3: Port Control Register 3 PCR3: I/O Port**

Bit :	7	6	5	4	3	2	1	0
	PCR37	PCR36	PCR35	PCR34	PCR33	PCR32	PCR31	PCR30
Initial value :	0	0	0	0	0	0	0	0
R/W :	W	W	W	W	W	W	W	W

0	P3n pin functions as input port
1	P3n pin functions as output port

Note: n = 7 to 0

**H'FFD4: Port Control Register 4 PCR4: I/O Port**

Bit :	7	6	5	4	3	2	1	0
	PCR47	PCR46	PCR45	PCR44	PCR43	PCR42	PCR41	PCR40
Initial value :	0	0	0	0	0	0	0	0
R/W :	W	W	W	W	W	W	W	W

0	P4n pin functions as input port
1	P4n pin functions as output port

Note: n = 7 to 0

**H'FFD5: Port Control Register 5 PCR5: I/O Port**

Bit :	7	6	5	4	3	2	1	0
	—	—	—	—	PCR53	PCR52	PCR51	PCR50
Initial value :	1	1	1	1	0	0	0	0
R/W :	—	—	—	—	W	W	W	W

0	P5n pin functions as input port
1	P5n pin functions as output port

Note: n = 3 to 0

**H'FFD6: Port Control Register 6 PCR6: I/O Port**

Bit :	7	6	5	4	3	2	1	0
	PCR67	PCR66	PCR65	PCR64	PCR63	PCR62	PCR61	PCR60
Initial value :	0	0	0	0	0	0	0	0
R/W :	W	W	W	W	W	W	W	W

PMR6n	PCR6n	Port Control Register 6
0	0	P6n/RPn pin functions as P6n general purpose input port
	1	P6n/RPn pin functions as P6n general purpose output port
1	*	P6n/RPn pin functions as RPn realtime output port

Legend: \* Don't care.

Note: n = 7 to 0

**H'FFD7: Port Control Register 7 PCR7: I/O Port**

Bit :	7	6	5	4	3	2	1	0
	PCR77	PCR76	PCR75	PCR74	PCR73	PCR72	PCR71	PCR70
Initial value :	0	0	0	0	0	0	0	0
R/W :	W	W	W	W	W	W	W	W

0	P7n pin functions as input port
1	P7n pin functions as output port

Note: n = 7 to 0

**H'FFD8: Port Control Register 8 PCR8: I/O Port**

Bit :	7	6	5	4	3	2	1	0
	PCR87	PCR86	PCR85	PCR84	PCR83	PCR82	PCR81	PCR80
Initial value :	0	0	0	0	0	0	0	0
R/W :	W	W	W	W	W	W	W	W

0	P8n pin functions as input port
1	P8n pin functions as output port

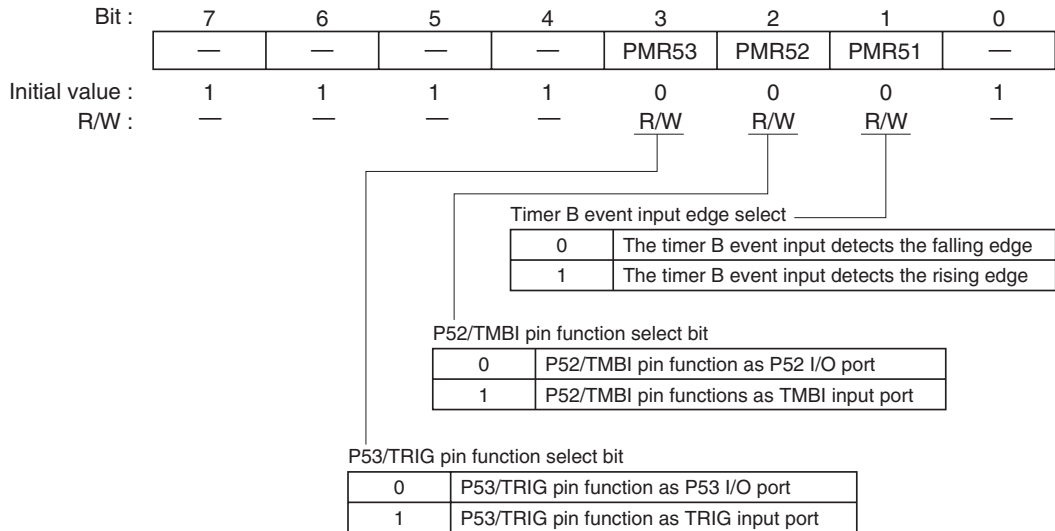
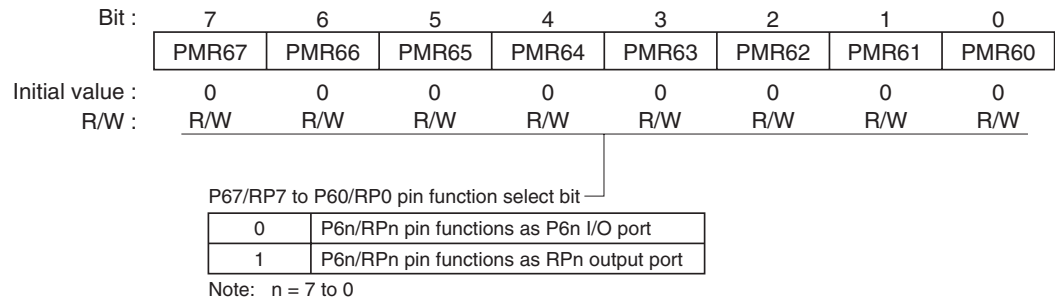
Note: n = 7 to 0

**H'FFDB: Port Mode Register 4 PMR4: I/O Port**

Bit :	7	6	5	4	3	2	1	0
	—	—	—	—	—	—	—	PMR40
Initial value :	1	1	1	1	1	1	1	0
R/W :	—	—	—	—	—	—	—	R/W

P40/PWM14 pin function select bit

0	P40/PWM14 pin functions as P40 I/O port
1	P40/PWM14 pin functions as PWM14 output port

**H'FFDC: Port Mode Register 5: PMR5: I/O Port****H'FFDD: Port Mode Register 6 PMR6: I/O Port**

**H'FFDE: Port Mode Register 7 PMR7: I/O Port**

Bit :	7	6	5	4	3	2	1	0
	PMR77	PMR76	PMR75	PMR74	PMR73	PMR72	PMR71	PMR70
Initial value :	0	0	0	0	0	0	0	0
R/W :	R/W	R/W	R/W	R/W	R/W	R/W	R/W	R/W

P77/PPG7 to P70/PPG0 pin function select bit

0	P7n/PPGn pin functions as P7n I/O port
1	P7n/PPGn pin functions as PPGn output port

Note: n = 7 to 0

**H'FFDF: Port Mode Register 8 PMR8: I/O Port**

Bit :	7	6	5	4	3	2	1	0
	—	—	—	—	PMR83	PMR82	PMR81	PMR80
Initial value :	1	1	1	1	0	0	0	0
R/W :	—	—	—	—	R/W	R/W	R/W	R/W

P80/EXTTRG pin function select bit

0	P80/EXTTRG pin functions as P80 I/O port
1	P80/EXTTRG pin functions as EXTTRG input port

P81/EXCAP pin function select bit

0	P81/EXCAP pin functions as P81 I/O port
1	P81/EXCAP pin functions as EXCAP input port

P82/SV1 pin function select bit

0	P82/SV1 pin functions as P82 I/O port
1	P82/SV1 pin functions as SV1 output port

P83/SV2 pin function select bit

0	P83/SV2 pin functions as P83 I/O port
1	P83/SV2 pin functions as SV2 output port

**H'FFE1: Pull-Up MOS Select Register 1 PUR1: I/O Port**

Bit :	7	6	5	4	3	2	1	0
	PUR17	PUR16	PUR15	PUR14	PUR13	PUR12	PUR11	PUR10
Initial value :	0	0	0	0	0	0	0	0
R/W :	R/W	R/W	R/W	R/W	R/W	R/W	R/W	R/W

0	P1n pin has no pull-up MOS transistor
1	P1n pin has pull-up MOS transistor

Note: n = 7 to 0

**H'FFE2: Pull-Up MOS Select Register 2 PUR2: I/O Port**

Bit :	7	6	5	4	3	2	1	0
	PUR27	PUR26	PUR25	PUR24	PUR23	PUR22	PUR21	PUR20
Initial value :	0	0	0	0	0	0	0	0
R/W :	R/W	R/W	R/W	R/W	R/W	R/W	R/W	R/W

0	P2n pin has no pull-up MOS transistor
1	P2n pin has pull-up MOS transistor

Note: n = 7 to 0

**H'FFE3: Pull-Up MOS Select Register 3 PUR3: I/O Port**

Bit :	7	6	5	4	3	2	1	0
	PUR37	PUR36	PUR35	PUR34	PUR33	PUR32	PUR31	PUR30
Initial value :	0	0	0	0	0	0	0	0
R/W :	R/W	R/W	R/W	R/W	R/W	R/W	R/W	R/W

0	P3n pin has no pull-up MOS transistor
1	P3n pin has pull-up MOS transistor

Note: n = 7 to 0



**H'FFE4: Realtime Output Trigger Edge Select Register RTPEGR: I/O Port**

Bit :	7	6	5	4	3	2	1	0
	—	—	—	—	—	—	RTPEGR1	RTPEGR0
Initial value :	1	1	1	1	1	1	0	0
R/W :	—	—	—	—	—	—	R/W	R/W

Realtime output trigger edge select bit

RTPEGR1	RTPEGR0	Realtime output trigger edge select
0	0	Trigger input is disabled
	1	Rising edge of trigger input is selected
1	0	Falling edge of trigger input is selected
	1	Rising and falling edges of trigger input is selected

**H'FFE5: Realtime Output Trigger Select Register RTPSR: I/O Port**

Bit :	7	6	5	4	3	2	1	0
	RTPSR7	RTPSR6	RTPSR5	RTPSR4	RTPSR3	RTPSR2	RTPSR1	RTPSR0
Initial value :	0	0	0	0	0	0	0	0
R/W :	R/W	R/W	R/W	R/W	R/W	R/W	R/W	R/W

0	External trigger (TRIG pin) input is selected
1	Internal trigger (HSW) input is selected

Note: n = 7 to 0

**H'FFE8: System Control Register SYSCR: System Control**

Bit :	7	6	5	4	3	2	1	0
	—	—	INTM1	INTM0	XRST	NMIEG1	NMIEG0	—
Initial value :	0	0	0	0	1	0	0	1
R/W :	—	—	R	R/W	R	R/W	R/W	—

NMI edge select bits

NMIEG1	NMIEG0	NMI edge select
0	0	Interrupt request is generated at falling edge of NMI input
	1	Interrupt request is generated at rising edge of NMI input
1	*	Interrupt request is generated at rising or falling edge of NMI input

Legend: \* Don't care.

External reset

0	Reset is generated by watchdog timer overflow
1	Reset is generated by external reset input

Interrupt control mode

INTM1	INTM0	Interrupt control mode	Interrupt control
0	0	0	Interrupt is controlled by I bit
	1	1	Interrupt is controlled by I and UI bits and ICR
1	0	2	Cannot be used in the H8S/2194 Group
	1	3	Cannot be used in the H8S/2194 Group

**H'FFE9: Mode Control Register MDCR: System Control**

Bit :	7	6	5	4	3	2	1	0
	—	—	—	—	—	—	—	MDS0
Initial value :	0	0	0	0	0	0	0	—*
R/W :	—	—	—	—	—	—	—	R

Mode select 0

Note: \* Determined by MD0 pin.

**H'FFEA: Standby Control Register SBYCR: System Control**

Bit :	7	6	5	4	3	2	1	0
	SSBY	STS2	STS1	STS0	—	—	SCK1	SCK0
Initial value :	0	0	0	0	0	0	0	0
R/W :	R/W	R/W	R/W	R/W	—	—	R/W	R/W

System clock select

SCK1	SCK0	System clock select
0	0	Bus master is in high-speed mode
0	1	Medium-speed clock is $\phi/16$
1	0	Medium-speed clock is $\phi/32$
1	1	Medium-speed clock is $\phi/64$

Standby timer select bits

STS2	STS1	STS0	Standby time
0	0	0	8192 states
0	0	1	16384 states
0	1	0	32768 states
0	1	1	65536 states
1	0	0	131072 states
1	0	1	262144 states
1	1	*	16 states <sup>*1</sup>

Legend: \* Don't care.

Note: 1. The standby time is 32 states when transitioned to medium-speed mode  $\phi/32$  (SCK = 1, SCK = 0). Do not select 16 states for Flash ROM version.

Software standby

0	Transition to sleep mode after execution of SLEEP instruction in high-speed mode or medium-speed mode Transition to subsleep mode after execution of SLEEP instruction in subactive mode
1	Transition to standby mode, subactive mode, or watch mode after execution of SLEEP instruction in high-speed mode or medium-speed mode Transition to watch mode or high-speed mode after execution of SLEEP instruction in subactive mode

**H'FFEB: Low-Power Control Register LPWRCR: System Control**

Bit :	7	6	5	4	3	2	1	0
	DTON	LSON	NESEL	—	—	—	SA1	SA0
Initial value :	0	0	0	0	0	0	0	0
R/W :	R/W	R/W	R/W	—	—	—	R/W	R/W

Subactive mode clock select

SA1	SA0	Subactive mode clock select
0	0	Operating clock of CPU is $\phi/w/8$
0	1	Operating clock of CPU is $\phi/w/4$
1	*	Operating clock of CPU is $\phi/w/2$

Legend: \* Don't care.

Noise elimination sampling frequency select

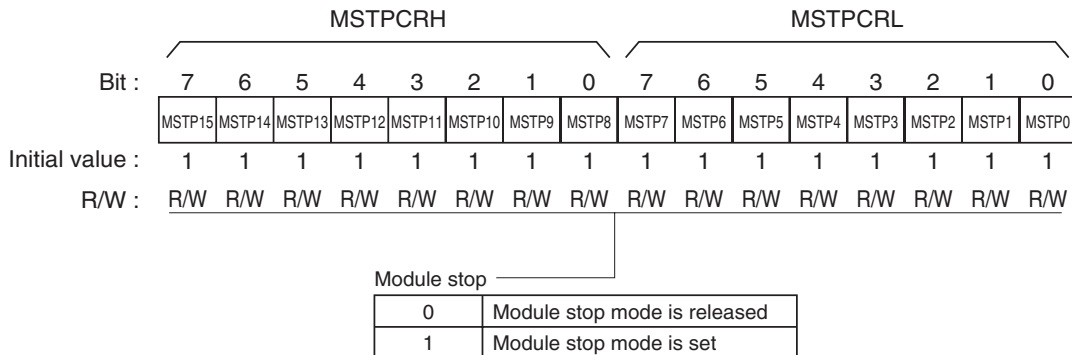
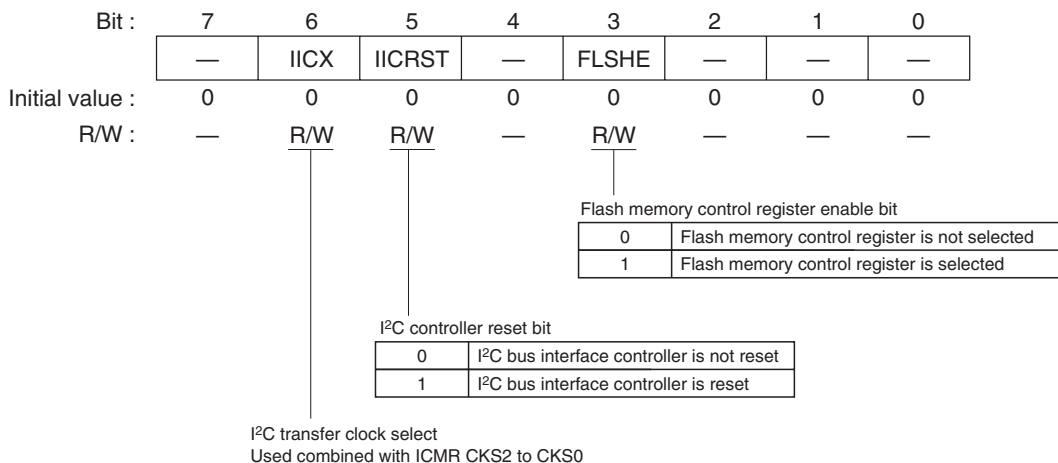
0	Sampling at $\phi$ divided by 16
1	Sampling at $\phi$ divided by 4

Low-speed on flag

0	<ul style="list-style-type: none"> <li>When a SLEEP instruction is executed in high-speed mode or medium-speed mode, a transition is made to sleep mode, standby mode, or watch mode</li> <li>When a SLEEP instruction is executed in subactive mode, a transition is made to watch mode, or directly to high-speed mode</li> <li>After watch mode is cleared, a transition is made to high-speed mode</li> </ul>
1	<ul style="list-style-type: none"> <li>When a SLEEP instruction is executed in high-speed mode a transition is made to watch mode, subactive mode, sleep mode or standby mode.</li> <li>When a SLEEP instruction is executed in subactive mode, a transition is made to subsleep mode or watch mode.</li> <li>After watch mode is cleared, a transition is made to subactive mode</li> </ul>

Direct transfer on flag

0	<ul style="list-style-type: none"> <li>When a SLEEP instruction is executed in high-speed mode or medium-speed mode, a transition is made to sleep mode, standby mode, or watch mode</li> <li>When a SLEEP instruction is executed in subactive mode, a transition is made to watch mode, or directly to high-speed mode</li> </ul>
1	<ul style="list-style-type: none"> <li>When a SLEEP instruction is executed in high-speed mode or medium-speed mode, a transition is made directly to subactive mode*, or a transition is made to sleep mode or standby mode</li> <li>When a SLEEP instruction is executed in subactive mode, a transition is made directly to high-speed mode, or a transition is made to subsleep mode</li> </ul>

**H'FFEC: Module Stop Control Register MSTPCRH: System Control****H'FFED: Module Stop Control Register MSTPCRL: System Control****H'FFEE: Serial Timer Control Register STCR: System Control**

**H'FFF0: IRQ Edge Select Register IEGR: Interrupt Controller**

Bit :	7	6	5	4	3	2	1	0
	—	IRQ5EG	IRQ4EG	IRQ3EG	IRQ2EG	IRQ1EG	IRQ0EG1	IRQ0EG0
Initial value :	0	0	0	0	0	0	0	0
R/W :	—	R/W	R/W	R/W	R/W	R/W	R/W	R/W

IRQ0 pin detected edge select bits

IRQ0EG1	IRQ0EG0	IRQ0 pin detected edge select
0	0	Interrupt request generated at falling edge of IRQ0 pin input
0	1	Interrupt request generated at rising edge of IRQ0 pin input
1	*	Interrupt request generated at both falling and rising edge of IRQ0 pin input

Legend: \* Don't care.

IRQ5 to IRQ1 pins detected edge select bits

0	Interrupt request generated at falling edge of IRQn pin input
1	Interrupt request generated at rising edge of IRQn pin input

Note: n = 5 to 1

**H'FFF1: IRQ Enable Register IENR: Interrupt Controller**

Bit :	7	6	5	4	3	2	1	0
	—	—	IRQ5E	IRQ4E	IRQ3E	IRQ2E	IRQ1E	IRQ0E
Initial value :	0	0	0	0	0	0	0	0
R/W :	—	—	R/W	R/W	R/W	R/W	R/W	R/W

IRQ5 to IRQ0 enable bits

0	IRQn interrupt is disabled
1	IRQn interrupt is enabled

Note: n = 5 to 0

**H'FFF2: IRQ Status Register IRQR: Interrupt Controller**

Bit :	7	6	5	4	3	2	1	0
	—	—	IRQ5F	IRQ4F	IRQ3F	IRQ2F	IRQ1F	IRQ0F
Initial value :	0	0	0	0	0	0	0	0
R/W :	—	—	R/(W)*	R/(W)*	R/(W)*	R/(W)*	R/(W)*	R/(W)*

IRQ5 to IRQ0 flag

0	[Clearing condition] Cleared by reading IRQnF set to 1, then writing 0 in IRQnF When IRQn interrupt exception handling is executed
1	[Setting conditions] (1) When a falling edge occurs in $\overline{\text{IRQn}}$ input while falling edge detection is set (IRQnEG = 0) (2) When a rising edge occurs in $\overline{\text{IRQn}}$ input while rising edge detection is set (IRQnEG = 0) (3) When a falling or rising edge occurs in $\overline{\text{IRQ0}}$ input while both-edge detection is set (IRQ0EG1 = 1)

Note: n = 5 to 0

Note: \* Only 0 can be written to clear the flag.

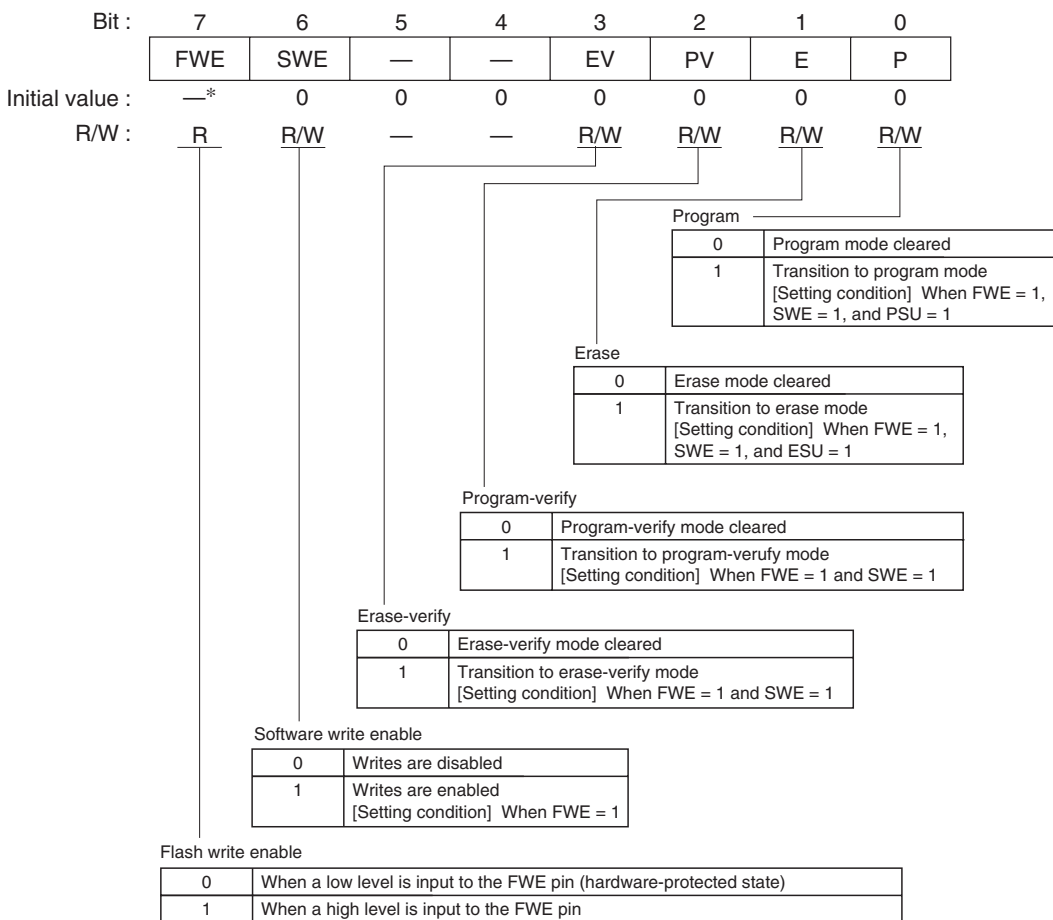
**H'FFF3: Interrupt Control Register A ICRA: Interrupt Controller****H'FFF4: Interrupt Control Register B ICRB: Interrupt Controller****H'FFF5: Interrupt Control Register C ICRC: Interrupt Controller****H'FFF6: Interrupt Control Register D ICRD: Interrupt Controller**

Bit :	7	6	5	4	3	2	1	0
	ICR7	ICR6	ICR5	ICR4	ICR3	ICR2	ICR1	ICR0
Initial value :	0	0	0	0	0	0	0	0
R/W :	R/W	R/W	R/W	R/W	R/W	R/W	R/W	R/W

Interrupt control level

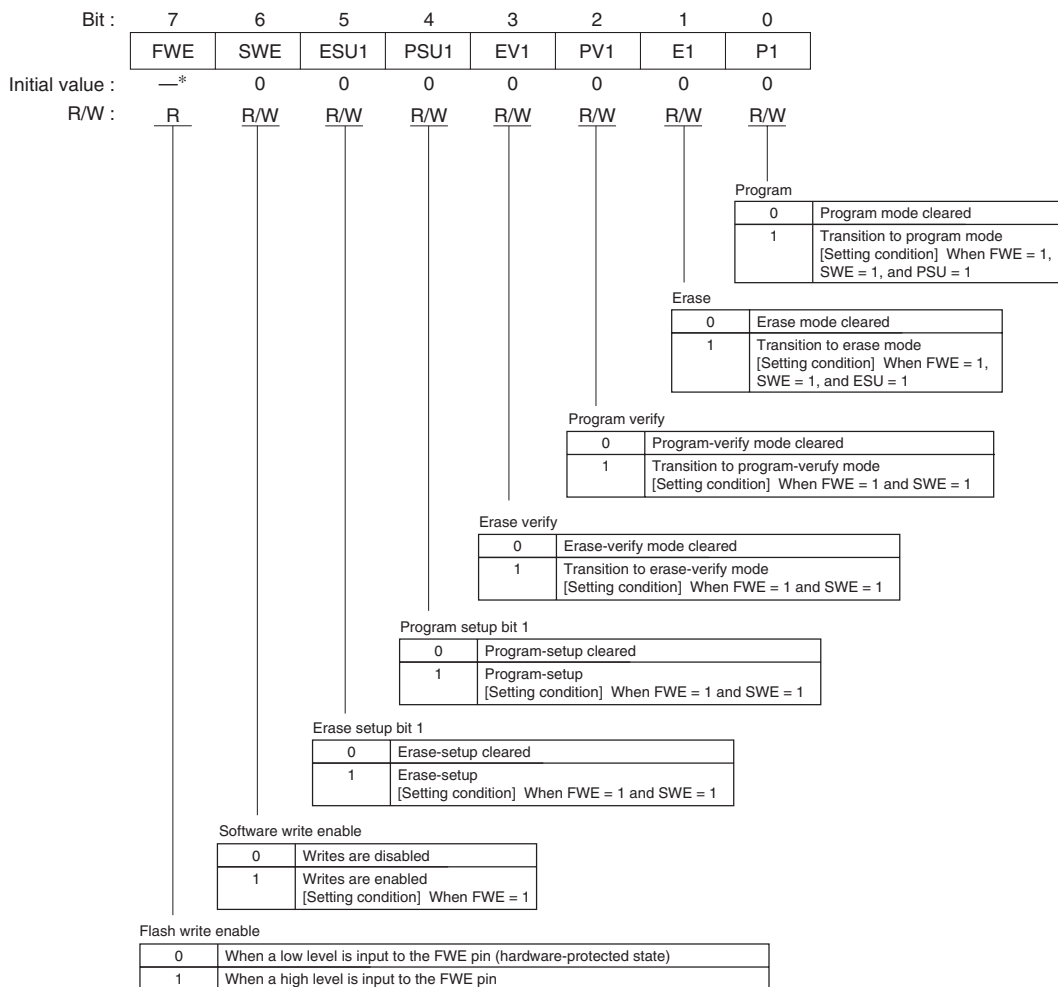
0	Corresponding interrupt source is control level 0 (non-priority)
1	Corresponding interrupt source is control level 1 (priority)

Note: n = 7 to 0

**H'FFF8: Flash Memory Control Register 1 FLMCR1:****FLASH ROM (H8S/2194 FLASH Version Only)**

Note: \* Determined by the state of the FWE pin.



**H'FFF8: Flash Memory Control Register 1 FLMCR1:****FLASH ROM (H8S/2194C FLASH Version Only)**

Note: \* Determined by the state of the FWE pin.

**H'FFF9: Flash Memory Control Register 2 FLMCR2:****FLASH ROM (H8S/2194 FLASH Version Only)**

Bit :	7	6	5	4	3	2	1	0
	FLER	—	—	—	—	—	ESU	PSU
Initial value :	0	0	0	0	0	0	0	0
R/W :	R	—	—	—	—	—	R/W	R/W

Program setup

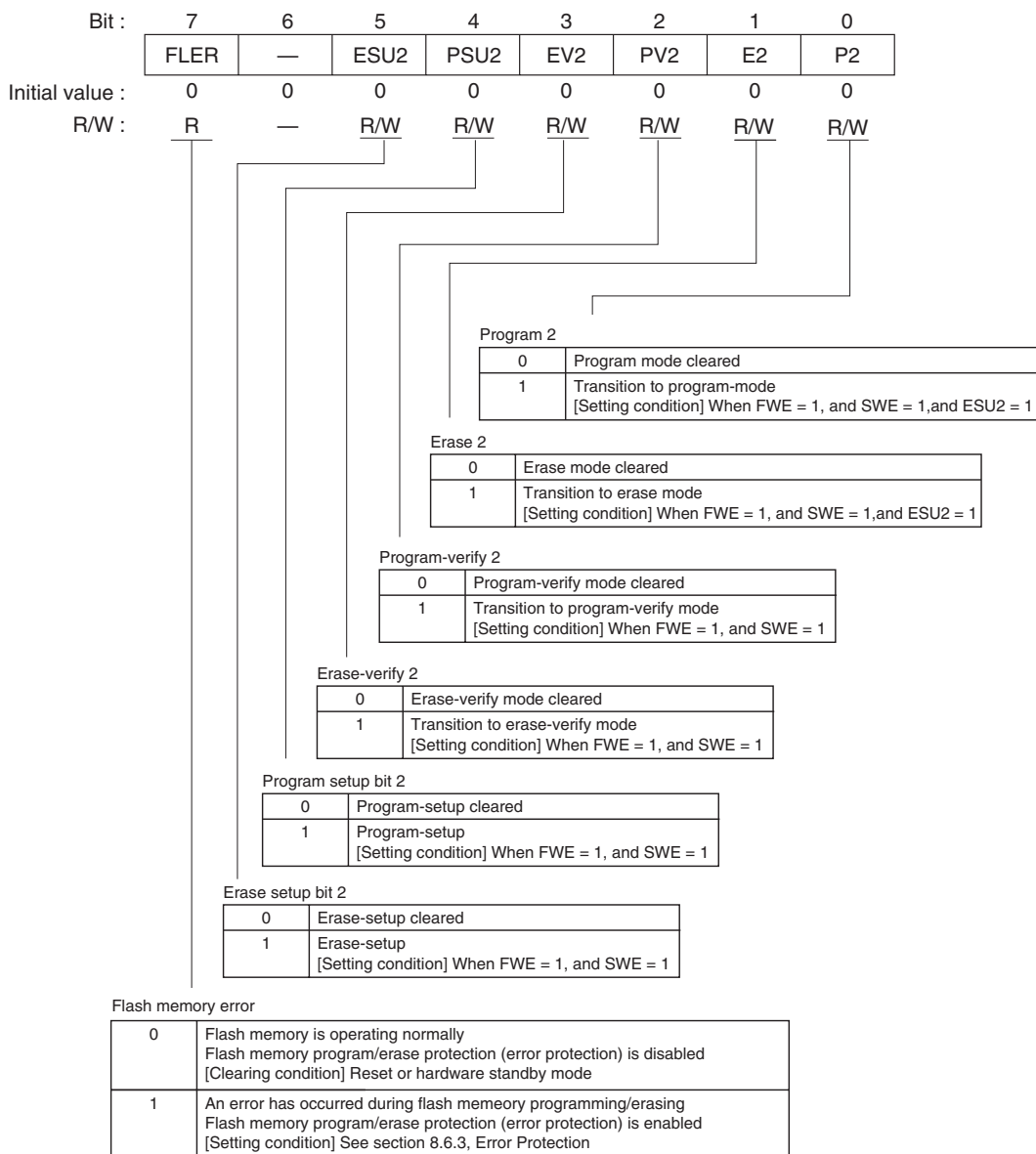
0	Program setup cleared
1	Program setup [Setting condition] When FWE = 1, and SWE = 1

Erase setup

0	Erase setup cleared
1	Erase setup [Setting condition] When FWE = 1, and SWE = 1

Flash memory error

0	Flash memory is operating normally Flash memory program/erase protection (error protection) is disabled [Clearing condition] Reset or hardware standby mode
1	An error has occurred during flash memory programming/erasing Flash memory program/erase protection (error protection) is enabled [Setting condition] See section 7.6.3, Error Protection

**H'FFF9: Flash Memory Control Register 2 FLMCR2:****FLASH ROM (H8S/2194C FLASH Version Only)**

**H'FFFA: Erase Block Select Register 1 EBR1:****FLASH ROM (H8S/2194 FLASH Version Only)**

Bit :	7	6	5	4	3	2	1	0
EBR1	—	—	—	—	—	—	EB9	EB8
Initial value :	0	0	0	0	0	0	0	0
R/W :	—	—	—	—	—	—	R/W	R/W

**H'FFFA: Erase Block Select Register 1 EBR1:****FLASH ROM (H8S/2194C FLASH Version Only)**

Bit :	7	6	5	4	3	2	1	0
EBR1	—	—	EB13	EB12	EB11	EB10	EB9	EB8
Initial value :	0	0	0	0	0	0	0	0
R/W :	—	—	R/W	R/W	R/W	R/W	R/W	R/W

**H'FFFB: Erase Block Select Register 2 EBR2:****FLASH ROM (H8S/2194 FLASH Version Only)**

Bit :	7	6	5	4	3	2	1	0
EBR2	EB7	EB6	EB5	EB4	EB3	EB2	EB1	EB0
Initial value :	0	0	0	0	0	0	0	0
R/W :	R/W	R/W	R/W	R/W	R/W	R/W	R/W	R/W

## Division of Erase Block

Block (size)	Address
128-kbyte version	
EB0 (1 kbyte)	H'000000 to H'0003FF
EB1 (1 kbyte)	H'000400 to H'0007FF
EB2 (1 kbyte)	H'000800 to H'000BFF
EB3 (1 kbyte)	H'000C00 to H'000FFF
EB4 (28 kbytes)	H'001000 to H'007FFF
EB5 (16 kbytes)	H'008000 to H'00BFFF
EB6 (8 kbytes)	H'00C000 to H'00DFFF
EB7 (8 kbytes)	H'00E000 to H'00FFFF
EB8 (32 kbytes)	H'010000 to H'017FFF
EB9 (32 kbytes)	H'018000 to H'01FFFF

**H'FFFB: Erase Block Select Register 2 EBR2:****FLASH ROM (H8S/2194C FLASH Version Only)**

Bit :	7	6	5	4	3	2	1	0
EBR2	EB7	EB6	EB5	EB4	EB3	EB2	EB1	EB0
Initial value :	0	0	0	0	0	0	0	0
R/W :	R/W	R/W	R/W	R/W	R/W	R/W	R/W	R/W

## Division of Erase Block

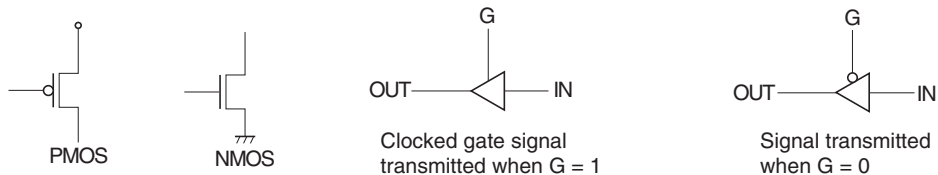
Block (size)	Address
256-kbyte version	
EB0 (1 kbyte)	H'000000 to H'0003FF
EB1 (1 kbyte)	H'000400 to H'0007FF
EB2 (1 kbyte)	H'000800 to H'000BFF
EB3 (1 kbyte)	H'000C00 to H'000FFF
EB4 (28 kbytes)	H'001000 to H'007FFF
EB5 (16 kbytes)	H'008000 to H'00BFFF
EB6 (8 kbytes)	H'00C000 to H'00DFFF
EB7 (8 kbytes)	H'00E000 to H'00FFFF
EB8 (32 kbytes)	H'010000 to H'017FFF
EB9 (32 kbytes)	H'018000 to H'01FFFF
EB10 (32 kbytes)	H'020000 to H'027FFF
EB11 (32 kbytes)	H'028000 to H'02FFFF
EB12 (32 kbytes)	H'030000 to H'037FFF
EB13 (32 kbytes)	H'038000 to H'03FFFF

## Appendix C Pin Circuit Diagrams

### C.1 Pin Circuit Diagrams

Circuit diagrams for all pins except power supply pins are shown in table C.1.

Legend



Legend:

RD: Read signal

RST: Reset signal

LPM: Power-down mode signal (1 in standby, watch, and subactive modes)

Hi-Z: High impedance

SLEEP: Sleep mode signal

Note: Numbers given for resistance values, etc., are reference values.

Table C.1 Pin Circuit Diagrams

Pin Names	Circuit Diagram	Pin States		
		At Reset	Sleep Mode	Power-Down Modes Other than Sleep Mode
P00/AN0 to P07/AN7	<p>PMR0n · RD</p> <p>SCH3 to SCH0</p>	Hi-Z	Retained	Hi-Z
AN8 to ANB	<p>HCH1, HCH0</p>	Hi-Z	Retained	Hi-Z
P10/ $\overline{\text{IRQ0}}$ to P15/ $\overline{\text{IRQ5}}$ P16/IC	<p>PUR1n · <math>\overline{\text{PCR1n}}</math></p> <p>PDR1n</p> <p>PMR1n</p> <p>PCR1n</p> <p>RD</p> <p>INT</p> <p>PMR1n</p> <p>Notes: INT = <math>\overline{\text{IRQ0}}</math> to <math>\overline{\text{IRQ5}}</math>, IC n = 0 to 6</p>	Hi-Z	Retained	Pull-up MOS: OFF Subactive mode: Functions Other modes: Hi-Z

Pin Names	Circuit Diagram	Pin States		
		At Reset	Sleep Mode	Power-Down Modes Other than Sleep Mode
P17/TMOW		Hi-Z	Retained	Pull-up MOS: OFF Subactive mode: Functions Other modes: Hi-Z
P20/SI1	<p>Legend:                      RXE: Input control signal determined by SCR and SMR.</p>	Hi-Z	Retained	Pull-up MOS: OFF Subactive mode: Functions Other modes: Hi-Z  When SI1 input is selected, pin input should be fixed high or low.



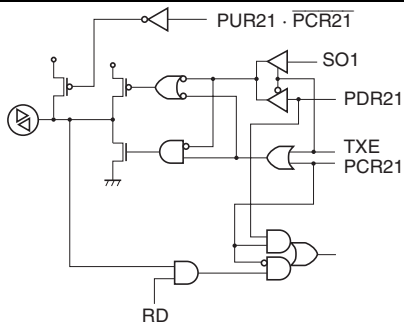
**Pin States**

**Pin Names    Circuit Diagram**

**At Reset    Sleep Mode**

**Power-Down Modes Other than Sleep Mode**

P21/SO1



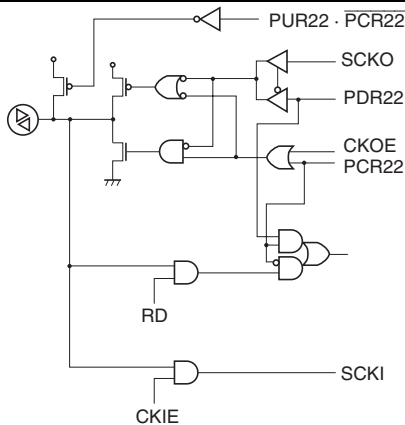
Hi-Z

Retained

Pull-up MOS:  
OFF  
Subactive mode:  
Functions  
Other modes:  
Hi-Z

Legend:  
TXE: Output control signal determined by SCR and SMR.

P22/SCK1



Hi-Z

Retained

Pull-up MOS:  
OFF  
Subactive mode:  
Functions  
Other modes:  
Hi-Z

Legend:  
SCKO: Transfer clock output  
SCKI: Transfer clock input  
CKOE: Transfer clock output control signal determined by SMR  
CKIE: Transfer clock input control signal determined by SMR and SCR

When SCK1 is set to input, pin input should be fixed high or low.



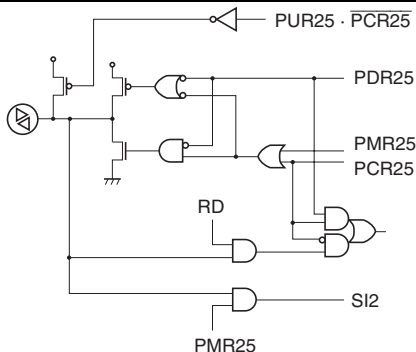
**Pin States**

**Pin Names    Circuit Diagram**

**At Reset    Sleep Mode**

**Power-Down Modes Other than Sleep Mode**

P25/SI2



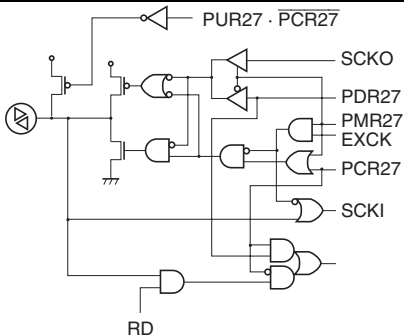
Hi-Z

Retained

Pull-up MOS: OFF  
Subactive mode: Functions  
Other modes: Hi-Z

When SI2 input is selected, pin input should be fixed high or low.

P27/SCK2



Hi-Z

Retained

Pull-up MOS: OFF  
Subactive mode: Functions  
Other modes: Hi-Z

When SCK2 is set to input, pin input should be fixed high or low.

Legend:  
SCKO: Transfer clock output  
SCKI: Transfer clock input  
EXCK: External clock input control signal determined by SMR1 or SMR2  
Note: n = 3, 6

Pin Names	Circuit Diagram	Pin States		
		At Reset	Sleep Mode	Power-Down Modes Other than Sleep Mode
P30/ $\overline{CS}$		Hi-Z	Retained	Pull-up MOS: OFF Subactive mode: Functions Other modes: Hi-Z
P31/STRB P32/PWM0 P33/PWM1 P34/PWM2 P35/PWM3 P36/BUZZ P37/TMO		Hi-Z	Retained	Pull-up MOS: OFF Subactive mode: Functions Other modes: Hi-Z
Legend: OUT: P31/STRB: SC12 strobe output P32/PWM0: 8-bit PWM0 output P33/PWM1: 8-bit PWM1 output P34/PWM2: 8-bit PWM2 output P35/PWM3: 8-bit PWM3 output P36/BUZZ: Timer J buzzer output P37/TMO: Timer J timer output Note: n = 1 to 7				



Pin Names	Circuit Diagram	Pin States		
		At Reset	Sleep Mode	Power-Down Modes Other than Sleep Mode
P47		Hi-Z	Retained	Subactive mode: Functions  Other modes: Hi-Z
P50/ADTRG	<p>Legend: TRGE: A/D trigger input control signal</p>	Hi-Z	Retained	Subactive mode: Functions  Other modes: Hi-Z  When ADTRG input is selected, pin input should be fixed high or low.
P51		Hi-Z	Retained	Subactive mode: Functions  Other modes: Hi-Z



Pin Names	Circuit Diagram	Pin States		
		At Reset	Sleep Mode	Power-Down Modes Other than Sleep Mode
P80/ EXTTRG P81/EXCAP	<p>Legend: IN = EXTTRG, EXCAP Note: n = 0, 1</p>	Hi-Z	Retained	Subactive mode: Functions  Other modes: Hi-Z
P82/SV1 P83/SV2	<p>Legend: OUT = SV1, SV2 Note: n = 2, 3</p>	Hi-Z	Retained	Subactive mode: Functions  Other modes: Hi-Z
P84 to P87	<p>Note: n = 4 to 7</p>	Hi-Z	Retained	Subactive mode: Functions  Other modes: Hi-Z
Csync	<p>Module STOP</p>	Pin input should be fixed high or low.		



Pin States

Pin Names	Circuit Diagram	Pin States		
		At Reset	Sleep Mode	Power-Down Modes Other than Sleep Mode
COMP/PS2		Hi-Z	Hi-Z	Hi-Z
When COMP input is selected, pin input should be fixed high or low.				
AUDIOFF VIDEOFF		Hi-Z	Hi-Z	Hi-Z
Legend: LPM: power-down mode signal				
CAPPWM DRMPWM		Low output	Low output	Low output
Vpulse	<p>Note: Resistance values are reference value</p>	Low output	Low output	Low output
RES		Low input (High)		(High)
MDO		—		
NMI				When $\overline{\text{NMI}}$ is not used, pin input should be fixed high or low.

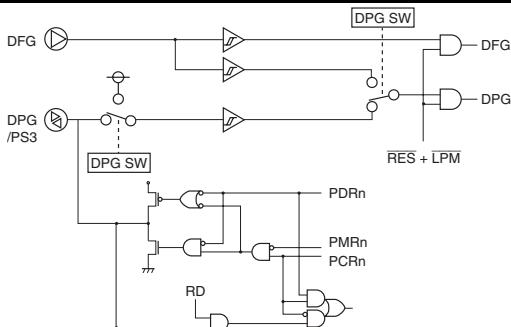
Pin Names	Circuit Diagram	Pin States		
		At Reset	Sleep Mode	Power-Down Modes Other than Sleep Mode
C.Rotary/PS0 H.Ampsw/ PS1	<p>Notes: n = 0, 1 OUT = C.Rotary, H.Ampsw</p>	Hi-Z	Hi-Z	Hi-Z
EXCTL/PS4		Hi-Z	Hi-Z	Hi-Z
CFG		---	---	---

When EXCTL input is selected, pin input should be fixed high or low.

Pin States

Pin Names    Circuit Diagram

DFG  
DPG/PS3

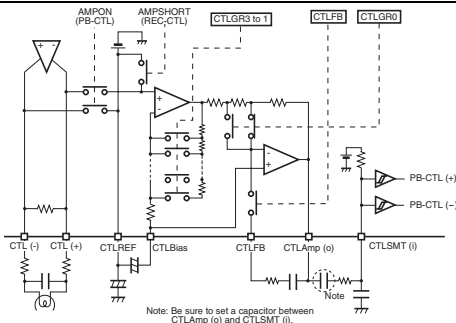


Hi-Z

Sleep Mode

Power-Down Modes Other than Sleep Mode

CTL (+)  
CTL (-)  
CTLREF  
CTLBias  
CTLFB  
CTLAmp (o)  
CTLSMT (i)

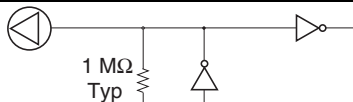


—

—

—

X2



Oscillation

Oscillation

Oscillation

X1

Note: Resistance values are reference values.

When the subclock is not used, set X1 = high and X2 = open.

OSC2



Oscillation

Oscillation

Low output

OSC1



—

—

# Appendix D Port States in the Difference Processing States

## D.1 Pin Circuit Diagrams

**Table D.1 Port States Overview**

Port	Reset	Active	Sleep	Standby	Watch	Subactive	Subsleep
P07 to P00	High imped-ance	High imped-ance	High imped-ance	High imped-ance	High imped-ance	High impedance	High impedance
P17 to P10	High imped-ance	Functions	Retained	High imped-ance	High imped-ance	Functions	Retained
P27 to P20	High imped-ance	Functions	Retained	High imped-ance	High imped-ance	Functions	Retained
P37 to P30	High imped-ance	Functions	Retained	High imped-ance	High imped-ance	Functions	Retained
P47 to P40	High imped-ance	Functions	Retained	High imped-ance	High imped-ance	Functions	Retained
P53 to P50	High imped-ance	Functions	Retained	High imped-ance	High imped-ance	Functions	Retained
P67 to P60	High imped-ance	Functions	Retained	High imped-ance	High imped-ance	Functions	Retained
P77 to P70	High imped-ance	Functions	Retained	High imped-ance	High imped-ance	Functions	Retained
P87 to P80	High imped-ance	Functions	Retained	High imped-ance	High imped-ance	Functions	Retained

## Appendix E Usage Notes

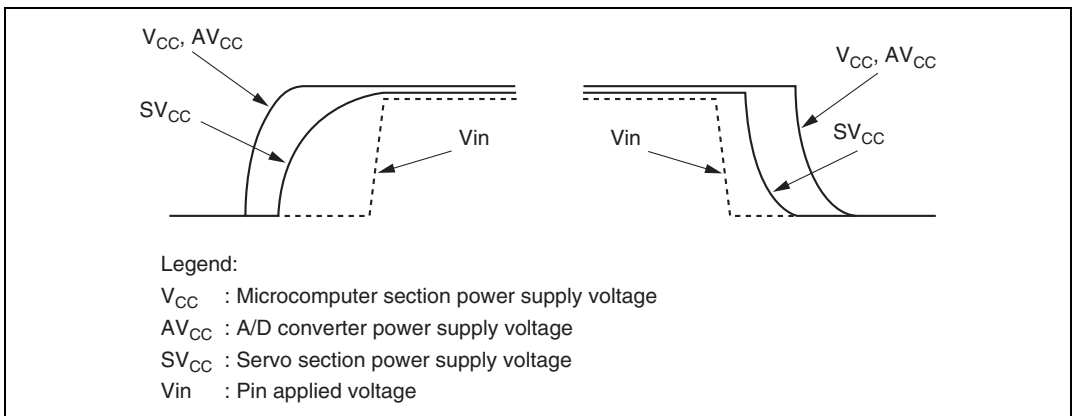
### E.1 Power Supply Rise and Fall Order

Figure E.1 shows the order in which the power supply pins rise when the chip is powered on, and the order in which they fall when the chip is powered down. If the power supply voltages cannot rise and fall simultaneously, power supply operations should be carried out in this order.

At power-on, wait until the microcomputer section power supply ( $V_{CC}$ ) has risen to the prescribed voltage, then raise the other analog power supplies.

At power-down, drop the analog power supplies first, followed by the microcomputer section power supply ( $V_{CC}$ ).

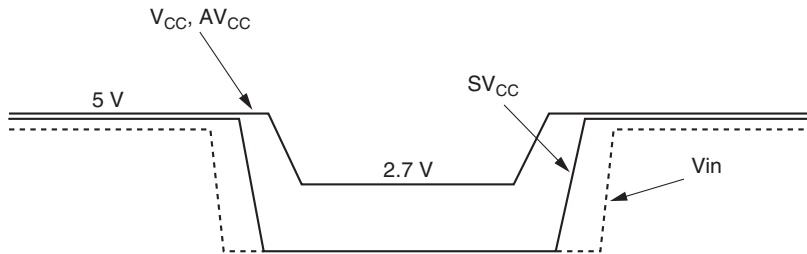
When powering up and down, ensure that the voltage applied to the pins does not exceed the respective power supply voltage.



**Figure E.1 Power Supply Rise and Fall Order**

In power-down modes (except sleep mode), the analog power supplies can be turned off to reduce current dissipation. When the microcomputer section power supply ( $V_{CC}$ ) is dropped to the backup voltage in a power-down mode, the order shown in figure E.2 should be followed. Make sure that the voltage applied to the pins does not exceed the respective power supply voltage.

The A/D converter power supply ( $AV_{CC}$ ) should be set to the same potential as the microcomputer section power supply ( $V_{CC}$ ). In all power-down modes except sleep mode,  $AV_{CC}$  is turned off inside the device. At this time, the  $AV_{CC}$  current dissipation is defined as AISTOP.



Legend:

$V_{CC}$  : Microcomputer section power supply voltage

$AV_{CC}$  : A/D converter power supply voltage

$SV_{CC}$  : Servo section power supply voltage

$V_{in}$  : Pin applied voltage

**Figure E.2 Power Supply Control in Power-Down Modes**

## E.2 Pin Handling when the High-Speed Switching Circuit for Four-Head Special Playback Is Not Used

Table E.1 shows how the C.Rotary, H.AmpSW, and COMP pins should be handled when the switching circuit for four-head special-effects playback is not used. COMP is an input pin, and the other two are output pins.

When the switching circuit for four-head special-effects playback is not used, the related pins should be handled as shown below.

**Table E.1 Pin Handling when the High-Speed Switching Circuit for Four-Head Special Playback Is Not Used**

Pin No.	Pin Name	Connection
103	C.Rotary	OPEN (output pin)*
104	H.AMP SW	OPEN (output pin)*
105	COMP	$V_{SS}$

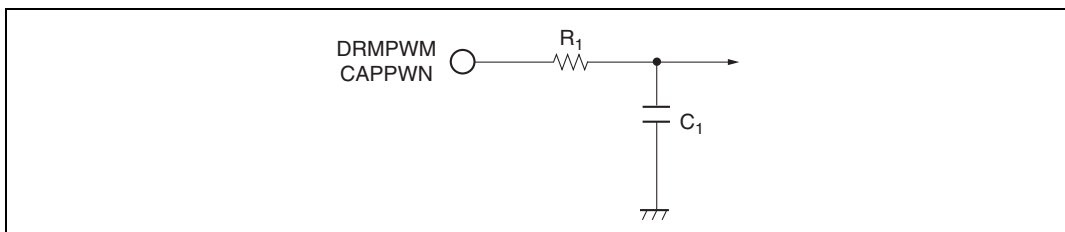
Note: \* Output depends on the special-effects control register (CHCR) value. If the initial value is used, the output is low-level.

## E.3 Sample External Circuits

Examples of external circuits for the servo section, and sync signal detection circuit are shown in figures E.3, E.4.

### (1) Servo Section

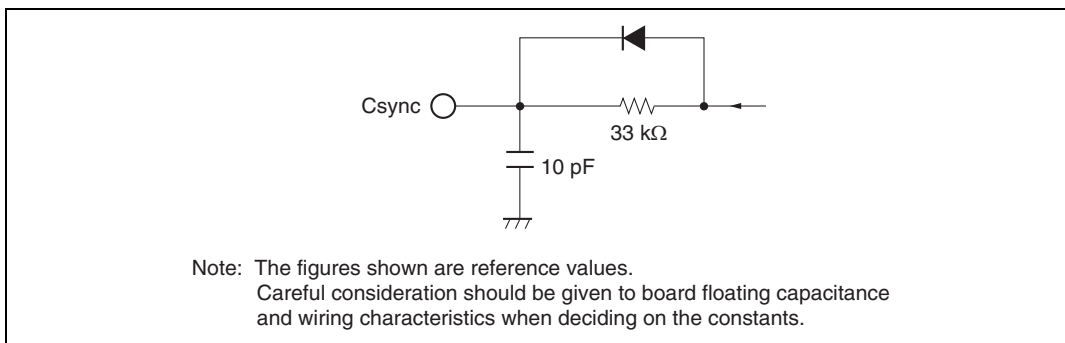
An example of the external circuit for the DRMPWM output and CAPPWM output pins is shown in figure E.3.



**Figure E.3 Sample External Circuit for Servo Section**

### (2) Sync Signal Detection Circuit Section

Figure E.4 shows an example of the external circuit for the sync signal detection circuit section.



**Figure E.4 Example of External Circuit for Sync Signal Detection Circuit Section**

## Appendix F List of Product Codes

**Table F.1 Product Codes List of H8S/2194 Group and H8S/2194C Group**

Product Type			Part No.	Mark Code	Package (Package Code)
H8S/2194 Group	H8S/2194	Mask ROM version	HD6432194	HD6432194 (***)F	112-pin QFP (FP-112)
		F-ZTAT version	HD64F2194	HD64F2194F	112-pin QFP (FP-112)
	H8S/2193	Mask ROM version	HD6432193	HD6432193 (***)F	112-pin QFP (FP-112)
	H8S/2192	Mask ROM version	HD6432192	HD6432192 (***)F	112-pin QFP (FP-112)
	H8S/2191	Mask ROM version	HD6432191	HD6432191 (***)F	112-pin QFP (FP-112)
H8S/2194C Group	H8S/2194C	Mask ROM version	HD6432194C	HD6432194C (***)F	112-pin QFP (FP-112)
		F-ZTAT version	HD64F2194C	HD64F2194CF	112-pin QFP (FP-112)
	H8S/2194B	Mask ROM version	HD6432194B	HD6432194B (***)F	112-pin QFP (FP-112)
	H8S/2194A	Mask ROM version	HD6432194A	HD6432194A (***)F	112-pin QFP (FP-112)

Note: (\*\*\*) is the ROM code.







---

**Renesas 16-Bit Single-Chip Microcomputer  
Hardware Manual  
H8S/2194 Group, H8S/2194C Group,  
H8S/2194 F-ZTAT™, H8S/2194C F-ZTAT™**

Publication Date: 1st Edition, November 1998

Rev.3.00, January 10, 2007

Published by: Sales Strategic Planning Div.  
Renesas Technology Corp.

Edited by: Customer Support Department  
Global Strategic Communication Div.  
Renesas Solutions Corp.

Renesas Technology Corp. Sales Strategic Planning Div. Nippon Bldg., 2-6-2, Ohte-machi, Chiyoda-ku, Tokyo 100-0004, Japan

---



**RENESAS SALES OFFICES**

<http://www.renesas.com>

---

Refer to "<http://www.renesas.com/en/network>" for the latest and detailed information.

**Renesas Technology America, Inc.**

450 Holger Way, San Jose, CA 95134-1368, U.S.A  
Tel: <1> (408) 382-7500, Fax: <1> (408) 382-7501

**Renesas Technology Europe Limited**

Dukes Meadow, Millboard Road, Bourne End, Buckinghamshire, SL8 5FH, U.K.  
Tel: <44> (1628) 585-100, Fax: <44> (1628) 585-900

**Renesas Technology (Shanghai) Co., Ltd.**

Unit 204, 205, AZIACenter, No.1233 Lujiazui Ring Rd, Pudong District, Shanghai, China 200120  
Tel: <86> (21) 5877-1818, Fax: <86> (21) 6887-7898

**Renesas Technology Hong Kong Ltd.**

7th Floor, North Tower, World Finance Centre, Harbour City, 1 Canton Road, Tsimshatsui, Kowloon, Hong Kong  
Tel: <852> 2265-6688, Fax: <852> 2730-6071

**Renesas Technology Taiwan Co., Ltd.**

10th Floor, No.99, Fushing North Road, Taipei, Taiwan  
Tel: <886> (2) 2715-2888, Fax: <886> (2) 2713-2999

**Renesas Technology Singapore Pte. Ltd.**

1 Harbour Front Avenue, #06-10, Keppel Bay Tower, Singapore 098632  
Tel: <65> 6213-0200, Fax: <65> 6278-8001

**Renesas Technology Korea Co., Ltd.**

Kukje Center Bldg. 18th Fl., 191, 2-ka, Hangang-ro, Yongsan-ku, Seoul 140-702, Korea  
Tel: <82> (2) 796-3115, Fax: <82> (2) 796-2145

**Renesas Technology Malaysia Sdn. Bhd**

Unit 906, Block B, Menara Amcorp, Amcorp Trade Centre, No.18, Jalan Persiaran Barat, 46050 Petaling Jaya, Selangor Darul Ehsan, Malaysia  
Tel: <603> 7955-9390, Fax: <603> 7955-9510





H8S/2194 Group, H8S/2194C Group,  
H8S/2194 F-ZTAT™, H8S/2194C F-ZTAT™  
Hardware Manual



Renesas Technology Corp.

2-6-2, Ote-machi, Chiyoda-ku, Tokyo, 100-0004, Japan