

HA16150T/P

High-Speed Current Mode Push-Pull PWM Control IC

REJ03F0146-0300

Rev.3.00

Jan 30, 2007

Description

The HA16150 is a high-speed current mode PWM control IC with push-pull dual outputs, suitable for high-reliability, high-efficiency, high-mounting-density isolated DC-DC converter and high-output AC-DC converter control.

The HA16150 can be used in various applications, including push-pull converters and half-bridge, double-forward, and single-forward applications.

The HA16150 incorporates 180-degree phase-inverted push-pull dual outputs, and directly drives a power MOS FET. Operation at a maximum of 1 MHz is possible on an oscillator reference frequency.

The package lineup comprises an ultra-thin surface-mount TSSOP-16 suitable for slim communication system modules, and a general-purpose insertion DILP-6 suitable for characteristics evaluation.

Features

<Maximum Ratings>

- Supply voltage V_{cc} : 20 V
- Peak output current I_{pk-out} : ± 1.0 A
- Operating junction temperature T_{jopr} : -40°C to $+125^{\circ}\text{C}$

<Electrical Characteristics>

- VREF output voltage V_{REF} : $5.0\text{ V} \pm 1\%$
- UVLO start threshold V_H : $9.3\text{ V} \pm 0.7\text{ V}$
- UVLO shutdown threshold V_L : $8.3\text{ V} \pm 0.7\text{ V}$
- Operating current I_{cc} : 4 mA typ.
- Standby current I_s : 150 μA typ.

<Functions>

- Soft start (one external timing capacitance)
- Remote on/off control
- Independent dead band time adjustment
- Current limiter adjustment (set drooping characteristic adjustment)
- Push-pull/single-end output switching
- Package lineup: TSSOP-16/DILP-16

Pin Arrangement

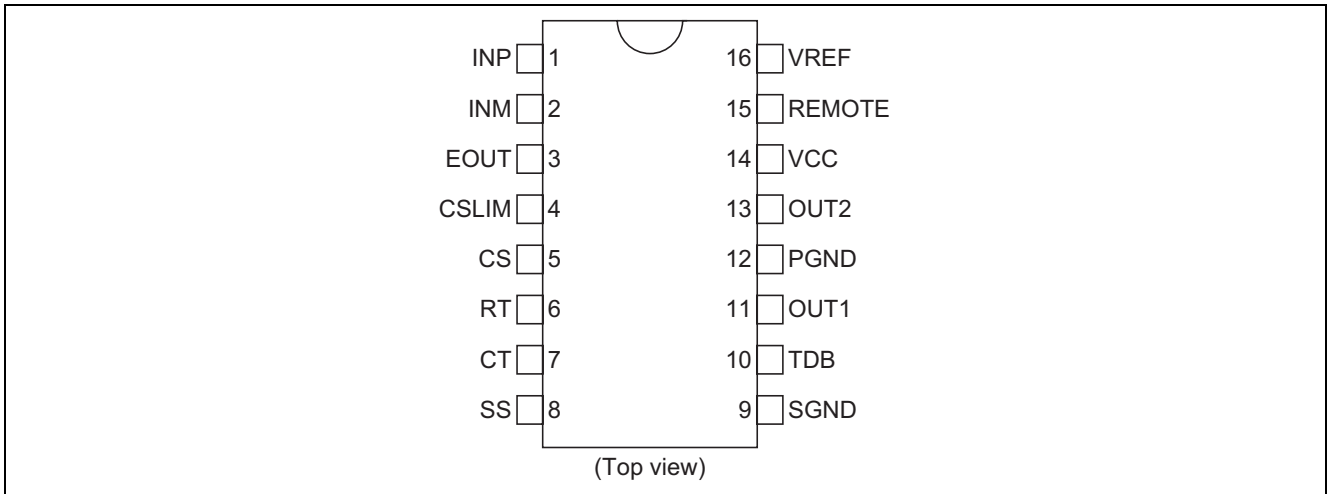

Pin Functions

Pin No.	Pin Name	Pin Functions
1	INP	Error amplifier non-inverted (+) input
2	INM	Error amplifier inverted (-) input
3	EOUT	Error amplifier output
4	CSLIM	Current limiter level adjustment
5	CS	Current sense signal input
6	RT	Operating frequency setting resistance connection
7	CT	Operating frequency setting capacitance connection
8	SS	Soft start time setting timing capacitance connection
9	SGND	Small signal system ground
10	TDB	Dead band time setting timing capacitance connection
11	OUT1	Power MOS FET driver output 1
12	PGND	Power system ground
13	OUT2	Power MOS FET driver output 2
14	VCC	Supply voltage
15	REMOTE	Remote on/off control
16	VREF	Reference voltage

Block Diagram

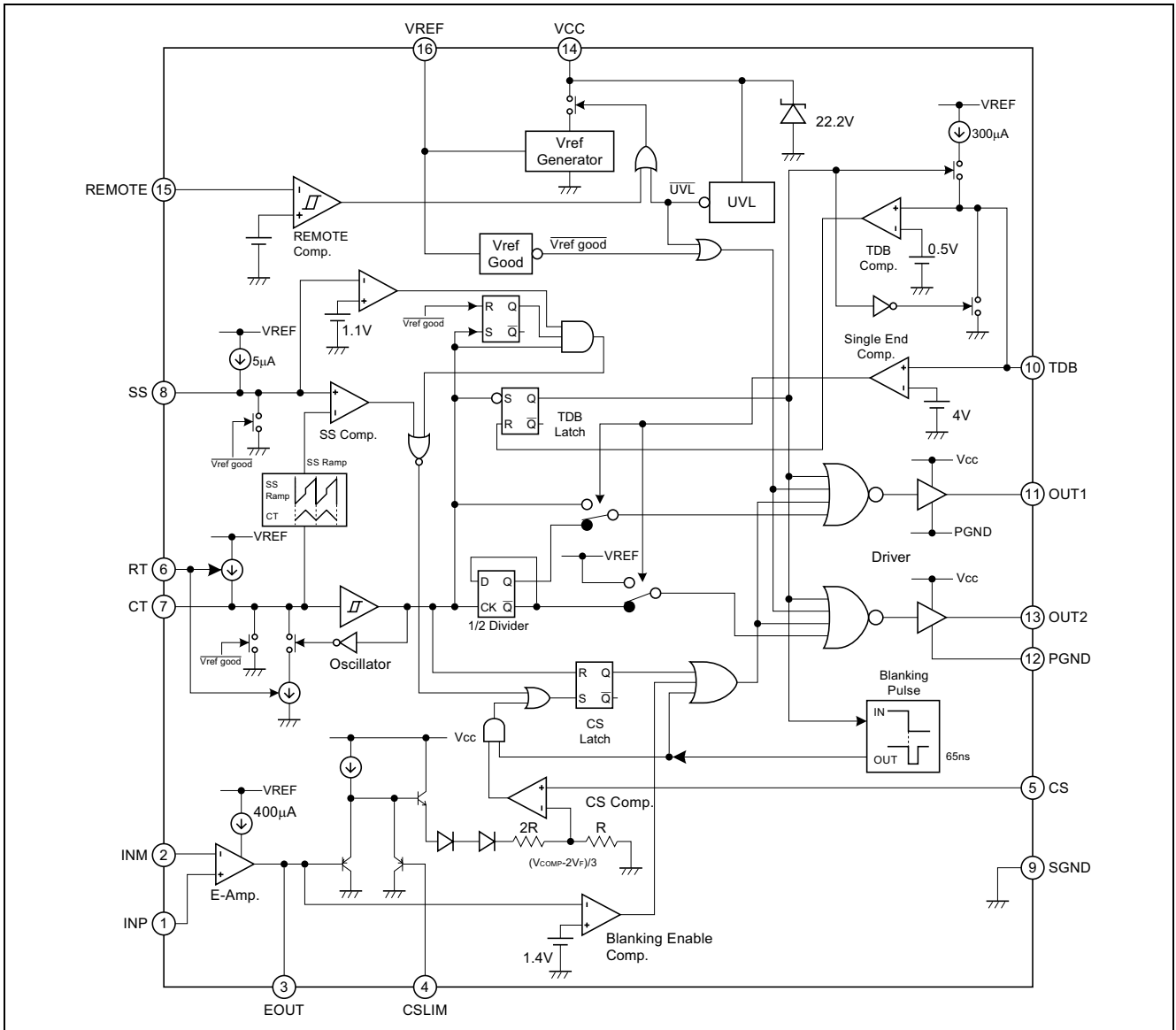

Absolute Maximum Ratings

(Ta = 25°C)

Item	Symbol	Ratings	Unit	Note
Power supply voltage	Vcc	20	V	
OUT1 output current (peak)	Ipk-out1	±1.0	A	3
OUT2 output current (peak)	Ipk-out2	±1.0	A	3
OUT1 output current (DC)	Idc-out1	±0.1	A	
OUT2 output current (DC)	Idc-out2	±0.1	A	
OUT1 output voltage	Vout1	-0.3 to Vcc	V	
OUT2 output voltage	Vout2	-0.3 to Vcc	V	
INM pin voltage	Vinm	-0.3 to Vcc	V	
REMOTE pin voltage	Vremote	-0.3 to Vcc	V	
REMOTE pin current	Iremote	+0.2	mA	
INP pin voltage	Vinp	-0.3 to Vcc	V	
SS pin voltage	Vss	-0.3 to Vref	V	
RT pin voltage	Vrt	-0.3 to Vref	V	
RT pin current	Irt	-0.2	mA	
CT pin voltage	Vct	-0.3 to Vref	V	
CSLIM pin voltage	Vcslim	-0.3 to Vref	V	
EOUT pin voltage	Veout	-0.3 to Vref	V	
VREF pin voltage	Vref	-0.3 to Vref	V	
TDB pin voltage	Vtdb	-0.3 to Vref	V	
CS pin voltage	Vcs	-0.3 to Vref	V	
Operating junction temperature	Tj-opr	-40 to +125	°C	4
Storage temperature	Tstg	-55 to +150	°C	

- Notes: 1. Rated voltages are with reference to the GND (SGND, PGND) pin.
 2. For rated currents, inflow to the IC is indicated by (+), and outflow by (-).
 3. Shows the transient current when driving a capacitive load.
 4. HA16150T (TSSOP): $\theta_{ja} = 250^{\circ}\text{C/W}$
 This value is based on actual measurements on a 110% wiring density
 glass epoxy circuit board (55 mm × 45 mm × 1.6 mm).
 HA16150P (DILP): $\theta_{ja} = 124^{\circ}\text{C/W}$

Electrical Characteristics

(Ta = 25°C, Vcc = 12 V, Fosc = 100 kHz)

	Item	Symbol	Min	Typ	Max	Unit	Test Conditions
Supply	Start threshold	VH	8.6	9.3	10.0	V	
	Shutdown threshold	VL	7.6	8.3	9.0	V	
	UVLO hysteresis	dV _{UVL}	0.7	1.0	1.3	V	
	Start-up current	I _s	100	150	250	μA	V _{cc} = 8V
	Operating current	I _{cc}	–	4	6	mA	V _{inm} = 1.0V, V _{inp} = 1.25V, V _{cs} = 0V
	Vcc zenner shunt voltage	V _z	21.2	22.2	23.2	V	I _{cc} = 10mA
	Vz temperature stability	dV _z /dT _a	–	4.5	–	mV/°C	I _{cc} = 10mA * ¹
VREF	Output voltage	V _{ref}	4.95	5.0	5.05	V	I _{ref} = –1mA
	Line regulation	V _{ref-line}	–	5	20	mV	V _{cc} = 11V to 18V
	Load regulation	V _{ref-load}	–	5	20	mV	I _{ref} = –1mA to –20mA
	Temperature stability	dV _{ref} /dT _a	–	80	–	ppm/°C	T _a = –40 to 125°C
Oscillator	Oscillator frequency	f _{osc}	88	100	112	kHz	Measured at OUT1 and OUT2 RT = 27kΩ, CT = 1000pF
	Temperature stability	df _{osc} /dT _a	–	±0.1	–	%/°C	T _a = –40 to 125°C * ¹
PWM Comparator	High voltage	V _{th}	–	3.0	–	V	DC * ¹
	Low voltage	V _{tl}	–	2.0	–	V	DC * ¹
	Differential voltage	dV _t	–	1.0	–	V	DC * ¹
Error amplifier	Input bias current	I _{fb}	–1	–	+1	μA	
	Open loop gain	A _v	–	70	–	dB	f = 1.0kHz * ¹
	EOUT sink current	I _{snk-eout}	–	3.0	–	mA	V _{eout} = 1.1V * ¹
	EOUT source current	I _{src-eout}	–	–0.4	–	mA	V _{eout} = 3.0V * ¹
	Low voltage	V _{ol-eout}	–	0.8	1.1	V	EOUT : Open
	High voltage	V _{oh-eout}	4.7	5.0	–	V	EOUT : Open
Current sense	Voltage gain	A _{vcs}	2.85	3.00	3.15	V/V	
	Delay to output	t _{d-cs}	–	150	230	ns	
	Leading edge blanking time	t _{bl}	–	65	–	ns	* ¹
	Leading edge blanking disable voltage	V _{bl-off}	1.3	1.4	1.5	V	Measured pin : EOUT
Remote	On threshold voltage	V _{on}	1.40	–	–	V	* ¹
	Off threshold voltage	V _{off}	–	–	3.00	V	* ¹
	Sink current	I _{remote}	60	90	120	μA	V _{remote} = 4V
Soft start	Source current	I _{ss}	–7.0	–5.0	–3.0	μA	V _{ss} = 1V

Note: 1. Reference values for design.

Electrical Characteristics (cont.)

(Ta = 25°C, Vcc = 12 V, Fosc = 100 kHz)

	Item	Symbol	Min	Typ	Max	Unit	Test Conditions
OUT1	Minimum duty cycle	Dmin-out1	–	–	0	%	Veout = 0V
	Maximum duty cycle	Dmax-out1	48	49	–	%	TDB : OPEN
	Rise time	tr-out1	–	30	65	ns	CL = 1000pF
	Fall time	tf-out1	–	30	65	ns	CL = 1000pF
	Low voltage	Vol1-out1	–	0.05	0.2	V	Iout = 20mA
		Vol2-out1	–	0.5	2.0	V	Iout = 200mA (pulse)
	High voltage	Voh1-out1	11.5	11.9	–	V	Iout = –20mA
Voh2-out1		10.0	11.0	–	V	Iout = –200mA (pulse)	
OUT2	Minimum duty cycle	Dmin-out2	–	–	0	%	Veout = 0V
	Maximum duty cycle	Dmax-out2	48	49	–	%	TDB : OPEN
	Rise time	tr-out2	–	30	65	ns	CL = 1000pF
	Fall time	tf-out2	–	30	65	ns	CL = 1000pF
	Low voltage	Vol1-out2	–	0.05	0.2	V	Iout = 20mA
		Vol2-out2	–	0.5	2.0	V	Iout = 200mA (pulse)
	High voltage	Voh1-out2	11.5	11.9	–	V	Iout = –20mA
Voh2-out2		10.0	11.0	–	V	Iout = –200mA (pulse)	
Dead-band time	Dead-band time	tdb0	–	60	–	ns	TDB : OPEN *1
		tdb	–	140	–	ns	Ctdb = 47pF *1

Note: 1. Reference values for design.

Timing Diagram

1. Start-up Timing

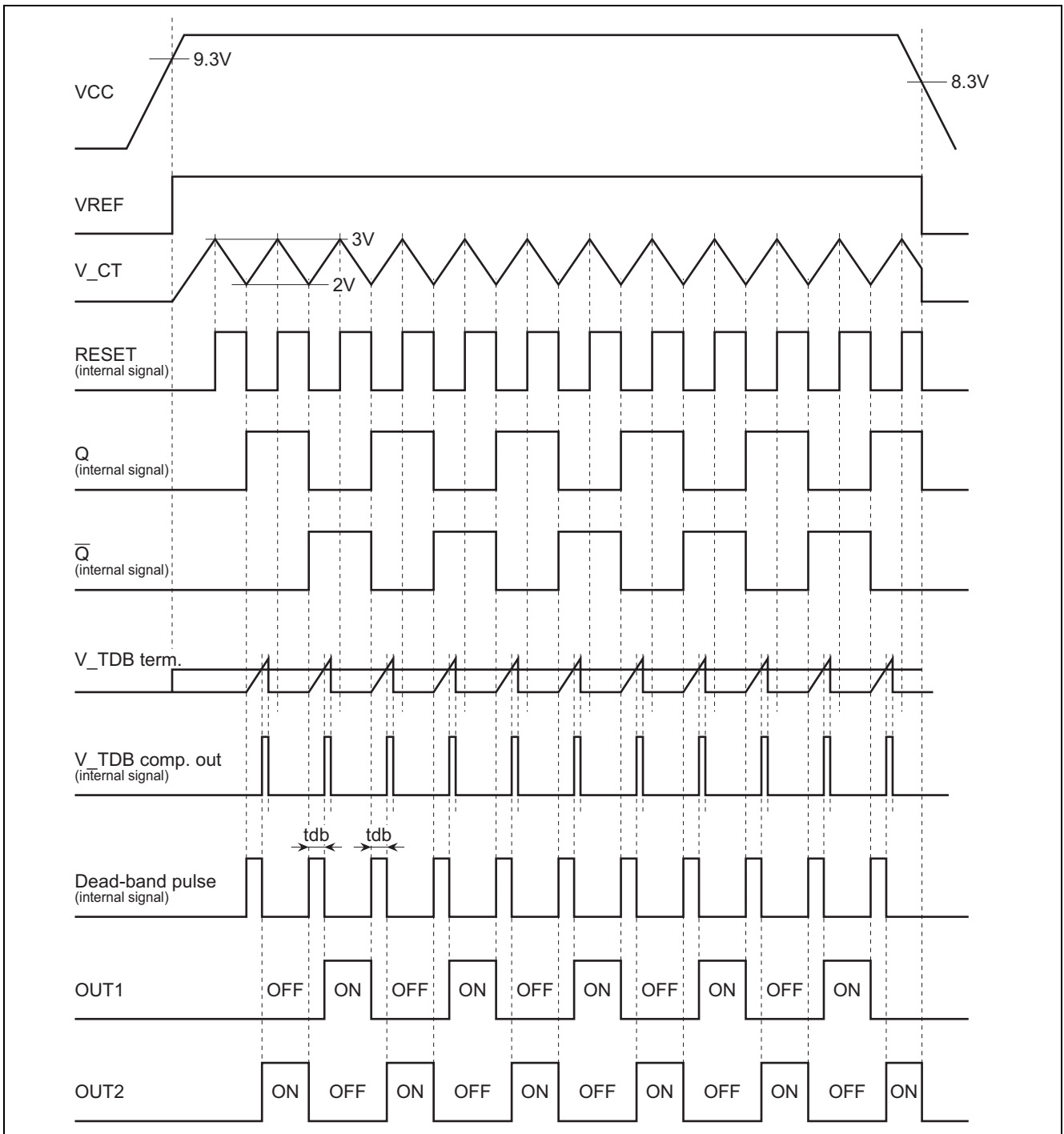

2. Current Sense

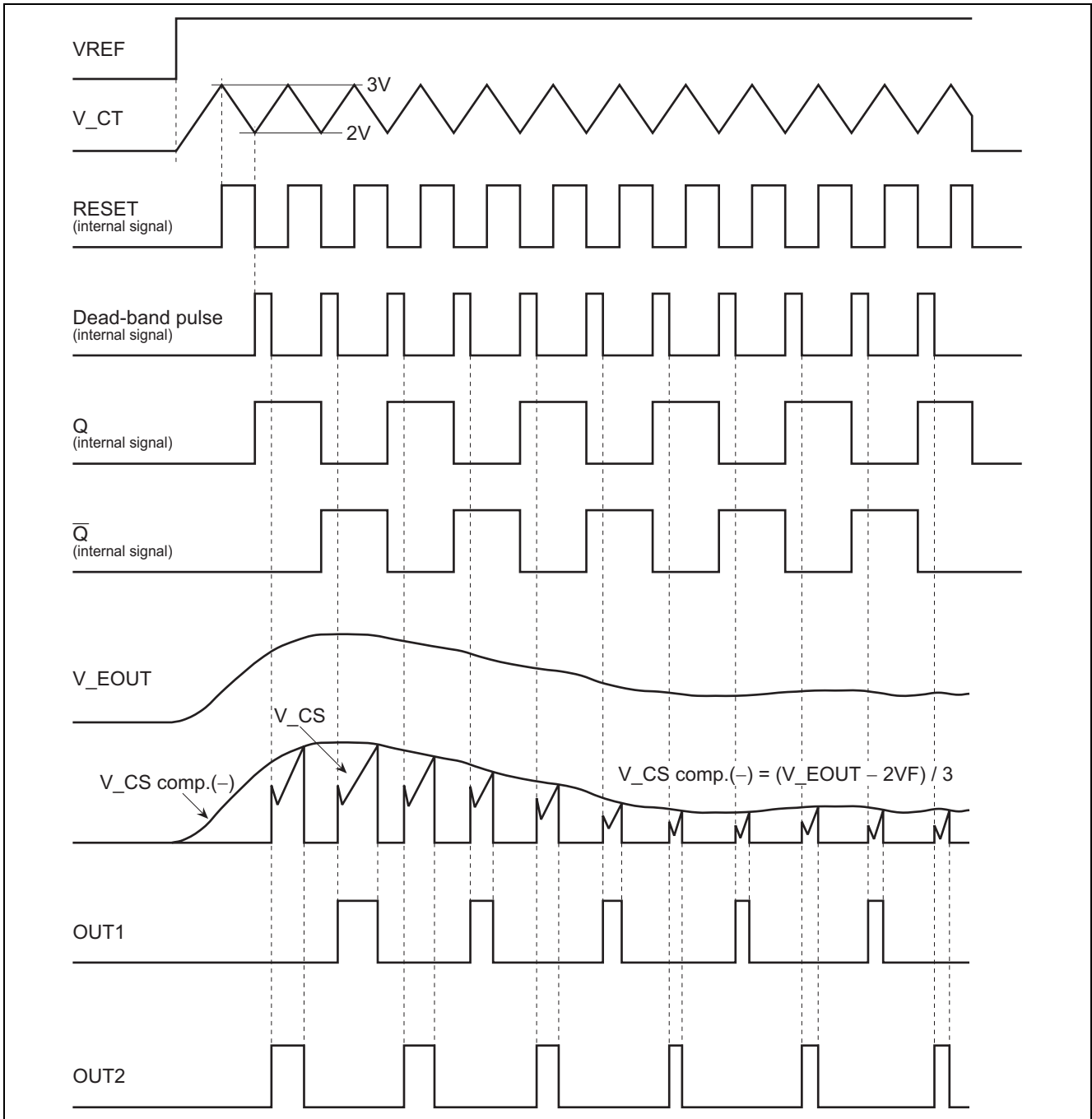

3. Soft Start

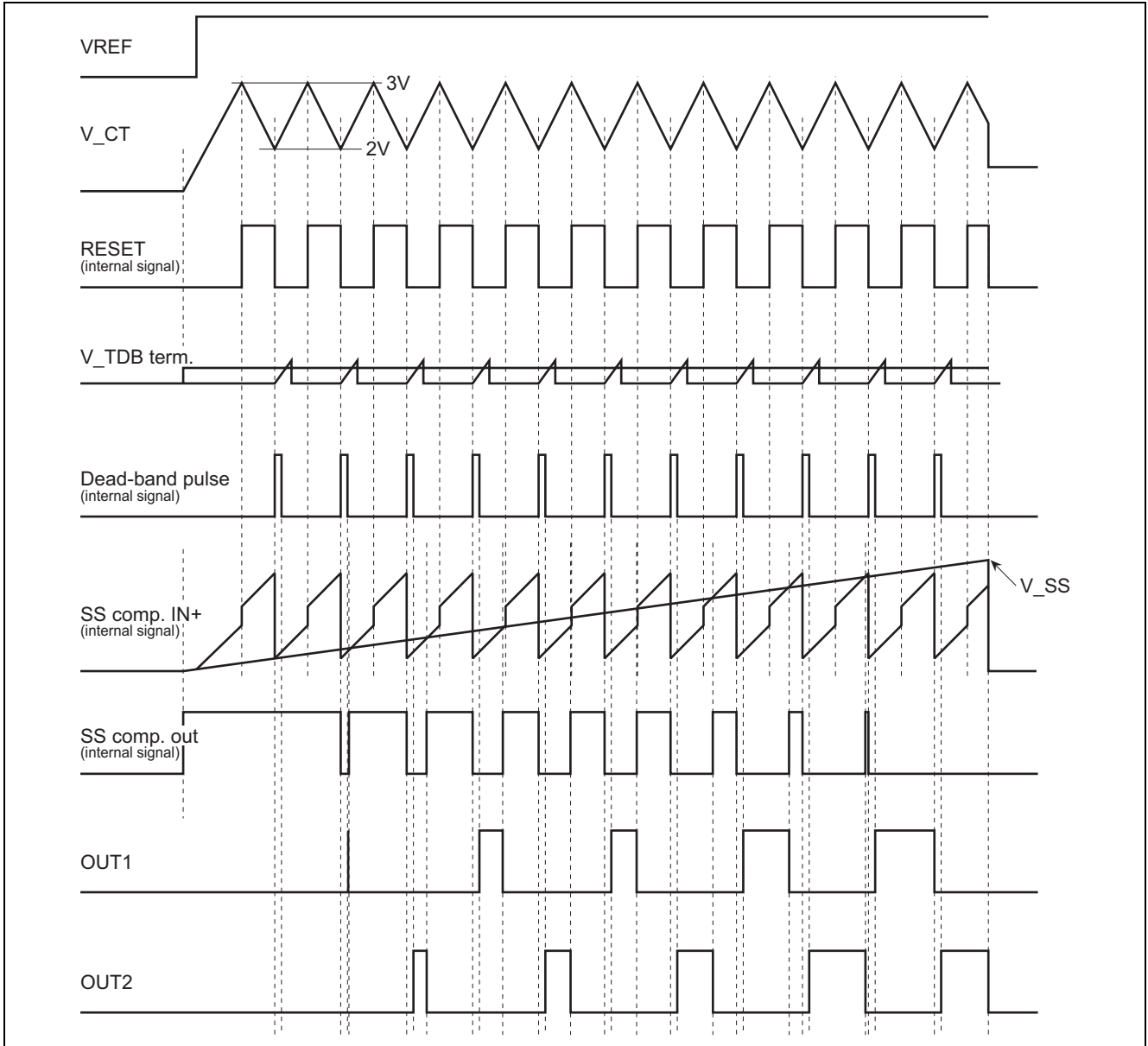

4. Leading Edge Blanking

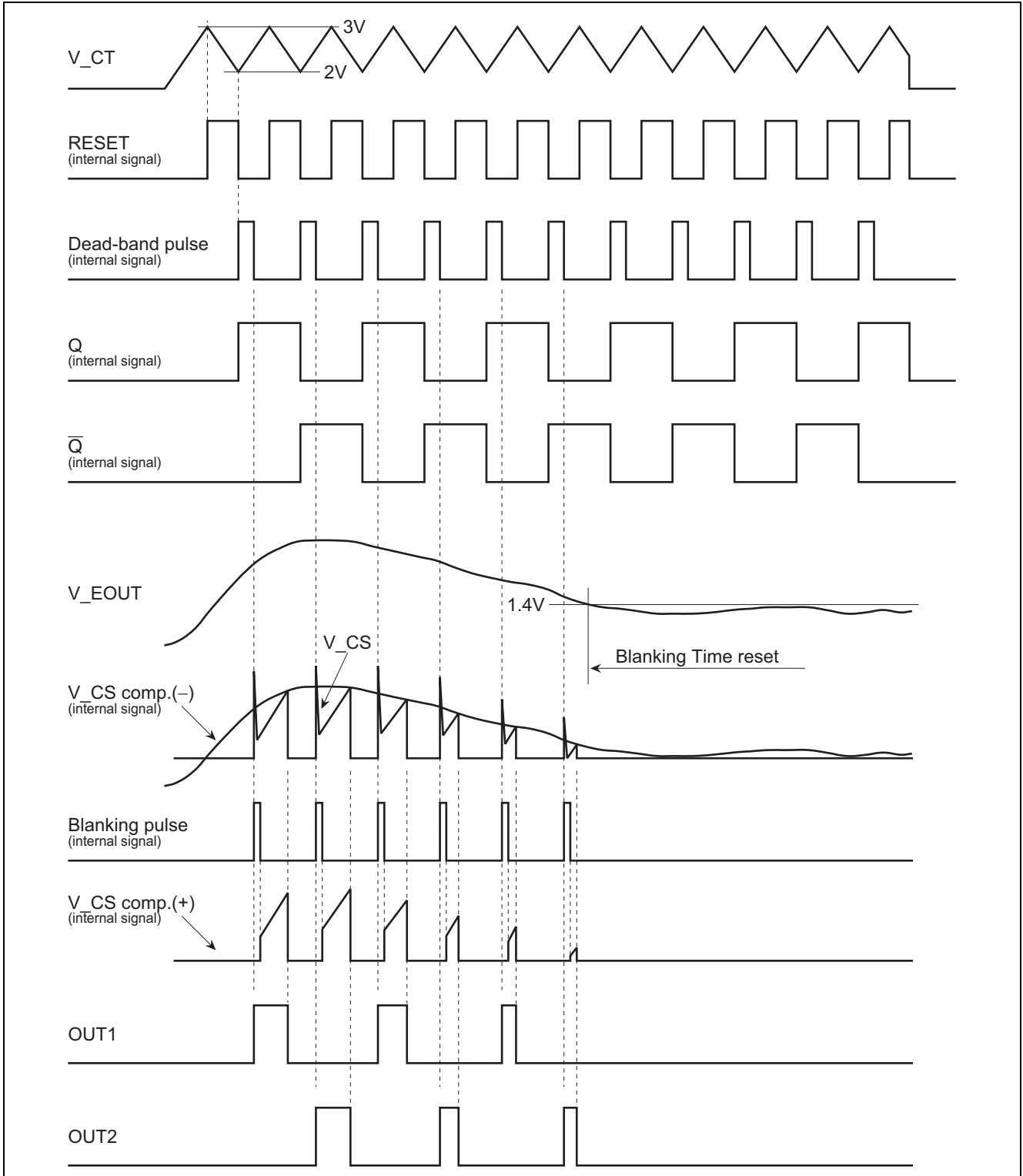

5. Push-Pull/Single-End Switching

(1) Push-pull operation: Leave the TDB pin open or connect a capacitance to GND

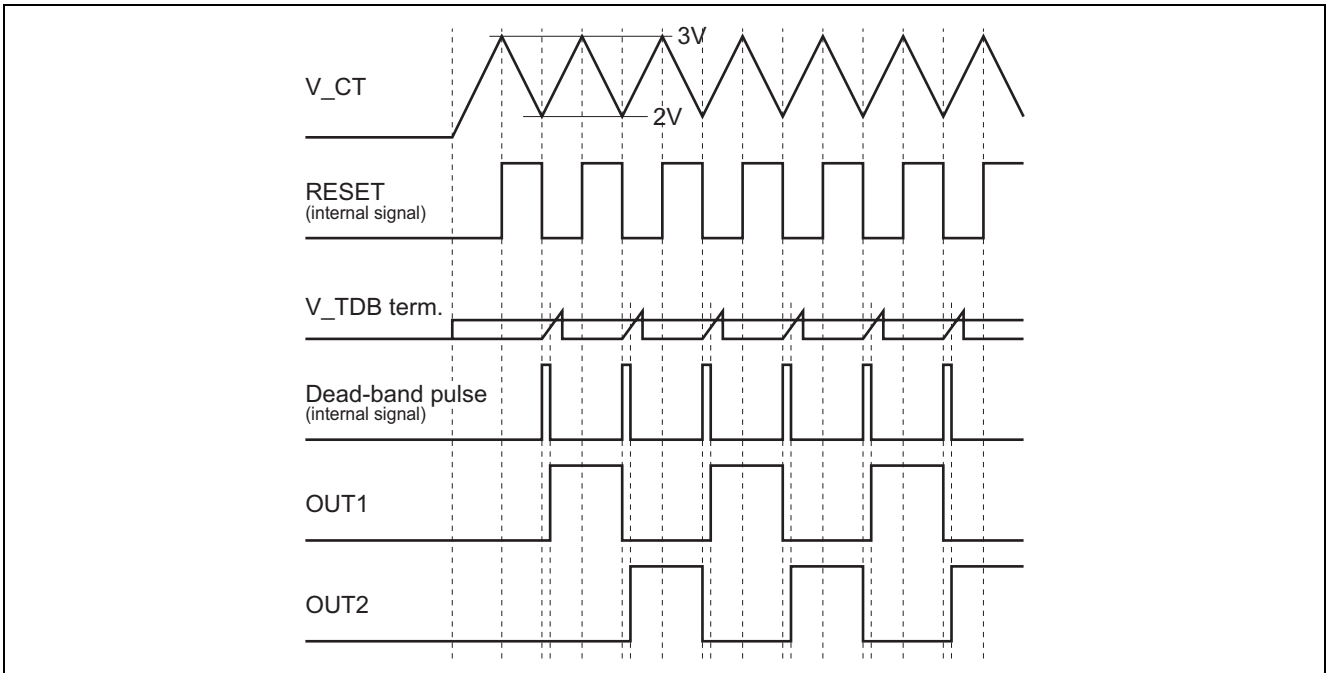

(2) Single-end operation: Perform pull-up connection of the TDB pin to the VREF pin

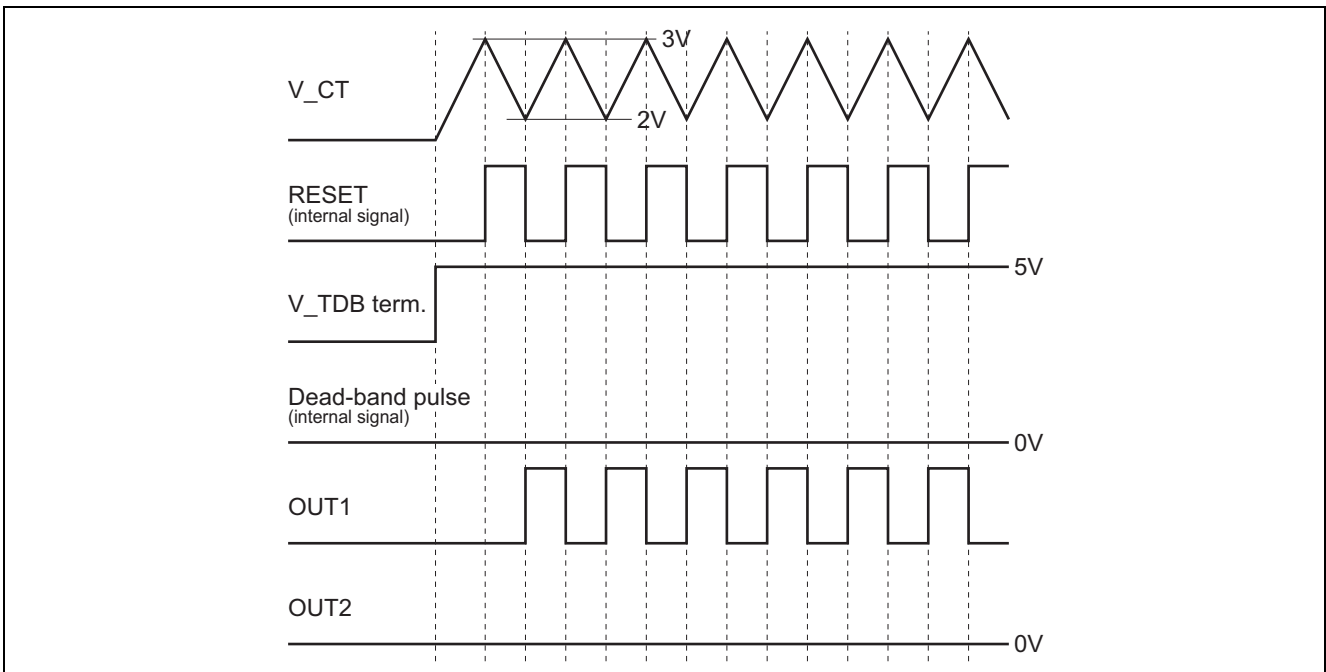

Functional Description

1. UVL Circuit

The UVL circuit monitors the Vcc voltage and halts operation of the IC in the event of a low voltage.

The voltage for detecting Vcc has a hysteresis characteristic, with 9.3 V as the start threshold and 8.3 V as the shutdown threshold.

When the IC has been halted by the UVL circuit, control is performed to fix driver circuit output low, halt VREF output and the oscillator, and reset the soft start circuit.

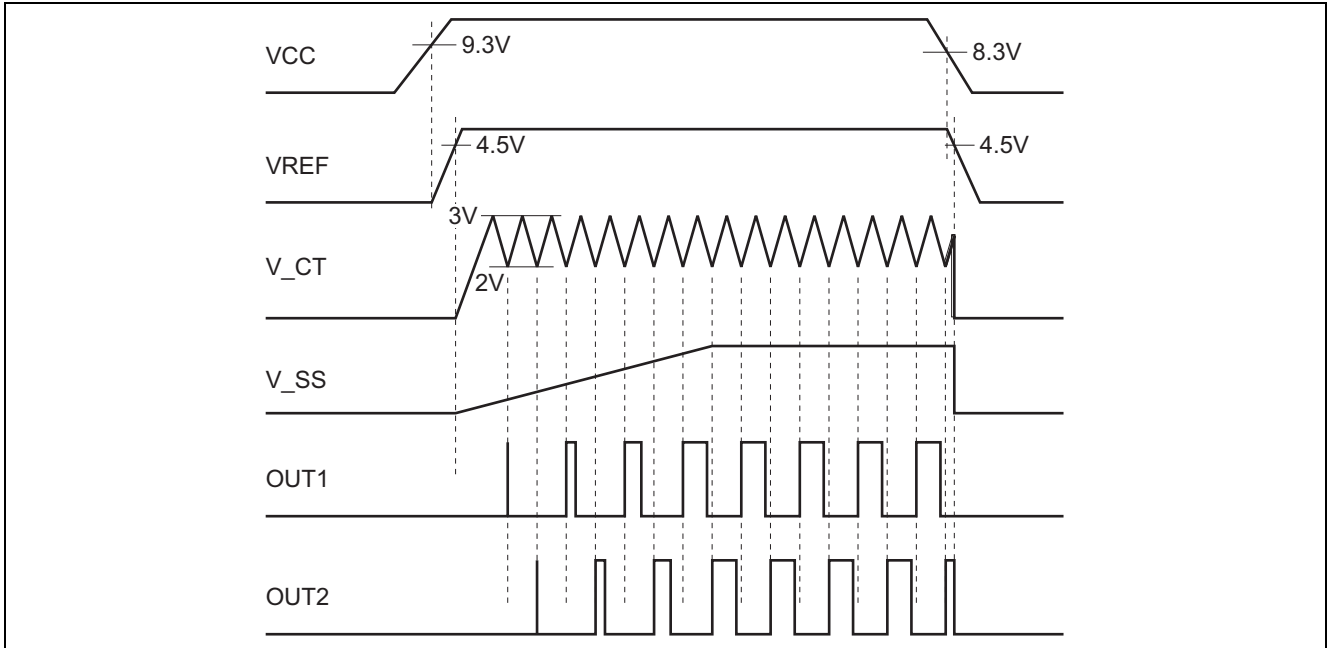

Figure 1

2. Remote ON/OFF Circuit

A remote on/off control function is incorporated, enabling the IC to be halted without cutting the supply voltage by pulling the REMOTE pin up to 3.0 V or higher.

This function halts VREF output and driver output.

At this time the IC enters Remote-OFF mode and IC current dissipation can be decreased. This function can thus be used for power management, etc.

When remote off control is performed, the soft start circuit is also reset, and therefore a soft start is effected when restarting, preventing overshoot.

However, when restarting by the remote on control function before the SS pin is completely discharged, soft start operation may not be performed normally. In such a case, add a circuit to pull the SS pin out in conjunction with a remote off signal.

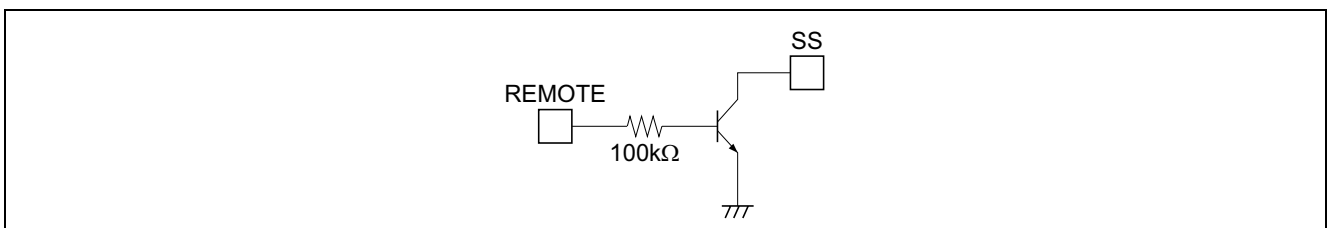

Figure 2 Example of Circuit to Pull out SS Pin

If the remote on/off control function is not used, the REMOTE pin should be permanently pulled down to GND with a resistance of about 100 kΩ.

The remote on/off control function halts only reference voltage. Other functions will be stopped when the reference voltage is below 4.5 V (typ.). Large stabilizing capacitance of the VREF pin results in a difference between the timing of remote off signal and the timing to stop the IC

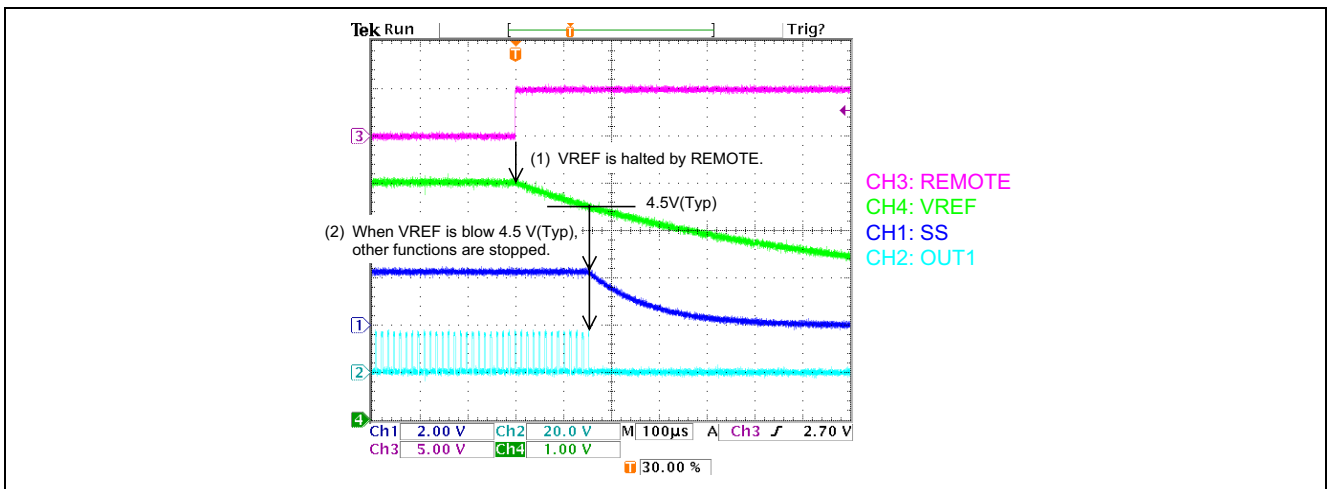

Figure 3 Operation When Remote is Off (Reference Data)

3. Soft Start Circuit

This function gradually increases the pulse width of the OUT pin from 0% duty at start-up to prevent a sudden increase in the pulse width that may cause problems such as transient stress on external parts or overshoot of the secondary-side output voltage.

The soft start time can easily be set with a single external capacitance.

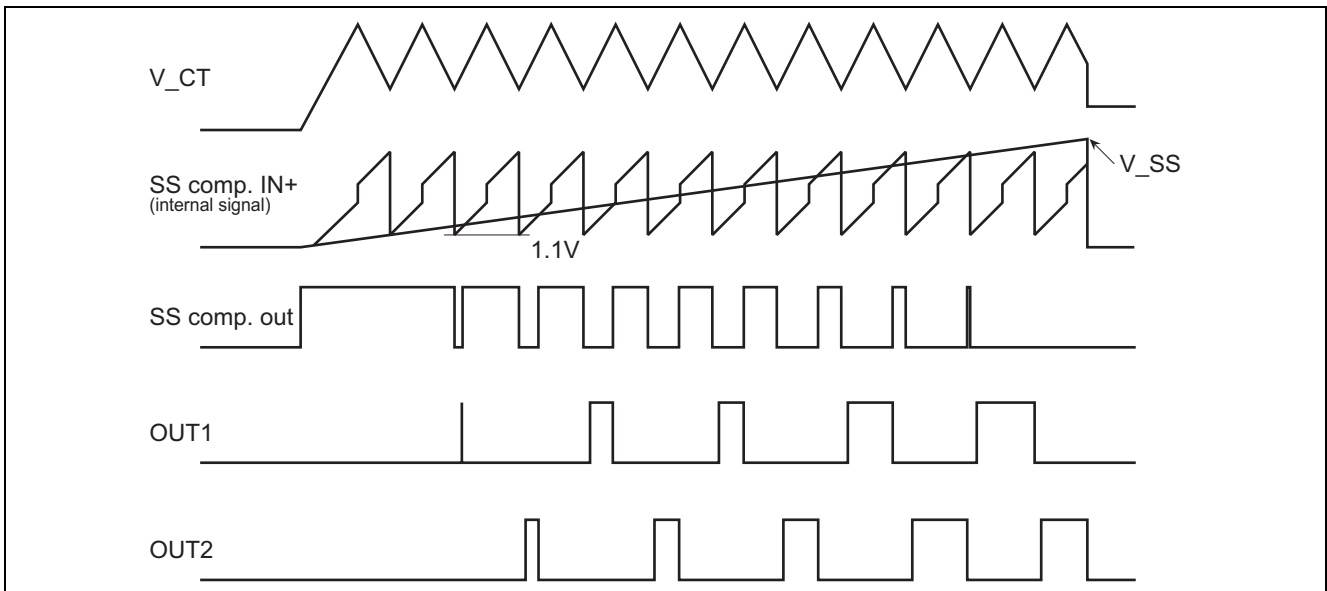

Figure 4

Soft start time t_{ss} is determined by SS pin connection capacitance C_{ss} and an internal constant, and can be estimated using the equation shown below.

Soft start time t_{ss} is the time until the first pulse is output to the driver output OUT pin after VREF starts up following UVLO release.

This is equivalent to the time until the SS pin voltage reaches IC-internal SS comparator reference voltage VTL (1.1 V), and can be calculated using the approximate equation shown below.

Soft start time t_{ss} when C_{ss} is 1000pF is given by the following equation.

$$t_{ss} = \frac{C_{ss} \times V_{TL}}{I_{ss}} = \frac{1000 \text{ [pF]} \times 1.1 \text{ [V]}}{5 \text{ [\mu A]}}$$

$$\approx 220 \text{ [\mu s]}$$

* I_{ss} : SS pin source current, 5 μ A typ.

Note: A soft start circuit operates only once at the start-up of the IC (after the VREF pin voltage is launched and the VrefGOOD circuit is operated). If the SS pin is lowered to 1.1 V or less after the SS pin becomes once high, the pulse of OUT1 and OUT2 is not halt. Each duty cycle of OUT1 and OUT2 is fixed to 25%.

4. Dead Band Generation Circuit

"Dead band" refers to the time when both push-pull dual outputs are off.

By setting the dead band time arbitrarily, it is possible to configure a system in which the dual outputs are never on simultaneously with respect to input and load variations.

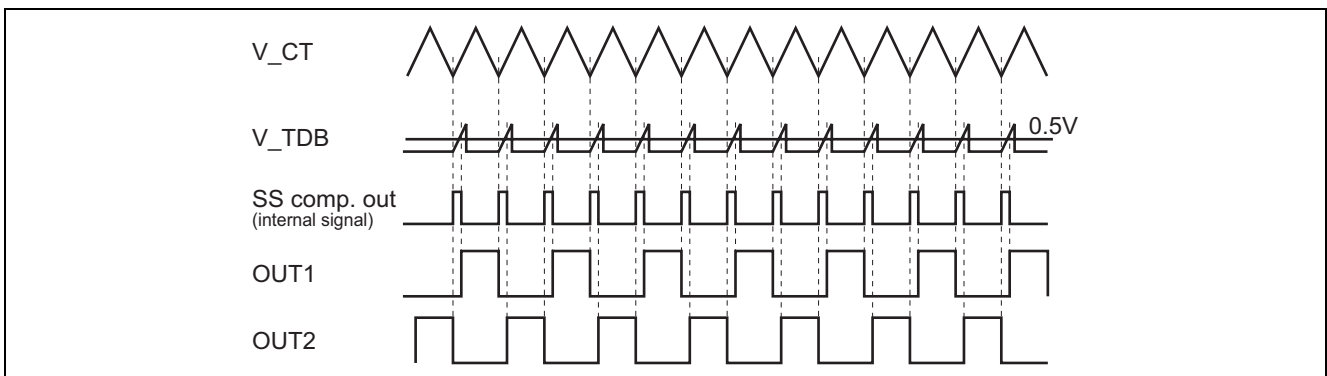

Figure 5

Dead band time t_{db} is determined by TDB pin connection capacitance C_{db} and an internal constant, and can be estimated using the equation shown below.

Even when the TDB pin is open, the dead band time does not become zero due to floating capacitance of the IC package, etc. This dead band time is designated t_{db0} .

Dead band time t_{db} when C_{db} is 47 pF is given by the following equation.

$$t_{db} = t_{db0} + \frac{C_{db} \times V_{th}}{I_{db}} = t_{db0} + \frac{47 \text{ [pF]} \times 0.5 \text{ [V]}}{300 \text{ [\mu A]}}$$

$$= 60 \text{ [ns]} + 78 \text{ [ns]}$$

$$= 138 \text{ [ns]}$$

* I_{db} : TDB pin source current, 300 μ A typ.

* V_{th} : IC-internal TDB comparator reference voltage

5. Operating Frequency

The operating frequency is adjusted by means of CT and RT.

Adjustment examples are shown in the graph below. This graph shows driver output operating frequencies. The reference operating frequency generated at the CT pin is twice the driver output frequency.

The driver output operating frequency can be estimated using the approximate equation shown below.

This is only an approximate equation, and the higher the frequency, the greater will be the degree of error of the approximate equation due to the effects of CT pin voltage overshoot, undershoot and so forth.

When the operating frequency is adjusted, it is essential to confirm operation using the actual system.

$$\begin{aligned}
 f_{osc} &= \frac{8}{3 \times CT \times RT} = \frac{8}{3 \times C6 \times R7} \\
 &= \frac{8}{3 \times 470 \text{ [pF]} \times 27 \text{ [k}\Omega\text{]}} \\
 &= 210 \text{ [kHz]}
 \end{aligned}$$

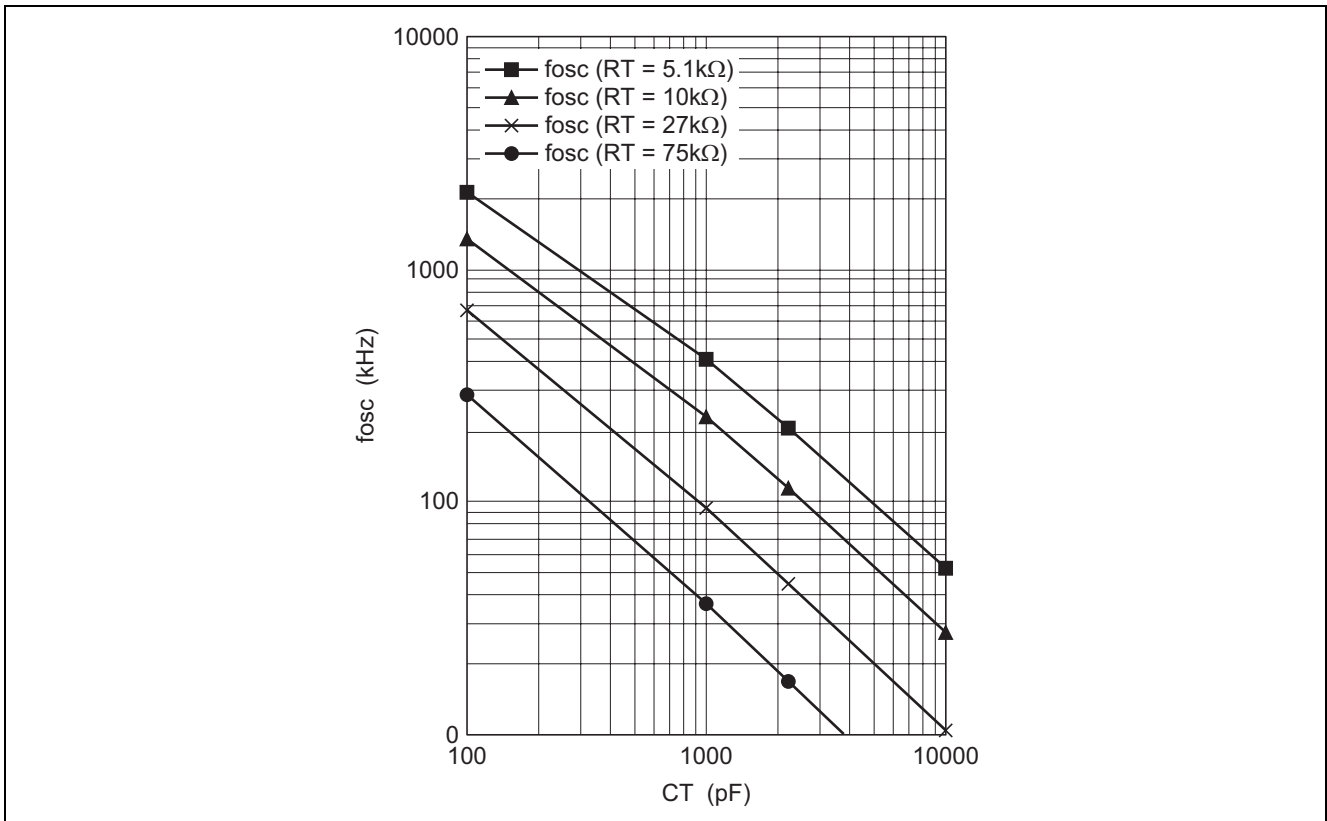

Figure 6

6. Current Limiter Level

The drooping characteristic of the power supply output can be adjusted by adjusting the CSLIM pin voltage.

For example, the drooping characteristic can easily be adjusted, as shown in the figure below, by setting VREF to a divided value with resistances R1 and R2 and connecting adjustment resistance Rx in parallel to R2.

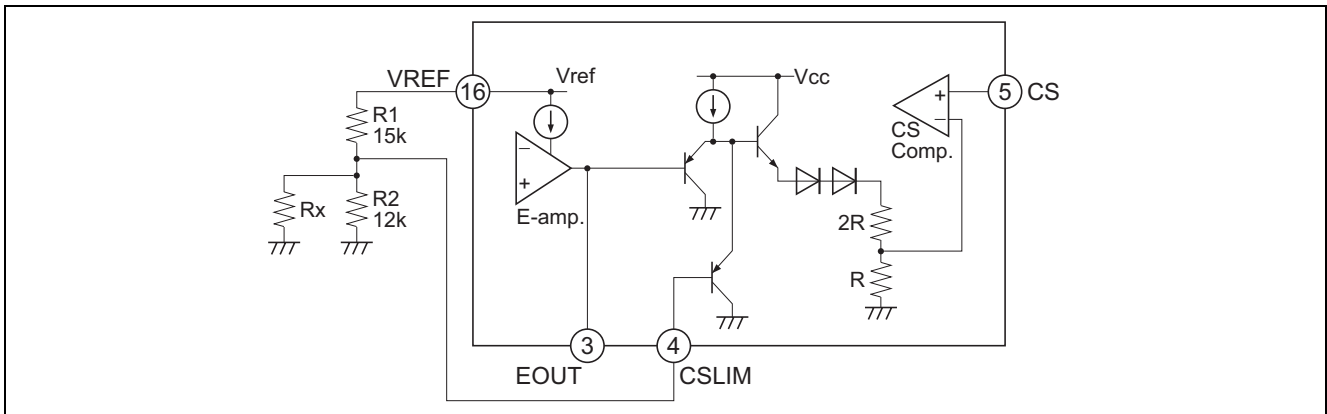

Figure 7 CSLIM Peripheral Circuit

The graph below shows examples of power supply output drooping characteristic adjustment in a push-pull converter.

As shown in this graph, the point at which the power supply output current limit begins to be applied can be adjusted by adjustment of the CSLIM pin voltage.

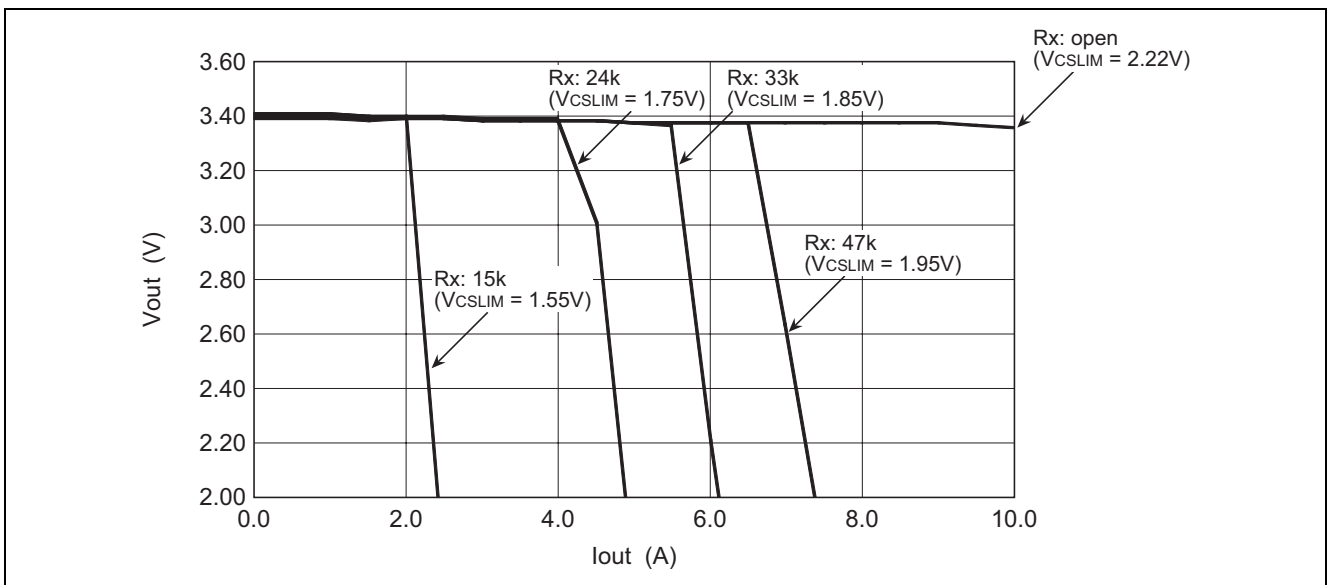

Figure 8 Adjustment of Power Supply Output Drooping Characteristic

7. VREF Circuit

- (1) For the VREF pin, make sure to connect stabilizing capacitance to GND.
- (2) When the value of stabilizing capacitance is small or the load of VREF pin is heavy, either OUT1 or OUT2 may be halted at high level if the IC is stopped by a remote off function. In such a case, increase the capacitance value. The minimum value of capacitance to be connected is approximated by the following equation.

$$C_{ref} > \frac{10\mu\text{s} \times (I_{ref} + 6\text{mA})}{4.95\text{V}}$$

- (3) Depending on the value of capacitance to be connected, overshoot may result at the rising of the VREF pin (see the figure below). Take extra care when the VREF pin voltage is used as the power supply and reference voltage of external circuit.

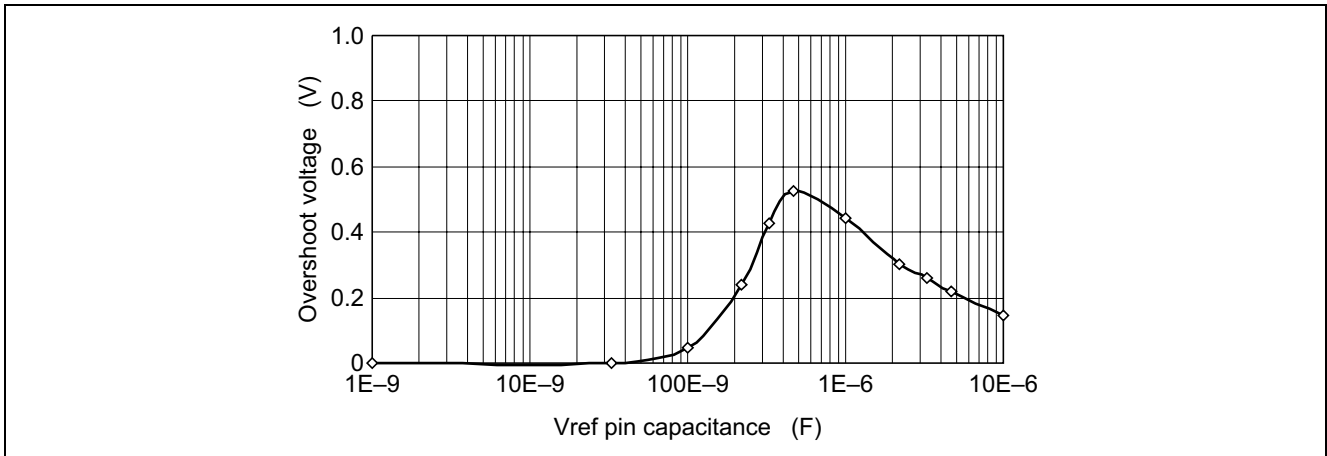

Figure 9 Overshoot Voltage of Vref Pin (Reference Data)

8. CS Pin

RC filter is generally inserted into the CS pin to prevent the pin from malfunction due to noise. The CS pin has an internal circuit to pull out electric charge while both of the OUT1 and OUT2 are at the low level (dead band time). However, please be aware that the electric charge may not be pulled out when the duration of dead band time is short and the filter constant is not appropriate.

9. Usage on Half-bridge Power Supply

The HA16150 is operated in the current mode. However, the half-bridge power supply becomes unstable in principle by using current mode control. The HA16150, therefore, cannot be used basically. In order to use the HA16150 with the half-bridge power supply, add a circuit as shown below and operate the HA16150 in the voltage mode.

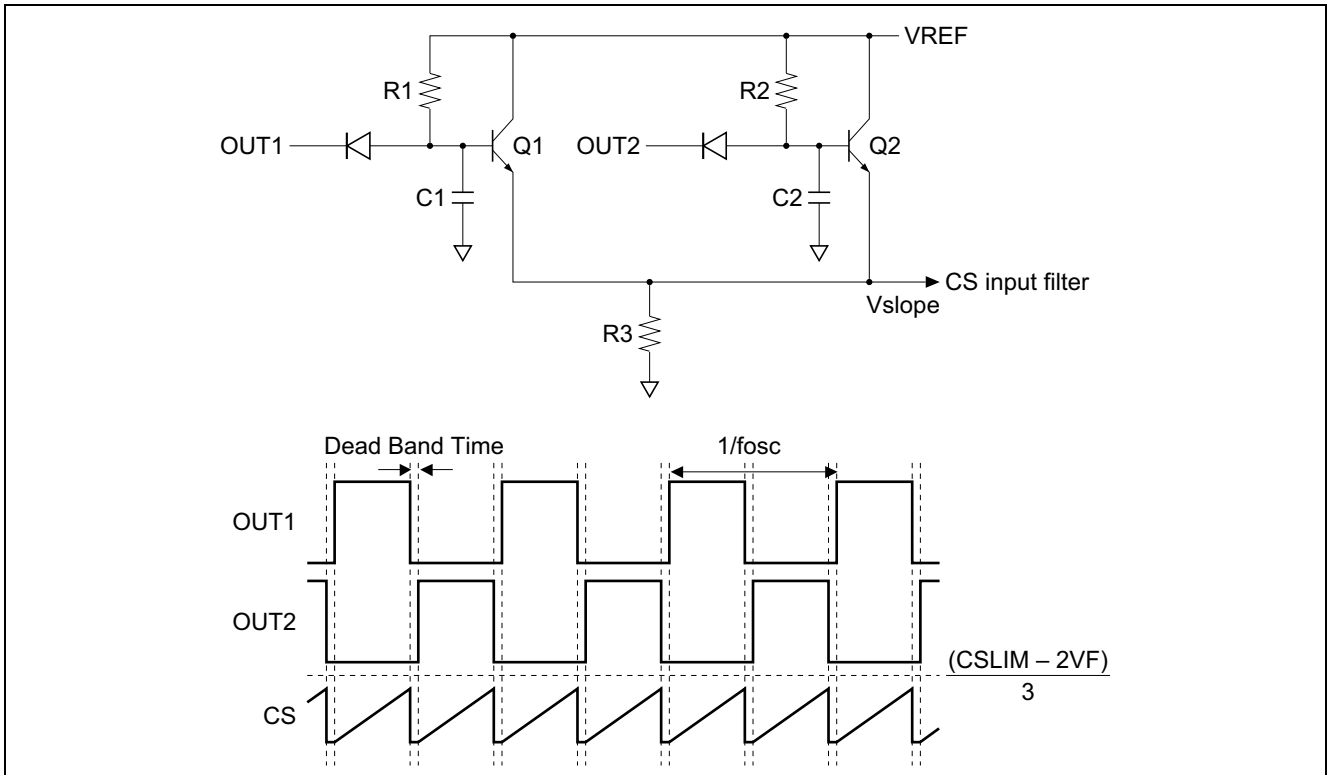
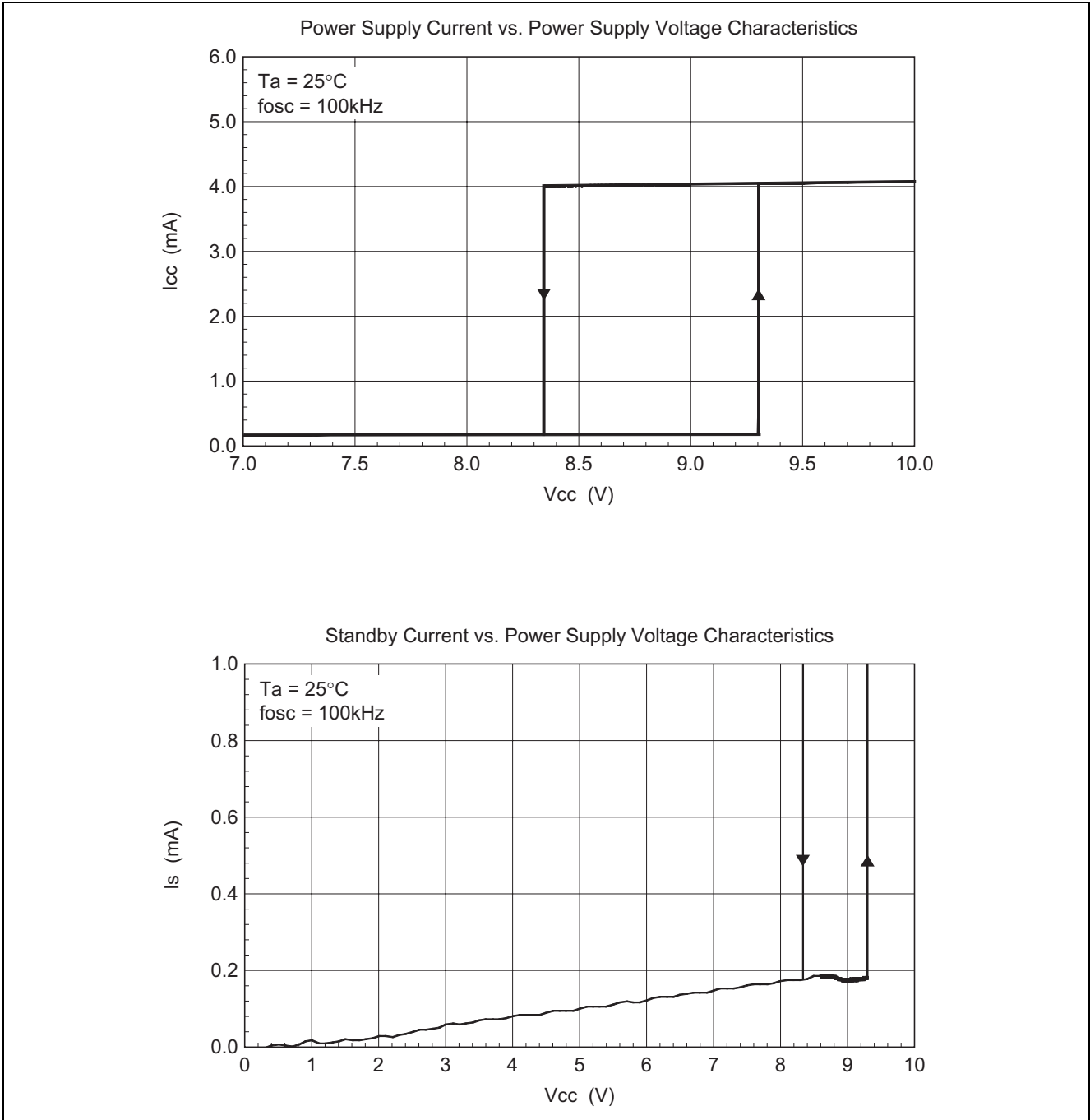

Figure 10 Example of Circuit for Voltage Mode Operation

Design the charging circuits for R1 (R2), C1 (C2), Q1 (Q2) and R3 so that the peak voltage of CS is lower than $(CSLIM - 2VF)/3$ at the maximum ON pulse width of OUT1 and OUT2.

Furthermore, set the input filter values between R3 and CS pin so that the CS voltage is discharged assuredly while both of the OUT1 and OUT2 are at low level.

Characteristic Curves



Power Supply Current vs. Power Supply Voltage (Clamp Zener Voltage) Characteristics

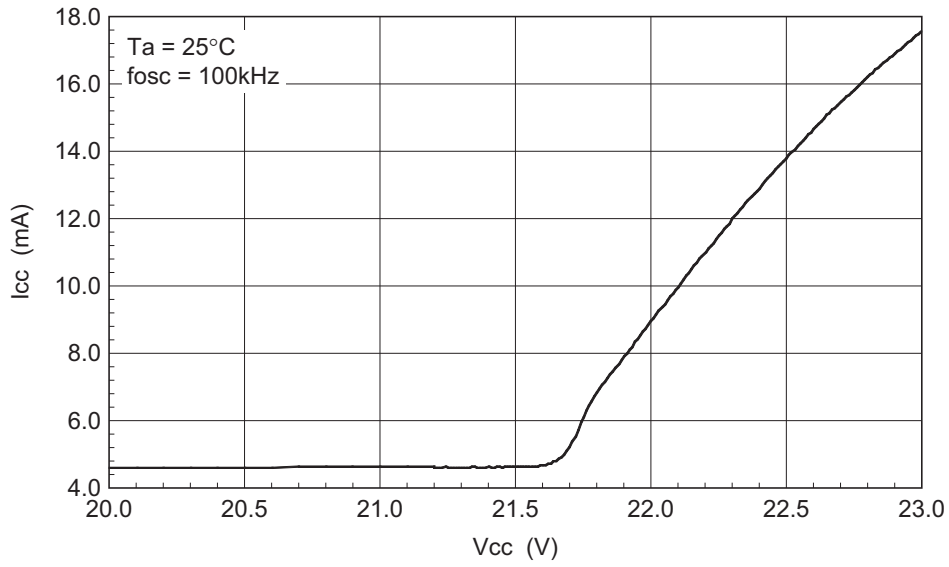

VREF Output Voltage vs. REMOTE Pin Voltage Characteristics

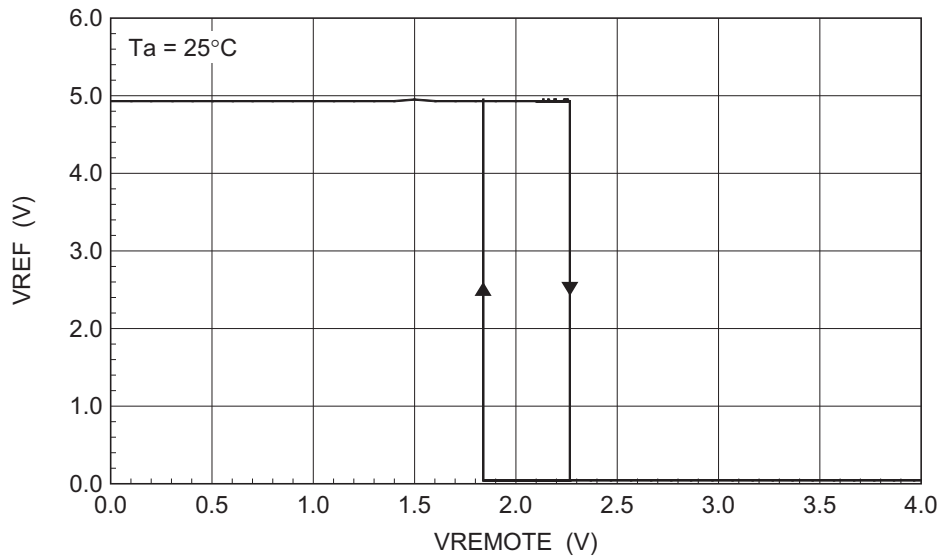

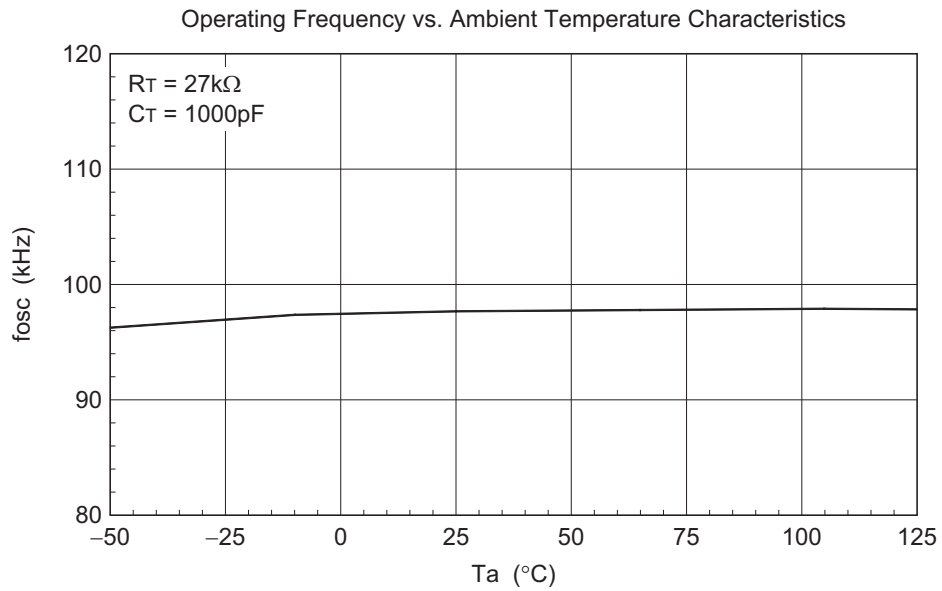
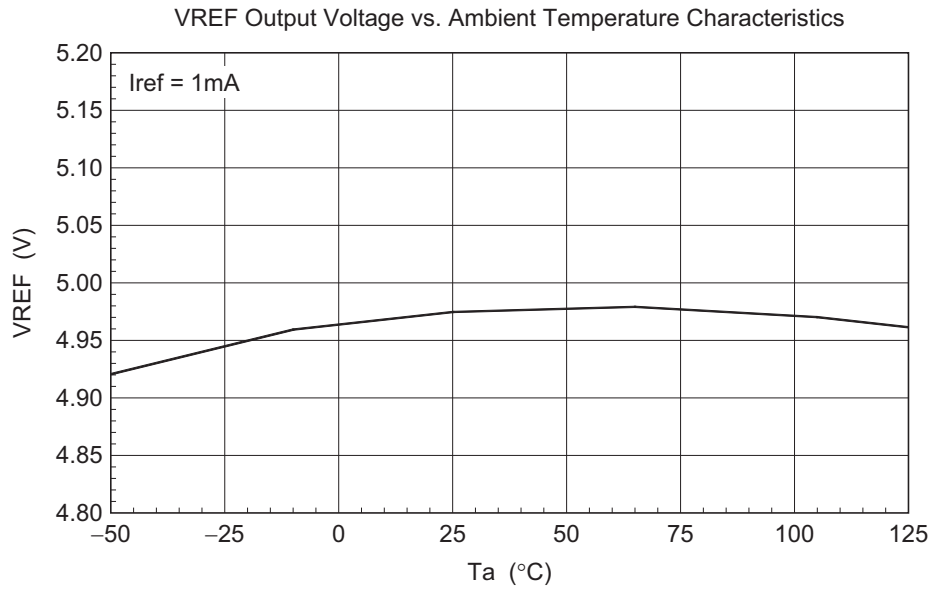

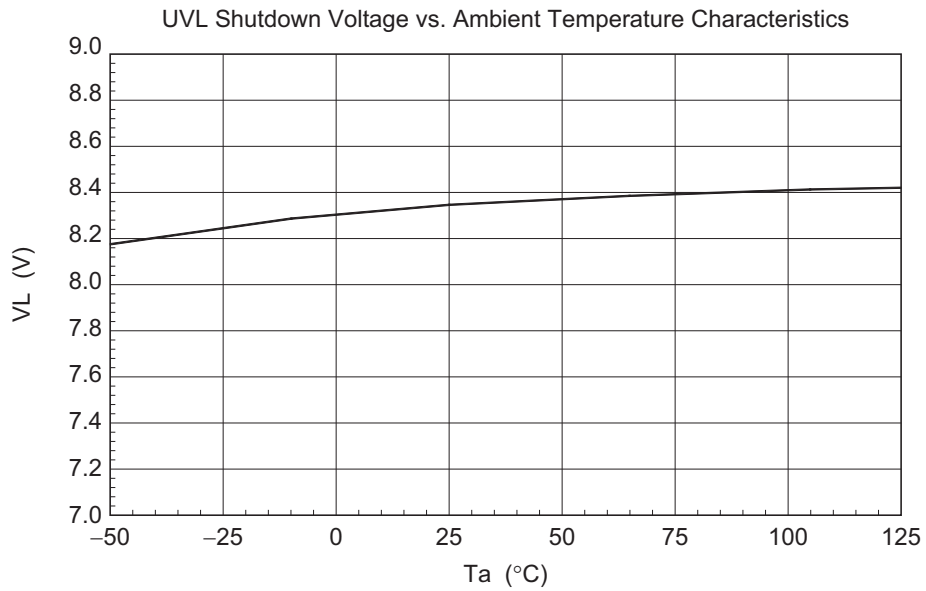
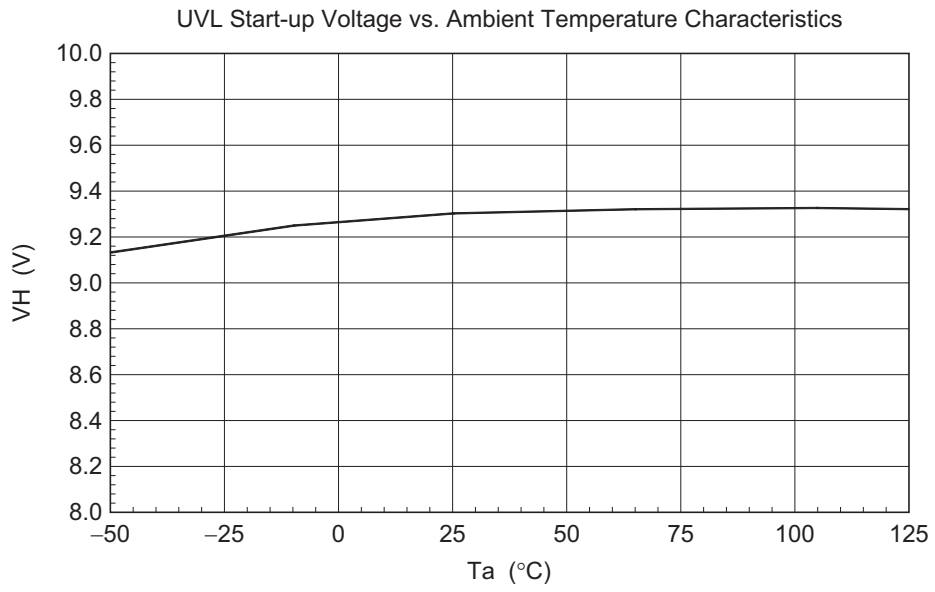

Application Circuit Example

The following diagram shows a sample application circuit for a push-pull converter with a 48 V input voltage, 3.3 V output voltage, and 10 A output current.

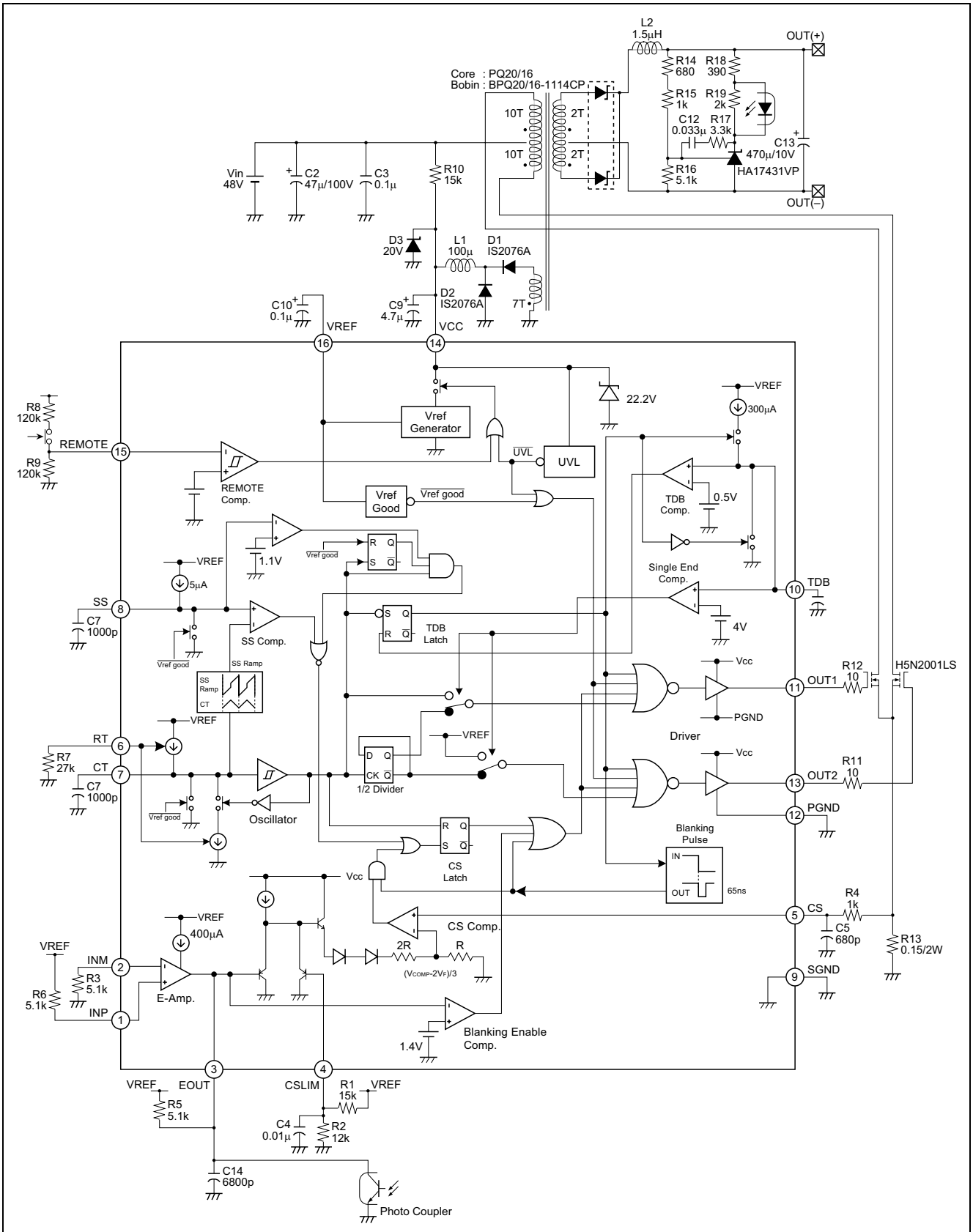

Package Dimensions

As of January, 2003
Unit: mm

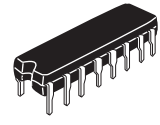
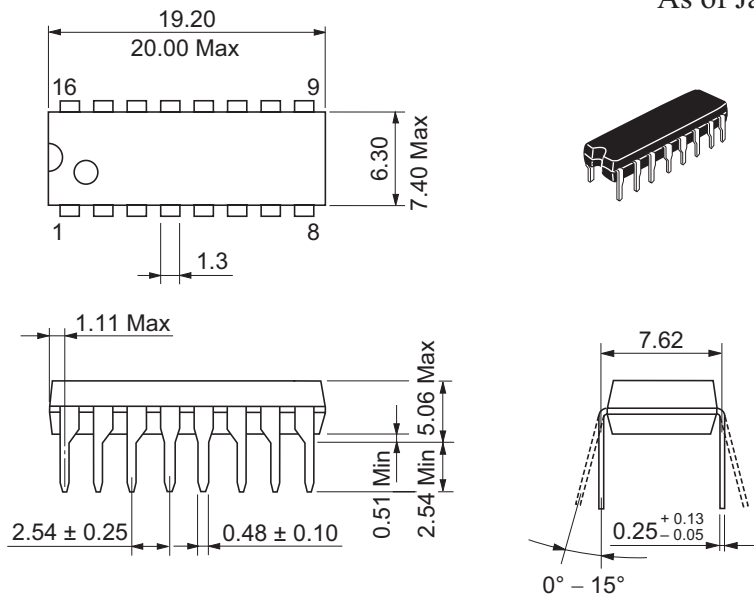

Package Code	DP-16
JEDEC	Conforms
JEITA	Conforms
Mass (reference value)	1.07 g

JEITA Package Code	RENEASAS Code	Previous Code	MASS[Typ.]
P-TSSOP16-4.4x5-0.65	PTSP0016JB-B	TTP-16DA	0.05g

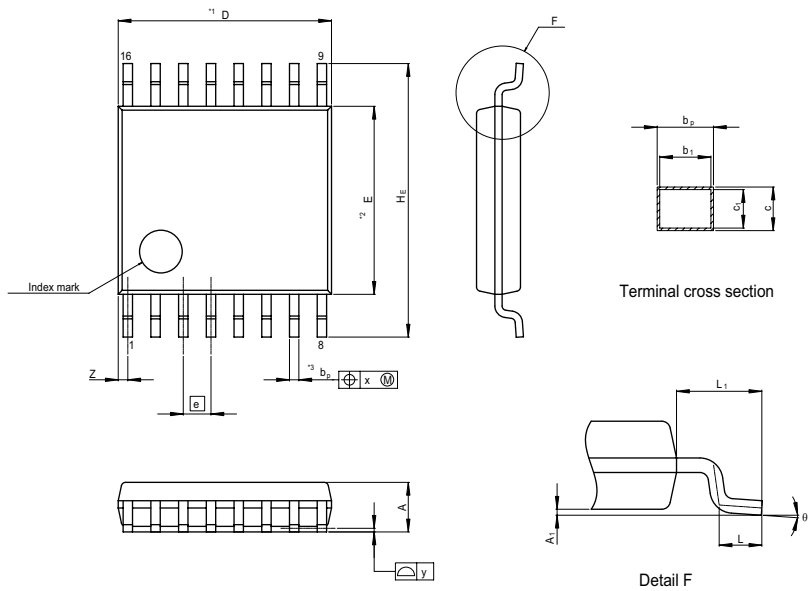

NOTE)
1. DIMENSIONS*1 (Nom)*AND*2* DO NOT INCLUDE MOLD FLASH.
2. DIMENSION*3* DOES NOT INCLUDE TRIM OFFSET.

Reference Symbol	Dimension in Millimeters		
	Min	Nom	Max
D	—	5.00	5.30
E	—	4.40	—
A ₂	—	—	—
A ₁	0.03	0.07	0.10
A	—	—	1.10
b _p	0.15	0.22	0.30
b ₁	—	0.20	—
c	0.12	0.17	0.22
c ₁	—	0.15	—
θ	0°	—	8°
HE	6.20	6.40	6.60
Ⓜ	—	0.65	—
x	—	—	0.13
y	—	—	0.10
Z	—	—	0.65
L	0.40	0.50	0.60
L ₁	—	1.0	—

Notes:

1. This document is provided for reference purposes only so that Renesas customers may select the appropriate Renesas products for their use. Renesas neither makes warranties or representations with respect to the accuracy or completeness of the information contained in this document nor grants any license to any intellectual property rights or any other rights of Renesas or any third party with respect to the information in this document.
2. Renesas shall have no liability for damages or infringement of any intellectual property or other rights arising out of the use of any information in this document, including, but not limited to, product data, diagrams, charts, programs, algorithms, and application circuit examples.
3. You should not use the products or the technology described in this document for the purpose of military applications such as the development of weapons of mass destruction or for the purpose of any other military use. When exporting the products or technology described herein, you should follow the applicable export control laws and regulations, and procedures required by such laws and regulations.
4. All information included in this document such as product data, diagrams, charts, programs, algorithms, and application circuit examples, is current as of the date this document is issued. Such information, however, is subject to change without any prior notice. Before purchasing or using any Renesas products listed in this document, please confirm the latest product information with a Renesas sales office. Also, please pay regular and careful attention to additional and different information to be disclosed by Renesas such as that disclosed through our website. (<http://www.renesas.com>)
5. Renesas has used reasonable care in compiling the information included in this document, but Renesas assumes no liability whatsoever for any damages incurred as a result of errors or omissions in the information included in this document.
6. When using or otherwise relying on the information in this document, you should evaluate the information in light of the total system before deciding about the applicability of such information to the intended application. Renesas makes no representations, warranties or guaranties regarding the suitability of its products for any particular application and specifically disclaims any liability arising out of the application and use of the information in this document or Renesas products.
7. With the exception of products specified by Renesas as suitable for automobile applications, Renesas products are not designed, manufactured or tested for applications or otherwise in systems the failure or malfunction of which may cause a direct threat to human life or create a risk of human injury or which require especially high quality and reliability such as safety systems, or equipment or systems for transportation and traffic, healthcare, combustion control, aerospace and aeronautics, nuclear power, or undersea communication transmission. If you are considering the use of our products for such purposes, please contact a Renesas sales office beforehand. Renesas shall have no liability for damages arising out of the uses set forth above.
8. Notwithstanding the preceding paragraph, you should not use Renesas products for the purposes listed below:
 - (1) artificial life support devices or systems
 - (2) surgical implantations
 - (3) healthcare intervention (e.g., excision, administration of medication, etc.)
 - (4) any other purposes that pose a direct threat to human lifeRenesas shall have no liability for damages arising out of the uses set forth in the above and purchasers who elect to use Renesas products in any of the foregoing applications shall indemnify and hold harmless Renesas Technology Corp., its affiliated companies and their officers, directors, and employees against any and all damages arising out of such applications.
9. You should use the products described herein within the range specified by Renesas, especially with respect to the maximum rating, operating supply voltage range, movement power voltage range, heat radiation characteristics, installation and other product characteristics. Renesas shall have no liability for malfunctions or damages arising out of the use of Renesas products beyond such specified ranges.
10. Although Renesas endeavors to improve the quality and reliability of its products, IC products have specific characteristics such as the occurrence of failure at a certain rate and malfunctions under certain use conditions. Please be sure to implement safety measures to guard against the possibility of physical injury, and injury or damage caused by fire in the event of the failure of a Renesas product, such as safety design for hardware and software including but not limited to redundancy, fire control and malfunction prevention, appropriate treatment for aging degradation or any other applicable measures. Among others, since the evaluation of microcomputer software alone is very difficult, please evaluate the safety of the final products or system manufactured by you.
11. In case Renesas products listed in this document are detached from the products to which the Renesas products are attached or affixed, the risk of accident such as swallowing by infants and small children is very high. You should implement safety measures so that Renesas products may not be easily detached from your products. Renesas shall have no liability for damages arising out of such detachment.
12. This document may not be reproduced or duplicated, in any form, in whole or in part, without prior written approval from Renesas.
13. Please contact a Renesas sales office if you have any questions regarding the information contained in this document, Renesas semiconductor products, or if you have any other inquiries.



RENESAS SALES OFFICES

<http://www.renesas.com>

Refer to "<http://www.renesas.com/en/network>" for the latest and detailed information.

Renesas Technology America, Inc.

450 Holger Way, San Jose, CA 95134-1368, U.S.A
Tel: <1> (408) 382-7500, Fax: <1> (408) 382-7501

Renesas Technology Europe Limited

Dukes Meadow, Millboard Road, Bourne End, Buckinghamshire, SL8 5FH, U.K.
Tel: <44> (1628) 585-100, Fax: <44> (1628) 585-900

Renesas Technology (Shanghai) Co., Ltd.

Unit 204, 205, AZIACenter, No.1233 Lujiazui Ring Rd, Pudong District, Shanghai, China 200120
Tel: <86> (21) 5877-1818, Fax: <86> (21) 6887-7898

Renesas Technology Hong Kong Ltd.

7th Floor, North Tower, World Finance Centre, Harbour City, 1 Canton Road, Tsimshatsui, Kowloon, Hong Kong
Tel: <852> 2265-6688, Fax: <852> 2730-6071

Renesas Technology Taiwan Co., Ltd.

10th Floor, No.99, Fushing North Road, Taipei, Taiwan
Tel: <886> (2) 2715-2888, Fax: <886> (2) 2713-2999

Renesas Technology Singapore Pte. Ltd.

1 Harbour Front Avenue, #06-10, Keppel Bay Tower, Singapore 098632
Tel: <65> 6213-0200, Fax: <65> 6278-8001

Renesas Technology Korea Co., Ltd.

Kukje Center Bldg. 18th Fl., 191, 2-ka, Hangang-ro, Yongsan-ku, Seoul 140-702, Korea
Tel: <82> (2) 796-3115, Fax: <82> (2) 796-2145

Renesas Technology Malaysia Sdn. Bhd

Unit 906, Block B, Menara Amcorp, Amcorp Trade Centre, No.18, Jalan Persiaran Barat, 46050 Petaling Jaya, Selangor Darul Ehsan, Malaysia
Tel: <603> 7955-9390, Fax: <603> 7955-9510