

CVBS Video Filter Amplifier with SmartSleep and Bidirectional Video Support

General Description

The MAX9513 CVBS video filter amplifier with SmartSleep and bidirectional video support is ideal for portable DVD players and portable media players (PMPs). The input can be directly connected to the digital-to-analog converter (DAC) output. The reconstruction filter removes high-frequency signals above 6.75MHz. The amplifiers have 6dB of gain, and the outputs can be DC-coupled to a load of 75Ω, which is equivalent to two video loads, or can be AC-coupled to a load of 150Ω.

The SmartSleep circuitry intelligently reduces power consumption based on the presence of the input signal and the output loads. When the MAX9513 does not detect the presence of sync on the input video signal, the supply current is reduced to less than 7μA. The device only enables a video amplifier when there is an active video input signal and an attached load. The video amplifier remains on while a load is connected. If the load is disconnected, the video amplifier is turned off.

The MAX9513 contains one reconstruction filter, two video amplifiers, and a pulldown switch at one of the two CVBS outputs. The MAX9513 has the ability to control the bidirectional video signals at the CVBS video connections without the need for separate switches or relays. This feature is particularly useful for portable DVD players, which often use the same connector to drive a composite video output and to accept an external video signal to display on the LCD panel.

The MAX9513 operates from a 2.7V to 3.6V single supply and is offered in small 16-pin TQFN (3mm x 3mm) and 16-pin QSOP packages. The device is specified over the -40°C to +125°C automotive temperature range.

Applications

- Portable DVD Players
- Portable Set-Top Boxes
- Personal Video Recorders (PVRs)
- Portable Media Players (PMPs)
- Portable Video

Features

- ◆ SmartSleep Feature Detects Input Signal and Output Load Status to Reduce Power Consumption
- ◆ Standard-Definition Video Reconstruction Filter with 6.75MHz Passband
- ◆ Two Composite Inputs and Outputs
- ◆ Integrated Support for a Bidirectional Composite Video Signal
- ◆ Supports Two Video Loads at Each Output (DC-Coupled)
- ◆ 2.7V to 3.6V Single-Supply Operation

Ordering Information

PART	PIN-PACKAGE	PKG CODE	TOP MARK
MAX9513ATE+	16 TQFN-EP** (3mm x 3mm)	T1633-4	AFC
MAX9513AEE+*	16 QSOP	E16-4	—

Note: All devices are specified over the -40°C to +125°C operating temperature range.

+ Denotes lead-free package.

* Future product—contact factory for availability.

** EP = Exposed pad.

Block Diagrams

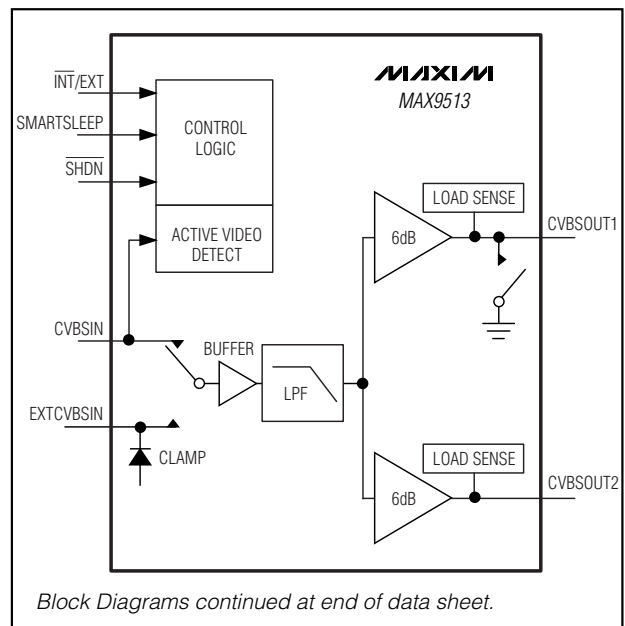

CVBS Video Filter Amplifier with SmartSleep and Bidirectional Video Support

ABSOLUTE MAXIMUM RATINGS

(Voltages with respect to GND.)

VDD	-0.3V to +4V
SMARTSLEEP, SHDN, INT/EXT, CVBSIN, EXTCVBSIN	-0.3V to +4V
Duration of Short Circuit to VDD or GND (CVBSOUT1, CVBSOUT2)	Continuous
Continuous Input Current EXTCVBSIN, CVBSIN, SMARTSLEEP, SHDN, INT/EXT	±20mA

Continuous Power Dissipation ($T_A = +70^\circ\text{C}$)

16-Pin TQFN (derate 15.6mW/°C above +70°C)	1250mW
16-Pin QSOP (derate 8.3mW/°C above +70°C)	667mW
Operating Temperature Range	-40°C to +125°C
Junction Temperature	+150°C
Storage Temperature Range	-65°C to +150°C
Lead Temperature (soldering, 10s)	+300°C

Stresses beyond those listed under "Absolute Maximum Ratings" may cause permanent damage to the device. These are stress ratings only, and functional operation of the device at these or any other conditions beyond those indicated in the operational sections of the specifications is not implied. Exposure to absolute maximum rating conditions for extended periods may affect device reliability.

ELECTRICAL CHARACTERISTICS

($V_{DD} = V_{SHDN} = 3.3\text{V}$, $V_{SMARTSLEEP} = V_{INT/EXT} = \text{GND} = 0\text{V}$, $R_L = \text{no load}$, $T_A = T_{MIN}$ to T_{MAX} , unless otherwise noted. Typical values are at $T_A = +25^\circ\text{C}$.) (Note 1)

PARAMETER	SYMBOL	CONDITIONS	MIN	TYP	MAX	UNITS
Supply Voltage Range	V_{DD}	Guaranteed by PSRR	2.7		3.6	V
Supply Current	I_{DD}	$\overline{\text{INT/EXT}} = \text{GND}$, CVBSIN = 0.3V		13	16	mA
		$\overline{\text{INT/EXT}} = V_{DD}$, EXTCVBSIN is unconnected		4.3	6	
		SMARTSLEEP = V_{DD} , CVBSIN has no active video signal		7	14	μA
		SMARTSLEEP = V_{DD} , CVBSIN has a black-burst video signal with sync tip at GND (Note 2)		17		
Shutdown Supply Current	I_{SHDN}	$\overline{V_{SHDN}} = \text{GND}$		0.01	10	μA
SMARTSLEEP CHARACTERISTICS						
Minimum Line Frequency		CVBSIN	14.3			kHz
Sync Slice Level		CVBSIN	4.1		5.2	% V_{DD}
Output Load Detect Threshold		Sync pulse present, R_L to GND			200	Ω
DC CHARACTERISTICS						
Input Voltage Range	V_{IN}	CVBSIN, guaranteed by output voltage swing	$2.7\text{V} < V_{DD} < 3.6\text{V}$	0	1.05	V
			$3.0\text{V} < V_{DD} < 3.6\text{V}$	0	1.2	
Input Current	I_{IN}	CVBSIN = 0V		2	5	μA
Input Resistance	R_{IN}	CVBSIN		20		M Ω

CVBS Video Filter Amplifier with SmartSleep and Bidirectional Video Support

MAX9513

ELECTRICAL CHARACTERISTICS (continued)

($V_{DD} = V_{SHDN} = 3.3V$, $V_{SMARTSLEEP} = V_{INT/EXT} = GND = 0V$, $R_L = \text{no load}$. $T_A = T_{MIN}$ to T_{MAX} , unless otherwise noted. Typical values are at $T_A = +25^\circ\text{C}$.) (Note 1)

PARAMETER	SYMBOL	CONDITIONS		MIN	TYP	MAX	UNITS
Sync-Tip Clamp Level	V_{CLP}	EXTCVBSIN		0.25		0.37	V
Input Clamping Current		EXTCVBSIN = 500mV + V_{CLP}		0.5	1	1.5	μA
EXTCVBSIN Input Voltage Range		Guaranteed by output voltage swing	$2.7V < V_{DD} < 3.6V$			1.05	V_{P-P}
			$3.0V < V_{DD} < 3.6V$			1.2	
Sync Crush		EXTCVBSIN, percentage reduction in sync pulse (0.3V _{P-P}), guaranteed by input clamping current measurement, measured at input				2	%
Maximum Input Source Resistance		EXTCVBSIN			300		Ω
DC Voltage Gain	A_V	$R_L = 150\Omega$ to $V_{DD} / 2$, $0V \leq V_{IN} \leq 1.05V$, $V_{DD} = 2.7V$		5.7	6	6.3	dB
DC Gain Matching		$R_L = 150\Omega$ to $V_{DD} / 2$, $0V \leq V_{IN} \leq 1.05V$, $V_{DD} = 2.7V$		-0.2	0	+0.2	dB
Output Level		CVBSIN = 0V, INT/EXT = GND, $R_L = 150\Omega$ to GND		0.21	0.3	0.38	V
		CEXTCVBSIN = 0.1 μF to GND, INT/EXT = V_{DD} , $R_L = 150\Omega$ to GND		0.21	0.27	0.38	
Output Voltage Swing		Measured at output, $V_{DD} = 2.7V$, $0V \leq V_{IN} \leq 1.05V$, $R_L = 150\Omega$ to -0.2V	$T_A = -40^\circ\text{C}$ to $+85^\circ\text{C}$	2.027	2.1	2.163	V_{P-P}
			$T_A = -40^\circ\text{C}$ to $+125^\circ\text{C}$	2.006		2.163	
		Measured at output, $V_{DD} = 2.7V$, $0V \leq V_{IN} \leq 1.05V$, $R_L = 150\Omega$ to $V_{DD} / 2$		2.027	2.1	2.163	
		Measured at output, $V_{DD} = 3V$, $0V \leq V_{IN} \leq 1.2V$, $R_L = 150\Omega$ to -0.2V	$T_A = -40^\circ\text{C}$ to $+85^\circ\text{C}$	2.316	2.4	2.472	
			$T_A = -40^\circ\text{C}$ to $+125^\circ\text{C}$	2.292		2.472	
		Measured at output, $V_{DD} = 3V$, $0V \leq V_{IN} \leq 1.2V$, $R_L = 150\Omega$ to $V_{DD} / 2$		2.316	2.4	2.472	
		Measured at output, $V_{DD} = 3.135V$, $0V \leq V_{IN} \leq 1.05V$, $R_L = 75\Omega$ to -0.2V		2.027	2.1	2.163	
Output Resistance	R_{OUT}	$V_{OUT} = 1.3V$, $-5\text{mA} \leq I_{LOAD} \leq +5\text{mA}$			0.47		Ω

CVBS Video Filter Amplifier with SmartSleep and Bidirectional Video Support

ELECTRICAL CHARACTERISTICS (continued)

($V_{DD} = V_{SHDN} = 3.3V$, $V_{SMARTSLEEP} = V_{INT/EXT} = GND = 0V$, $R_L = \text{no load}$, $T_A = T_{MIN}$ to T_{MAX} , unless otherwise noted. Typical values are at $T_A = +25^\circ\text{C}$.) (Note 1)

PARAMETER	SYMBOL	CONDITIONS	MIN	TYP	MAX	UNITS
Power-Supply Rejection Ratio	PSRR	$2.7V \leq V_{DD} \leq 3.6V$, input referred, $R_L = 150\Omega$ to GND	48			dB
Output Pulldown Resistance	R_{PD}	$\overline{INT/EXT} = V_{DD}$, CVBSOUT1		3.7		Ω
Output Shutdown Impedance				28		$k\Omega$
LOGIC INPUTS (SMARTSLEEP, SHDN, INT/EXT)						
Logic-Low Threshold	V_{IL}				$0.3 \times V_{DD}$	V
Logic-High Threshold	V_{IH}		$0.7 \times V_{DD}$			V
Logic Input Current	I_{IL} / I_{IH}	$V_I = 0V$ or V_{DD}		0.01	10	μA

AC ELECTRICAL CHARACTERISTICS

($V_{DD} = V_{SHDN} = 3.3V$, $V_{SMARTSLEEP} = V_{INT/EXT} = GND = 0V$, $R_L = 150\Omega$ to GND, $T_A = T_{MIN}$ to T_{MAX} , unless otherwise noted. Typical values are at $T_A = +25^\circ\text{C}$.) (Note 1)

PARAMETER	SYMBOL	CONDITIONS	MIN	TYP	MAX	UNITS	
Standard-Definition Reconstruction Filter		Inputs are 1V _{p-p} , reference frequency is 1MHz	$f = 5.5\text{MHz}$	-0.1		dB	
			$f = 6.75\text{MHz}$	-1	-0.3		+1
			$f = 11\text{MHz}$		-3		
			$f = 27\text{MHz}$	-33	-41		
Differential Gain	DG	DC-coupled output, 5-step modulated staircase	$f = 3.58\text{MHz}$ or 4.43MHz	0.2		%	
		AC-coupled output, 5-step modulated staircase	$f = 3.58\text{MHz}$ or 4.43MHz	0.4			
Differential Phase	DP	DC-coupled output, 5-step modulated staircase	$f = 3.58\text{MHz}$	0.62		Degrees	
			$f = 4.43\text{MHz}$	0.75			
		AC-coupled output, 5-step modulated staircase	$f = 3.58\text{MHz}$	0.78			
			$f = 4.43\text{MHz}$	1.01			
2T Pulse Response		$2T = 200\text{ns}$ or 250ns		0.2		K%	
2T Bar Response		Bar time is 18 μs , the beginning 2.5% and the ending 2.5% of the bar time are ignored, $2T = 200\text{ns}$ or 250ns		0.2		K%	
2T Pulse-to-Bar K Rating		Bar time is 18 μs , the beginning 2.5% and the ending 2.5% of the bar time are ignored, $2T = 200\text{ns}$ or 250ns		0.3		K%	

CVBS Video Filter Amplifier with SmartSleep and Bidirectional Video Support

MAX9513

AC ELECTRICAL CHARACTERISTICS (continued)

($V_{DD} = V_{SHDN} = 3.3V$, $V_{SMARTSLEEP} = V_{INT/EXT} = GND = 0V$, $R_L = 150\Omega$ to GND. $T_A = T_{MIN}$ to T_{MAX} , unless otherwise noted. Typical values are at $T_A = +25^\circ C$.) (Note 1)

PARAMETER	SYMBOL	CONDITIONS	MIN	TYP	MAX	UNITS
Nonlinearity		5-step staircase		0.1		%
Group Delay Distortion		$100kHz \leq f \leq 5MHz$, inputs are $1V_{P-P}$		10		ns
Peak Signal to RMS Noise		$100kHz \leq f \leq 5MHz$, inputs are $1V_{P-P}$		67		dB
Power-Supply Rejection Ratio		$f = 100kHz$, $200mV_{P-P}$, input referred		43		dB
Output Impedance		$f = 5MHz$		6		Ω
Enable Time		CVBSIN = 1V, output settled to within 1% of the final voltage, $R_L = 150\Omega$ to GND		13		μs
Disable Time		CVBSIN = 1V, output settled to within 1% of the final voltage, $R_L = 150\Omega$ to GND		1.1		μs
CROSSTALK						
All Hostile Output Crosstalk		$f = 4.43MHz$		-70		dB
All Hostile Input Crosstalk		$f = 4.43MHz$, $\overline{SHDN} = GND$, input termination resistors are 75Ω		-69		dB

Note 1: All devices are 100% production tested at $T_A = +25^\circ C$. Specifications over temperature limits are guaranteed by design.

Note 2: Specified current is an average over time.

CVBS Video Filter Amplifier with SmartSleep and Bidirectional Video Support

Typical Operating Characteristics

($V_{DD} = V_{SHDN} = +3.3V$, $V_{SMARTSLEEP} = V_{INT}/EXT = GND = 0V$, $R_L = 150\Omega$ to GND. $T_A = +25^\circ C$, unless otherwise noted.)

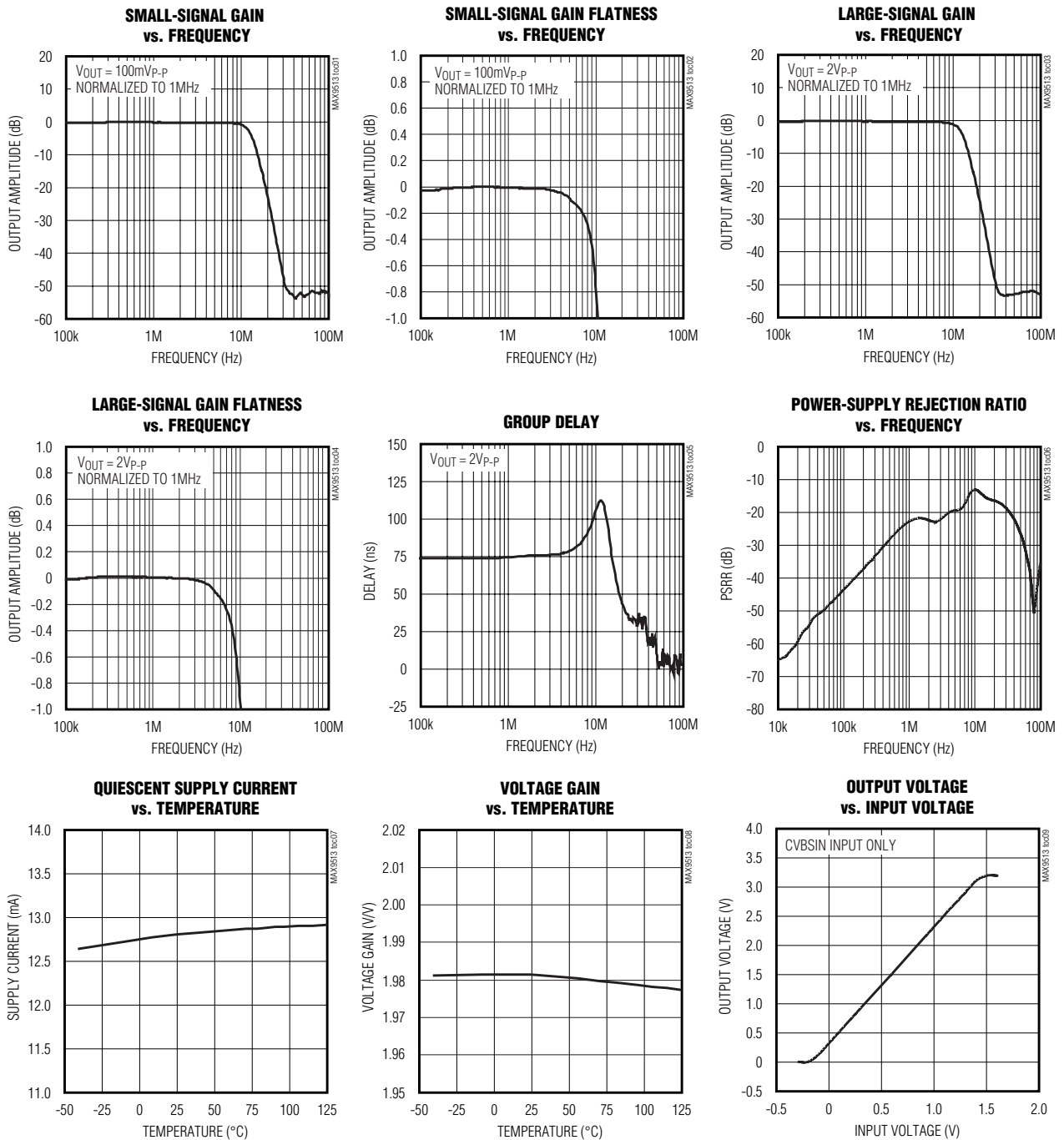

CVBS Video Filter Amplifier with SmartSleep and Bidirectional Video Support

Typical Operating Characteristics (continued)

($V_{DD} = V_{SHDN} = +3.3V$, $V_{SMARTSLEEP} = V_{INT/EXT} = GND = 0V$, $R_L = 150\Omega$ to GND, $T_A = +25^\circ C$, unless otherwise noted.)

MAX9513

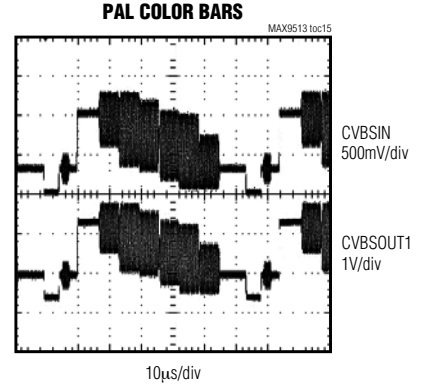
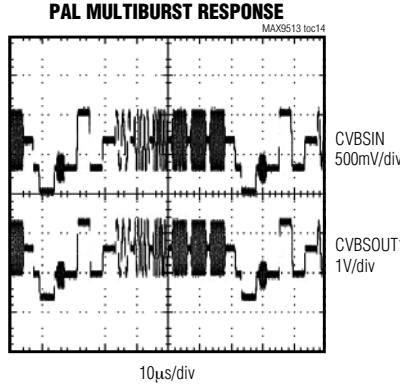
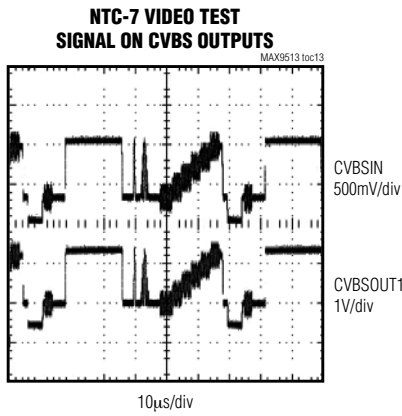
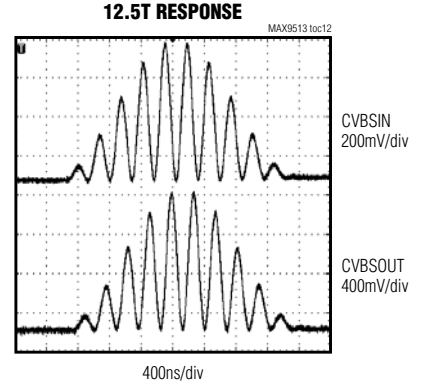
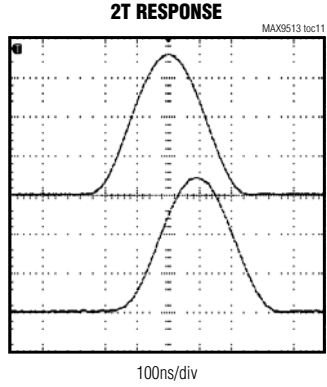
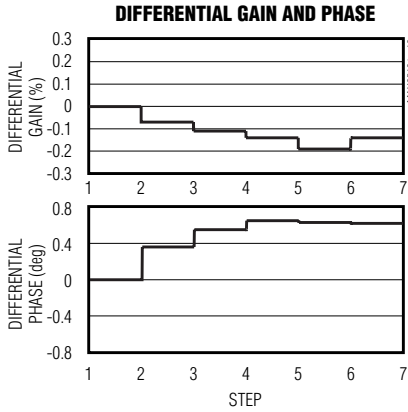

CVBS Video Filter Amplifier with SmartSleep and Bidirectional Video Support

Typical Operating Characteristics (continued)

($V_{DD} = V_{SHDN} = +3.3V$, $V_{SMARTSLEEP} = V_{INT}/EXT = GND = 0V$. $R_L = 150\Omega$ to GND. $T_A = +25^\circ C$, unless otherwise noted.)

FIELD SQUARE-WAVE RESPONSE

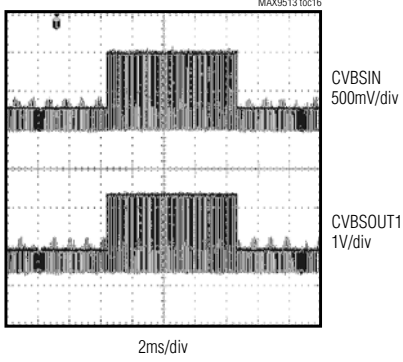

ENABLE TIME

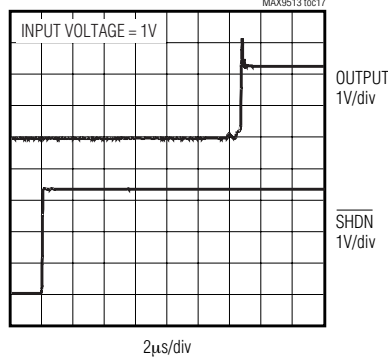

DISABLE TIME

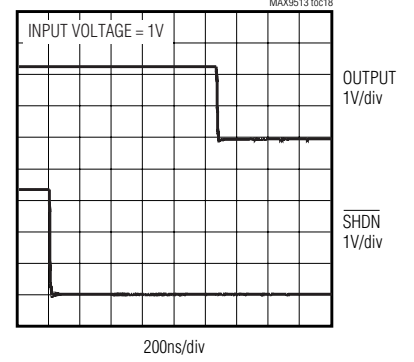

PULLDOWN RESISTANCE DISTRIBUTION

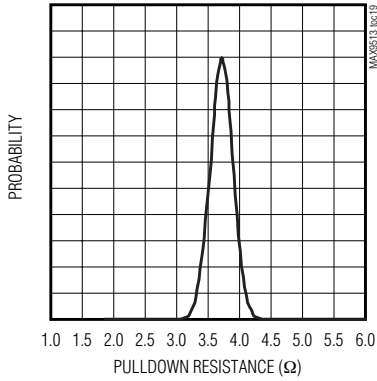

PULLDOWN RESISTANCE vs. TEMPERATURE

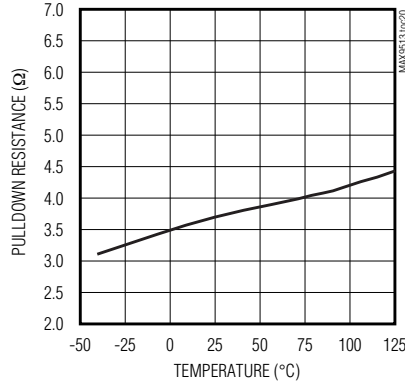

FREQUENCY RESPONSE AT 6.75MHz DISTRIBUTION

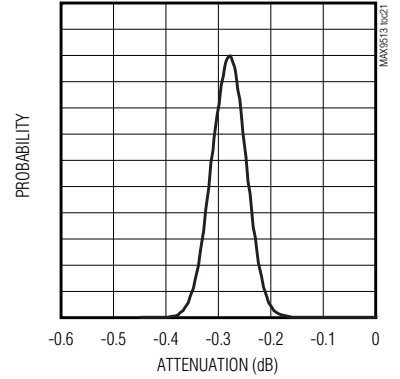

CVBS Video Filter Amplifier with SmartSleep and Bidirectional Video Support

MAX9513

Typical Operating Characteristics (continued)

($V_{DD} = V_{SHDN} = +3.3V$, $V_{SMARTSLEEP} = \overline{INT}/EXT = GND = 0V$, $R_L = 150\Omega$ to GND. $T_A = +25^\circ C$, unless otherwise noted.)

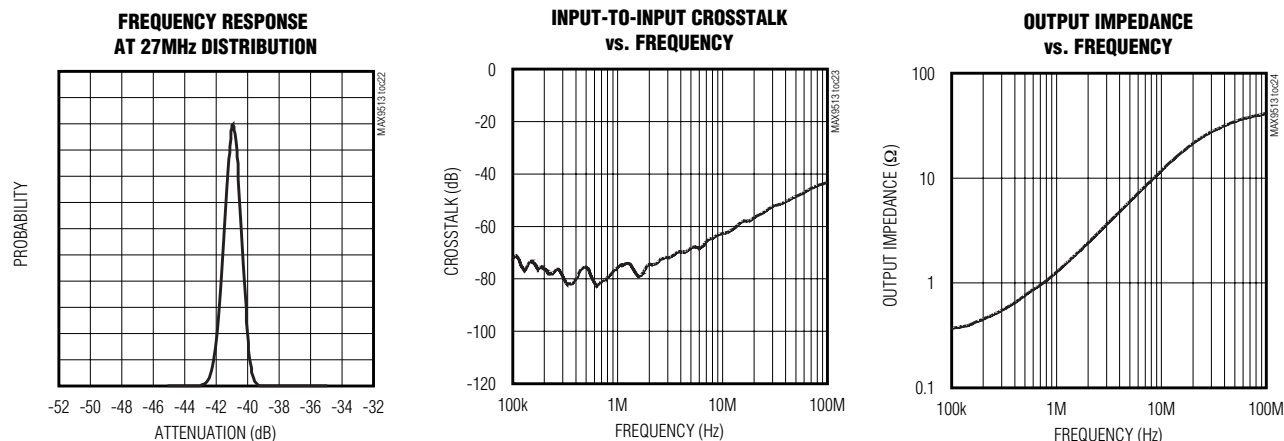

Pin Description

PIN		NAME	FUNCTION
TQFN	QSOP		
1, 13	3, 15	V_{DD}	Power Supply. Bypass V_{DD} with a 0.1 μ F capacitor to ground.
2, 3, 8, 16	2, 4, 5, 10	GND	Ground
4	6	CVBSIN	Internal CVBS Signal Input. Directly connect this input to the video DAC output.
5	7	EXTCVBSIN	External CVBS Signal Input. AC-couple the signal through a 0.1 μ F capacitor to this input.
6	8	\overline{SHDN}	Active-Low Shutdown Logic Input. Connect to logic-low to place device in shutdown. Connect to logic-high for normal operation.
7, 11, 12	9, 13, 14	N.C.	No Connection. Connect to GND.
9	11	CVBSOUT2	CVBS Output 2
10	12	CVBSOUT1	CVBS Output 1. CVBSOUT1 is actively pulled to GND when \overline{INT}/EXT is logic-high.
14	16	\overline{INT}/EXT	Internal/External CVBS Logic Input. Connect \overline{INT}/EXT low to process CVBS video signals from CVBSIN input. Connect \overline{INT}/EXT high to process CVBS video signals from EXTCVBSIN input.
15	1	SMARTSLEEP	SmartSleep Logic Input. Connect to logic-high to activate SmartSleep operation.
EP	—	EP	Exposed Pad. Connect EP to GND. EP is also internally connected to GND.

CVBS Video Filter Amplifier with SmartSleep and Bidirectional Video Support

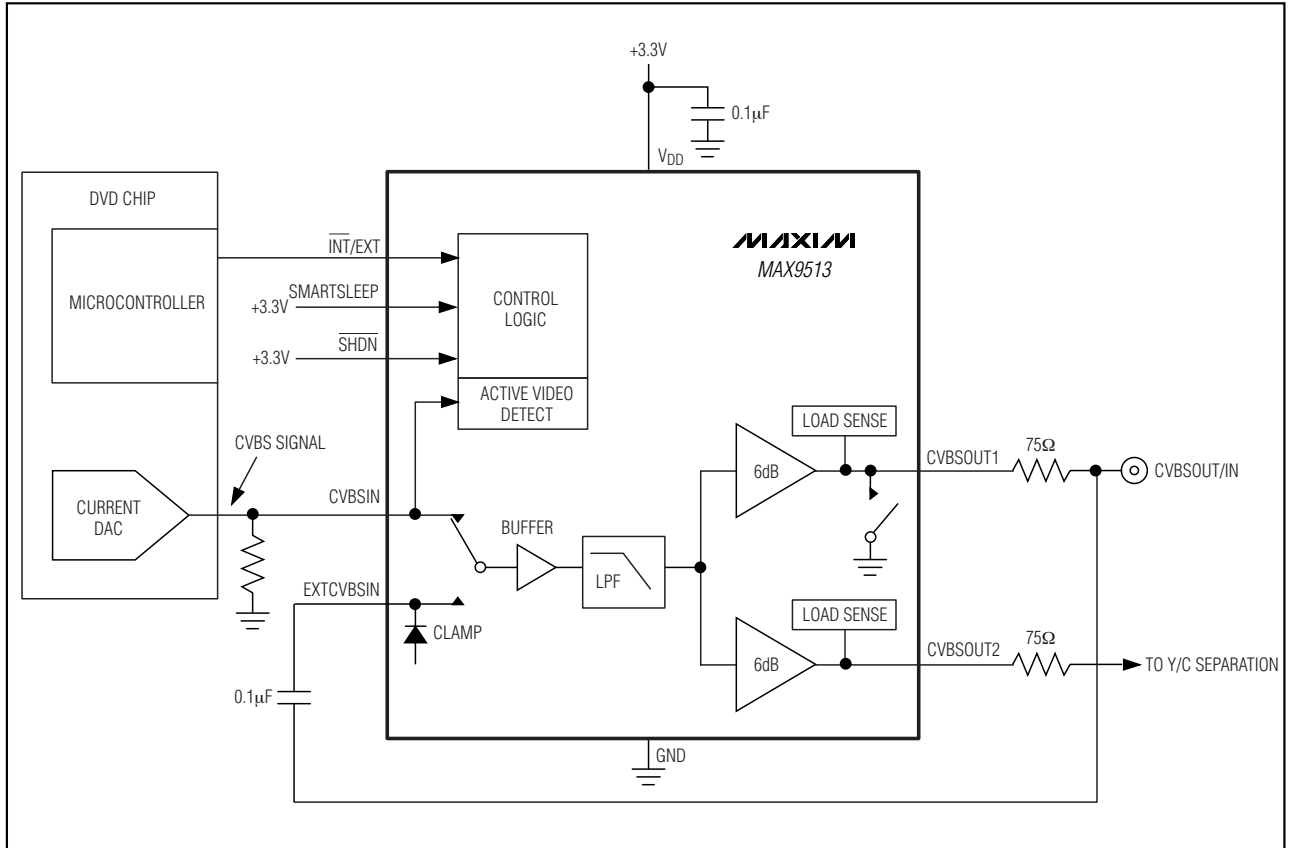

Figure 1. Typical Application Circuit for Portable DVD Player

Detailed Description

In the typical application circuit shown in Figure 1, the current DAC generates an internal video signal. When the internal signal source is selected, the MAX9513 filters the signal and then drives the video connectors through a 75Ω back termination resistor. When the external video source is selected, the MAX9513 selects the external video signal (EXTVCBSIN), then clamps, filters, and amplifies it. The output stage of the amplifier connected to CVBSOUT1 becomes high impedance. The n-channel switch at CVBSOUT1 turns on, thereby converting the back termination resistor into an input termination resistor.

SmartSleep Feature

The SmartSleep feature is activated when the SMARTSLEEP input is connected to logic-high. The SmartSleep feature provides intelligent power management by selectively disabling the filters and output amplifiers based on the presence of video signals or loads attached to the outputs. If the SmartSleep feature is not activated and the part is not in shutdown, the filters and output amplifiers completely turn on, regardless of whether there is a video signal at the CVBSIN input and whether there are loads connected at the outputs. SmartSleep only works with DC-coupled loads.

CVBS Video Filter Amplifier with SmartSleep and Bidirectional Video Support

Standby Mode

In standby mode, the filter and output amplifiers are off, and only the active video detect circuit is operational. Quiescent current consumption is approximately 7 μ A (Figure 2). The active video detect circuit checks whether sync is present on the CVBSIN signal. If no sync is detected, the device remains in standby mode.

Active-Detect Mode

The active video detect circuit slices the CVBSIN signal at 4.7% of the power supply (155mV for a 3.3V supply). If the transitions occur at a rate of 14.3kHz or higher, a

video signal is present. When the MAX9513 detects a video signal with sync at the CVBSIN input, the control logic enters the active-detect mode and enables the load-sense circuitry (Figure 3). The supply current is typically 17 μ A.

If an output load is not connected to any amplifier, the MAX9513 remains in active-detect mode. Eight times per second, each load-sense circuit checks for a load by connecting an internal 15k Ω pullup resistor to the output for 1ms. If the output is pulled up, no load is present. If the output stays low, a load is connected.

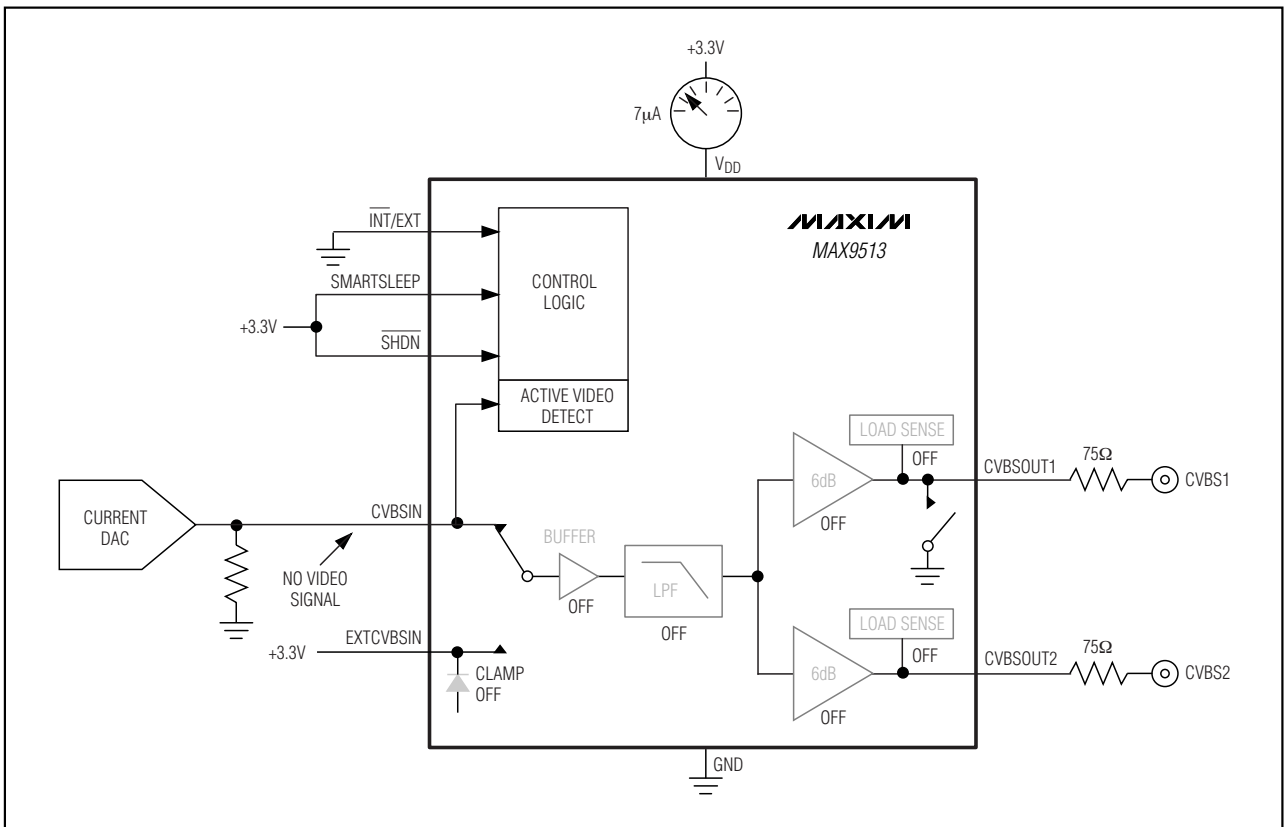

Figure 2. Standby Mode

CVBS Video Filter Amplifier with SmartSleep and Bidirectional Video Support

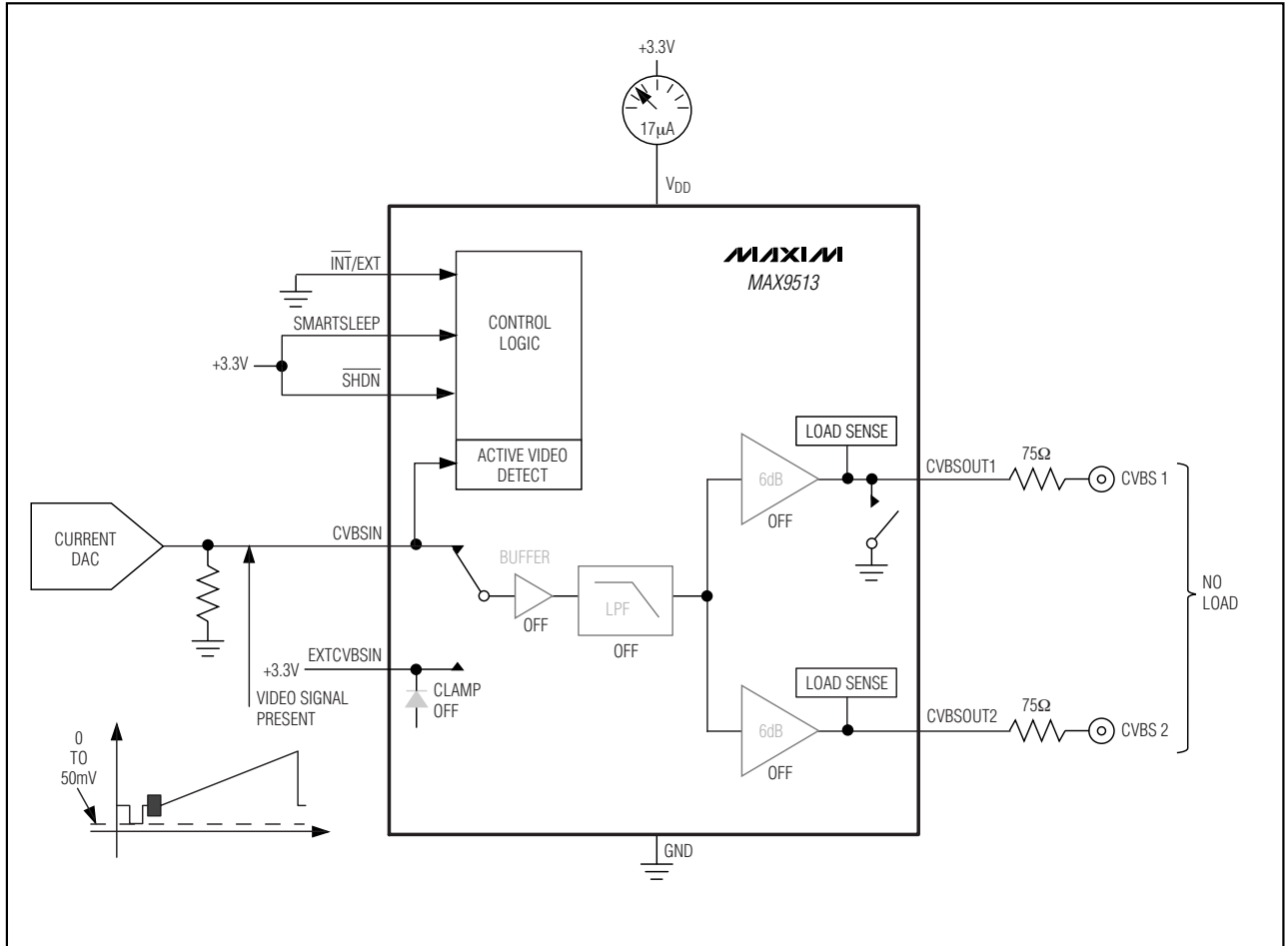

Figure 3. Active-Detect Mode with No Output Loads

CVBS Video Filter Amplifier with SmartSleep and Bidirectional Video Support

Full-Operation Mode

If a load is connected to an output, the corresponding filter and amplifier turn on and remain on until the output load is disconnected. In full-operation mode, SmartSleep intelligently reduces the supply current based on the input signal presence and output loading. Figures 4, 5, and 6 show which portions of the MAX9513 turn on and which remain off with different load configurations.

When an amplifier is on, it continually checks if the load has been disconnected by detecting if the amplifier

output is sourcing current during a horizontal line time. If no sourcing current is detected within one horizontal line time (approximately 64 μ s), the load has been disconnected and the amplifier returns to active-detect mode. If, at any time, the input video signal is removed, the MAX9513 returns to standby mode.

If the SmartSleep feature is not activated and the part is not in shutdown, the filters and amplifiers completely turn on, regardless of whether there is a video signal at the CVBSIN input and whether there are loads connected at the outputs.

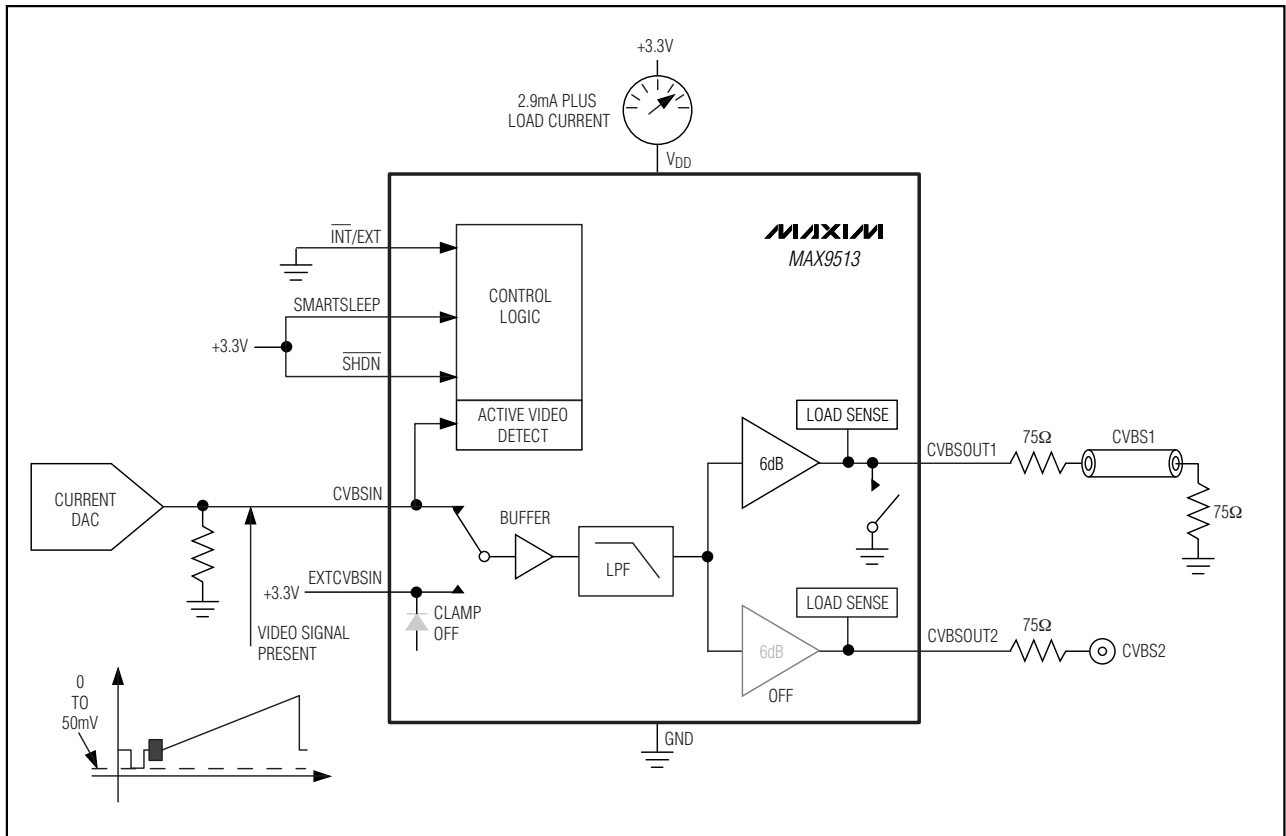

Figure 4. Full-Operation Mode with CVBSOUT1 Loaded

CVBS Video Filter Amplifier with SmartSleep and Bidirectional Video Support

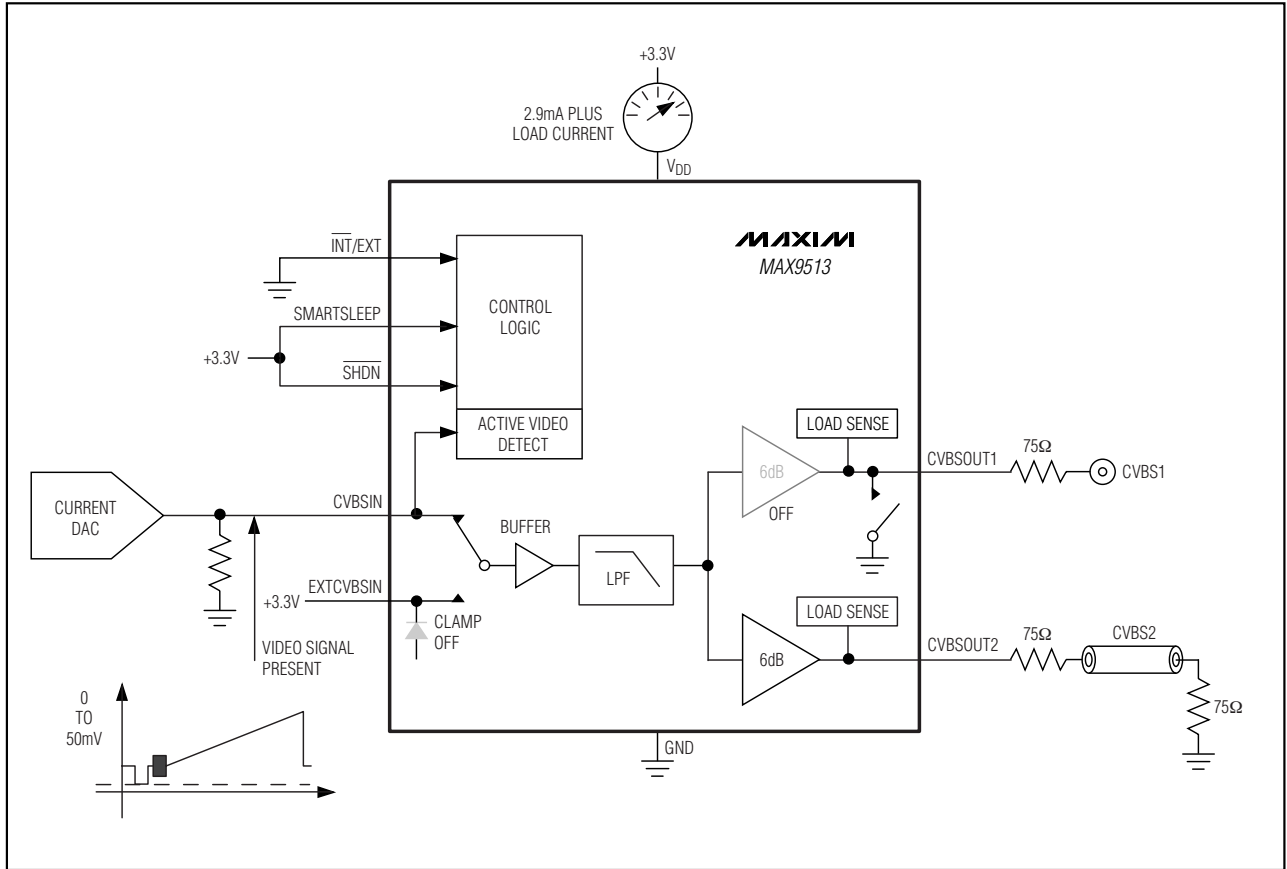

Figure 5. Full-Operation Mode with CVBSOUT2 Loaded

CVBS Video Filter Amplifier with SmartSleep and Bidirectional Video Support

MAX9513

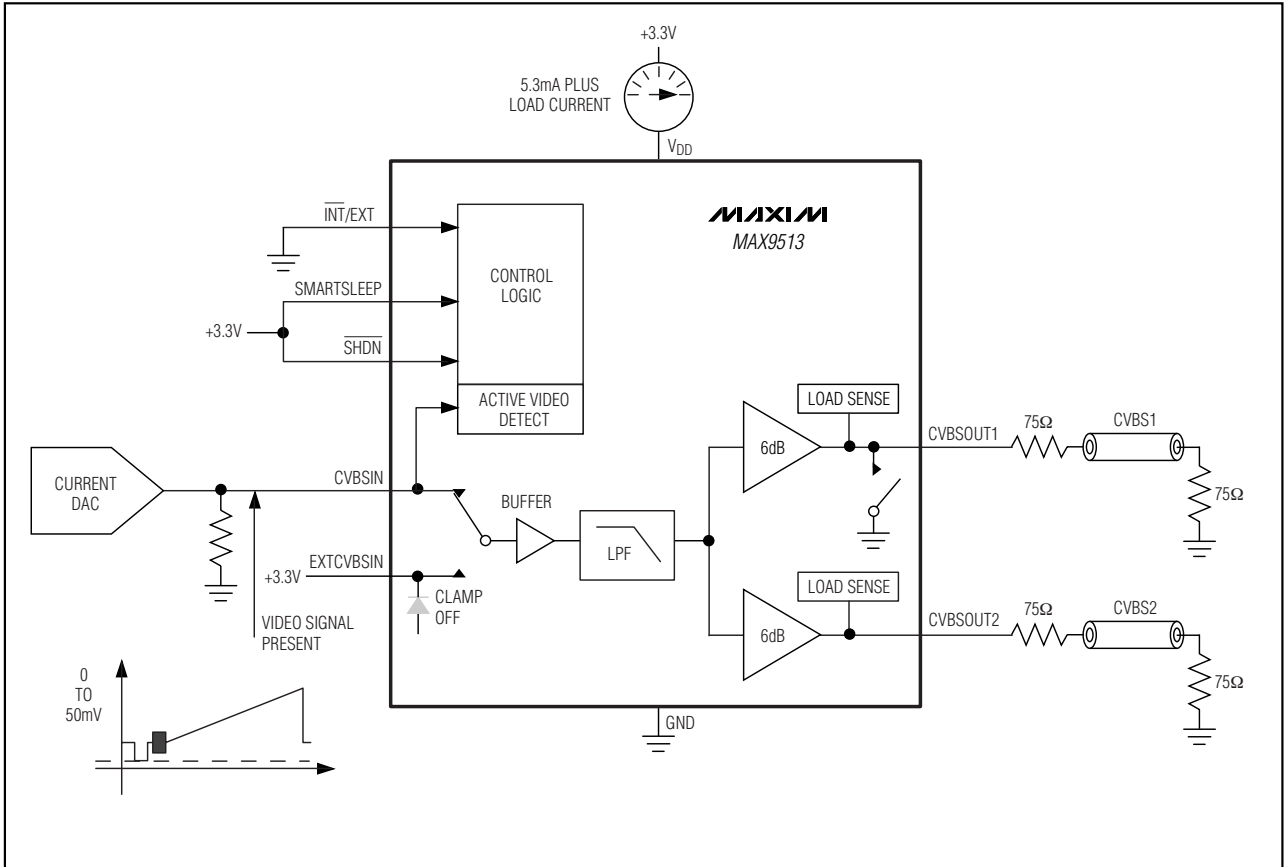

Figure 6. Full-Operation Mode with Both Outputs Loaded

CVBS Video Filter Amplifier with SmartSleep and Bidirectional Video Support

Internal Mode Versus External Mode

Internal Mode

Set the $\overline{\text{INT}}/\text{EXT}$ control input low for internal mode. The MAX9513 processes video signals from an internal source such as a DVD chip (Figure 7). The 2:1 multiplexer selects the video signal on CVBSIN. The EXTCVBSIN video signal is ignored.

External Mode

Set the $\overline{\text{INT}}/\text{EXT}$ control input high for external mode. The 2:1 multiplexer selects the video signal on EXTCVBSIN (Figure 8). The CVBSIN signal is ignored. The block drawing of the MAX9513 in Figure 8 shows which circuits are off while in external mode. SmartSleep does not function in external mode, and the SMARTSLEEP input is ignored.

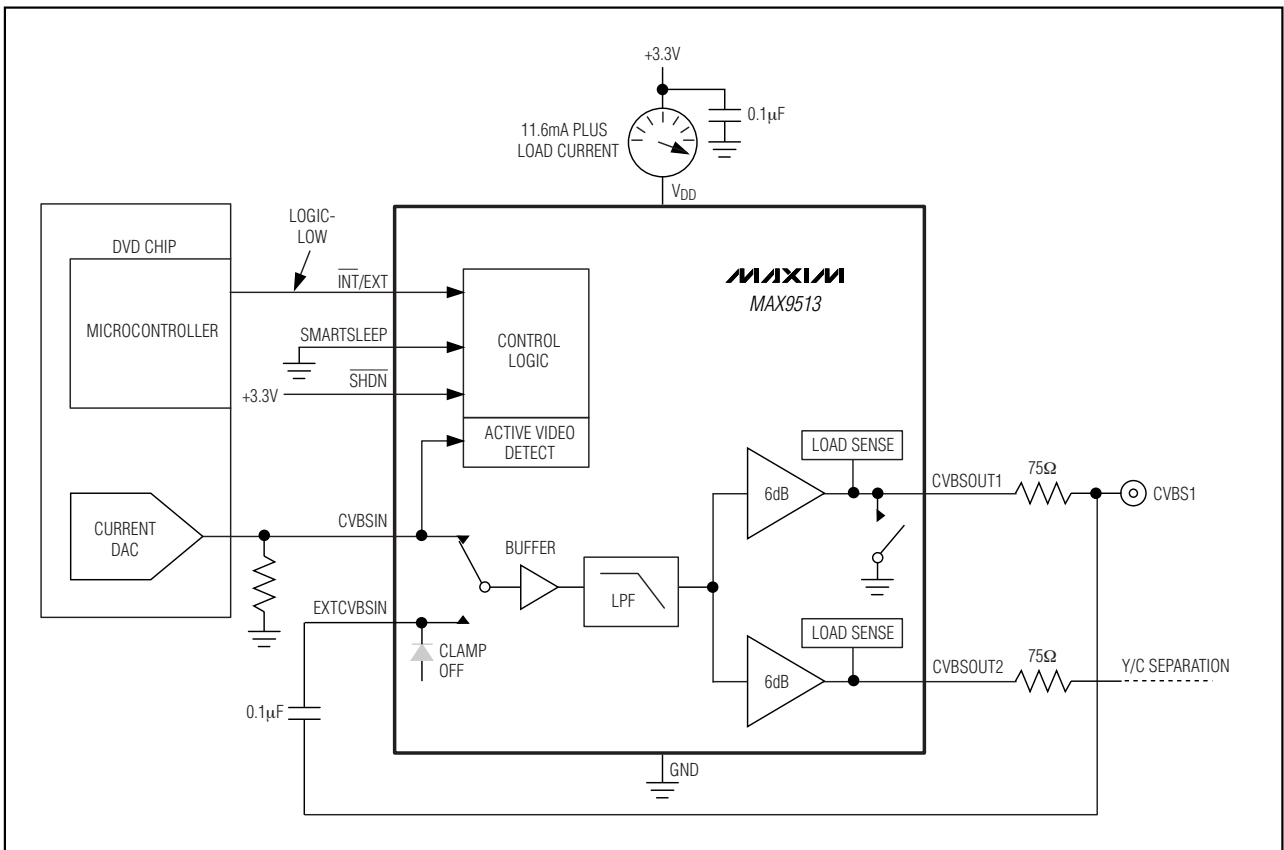

Figure 7. Internal Mode Operation for Portable DVD Application

CVBS Video Filter Amplifier with SmartSleep and Bidirectional Video Support

MAX9513

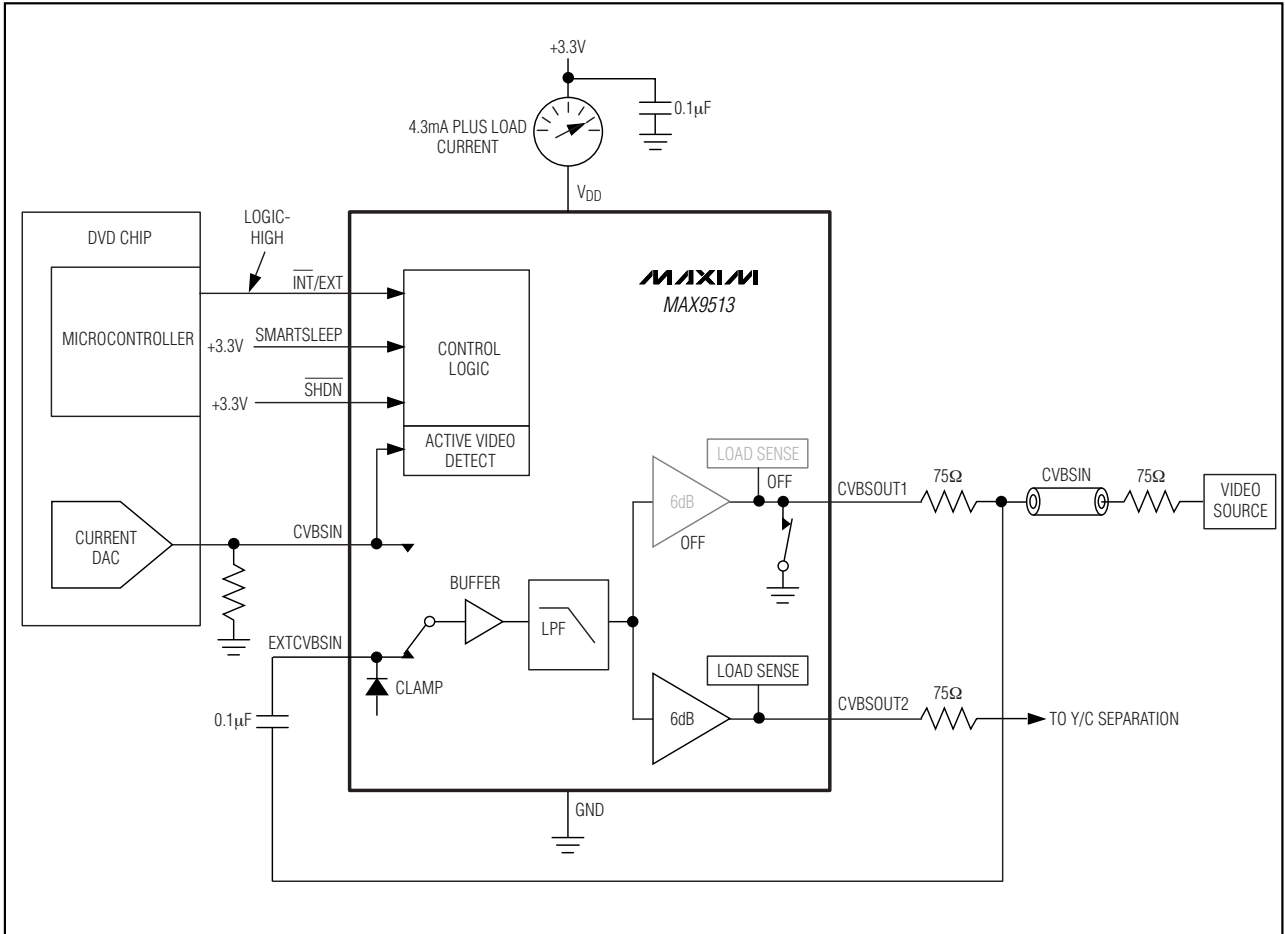

Figure 8. External Mode Operation for Portable DVD Application

CVBS Video Filter Amplifier with SmartSleep and Bidirectional Video Support

Inputs

The MAX9513 CVBSIN input should be directly connected to the output of the video current DAC. DC-coupling ensures that the input signals are ground referenced such that the sync tip of CVBSIN is within 50mV of ground.

The EXTCVBSIN input can only handle signals with a sync pulse, such as composite video and luma. Because the DC level of an external video input signal is unknown, the external video signal is AC-coupled through a 0.1 μ F capacitor, and a sync tip clamp sets the internal DC level of the MAX9513. A 2:1 multiplexer under the control of the INT/EXT input selects either the signal at CVBSIN or EXTCVBSIN.

Video Reconstruction Filter

The MAX9513 filter passband is 6.75MHz, which makes the device suitable for the higher bandwidth video signals from a DVD chip. Broadcast video signals actually require less bandwidth because of channel limitations: NTSC signals have a 4.2MHz bandwidth, and PAL signals have a 5MHz bandwidth. Video signals from a DVD player are not channel limited; therefore, the bandwidth of DVD video signals can push right against the Nyquist limit of 6.75MHz. (Recommendation ITU-R BT.601-5 specifies 13.5MHz as the sampling rate for standard-definition video). Therefore, the maximum bandwidth of the signal is 6.75MHz. To reduce the filtering requirements, most modern video systems oversample the input by two times, thus clocking the video current DAC at 27MHz.

Outputs

The video output amplifiers can both source and sink load current, allowing output loads to be DC- or AC-coupled. The amplifier output stage needs approximately 300mV of headroom from either supply rail. The MAX9513 has an internal level-shift circuit that positions the sync tip at approximately 300mV at the output.

If the supply voltage is greater than 3.135V (5% below a 3.3V supply), each amplifier can drive two DC-coupled video loads to ground. If the supply is less than 3.135V, each amplifier can drive only one DC-coupled or AC-coupled video load.

Shutdown

When $\overline{\text{SHDN}}$ is low, the MAX9513 typically draws less than 10nA supply current. All the amplifier outputs become high impedance. The effective output resistance at the video outputs is 28k Ω , due to the internal feedback resistors to ground.

Applications Information

Reducing Power Consumption in the Video DACs

CVBSIN has a high-impedance input buffer and can work with source resistances as high as 300 Ω . To reduce power dissipation in the video DACs, the DAC output resistor can be scaled up in value. The reference resistor that sets the reference current inside the video DACs must also be similarly scaled up. For instance, if the output resistor is 37.5 Ω , the DAC must source 26.7mA when the output is 1V. If the output resistor is increased to 300 Ω , the DAC only needs to source 3.33mA when the output is 1V.

There is parasitic capacitance from the DAC output to ground. That capacitance in parallel with the DAC output resistor forms a pole that can potentially roll off the frequency response of the video signal. For example, 300 Ω in parallel with 50pF creates a pole at 10.6MHz. To minimize this capacitance, reduce the area of the signal trace attached to the DAC output as much as possible, and place the MAX9513 as close to the video DAC outputs as possible.

AC-Coupling the Outputs

The outputs can be AC-coupled since the output stage can source and sink current as shown in Figure 9. Coupling capacitors should be 220 μ F or greater to keep the highpass filter formed by the 150 Ω equivalent resistance of the video transmission line to a corner frequency of 4.8Hz or below. The frame rate of PAL systems is 25Hz, and the frame rate of NTSC systems is 30Hz. The corner frequency should be well below the frame rate. SmartSleep only works with DC-coupled loads.

Power-Supply Bypassing and Ground

The MAX9513 operates from a single-supply voltage down to 2.7V, allowing for low-power operation. Bypass V_{DD} to GND with a 0.1 μ F capacitor. Place all external components as close as possible to the device.

CVBS Video Filter Amplifier with SmartSleep and Bidirectional Video Support

MAX9513

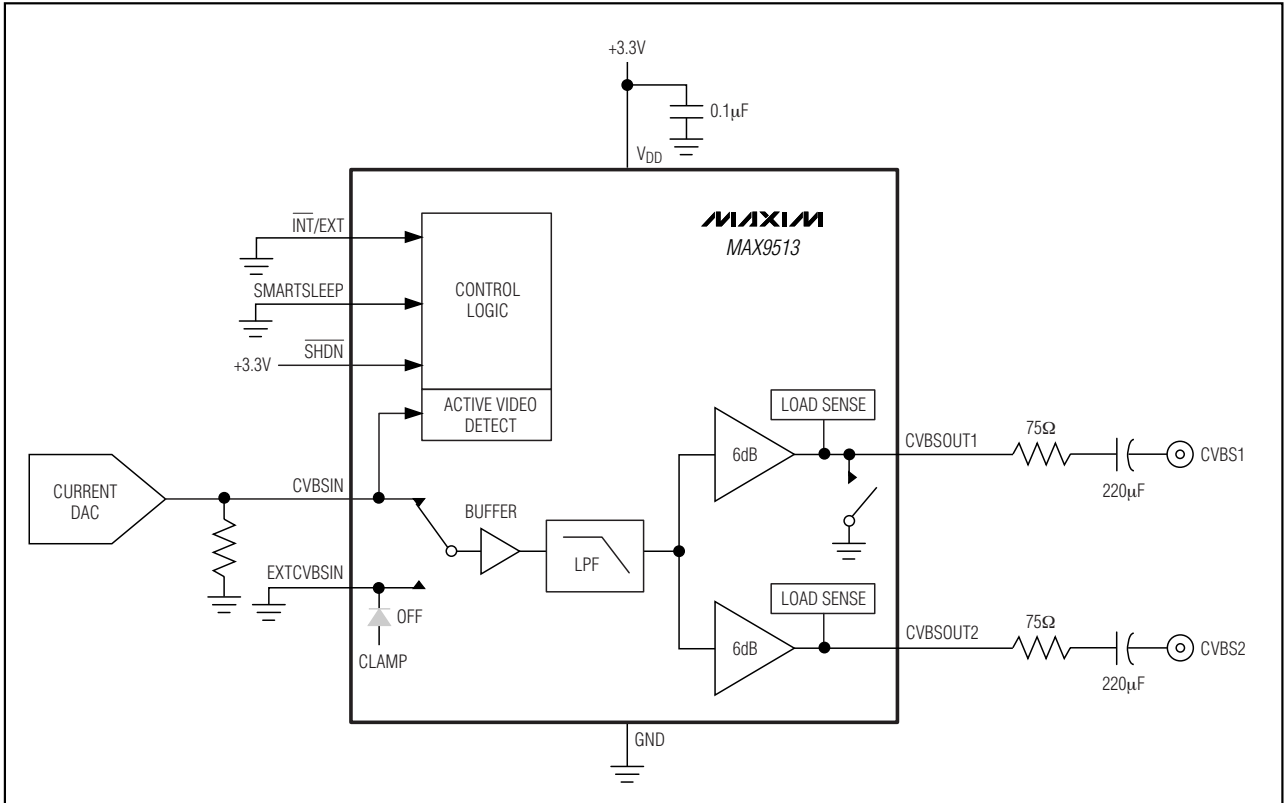
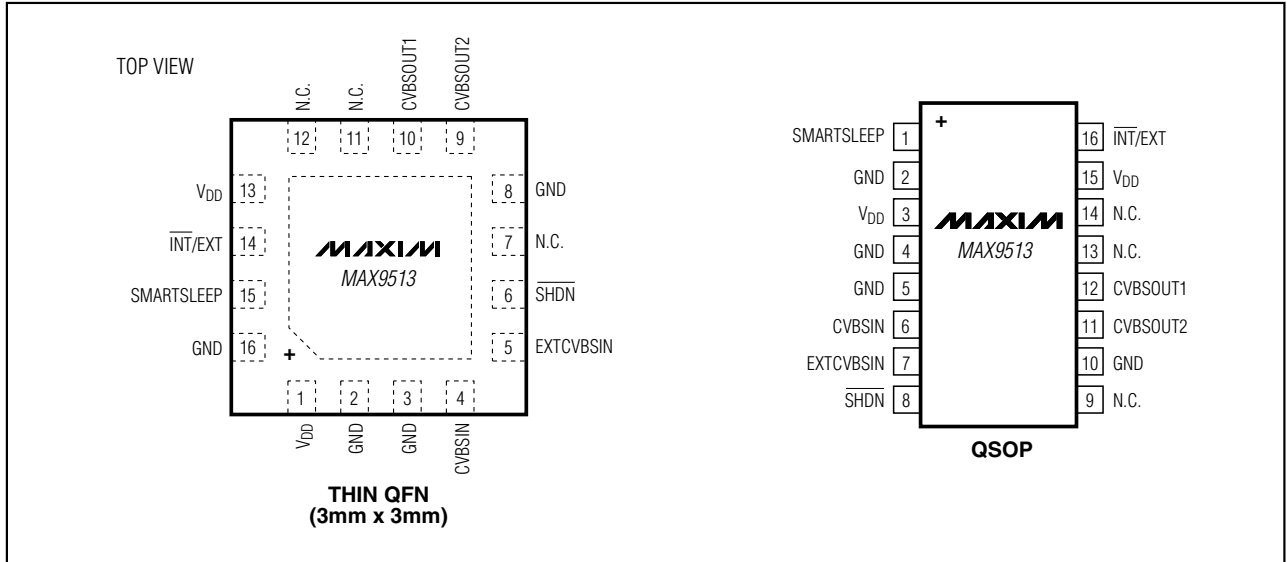

Figure 9. AC-Coupled Outputs

CVBS Video Filter Amplifier with SmartSleep and Bidirectional Video Support

Pin Configurations



Block Diagrams (continued)

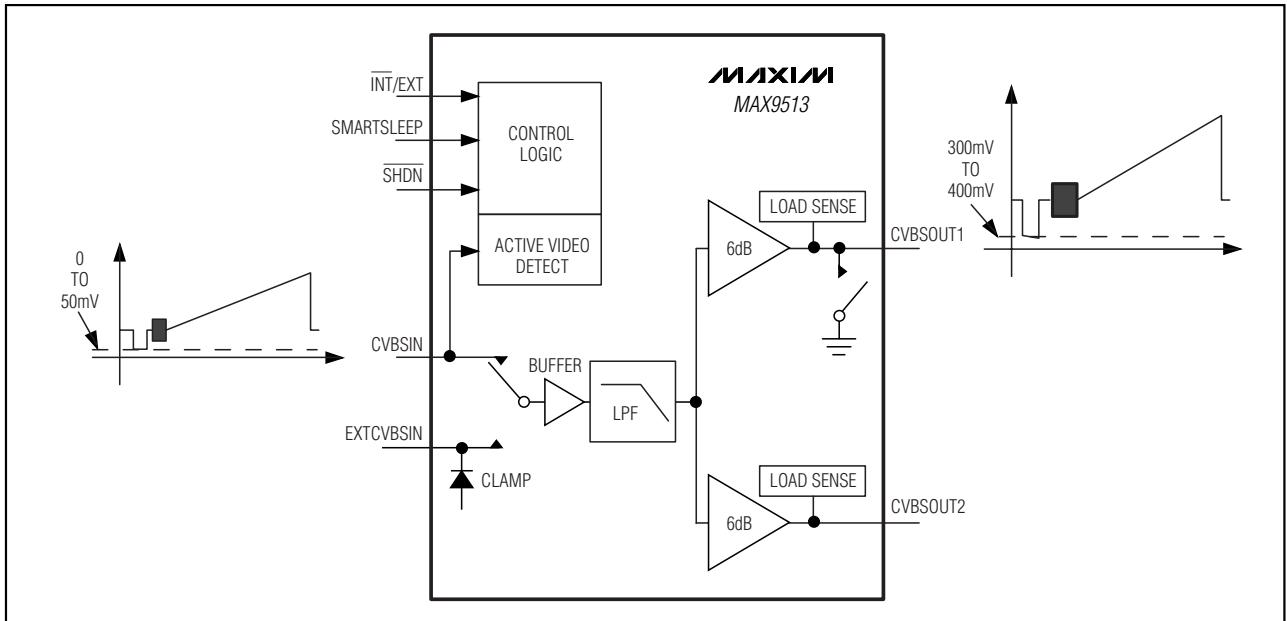

Chip Information

PROCESS: BICMOS

CVBS Video Filter Amplifier with SmartSleep and Bidirectional Video Support

Package Information

(The package drawing(s) in this data sheet may not reflect the most current specifications. For the latest package outline information, go to www.maxim-ic.com/packages.)

MAX9513

12x16L QFN THIN.EPS

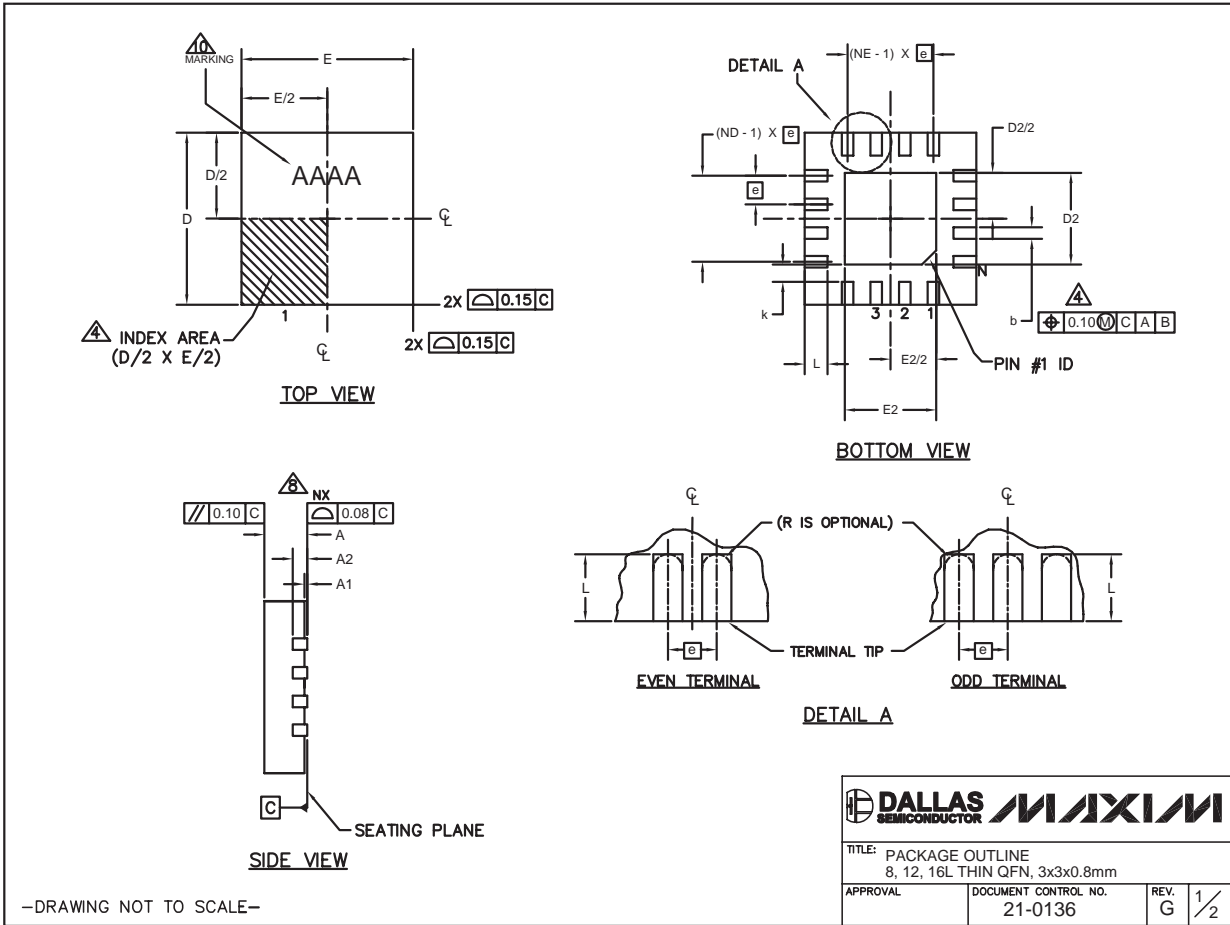

CVBS Video Filter Amplifier with SmartSleep and Bidirectional Video Support

Package Information (continued)

(The package drawing(s) in this data sheet may not reflect the most current specifications. For the latest package outline information, go to www.maxim-ic.com/packages.)

PKG	8L 3x3			12L 3x3			16L 3x3		
REF.	MIN.	NOM.	MAX.	MIN.	NOM.	MAX.	MIN.	NOM.	MAX.
A	0.70	0.75	0.80	0.70	0.75	0.80	0.70	0.75	0.80
b	0.25	0.30	0.35	0.20	0.25	0.30	0.20	0.25	0.30
D	2.90	3.00	3.10	2.90	3.00	3.10	2.90	3.00	3.10
E	2.90	3.00	3.10	2.90	3.00	3.10	2.90	3.00	3.10
e	0.65 BSC.			0.50 BSC.			0.50 BSC.		
L	0.35	0.55	0.75	0.45	0.55	0.65	0.30	0.40	0.50
N	8			12			16		
ND	2			3			4		
NE	2			3			4		
A1	0	0.02	0.05	0	0.02	0.05	0	0.02	0.05
A2	0.20 REF			0.20 REF			0.20 REF		
k	0.25	-	-	0.25	-	-	0.25	-	-

EXPOSED PAD VARIATIONS									
PKG. CODES	D2			E2			PIN ID	JEDEC	DOWN BONDS ALLOWED
	MIN.	NOM.	MAX.	MIN.	NOM.	MAX.			
TQ833-1	0.25	0.70	1.25	0.25	0.70	1.25	0.35 x 45°	WEEC	NO
T1233-1	0.95	1.10	1.25	0.95	1.10	1.25	0.35 x 45°	WEED-1	NO
T1233-3	0.95	1.10	1.25	0.95	1.10	1.25	0.35 x 45°	WEED-1	YES
T1233-4	0.95	1.10	1.25	0.95	1.10	1.25	0.35 x 45°	WEED-1	YES
T1633-1	0.95	1.10	1.25	0.95	1.10	1.25	0.35 x 45°	WEED-2	NO
T1633-2	0.95	1.10	1.25	0.95	1.10	1.25	0.35 x 45°	WEED-2	YES
T1633F-3	0.65	0.80	0.95	0.65	0.80	0.95	0.225 x 45°	WEED-2	N/A
T1633FH-3	0.65	0.80	0.95	0.65	0.80	0.95	0.225 x 45°	WEED-2	N/A
T1633-4	0.95	1.10	1.25	0.95	1.10	1.25	0.35 x 45°	WEED-2	NO

NOTES:

- DIMENSIONING & TOLERANCING CONFORM TO ASME Y14.5M-1994.
- ALL DIMENSIONS ARE IN MILLIMETERS. ANGLES ARE IN DEGREES.
- N IS THE TOTAL NUMBER OF TERMINALS.
- THE TERMINAL #1 IDENTIFIER AND TERMINAL NUMBERING CONVENTION SHALL CONFORM TO JESD 95-1 SPP-012. DETAILS OF TERMINAL #1 IDENTIFIER ARE OPTIONAL, BUT MUST BE LOCATED WITHIN THE ZONE INDICATED. THE TERMINAL #1 IDENTIFIER MAY BE EITHER A MOLD OR MARKED FEATURE.
- DIMENSION b APPLIES TO METALLIZED TERMINAL AND IS MEASURED BETWEEN 0.20 mm AND 0.25 mm FROM TERMINAL TIP.
- ND AND NE REFER TO THE NUMBER OF TERMINALS ON EACH D AND E SIDE RESPECTIVELY.
- DEPOPULATION IS POSSIBLE IN A SYMMETRICAL FASHION.
- COPLANARITY APPLIES TO THE EXPOSED HEAT SINK SLUG AS WELL AS THE TERMINALS.
- DRAWING CONFORMS TO JEDEC MO220 REVISION C.
- MARKING IS FOR PACKAGE ORIENTATION REFERENCE ONLY.
- NUMBER OF LEADS SHOWN ARE FOR REFERENCE ONLY.

—DRAWING NOT TO SCALE—

		
TITLE: PACKAGE OUTLINE 8, 12, 16L THIN QFN, 3x3x0.8mm		
APPROVAL	DOCUMENT CONTROL NO. 21-0136	REV. G 2/2

CVBS Video Filter Amplifier with SmartSleep and Bidirectional Video Support

Package Information (continued)

(The package drawing(s) in this data sheet may not reflect the most current specifications. For the latest package outline information, go to www.maxim-ic.com/packages.)

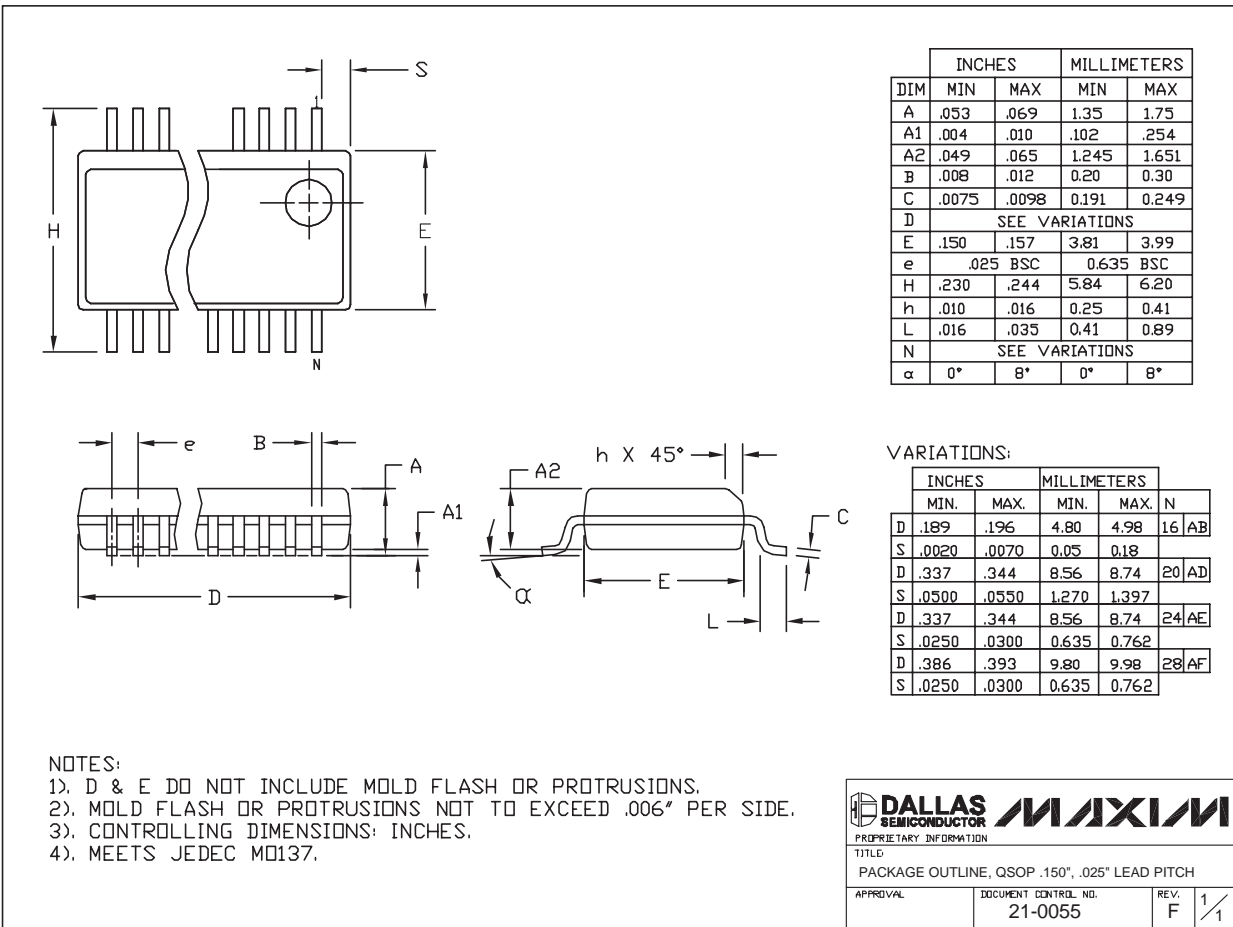

QSOPT.EFS

MAX9513

Maxim cannot assume responsibility for use of any circuitry other than circuitry entirely embodied in a Maxim product. No circuit patent licenses are implied. Maxim reserves the right to change the circuitry and specifications without notice at any time.

Maxim Integrated Products, 120 San Gabriel Drive, Sunnyvale, CA 94086 408-737-7600 23

© 2006 Maxim Integrated Products MAXIM is a registered trademark of Maxim Integrated Products, Inc.