

Integrated circuit of temperature sensor

IL135Z

Microcircuit IL135Z is precision temperature sensor with calibration capacity . Microcircuit operates as Zener diode with brake down voltage being in direct proportion to to absolute temperature (10 mV/°K). Full dynamic resistance of the circuit is less than 1 Ohm at operation current 450 μA...5 mA. The sensor calibrated at the temperature 25°C,has typical error less than 1°C in the temperature range above 100°C. The peculiarity of the circuit IL135Z is the linear dependence of output voltage versus temperature.

IC features

- calibration in °K
- initial measurement accuracy 1°K
- range of operating supply current from 450 μA to 5 mA
- Full dynamic resistance less than 1 Ohm

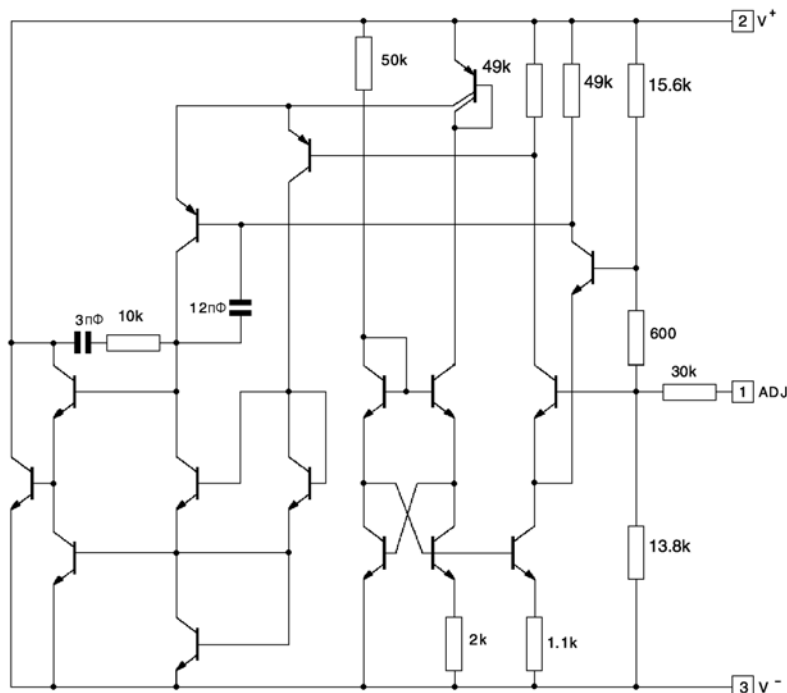
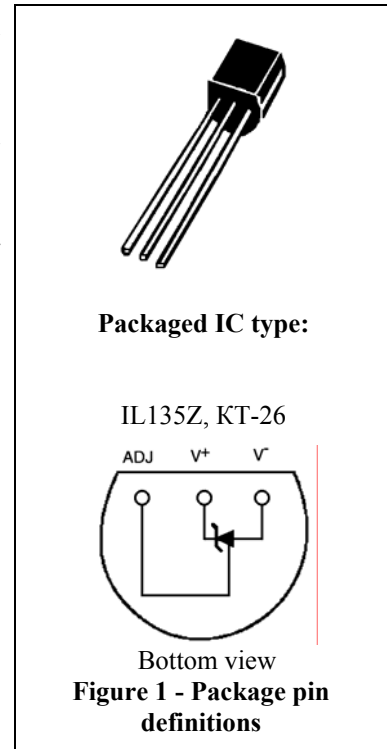


Figure 2 - circuitry IL135Z.

Table 1 - Maximum ratings

Name of parameter	Symbol	Standard		Unit of measurement
		min	max	
IC current reverse direct	I_R I_F	- --	15 10	mA
Air operation temperature: * - constant mode - short-time	T_{OPER}	- 55 150	150 200	°C
Storage temperature	T_{stg}	-65	150	°C

Note - $*T_j \leq 150^\circ\text{C}$

Table 2 – Temperature parameters.

Name of parameter	Symbol	Standard			Test conditions	Temperature °C	Unit
		min	Type	max			
output voltage, V	U_{OUT}	2,95	2,98	3,01	$I_R = 1 \text{ mA}$	25	V
Non-calibrated temperature error	ΔT_1	-	1 2	3 5	$I_R = 1 \text{ mA}$	25 -55 ÷ 150	°C
temperature error at calibration 25° C	ΔT_2	-	0,5	1,5	$I_R = 1 \text{ mA}$	-55 ÷ 150	°C
Calibrated error in extended temperature range	ΔT_3	-	2	-	$T_{case} = T_{max}$ periodical	-55 ÷ 150	°C
Non-linearity of temperature characteristic	ΔT_4	-	0,3	1	$I_R = 1 \text{ mA}$	-55 ÷ 150	°C

Table 3 – Electrical parameters.

Name of parameter	Symbol	Standard			Test conditions	Temperature °C	
		min	type.	max			
Measurement of output voltage in supply currents range	ΔU_{OUT}	-	2,5	10	$0,45 \text{ mA} \leq I_R \leq 5 \text{ mA}$	-55 ÷ 150	mV
Dynamic impedance	ΔR_1	-	0,5	-	$I_R = 1 \text{ mA}$	25	Ohm
Temperature coefficient of output voltage	TKH	-	+10	-	-	25	mV/°C
Time constant: -still air -speed of air is 0,5 m/c - agitated oil	τ_T	- - -	80 10 1	- - -	-	-55 ÷ 150	C
Time stability	T_{CTAB}	-	0,2	-	-	125	°C/ 1000ч

Note – Precise measurements done in agitated oil bath. For other conditions there should be taking into consideration self-heating .

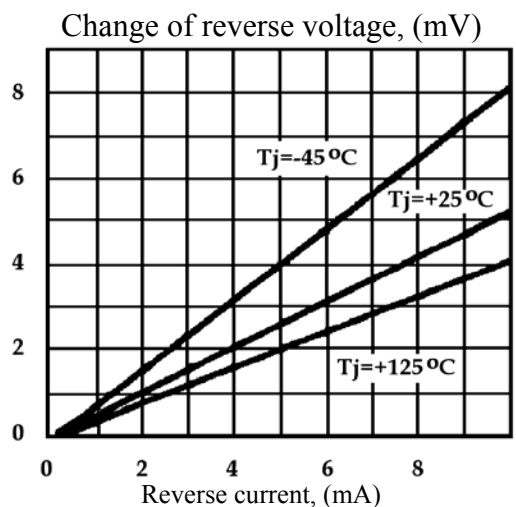


Figure 3 – Reverse voltage versus reverse current

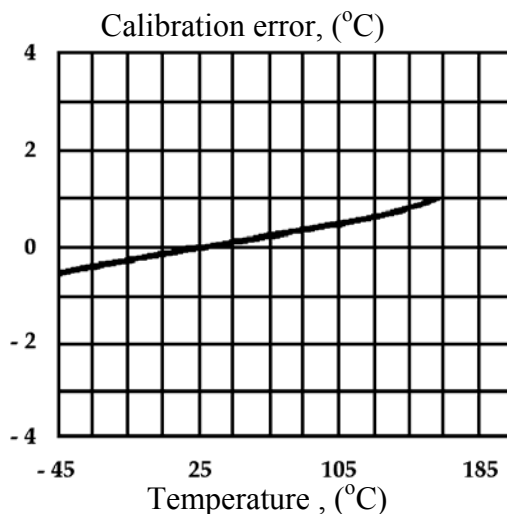


Figure 4 – Calibration error versus temperature

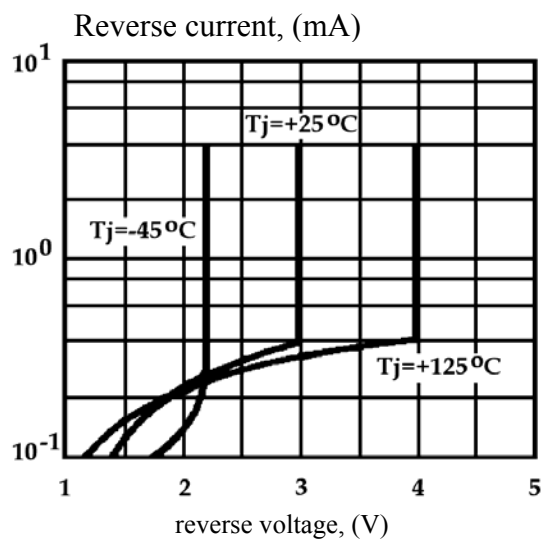


Figure 5 – Reverse current versus reverse voltage

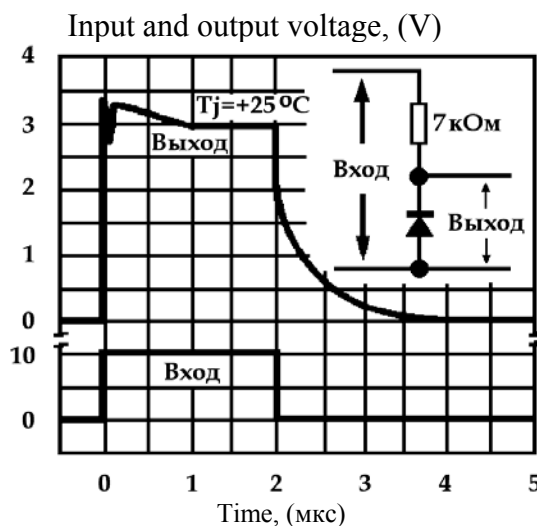


Figure 6 – Output signal response time

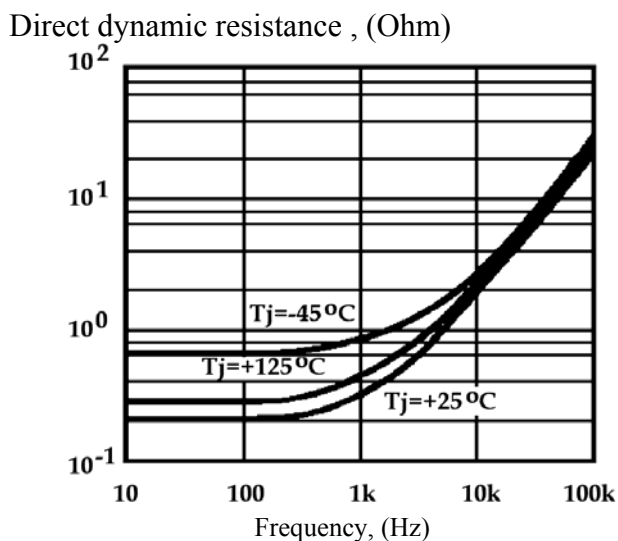


Figure 7 – Dynamic resistance versus frequency
Зависимость динамического сопротивления от частоты

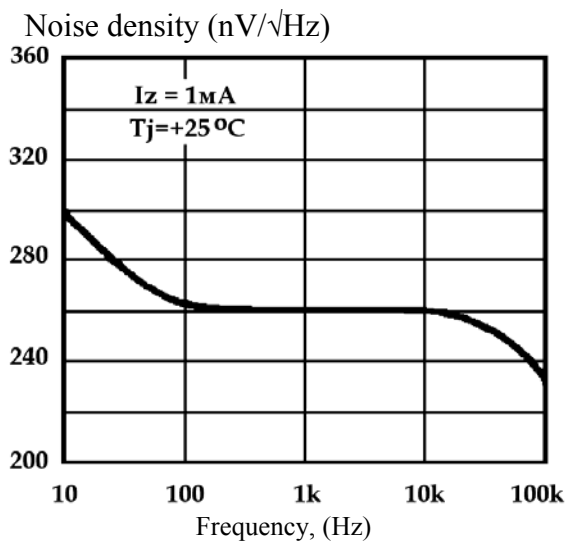


Figure 8 – Noise voltage

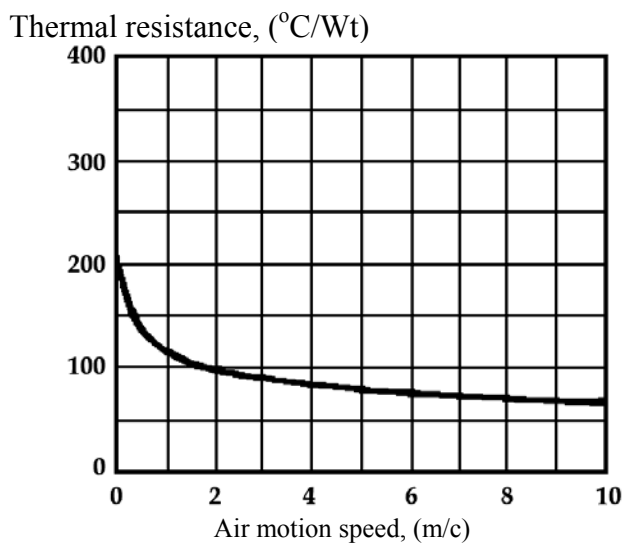


Figure 9 – Thermal resistance versus air motion speed

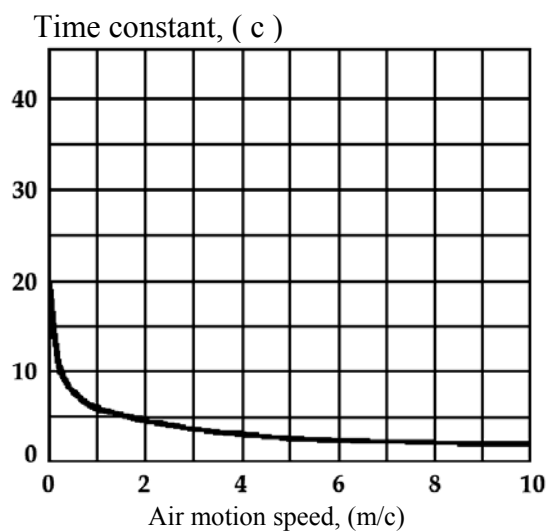


Figure 10 – Time constant versus air motion speed

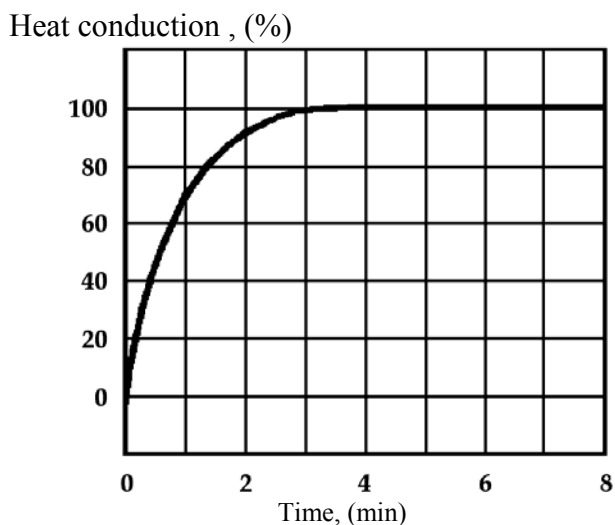


Figure 11 – Time dependence of heat conduction in still air

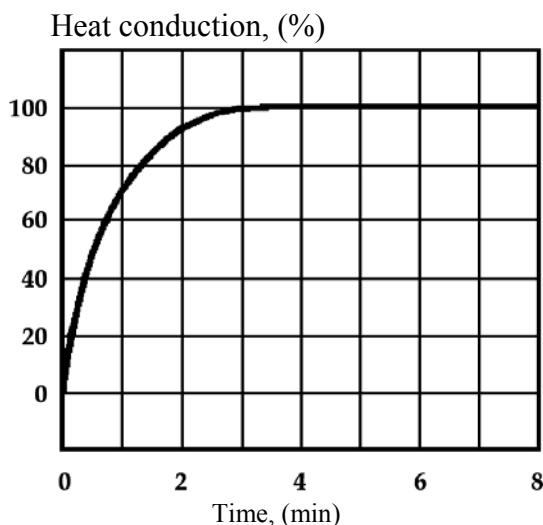


Figure 12 – Time dependence of heat conduction in agitated oil

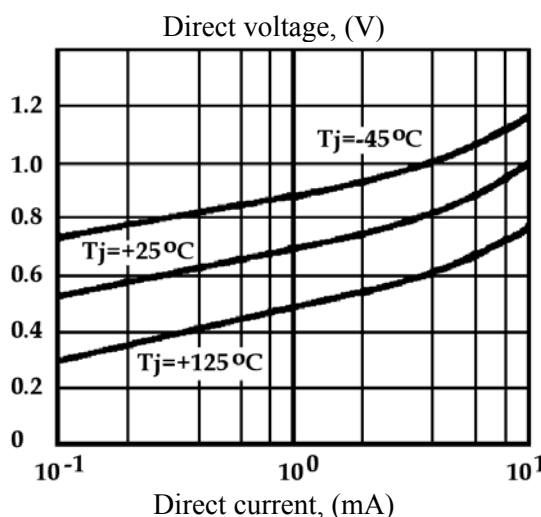


Figure 13 – Dependence of direct voltage on direct current

Information for application.

There is a simple technique of the device calibration for improving precision of temperature measurement (see typical application circuits).

Calibration of the device occurs in one spot as the IC output voltage is proportional to absolute temperature with sensor voltage extrapolation to 0 V at 0°K (-273,15°C). The errors in dependence of output voltage on temperature are determined only by characteristic incline. Therefore bias calibration at one temperature corrects errors in the whole temperature range. Output voltage of calibrated or non calibrated circuit may be derived from the following equation:

$$V_{OT} = VO_{TO} \frac{T}{T_0} ;$$

where T – unknown temperature;
 T₀ – reference temperature (in °K).

Nominally IC output calibrated to the value 10 mV/°K.

To ensure measurement precision they apply some rules. Degradation of the precision when self-heating is proper to any devices of temperature sensors. The circuit should operate at low operating current but sufficient for controlling the sensor and its calibration circuit at maximum operating temperature.

When using the sensor in the field with constant thermal resistance, error when self-heating may be reduced by external calibration. It can be done at the circuit bias when applying temperature-stabilized current. Thus heating will be proportional to Zener diode voltage. In this case error when self-heating is proportional to absolute temperature as the error of scaling coefficient.

Typical application circuits.

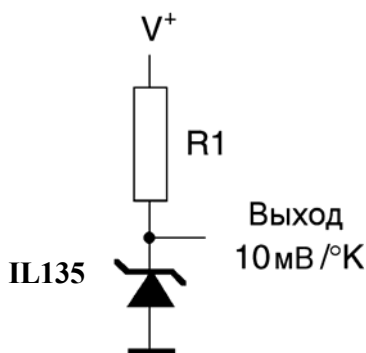


Figure 14 – Basic circuit of temperature sensor

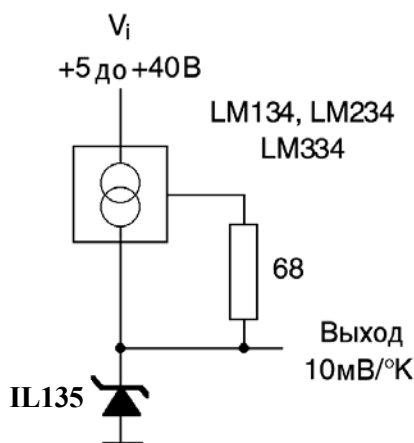


Рисунок 15 – Схема применения с широким диапазоном напряжения питания

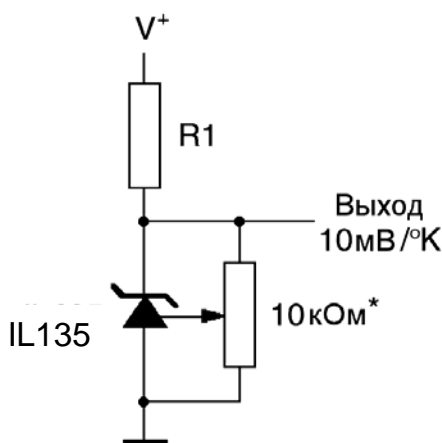


Figure 16 – Temperature sensor with external calibration *

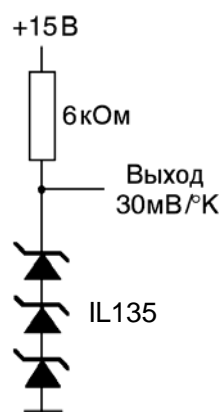


Figure 17 – Sequential sensor connection for increase of temperature bias voltage–

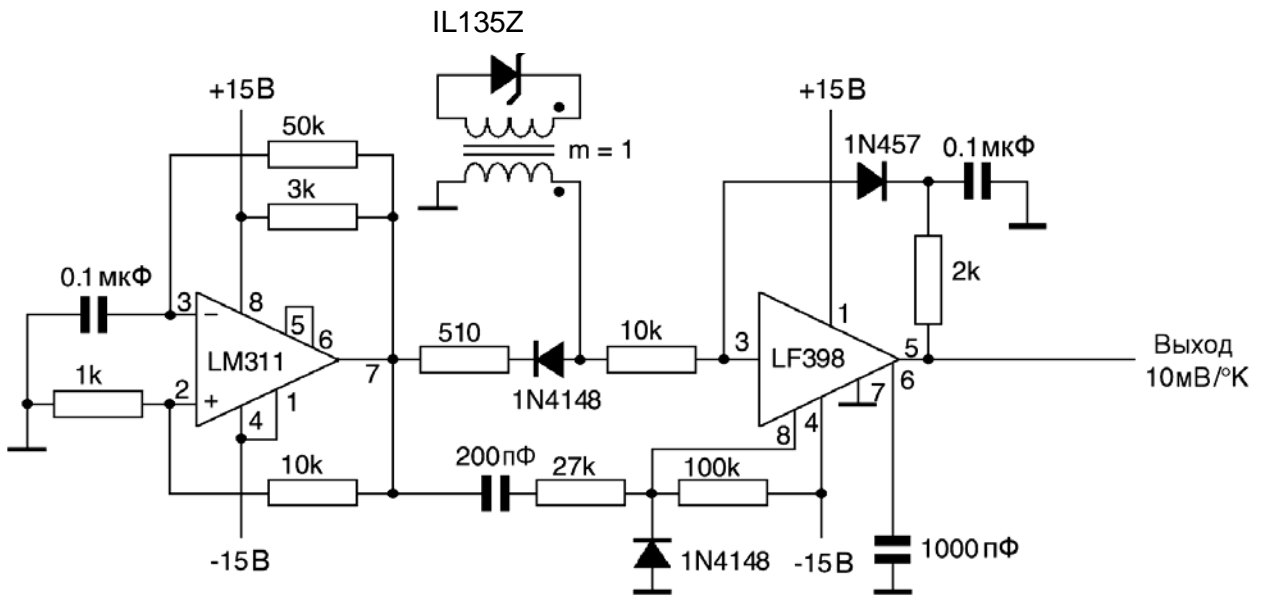


Figure 18 – Circuit of isolated temperature sensor

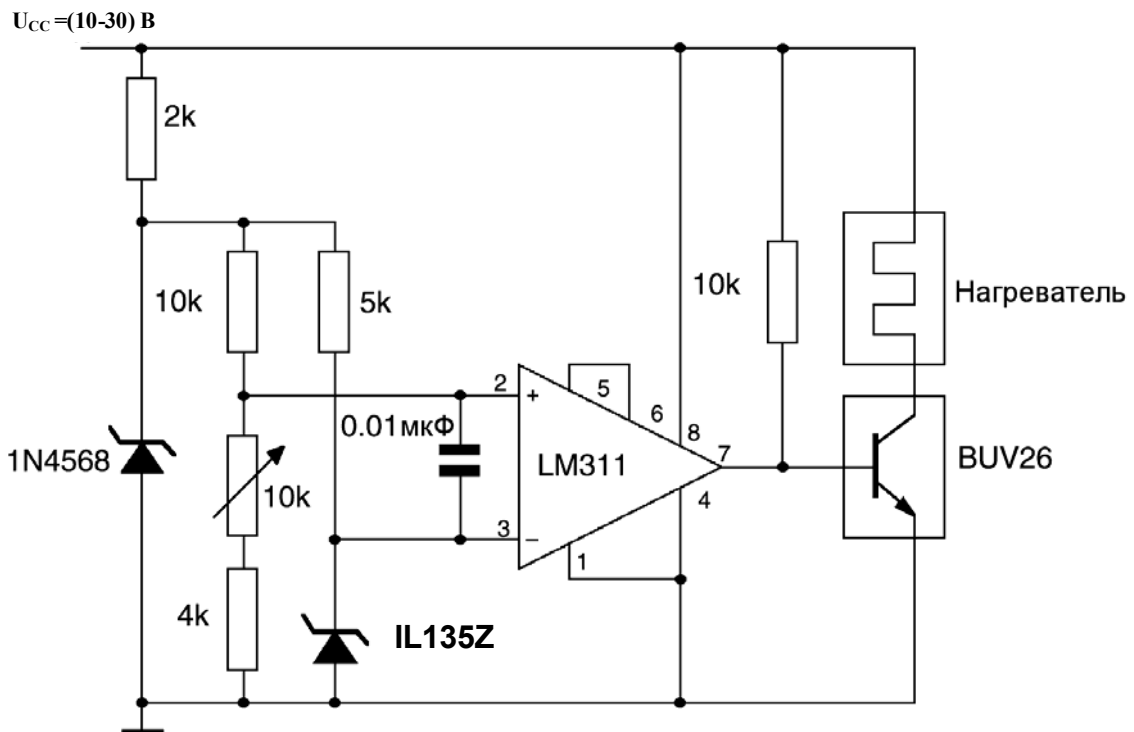


Figure 19 – Temperature regulator

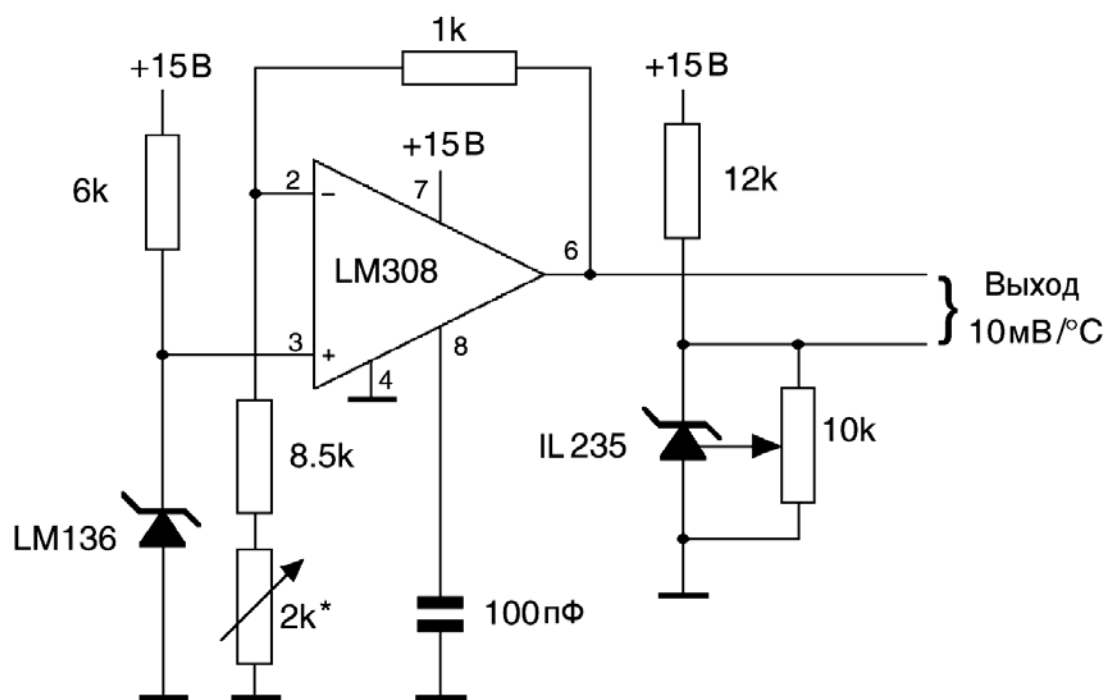


Figure 20 – Thermal sensor with 100° scale
 * Calibration for 2,7315 V on output of LM308

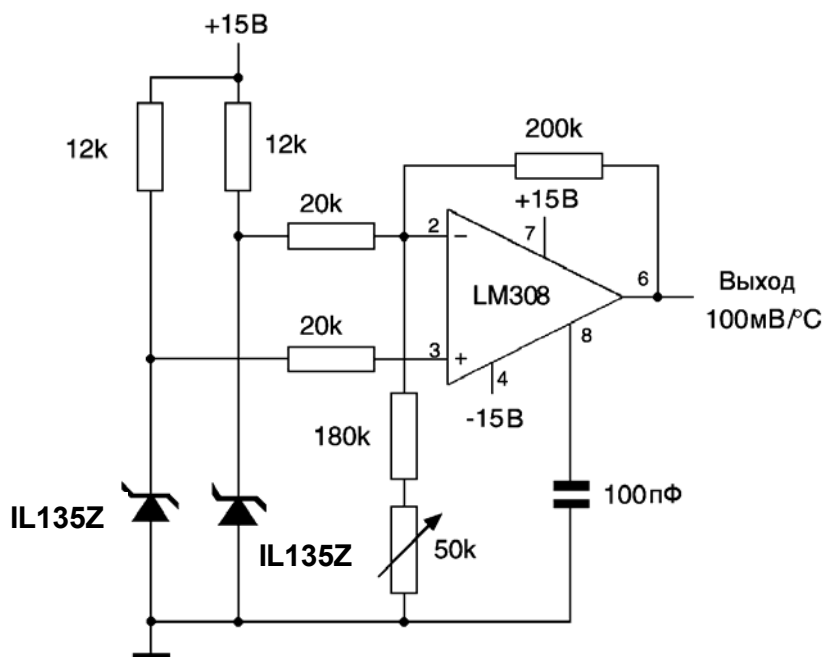
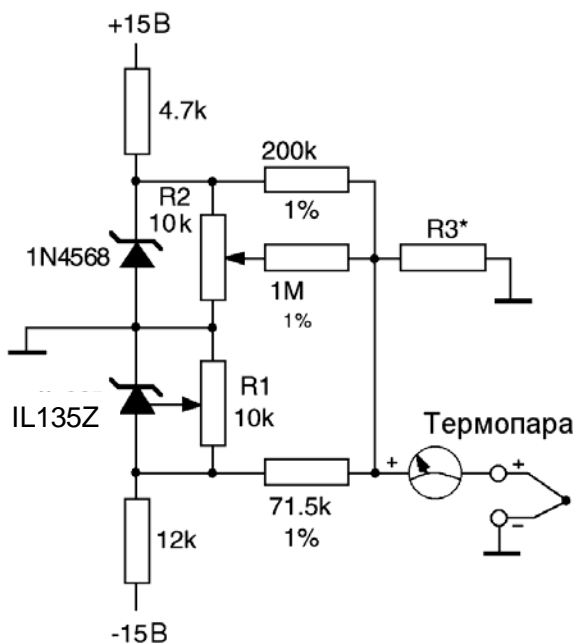


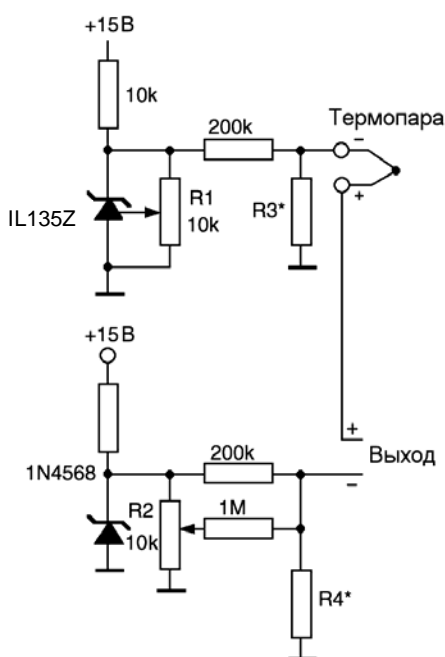
Figure 21 – Differential temperature sensor



Thermo couple	R3	Thermo electrical coefficient
J	377 Ohm	52,3 $\mu\text{V}/^\circ\text{C}$
T	308 Ohm	42,8 $\mu\text{V}/^\circ\text{C}$
K	293 Ohm	40,8 $\mu\text{V}/^\circ\text{C}$
S	45,8 Ohm	6,4 $\mu\text{V}/^\circ\text{C}$

Adjustment: compensation of sensor and resistor tolerances
 1 Selection of 1N4568
 2 Adjustment of voltage drop on element R3 by the resistor R1 to obtain the value of thermoelectrical coefficient, multiplied by the ambient temperature (in K degrees).
 3 Selection of IL135Z and adjustment of R2 for setting voltage drop on the element R3 according to thermocouple type
 J – 14,32 mV K – 11,17 mV
 T – 11,79 mV S – 1,768 mV

Figure 22 – Circuit of cold junction compensation (compensation for ground thermocouple)
 *Value of R3 nominal for this thermocouple type



Thermo-couple	R3	R4	Thermoelectrical coefficient
J	1050 Ohm	365 Ohm	52,3 $\mu\text{V}/^\circ\text{C}$
T	856 Ohm	315 Ohm	42,8 $\mu\text{V}/^\circ\text{C}$
K	816 Ohm	300 Ohm	40,8 $\mu\text{V}/^\circ\text{C}$
S	128 Ohm	46,3 Ohm	6,4 $\mu\text{V}/^\circ\text{C}$

Adjustment: compensation of sensor and resistor tolerances
 1 Adjustment by the resistor R1 for obtaining voltage drop on the element R3, equal to thermoelectrical coefficient multiplied by the ambient temperature (in K degrees)
 2 Adjustment of the resistor R2 for obtaining some voltage drop on the element R4 according to thermocouple type
 J – 14,32 mV K – 11,17 mV
 T – 11,79 mV S – 1,768 mV

Figure 23 – Circuit of cold junction compensation with unipolar supply
 *Value of R3 and R4 nominals for this thermocouple type

Package Dimensions

TO-92

