

## Silicon PNP Power Transistors

2SA1658

## DESCRIPTION

- With TO-220F package
- Complement to type 2SC4369
- Good linearity of  $h_{FE}$

## APPLICATIONS

- For general purpose applications

## PINNING

PIN	DESCRIPTION
1	Base
2	Collector
3	Emitter

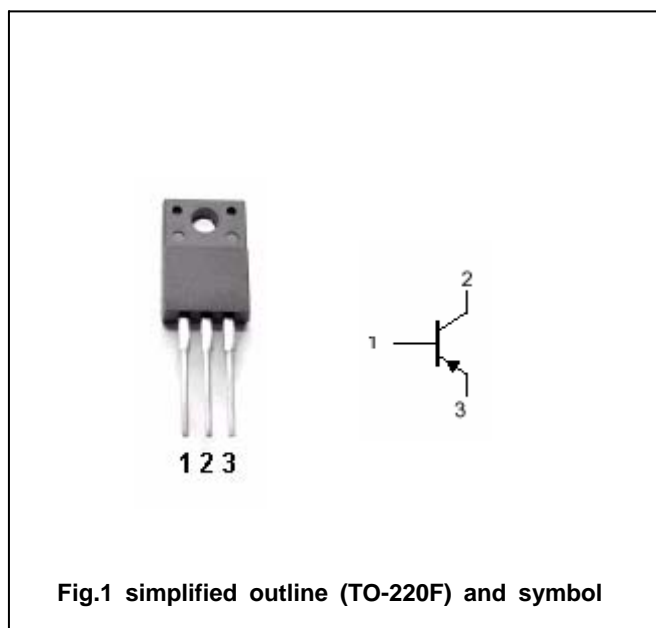
Absolute maximum ratings ( $T_a=25^{\circ}\text{C}$ )

SYMBOL	PARAMETER	CONDITIONS	VALUE	UNIT
$V_{CBO}$	Collector-base voltage	Open emitter	-30	V
$V_{CEO}$	Collector-emitter voltage	Open base	-30	V
$V_{EBO}$	Emitter-base voltage	Open collector	-5	V
$I_C$	Collector current		-3	A
$I_B$	Base current		-0.3	A
$P_C$	Collector dissipation	$T_C=25^{\circ}\text{C}$	15	W
$T_j$	Junction temperature		150	$^{\circ}\text{C}$
$T_{stg}$	Storage temperature		-55~150	$^{\circ}\text{C}$

## Silicon PNP Power Transistors

## 2SA1658

## CHARACTERISTICS

T<sub>j</sub>=25°C unless otherwise specified

SYMBOL	PARAMETER	CONDITIONS	MIN	TYP.	MAX	UNIT
V <sub>(BR)CEO</sub>	Collector-emitter breakdown voltage	I <sub>C</sub> =-10mA ; I <sub>B</sub> =0	-30			V
V <sub>CEsat</sub>	Collector-emitter saturation voltage	I <sub>C</sub> =-2A ; I <sub>B</sub> =-0.2A		-0.3	-0.8	V
V <sub>BE</sub>	Base-emitter on voltage	I <sub>C</sub> =-0.5A ; V <sub>CE</sub> =-2V		-0.75	-1.0	V
I <sub>CBO</sub>	Collector cut-off current	V <sub>CB</sub> =-20V ; I <sub>E</sub> =0			-1.0	μ A
I <sub>EBO</sub>	Emitter cut-off current	V <sub>EB</sub> =-5V ; I <sub>C</sub> =0			-1.0	μ A
h <sub>FE-1</sub>	DC current gain	I <sub>C</sub> =-0.5A ; V <sub>CE</sub> =-2V	70		240	
h <sub>FE-2</sub>	DC current gain	I <sub>C</sub> =-2.5A ; V <sub>CE</sub> =-2V	25			
C <sub>OB</sub>	Output capacitance	I <sub>E</sub> =0 ; V <sub>CB</sub> =-10V ; f=1MHz		40		pF
f <sub>T</sub>	Transition frequency	I <sub>C</sub> =-0.5A ; V <sub>CE</sub> =-2V		100		MHz

◆ h<sub>FE-1</sub> Classifications

O	Y
70-140	120-240

Silicon PNP Power Transistors

2SA1658

PACKAGE OUTLINE

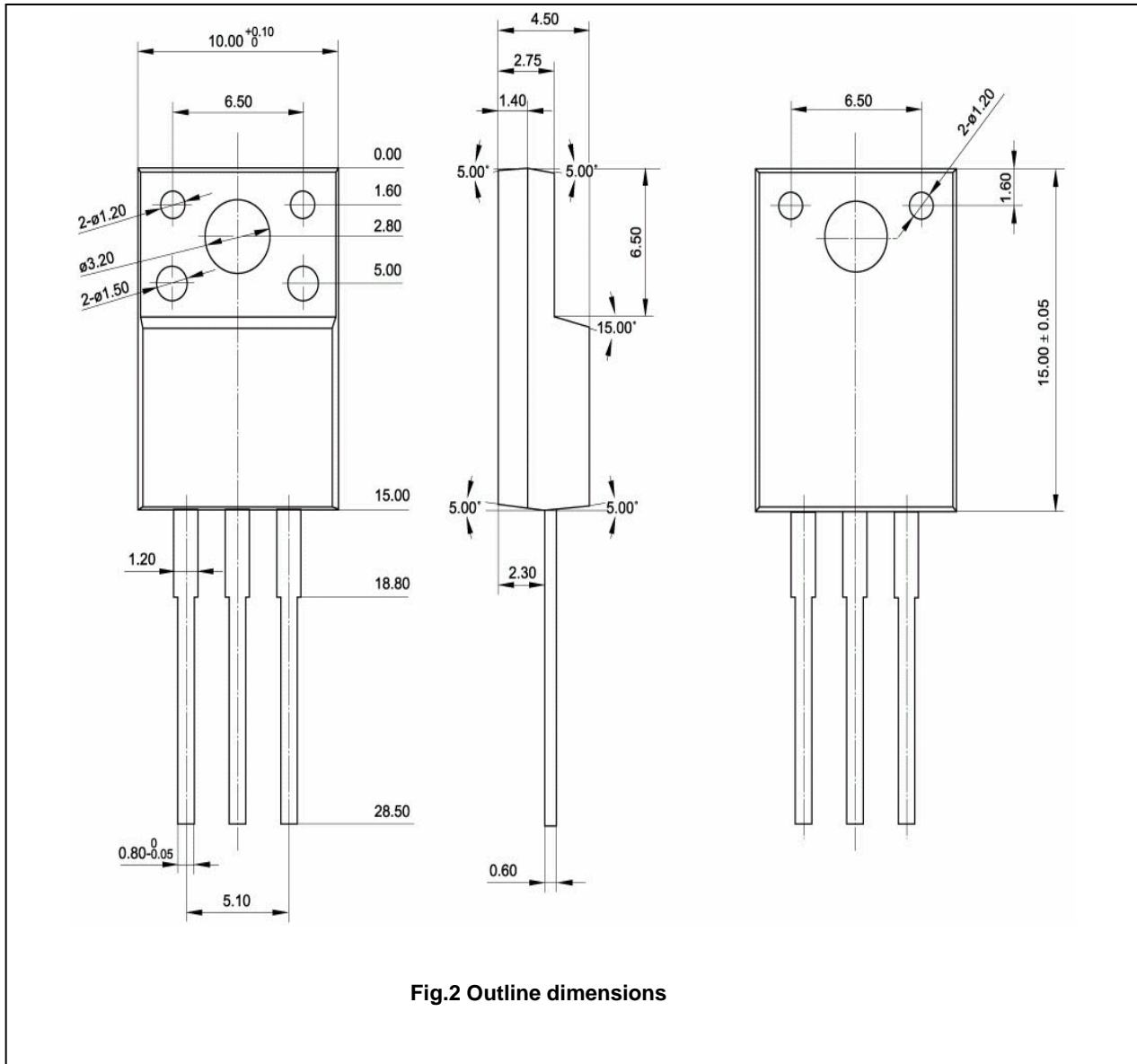

Fig.2 Outline dimensions