



TDF8553J

I²C-bus controlled 4 × 50 Watt power amplifier and multiple voltage regulator

Rev. 01 — 3 December 2008

Objective data sheet

1. General description

1.1 Amplifiers

The TDF8553 has a complementary quad audio power amplifier that uses BCDMOS technology. It contains four amplifiers configured in Bridge Tied Load (BTL) to drive speakers for front and rear left and right channels. The I²C-bus allows diagnostic information of each amplifier and its speaker to be read separately. Both front and both rear channel amplifiers can be configured independently in line driver mode with a gain of 20 dB (differential output) or amplifier mode with a gain of 26 dB (BTL output).

1.2 Voltage regulators

The TDF8553 has a multiple output voltage regulator with two power switches.

The voltage regulator contains the following:

- Four switchable regulators and two standby regulators
- Two power switches with loss-of-ground protection and surge protection
- Second supply pin to reduce dissipation by means of an external DC-to-DC converter

2. Features

- Amplifiers
 - ◆ I²C-bus control
 - ◆ Can drive a 2 Ω load with a battery voltage of up to 16 V and a 4 Ω load with a battery voltage of up to 18 V
 - ◆ DC load detection, open, short and present
 - ◆ AC load (tweeter) detection
 - ◆ Programmable clip detect; 1 % or 4 %
 - ◆ Programmable thermal protection pre-warning
 - ◆ Independent short-circuit protection per channel
 - ◆ Selectable line driver (20 dB) and amplifier mode (26 dB)
 - ◆ Loss-of-ground and open V_P safe
 - ◆ All outputs protected from short-circuit to ground, to V_P or across the load
 - ◆ All pins protected from short-circuit to ground
 - ◆ Soft thermal-clipping to prevent audio holes
 - ◆ Low battery detection

- Voltage regulators
 - ◆ I²C-bus control
 - ◆ Good stability for any regulator with almost any output capacitor value
 - ◆ Six voltage regulators (microcontroller, display, audio processor, tuner, bus, mechanical digital and drive)
 - ◆ Selectable output voltages for regulators 1, 4 and 5
 - ◆ Low dropout voltage PNP output stages
 - ◆ High supply voltage ripple rejection
 - ◆ Low noise for all regulators
 - ◆ Two power switches (antenna switch and amplifier switch)
 - ◆ Standby regulators 2 and 6 (microcontroller and bus supply) operational during load dump and thermal shut-down
 - ◆ Low standby quiescent current (only regulators 2 and 6 operational)
 - ◆ Second supply pin for connecting optional external DC-to-DC converter to reduce internal dissipation
 - ◆ Backup functionality for regulator 2
- Protection
 - ◆ If connection to the battery voltage is reversed, all regulator voltages will be zero
 - ◆ Able to withstand output voltages up to 18 V (supply line may be short-circuited)
 - ◆ Thermal protection to avoid thermal breakdown
 - ◆ Load-dump protection
 - ◆ Regulator outputs protected from DC short-circuit to ground or to supply voltage
 - ◆ All regulators protected by foldback current limiting
 - ◆ Power switches protected from loss-of-ground and surge conditions

3. Applications

- Boost amplifier and voltage regulator for car radios and CD/MD players

4. Quick reference data

Table 1. Quick reference data

Symbol	Parameter	Conditions	Min	Typ	Max	Unit
Amplifiers						
V _{P(oper)}	operating supply voltage	R _L = 4 Ω	8	14.4	18	V
I _{q(tot)}	total quiescent current	no load	-	280	400	mA
P _{O(max)}	maximum output power	R _L = 4 Ω; V _P = 14.4 V; V _{IN} = 2 V RMS square wave	44	46	-	W
		R _L = 4 Ω; V _P = 15.2 V; V _{IN} = 2 V RMS square wave	49	52	-	W
		R _L = 2 Ω; V _P = 14.4 V; V _{IN} = 2 V RMS square wave	83	87	-	W
THD	total harmonic distortion	P _O = 1 W to 12 W; f = 1 kHz; R _L = 4 Ω	-	0.01	0.1	%
V _{n(o)}	output noise voltage	filter 20 Hz to 22 kHz; R _S = 600 Ω				
		line driver mode	-	25	35	μV
		amplifier mode	-	50	70	μV

Table 1. Quick reference data ...continued

Symbol	Parameter	Conditions	Min	Typ	Max	Unit
Voltage regulators						
V _P	supply voltage	regulators 1, 3, 4 and 5 on; switches 1 and 2 on	10	14.4	18	V
		jump starts for t ≤ 10 minutes	-	-	30	V
		load dump protection for t ≤ 50 ms and t _r ≥ 2.5 ms	-	-	50	V
V _{th(dis)}	disable threshold voltage	regulator 1, 3, 4 and 5 on; switches 1 and 2 on	18.1	22	-	V
V _{DCDC}	DC-to-DC converter voltage		4.75	5.0	V _P	V
I _{q(tot)}	total quiescent current	standby mode; V _P = 14.4 V	-	180	250	μA
V _{O(reg)}	regulator output voltage	regulator 1; 0.5 mA ≤ I _O ≤ 400 mA; 10 V ≤ V _P ≤ 18 V; selectable via I ² C-bus				
		IB2[D3:D2] = 01	7.9	8.3	8.7	V
		IB2[D3:D2] = 10	8.1	8.6	9.1	V
		IB2[D3:D2] = 11	4.75	5.0	5.25	V
		regulator 2; 0.5 mA ≤ I _O ≤ 350 mA; 10 V ≤ V _P ≤ 18 V	3.1	3.3	3.5	V
		regulator 3; 0.5 mA ≤ I _O ≤ 500 mA; 5 V ≤ V _{DCDC} ≤ 18 V	3.1	3.3	3.5	V
		regulator 4; 0.5 mA ≤ I _O ≤ 800 mA; 10 V ≤ V _P ≤ 18 V; selectable via I ² C-bus				
		IB2[D7:D5] = 001	4.75	5.0	5.25	V
		IB2[D7:D5] = 010	5.7	6.0	6.3	V
		IB2[D7:D5] = 011	6.6	7.0	7.4	V
		IB2[D7:D5] = 100	8.1	8.6	9.1	V
		IB2[D7:D5] = 101	7.6	8.0	8.4	V
		regulator 5; 0.5 mA ≤ I _O ≤ 400 mA; selectable via I ² C-bus				
		10 V ≤ V _P ≤ 18 V; IB1[D7:D4] = 0001	5.7	6.0	6.3	V
		10 V ≤ V _P ≤ 18 V; IB1[D7:D4] = 0010	6.65	7.0	7.37	V
		10 V ≤ V _P ≤ 18 V; IB1[D7:D4] = 0011	7.8	8.2	8.6	V
		10.5 V ≤ V _P ≤ 18 V; IB1[D7:D4] = 0100	8.55	9.0	9.45	V
		11 V ≤ V _P ≤ 18 V; IB1[D7:D4] = 0101	9.0	9.5	10.0	V
		11.5 V ≤ V _P ≤ 18 V; IB1[D7:D4] = 0110	9.5	10.0	10.5	V
		13 V ≤ V _P ≤ 18 V; IB1[D7:D4] = 0111	9.9	10.4	10.9	V
		14.2 V ≤ V _P ≤ 18 V; IB1[D7:D4] = 1000	11.8	12.5	13.2	V
		12.5 V ≤ V _P ≤ 18 V; IB1[D7:D4] = 1001	V _P - 1	V _P - 0.5	-	V
		10 V ≤ V _P ≤ 18 V; IB1[D7:D4] = 1010	4.75	5.0	5.25	V
10 V ≤ V _P ≤ 18 V; IB1[D7:D4] = 1011	3.1	3.3	3.5	V		
regulator 6; 0.5 mA ≤ I _O ≤ 100 mA; 10 V ≤ V _P ≤ 18 V	4.75	5.0	5.25	V		
Power switches						
V _{do}	dropout voltage	switch 1; I _O = 400 mA	-	0.6	1.1	V
		switch 2; I _O = 400 mA	-	0.6	1.1	V

5. Ordering information

Table 2. Ordering information

Type number	Package		
	Name	Description	Version
TDF8553J	DBS37P	plastic DIL-bent-SIL power package; 37 leads (lead length 6.8 mm)	SOT725-1

6. Block diagram

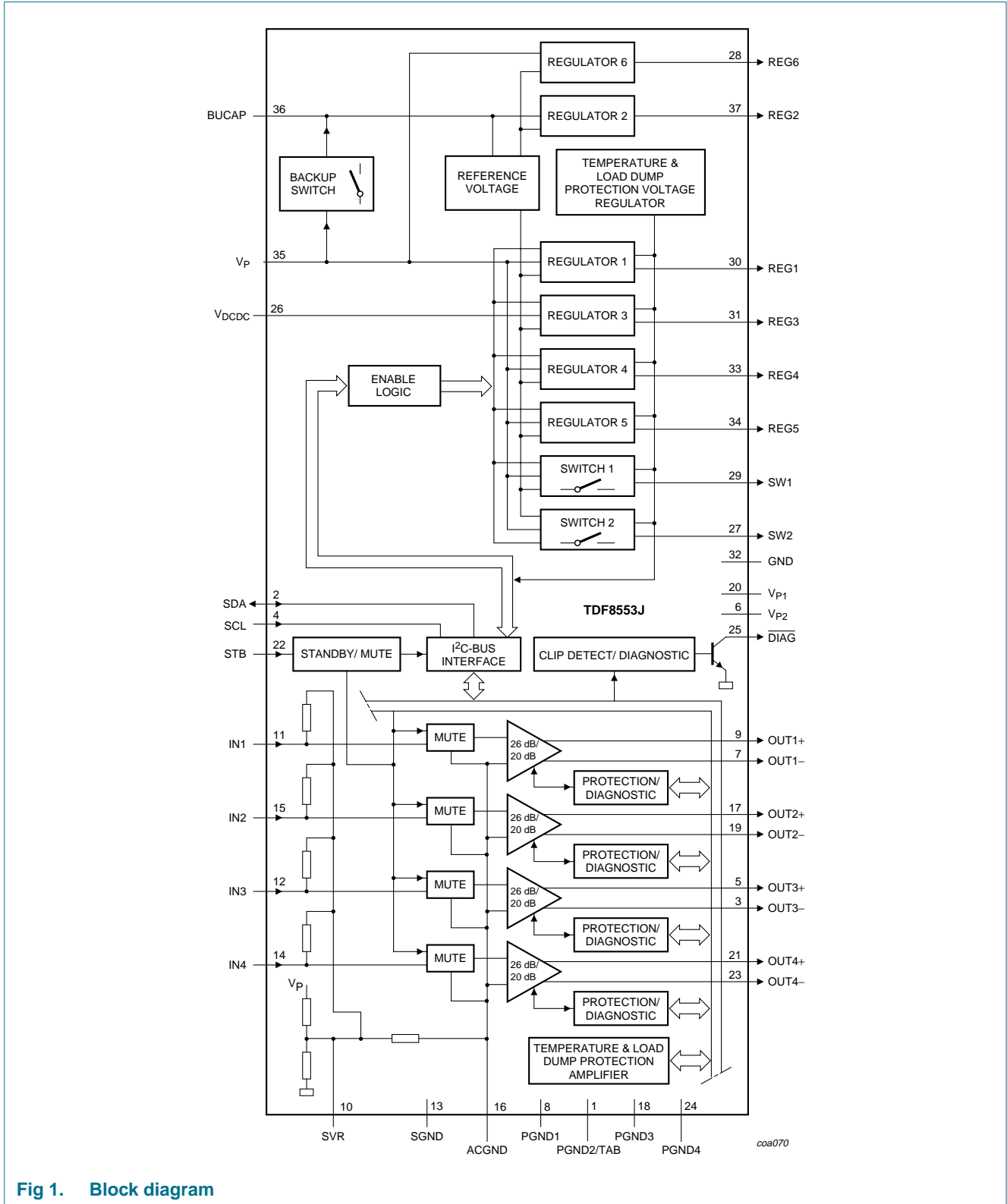

Fig 1. Block diagram

7. Pinning information

7.1 Pinning

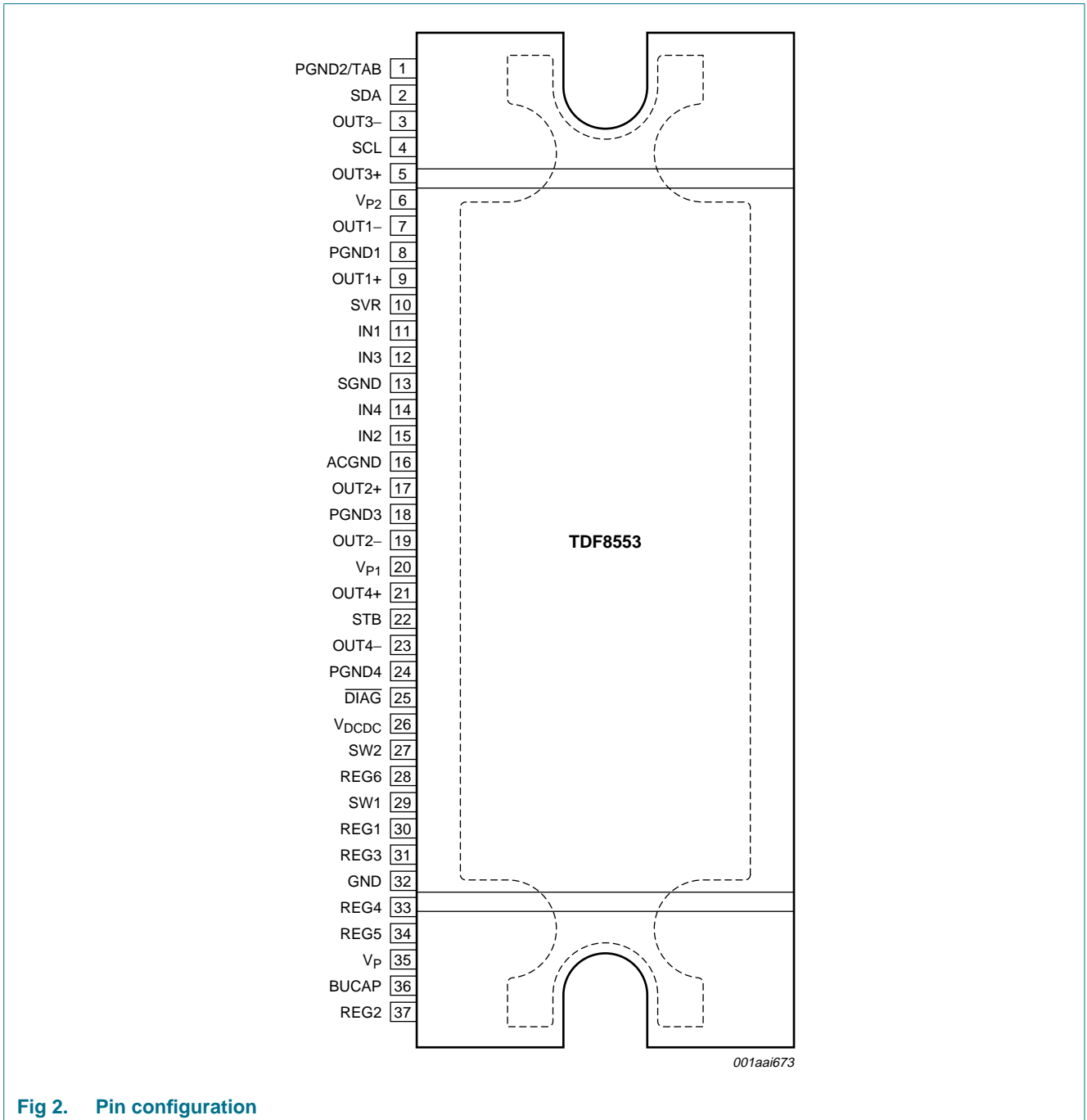

Fig 2. Pin configuration

7.2 Pin description

Table 3. Pin description

Symbol	Pin	Description
PGND/TAB	1	power ground 2 and connection for heatsink
SDA	2	I ² C-bus data input and output
OUT3-	3	channel 3 negative output
SCL	4	I ² C-bus clock input
OUT3+	5	channel 3 positive output
V _{P2}	6	power supply voltage 2 to amplifiers
OUT1-	7	channel 1 negative output
PGND1	8	power ground 1
OUT1+	9	channel 1 positive output
SVR	10	half supply voltage filter capacitor
IN1	11	channel 1 input
IN3	12	channel 3 input
SGND	13	signal ground
IN4	14	channel 4 input
IN2	15	channel 2 input
ACGND	16	AC ground
OUT2+	17	channel 2 positive output
PGND3	18	power ground 3
OUT2-	19	channel 2 negative output
V _{P1}	20	power supply voltage 1 to amplifiers
OUT4+	21	channel 4 positive output
STB	22	standby, operating or mute mode select input
OUT4-	23	channel 4 negative output
PGND4	24	power ground 4
$\overline{\text{DIAG}}$	25	diagnostic and clip detection output, active LOW
V _{DCDC}	26	power supply voltage from optional DC-to-DC converter
SW2	27	antenna switch; supplies unregulated power to car aerial motor
REG6	28	regulator 6 output; supply for bus controller
SW1	29	amplifier switch; supplies unregulated power to amplifier(s)
REG1	30	regulator 1 output; supply for audio part of radio and CD player
REG3	31	regulator 3 output; supply for signal processor part (mechanical digital) of CD player
GND	32	combined voltage regulator, power and signal ground
REG4	33	regulator 4 output; supply for mechanical part (mechanical drive) of CD player
REG5	34	regulator 5 output; supply for display part of radio and CD player
V _P	35	power supply to voltage regulators
BUCAP	36	connection for backup capacitor
REG2	37	regulator 2 output; supply voltage to microcontroller

8. Functional description

The TDF8553 is a multiple voltage regulator combined with four independent audio power amplifiers configured in bridge tied load, with diagnostic capability. All regulator output voltages except regulators 2 and 6 can be controlled via the I²C-bus.

The amplifier diagnostic functions give information about output offset, load, or short-circuit. Diagnostic functions are controlled via the I²C-bus. The TDF8553 is protected against short-circuit, over-temperature, open ground and open V_P connections. If a short-circuit occurs at the output of a single amplifier, that channel shuts down, and the other channels continue to operate normally. The channel that has a short-circuit can be switched off by the microcontroller via the appropriate enable bit of the I²C-bus to prevent any noise generated by the fault condition from being heard.

8.1 Start-up

At power on, regulators 2 and 6 will reach their final voltage when the backup capacitor voltage exceeds 5.5 V independently of the voltage on pin STB. When pin STB is LOW, the total quiescent current is low, and the I²C-bus lines are high impedance.

When pin STB is HIGH, the I²C-bus is biased on and then the TDF8553 performs a power-on reset. When bit D0 of instruction byte IB1 is set, the amplifier is activated, bit D7 of data byte DB2 (power-on reset occurred) is reset, and pin $\overline{\text{DIAG}}$ is no longer held LOW.

8.2 Start-up and shut-down timing

See [Figure 12](#).

A capacitor connected to pin SVR enables smooth start-up and shut-down, preventing the amplifier from producing audible clicks at switch-on or switch-off. The start-up and shut-down times can be extended by increasing the capacitor value.

If the amplifier is shut down using pin STB, the amplifier is muted, the regulators and switches are switched off, and the capacitor connected to pin SVR discharges. The low-current standby mode is activated 2 seconds after pin STB goes LOW.

8.3 Power-on reset and supply voltage spikes

See [Figure 13](#) and [Figure 14](#).

If the supply voltage drops too low to guarantee the integrity of the data in the I²C-bus latches, the power-on reset cycle will start. All latches will be set to a predefined state, pin $\overline{\text{DIAG}}$ will be pulled LOW to indicate that a power-on reset has occurred, and bit D7 of data byte DB2 is also set for the same reason. When D0 of instruction byte IB1 is set, the power-on flag resets, pin $\overline{\text{DIAG}}$ is released and the amplifier will then enter its start-up cycle.

8.4 Diagnostic output

Pin $\overline{\text{DIAG}}$ indicates clipping, thermal protection pre-warning of amplifier and voltage regulator sections, short-circuit protection, and low and high battery voltage. Pin $\overline{\text{DIAG}}$ is an open-drain output, is active LOW, and must be connected to an external voltage via an

external pull-up resistor. If a failure occurs, pin $\overline{\text{DIAG}}$ remains LOW during the failure and no clipping information is available. The microcontroller can read the failure information via the I²C-bus.

8.5 Amplifiers

8.5.1 Muting

A hard mute and a soft mute can both be performed via the I²C-bus. A hard mute mutes the amplifier within 0.5 ms. A soft mute mutes the amplifier within 20 ms and is less audible. A hard mute is also activated if a voltage of 8 V is applied to pin STB.

8.5.2 Temperature protection

If the average junction temperature rises to a temperature value that has been set via the I²C-bus, a thermal protection pre-warning is activated making pin $\overline{\text{DIAG}}$ LOW. If the temperature continues to rise, all four channels will be muted to reduce the output power (soft thermal clipping). The value at which the temperature mute control activates is fixed; only the temperature at which the thermal protection pre-warning signal occurs can be specified by bit D4 in instruction byte IB3. If implementing the temperature mute control does not reduce the average junction temperature, all the power stages will be switched off (muted) at the absolute maximum temperature $T_{j(\text{max})}$.

8.5.3 Offset detection

Offset detection can only be performed when there is no input signal to the amplifiers, for instance when the external digital signal processor is muted after a start-up. The output voltage of each channel is measured and compared with a reference voltage. If the output voltage of a channel is greater than the reference voltage, bit D2 of the associated data byte is set and read by the microcontroller during a read instruction. Note that the value of this bit is only meaningful when there is no input signal and the amplifier is not muted. Offset detection is always enabled.

8.5.4 Speaker protection

If one side of a speaker is connected to ground, a missing current protection is implemented to prevent damage to the speaker. A fault condition is detected in a channel when there is a mismatch between the power current in the high side and the power current in the low side; during a fault condition the channel will be switched off.

The load status of each channel can be read via the I²C-bus: short to ground (one side of the speaker connected to ground), short to V_P (one side of the speaker connected to V_P), and shorted load.

8.5.5 Line driver mode

An amplifier can be used as a line driver by switching it to low gain mode. In normal mode, the gain between single-ended input and differential output (across the load) is 26 dB. In low-gain mode the gain between single-ended input and differential output is 20 dB.

8.5.6 Input and AC ground capacitor values

The negative inputs to all four amplifier channels are combined at pin ACGND. To obtain the best performance of supply voltage ripple rejection and unwanted audible noise, the value of the capacitor connected to pin ACGND must be as close as possible to 4 times the value of the input capacitor connected to the positive input of each channel.

8.5.7 Load detection

8.5.7.1 DC-load detection

When DC-load detection is enabled, during the start-up cycle, a DC-offset is applied slowly to the amplifier outputs, and the output currents are measured. If the output current of an amplifier rises above a certain level, it is assumed that there is a load of less than 6 Ω and bit D5 is reset in the associated data byte register to indicate that a load is detected.

Because the offset is measured during the amplifier start-up cycle, detection is inaudible and can be performed every time the amplifier is switched on.

8.5.7.2 AC-load detection

AC-load detection can be used to detect that AC-coupled speakers are connected correctly during assembly. This requires at least 3 periods of a 19 kHz sine wave to be applied to the amplifier inputs. The amplifier produces a peak output voltage which also generates a peak output current through the AC-coupled speaker. The 19 kHz sine wave is also audible during the test. If the amplifier detects three current peaks that are greater than 550 mA, the AC-load detection bit is set. Three current peaks are counted to avoid false AC-load detection which can occur if the input signal is switched on and off. The peak current counter can be reset by setting bit D1 of instruction byte IB1 to logic 0. To guarantee AC-load detection, an amplifier current of more than 550 mA is required. AC-load detection will never occur with a current of less than 150 mA.

[Figure 3](#) shows which AC loads are detected at different output voltages. For example, if a load is detected at an output voltage of 2.5 V peak, the load is less than 4 Ω . If no load is detected, the output impedance is more than 14 Ω .

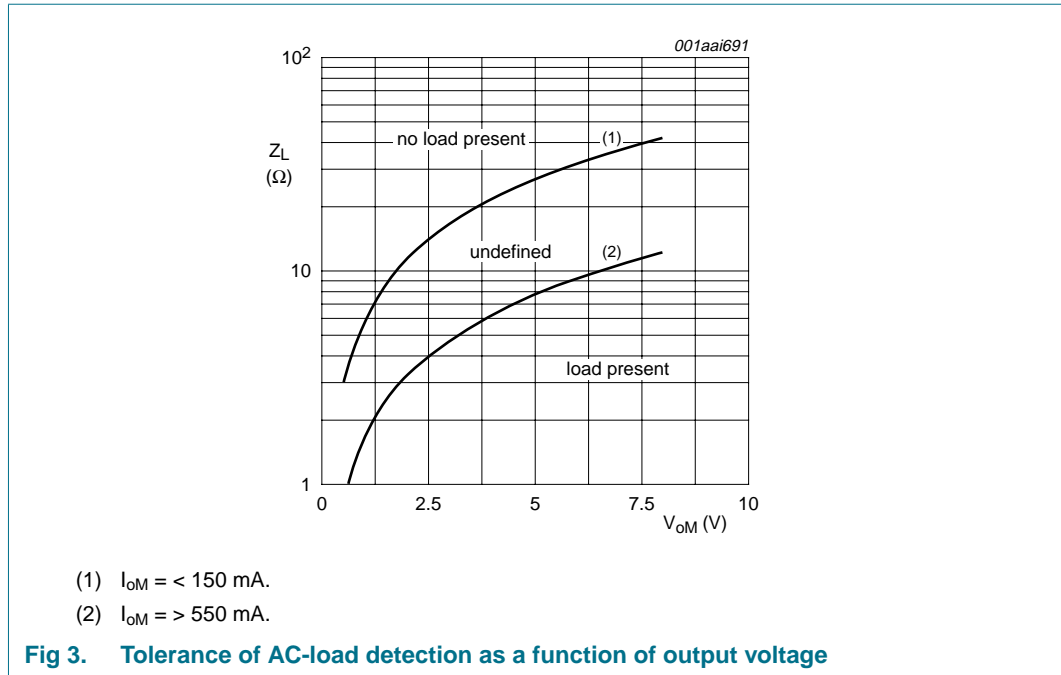

8.5.7.3 Load detection procedure

1. At start-up, enable the AC or DC-load detection by setting D1 of instruction byte IB1 to logic 1.
2. After 250 ms the DC load is detected and the mute is released. This is inaudible and can be implemented each time the IC is powered on.
3. When the amplifier start-up cycle is completed (after 1.5 s), apply an AC signal to the input, and DC-load bits D5 of each data byte should be read and stored by the microcontroller.
4. After at least 3 periods of the input signal, the load status can be checked by reading AC-detect bits D4 of each data byte.

The AC-load peak current counter can be reset by setting bit D1 of instruction byte IB1 to logic 0 and then to logic 1. Note that this will also reset the DC-load detection bits D5 in each data byte.

8.5.8 Low headroom protection

The normal DC output voltage of the amplifier is set to half the supply voltage and is related to the voltage on pin SVR. An external capacitor is connected to pin SVR to suppress power supply ripple. If the supply voltage drops (at vehicle engine start), the DC output voltage will follow slowly due to the affect of the SVR capacitor.

The headroom voltage is the voltage required for correct operation of the amplifier and is defined as the voltage difference between the level of the DC output voltage before the V_P voltage drop and the level of V_P after the voltage drop (see [Figure 4](#)).

At a certain supply voltage drop, the headroom voltage will be insufficient for correct operation of the amplifier. To prevent unwanted audible noises at the output, the headroom protection mode will be activated (see [Figure 4](#)). This protection discharges the capacitors connected to pins SVR and ACGND to increase the headroom voltage.

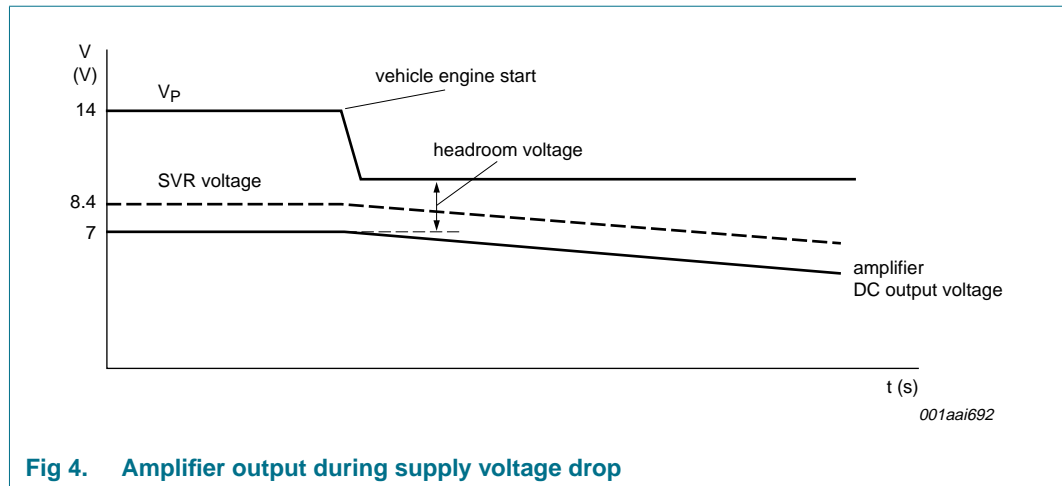

8.6 Voltage regulators

The voltage regulator section contains:

- Four switchable regulators and two standby regulators
- Two power switches with loss-of-ground and surge protection
- Second supply pin to reduce dissipation by means of an external DC-to-DC converter
- Backup functionality for regulator 2

The TDF8553 uses low dropout voltage regulators for use in low voltage applications.

All of the voltage regulators except for the standby regulators can be controlled via the I²C-bus. The voltage regulator section of this device has two power switches which are capable of delivering unregulated continuous current, and has several fail-safe protection modes. It conforms to peak transient tests and protects against continuous high voltage (24 V), short-circuits and thermal stress. Standby regulators 2 and 6 will try to maintain output for as long as possible even if a thermal shut-down or any other fault condition occurs. During overvoltage stress conditions, all outputs except regulators 2 and 6 will switch off and the device will be able to supply a minimum current for an indefinite amount of time sufficient for powering the memory of a microcontroller and bus controller functionality. Provision is made for an external reserve supply capacitor to be connected to pin BUCAP which can store enough energy to allow regulator 2 to supply a microcontroller for a period long enough for it to prepare for a loss-of-voltage.

8.6.1 Standby regulator outputs

Standby outputs (regulators 2 and 6) are used for the microcontroller and bus controller supply. These regulators will not shut down with the switched regulators and cannot be controlled by the I²C-bus. The standby regulators will not shut down during load dump transients or by high temperature protection.

8.6.2 Backup capacitor

The backup capacitor (C_{backup}) is used as a backup supply for the regulator 2 output when the battery supply voltage (V_P) cannot support the regulator 2 voltage.

8.6.3 Backup function

The backup function is implemented by a switch function, which behaves like an ideal diode between pins V_P and BUCAP; the forward voltage of this ideal diode depends on the current flowing through it. The backup function supplies regulator 2 during brief periods when no supply voltage is present on pin V_P . It requires an external capacitor to be connected to pin BUCAP and ground. When the supply voltage is present on pin V_P this capacitor will be charged to a level of $V_P - 0.3$ V. When the supply voltage is absent from pin V_P , this charge can then be used to supply regulator 2 for a brief period (t_{backup}) calculated using the formula:

$$t_{backup} = C_{backup} \times R_L \times \left(\frac{V_P - (V_{REG2} - 0.5)}{V_{REG2}} \right)$$

Example: $V_P = 14.4$ V, V_{REG2} (voltage on pin REG2) = 3.3 V, $R_L = 1$ k Ω and $C_{backup} = 100$ μ F provides a t_{backup} of 321 ms.

When an overvoltage condition occurs, the voltage on pin BUCAP is limited to approximately 24 V; see [Figure 5](#).

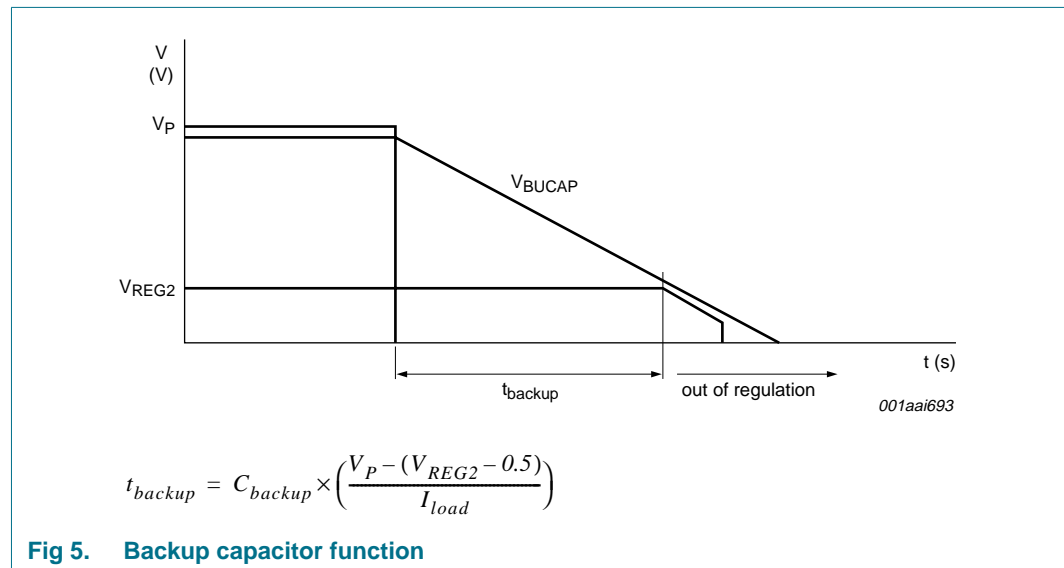

Fig 5. Backup capacitor function

8.6.4 Power switches

There are two power switches that provide an unregulated DC voltage output for amplifiers and an aerial motor respectively. The switches have internal protection for over-temperature conditions and are activated by setting bits D2 and D3 of instruction byte IB1 to logic 1.

In the ON state, the switches have a low impedance to the battery voltage. When the battery voltage is higher than 22 V, the switches are switched off. When the battery voltage is below 22 V the switches are set to their original condition.

The power switches have built-in surge protection to be able to absorb energy from switching inductive or capacitive external loads. This surge protection is implemented in such a way that in case no supply (V_P) is present the supply line will not be charged from a possible external source connected to a power switch output.

8.6.5 External DC-to-DC converter

The V_{DCDC} supply pin can be connected to an external DC-to-DC down converter ($V_O \geq 5\text{ V}$) to reduce the dissipation in regulator 3. If no external DC-to-DC converter is used, the V_{DCDC} pin must be connected to V_P .

8.6.6 Protection

All regulator and switch outputs are fully protected by foldback current limiting against load dumps and short-circuits; see [Figure 6](#). During a load dump all regulator outputs, except the output of regulators 2 and 6, will go low.

The power switches can withstand ‘loss-of-ground’. This means that if pin GND becomes disconnected, the switch is protected by automatically connecting its outputs to ground.

8.6.7 Temperature protection

If the junction temperature of a regulator becomes too high, the amplifier(s) are switched off to prevent unwanted noise signals being audible. A regulator junction temperature that is too high is indicated by pin \overline{DIAG} going LOW and is also indicated by setting bit D6 in data byte DB2.

If the junction temperature of the regulator continues to rise and reaches the maximum temperature protection level, all regulators and switches will be disabled except regulators 2 and 6.

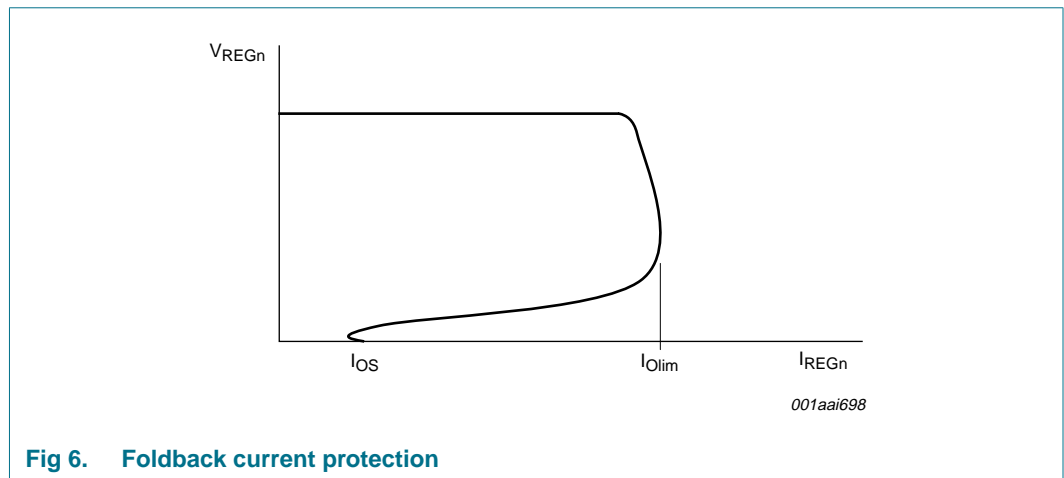

8.7 I²C-bus specification

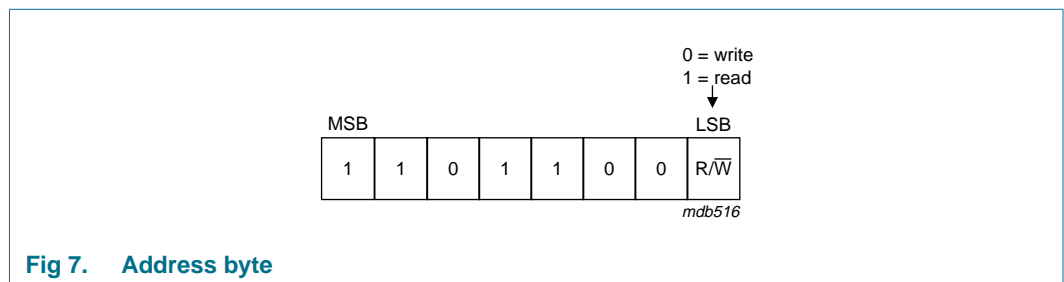

If address byte bit $R/\overline{W} = 0$, the TDF8553 expects 3 instruction bytes: IB1, IB2 and IB3; see [Table 1](#) to [Table 6](#).

After a power-on, all instruction bits are set to zero.

If address byte bit $R/\overline{W} = 1$, the TDF8553 will send 4 data bytes to the microcontroller: DB1, DB2, DB3 and DB4; see [Table 7](#) to [Table 10](#).

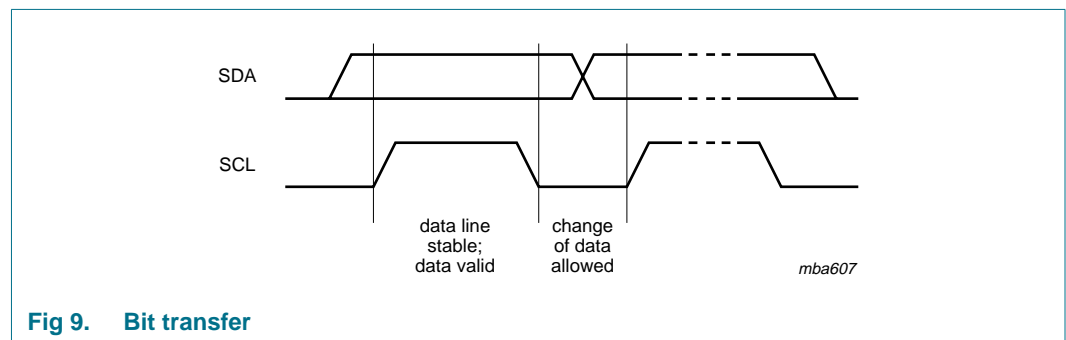
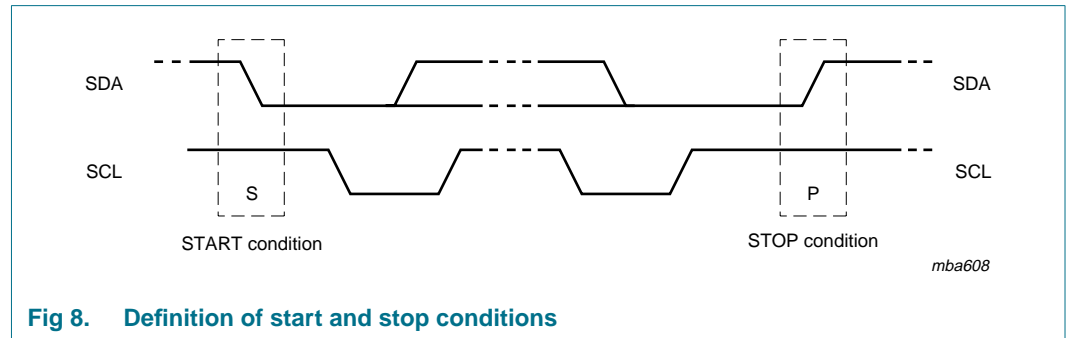

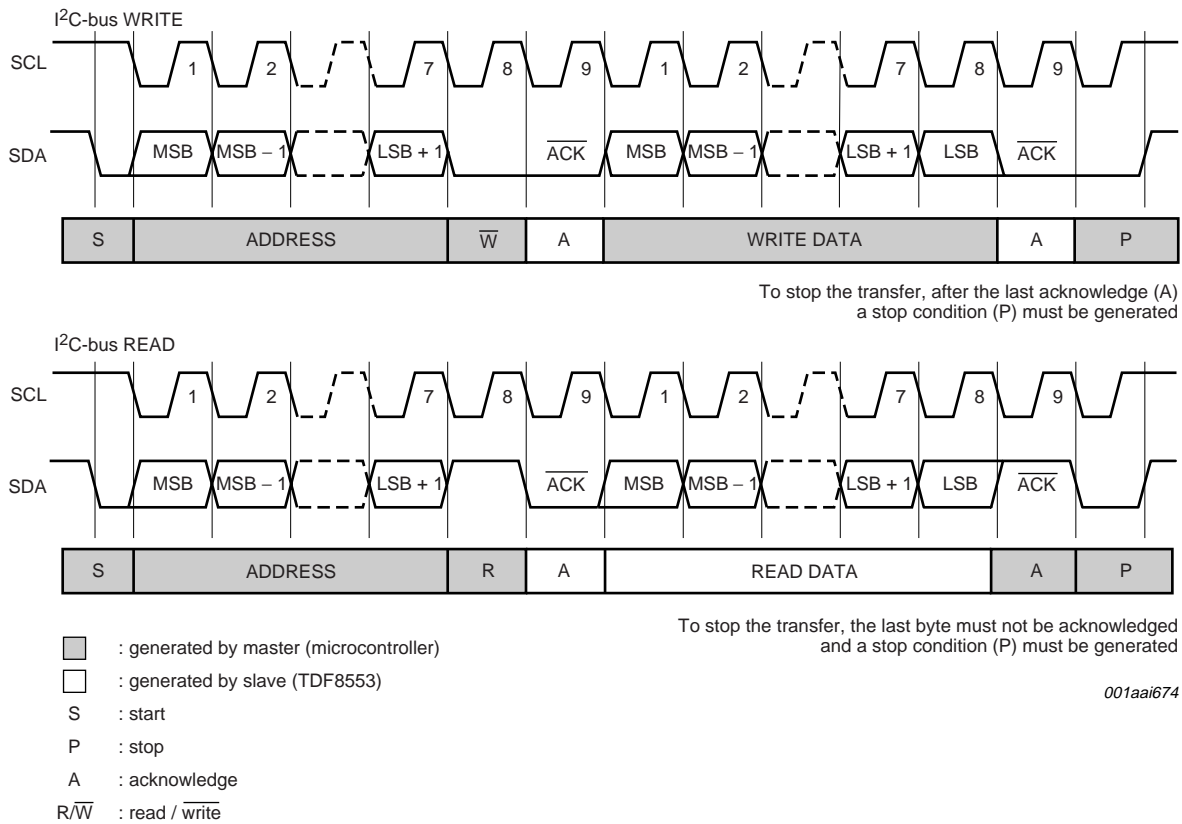

Fig 10. I²C-bus read and write modes

Table 4. Instruction byte IB1 bit description

Bit	Symbol	Description
7	D7	regulator 5 output voltage control; see Table 5
6	D6	
5	D5	
4	D4	
3	D3	SW2 control 0 = SW2 off 1 = SW2 on
2	D2	SW1 control 0 = SW1 off 1 = SW1 on
1	D1	AC-load or DC-load detection switch 0 = AC-load or DC-load detection off; resets DC-load detection bits and AC-load detection peak current counter 1 = AC-load or DC-load detection on

Table 4. Instruction byte IB1 bit description ...continued

Bit	Symbol	Description
0	D0	amplifier start enable (clear power-on reset flag D7 of DB2) 0 = amplifier off; pin $\overline{\text{DIAG}}$ remains LOW 1 = amplifier on; when power-on occurs, bit D7 of DB2 is reset and pin $\overline{\text{DIAG}}$ is released

Table 5. Regulator 5 (display) output voltage control

Bit				Output (V)
D7	D6	D5	D4	
0	0	0	0	0 (off)
0	0	0	1	6.0
0	0	1	0	7.0
0	0	1	1	8.2
0	1	0	0	9.0
0	1	0	1	9.5
0	1	1	0	10.0
0	1	1	1	10.4
1	0	0	0	12.5
1	0	0	1	$\leq V_P - 1$ (switch)
1	0	1	0	5.0
1	0	1	1	3.3

Table 6. Instruction byte IB2 bit description

Bit	Symbol	Description
7	D7	regulator 4 output voltage control; see Table 7
6	D6	
5	D5	
4	D4	regulator 3 (mechanical digital) control 0 = regulator 3 off 1 = regulator 3 on
3	D3	regulator 1 output voltage control; see Table 8
2	D2	
1	D1	soft mute all amplifier channels (mute delay 20 ms) 0 = mute off 1 = mute on
0	D0	hard mute all amplifier channels (mute delay 0.4 ms) 0 = mute off 1 = mute on

Table 7. Regulator 4 (mechanical drive) output voltage control

Bit			Output (V)
D7	D6	D5	
0	0	0	0 (off)
0	0	1	5
0	1	0	6
0	1	1	7
1	0	0	8.6
1	0	1	8.0

Table 8. Regulator 1 (audio) output voltage control

Bit		Output (V)
D3	D2	
0	0	0 (off)
0	1	8.3
1	0	8.6
1	1	5.0

Table 9. Instruction byte IB3 bit description

Bit	Symbol	Description
7	D7	clip detection level 0 = 4 % detection level 1 = 1 % detection level
6	D6	amplifier channels 1 and 2 gain select 0 = 26 dB gain (normal mode) 1 = 20 dB gain (line-driver mode)
5	D5	amplifier channels 3 and 4 gain select 0 = 26 dB gain (normal mode) 1 = 20 dB gain (line-driver mode)
4	D4	amplifier thermal protection pre-warning 0 = warning at 145 °C 1 = warning at 122 °C
3	D3	disable channel 1 0 = enable channel 1 1 = disable channel 1
2	D2	disable channel 2 0 = enable channel 2 1 = disable channel 2
1	D1	disable channel 3 0 = enable channel 3 1 = disable channel 3

Table 9. Instruction byte IB3 bit description ...continued

Bit	Symbol	Description
0	D0	disable channel 4 0 = enable channel 4 1 = disable channel 4

Table 10. Instruction byte DB1 bit description

Bit	Symbol	Description
7	D7	amplifier thermal protection pre-warning 0 = no warning 1 = junction temperature above pre-warning level
6	D6	amplifier maximum thermal protection 0 = junction temperature below 175 °C 1 = junction temperature above 175 °C
5	D5	channel 4 DC load detection 0 = DC load detected 1 = no DC load detected
4	D4	channel 4 AC load detection 0 = no AC load detected 1 = AC load detected
3	D3	channel 4 load short-circuit 0 = normal load 1 = short-circuit load
2	D2	channel 4 output offset 0 = no output offset 1 = output offset
1	D1	channel 4 V_P short-circuit 0 = no short-circuit to V_P 1 = short-circuit to V_P
0	D0	channel 4 short-circuit to ground 0 = no short-circuit to ground 1 = short-circuit to ground

Table 11. Data byte DB2 bit description

Bit	Symbol	Description
7	D7	Power-on reset occurred or amplifier status 0 = amplifier on 1 = POR has occurred; amplifier off
6	D6	regulator thermal protection pre-warning 0 = no warning 1 = regulator temperature too high; amplifier off

Table 11. Data byte DB2 bit description ...continued

Bit	Symbol	Description
5	D5	channel 3 DC load detection 0 = DC load detected 1 = no DC load detected
4	D4	channel 3 AC load detection 0 = no AC load detected 1 = AC load detected
3	D3	channel 3 load short-circuit 0 = normal load 1 = short-circuit load
2	D2	channel 3 output offset 0 = no output offset 1 = output offset
1	D1	channel 3 V_P short-circuit 0 = no short-circuit to V_P 1 = short-circuit to V_P
0	D0	channel 3 short-circuit to ground 0 = no short-circuit to ground 1 = short-circuit to ground

Table 12. Data byte DB3 bit description

Bit	Symbol	Description
7	D7	-
6	D6	-
5	D5	channel 2 DC load detection 0 = DC load detected 1 = no DC load detected
4	D4	channel 2 AC load detection 0 = no AC load detected 1 = AC load detected
3	D3	channel 2 load short-circuit 0 = normal load 1 = short-circuit load
2	D2	channel 2 output offset 0 = no output offset 1 = output offset
1	D1	channel 2 V_P short-circuit 0 = no short-circuit to V_P 1 = short-circuit to V_P
0	D0	channel 2 short-circuit to ground 0 = no short-circuit to ground 1 = short-circuit to ground

Table 13. Data byte DB4 bit description

Bit	Symbol	Description
7	D7	-
6	D6	-
5	D5	channel 1 DC load detection 0 = DC load detected 1 = no DC load detected
4	D4	channel 1 AC load detected 0 = no AC load detected 1 = AC load detected
3	D3	channel 1 load short-circuit 0 = normal load 1 = short-circuit load
2	D2	channel 1 output offset 0 = no output offset 1 = output offset
1	D1	channel 1 short-circuit to V_P 0 = no short-circuit to V_P 1 = short-circuit to V_P
0	D0	channel 1 short-circuit to ground 0 = no short-circuit to ground 1 = short-circuit to ground

9. Limiting values

Table 14. Limiting values

In accordance with the Absolute Maximum Rating System (IEC 60134).

Symbol	Parameter	Conditions	Min	Max	Unit
V_P	supply voltage	operating	-	18	V
		not operating	-1	+50	V
		jump starts for $t \leq 10$ minutes	-	30	V
		load dump protection for $t \leq 50$ ms and $t_r \geq 2.5$ ms	0	50	V
V_{SDA}	voltage on pin SDA	operating	0	7	V
V_{SCL}	voltage on pin SCL	operating	0	7	V
V_I	input voltage	pins INn, SVR, ACGND, DIAG, operating	0	13	V
V_{STB}	voltage on pin STB	operating	0	24	V
I_{OSM}	non-repetitive peak output current		-	10	A
I_{ORM}	repetitive peak output current		-	6	A
$V_{P(sc)}$	short-circuit supply voltage	across output pin loads and to ground or supply (AC and DC)	-	18	V

Table 14. Limiting values ...continued

In accordance with the Absolute Maximum Rating System (IEC 60134).

Symbol	Parameter	Conditions	Min	Max	Unit
$V_{P(r)}$	reverse supply voltage	voltage regulator only	-	-18	V
P_{tot}	total power dissipation	$T_{case} = 70\text{ °C}$	-	80	W
T_j	junction temperature		-	150	°C
T_{stg}	storage temperature		-55	+150	°C
T_{amb}	ambient temperature		-40	+85	°C
V_{esd}	electrostatic discharge voltage		[1]	2000	V
			[2]	200	V

[1] Human body model: $R_s = 1.5\text{ k}\Omega$; $C = 100\text{ pF}$; all pins have passed all tests to 2500 V to guarantee 2000 V, according to class II.

[2] Machine model: $R_s = 10\ \Omega$; $C = 200\text{ pF}$; $L = 0.75\text{ mH}$; all pins have passed all tests to 250 V to guarantee 200 V, according to class II.

10. Thermal characteristics

Table 15. Thermal characteristics

Symbol	Parameter	Conditions	Typ	Unit
$R_{th(j-a)}$	thermal resistance from junction to ambient	in free air	40	K/W
$R_{th(j-c)}$	thermal resistance from junction to case	see Figure 11	0.75	K/W

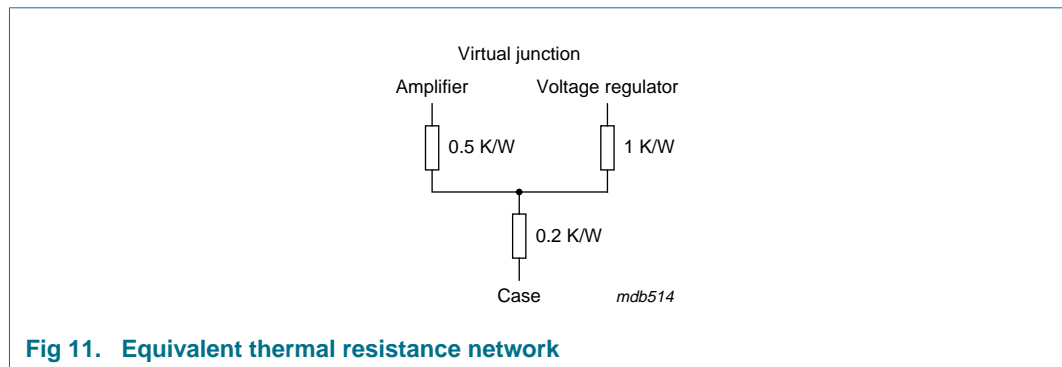

Fig 11. Equivalent thermal resistance network

10.1 Quality specification

In accordance with “General Quality Specification for Integrated Circuits SNW-FQ-611D”.

11. Characteristics

Table 16. Characteristics

$T_{amb} = 25\text{ }^{\circ}\text{C}$; V_{DCDC} ; $V_P = 14.4\text{ V}$; $R_L = 4\text{ }\Omega$; measured in the test circuit [Figure 26](#); unless otherwise specified.

Symbol	Parameter	Conditions	Min	Typ	Max	Unit
Amplifier section						
Supply voltage behavior						
$V_{P(oper)}$	operating supply voltage	$R_L = 4\text{ }\Omega$	8	14.4	18	V
		$R_L = 2\text{ }\Omega$	8	14.4	16	V
$I_{q(tot)}$	total quiescent current	no load	-	280	400	mA
I_{stb}	standby current		-	10	50	μA
V_O	output voltage	DC	-	7.2	-	V
$V_{P(low)(mute)}$	low supply voltage mute		6.5	7	8	V
V_{hr}	headroom voltage	when headroom protection is activated; see Figure 4	-	1.4	-	V
V_{POR}	power-on reset voltage	see Figure 13	-	5.5	-	V
$V_{O(offset)}$	output offset voltage	mute mode and power on	-100	0	+100	mV
Mode select (pin STB)						
V_{STB}	voltage on pin STB	standby mode	-	-	1.3	V
		operating mode	2.5	-	5.5	V
		mute mode	8	-	V_P	V
I_I	input current	$V_{STB} = 5\text{ V}$	-	4	25	μA
Start-up, shut-down and mute timing						
t_{wake}	wake-up time	from standby before first I ² C-bus transmission is recognized; via pin STB; see Figure 12	-	300	500	μs
$t_{d(mute_off)}$	mute off delay time	via I ² C-bus (IB1 bit D0); $C_{SVR} = 22\text{ }\mu\text{F}$; see Figure 12	-	250	-	ms
$t_{d(mute-on)}$	delay time from mute to on	soft mute; via I ² C-bus (IB2 bit D1 = 1 to 0)	10	25	40	ms
		hard mute; via I ² C-bus (IB2 bit D0 = 1 to 0)	10	25	40	ms
		via pin STB; $V_{STB} = 8\text{ V to }4\text{ V}$	10	25	40	ms
$t_{d(on-mute)}$	delay time from on to mute	soft mute; via I ² C-bus (IB2 bit D1 = 0 to 1)	10	25	40	ms
		hard mute; via I ² C-bus (IB2 bit D0 = 0 to 1)	-	0.4	1	ms
		via pin STB; $V_{STB} = 4\text{ V to }8\text{ V}$	-	0.4	1	ms
I²C-bus interface						
V_{IL}	LOW-level input voltage	on pins SCL and SDA	-	-	1.5	V
V_{IH}	HIGH-level input voltage	on pins SCL and SDA	2.3	-	5.5	V
V_{OL}	LOW-level output voltage	on pin SDA; $I_{load} = 3\text{ mA}$	-	-	0.4	V
f_{SCL}	SCL clock frequency		-	-	400	kHz

Table 16. Characteristics ...continued

$T_{amb} = 25\text{ }^{\circ}\text{C}$; V_{DCDC} ; $V_P = 14.4\text{ V}$; $R_L = 4\text{ }\Omega$; measured in the test circuit [Figure 26](#); unless otherwise specified.

Symbol	Parameter	Conditions	Min	Typ	Max	Unit
Amplifier diagnostics						
$V_{OL(DIAG_N)}$	LOW-level output voltage on pin \overline{DIAG}	fault condition (pin LOW); $I_{DIAG_N} = 200\text{ }\mu\text{A}$	-	-	0.8	V
$V_{O(offset)}$	output offset voltage		± 1.5	± 2	± 2.5	V
THD_{clip}	total harmonic distortion clip detection level	IB3 bit D7 = 0	-	4	-	%
		IB3 bit D7 = 1	-	1	-	%
$T_{j(AV)(pwarn)}$	pre-warning average junction temperature	IB3 bit D4 = 0	135	145	155	$^{\circ}\text{C}$
		IB3 bit D4 = 1	112	122	132	$^{\circ}\text{C}$
$T_{j(AV)(mute)}$	mute average junction temperature	$V_{IN} = 0.05\text{ V}$; -3 dB muting	150	160	170	$^{\circ}\text{C}$
$T_{j(AV)(off)}$	average junction temperature for off	all outputs switched off	165	175	185	$^{\circ}\text{C}$
Z_L	load impedance	DC load detected	-	-	6	Ω
		no DC load detected	500	-	-	Ω
$I_{det(load)}$	load detection current	AC load detected	550	-	-	mA
		no AC load detected	-	-	150	mA
Amplifier						
P_o	output power	$R_L = 4\text{ }\Omega$; $V_P = 14.4\text{ V}$; THD = 0.5 %	20	21	-	W
		$R_L = 4\text{ }\Omega$; $V_P = 14.4\text{ V}$; THD = 10 %	27	28	-	W
		$R_L = 2\text{ }\Omega$; $V_P = 14.4\text{ V}$; THD = 0.5 %	37	41	-	W
		$R_L = 2\text{ }\Omega$; $V_P = 14.4\text{ V}$; THD = 10 %	51	55	-	W
$P_{o(max)}$	maximum output power	$R_L = 4\text{ }\Omega$; $V_P = 14.4\text{ V}$; $V_{IN} = 2\text{ V RMS square wave}$	44	46	-	W
		$R_L = 4\text{ }\Omega$; $V_P = 15.2\text{ V}$; $V_{IN} = 2\text{ V RMS square wave}$	49	52	-	W
		$R_L = 2\text{ }\Omega$; $V_P = 14.4\text{ V}$; $V_{IN} = 2\text{ V RMS square wave}$	83	87	-	W
THD	total harmonic distortion	$P_o = 1\text{ W to }12\text{ W}$; $f = 1\text{ kHz}$; $R_L = 4\text{ }\Omega$	-	0.01	0.1	%
		$P_o = 1\text{ W to }12\text{ W}$; $f = 10\text{ kHz}$	-	0.2	0.5	%
		$P_o = 4\text{ W}$; $f = 1\text{ kHz}$	-	0.01	0.03	%
		line driver mode; $V_o = 2\text{ V (RMS)}$; $f = 1\text{ kHz}$; $R_L = 600\text{ }\Omega$	-	0.01	0.03	%
		$f = 1\text{ Hz to }10\text{ kHz}$; $R_S = 600\text{ }\Omega$	50	60	-	dB
α_{cs}	channel separation	$P_o = 4\text{ W}$; $f = 1\text{ kHz}$	-	80	-	dB
		$f = 100\text{ Hz to }10\text{ kHz}$; $R_S = 600\text{ }\Omega$	55	70	-	dB
SVRR	supply voltage rejection ratio	$f = 100\text{ Hz to }10\text{ kHz}$; $R_S = 600\text{ }\Omega$	55	70	-	dB
CMRR	common mode rejection ratio	amplifier mode; $V_{cm} = 0.3\text{ V (p-p)}$; $f = 1\text{ kHz to }3\text{ kHz}$; $R_S = 0\text{ }\Omega$	40	70	-	dB

Table 16. Characteristics ...continued

$T_{amb} = 25\text{ }^{\circ}\text{C}$; V_{DCDC} ; $V_P = 14.4\text{ V}$; $R_L = 4\text{ }\Omega$; measured in the test circuit [Figure 26](#); unless otherwise specified.

Symbol	Parameter	Conditions	Min	Typ	Max	Unit
$V_{cm(max)(rms)}$	maximum common mode voltage (rms value)	$f = 1\text{ kHz}$	-	-	0.6	V
$V_{n(o)}$	output noise voltage	filter 20 Hz to 22 kHz; $R_S = 600\text{ }\Omega$				
		line driver mode	-	25	35	μV
		amplifier mode	-	50	70	μV
$G_{v(amp)}$	voltage gain amplifier mode	single-ended in to differential out	25	26	27	dB
$G_{v(ld)}$	voltage gain line driver mode	single-ended in to differential out	19	20	21	dB
Z_i	input impedance	$C_{in} = 220\text{ nF}$	55	70	-	k Ω
α_{mute}	mute attenuation	$V_{O(on)}/V_{O(mute)}$	80	90	-	dB
$V_{O(mute)}$	mute output voltage	$V_i = 1\text{ V (RMS)}$	-	70	-	μV
B_p	power bandwidth	-1 dB; THD = 1 %	-	20	-	kHz

Voltage regulator section

V_P	supply voltage	regulator 1, 3, 4 and 5 on; switches 1 and 2 on	10.0	14.4	18	V
		standby regulator 2 in regulation	5.0	-	50	V
		standby regulator 6 in regulation	6.0	-	50	V
$V_{th(dis)}$	disable threshold voltage	regulator 1, 3, 4 and 5 on; switches 1 and 2 on	18.1	22	-	V
V_{DCDC}	DC-to-DC converter voltage		4.75	5.0	V_P	V
$I_{q(tot)}$	total quiescent current	standby mode	[1]	-	180	250 μA

Regulator 1 (pin REG1) audio supply; $I_O = 5\text{ mA}$ unless otherwise specified

$V_{O(reg)}$	regulator output voltage	$0.5\text{ mA} \leq I_O \leq 400\text{ mA}$; $10\text{ V} < V_P < 18\text{ V}$				
		$IB2[D3:D2] = 01$	7.9	8.3	8.7	V
		$IB2[D3:D2] = 10$	8.1	8.6	9.1	V
		$IB2[D3:D2] = 11$	4.75	5.0	5.25	V
SVRR	supply voltage rejection ratio	$f_{ripple} = 120\text{ Hz}$; $V_{ripple} = 2\text{ V (p-p)}$	50	60	-	dB
V_{do}	dropout voltage	$V_P = 7\text{ V}$; $IB2[D3:D2] = 01$ [3]				
		$I_O = 300\text{ mA}$	-	0.5	0.8	V
		$I_O = 400\text{ mA}$	-	0.7	1.2	V
I_O	output current	$V_O \geq 4\text{ V}$	[4]	400	700	- mA
I_{OS}	output short-circuit current	$R_L \leq 0.5\text{ }\Omega$	[5]	100	200	- mA

Line regulation

ΔV_O	output voltage variation	$10\text{ V} \leq V_P \leq 18\text{ V}$	-	-	50	mV
--------------	--------------------------	---	---	---	----	----

Load regulation

ΔV_O	output voltage variation	$5\text{ mA} \leq I_O \leq 400\text{ mA}$	-	-	100	mV
--------------	--------------------------	---	---	---	-----	----

Table 16. Characteristics ...continued

$T_{amb} = 25\text{ }^{\circ}\text{C}$; V_{DCDC} ; $V_P = 14.4\text{ V}$; $R_L = 4\text{ }\Omega$; measured in the test circuit [Figure 26](#); unless otherwise specified.

Symbol	Parameter	Conditions	Min	Typ	Max	Unit
Regulator 2 (pin REG2) microprocessor supply; $I_O = 5\text{ mA}$ unless otherwise specified						
$V_{O(\text{reg})}$	regulator output voltage	$0.5\text{ mA} \leq I_O \leq 350\text{ mA}$; $10\text{ V} \leq V_P \leq 18\text{ V}$	3.1	3.3	3.5	V
SVRR	supply voltage rejection ratio	$f_{\text{ripple}} = 120\text{ Hz}$; $V_{\text{ripple}} = 2\text{ V (p-p)}$	40	50	-	dB
V_{do}	dropout voltage	$V_{\text{BUCAP}} = 4.75\text{ V}$ $I_O = 350\text{ mA}$	[6][8] -	1.45	2.0	V
I_O	output current	$V_O \geq 2.8\text{ V}$	[4] 350	1000	-	mA
I_{OS}	output short-circuit current	$R_L \leq 0.5\text{ }\Omega$	[5] 160	300	-	mA
Line regulation						
ΔV_O	output voltage variation	$10\text{ V} \leq V_P \leq 18\text{ V}$	-	3	50	mV
Load regulation						
ΔV_O	output voltage variation	$0.5\text{ mA} \leq I_O \leq 350\text{ mA}$	-	-	100	mV
Regulator 3 (pin REG3) mechanical digital supply; $I_O = 5\text{ mA}$ unless otherwise specified						
$V_{O(\text{reg})}$	regulator output voltage	$10\text{ V} \leq V_P \leq 18\text{ V}$; $0.5\text{ mA} \leq I_O \leq 500\text{ mA}$; $5\text{ V} \leq V_{\text{DCDC}} \leq 18\text{ V}$	3.1	3.3	3.5	V
SVRR	supply voltage rejection ratio	$f_{\text{ripple}} = 120\text{ Hz}$; $V_{\text{ripple}} = 2\text{ V (p-p)}$	50	65	-	dB
V_{do}	dropout voltage	$V_{\text{DCDC}} = 4.75\text{ V}$; $I_O = 500\text{ mA}$	[2][8] -	1.45	2.0	V
I_O	output current	$V_O \geq 2.8\text{ V}$	[4] 500	900	-	mA
I_{OS}	output short-circuit current	$R_L \leq 0.5\text{ }\Omega$	[5] 180	350	-	mA
Line regulation						
ΔV_O	output voltage variation	$5\text{ V} \leq V_{\text{DCDC}} \leq 18\text{ V}$	-	3	50	mV
Load regulation						
ΔV_O	output voltage variation	$0.5\text{ mA} \leq I_O \leq 500\text{ mA}$	-	-	100	mV
Regulator 4 (pin REG4) mechanical drive supply; $I_O = 5\text{ mA}$ unless otherwise specified						
$V_{O(\text{reg})}$	regulator output voltage	$10\text{ V} \leq V_P \leq 18\text{ V}$; $0.5\text{ mA} \leq I_O \leq 800\text{ mA}$				
		$IB2[\text{D7:D5}] = 001$	4.75	5.0	5.25	V
		$IB2[\text{D7:D5}] = 010$	5.7	6.0	6.3	V
		$IB2[\text{D7:D5}] = 011$	6.6	7.0	7.4	V
		$IB2[\text{D7:D5}] = 100$	8.1	8.6	9.1	V
		$IB2[\text{D7:D5}] = 101$	7.6	8.0	8.4	V
SVRR	supply voltage rejection ratio	$f_{\text{ripple}} = 120\text{ Hz}$; $V_{\text{ripple}} = 2\text{ V (p-p)}$	50	65	-	dB
V_{do}	dropout voltage	$V_P = 7\text{ V}$; $IB2[\text{D7:D5}] = 011$ $I_O = 500\text{ mA}$ $I_O = 800\text{ mA}$	[3] - -	0.5 0.7	0.8 1.2	V V
I_{OM}	peak output current	$T \leq 3\text{ s}$; $V_O = 4\text{ V}$	1	1.5	-	A
I_O	output current	$V_O \geq 4\text{ V}$; $T \leq 100\text{ ms}$; $V_P \geq 11.5\text{ V}$	[4] 1.5	2	-	A

Table 16. Characteristics ...continued

$T_{amb} = 25\text{ }^{\circ}\text{C}$; V_{DCDC} ; $V_P = 14.4\text{ V}$; $R_L = 4\text{ }\Omega$; measured in the test circuit [Figure 26](#); unless otherwise specified.

Symbol	Parameter	Conditions	Min	Typ	Max	Unit
I_{OS}	output short-circuit current	$R_L \leq 0.5\text{ }\Omega$	[5] 240	400	-	mA
<i>Line regulation</i>						
ΔV_O	output voltage variation	$10\text{ V} \leq V_P \leq 18\text{ V}$	-	3	50	mV
<i>Load regulation</i>						
ΔV_O	output voltage variation	$0.5\text{ mA} \leq I_O \leq 800\text{ mA}$	-	-	100	mV
Regulator 5 (pin REG5) display supply; $I_O = 5\text{ mA}$ unless otherwise specified						
$V_{O(\text{reg})}$	regulator output voltage	$0.5\text{ mA} \leq I_O \leq 400\text{ mA}$				
		$10\text{ V} \leq V_P \leq 18\text{ V}$; $IB1[D7:D4] = 0001$	5.7	6.0	6.3	V
		$10\text{ V} \leq V_P \leq 18\text{ V}$; $IB1[D7:D4] = 0010$	6.65	7.0	7.37	V
		$10\text{ V} \leq V_P \leq 18\text{ V}$; $IB1[D7:D4] = 0011$	7.8	8.2	8.6	V
		$10.5\text{ V} \leq V_P \leq 18\text{ V}$; $IB1[D7:D4] = 0100$	8.55	9.0	9.45	V
		$11\text{ V} \leq V_P \leq 18\text{ V}$; $IB1[D7:D4] = 0101$	9.0	9.5	10.0	V
		$11.5\text{ V} \leq V_P \leq 18\text{ V}$; $IB1[D7:D4] = 0110$	9.5	10.0	10.5	V
		$13\text{ V} \leq V_P \leq 18\text{ V}$; $IB1[D7:D4] = 0111$	9.9	10.4	10.9	V
		$14.2\text{ V} \leq V_P \leq 18\text{ V}$; $IB1[D7:D4] = 1000$	11.8	12.5	13.2	V
		$12.5\text{ V} \leq V_P \leq 18\text{ V}$; $IB1[D7:D4] = 1001$	$V_P - 1$	$V_P - 0.5$	-	V
		$10\text{ V} \leq V_P \leq 18\text{ V}$; $IB1[D7:D4] = 1010$	4.75	5.0	5.25	V
		$10\text{ V} \leq V_P \leq 18\text{ V}$; $IB1[D7:D4] = 1011$	3.1	3.3	3.5	V
SVRR	supply voltage rejection ratio	$f_{\text{ripple}} = 120\text{ Hz}$; $V_{\text{ripple}} = 2\text{ V (p-p)}$	50	60	-	dB
V_{do}	dropout voltage	$V_P = 7\text{ V}$; $IB1[D7:D4] = 0010$	[3]			
		$I_O = 300\text{ mA}$	-	0.5	0.8	V
		$I_O = 400\text{ mA}$	-	0.7	1.2	V
I_O	output current	$V_O \geq 2.8\text{ V}$	[4] 400	900	-	mA
I_{OS}	output short-circuit current	$R_L \leq 0.5\text{ }\Omega$	[5] 150	300	-	mA
<i>Line regulation</i>						
ΔV_O	output voltage variation	$10\text{ V} \leq V_P \leq 18\text{ V}$	-	3	50	mV
<i>Load regulation</i>						
ΔV_O	output voltage variation	$0.5\text{ mA} \leq I_O \leq 400\text{ mA}$	-	-	100	mV
Regulator 6 (pin REG6) bus control supply; $I_O = 5\text{ mA}$ unless otherwise specified						
$V_{O(\text{reg})}$	regulator output voltage	$0.5\text{ mA} \leq I_O \leq 100\text{ mA}$; $10\text{ V} \leq V_P \leq 18\text{ V}$	4.75	5.0	5.25	V

Table 16. Characteristics ...continued

$T_{amb} = 25\text{ °C}$; V_{DCDC} ; $V_P = 14.4\text{ V}$; $R_L = 4\text{ }\Omega$; measured in the test circuit [Figure 26](#); unless otherwise specified.

Symbol	Parameter	Conditions	Min	Typ	Max	Unit
SVRR	supply voltage rejection ratio	$f_{ripple} = 120\text{ Hz}$; $V_{ripple} = 2\text{ V (p-p)}$	40	50	-	dB
V_{do}	dropout voltage	$V_P = 4.75\text{ V}$; $I_O = 100\text{ mA}$	[3] -	0.4	0.8	V
I_O	output current	$V_O > 4.0\text{ V}$	[4] 150	350	-	mA
I_{OS}	output short-circuit current	$R_L < 0.5\text{ }\Omega$	[5] 50	125	-	mA
<i>Line regulation</i>						
ΔV_O	output voltage variation	$10\text{ V} \leq V_P \leq 18\text{ V}$	-	3	50	mV
<i>Load regulation</i>						
ΔV_O	output voltage variation	$0.5\text{ mA} \leq I_O \leq 100\text{ mA}$	-	-	100	mV
<i>Power switch 1 (pin SW1) antenna</i>						
V_{do}	dropout voltage	$I_O = 300\text{ mA}$	-	0.6	0.8	V
		$I_O = 400\text{ mA}$	-	0.6	1.1	V
I_O	output current	$V_O \geq 8.5\text{ V}$	[4] 0.5	1	-	A
I_{OS}	output short-circuit current	$R_L \leq 0.5\text{ }\Omega$	[5] -	250	-	mA
I_L	leakage current	$V_O = 18\text{ V}$; $V_P = 0\text{ V}$	[7] -	25	250	μA
<i>Power switch 2 (pin SW2) amplifier</i>						
V_{do}	dropout voltage	$I_O = 300\text{ mA}$	-	0.6	0.8	V
		$I_O = 400\text{ mA}$	-	0.6	1.1	V
I_O	output current	$V_O \geq 8.5\text{ V}$	[4] 0.5	1	-	A
I_{OS}	output short-circuit current	$R_L \leq 0.5\text{ }\Omega$	[5] -	250	-	mA
I_L	leakage current	$V_O = 18\text{ V}$; $V_P = 0\text{ V}$	[7] -	25	250	μA
<i>Backup switch</i>						
I_{bu}	backup current (DC)	$V_{BUCAP} \geq 6\text{ V}$	0.4	1.5	-	A
V_{CL}	clamping voltage	$V_P = 30\text{ V}$; $I_{O(reg2)} = 100\text{ mA}$	-	24	28	V
V_{do}	dropout voltage	$I_O = 500\text{ mA}$; $(V_P - V_{BUCAP})$	-	0.8	1.2	V

- [1] The quiescent current is measured in standby mode when $R_L = \infty$.
- [2] The dropout voltage of regulator 3 is the voltage difference between V_{DCDC} and $V_{O(reg)}$.
- [3] The dropout voltage of a regulator is the voltage difference between V_P and $V_{O(reg)}$.
- [4] At current limit, $V_{O(reg)}$ is held constant; see [Figure 6](#).
- [5] The foldback current protection limits the dissipation power at short-circuit; see [Figure 6](#).
- [6] The dropout voltage of regulator 2 is the voltage difference between V_{BUCAP} and $V_{O(reg)}$.
- [7] Unbiased switch-supply I_L is measured in supply line V_P .
- [8] Regulator output still in regulation at applied test voltage, therefore the actual dropout voltage can not be measured.

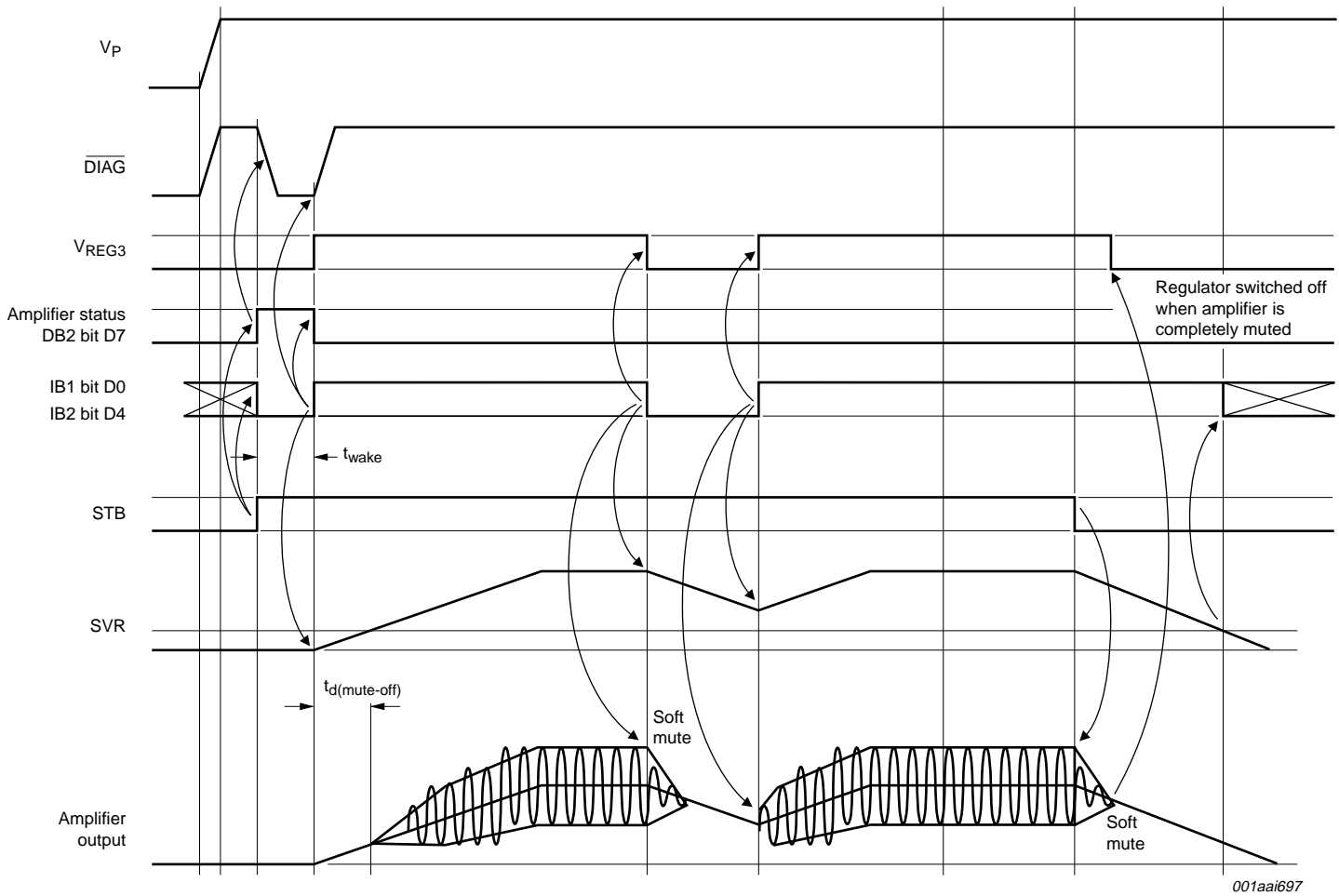

Fig 12. Start-up and shut-down timing

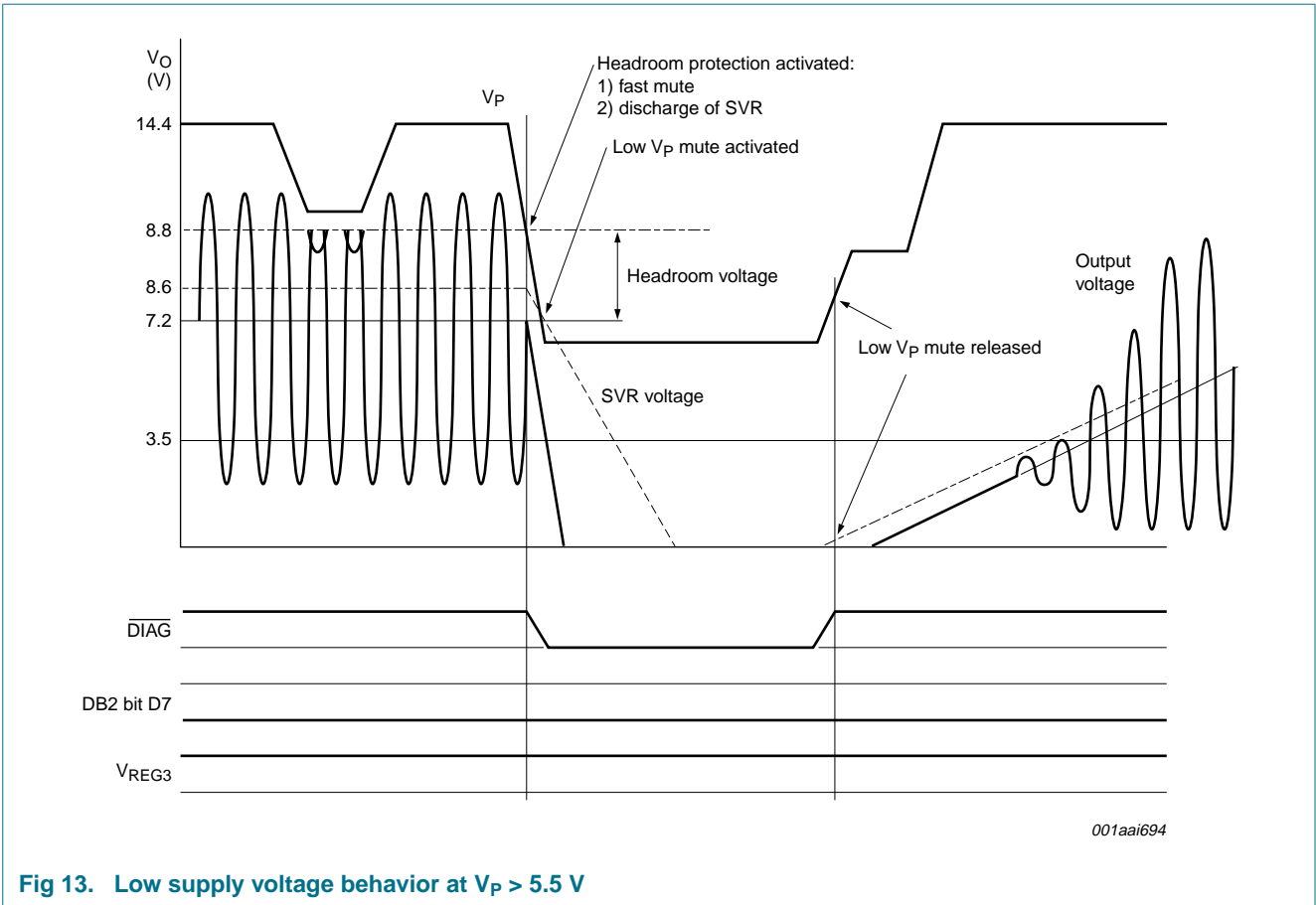

Fig 13. Low supply voltage behavior at $V_P > 5.5$ V

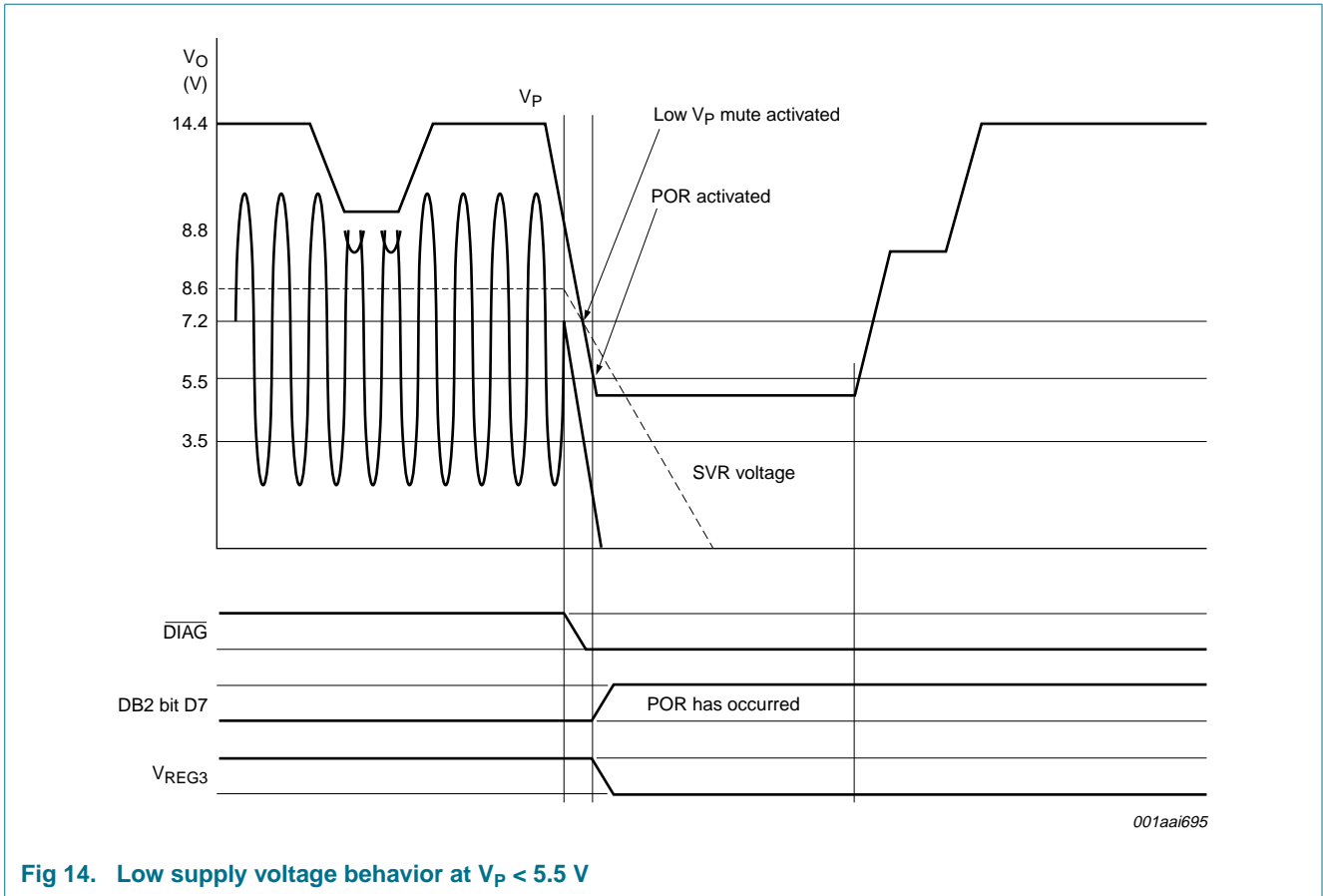
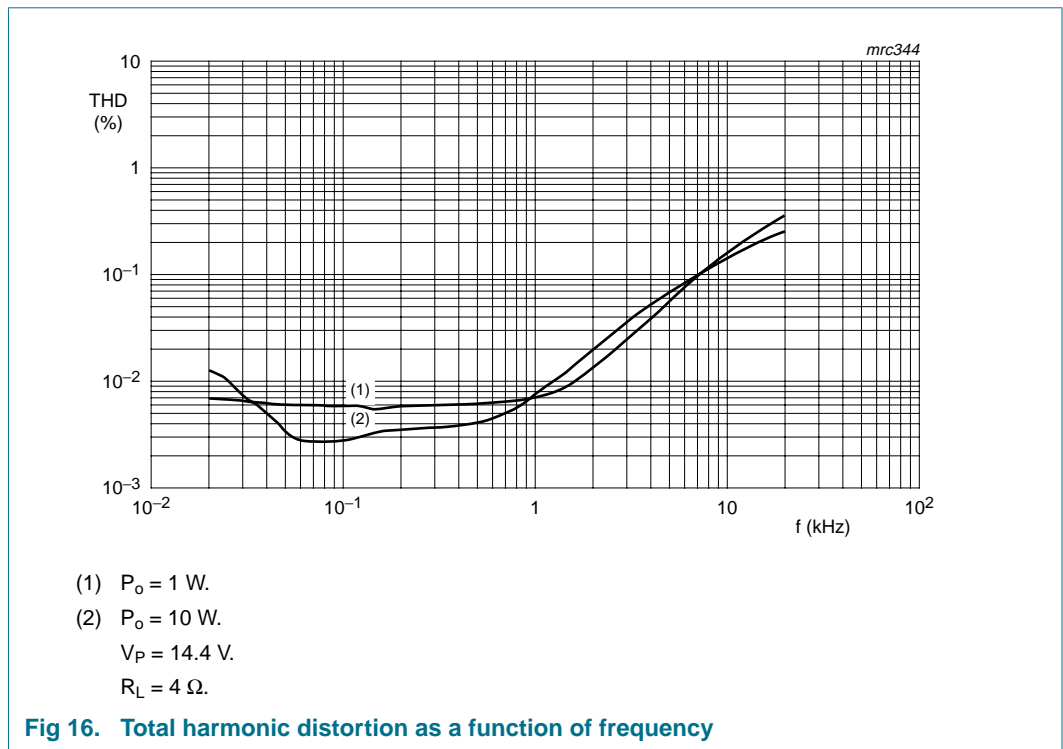
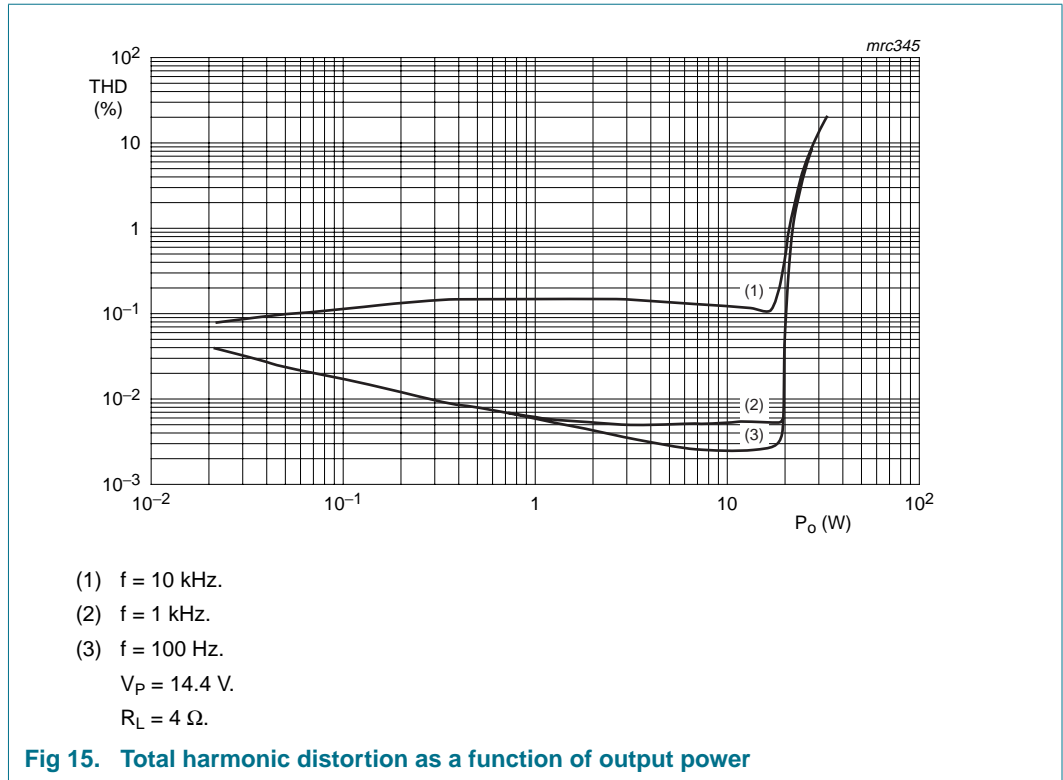
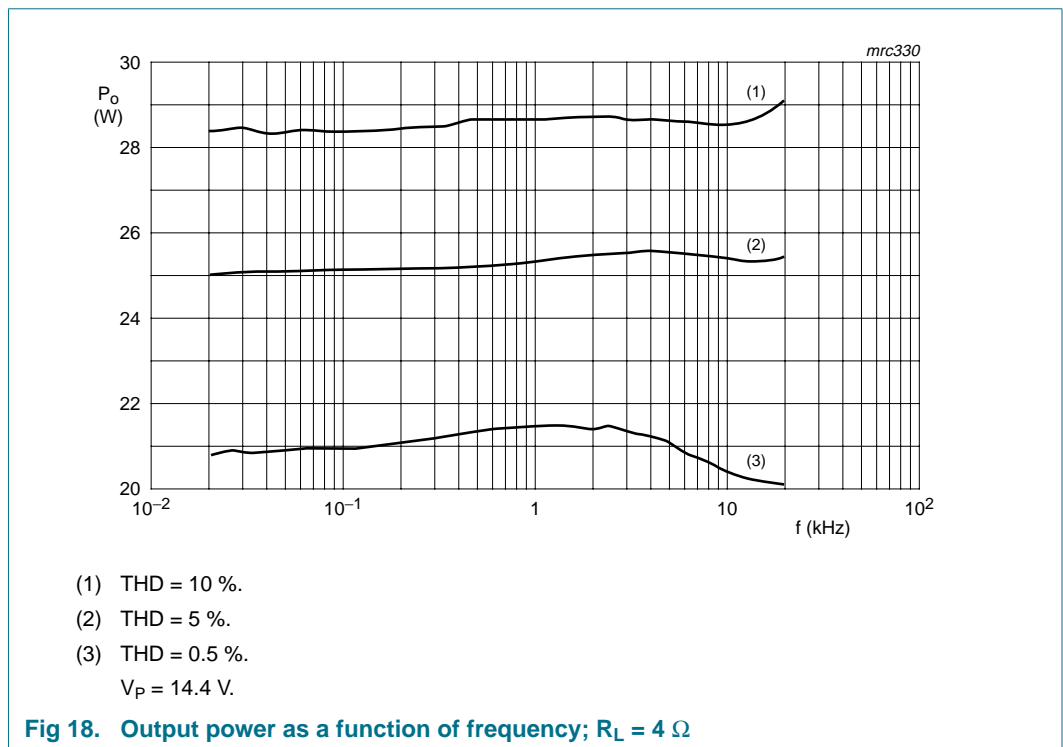
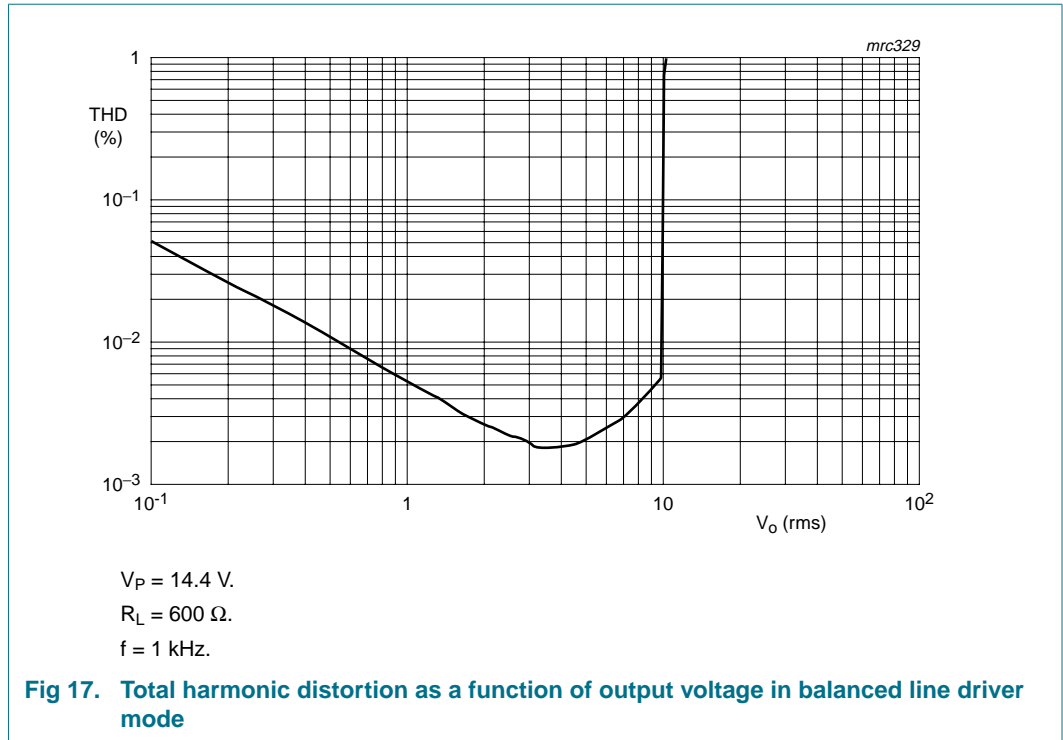
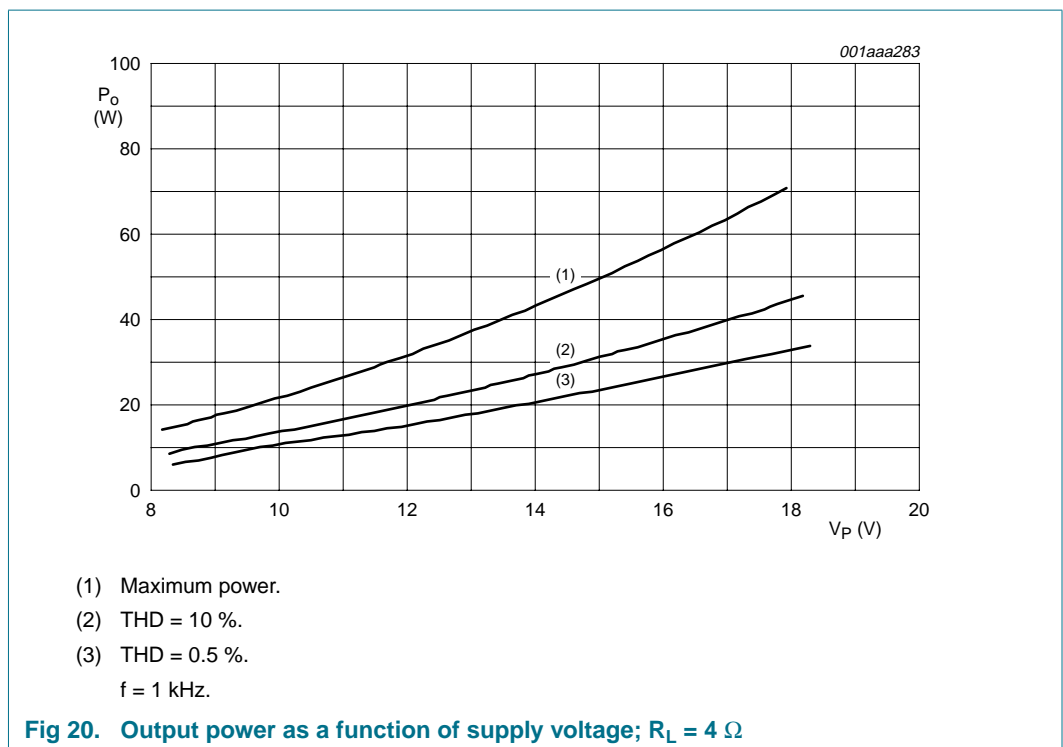
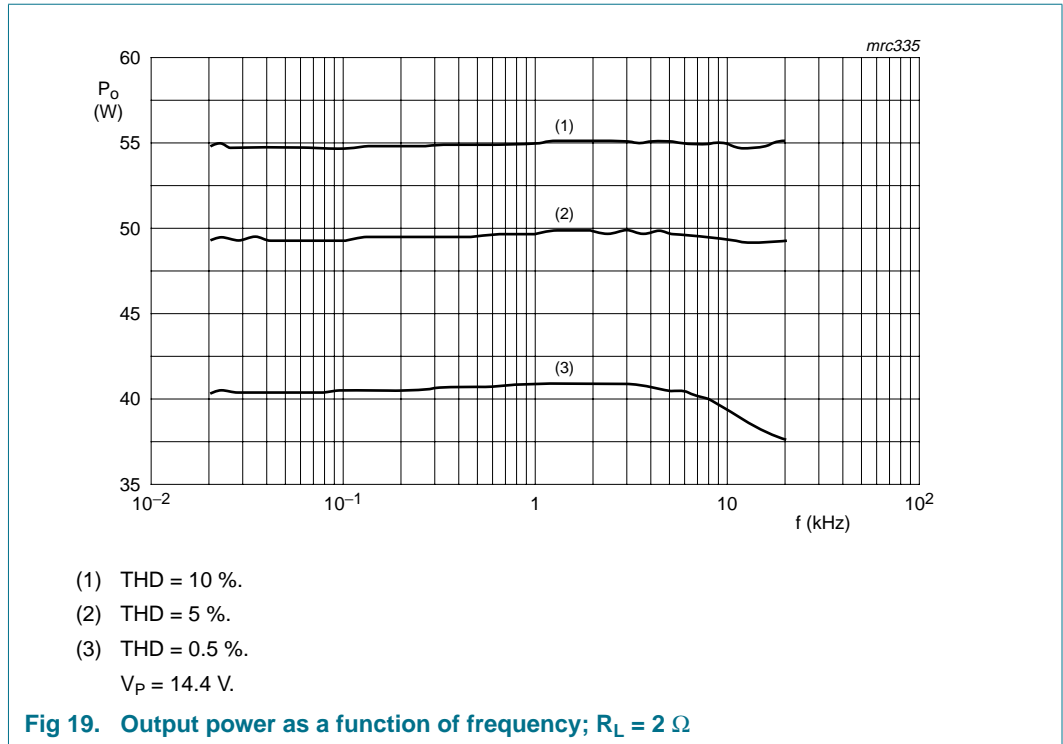
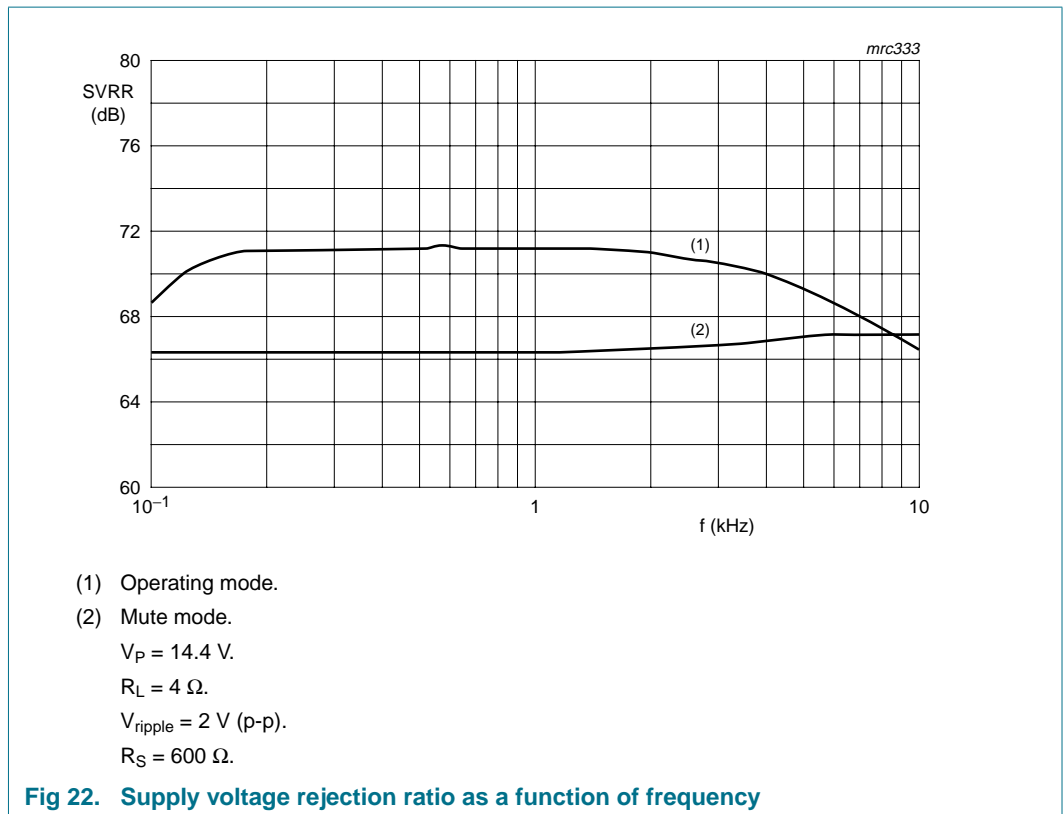
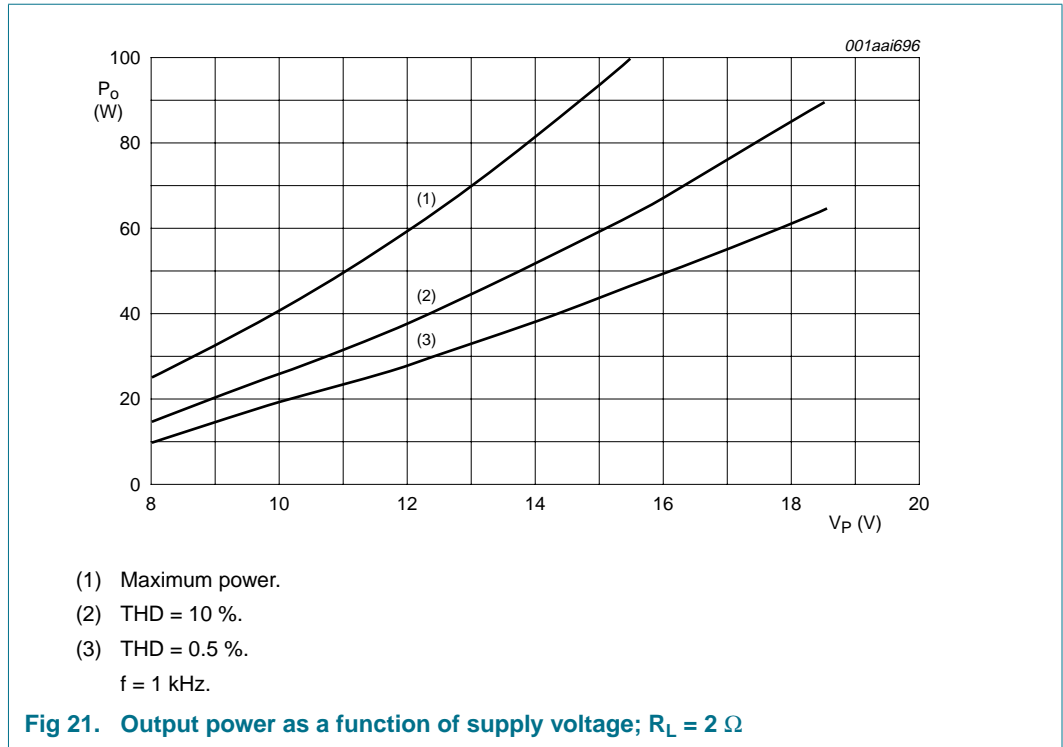

Fig 14. Low supply voltage behavior at $V_P < 5.5$ V









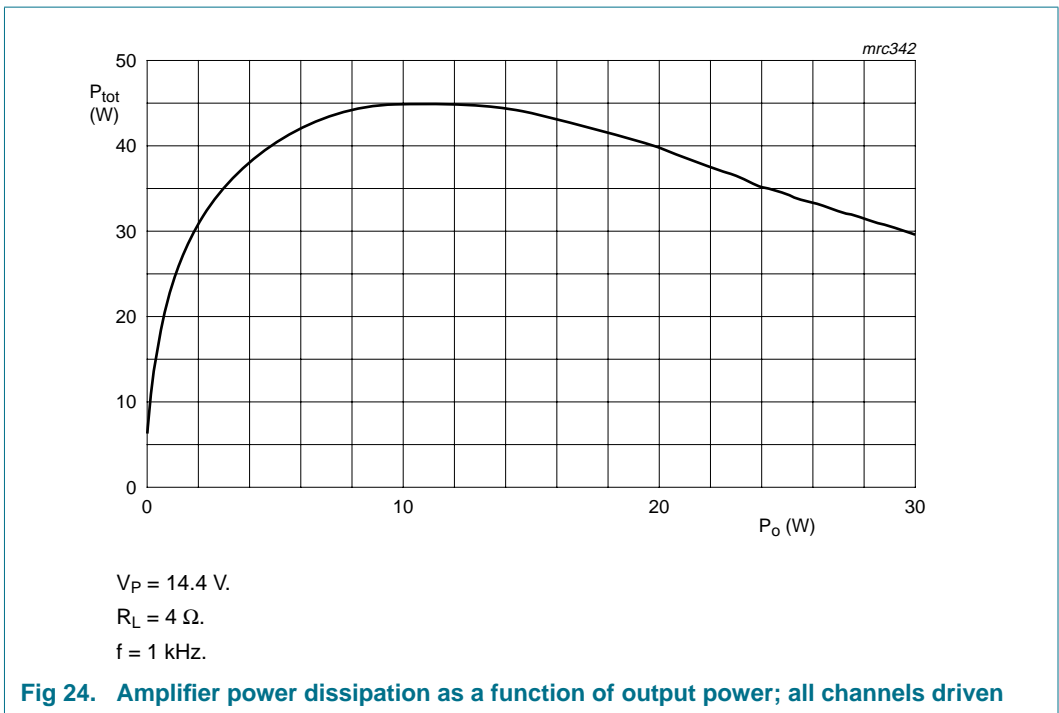
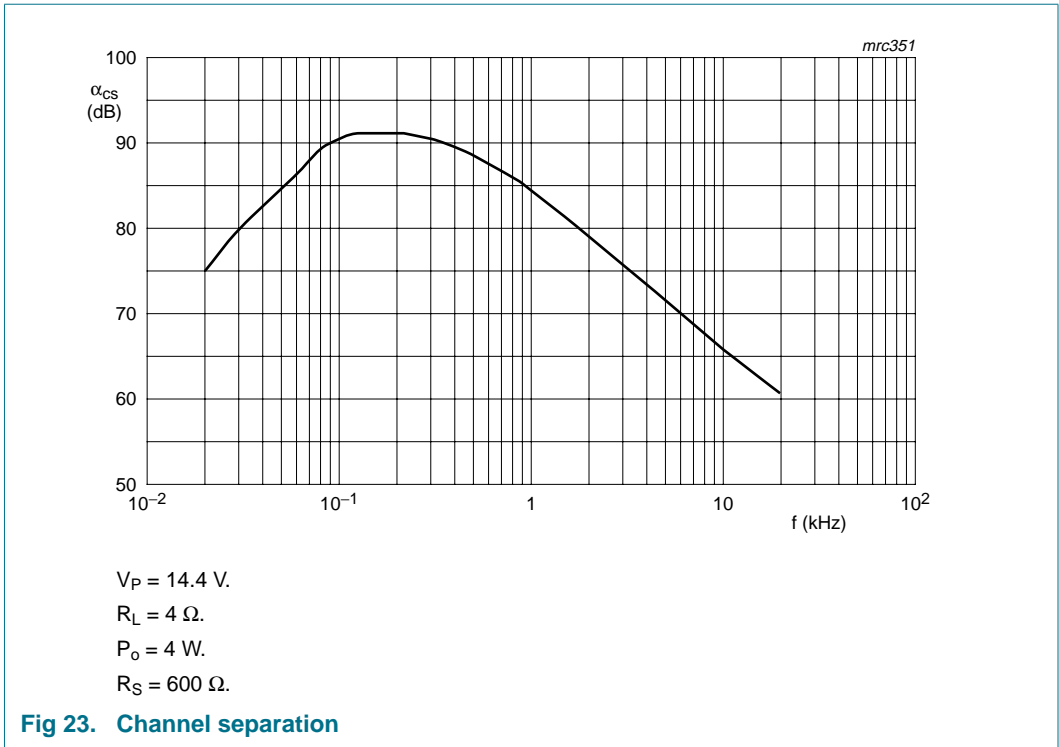

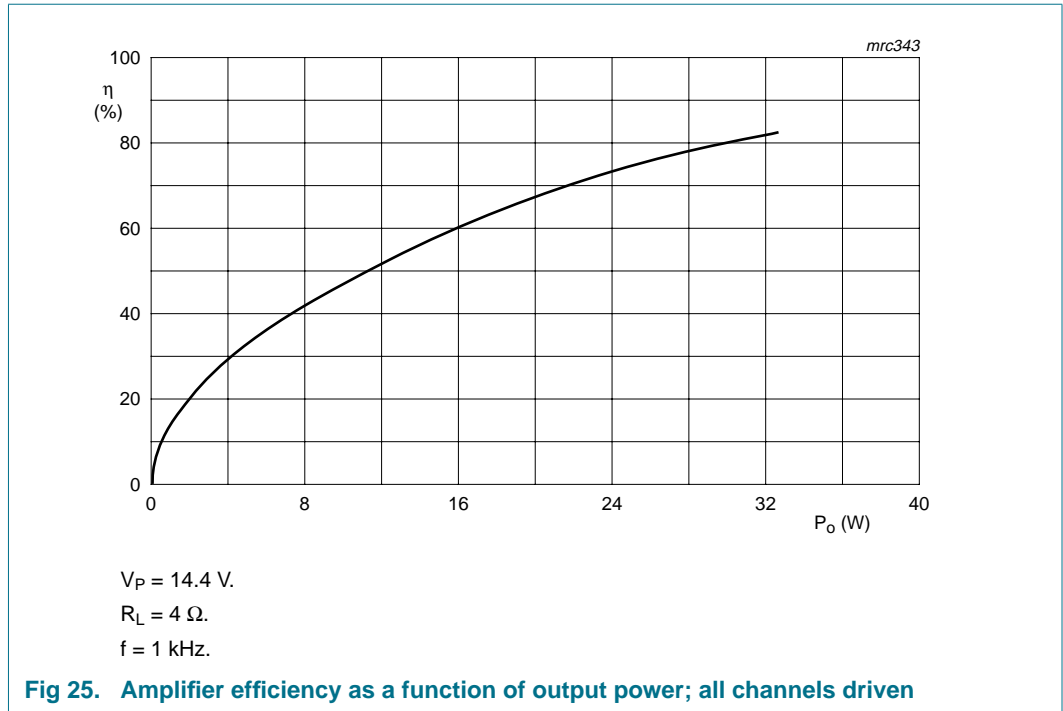

12. Application information

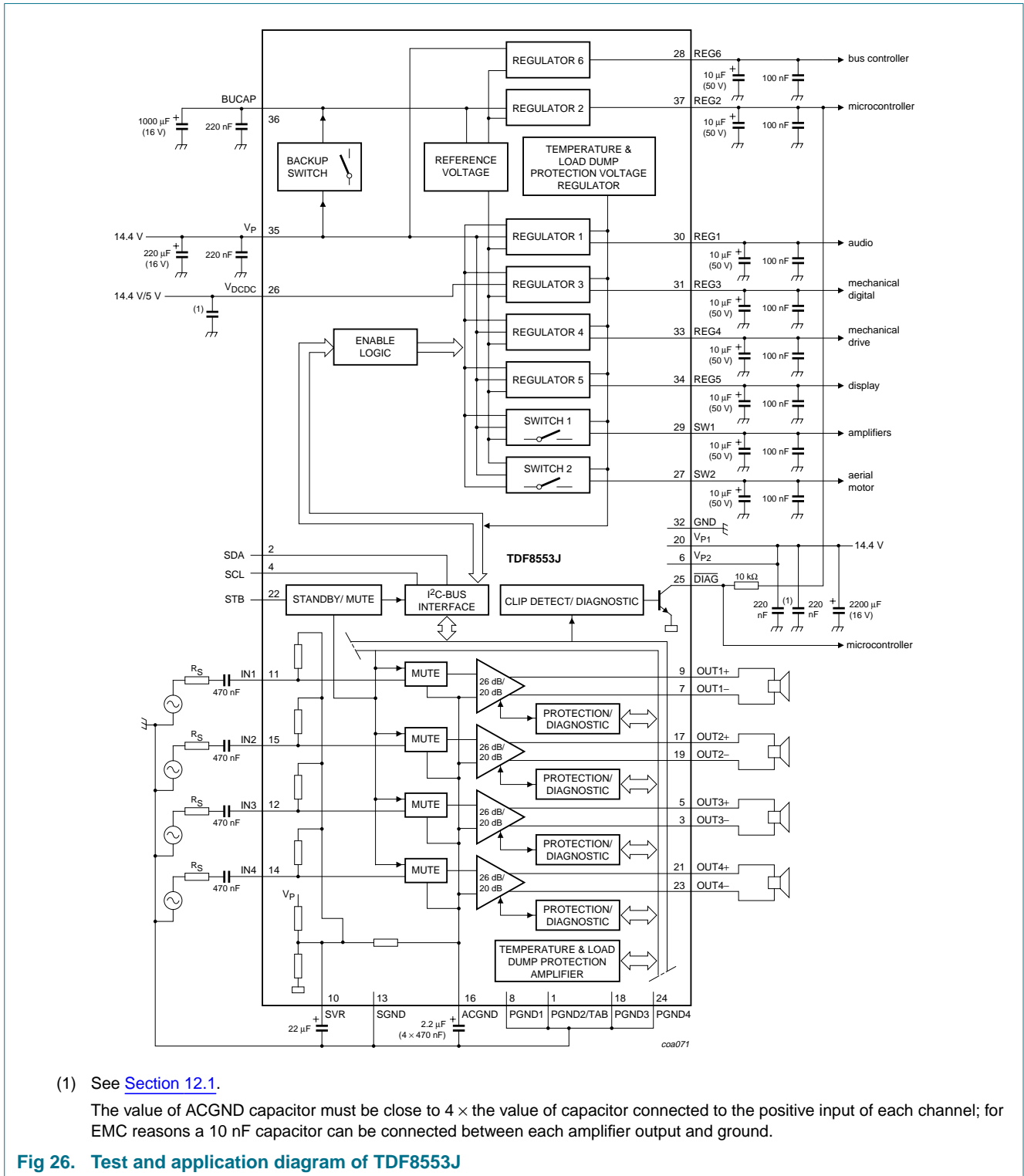

(1) See [Section 12.1](#).

The value of ACGND capacitor must be close to 4 × the value of capacitor connected to the positive input of each channel; for EMC reasons a 10 nF capacitor can be connected between each amplifier output and ground.

Fig 26. Test and application diagram of TDF8553J

12.1 Supply decoupling

See [Figure 26](#).

The high frequency 220 nF decoupling capacitors connected to power supply voltage pins 6 and 20 should be located as close as possible to these pins.

It is important to use good quality capacitors. These capacitors should be able to suppress high voltage peaks that can occur on the power supply if several audio channels are accidentally shorted to the power supply simultaneously, due to the activation of current protection. Good results have been achieved using 0805 case-size capacitors (X7R material, 220 nF) located close to power supply voltage pins 6 and 20.

If a DC-to-DC converter is used to supply regulator 3, the recommendations of the converter manufacturer relating to decoupling must be followed.

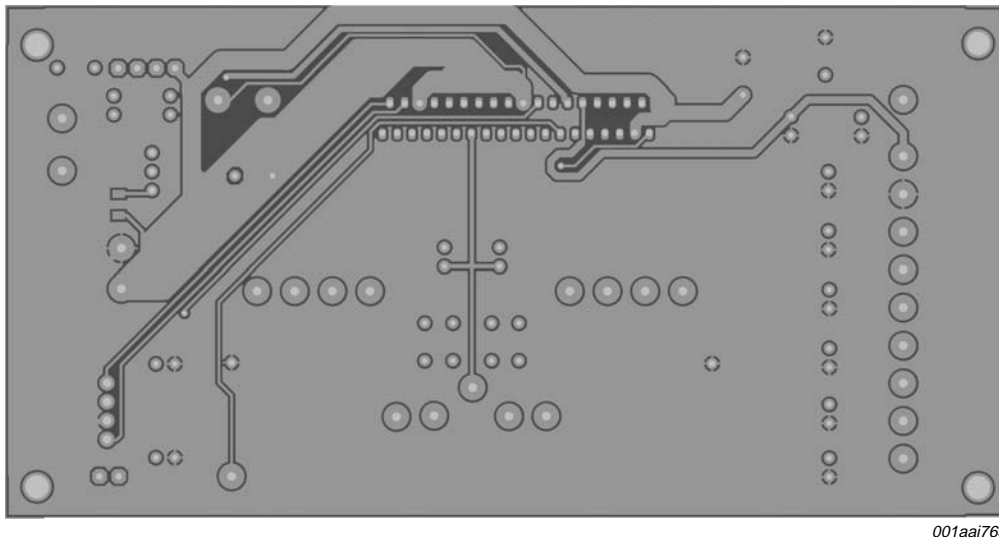

001aai763

Fig 27. Printed-circuit board layout of test and application circuit showing top copper layer viewed from top

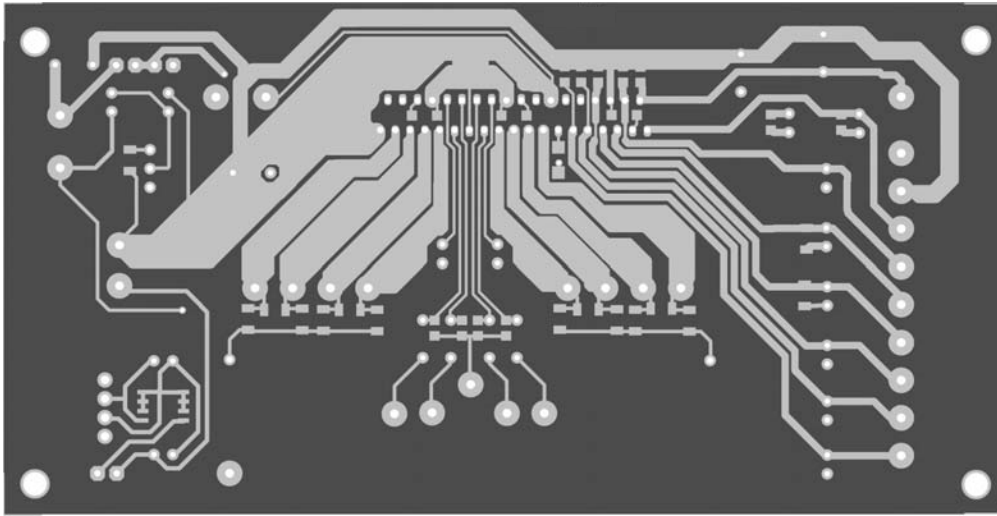

001ai762

Fig 28. Printed-circuit board layout of test and application circuit showing bottom copper layer viewed from top

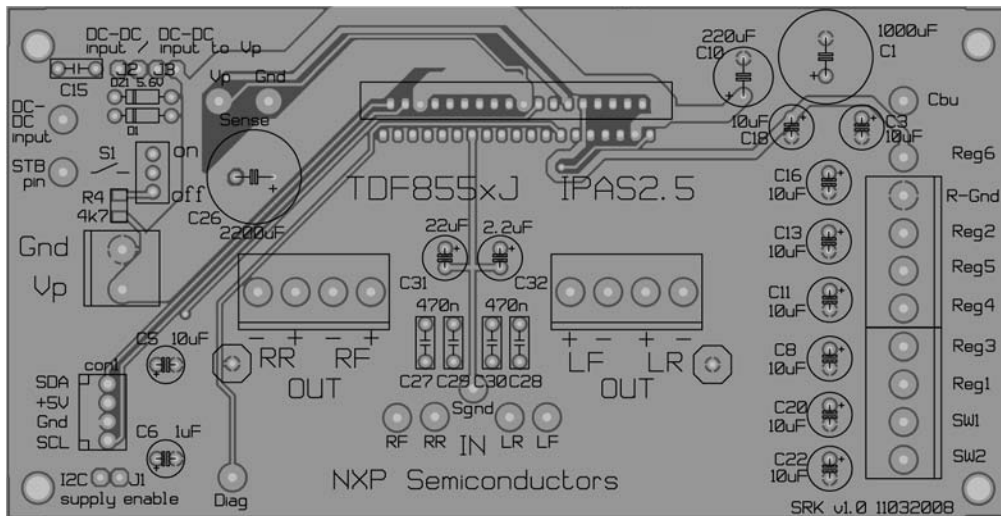

001ai764

Fig 29. Printed-circuit board layout of test and application circuit showing components and top copper layout viewed from top

Table 17. Regulator noise figures

Regulator	Noise figure (μV) [1]		
	$C_o = 10 \mu\text{F}$	$C_o = 47 \mu\text{F}$	$C_o = 100 \mu\text{F}$
1	225	180	145
2	700	600	390
3	100	85	65
4	235	205	175
5	315	285	225
6	710	550	340

[1] Measured in the frequency range 20 Hz to 80 kHz; at $I_{O(\text{reg})} = 10 \text{ mA}$

12.4 Stability

The regulators are made stable by connecting capacitors to the regulator outputs. The stability can be guaranteed with almost any output capacitor if its Electric Series Resistance (ESR) stays below the ESR curve shown in Figure 32. If an electrolytic capacitor is used, its behavior with temperature can cause oscillations at extremely low temperature. Oscillation problems can be avoided by adding a 47 nF capacitor in parallel with the electrolytic capacitor. The following example describes how to select the value of output capacitor.

12.4.1 Example regulator 2

Regulator 2 is stabilized with an electrolytic output capacitor of 10 μF which has an ESR of 4 Ω . At $T_{\text{amb}} = -30 \text{ }^\circ\text{C}$ the capacitor value decreases to 3 μF and its ESR increases to 28 Ω which is above the maximum allowed as shown in Figure 32, and which will make the regulator unstable. To avoid problems with stability at low temperatures, the recommended solution is to use tantalum capacitors. Either use a tantalum capacitor of 10 μF , or an electrolytic capacitor with a higher value.

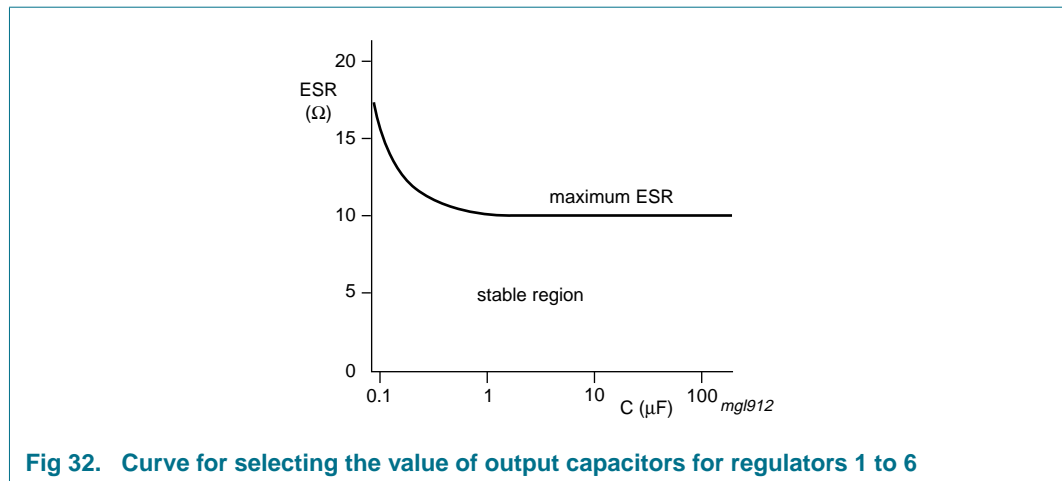

Fig 32. Curve for selecting the value of output capacitors for regulators 1 to 6

13. Package outline

DBS37P: plastic DIL-bent-SIL power package; 37 leads (lead length 6.8 mm)

SOT725-1

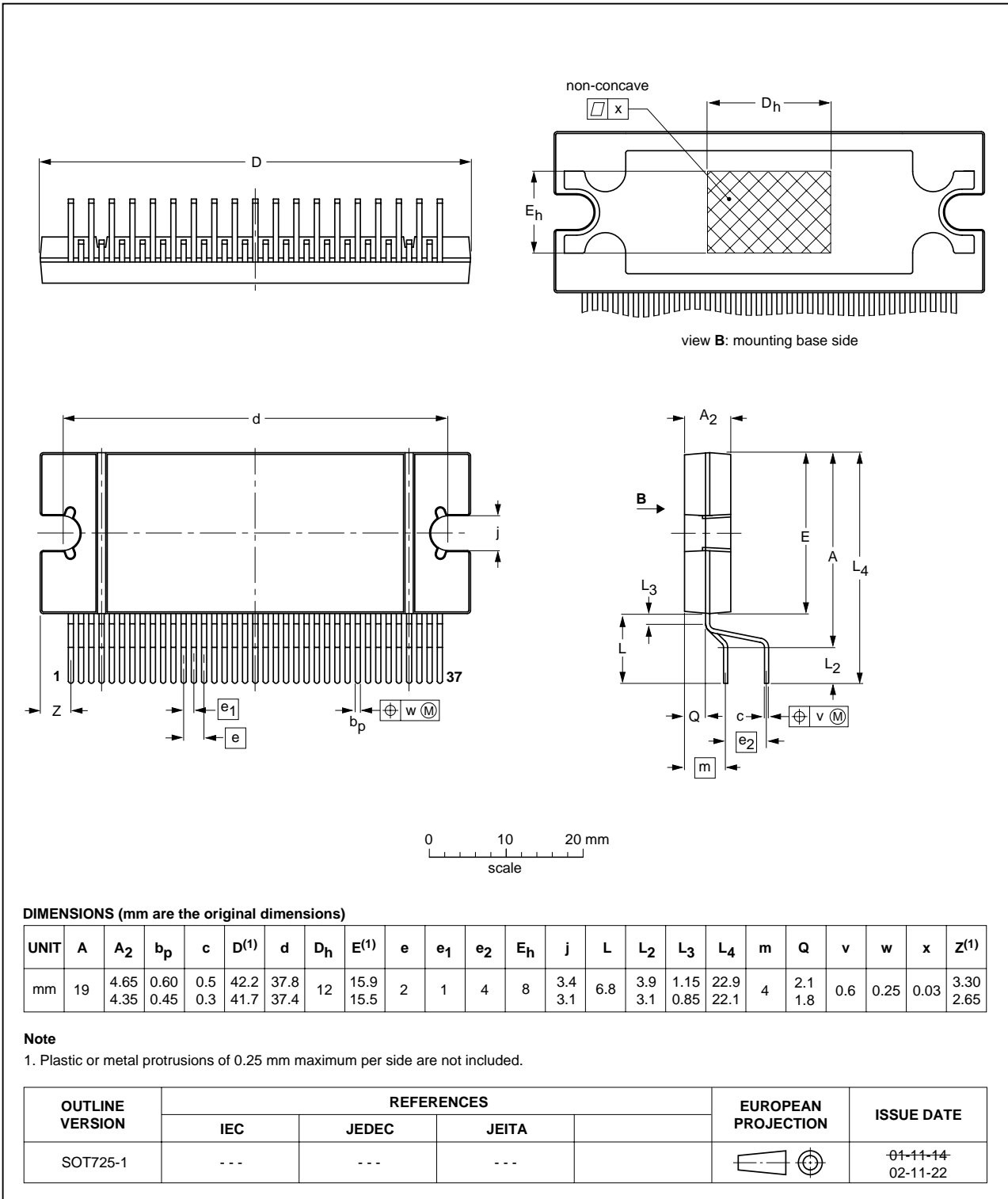

Fig 33. Package outline SOT725-1 (DBS37P)

14. Soldering of through-hole mount packages

14.1 Introduction to soldering through-hole mount packages

This text gives a very brief insight into wave, dip and manual soldering.

Wave soldering is the preferred method for mounting of through-hole mount IC packages on a printed-circuit board.

14.2 Soldering by dipping or by solder wave

Driven by legislation and environmental forces the worldwide use of lead-free solder pastes is increasing. Typical dwell time of the leads in the wave ranges from 3 seconds to 4 seconds at 250 °C or 265 °C, depending on solder material applied, SnPb or Pb-free respectively.

The total contact time of successive solder waves must not exceed 5 seconds.

The device may be mounted up to the seating plane, but the temperature of the plastic body must not exceed the specified maximum storage temperature ($T_{stg(max)}$). If the printed-circuit board has been pre-heated, forced cooling may be necessary immediately after soldering to keep the temperature within the permissible limit.

14.3 Manual soldering

Apply the soldering iron (24 V or less) to the lead(s) of the package, either below the seating plane or not more than 2 mm above it. If the temperature of the soldering iron bit is less than 300 °C it may remain in contact for up to 10 seconds. If the bit temperature is between 300 °C and 400 °C, contact may be up to 5 seconds.

14.4 Package related soldering information

Table 18. Suitability of through-hole mount IC packages for dipping and wave soldering

Package	Soldering method	
	Dipping	Wave
CPGA, HCPGA	-	suitable
DBS, DIP, HDIP, RDBS, SDIP, SIL	suitable	suitable ^[1]
PMFP ^[2]	-	not suitable

[1] For SDIP packages, the longitudinal axis must be parallel to the transport direction of the printed-circuit board.

[2] For PMFP packages hot bar soldering or manual soldering is suitable.

15. Abbreviations

Table 19. Abbreviations

Acronym	Description
BCDMOS	Bipolar CMOS DMOS MOS
CMOS	Complementary Metal-Oxide Semiconductor
DMOS	Double-Diffused Metal-Oxide Semiconductor
EMC	ElectroMagnetic Compatibility
MOS	Metal-Oxide Semiconductor
POR	Power-On Reset

16. Revision history

Table 20. Revision history

Document ID	Release date	Data sheet status	Change notice	Supersedes
TDF8553J_1	20081203	Objective data sheet	-	-

17. Legal information

17.1 Data sheet status

Document status ^{[1][2]}	Product status ^[3]	Definition
Objective [short] data sheet	Development	This document contains data from the objective specification for product development.
Preliminary [short] data sheet	Qualification	This document contains data from the preliminary specification.
Product [short] data sheet	Production	This document contains the product specification.

[1] Please consult the most recently issued document before initiating or completing a design.

[2] The term 'short data sheet' is explained in section "Definitions".

[3] The product status of device(s) described in this document may have changed since this document was published and may differ in case of multiple devices. The latest product status information is available on the Internet at URL <http://www.nxp.com>.

17.2 Definitions

Draft — The document is a draft version only. The content is still under internal review and subject to formal approval, which may result in modifications or additions. NXP Semiconductors does not give any representations or warranties as to the accuracy or completeness of information included herein and shall have no liability for the consequences of use of such information.

Short data sheet — A short data sheet is an extract from a full data sheet with the same product type number(s) and title. A short data sheet is intended for quick reference only and should not be relied upon to contain detailed and full information. For detailed and full information see the relevant full data sheet, which is available on request via the local NXP Semiconductors sales office. In case of any inconsistency or conflict with the short data sheet, the full data sheet shall prevail.

17.3 Disclaimers

General — Information in this document is believed to be accurate and reliable. However, NXP Semiconductors does not give any representations or warranties, expressed or implied, as to the accuracy or completeness of such information and shall have no liability for the consequences of use of such information.

Right to make changes — NXP Semiconductors reserves the right to make changes to information published in this document, including without limitation specifications and product descriptions, at any time and without notice. This document supersedes and replaces all information supplied prior to the publication hereof.

Suitability for use — NXP Semiconductors products are not designed, authorized or warranted to be suitable for use in medical, military, aircraft, space or life support equipment, nor in applications where failure or malfunction of an NXP Semiconductors product can reasonably be expected to result in personal injury, death or severe property or environmental

damage. NXP Semiconductors accepts no liability for inclusion and/or use of NXP Semiconductors products in such equipment or applications and therefore such inclusion and/or use is at the customer's own risk.

Applications — Applications that are described herein for any of these products are for illustrative purposes only. NXP Semiconductors makes no representation or warranty that such applications will be suitable for the specified use without further testing or modification.

Limiting values — Stress above one or more limiting values (as defined in the Absolute Maximum Ratings System of IEC 60134) may cause permanent damage to the device. Limiting values are stress ratings only and operation of the device at these or any other conditions above those given in the Characteristics sections of this document is not implied. Exposure to limiting values for extended periods may affect device reliability.

Terms and conditions of sale — NXP Semiconductors products are sold subject to the general terms and conditions of commercial sale, as published at <http://www.nxp.com/profile/terms>, including those pertaining to warranty, intellectual property rights infringement and limitation of liability, unless explicitly otherwise agreed to in writing by NXP Semiconductors. In case of any inconsistency or conflict between information in this document and such terms and conditions, the latter will prevail.

No offer to sell or license — Nothing in this document may be interpreted or construed as an offer to sell products that is open for acceptance or the grant, conveyance or implication of any license under any copyrights, patents or other industrial or intellectual property rights.

Quick reference data — The Quick reference data is an extract of the product data given in the Limiting values and Characteristics sections of this document, and as such is not complete, exhaustive or legally binding.

17.4 Trademarks

Notice: All referenced brands, product names, service names and trademarks are the property of their respective owners.

I²C-bus — logo is a trademark of NXP B.V.

18. Contact information

For more information, please visit: <http://www.nxp.com>

For sales office addresses, please send an email to: salesaddresses@nxp.com

19. Contents

1	General description	1	12.4.1	Example regulator 2	42
1.1	Amplifiers	1	13	Package outline	43
1.2	Voltage regulators	1	14	Soldering of through-hole mount packages	44
2	Features	1	14.1	Introduction to soldering through-hole mount packages	44
3	Applications	2	14.2	Soldering by dipping or by solder wave	44
4	Quick reference data	2	14.3	Manual soldering	44
5	Ordering information	4	14.4	Package related soldering information	44
6	Block diagram	5	15	Abbreviations	45
7	Pinning information	6	16	Revision history	45
7.1	Pinning	6	17	Legal information	46
7.2	Pin description	7	17.1	Data sheet status	46
8	Functional description	8	17.2	Definitions	46
8.1	Start-up	8	17.3	Disclaimers	46
8.2	Start-up and shut-down timing	8	17.4	Trademarks	46
8.3	Power-on reset and supply voltage spikes	8	18	Contact information	46
8.4	Diagnostic output	8	19	Contents	47
8.5	Amplifiers	9			
8.5.1	Muting	9			
8.5.2	Temperature protection	9			
8.5.3	Offset detection	9			
8.5.4	Speaker protection	9			
8.5.5	Line driver mode	9			
8.5.6	Input and AC ground capacitor values	10			
8.5.7	Load detection	10			
8.5.7.1	DC-load detection	10			
8.5.7.2	AC-load detection	10			
8.5.7.3	Load detection procedure	11			
8.5.8	Low headroom protection	11			
8.6	Voltage regulators	12			
8.6.1	Standby regulator outputs	12			
8.6.2	Backup capacitor	12			
8.6.3	Backup function	13			
8.6.4	Power switches	13			
8.6.5	External DC-to-DC converter	14			
8.6.6	Protection	14			
8.6.7	Temperature protection	14			
8.7	I ² C-bus specification	14			
9	Limiting values	21			
10	Thermal characteristics	22			
10.1	Quality specification	22			
11	Characteristics	23			
12	Application information	38			
12.1	Supply decoupling	39			
12.2	Beep input circuit	41			
12.3	Noise	41			
12.4	Stability	42			

Please be aware that important notices concerning this document and the product(s) described herein, have been included in section 'Legal information'.

founded by

PHILIPS

© NXP B.V. 2008.

All rights reserved.

For more information, please visit: <http://www.nxp.com>

For sales office addresses, please send an email to: salesaddresses@nxp.com

Date of release: 3 December 2008

Document identifier: TDF8553J_1