

Silicon Epitaxial Planar Transistor

2SC4116W

FEATURES

- Excellent h_{FE} linearity.
- High voltage and current.
- Complementary to 2SA1586.
- Small package.

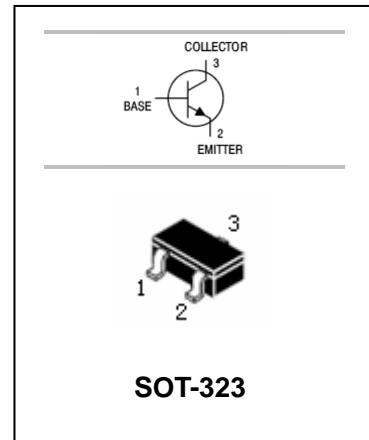

APPLICATIONS

- NPN Silicon Epitaxial Planar Transistor.

ORDERING INFORMATION

Type No.	Marking	Package Code
2SC4116W	LO/LY/LG/LL	SOT-323

MAXIMUM RATING @ $T_a=25^\circ\text{C}$ unless otherwise specified

Symbol	Parameter	Value	Units
V_{CBO}	Collector-Base Voltage	60	V
V_{CEO}	Collector-Emitter Voltage	50	V
V_{EBO}	Emitter-Base Voltage	5	V
I_C	Collector Current -Continuous	150	mA
P_C	Collector Dissipation	100	mW
T_j, T_{stg}	Junction and Storage Temperature	-55~125	$^\circ\text{C}$

ELECTRICAL CHARACTERISTICS @ $T_a=25^\circ\text{C}$ unless otherwise specified

Silicon Epitaxial Planar Transistor

2SC4116W

Parameter	Symbol	Test conditions	MIN	TYP	MAX	UNIT
Collector-base breakdown voltage	$V_{(BR)CBO}$	$I_C=100\mu A, I_E=0$	60			V
Collector-emitter breakdown voltage	$V_{(BR)CEO}$	$I_C=1mA, I_B=0$	50			V
Emitter-base breakdown voltage	$V_{(BR)EBO}$	$I_E=100\mu A, I_C=0$	5			V
Collector cut-off current	I_{CBO}	$V_{CB}=60V, I_E=0$			0.1	μA
Emitter cut-off current	I_{EBO}	$V_{EB}=5V, I_C=0$			0.1	μA
DC current gain	h_{FE}	$V_{CE}=6V, I_C=2mA$	70		700	
Collector-emitter saturation voltage	$V_{CE(sat)}$	$I_{CE}=100mA, I_B=10mA$		0.1	0.25	V
Transition frequency	f_T	$V_{CE}=10V, I_C=1mA$	80			MHz
Collector output capacitance	C_{ob}	$V_{CB}=10V, I_E=0, f=1MHz$		2.0	3.5	pF

CLASSIFICATION OF h_{FE}

Rank	O	Y	GR	BL
Range	70-140	120-240	200-400	350-700
Marking	LO	LY	LG	LL

TYPICAL CHARACTERISTICS @ $T_a=25^\circ C$ unless otherwise specified

Silicon Epitaxial Planar Transistor

2SC4116W

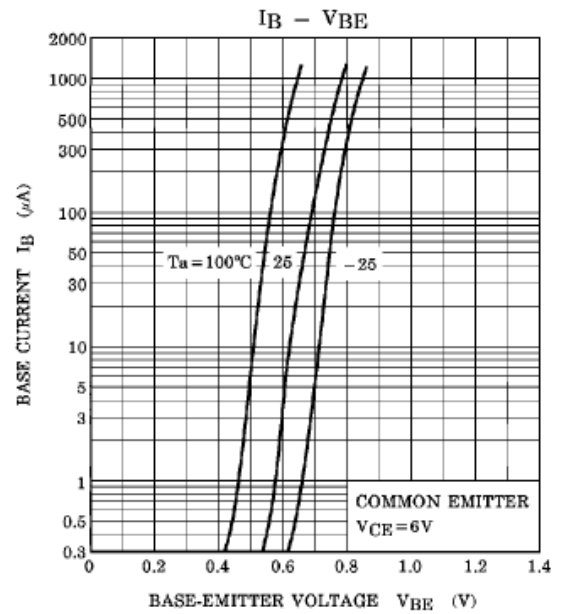
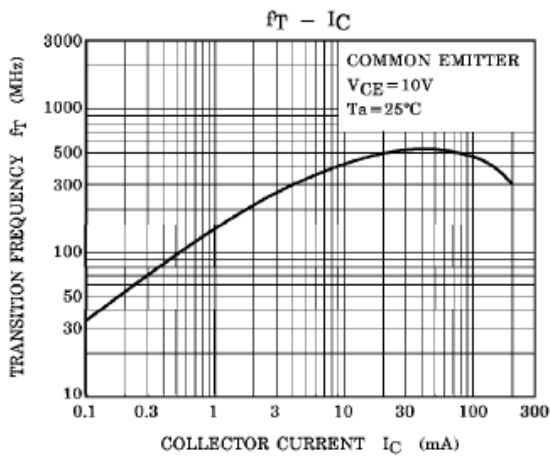
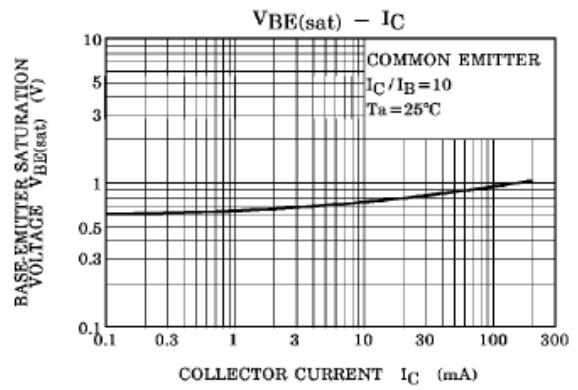
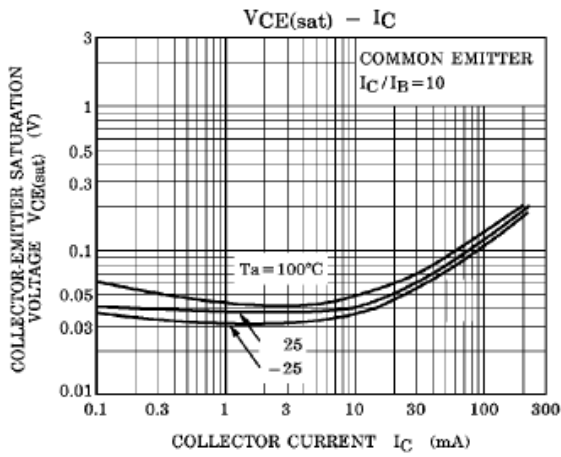
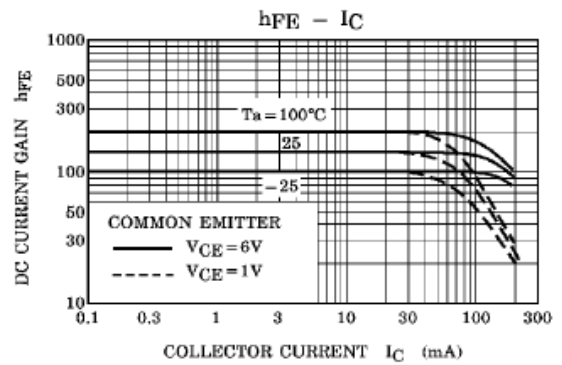
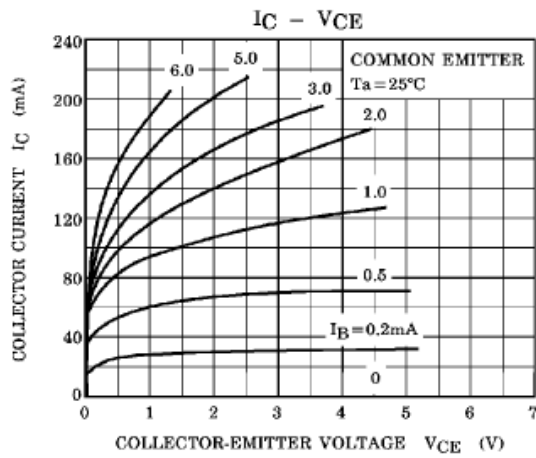

Silicon Epitaxial Planar Transistor

2SC4116W

PACKAGE OUTLINE

Plastic surface mounted package

SOT-323

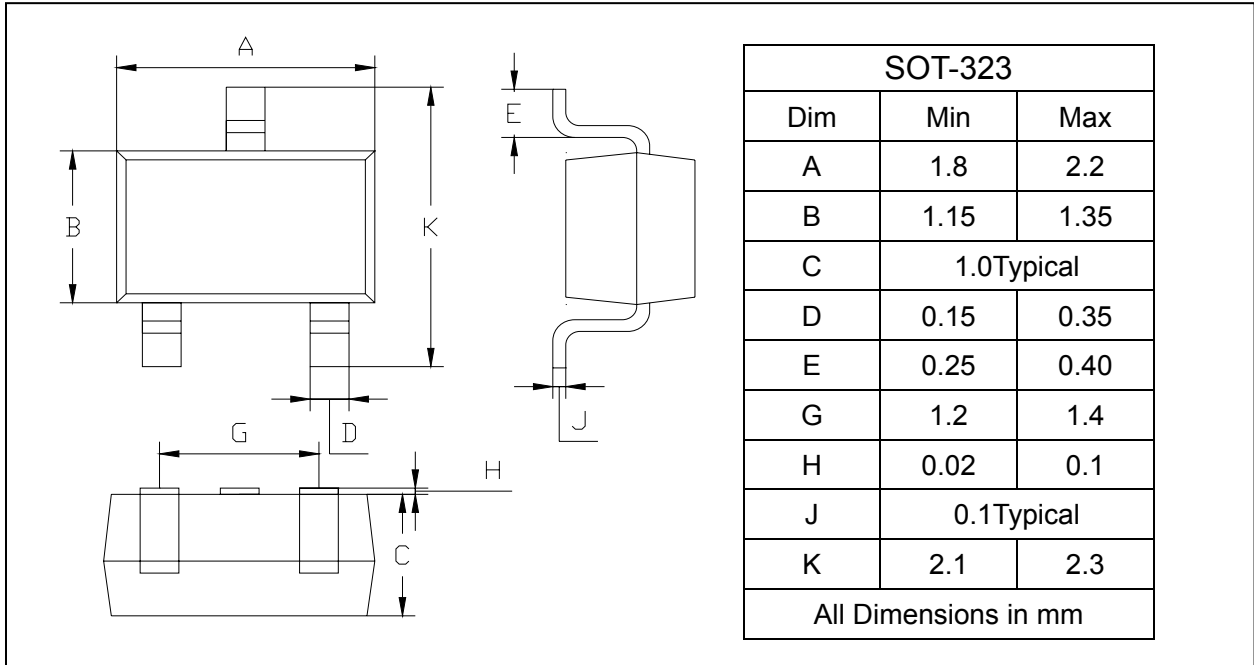

PACKAGE INFORMATION

Device	Package	Shipping
2SC4116W	SOT-323	3000/Tape&Reel