

Silicon PNP Power Transistors

BD896A/898A/900A

DESCRIPTION

- With TO-220C package
- Complement to type BD895A/897A/901A
- DARLINGTON

APPLICATIONS

- For use in output stages in audio equipment, general amplifier, and analogue switching applications

PINNING

PIN	DESCRIPTION
1	Base
2	Collector; connected to mounting base
3	Emitter

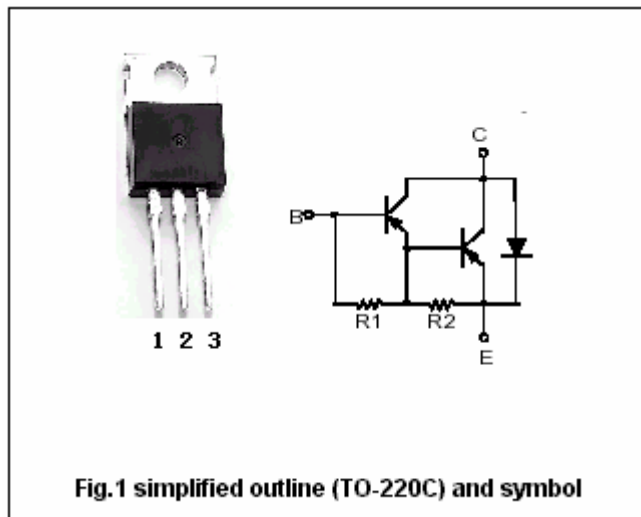

Fig.1 simplified outline (TO-220C) and symbol

Absolute maximum ratings(Ta=25)

SYMBOL	PARAMETER	CONDITIONS	VALUE	UNIT
V _{CBO}	Collector-base voltage	BD896A	-45	V
		BD898A	-60	
		BD900A	-80	
V _{CEO}	Collector-emitter voltage	BD896A	-45	V
		BD898A	-60	
		BD900A	-80	
V _{EBO}	Emitter-base voltage	Open collector	-5	V
I _C	Collector current-DC		-8	A
I _B	Base current		-300	mA
P _T	Total power dissipation	T _C =25	70	W
		T _a =25	2	
T _j	Junction temperature		150	
T _{stg}	Storage temperature		-65~150	

Silicon PNP Power Transistors

BD896A/898A/900A

CHARACTERISTICS

T_j=25 unless otherwise specified

SYMBOL	PARAMETER	CONDITIONS	MIN	TYP.	MAX	UNIT	
V _{(BR)CEO}	Collector-emitter breakdown voltage	BD896A	-45			V	
		BD898A	-60				
		BD900A	-80				
V _{CEsat}	Collector-emitter saturation voltage	I _C =-4A, I _B =-16mA			-2.8	V	
V _{BE}	Base-emitter on voltage	I _C =-4A; V _{CE} =-3V			-2.5	V	
I _{CBO}	Collector cut-off current	BD896A	V _{CB} =-45V, I _E =0 T _C =100			-0.2 -2.0	mA
		BD898A	V _{CB} =-60V, I _E =0 T _C =100			-0.2 -2.0	
		BD900A	V _{CB} =-80V, I _E =0 T _C =100			-0.2 -2.0	
I _{CEO}	Collector cut-off current	BD896A	V _{CE} =-30V, I _B =0			-0.5	mA
		BD898A	V _{CE} =-30V, I _B =0				
		BD900A	V _{CE} =-40V, I _B =0				
I _{EBO}	Emitter cut-off current	V _{EB} =-5V; I _C =0			-2	mA	
h _{FE}	DC current gain	I _C =-4A; V _{CE} =-3V	750				
V _{EC}	Diode forward voltage	I _E =-8A			-3.5	V	
t _{on}	Turn-on time	I _C =3A; I _{B1} =-I _{B2} =12mA		1		μs	
t _{off}	Turn-off time	V _{BE} =-3.5V; R _L =10Ω; t _p =20μs		5		μs	

THERMAL CHARACTERISTICS

SYMBOL	PARAMETER	MAX	UNIT
R _{th j-c}	Thermal resistance junction to case	1.79	/W

Silicon PNP Power Transistors

BD896A/898A/900A

PACKAGE OUTLINE

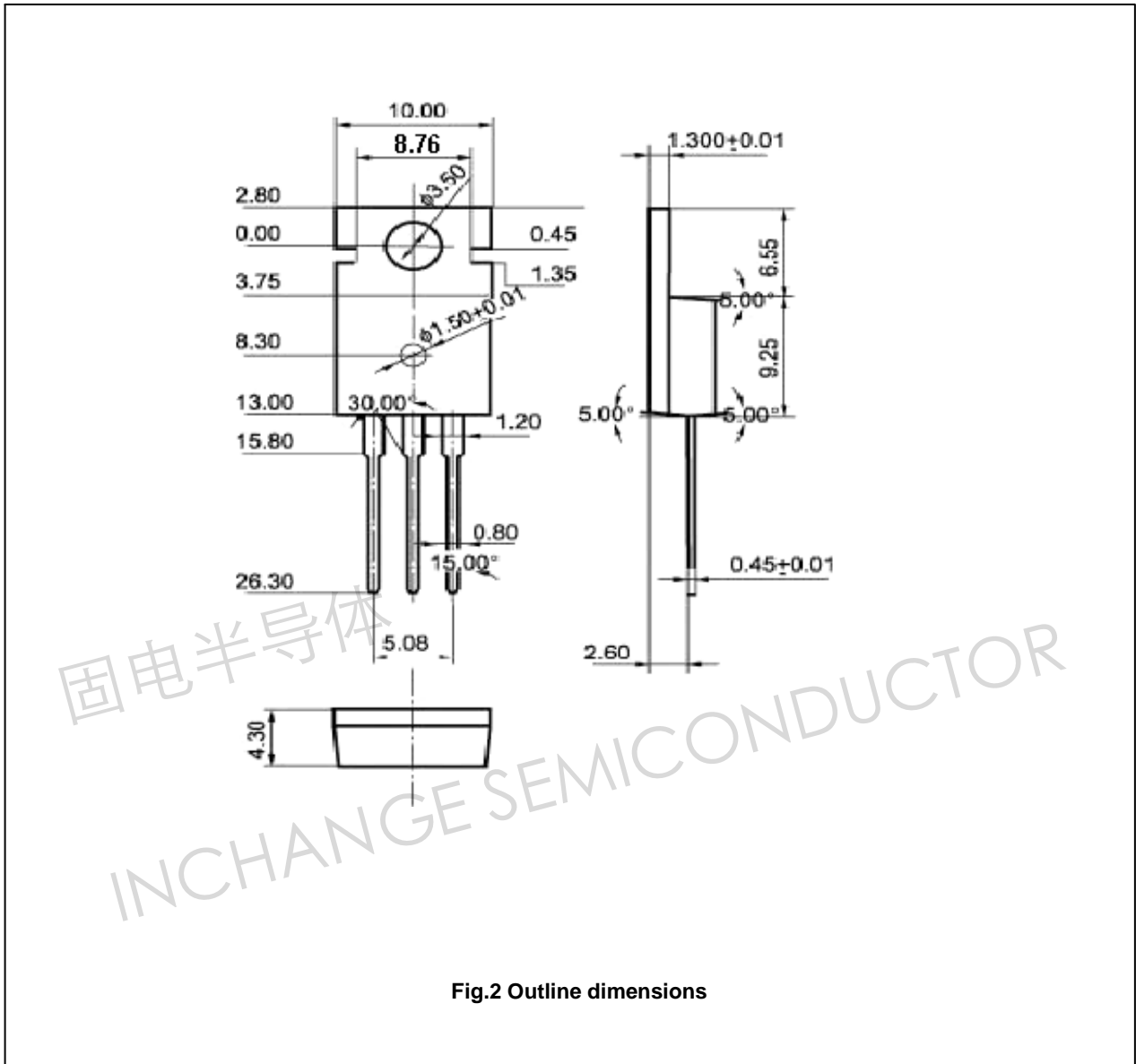

Fig.2 Outline dimensions