

**3.5V 400mA Low Dropout Regulator****Features**

- Dropout voltage typically 0.8V @ $I_o = 400\text{mA}$
- Output current in excess of 400mA
- Output voltage accuracy +3%/-2%
- Quiescent current, typically 600 μA
- Internal short circuit current limit
- Internal over temperature protection

General Description

The G930/G931 positive 3.5V voltage regulator features the ability to source 400mA of output current with a dropout voltage of typically 0.8V over the entire operating temperature range. A low quiescent current is provided over the entire output current range. The typical quiescent current is 0.6mA. Furthermore, the quiescent current is smaller when the regulator is in the dropout mode ($V_{IN} < 3.5\text{V}$).

Familiar regulator features such as over temperature and over current protection circuits are provided to prevent it from being damaged by abnormal operating conditions.

Ordering Information

ORDER NUMBER	ORDER NUMBER (Pb free)	PACKAGE TYPE	PIN OPTION		
			1	2	3
G930T21U	G930T21Uf	SOT-89	V_{OUT}	GND	V_{IN}
G931T24U	G931T24Uf	SOT-89	GND	V_{IN}	V_{OUT}

* For other package types, pin options and package, please contact us at sales @gmt.com.tw

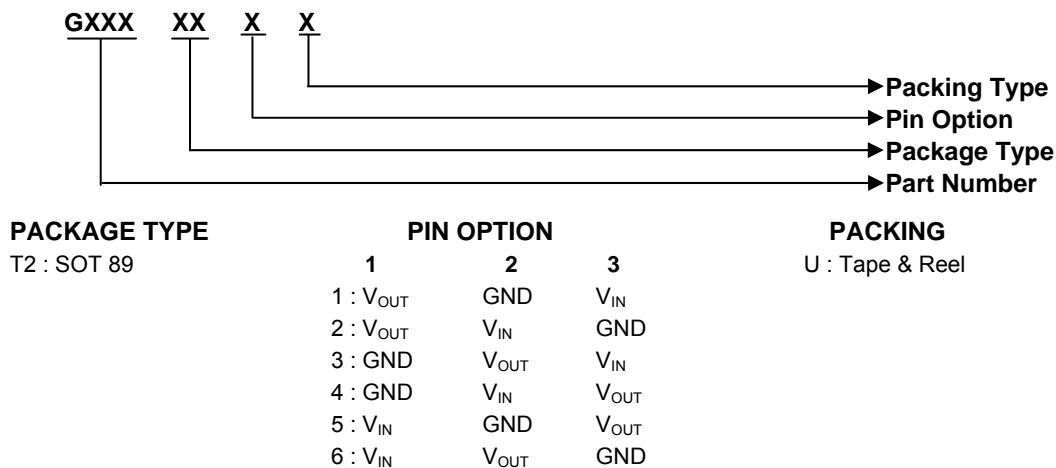
Order Number Identification**Typical Application**

[Note 4] : Type of C_{OUT}

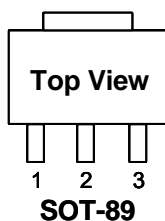
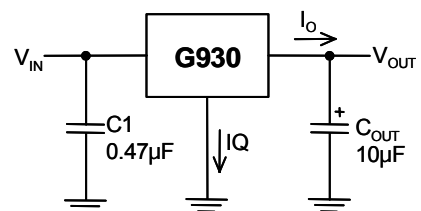
**Package Type**



Absolute Maximum Ratings	(Note 1)
Input Voltage	7V
Power Dissipation Internally Limited	(Note 2)
Maximum Junction Temperature	150°C
Storage Temperature Range	-65°C ≤ T _J ≤ +150°C
Reflow Temperature (soldering, 10sec)	260°C
Thermal Resistance Junction to Ambient, (θ _{JA})	
SOT-89	173°C/W ⁽¹⁾
Thermal Resistance Junction to Case, (θ _{Jc})	
SOT-89	25°C/W

Operating Conditions	(Note 1)
Input Voltage	4V~6V
Temperature Range	0°C ≤ T _J ≤ 125°C

Note ⁽¹⁾: See P.4 Recommended Minimum Footprint.

Electrical Characteristics

V_{IN} = 5V, I_O = 400mA, C_{IN} = 1μF, C_{OUT} = 10μF, All specifications apply for T_A = T_J = 25°C. [Note 3]

PARAMETER	CONDITIONS	MIN	TYP	MAX	UNITS
Output Voltage	5mA ≤ I _O ≤ 400mA	3.43	3.5	3.605	V
Line Regulation	4V ≤ V _{IN} ≤ 6V, I _O = 10mA	---	3	30	mV
Load Regulation	50mA ≤ I _O ≤ 400mA	---	35	50	mV
Quiescent Current	V _{IN} = 5V	0.3	0.6	1.5	mA
Ripple Rejection	f _r = 120Hz, 1V _{P-P} , I _O = 100mA	---	50	---	dB
Dropout Voltage	I _O = 400mA	---	0.8	0.9	V
	I _O = 100mA	---	125	---	mV
Short Circuit Current		---	1.6	---	A
Over Temperature		---	150	---	°C

Note 1: Absolute Maximum Ratings are limits beyond which damage to the device may occur. Operating Conditions are conditions under which the device functions but the specifications might not be guaranteed. For guaranteed specifications and test conditions see the Electrical Characteristics.

Note2: The maximum power dissipation is a function of the maximum junction temperature, T_{Jmax}; total thermal resistance, θ_{JA}, and ambient temperature T_A. The maximum allowable power dissipation at any ambient temperature is T_{Jmax}-T_A / θ_{JA}. If this dissipation is exceeded, the die temperature will rise above 150°C and IC will go into thermal shutdown. For the G930/G931 in SOT-89 package, θ_{JA} is 173°C/W. (See Recommended Minimum Footprint). The safe operation in SOT-89, it can see "Typical Performance Characteristics".

Note3: Low duty pulse techniques are used during test to maintain junction temperature as close to ambient as possible.

Note4: The type of output capacitor should be tantalum or aluminum.

Definitions

Dropout Voltage

The input/output Voltage differential at which the regulator output no longer maintains regulation against further reductions in input voltage. Measured when the output drops 100mV below its nominal value, dropout voltage is affected by junction temperature, load current and minimum input supply requirements.

Line Regulation

The change in output voltage for a change in input voltage. The measurement is made under conditions of low dissipation or by using pulse techniques such that average chip temperature is not significantly affected.

Load Regulation

The change in output voltage for a change in load current at constant chip temperature. The measurement is made under conditions of low dissipation or by using pulse techniques such that average chip temperature is not significantly affected.

Maximum Power Dissipation

The maximum total device dissipation for which the regulator will operate within specifications.

Quiescent Bias Current

Current which is used to operate the regulator chip and is not delivered to the load.



Typical Performance Characteristics

(VIN=5V, CIN=1μF, COUT=10μF, TA=25°C, unless otherwise noted.)

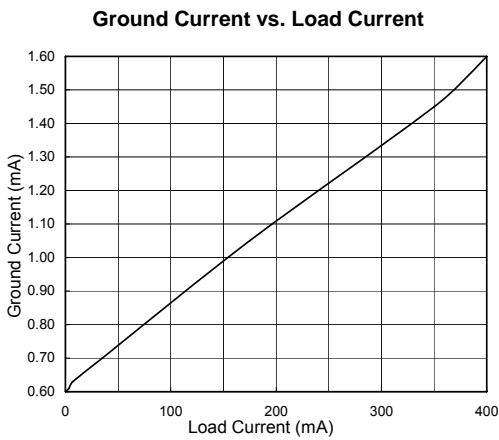
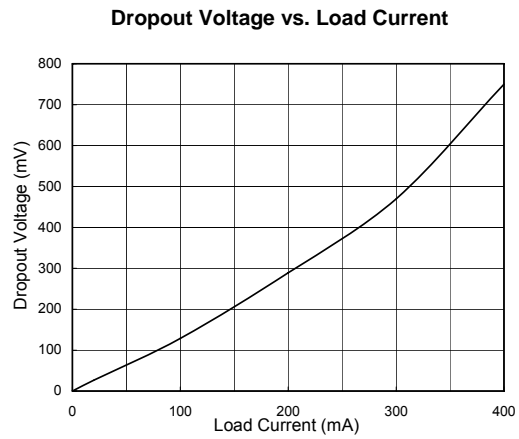
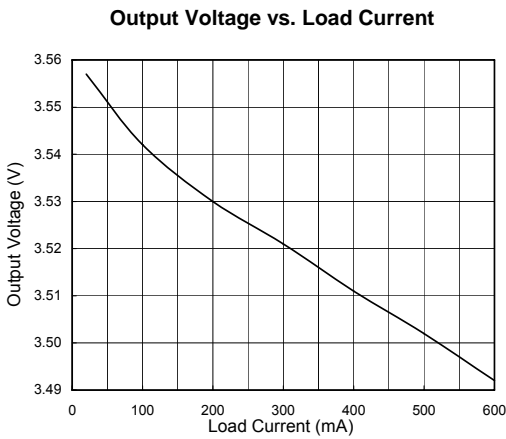
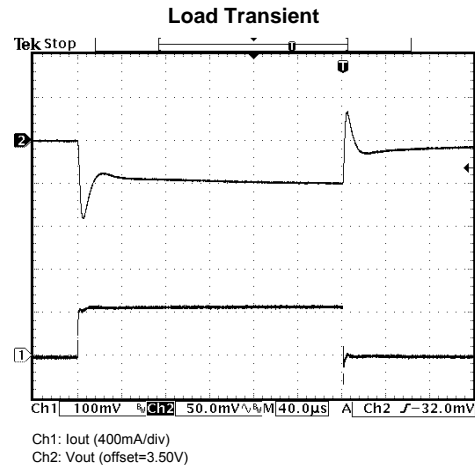
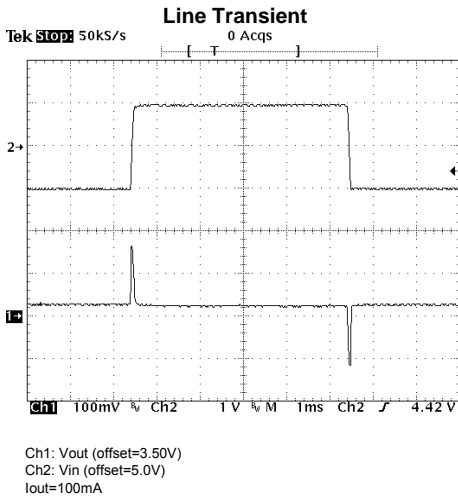

Typical Performance Characteristics (continued)

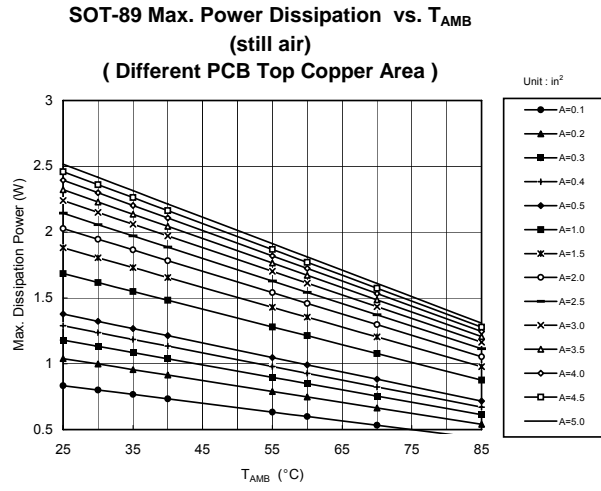
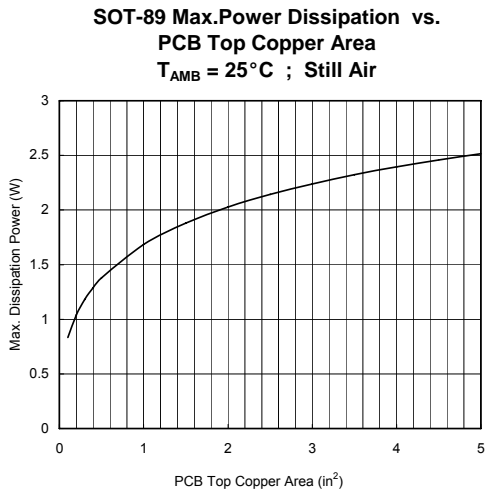

Recommended Minimum Footprint

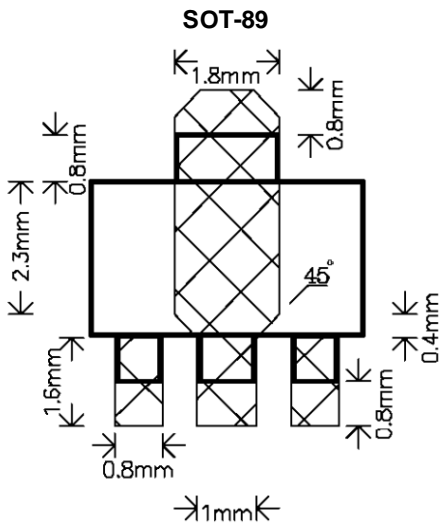

Package Information

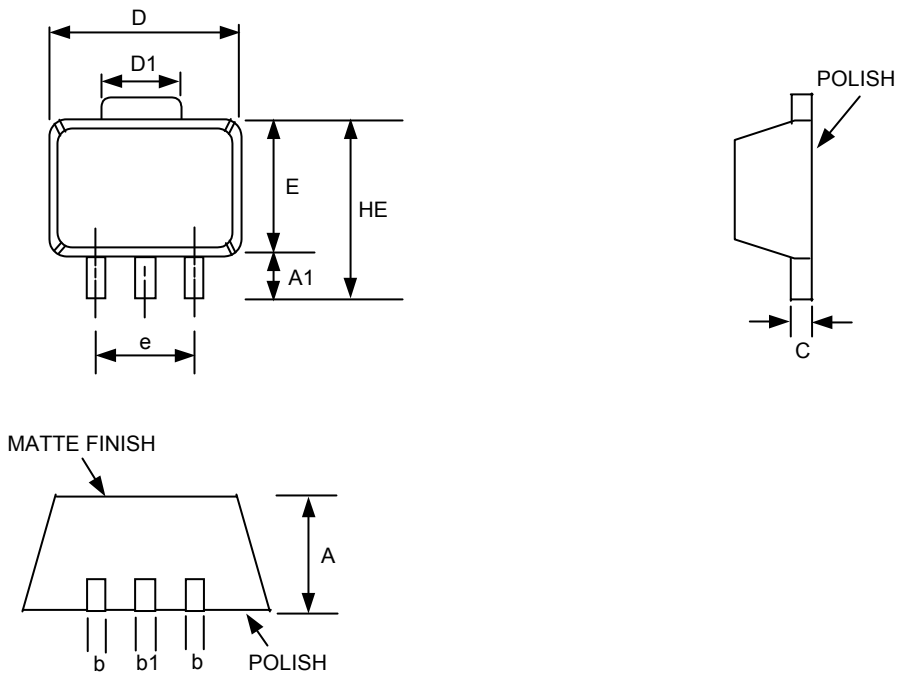

SOT- 89 (T2) Package

SYMBOLS	DIMENSIONS IN MILLIMETERS			DIMENSIONS IN INCHES		
	MIN	NOM	MAX	MIN	NOM	MAX
A	1.40	1.50	1.60	0.055	0.059	0.063
A1	0.80	1.04	-----	0.031	0.041	-----
b	0.36	0.42	0.48	0.014	0.016	0.018
b1	0.41	0.47	0.53	0.016	0.018	0.020
C	0.38	0.40	0.43	0.014	0.015	0.017
D	4.40	4.50	4.60	0.173	0.177	0.181
D1	1.40	1.60	1.75	0.055	0.062	0.069
HE	-----	-----	4.25	-----	-----	0.167
E	2.40	2.50	2.60	0.094	0.098	0.102
e	2.90	3.00	3.10	0.114	0.118	0.122

Package Specification

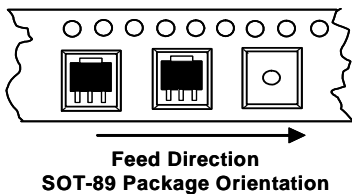

PACKAGE	Q'TY/REEL
SOT-89	1,000 ea

GMT Inc. does not assume any responsibility for use of any circuitry described, no circuit patent licenses are implied and GMT Inc. reserves the right at any time without notice to change said circuitry and specifications.