

### APPLICATIONS

- *Battery Backup*
- *Battery Alternative*
- *Audio Systems*
- *Pulse Power*
- *DC-DC Converters*
- *Mechanical Actuators*

### FEATURES

- *High Capacitance*
- *Long Life*
- *Low ESR*
- *High Power Density*
- *Very Fast Charge/discharge Cycling*
- *Circuit Board Mountable*
- *Compact Size*
- *RoHS Compliant*

### SPECIFICATIONS

Operating Temperature Range		-40°C to +60°C -40°C to +65°C for 407DCN2R7K			
Storage Temperature		-40°C to +70°C			
Capacitance Tolerance		+30%/-10% @ 25°C ±10% for 407DCN2R7K			
Surge Voltage	WVDC	2.7	5.4		
	SVDC	2.85	5.7		
Rated Current (5 second discharge to 1/2 WVDC)		See Part Listing			
Maximum Current (1 second discharge to 1/2 WVDC)		See Part Listing			
Leakage Current (12hrs, 25°C)		See Part Listing			
Life Time at Rated Temperature		10 years			
		Capacitance change ESR Leakage current	<30% of initially measured values <200% of initially measured values < specified maximum value		
Life cycles (25°C) 1 cycle= Charge to WVDC for 20s, constant voltage charging for 10s, discharge to 1/2 WVDC for 20s, rest for 10s		500,000 cycles			
		Capacitance change ESR Leakage current	<30% of initially measured values <200% of initially measured values < specified maximum value		

## PHYSICAL DIMENSIONS

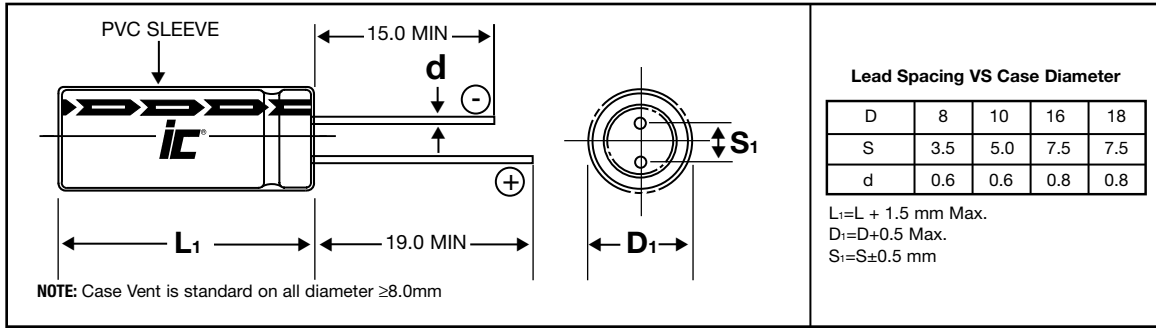

107DCN2R7Q

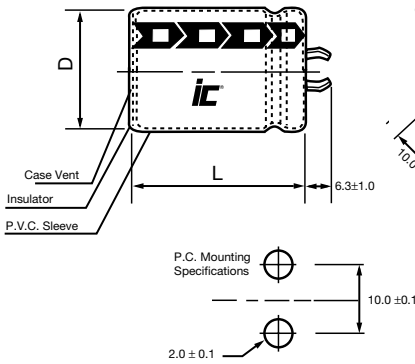

407DCN2R7K

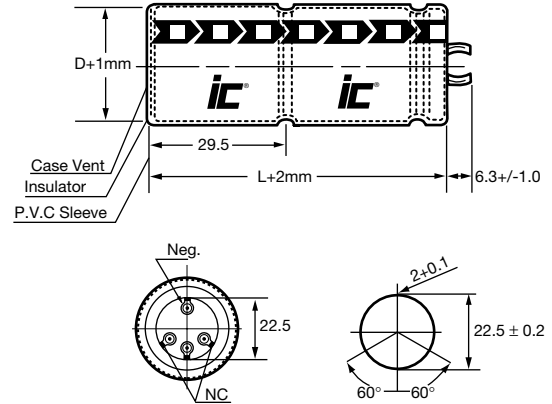

### 5.4 Volt units only

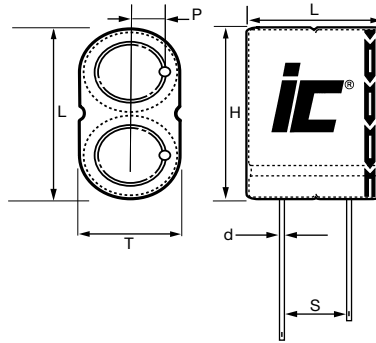

LxHxT (±1.0mm)	S±0.5mm	P±0.5	d
17x23x9	8	2.5	0.6
21x23x10.5	10	5.25	0.6

## STANDARD PARTS LISTING

Capacitance (F)	VDC	IC PART NUMBER	Rated Current (A)	Maximum Current (A)	ESR AC (1kHz) (mΩ)	ESR DC (mΩ)	Max stored energy (J)	LC (mA)	Specific Energy Gravimetric DENSITY (Wh/kg)	Specific Energy Volumetric Density (Wh/l)	Specific power gravimetric (kW/kg)	Specific Power volumetric (kW/l)	Weight (grams)	Volume (mL)	Dimensions DxL LxHxT (mm)
3	2.7	305DCN2R7Q	.764	3.1	75	100	10.935	1	1.47	2.2	12.15	18.23	1.5	1	8x20
5	2.7	505DCN2R7Q	1.3	4.8	60	80	18.225	1.2	2.04	3.19	9.11	14.24	2.5	1.6	10x20
10	2.7	106DCN2R7Q	2.5	9	35	50	36.45	1.4	2.89	4.3	10.41	15.51	3.5	2.35	10x30
25	2.7	256DCN2R7Q	5.9	19.3	20	30	91.13	1.5	3.24	5.04	7.79	12.1	7.8	5.02	16x25
50	2.7	506DCN2R7Q	10.8	30	16	25	182.25	1.6	3.61	4.96	5.21	7.15	14	10.2	18x40
100	2.7	107DCN2R7Q	21.4	58.7	10	13	364.5	1.7	4.5	5.92	6.23	8.2	22.5	17.1	22x45
400	2.7	407DCN2R7K	86	237	3.2	3.2	1485	1.2	6.04	6.75	8.5	9.49	67	60	35x62
1.5	5.4	155DCN5R4Q	.765	3.1	150	200	21.87	1.6	1.74	1.91	10.41	11.39	3.5	3.2	17x23x9
2.5	5.4	255DCN5R4Q	1.3	5.1	100	130	36.45	1.7	2.02	1.87	11.2	10.39	5	5.4	21x23x10.5