

SH7058 E6000H Emulator HS7058EPH62H
SH7058S, SH7059 E6000H Emulator HS7059EPH62H
User's Manual

Renesas Microcomputer Development Environment System
SuperH™ Family / SH7050 Series
HS7058EPH62HE

User's Manual

Rev.1.00
Revision Date: Jun. 30, 2009

Renesas Technology
www.renesas.com

Notes regarding these materials

1. This document is provided for reference purposes only so that Renesas customers may select the appropriate Renesas products for their use. Renesas neither makes warranties or representations with respect to the accuracy or completeness of the information contained in this document nor grants any license to any intellectual property rights or any other rights of Renesas or any third party with respect to the information in this document.
2. Renesas shall have no liability for damages or infringement of any intellectual property or other rights arising out of the use of any information in this document, including, but not limited to, product data, diagrams, charts, programs, algorithms, and application circuit examples.
3. You should not use the products or the technology described in this document for the purpose of military applications such as the development of weapons of mass destruction or for the purpose of any other military use. When exporting the products or technology described herein, you should follow the applicable export control laws and regulations, and procedures required by such laws and regulations.
4. All information included in this document such as product data, diagrams, charts, programs, algorithms, and application circuit examples, is current as of the date this document is issued. Such information, however, is subject to change without any prior notice. Before purchasing or using any Renesas products listed in this document, please confirm the latest product information with a Renesas sales office. Also, please pay regular and careful attention to additional and different information to be disclosed by Renesas such as that disclosed through our website. (<http://www.renesas.com>)
5. Renesas has used reasonable care in compiling the information included in this document, but Renesas assumes no liability whatsoever for any damages incurred as a result of errors or omissions in the information included in this document.
6. When using or otherwise relying on the information in this document, you should evaluate the information in light of the total system before deciding about the applicability of such information to the intended application. Renesas makes no representations, warranties or guarantees regarding the suitability of its products for any particular application and specifically disclaims any liability arising out of the application and use of the information in this document or Renesas products.
7. With the exception of products specified by Renesas as suitable for automobile applications, Renesas products are not designed, manufactured or tested for applications or otherwise in systems the failure or malfunction of which may cause a direct threat to human life or create a risk of human injury or which require especially high quality and reliability such as safety systems, or equipment or systems for transportation and traffic, healthcare, combustion control, aerospace and aeronautics, nuclear power, or undersea communication transmission. If you are considering the use of our products for such purposes, please contact a Renesas sales office beforehand. Renesas shall have no liability for damages arising out of the uses set forth above.
8. Notwithstanding the preceding paragraph, you should not use Renesas products for the purposes listed below:
 - (1) artificial life support devices or systems
 - (2) surgical implantations
 - (3) healthcare intervention (e.g., excision, administration of medication, etc.)
 - (4) any other purposes that pose a direct threat to human lifeRenesas shall have no liability for damages arising out of the uses set forth in the above and purchasers who elect to use Renesas products in any of the foregoing applications shall indemnify and hold harmless Renesas Technology Corp., its affiliated companies and their officers, directors, and employees against any and all damages arising out of such applications.
9. You should use the products described herein within the range specified by Renesas, especially with respect to the maximum rating, operating supply voltage range, movement power voltage range, heat radiation characteristics, installation and other product characteristics. Renesas shall have no liability for malfunctions or damages arising out of the use of Renesas products beyond such specified ranges.
10. Although Renesas endeavors to improve the quality and reliability of its products, IC products have specific characteristics such as the occurrence of failure at a certain rate and malfunctions under certain use conditions. Please be sure to implement safety measures to guard against the possibility of physical injury, and injury or damage caused by fire in the event of the failure of a Renesas product, such as safety design for hardware and software including but not limited to redundancy, fire control and malfunction prevention, appropriate treatment for aging degradation or any other applicable measures. Among others, since the evaluation of microcomputer software alone is very difficult, please evaluate the safety of the final products or system manufactured by you.
11. In case Renesas products listed in this document are detached from the products to which the Renesas products are attached or affixed, the risk of accident such as swallowing by infants and small children is very high. You should implement safety measures so that Renesas products may not be easily detached from your products. Renesas shall have no liability for damages arising out of such detachment.
12. This document may not be reproduced or duplicated, in any form, in whole or in part, without prior written approval from Renesas.
13. Please contact a Renesas sales office if you have any questions regarding the information contained in this document, Renesas semiconductor products, or if you have any other inquiries.

IMPORTANT INFORMATION

READ FIRST

• **READ this user's manual before using this emulator product.**

• **KEEP the user's manual handy for future reference.**

Do not attempt to use the emulator product until you fully understand its mechanism.

Emulator Product:

Throughout this document, the term "emulator product" shall be defined as the following products produced only by Renesas Technology Corp. excluding all subsidiary products.

- Emulator station
- PC interface board
- User system interface board
- Cable

The user system or a host computer is not included in this definition.

Purpose of the Emulator Product:

This emulator product is a software and hardware development tool for systems employing the Renesas microcomputer. This emulator product must only be used for the above purpose.

Limited Applications:

This emulator product is not authorized for use in MEDICAL, atomic energy, aeronautical or space technology applications without consent of the appropriate officer of a Renesas sales company. Such use includes, but is not limited to, use in life support systems. Buyers of this emulator product must notify the relevant Renesas sales offices before planning to use the product in such applications.

Improvement Policy:

Renesas Technology Corp. (including its subsidiaries, hereafter collectively referred to as Renesas) pursues a policy of continuing improvement in design, performance, and safety of the emulator product. Renesas reserves the right to change, wholly or partially, the specifications, design, user's manual, and other documentation at any time without notice.

Target User of the Emulator Product:

This emulator product should only be used by those who have carefully read and thoroughly understood the information and restrictions contained in the user's manual. Do not attempt to use the emulator product until you fully understand its mechanism.

It is highly recommended that first-time users be instructed by users that are well versed in the operation of the emulator product.

LIMITED WARRANTY

Renesas warrants its emulator products to be manufactured in accordance with published specifications and free from defects in material and/or workmanship. Renesas, at its option, will repair or replace any emulator products returned intact to the factory, transportation charges prepaid, which Renesas, upon inspection, determine to be defective in material and/or workmanship. The foregoing shall constitute the sole remedy for any breach of Renesas' warranty. See the Renesas warranty booklet for details on the warranty period. This warranty extends only to you, the original Purchaser. It is not transferable to anyone who subsequently purchases the emulator product from you. Renesas is not liable for any claim made by a third party or made by you for a third party.

DISCLAIMER

RENESAS MAKES NO WARRANTIES, EITHER EXPRESS OR IMPLIED, ORAL OR WRITTEN, EXCEPT AS PROVIDED HEREIN, INCLUDING WITHOUT LIMITATION THEREOF, WARRANTIES AS TO MARKETABILITY, MERCHANTABILITY, FITNESS FOR ANY PARTICULAR PURPOSE OR USE, OR AGAINST INFRINGEMENT OF ANY PATENT. IN NO EVENT SHALL RENESAS BE LIABLE FOR ANY DIRECT, INCIDENTAL OR CONSEQUENTIAL DAMAGES OF ANY NATURE, OR LOSSES OR EXPENSES RESULTING FROM ANY DEFECTIVE EMULATOR PRODUCT, THE USE OF ANY EMULATOR PRODUCT, OR ITS DOCUMENTATION, EVEN IF ADVISED OF THE POSSIBILITY OF SUCH DAMAGES. EXCEPT AS EXPRESSLY STATED OTHERWISE IN THIS WARRANTY, THIS EMULATOR PRODUCT IS SOLD "AS IS", AND YOU MUST ASSUME ALL RISK FOR THE USE AND RESULTS OBTAINED FROM THE EMULATOR PRODUCT.

State Law:

Some states do not allow the exclusion or limitation of implied warranties or liability for incidental or consequential damages, so the above limitation or exclusion may not apply to you. This warranty gives you specific legal rights, and you may have other rights which may vary from state to state.

The Warranty is Void in the Following Cases:

Renesas shall have no liability or legal responsibility for any problems caused by misuse, abuse, misapplication, neglect, improper handling, installation, repair or modifications of the emulator product without Renesas' prior written consent or any problems caused by the user system.

All Rights Reserved:

This user's manual and emulator product are copyrighted and all rights are reserved by Renesas. No part of this user's manual, all or part, may be reproduced or duplicated in any form, in hard-copy or machine-readable form, by any means available without Renesas' prior written consent.

Other Important Things to Keep in Mind:

1. Circuitry and other examples described herein are meant merely to indicate the characteristics and performance of Renesas' semiconductor products. Renesas assumes no responsibility for any intellectual property claims or other problems that may result from applications based on the examples described herein.
2. No license is granted by implication or otherwise under any patents or other rights of any third party or Renesas.

Figures:

Some figures in this user's manual may show items different from your actual system.

Limited Anticipation of Danger:

Renesas cannot anticipate every possible circumstance that might involve a potential hazard. The warnings in this user's manual and on the emulator product are therefore not all inclusive. Therefore, you must use the emulator product safely at your own risk.

SAFETY PAGE

READ FIRST

- **READ** this user's manual before using this emulator product.
 - **KEEP** the user's manual handy for future reference.
- Do not attempt to use the emulator product until you fully understand its mechanism.

DEFINITION OF SIGNAL WORDS



This is the safety alert symbol. It is used to alert you to potential personal injury hazards. Obey all safety messages that follow this symbol to avoid possible injury or death.

DANGER

DANGER indicates an imminently hazardous situation which, if not avoided, will result in death or serious injury.

WARNING

WARNING indicates a potentially hazardous situation which, if not avoided, could result in death or serious injury.

CAUTION

CAUTION indicates a potentially hazardous situation which, if not avoided, may result in minor or moderate injury.

CAUTION

CAUTION used without the safety alert symbol indicates a potentially hazardous situation which, if not avoided, may result in property damage.

NOTE emphasizes essential information.

WARNING

Observe the precautions listed below. Failure to do so will result in a **FIRE HAZARD** and will damage the user system and the emulator product or will result in **PERSONAL INJURY**. The **USER PROGRAM** will be **LOST**.

1. Carefully handle the emulator product to prevent receiving an electric shock because the emulator product has a DC power supply. Do not repair or remodel the emulator product by yourself for electric shock prevention and quality assurance.
2. Always switch **OFF** the emulator and user system before connecting or disconnecting any **CABLES** or **PARTS**.
3. Always before connecting, make sure that pin 1 on both sides are correctly aligned.
4. Supply power according to the power specifications and do not apply an incorrect power voltage. Use only the provided AC power cable. Use only the specified type of fuse.

Warnings on Emulator Usage

Warnings described below apply as long as you use this emulator. Be sure to read and understand the warnings below before using this emulator. Note that these are the main warnings, not the complete list.

WARNING

Always switch OFF the emulator and user system before connecting or disconnecting any CABLES or PARTS. Failure to do so will result in a FIRE HAZARD and will damage the user system and the emulator product or will result in PERSONAL INJURY. The USER PROGRAM will be LOST.

CAUTION

Place the emulator station and evaluation chip board so that the trace cables are not bent or twisted. A bent or twisted cable will impose stress on the user interface leading to connection or contact failure. Make sure that the emulator station is placed in a secure position so that it does not move during use nor impose stress on the user interface.

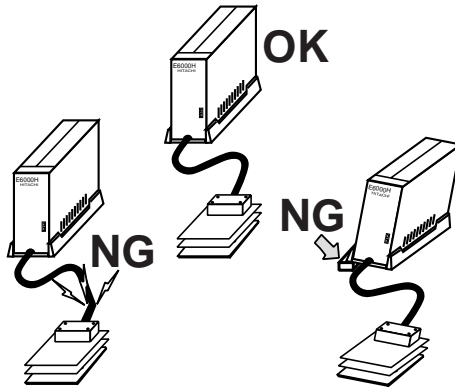

CAUTION

This equipment has been tested and found to comply with the limits for a Class A digital device, pursuant to part 15 of the FCC Rules. These limits are designed to provide reasonable protection against harmful interference when the equipment is operated in a commercial environment. This equipment generates, uses, and can radiate radio frequency energy and, if not installed and used in accordance with the instruction manual, may cause harmful interference to radio communications. Operation of this equipment in a residential area is likely to cause harmful interference in which case the user will be required to correct the interference at his own expense.

Compatibility with the Former Products:

The HS7058EPH62H and HS7059EPH62H are the successor devices for the HS7058EPH60H and HS7059EPH60H (legacy devices). The connector for the user system on the EV-chip board has been modified, in such a way that the user system interface board cannot be used. Separate purchase of a special user system interface board will be required.

Preface

Thank you for purchasing the E6000H emulator.

CAUTION

Read this manual before using the emulator product. Incorrect operation or connection will damage the user system, the emulator product, and the user program.

The E6000H emulator is an efficient software and hardware development support tool for application systems using the microcomputer developed by Renesas Technology Corp.

The E6000H emulator can either be used without a user system, for developing and debugging software, or connected via a user system interface cable to a user system, for debugging user hardware.

The emulator provides the following features:

1. Realtime emulation of the MCU
2. Efficient debugging enabled by variable break functions and a mass-storage trace memory (128-kcycles)
3. Parallel access with a command execution during emulation, for example
 - Trace data display
 - Emulation memory display and modification
4. Performance analysis
 - Measurement of subroutine execution time and count for evaluating the execution efficiency of user programs
5. Graphical User Interface by the High-performance Embedded Workshop that runs on Windows[®] operating systems

High-performance Embedded Workshop is a Graphical User Interface intended to ease the development and debugging of applications written in C/C++ programming language and assembly language. Its aim is to provide a powerful yet intuitive way of accessing, observing and modifying the debugging platform in which the application is running.

High-performance Embedded Workshop is a powerful development environment for embedded applications targeted at microcontrollers. The main features are:

- A configurable build engine that allows you to set-up compiler, assembler and linker options via an easy to use interface.
- An integrated text editor with user customizable syntax coloring to improve code readability.
- A configurable environment to run your own tools.
- An integrated debugger which allows you to build and debug in the same application.
- Version control support.

The High-performance Embedded Workshop has been designed with two key aims; firstly to provide you, the user, with a set of powerful development tools and, secondly, to unify and present them in a way that is easy to use.

About This Manual

This manual is comprised of two parts: Hardware Part and Debugger Part.

Hardware Part: Preparation before use, hardware specifications, and troubleshooting procedure.

Debugger Part: A peculiar debugging function to the emulator, tutorial, Emulator software specification, and notes.

This manual describes the debugging function for SH7058 E6000H Emulator debugger that used with the High-performance Embedded Workshop.

For detailed information on the basic “look and feel” of the High-performance Embedded Workshop and customizing the High-performance Embedded Workshop environment and the build and the debugging functions common to the High-performance Embedded Workshop products, refer to the High-performance Embedded Workshop user's manual.

This manual does not intend to explain how to write C/C++ or assembly language programs, how to use any particular operating system or how best to tailor code for the individual devices. These issues are left to the respective manuals.

Microsoft, MS-DOS, Windows, Windows NT are registered trademarks of Microsoft Corporation.

Visual SourceSafe is a trademark of Microsoft Corporation.

IBM is a registered trademark of International Business Machines Corporation.

All brand or product names used in this manual are trademarks or registered trademarks of their respective companies or organizations.

Document Conventions

This manual uses the following typographic conventions:

Table 1 Typographic Conventions

Convention	Meaning
[Menu->Menu Option]	Bold text with ‘->’ is used to indicate menu options (for example, [File->Save As...]).
FILENAME.C	Uppercase names are used to indicate filenames.
“enter this string”	Used to indicate text that must be entered (excluding the “” quotes).
Key + Key	Used to indicate required key presses. For example, CTRL+N means press the CTRL key and then, whilst holding the CTRL key down, press the N key.
☞ (The “how to” symbol)	When this symbol is used, it is always located in the left-hand margin. It indicates that the text to its immediate right is describing “how to” do something.

Components

Check all the components described in the component list unpacking. If the components are not complete, contact a Renesas sales office.

Contents

Hardware Part	1
Section 1 Overview	1
1.1 Notes on Usage	1
1.2 Emulator Hardware Components	2
1.2.1 E6000H Station Components (A Part of Photos may be Different from Real Appearances)	3
1.2.2 Evaluation Chip Board Configuration	5
1.2.3 Configuration of User System Interface Board	6
1.3 System Configuration	7
1.3.1 System Configuration Using a PC Interface Board	7
Section 2 Preparation before Use	9
2.1 Description on Emulator Usage	9
2.2 Emulator Connection	10
2.2.1 Connecting the User System	10
2.2.2 Connecting the User System Interface Board	11
2.2.3 Connecting the External Probe	12
2.2.4 Selecting the Clock	13
2.2.5 Connecting the System Ground	15
2.2.6 PC Interface Board Specifications	16
Section 3 Hardware Specifications	17
3.1 Environmental Conditions	17
3.2 Emulator External Dimensions and Mass	18
3.3 User System Interface Circuit	19
3.3.1 User System Interface Circuit	19
3.3.2 Delay Time with the User System Interface	26
3.4 Connecting the Emulator to the User System	26
3.4.1 Connecting to the User System	26
3.4.2 Pin Assignment on the User System Interface Connector	35
3.4.3 Precautions on Connecting the User System	45
3.5 Support of the Target MCU	46
3.5.1 Memory Space	46
3.5.2 Low Power-Consumption Mode (Sleep, Software Standby, and Hardware Standby)	47
3.5.3 Interrupts	47
3.5.4 Control Input Signals (_RES, _BREQ, and _WAIT)	47
3.5.5 Watchdog Timer (WDT)	47
3.5.6 A/D Converter	48
3.5.7 Emulator State and On-Chip Modules	48
3.5.8 Different Initial Values of Registers in the Emulator	49
Section 4 Diagnostic Test Procedure	51
4.1 System Set-Up for Diagnostic Program Execution	51
4.2 Test Item of the Diagnostic Program	53
4.3 Diagnostic Test Procedure Using the Diagnostic Program	54
4.4 Repair Request Sheet	58

Debugger Part	49
Section 1 Overview	1
Section 2 Preparation before Use	3
2.1 Method for Activating High-performance Embedded Workshop	3
2.1.1 Creating a New Workspace (Toolchain Not Used)	4
2.1.2 Creating a New Workspace (Toolchain Used)	8
2.1.3 Selecting an Existing Workspace	12
2.2 Connecting the Emulator	13
2.3 Re-connecting the Emulator	14
2.4 Ending the Emulator	14
Section 3 Debugging	15
3.1 Setting the Environment for Emulation	15
3.1.1 Opening the [Configuration Properties] Dialog Box	15
3.1.2 Using the Emulation RAM	18
3.1.3 Selecting the Interface to be Connected	20
3.2 Downloading a Program	21
3.2.1 Downloading a Program	21
3.2.2 Viewing the Source Code	21
3.2.3 Viewing the Assembly-Language Code	24
3.2.4 Modifying the Assembly-Language Code	25
3.2.5 Viewing a Specific Address	25
3.2.6 Viewing the Current Program Counter Address	25
3.3 Viewing the Current Status	26
3.4 Reading and Displaying the Emulator Information Regularly	27
3.4.1 Opening the [Extended Monitor] Window	27
3.4.2 Selecting Items to be Displayed	28
3.5 Displaying Memory Contents in Realtime	29
3.5.1 Opening the [Monitor] Window	29
3.5.2 Changing the Monitor Settings	31
3.5.3 Temporarily Stopping Update of the Monitor	31
3.5.4 Deleting the Monitor Settings	31
3.5.5 Monitoring Variables	31
3.5.6 Hiding the [Monitor] Window	32
3.5.7 Managing the [Monitor] Window	33
3.6 Looking at Variables	34
3.6.1 [Watch] Window	34
3.7 Using the Event Points	36
3.7.1 Setting a Software Breakpoint	37
3.7.2 Setting an On-Chip Breakpoint	39
3.7.3 Settings an On-Emulator Breakpoint	42
3.7.4 Editing Event Points	45
3.7.5 Modifying Event Points	45
3.7.6 Enabling an Event Point	45
3.7.7 Disabling an Event Point	45
3.7.8 Deleting an Event Point	45
3.7.9 Deleting All Event Points	45
3.7.10 Viewing the Source Line for an Event Point	45
3.8 Viewing the Trace Information	46
3.8.1 Opening the [Trace] Window	46
3.8.2 Acquiring Trace Information	46

3.8.3	Specifying Trace Acquisition Conditions	48
3.8.4	Searching for a Trace Record.....	55
3.8.5	Clearing the Trace Information.....	56
3.8.6	Saving the Trace Information in a File.....	57
3.8.7	Viewing the [Editor] Window.....	57
3.8.8	Trimming the Source	57
3.8.9	Temporarily Stopping Trace Acquisition.....	57
3.8.10	Restarting Trace Acquisition.....	57
3.8.11	Extracting Records from the Acquired Information	58
3.8.12	Calculating the Difference in Time Stamping.....	60
3.8.13	Analyzing Statistical Information	61
3.8.14	Extracting Function Calls from the Acquired Trace Information.....	62
3.9	Analyzing Performance	63
3.9.1	Opening the [Performance Analysis] Window.....	65
3.9.2	Setting Conditions for Measurement.....	66
3.9.3	Starting Performance Data Acquisition.....	73
3.9.4	Deleting a Measurement Condition.....	73
3.9.5	Deleting All Measurement Conditions.....	73
3.10	Profiling Function.....	74
3.10.1	Enabling the Profile	74
3.10.2	Specifying Measuring Mode.....	74
3.10.3	Executing the Program and Checking the Results.....	74
3.10.4	[List] Sheet	75
3.10.5	[Tree] Sheet	76
3.11	[Profile-Chart] Window.....	78
Section 4 Tutorial.....		81
4.1	Introduction	81
4.2	Running the High-performance Embedded Workshop	82
4.3	Downloading the Tutorial Program.....	83
4.3.1	Downloading the Tutorial Program.....	83
4.3.2	Displaying the Source Program	84
4.4	Setting a Software Breakpoint	85
4.5	Setting Registers	86
4.6	Executing the Program.....	87
4.7	Reviewing Breakpoints.....	90
4.8	Referring to Symbols.....	91
4.9	Viewing Memory.....	92
4.10	Watching Variables.....	93
4.11	Displaying Local Variables.....	96
4.12	Stepping Through a Program.....	97
4.12.1	Executing the [Step In] Command	97
4.12.2	Executing the [Step Out] Command	99
4.12.3	Executing the [Step Over] Command	100
4.13	Forced Breaking of Program Executions	101
4.14	Resetting the Target MCU	101
4.15	Break Function	102
4.15.1	Software Break Function	102
4.15.2	On-Chip Break Function.....	108
4.16	Trace Functions	110
4.16.1	Displaying Trace Information by the Free Trace Function.....	111
4.16.2	Displaying Trace Information by the Trace Stop Function	113
4.16.3	Displaying Trace Information by the Conditional Trace Function.....	116

4.16.4	Statistics.....	117
4.16.5	Function Calls.....	121
4.17	Stack Trace Function	122
4.18	Performance Analysis Function	124
4.18.1	Time Of Specified Range Measurement	124
4.19	Profiling Function.....	127
4.20	Monitor Function.....	133
4.21	What Next?.....	135
Section 5 Software Specifications and Notes Specific to This Product		137
5.1	Supported Hardware	137
5.2	Debugging Platform.....	137
5.3	Displaying and Modifying the Contents of Memory.....	137
5.3.1	Reference Values for Parallel Access Function Termination Period.....	138
5.3.2	Monitor Function	139
5.3.4	Note on Accessing Memory.....	139
5.4	Executing Your Program	139
5.4.1	Step Execution.....	139
5.4.2	Break Suspension.....	139
5.5	Event Functions	140
5.5.1	Software Breakpoints.....	140
5.5.2	On-Chip Break.....	140
5.5.3	On-Emulator Break	141
5.6	Trace Functions	142
5.6.1	Displaying the Trace Information	142
5.6.2	Specifying Trace Acquisition Conditions	142
5.6.3	Searching for a Trace Record.....	142
5.6.4	Filtering Trace Records.....	142
5.7	Monitor Function.....	143
5.8	Performance Analysis Function	143
5.8.1	Errors.....	143
5.8.2	Notes.....	143
5.9	Profiling Function.....	144
5.10	Input Format	145
5.10.1	Entering Masks	145
5.11	Downloading a Program.....	145
5.12	Tutorial Program.....	146
5.12.1	Downloading the Tutorial Program.....	146
5.12.2	Notes on Operating the Tutorial Program	146
Section 6 Error Messages		147
6.1	Error Messages of the Emulator.....	147
6.1.1	Error Messages at Emulator Initiation.....	147
6.1.2	Error Messages during Emulation.....	149
Appendix A Menus.....		151
Appendix B Command Lines		155

Hardware Part

Section 1 Overview

1.1 Notes on Usage

CAUTION

READ the following warnings before using the emulator product. Incorrect operation will damage the user system and the emulator product. The USER PROGRAM will be LOST.

1. Check all components with the component list after unpacking the emulator.
2. Never place heavy objects on the casing.
3. Observe the following conditions in the area where the emulator is to be used:
 - Make sure that the internal cooling fans on the sides of the emulator must be at least 20 cm (8") away from walls or other equipment.
 - Keep out of direct sunlight or heat. Refer to section 3.1, Environmental Conditions.
 - Use in an environment with constant temperature and humidity.
 - Protect the emulator from dust.
 - Avoid subjecting the emulator to excessive vibration. Refer to section 3.1, Environmental Conditions.
4. Protect the emulator from excessive impacts and stresses.
5. Before using the emulator's power supply, check its specifications such as power voltage and frequency.
6. When moving the emulator, take care not to vibrate or otherwise damage it.
7. After connecting the cable, check that it is connected correctly. For details, refer to section 2, Preparation before Use.
8. Supply power to the emulator and connected parts after connecting all cables. Cables must not be connected or removed while the power is on.
9. For details on differences between the target MCU and the emulator, refer to section 3.5, Support of the Target MCU.

1.2 Emulator Hardware Components

The emulator consists of an E6000H station and an evaluation chip board. By installing a user system interface board (option) on your host computer, the emulator can be connected in the same package as the device. PC interface (option) includes a PC interface board (PCI bus and PC card bus), a LAN adapter (connected with the network), and a USB adapter (connected with the USB interface). By connecting the emulator to the host computer via those interfaces, the High-performance Embedded Workshop can be used for debugging. For details on PC interface boards (available for PCI bus and PC card bus specifications), LAN adapter, and USB adapter, refer to their description notes.

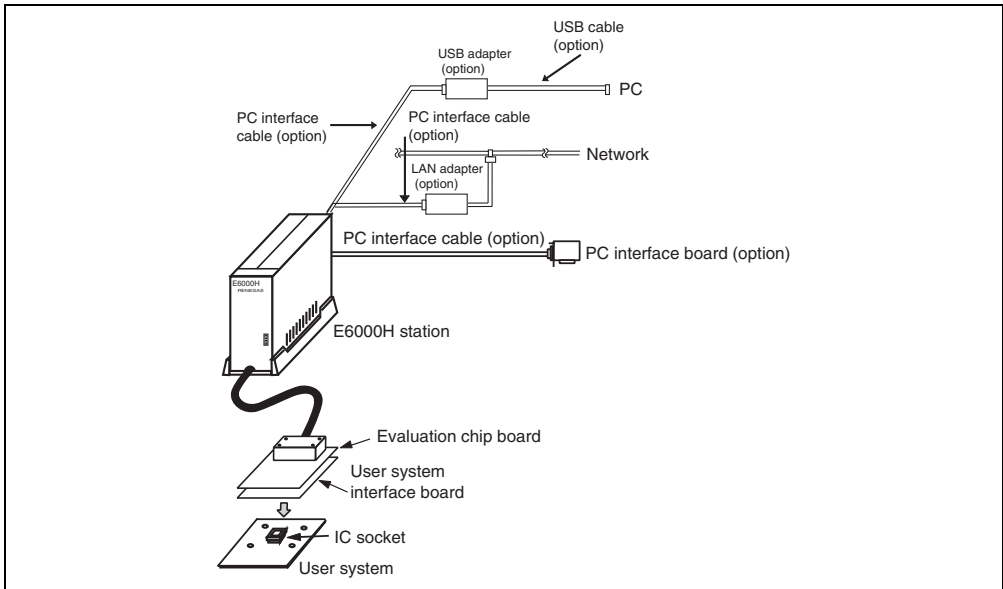

Figure 1.1 Emulator Hardware Components

1.2.1 E6000H Station Components (A Part of Photos may be Different from Real Appearances)

The names of the components on the front/rear panel of the E6000H station are listed below.

Front Panel:



Figure 1.2 E6000H Station: Front Panel

- (a) POWER lamp: Is lit up while the E6000H station is supplied with power.
(b) RUN lamp: Is lit up while the user program is running.

Rear Panel:**Figure 1.3 E6000H Station: Rear Panel**

- (a) Power switch: Turning this switch to I (input) supplies power to the emulator (E6000H station and evaluation chip board).
- (b) AC power connector: For an AC 100-V to 240-V power supply.
- (c) PC interface cable connector: For the PC interface cable that connects the host computer to the E6000H station. A PC interface board, PC card interface, LAN adapter, or USB adapter can be connected. Marked PC/IF.

1.2.2 Evaluation Chip Board Configuration

The names of the components on the evaluation chip board of the emulator are listed below.

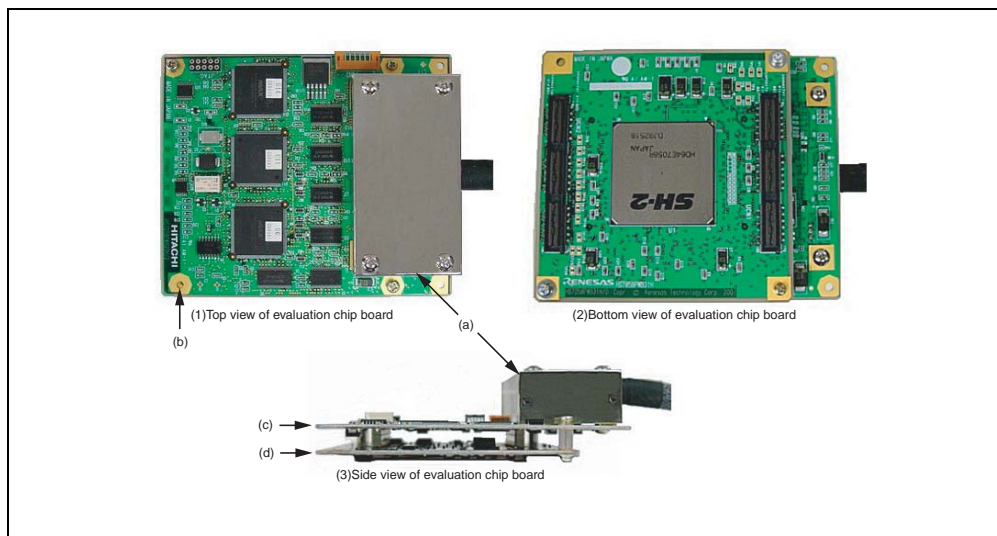

Figure 1.4 Evaluation Chip Board

- (a) Station to evaluation chip board interface connector cover: This is a cover for protecting the connector that connects the E6000H station to the evaluation chip board.
- (b) Crystal oscillator terminals: For installing a crystal oscillator to be used as an external clock source for the target MCU.
- (c) HS7058PWB20H board or HS7059PWB20H board: The board has a connector for the trace cable (figure 1.4 shows the HS7058PWB20H board).
- (d) HS7058PWB31H board or HS7059PWB31H board: An evaluation chip is installed on the board, which has a dedicated connector for the user system interface board or user system (figure 1.4 shows the HS7058PWB31H board).
- (e) User system interface board connector: For connecting the user system interface board or user system.

Note: (a) to (e) listed above are referred to as the evaluation chip board.

1.2.3 Configuration of User System Interface Board

The names of the components of the user system interface board are given below.

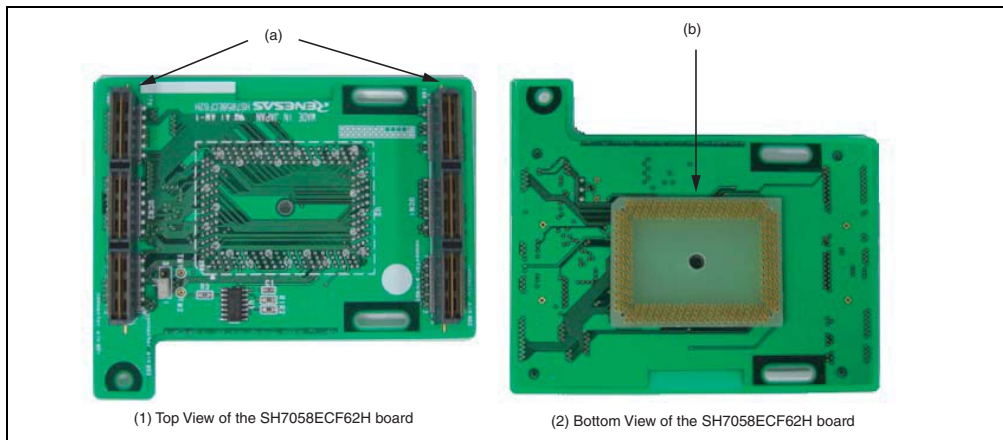

Figure 1.5 Configuration of User System Interface Board

- (a) Connector for the evaluation chip board: For connection to the evaluation chip board.
- (b) Connector for the user system: For connection to the user system.

Figure 1.5 shows the HS7058ECF62H as an example; although the external appearance of this board differs from that of the HS7058ECB62H, the labels for the individual parts are the same.

1.3 System Configuration

The emulator must be connected to a host computer (via the selected PC interface board).

1.3.1 System Configuration Using a PC Interface Board

The emulator can be connected to a host computer via a PC interface board (option: PCI bus or PC card bus). Install the PC interface board to the expansion slot for the interface board in the host computer, and connect the interface cable supplied with the PC interface board to the emulator. A LAN adapter can be used to connect the emulator to a host computer as a network. A USB adapter can be used to connect the emulator to a host computer with the USB interface. For details on PC interface boards (available for PCI bus and PC card bus specifications), LAN adapter, and USB adapter, refer to their description notes. Figure 1.6 shows the configuration of a system in which the PC interface board is used. Figure 1.7 shows the configuration of a system in which the LAN adapter is used. Figure 1.8 shows the configuration of a system in which the USB adapter is used.

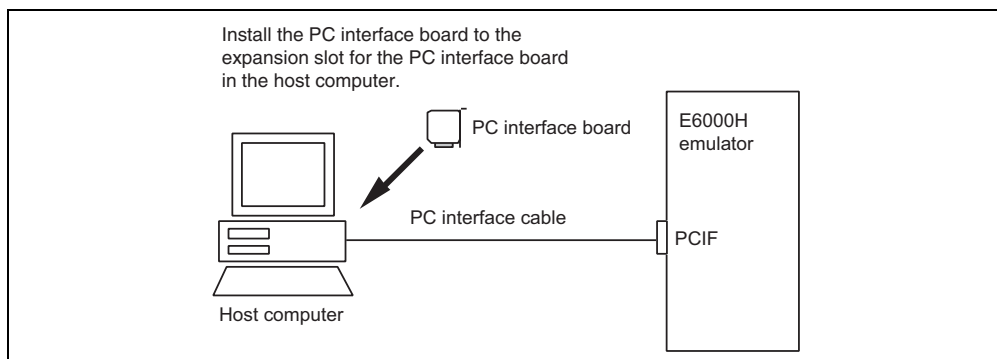

Figure 1.6 System Configuration Using a PC Interface Board

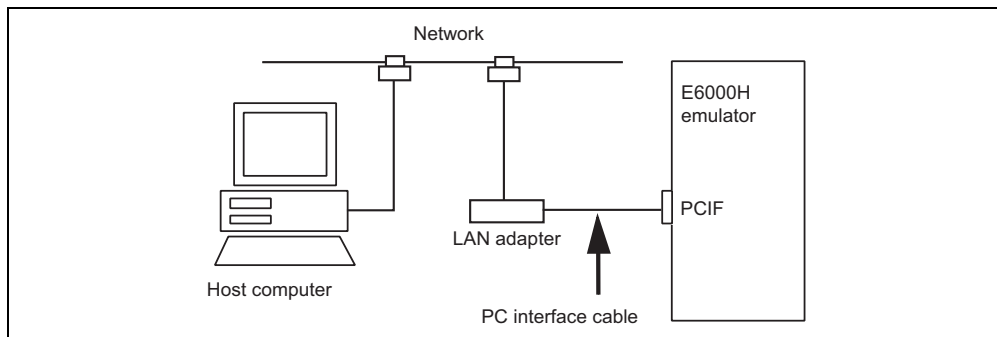

Figure 1.7 System Configuration Using a LAN Adapter

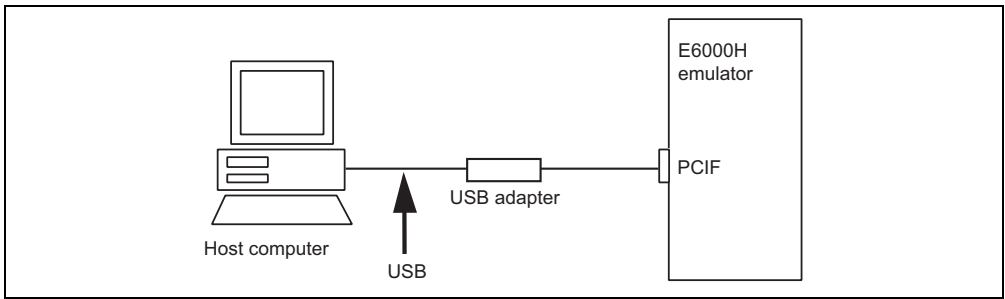

Figure 1.8 System Configuration Using a USB Adapter

Section 2 Preparation before Use

2.1 Description on Emulator Usage

This section describes the preparation before use of the emulator. Figure 2.1 is a flowchart on preparation before debugging with the emulator.

CAUTION

Read this section and understand its contents before preparation. Incorrect operation will damage the user system and the emulator. The USER PROGRAM will be LOST.

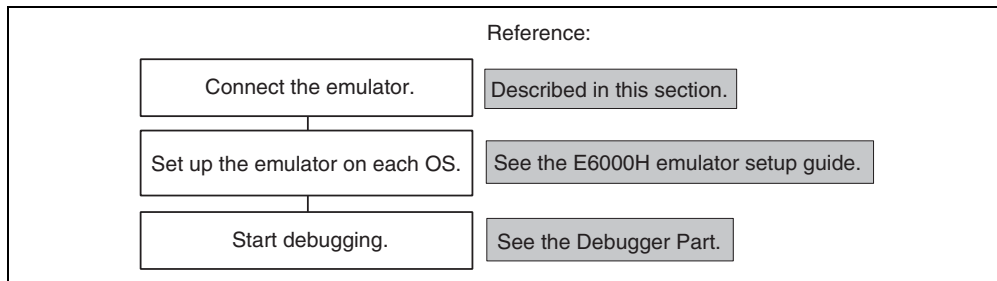

Figure 2.1 Emulator Preparation Flowchart

2.2 Emulator Connection

2.2.1 Connecting the User System

WARNING

Always switch OFF the emulator and user system before connecting or disconnecting any CABLES. Failure to do so will result in a FIRE HAZARD and will damage the user system and the emulator or will result in PERSONAL INJURY. The USER PROGRAM will be LOST.

1. Check that the emulator power switch is turned off. Ensure that the power lamp on the right side of the E6000H station's front panel is not lit.
2. Remove the AC power cable of the E6000H station from the outlet (if the cable is connected to the outlet).
3. Connect pin 1 on the user system connector to the connector installed at the bottom of the E6000H user system interface board. When connecting the connector, prevent the upper or lower side of the board from lifting off the connector. Alternately tighten the screws on both sides of the board.

2.2.2 Connecting the User System Interface Board

WARNING

Always switch OFF the emulator and user system and check pin numbers on the connectors and IC socket before connecting or disconnecting the USER SYSTEM INTERFACE BOARD. Connection with the power on or incorrect connection will damage the emulator, user system interface board, and user system, and result in a FIRE HAZARD.

For details on the method of connecting the user system interface board, refer to the descriptions of the user system interface boards for individual SH7058 E6000H-series products.

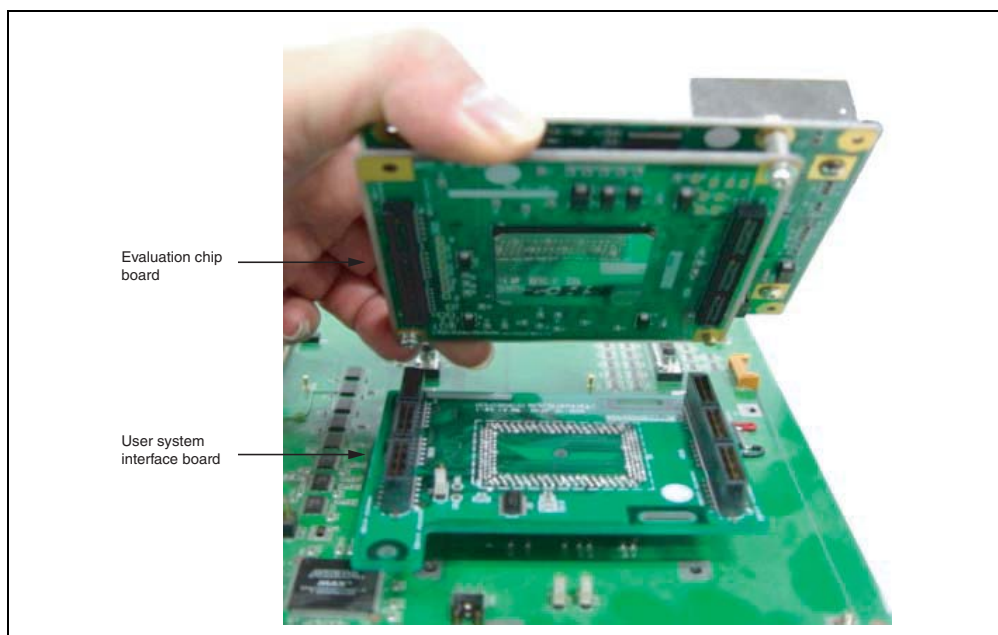

Figure 2.2 Connecting the User System Interface Board

2.2.3 Connecting the External Probe

CAUTION

Check the external probe direction and connect the external probe to the emulator station correctly. Incorrect connection will damage the probe or connector.

When an external probe is connected to the external probe connector on the E6000H evaluation chip board, it enables external signal tracing and multibreak detection. Figure 2.3 shows the external probe connector.

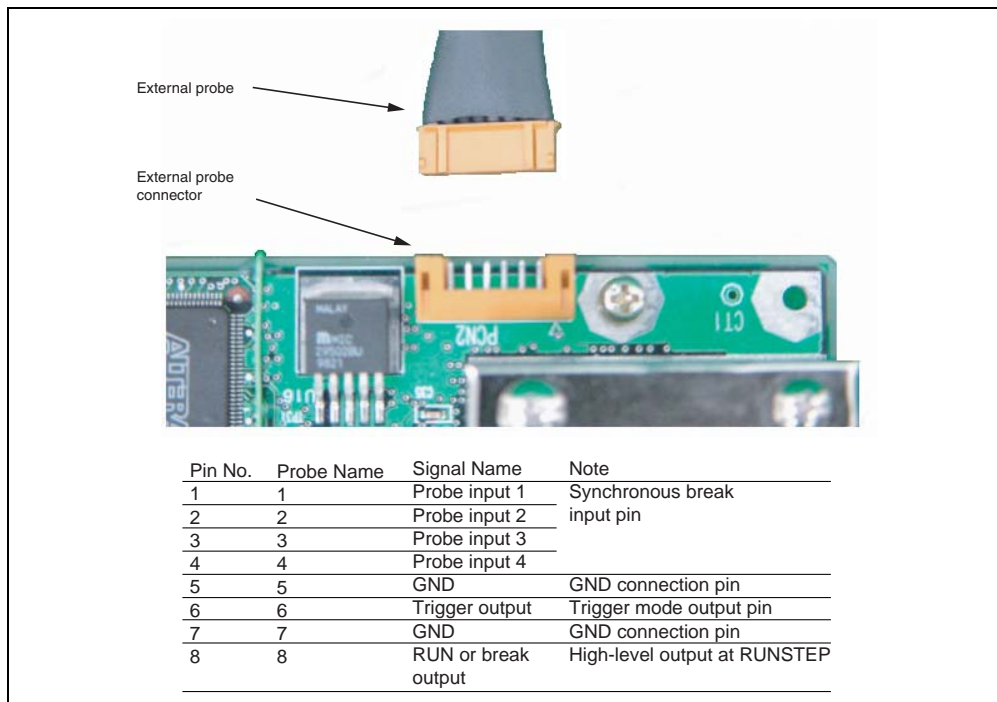

Figure 2.3 External Probe Connector

2.2.4 Selecting the Clock

This emulator supports three types of clock for the target MCU: a crystal oscillator attached on the evaluation chip board, external clock input from the user system, and the emulator internal clock. The clock is specified with the [Configuration Properties] dialog box.

This emulator can use a clock source (ϕ) running at up to 80.0 MHz (eight times the external clock frequency of 10.0 MHz) as the MCU clock input. Select one of the followings:

Target	External clock (clock signal supplied from the user system to the EXTAL pin): 5.0 to 10.0 MHz
Xtal	Crystal oscillator: 5.0 to 10.0 MHz
10 MHz	Emulator internal clock
5 MHz	Emulator internal clock

Crystal Oscillator: A crystal oscillator is not supplied with the emulator. Prepare and use one that has the same frequency as that of the user system. When using a crystal oscillator as the target MCU clock source, the frequency range must be from 5.0 to 10.0 MHz.

CAUTION

Always switch OFF the emulator and user system before connecting or disconnecting the CRYSTAL OSCILLATOR. Otherwise, the USER PROGRAM will be LOST.

Follow the procedure listed below to install the crystal oscillator:

1. Check that the emulator power switch is turned off. (Check that the power LED is not lit.)
2. Attach the crystal oscillator into the terminals on the evaluation chip board (figure 2.4).
3. Turn on the user system power and then the emulator power. Then the crystal oscillator will be automatically set. This function will allow the execution of the user program at the operating frequency of the user system even when the user system is not connected to the emulator.

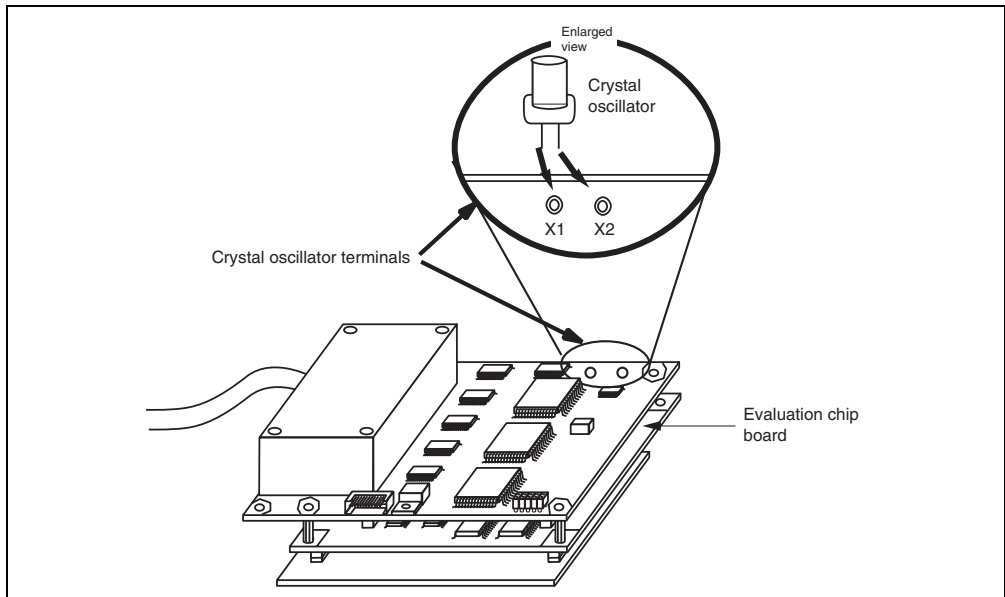

Figure 2.4 Installing the Crystal Oscillator

External Clock: Follow the procedure listed below to select the external clock.

1. Check that the emulator power switch is turned off. (Check that the power LED is not lit.)
2. Connect the evaluation chip board to the user system and supply a clock through the EXTAL pin from the user system.
3. Turn on the user system power and then the emulator power. The external clock will then be automatically set.

Emulator Internal Clock: Specify an emulator internal clock in the [Configuration Properties] dialog box.

Reference:

When the emulator system program is initiated, the emulator automatically selects the MCU clock source according to the following priority:

1. User system's clock when an external clock is supplied from the user system
2. Crystal oscillator when attached to the evaluation chip board
3. Emulator internal clock

2.2.5 Connecting the System Ground

CAUTION

Separate the frame ground from the signal ground at the user system. When the frame ground is connected to the signal ground and the emulator is then connected to the user system, the emulator will malfunction.

The emulator's signal ground is connected to the user system's signal ground via the evaluation chip board. In the E6000H station, the signal ground and frame ground are connected (figure 2.5). At the user system, connect the frame ground only; do not connect the signal ground to the frame ground.

If it is difficult to separate the frame ground from the signal ground in the user system, ground the frame to the same outlet as the 100-V to 240-V power supply of the emulator station (figure 2.6) so that the ground potentials become even.

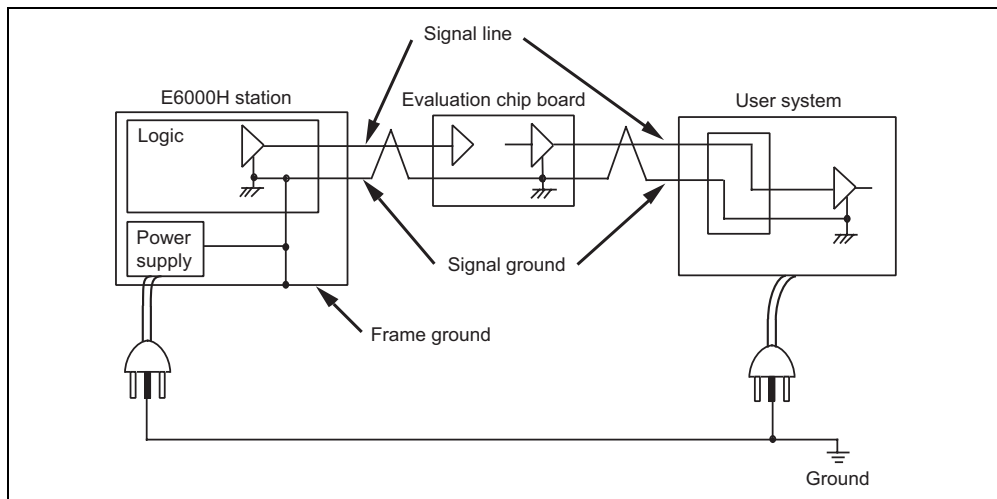

Figure 2.5 Connecting the System Ground

! WARNING

Always switch OFF the emulator and user system before connecting or disconnecting any CABLES. Failure to do so will result in a FIRE HAZARD and will damage the user system and the emulator or will result in PERSONAL INJURY. The USER PROGRAM will be LOST.

The user system must be connected to an appropriate ground so as to minimize noise and the adverse effects of ground loops. When connecting the evaluation chip board and the user system, confirm that the ground pins of the evaluation chip board are firmly connected to the user system's ground.

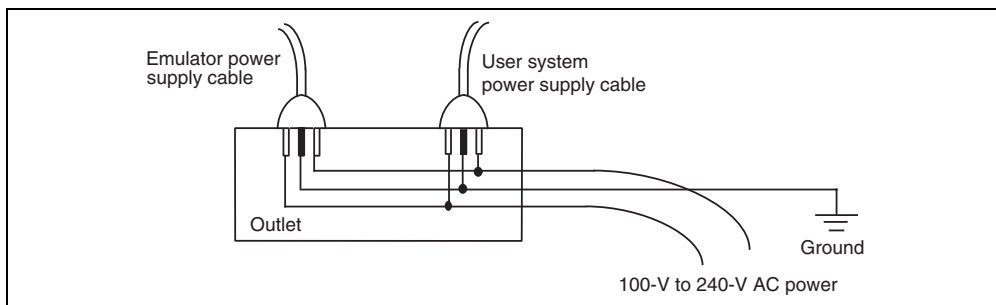

Figure 2.6 Connecting the Frame Ground

2.2.6 PC Interface Board Specifications

For details on the PC interface board, LAN adapter, or USB adapter, refer to their description notes.

Section 3 Hardware Specifications

3.1 Environmental Conditions

CAUTION

Observe the conditions listed in table 3.1 when using the emulator. The following environmental conditions must be satisfied, otherwise the user system and the emulator will not operate normally. The USER PROGRAM will be LOST.

Table 3.1 Environmental Conditions

Item	Specifications
Temperature	Operating: +10 to +35°C
	Storage: -10 to +50°C
Humidity	Operating: 35 to 80% RH, no condensation
	Storage: 35 to 80% RH, no condensation
Vibration	Operating: 2.45 m/s ² max.
	Storage: 4.9 m/s ² max.
	Transportation: 14.7 m/s ² max.
AC input power	Voltage: 100 V to 240 V AC
	Frequency: 50/60 Hz
	Power consumption: 75 W
Ambient gases	There must be no corrosive gases present.

3.2 Emulator External Dimensions and Mass

Figure 3.1 shows the external dimensions and mass of the E6000H emulator (External dimensions are common to the HS7058EPH62H and HS7059EPH62H).

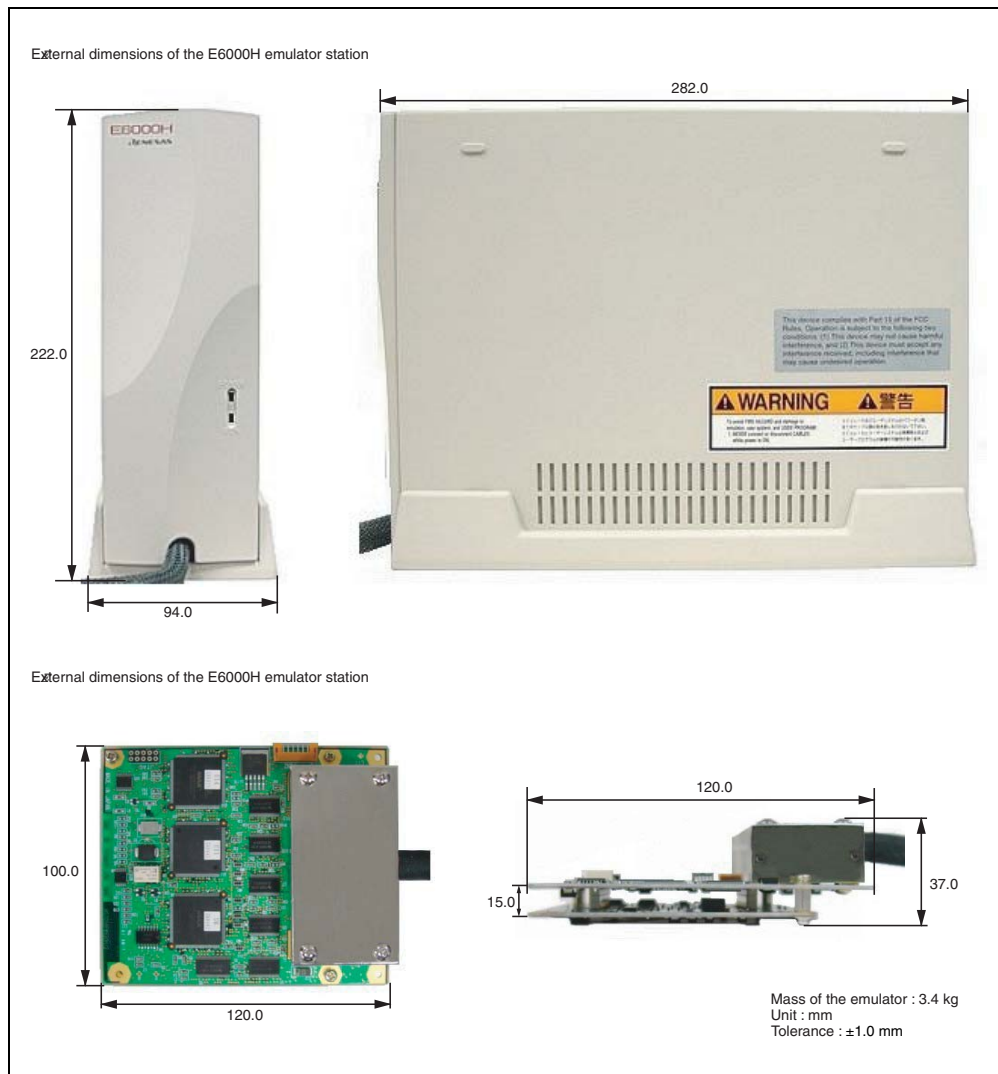

Figure 3.1 External Dimensions and Mass of the Emulator

3.3 User System Interface Circuit

3.3.1 User System Interface Circuit

The circuits that interface the MCU in the emulator to the user system include buffers and resistors. When connecting the emulator to a user system, adjust the user system hardware compensating for FANIN, FANOUT, and propagation delays.

The AC timing values when using the emulator are shown in table 3.2.

Note: The values with the emulator connected, in table 3.2, are measurements for reference and are not guaranteed values.

Table 3.2 Bus Timing when Using the Emulator (Bus Clock: 20.0 MHz)

Item	MCU Specifications (ns)		Values with Emulator Connected (ns)	
	Min	Max	Min	Max
tRDS	15	—	18	—
tACC	$t_{cyc} \times (n + 1.5) - 39$ (n is the number of waits)	—	$t_{cyc} \times (n + 1.5) - 45$ (n is the number of waits)	—

The basic bus cycle (software wait) is shown in figure 3.2. The user system interface circuits connected to the user system are shown in figures 3.3 to 3.8.

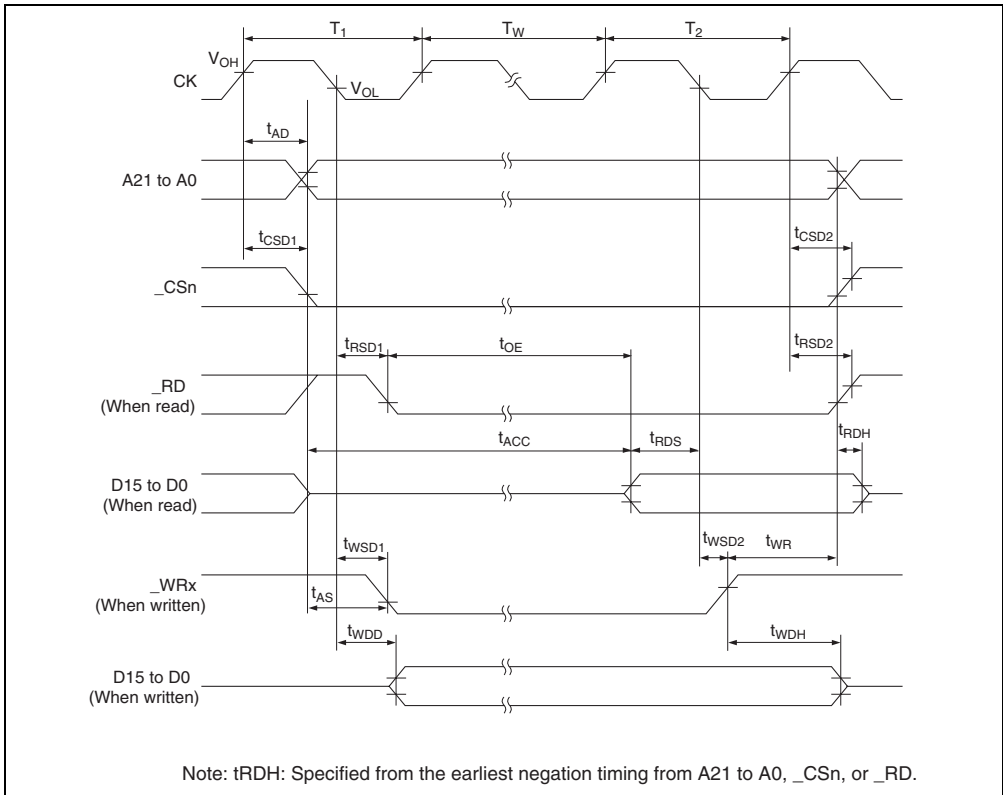

Figure 3.2 Basic Bus Cycle (Software Wait)

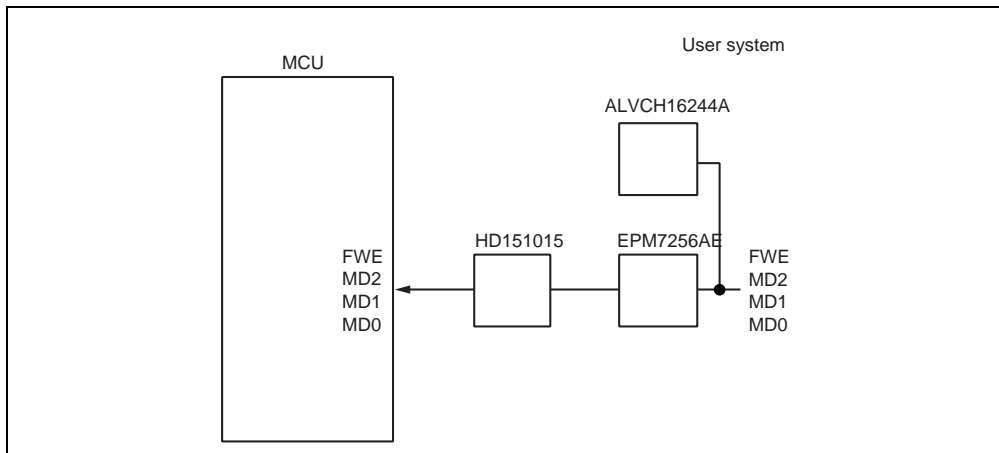

Figure 3.3 User System Interface Circuits (1)

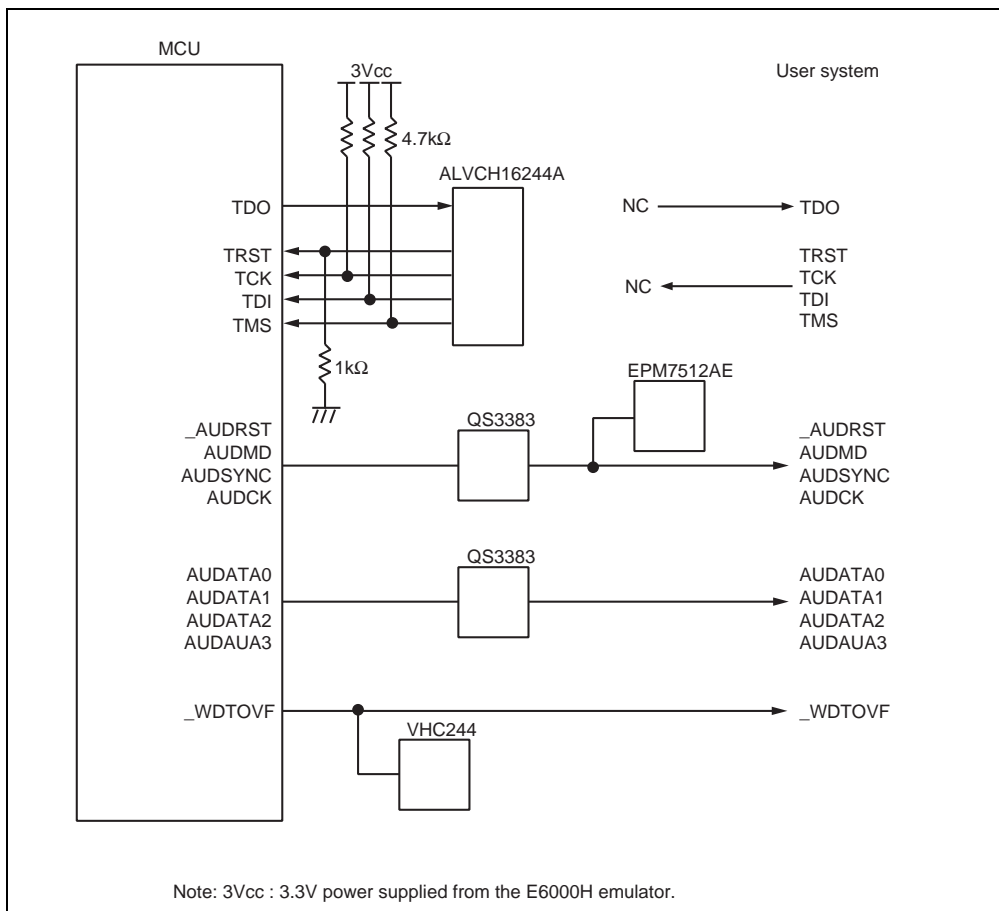

Figure 3.4 User System Interface Circuits (2)

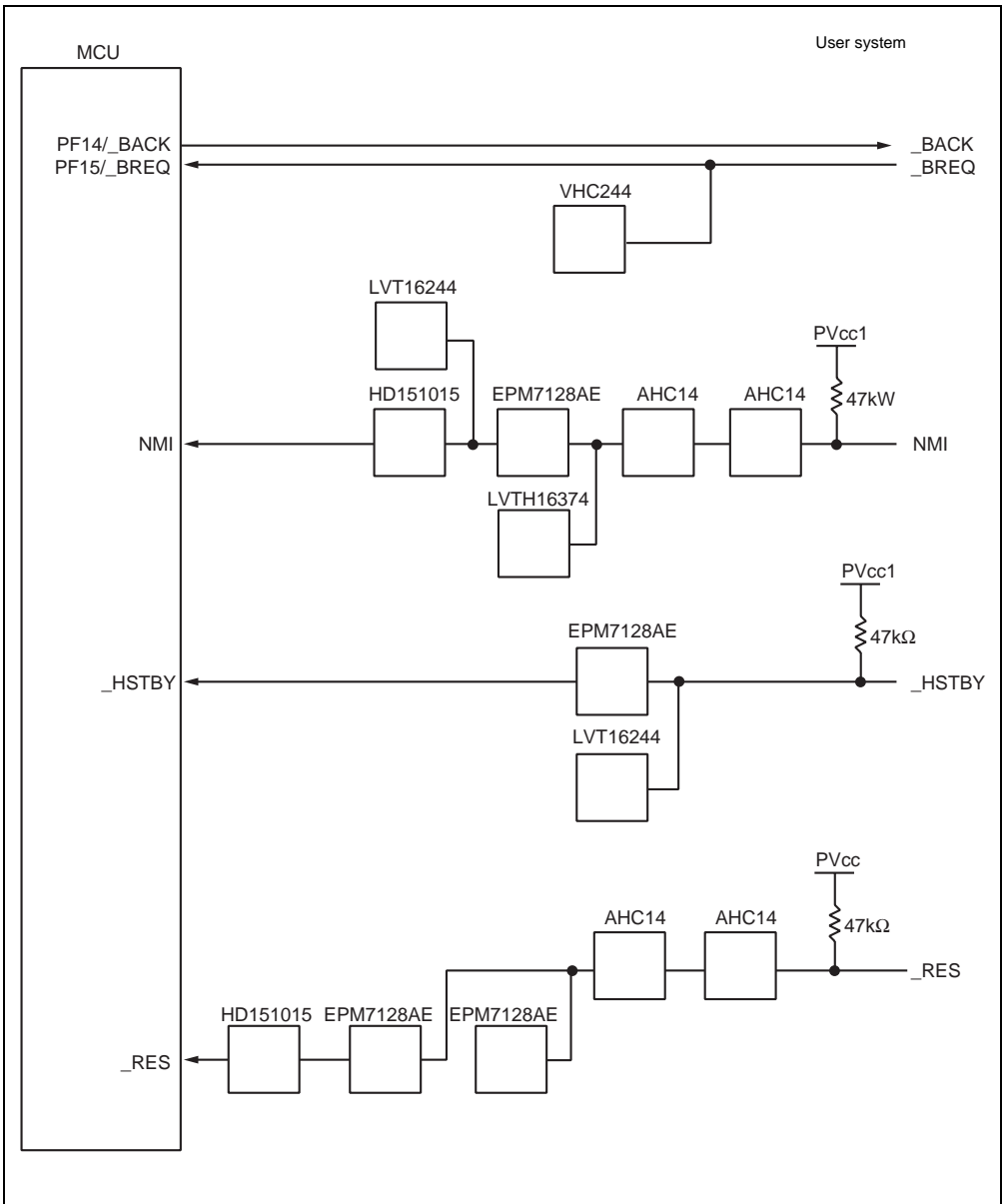

Figure 3.5 User System Interface Circuits (3)

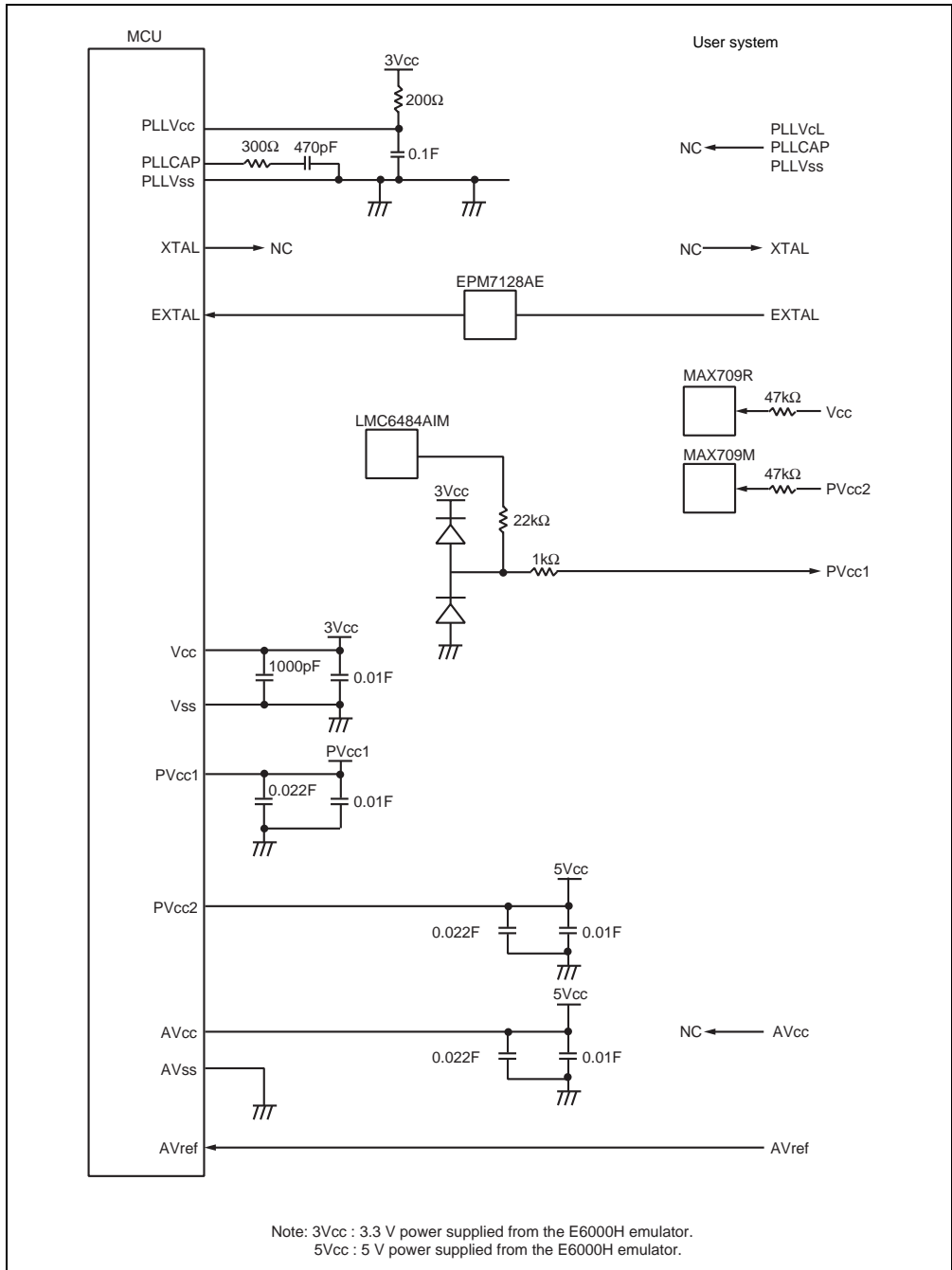

Figure 3.6 User System Interface Circuits (4)

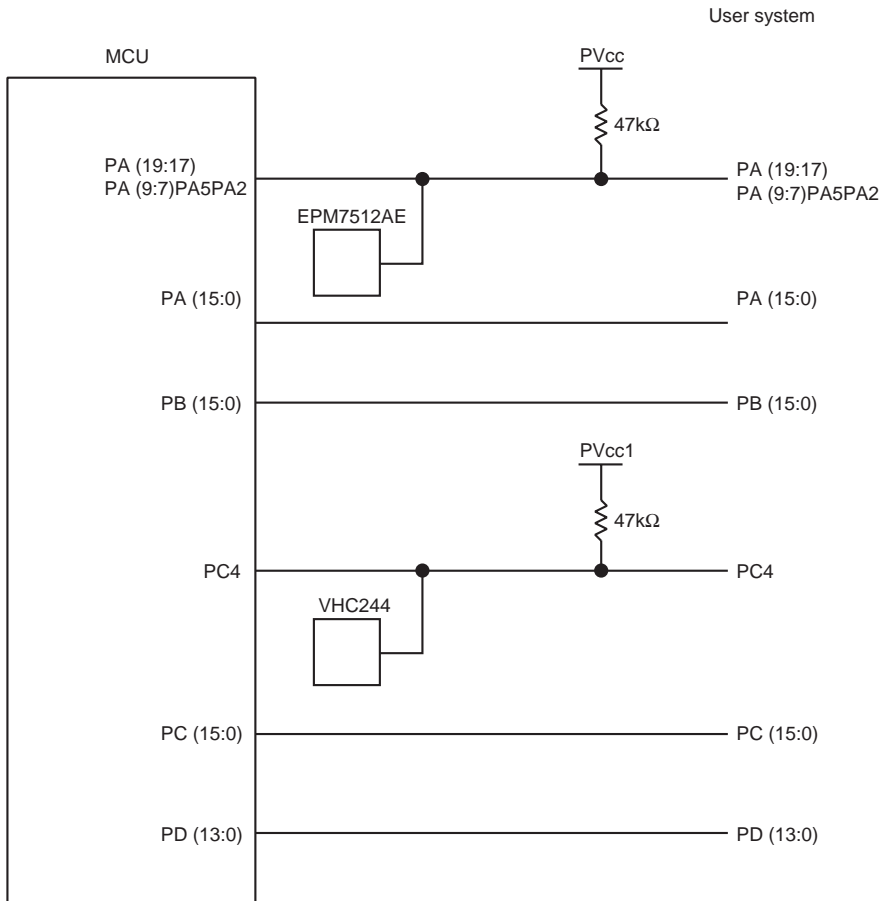

Figure 3.7 User System Interface Circuits (5)

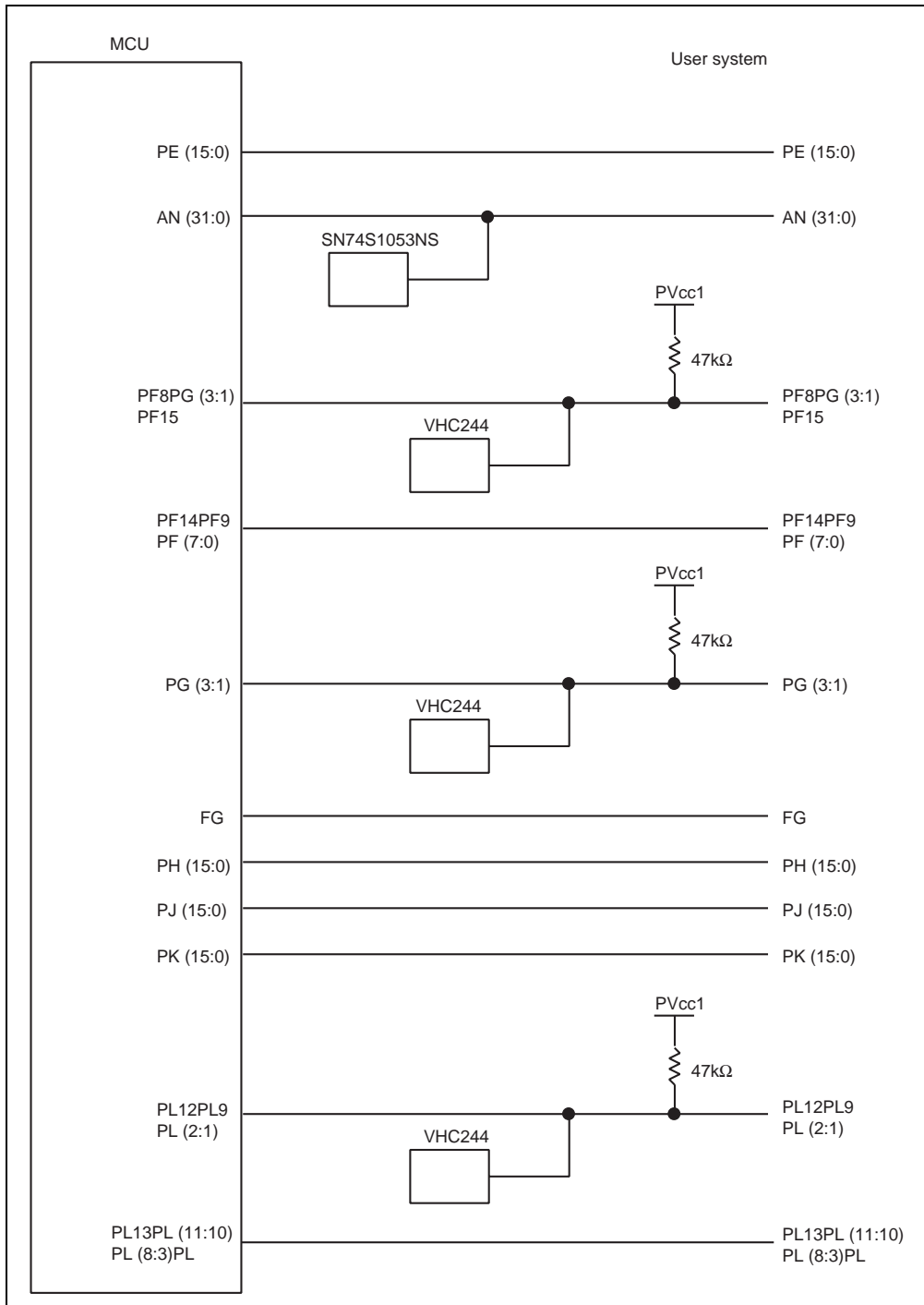

Figure 3.8 User System Interface Circuits (6)

3.3.2 Delay Time with the User System Interface

The delay time is generated on the timing of the _RES signal when it is input to the MCU from the user system, as shown in table 3.3, because this connection for this signal is via logic circuit on the evaluation chip board.

Table 3.3 Delay Time for Signal Connected via the Evaluation Chip Board

Signal Name	Delay Time (ns)
_RES	15.0

3.4 Connecting the Emulator to the User System

3.4.1 Connecting to the User System

WARNING

Always switch OFF the emulator and user system before connecting or disconnecting any CABLES. Failure to do so will result in a FIRE HAZARD, and will damage the user system or emulator or result in PERSONAL INJURY. Also, the USER PROGRAM will be LOST.

The emulator is connected to the user system by using the user system interface board.

Table 3.4 User System Interface Board and User Interfaces

User System Interface Board	User Interface
HS7058ECF62H	PRQP0256KB-A (TQPACK256RD)*
HS7058ECB62H	PRBG0272FA-A (CSPACK256Z2021H01)*

Note: The TQPACK and CSPACK series are manufactured by Tokyo Eletech Corporation.

Installing IC Socket

1. Installing IC Socket

Install the IC socket for each package to the user system. After checking the location of pin 1 on the IC socket, apply epoxy resin adhesive to the bottom of the IC, and fasten it to the user system before soldering.

2. Soldering IC Socket

After fastening, solder the IC socket to the user system. Be sure to completely solder the leads so that the solder slops gently over the leads and forms solder fillets. (Use slightly more solder than the MCU.)

Connection Using the HS7058ECF62H

WARNING

Always switch OFF the emulator and user system before connecting or disconnecting any CABLES. Failure to do so will result in a FIRE HAZARD, and will damage the user system or emulator or result in PERSONAL INJURY. Also, the USER PROGRAM will be LOST.

- Notes:
1. For more details on the HS7058ECF62H, refer to the user's manual supplied with the emulator.
 2. This user system interface board can only be used in combination with the specified QFP socket (TQPACK256RD).

Install the PRQP0256KB-A IC socket (TQPACK256RD manufactured by Tokyo Eletech Corporation) on the user system to connect the emulator. Since the pin assignment is the same as that of the actual MCU (SH7058, SH7058S, SH7059), refer to the hardware manual.

Figures 3.9 to 3.11 show the connection of the HS7058ECF62H, the size restrictions for the installed components of the HS7058ECF62H, and the recommended mount pad dimensions of the user system IC socket, respectively.

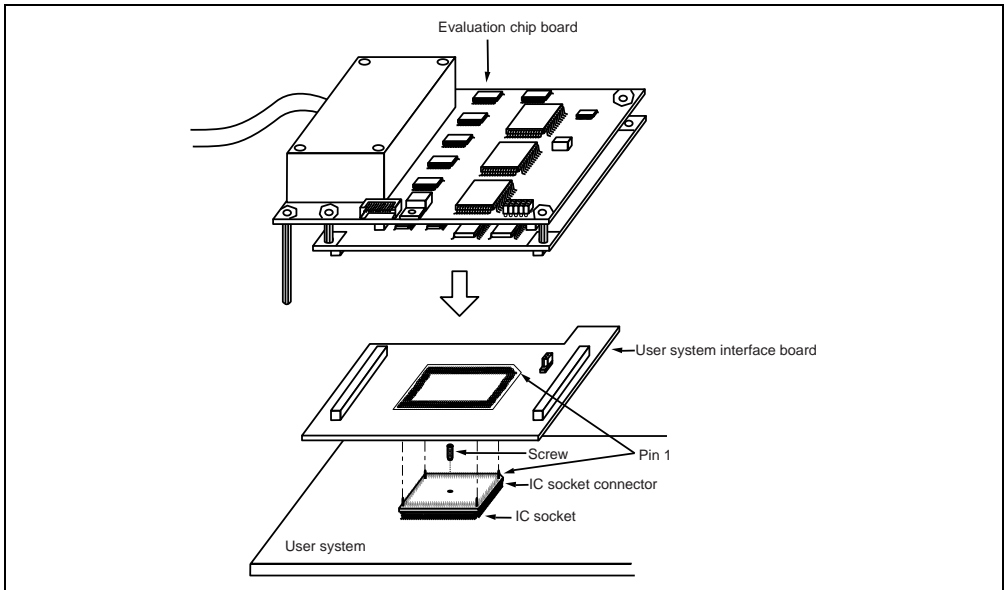

Figure 3.9 Connection Using the HS7058ECF62H

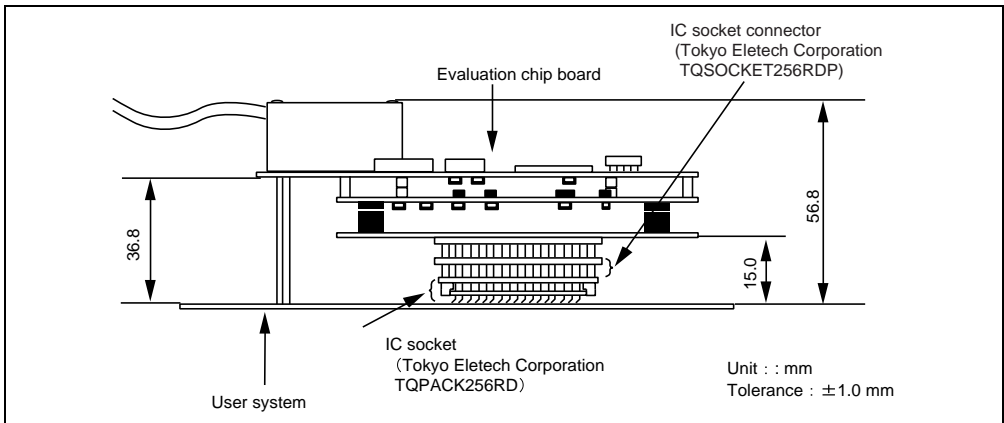

Figure 3.10 Restrictions on Component Installation

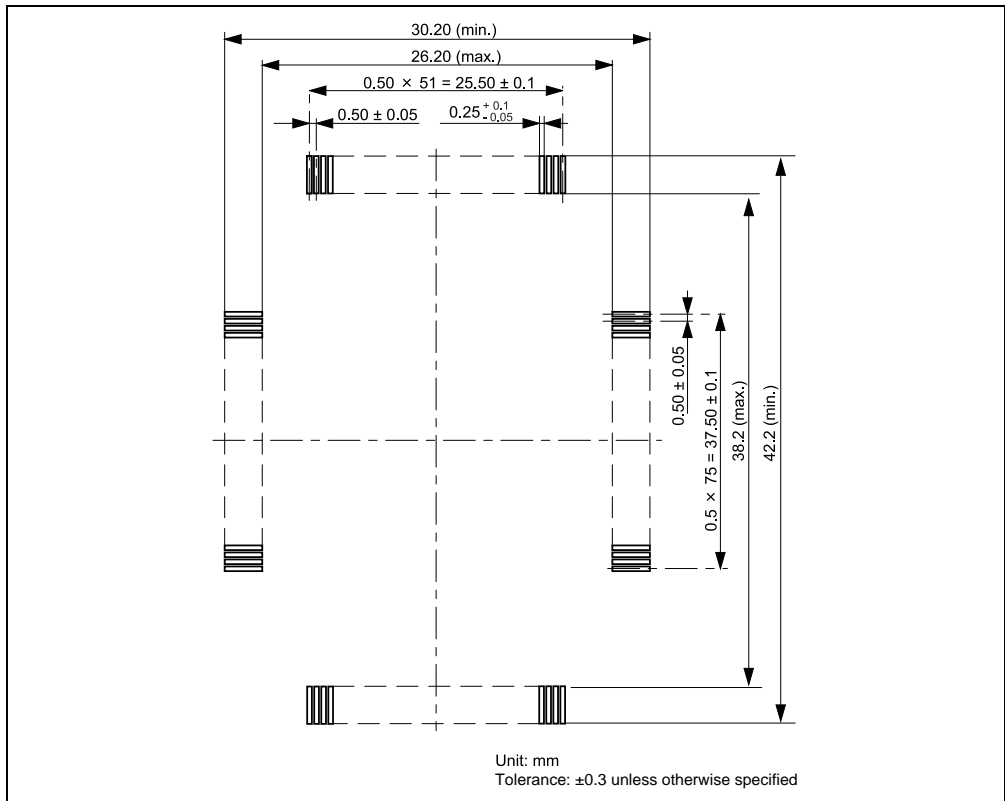

Figure 3.11 Recommended Mount Pad Dimensions of the User System IC Socket

Connection Using the HS7058ECB62H **WARNING**

Always switch OFF the emulator and user system before connecting or disconnecting any CABLES. Failure to do so will result in a FIRE HAZARD, and will damage the user system or emulator or result in PERSONAL INJURY. Also, the USER PROGRAM will be LOST.

- Notes:
1. For more details on the HS7058ECB62H, refer to the user's manual supplied with the emulator.
 2. This user system interface board can only be used in combination with the specified BGA socket (CSPACK256Z2021H01).

Install the PRBG0272FA-A IC socket (CSPACK256Z2021H01 manufactured by Tokyo Eletech Corporation) on the user system to connect the emulator. Since the pin assignment is the same as that of the actual MCU, refer to the hardware manual.

Figures 3.12 to 3.14 show the connection of the HS7058ECB62H, the size restrictions for the installed components of the HS7058ECB62H, and the recommended mount pad dimensions of the user system IC socket, respectively.

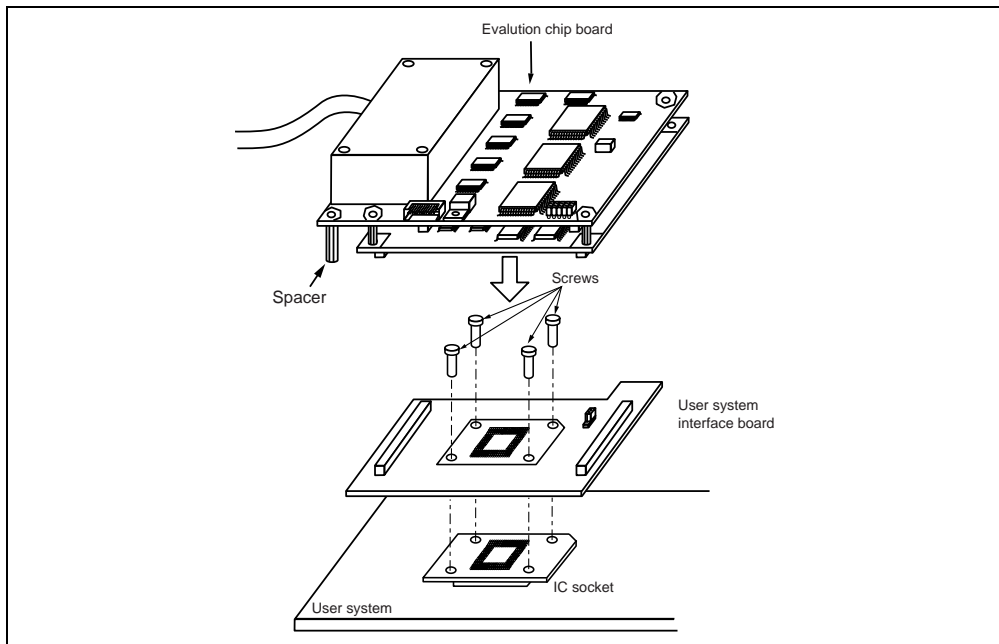

Figure 3.12 Connection Using the HS7058ECB62H

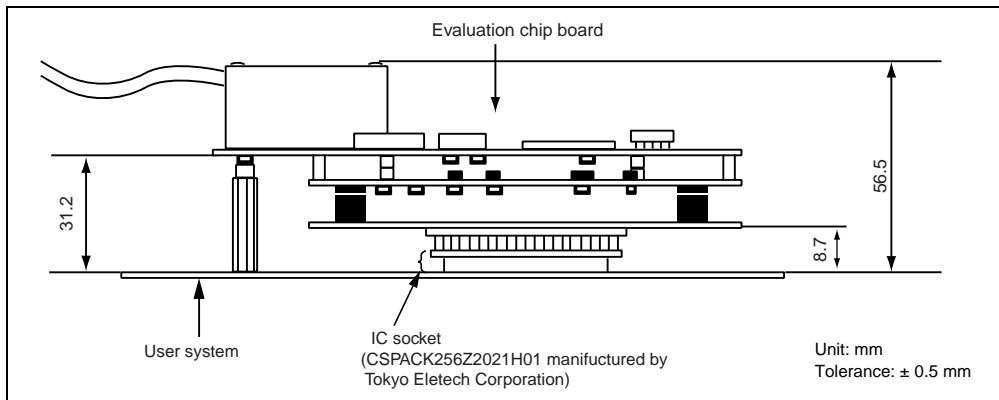

Figure 3.13 Restrictions on Component Installation

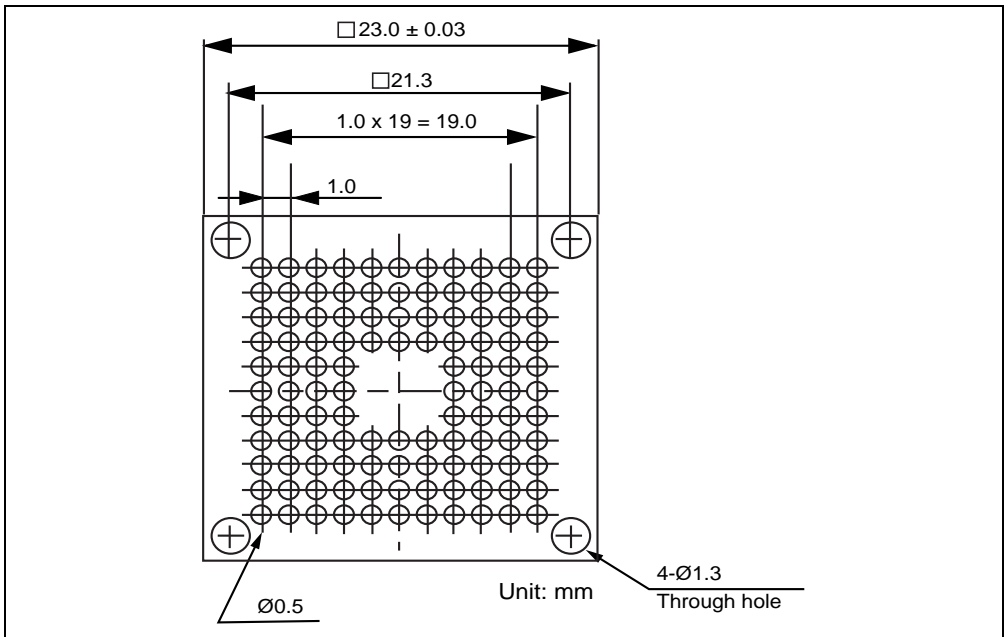

Figure 3.14 Recommended Mount Pad Dimensions of the User System IC Socket

Connection Using the Dedicated Connector

! WARNING

Always switch OFF the emulator and user system before connecting or disconnecting any CABLES. Failure to do so will result in a FIRE HAZARD, and will damage the user system or emulator or result in PERSONAL INJURY. Also, the USER PROGRAM will be LOST.

Note: This evaluation chip board can only be used in combination with the specified dedicated connector (QTH-090-0x-L-D-A).

Install the dedicated connector (QTH-090-0x-L-D-A manufactured by Samtec, Inc.) on the user system to connect the emulator. Figures 3.15 to 3.17 show connection using the dedicated connector, size restrictions for the installed components, and the location for mounting the connector in the user system, respectively.

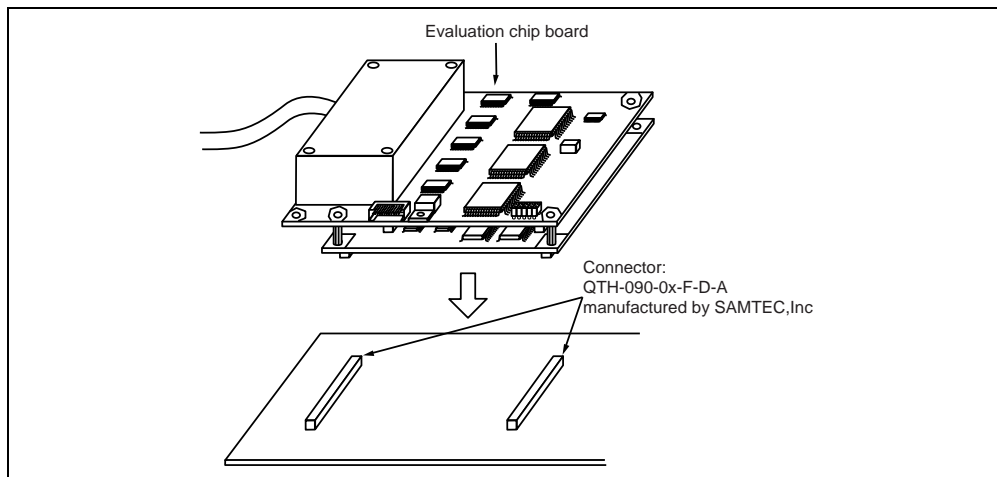

Figure 3.15 Connection Using the Dedicated Connector

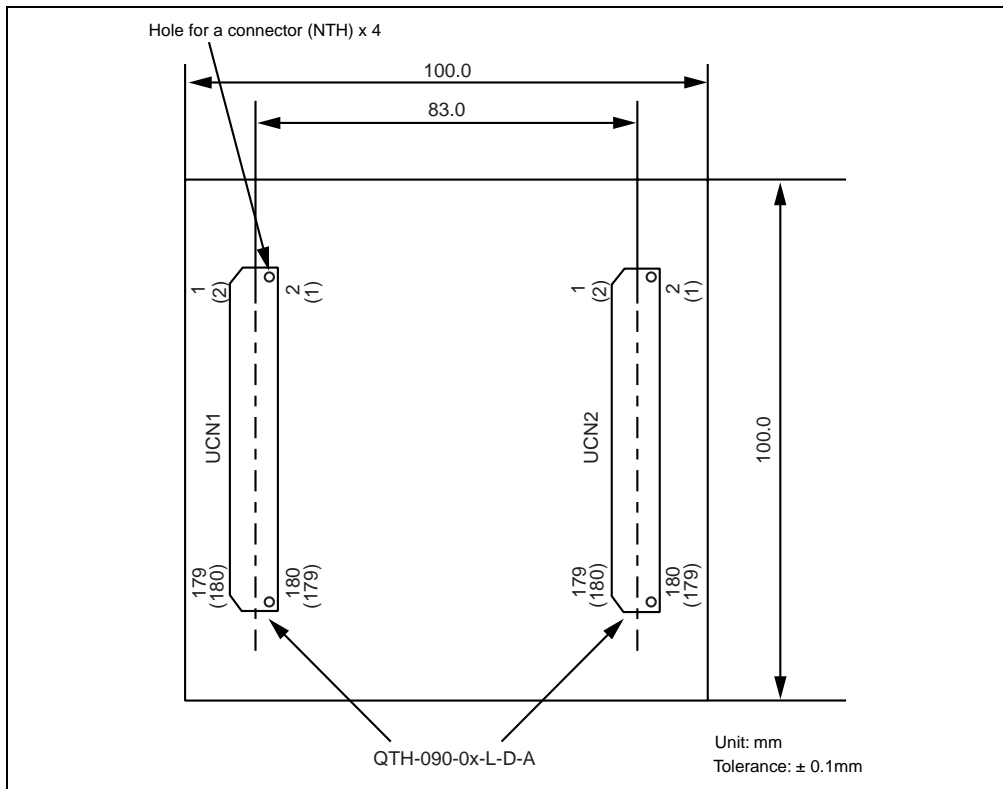

Figure 3.16 Location for Mounting the Connector in the User System

To design the foot pattern, refer to the catalog on QTH-090-0x-L-D-A for dimensions.

CAUTION

The pin numbers indicated on the board (shown in figure 3.16 without brackets) differ from those designated by Samtec, Inc (shown in figure 3.16 with brackets). Be sure to install the connector and make the signal wiring, properly.

3.4.2 Pin Assignment on the User System Interface Connector

Table 3.5 lists the pin assignment on the user system interface connector of HS7058EPH62H and HS7059EPH62H.

Table 3.5 Pin Assignment on HS7058EPH62H and HS7059EPH62H

User I/F 1	Pin No. Indicated on the Board	Pin No. Designated by Samtec Inc.	Signal Name
UCN1	1	(2)	GND
	2	(1)	GND
	3	(4)	GND
	4	(3)	GND
	5	(6)	GND (TG BON1)
	6	(5)	GND
	7	(8)	PE15/A15
	8	(7)	PF15/_BREQ
	9	(10)	PE14/A14
	10	(9)	PF14/_BACK
	11	(12)	PE13/A13
	12	(11)	PF13/_CS3
	13	(14)	PE12/A12
	14	(13)	PF12/_CS2
	15	(16)	GND
	16	(15)	GND
	17	(18)	PE11/A11
	18	(17)	PF11/_CS1
	19	(20)	PE10/A10
	20	(19)	PF10/_CS0
	21	(22)	PE9/A9
	22	(21)	PF9/_RD
	23	(24)	PE8/A8
	24	(23)	PF8/_WAIT
	25	(26)	GND
	26	(25)	GND
	27	(28)	PE7/A7
	28	(27)	PF7/_WRH
	29	(30)	PE6/A6
	30	(29)	PF6/_WRL
	31	(32)	PE5/A5
	32	(31)	PF5/A21/_POD
	33	(34)	PE4/A4

Table 3.5 HS7058EPH62H and HS7059EPH62H

User I/F 1	Pin No. Indicated on the Board	Pin No. Designated by Samtec Inc.	Signal Name
UCN1	34	(33)	PF4/A20
	35	(36)	GND
	36	(35)	GND
	37	(38)	PE3/A3
	38	(37)	PF3/A19
	39	(40)	PE2/A2
	40	(39)	PF2/A18
	41	(42)	PE1/A1
	42	(41)	PF1/A17
	43	(44)	PE0/A0
	44	(43)	PF0/A16
	45	(46)	GND
	46	(45)	PD13/PULS6/HRxD0/HTxD1
	47	(48)	GND
	48	(47)	PD12/PULS4
	49	(50)	GND
	50	(49)	GND
	51	(52)	GND
	52	(51)	PD11/PULS3
	53	(54)	GND
	54	(53)	PD10/PULS2
	55	(56)	PD9/PULS1
	56	(55)	GND
	57	(58)	PD8/PULS0
	58	(57)	GND
	59	(60)	GND
	60	(59)	GND
	61	(62)	PD7/TIO1H
	62	(61)	GND
	63	(64)	PD6/TIO1G
	64	(63)	GND
	65	(66)	PD5/TIO1F
	66	(65)	PD4/TIO1E
	67	(68)	GND
68	(67)	GND	
69	(70)	GND	
70	(69)	PD3/TIO1D	

Table 3.5 HS7058EPH62H and HS7059EPH62H

User I/F 1	Pin No. Indicated on the Board	Pin No. Designated by Samtec Inc.	Signal Name
UCN1	71	(72)	GND
	72	(71)	PD2/TIO1C
	73	(74)	GND
	74	(73)	PD1/TIO1B
	75	(76)	GND
	76	(75)	PD0/TIO1A
	77	(78)	AUDCK
	78	(77)	AUDMD
	79	(80)	PL13/_IRQOUT
	80	(79)	_AUDSYNC
	81	(82)	PL12/_IRQ4
	82	(81)	_AUDRST
	83	(84)	GND
	84	(83)	GND
	85	(86)	PL11/HRxD/HRxD1
	86	(85)	AUDATA3
	87	(88)	PL10/HTxD0/HTxD1/HTxD0&HTxD1
	88	(87)	AUDATA2
	89	(90)	PL9/SCK4/_IRQ5
	90	(89)	AUDATA1
	91	(92)	PL8/SCK3
	92	(91)	AUDATA0
	93	(94)	GND
	94	(93)	PL7/SCK2
	95	(96)	3Vcc
	96	(95)	PL6/ADEND
	97	(98)	3Vcc
	98	(97)	PL5/_ADTRG1
	99	(100)	3Vcc
	100	(99)	PL4/_ADTRG0
101	(102)	3Vcc	
102	(101)	GND	
103	(104)	3Vcc	
104	(103)	PL3/TCLKB	
105	(106)	3Vcc	
106	(105)	PL2/TIO11B/_IRQ7	

Table 3.5 HS7058EPH62H and HS7059EPH62H

User I/F 1	Pin No. Indicated on the Board	Pin No. Designated by Samtec Inc.	Signal Name
UCN1	107	(108)	5Vcc
	108	(107)	PL1/TIO11A/_IRQ6
	109	(110)	5Vcc
	110	(109)	PL0/TI10
	111	(112)	5Vcc
	112	(111)	GND
	113	(114)	5Vcc
	114	(113)	PK15/TO8P
	115	(116)	5Vcc
	116	(115)	PK14/TO8O
	117	(118)	5Vcc
	118	(117)	PK13/TO8N
	119	(120)	GND
	120	(119)	PK12/TO8M
	121	(122)	GND
	122	(121)	GND
	123	(124)	PK11/TO8L
	124	(123)	GND
	125	(126)	PK10/TO8K
	126	(125)	GND
	127	(128)	PK9/TO8J
	128	(127)	GND
	129	(130)	PK8/TO8I
	130	(129)	GND
	131	(132)	PK7/TO8H
	132	(131)	PK6/TO8G
133	(134)	PK5/TO8F	
134	(133)	PK4/TO8E	
135	(136)	PK3/TO8D	
136	(135)	PK2/TO8C	
137	(138)	PK1/TO8B	
138	(137)	GND	
139	(140)	PK0/TO8A	
140	(139)	GND	
141	(142)	GND	
142	(141)	GND	
143	(144)	PJ15/TI9F	

Table 3.5 HS7058EPH62H and HS7059EPH62H

User I/F 1	Pin No. Indicated on the Board	Pin No. Designated by Samtec Inc.	Signal Name
UCN1	144	(143)	GND
	145	(146)	PJ14/TI9E
	146	(145)	GND
	147	(148)	PJ13/TI9D
	148	(147)	PJ12/TI9C
	149	(150)	GND
	150	(149)	GND
	151	(152)	GND
	152	(151)	PJ11/TI9B
	153	(154)	GND
	154	(153)	PJ10/TI9A
	155	(156)	GND
	156	(155)	PJ9/TIO5D
	157	(158)	GND
	158	(157)	PJ8TIO5C
	159	(160)	GND
	160	(159)	GND
	161	(162)	PJ7/TIO2H
	162	(161)	GND
	163	(164)	PJ6/TIO2G
	164	(163)	GND
	165	(166)	PJ5/TIO2F
	166	(165)	GND
	167	(168)	PJ4/TIO2E
	168	(167)	PG3/_IRQ3/_ADTRG0
	169	(170)	GND
	170	(169)	PG2/_IRQ2/ADEND
	171	(172)	PJ3/TIO2D
	172	(171)	PG1/_IRQ1
	173	(174)	PJ2/TIO2C
174	(173)	PG0/PULS7/HRxD0/HRxD1	
175	(176)	PJ1/TIO2B	
176	(175)	PJ0/TIO2A	
177	(178)	GND	
178	(177)	GND	
179	(180)	GND	
180	(179)	GND	

Table 3.5 HS7058EPH62H and HS7059EPH62H

User I/F 1	Pin No. Indicated on the Board	Pin No. Designated by Samtec Inc.	Signal Name
UCN2	1	(2)	GND
	2	(1)	GND
	3	(4)	GND
	4	(3)	GND
	5	(6)	GND
	6	(5)	GND
	7	(8)	GND
	8	(7)	GND
	9	(10)	PH0/D0
	10	(9)	FWE
	11	(12)	PH1/D1
	12	(11)	MD2
	13	(14)	PH2/D2
	14	(13)	MD1
	15	(16)	PH3/D3
	16	(15)	MD0
	17	(18)	GND
	18	(17)	PH4/D4
	19	(20)	EXTAL
	20	(19)	PH5/D5
	21	(22)	GND
	22	(21)	PH6/D6
	23	(24)	_RES
	24	(23)	PH7/D7
	25	(26)	GND
	26	(25)	GND
	27	(28)	_HSTBY
	28	(27)	PH8/D8
	29	(30)	GND
	30	(29)	PH9/D9
	31	(32)	CK
	32	(31)	PH10/D10
	33	(34)	GND
	34	(33)	PH11/D11
	35	(36)	GND
	36	(35)	GND
	37	(38)	PH12/D12

Table 3.5 HS7058EPH62H / HS7059EPH62H

User I/F 1	Pin No. Indicated on the Board	Pin No. Designated by Samtec Inc.	Signal Name
UCN2	38	(37)	GND
	39	(40)	PH13/D13
	40	(39)	GND
	41	(42)	PH14/D14
	42	(41)	GND
	43	(44)	PH15/D15
	44	(43)	GND
	45	(46)	Vcc
	46	(45)	GND
	47	(48)	Vcc
	48	(47)	GND
	49	(50)	Vcc
	50	(49)	GND
	51	(52)	PVcc1
	52	(51)	GND
	53	(54)	PVcc1
	54	(53)	GND
	55	(56)	PVcc1
	56	(55)	PVcc2
	57	(58)	GND
	58	(57)	PVcc2
	59	(60)	AN0
	60	(59)	PVcc2
	61	(62)	AN1
	62	(61)	GND
	63	(64)	AN2
	64	(63)	GND
	65	(66)	AN3
	66	(65)	GND
	67	(68)	GND
	68	(67)	GND
	69	(70)	AN4
	70	(69)	AN5
	71	(72)	GND
72	(71)	AN6	
73	(74)	AN7	
74	(73)	NMI	

Table 3.5 HS7058EPH62H / HS7059EPH62H

User I/F 1	Pin No. Indicated on the Board	Pin No. Designated by Samtec Inc.	Signal Name
UCN2	75	(76)	GND
	76	(75)	AN8
	77	(78)	AN9
	78	(77)	AN10
	79	(80)	AN11
	80	(79)	GND
	81	(82)	AN12
	82	(81)	AN13
	83	(84)	AN14
	84	(83)	AN15
	85	(86)	GND
	86	(85)	AVcc
	87	(88)	AN16
	88	(87)	AVcc
	89	(90)	AN17
	90	(89)	AVcc
	91	(92)	AN18
	92	(91)	AVcc
	93	(94)	AN19
	94	(93)	AVref
	95	(96)	GND
	96	(95)	AVref
	97	(98)	AN20
	98	(97)	AVss
	99	(100)	AN21
	100	(99)	AVss
	101	(102)	AN22
	102	(101)	AVss
	103	(104)	AN23
	104	(103)	AVss
	105	(106)	GND
106	(105)	AN24	
107	(108)	GND	
108	(107)	AN25	
109	(110)	_WDTOVF	
110	(109)	AN26	
111	(112)	GND	

Table 3.5 HS7058EPH62H and HS7059EPH62H

User I/F 1	Pin No. Indicated on the Board	Pin No. Designated by Samtec Inc.	Signal Name
UCN2	112	(111)	AN27
	113	(114)	GND
	114	(113)	GND
	115	(116)	GND
	116	(115)	AN28
	117	(118)	GND
	118	(117)	AN29
	119	(120)	AN30
	120	(119)	GND
	121	(122)	AN31
	122	(121)	GND
	123	(124)	GND
	124	(123)	GND
	125	(126)	PA0/TIOA
	126	(125)	GND
	127	(128)	PA1/TIOB
	128	(127)	GND
	129	(130)	PA2/TIO C
	130	(129)	PA3/TIO D
	131	(132)	GND
	132	(131)	GND
	133	(134)	GND
	134	(133)	PA4/TIO3A
	135	(136)	GND
	136	(135)	PA5/TIO3B
	137	(138)	PB0/TO6A
	138	(137)	PA6/TIO3C
	139	(140)	PB1/TO6B
	140	(139)	PA7/TIO3D
	141	(142)	PB2/TO6C
142	(141)	GND	
143	(144)	PB3/TO6D	
144	(143)	PA8/TIO4A	
145	(146)	GND	
146	(145)	PA9/TIO4B	
147	(148)	PB4/TO7A/TO8A	
148	(147)	PA10/TIO4C	

Table 3.5 HS7058EPH62H and HS7059EPH62H

User I/F 1	Pin No. Indicated on the Board	Pin No. Designated by Samtec Inc.	Signal Name
UCN2	149	(150)	PB5/TO7B/TO8B
	150	(149)	PA11/TIO4D
	151	(152)	PB6/TO7C/TO8C
	152	(151)	PB7/TO7D/TO8D
	153	(154)	PA12/TIO5A
	154	(153)	GND
	155	(156)	PA13/TIO5B
	156	(155)	PB8/TxD3/TO8E
	157	(158)	PA14/TxD0
	158	(157)	PB9/RxD3/TO8F
	159	(160)	PA15/RxD0
	160	(159)	PB10/TxD4/HTxD0/TO8G
	161	(162)	GND
	162	(161)	PB11/RxD4/HRxD0/TO8H
	163	(164)	PC0/TxD1
	164	(163)	GND
	165	(166)	PC1/RxD1
	166	(165)	PB12/TCLKA/_UBCTRG
	167	(168)	PC2/TxD2
	168	(167)	PB13/SCK0
	169	(170)	PC3/RxD2
	170	(169)	PB14/SCK1/TCLKB/TI10
	171	(172)	PC4/_IRQ0
	172	(171)	PB15/PULS5/SCK2
	173	(174)	GND
	174	(173)	GND (TG BON2)
	175	(176)	GND
176	(175)	GND	
177	(178)	GND	
178	(177)	GND	
179	(180)	GND	
180	(179)	GND	

3.4.3 Precautions on Connecting the User System

When connecting the evaluation chip board to the user system, note the following:

1. Secure the E6000H station location.

Place the E6000H station and evaluation chip board so that the station to trace cable is not bent or twisted, as shown below. A bent or twisted cable will impose stress on the user interface, leading to connection or contact failure. Make sure that the E6000H station is placed in a secure position so that it does not move and impose stress on the user interface during use.

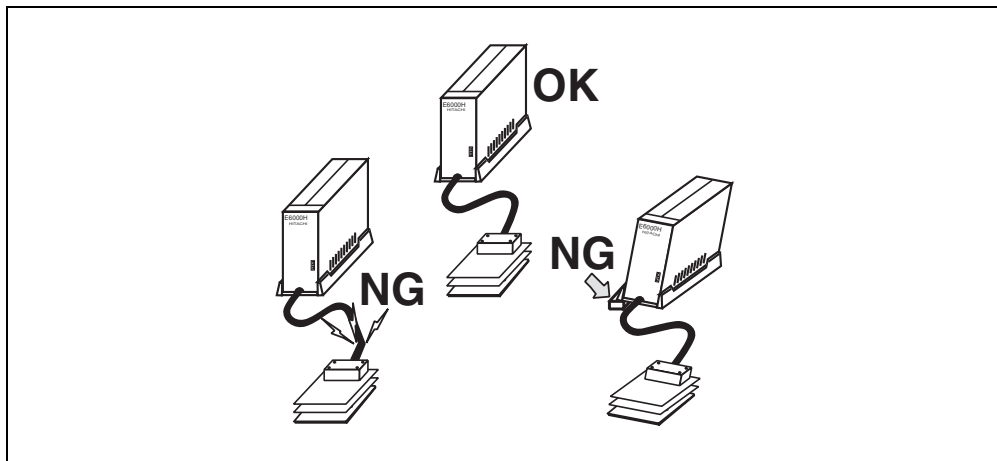

2. Make sure the power supply is off.

Before connecting the evaluation chip board to the user system, check that the emulator and the user system are turned off.

3. Connect the Vcc, PVcc1, and PVcc2 to the user system power.

The emulator monitors and decides whether the user system is turned on or off by the following Vcc pins:

(a) Connecting the dedicated connector for HS7058EPH62H

Vcc: Pins UCN2-45, UCN2-47, and UCN2-49

PVcc1: Pins UCN2-51, UCN2-53, and UCN2-55

PVcc2: Pins UCN2-56, UCN2-58, and UCN2-60

(b) Connecting the user system interface board

Vcc, PVcc1, and PVcc2 pins of each package

For the pin assignment, refer to the SH7050 series (F-ZTAT microcomputer) hardware manual.

Accordingly, after connecting the user system to the emulator, be sure to supply power to the Vcc pins.

Otherwise, the emulator assumes that the user system is not connected.

When the user system is connected, check that the power of the user system is supplied to these pins.

3.5 Support of the Target MCU

3.5.1 Memory Space

The MCU has a 4-Gbyte memory space in its architecture.

On-Chip Flash Memory Area

- Access to the on-chip flash memory area

The emulator includes on-chip flash memory for the MCU. The on-chip flash memory is accessed in the mode where the on-chip flash memory exists. The on-chip flash memory area access differs between user program execution and the emulator commands.

Only read access is enabled during execution of the user program. A break does not occur if the on-chip flash memory area is written to.

For access with emulator functions ([Memory] window or loading), read and write are always enabled.

The on-chip flash memory area is accessed in one state.

On-Chip I/O Area

If an attempt is made to access the on-chip I/O area, the on-chip I/O area in the MCU installed in the emulator is accessed. To break the user program when the on-chip I/O area is written to or accessed, use the hardware break or internal break.

External Memory Area

The MCU's external memory area can be set with all memory attributes that the emulator supports.

Emulation RAM Area

The emulator includes the emulation RAM for the RAM emulation of the on-chip flash memory:

The emulation RAM area for HS7058EPH62H (16 kbytes × 16 blocks)

The emulation RAM area for HS7059EPH62H (16 kbytes × 24 blocks)

This emulation RAM (ERAM) can be used by overlapping with the on-chip flash memory address. If an attempt is made to write the address that overlaps ERAM to the on-chip flash memory area, the address is written by ERAM and a break does not occur.

3.5.2 Low Power-Consumption Mode (Sleep, Software Standby, and Hardware Standby)

For reduced power consumption, the MCU has sleep, software standby, and hardware standby modes.

Hardware Standby Mode

Since the `_HSTBY` signal from the user system is not input to the MCU in the emulator, the emulator does not support this mode.

Sleep and Software Standby Modes

- Break
The sleep and software standby modes can be cleared with either the normal clearing function or with the break condition satisfaction (forced break), and the program breaks. When restarting after a break, the user program will restart at the instruction following the SLEEP instruction.
- Trace
Trace information is not acquired in these modes.
- Memory access with emulator functions
For information on displaying and modifying the contents of memory in the sleep and software standby modes, refer to section 5.4, Displaying and Modifying the Contents of Memory.

3.5.3 Interrupts

During execution and step execution, the user can interrupt the MCU.

During halting emulation (break mode), the interrupt source is retained. The mode transits the interrupt processing immediately after emulation is restarted.

3.5.4 Control Input Signals (`_RES`, `_BREQ`, and `_WAIT`)

The MCU control input signals are `_RES`, `_BREQ`, and `_WAIT`.

The `_RES` signal is only valid when emulation has been started with normal program execution (i.e., the `_RES` signal is invalid when emulation has been started with step execution). The `_BREQ` and `_WAIT` signals are valid during emulation with the display and modification of memory contents, execution, and step execution. While emulation is being halted (break), the input of the `_RES`, `_BREQ`, or `_WAIT` signal to the MCU by the user system is not possible.

The input of the `_RES`, `_BREQ`, or `_WAIT` signal during execution or step execution can be disabled by a setting in the [Configuration Properties] dialog box.

3.5.5 Watchdog Timer (WDT)

While emulation is being halted (during break), counting up the WDT timer counter (TCNT) is suspended, and restarted when emulation is executed again (user mode).

During break mode, a prescaler, which supplies a clock to TCNT, operates continuously. Since the phase of the prescaler may be unmatched before or after emulation transits the break mode, the period before an overflow occurs will differ by ± 1 cycle in the prescaler's clock cycle.

3.5.6 A/D Converter

The A/D converter has AVcc, AVss, Avref, and _ADTRG pins as well as the analog input pins. As the A/D converter operates with an independent power supply, connect AVcc (the power supply pin) to the A/D power supply on the user system.

- Notes:
1. When not using the A/D converter, connect AVcc to Vcc.
 2. As the user system interface board, printed circuit boards, and protective circuits are connected between the user system and the MCU installed on the evaluation chip board, the conversion precision is lower than that of the SH7050 series MCU. At final debugging of the user system using the A/D converter, use the actual SH7050 series (F-ZTAT microcomputer) MCU.

3.5.7 Emulator State and On-Chip Modules

Some on-chip modules do not operate when the emulator is in break mode. Table 3.6 shows the relation between the emulator's state and operation of the on-chip modules.

Table 3.6 Emulator State and Operation of On-Chip Modules

Internal Module	Operation During Emulation Halted (Break)	Operation During Emulation (Execution or Step Execution)
UBC (user break controller)	No	Yes
DMAC (direct memory access controller)	Yes	Yes
ATU-II (advanced timer unit)	Yes	Yes
APC (advanced pulse controller)	Yes	Yes
WDT (watchdog timer)	No	Yes
CMT (compare-match timer)	Yes	Yes
SCI (serial communication interface)	Yes	Yes
HCAN2	Yes	Yes
A/D converter	Yes	Yes
AUD (advanced user debugger)	Yes ¹	Yes ¹
I/O port	Yes	Yes
H-UDI (user debugging interface)	Not available ²	Not available ²

- Notes:
1. The AUD can be used by the user or the emulator function. Therefore, when the AUD is used by the emulator, it is not available for the user.
 2. The user cannot use the H-UDI.

3.5.8 Different Initial Values of Registers in the Emulator

Note that the emulator initializes some general or control registers whenever the system is activated or the MCU is reset by commands.

Table 3.7 Initial Values of Registers in the MCU and the Emulator

Register Name	Emulator		
	Power On	Reset (Reset CPU)	MCU (Reset)
PC	Power-on reset vector PC value	Power-on reset vector PC value	Power-on reset vector PC value
R0 to R14	H'00000000	Value before reset	Undefined
R15 (SP)	Power-on reset vector SP value	Power-on reset vector SP value	Power-on reset vector SP value
SR	H'000000F0	H'000000F0	H'00000XFX*
GBR	H'00000000	Value before reset	Undefined
VBR	H'00000000	H'00000000	H'00000000
MACH	H'00000000	Value before reset	Undefined
MACL	H'00000000	Value before reset	Undefined
PR	H'00000000	Value before reset	Undefined

Note: X indicates an undefined value.

Section 4 Diagnostic Test Procedure

This section describes the diagnostic test procedure using the E6000H diagnostic program.

4.1 System Set-Up for Diagnostic Program Execution

To execute the diagnostic program, use the following hardware; do not connect the user system interface board and user system.

- E6000H (HS7058EPH62H or HS7059EPH62H)
 - Host computer
 - The E6000 PC interface board which will be one of the following boards:
 - PCI bus interface board (HS6000EIC01H or HS6000EIC02H)
 - PC card interface (HS6000EIP01H)
 - LAN adapter (HS6000ELN01H)
 - USB adapter (HS6000EIU01H or HS6000EIU02H)
1. Install the E6000 PC interface board in the host computer and connect the supplied PC interface cable to the board.
 2. Connect the PC interface cable to the E6000H.
 3. Connect the supplied AC power cable to the E6000H.
 4. Initiate the host computer to make it enter the command input wait state of the DOS prompt (Windows[®] 98SE or Windows[®] Me) or command prompt (Windows NT[®], Windows[®] 2000, or Windows[®] XP). If the property of the prompt window is not a mode for displaying the whole screen, press the [Alt + Enter] key to switch the mode. To set back the mode, press the [Alt + Enter] key. The display of the screen is switched regardless of the OS being used.

Note: In the MS-DOS prompt, if the display of the screen is not switched after pressing the [Alt + Enter] key, mark the [Alt+Enter] check box in [Windows shortcut keys] of the [Misc] page on the [MS-DOS Prompt Properties] dialog box and click the [Apply] button to update the settings, as shown in figure 4.1.

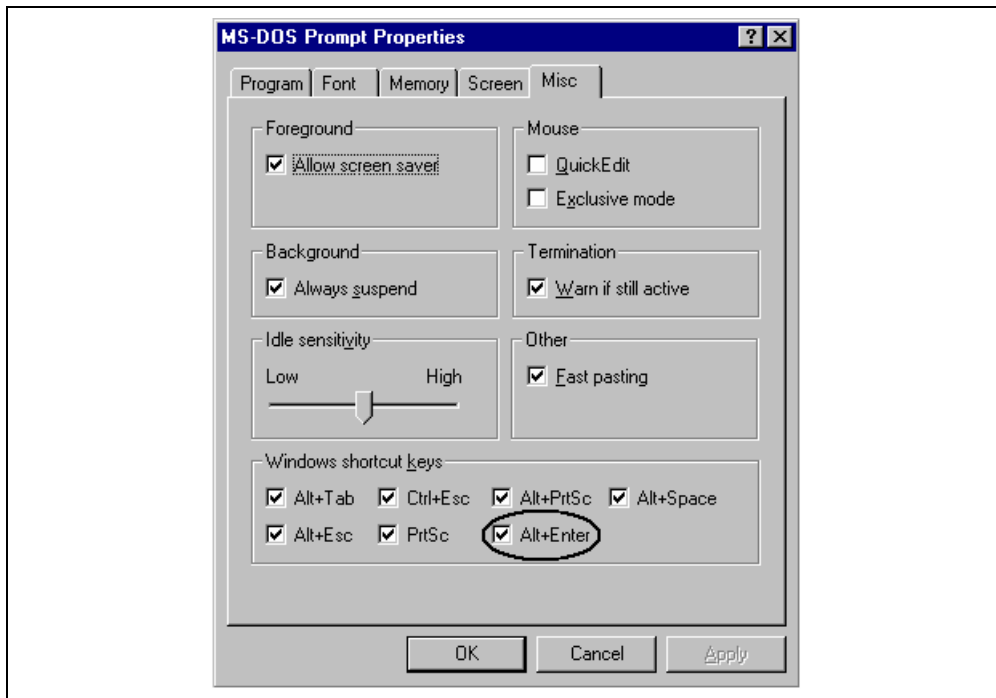

Figure 4.1 [Misc] Page

5. Turn on the E6000H emulator power switch.

Note: To execute the diagnostic program, firstly turn on the power of the emulator. In the diagnostic program, the initial state of hardware is checked. Therefore, after the power is turned on, do not activate the High-performance Embedded Workshop before executing the diagnostic program.

4.2 Test Item of the Diagnostic Program

Table 4.1 shows the test items of this diagnostic program.

Table 4.1 Test Items of the Diagnostic Program

Test No.	Test Item	Description
1	Main Board Access	Register test in the E6000H main board
2	Emulation Board Access	Register test in the E6000H emulation board
3	Evaluation Chip Board Access	Register test in the E6000H evaluation chip board
4	Basic Function	Test for the basic function
5	GO to BREAK Time Measurement	Test for the execution time measurement function
6	Emulation Monitor	Test for emulation monitor
7	G/A Break Function	Test for the G/A break function
8	G/A Performance Analysis Function	Test for the G/A performance measurement function
9	G/A Monitor Function	Test for the G/A monitoring function
10	G/A Parallel RAM Monitor	Test for the G/A parallel RAM monitoring function
11	G/A Trace Function	Test for the G/A trace function
12	Combination	Test for combination of each function
13	Parallel Access	Test for the parallel access function

4.3 Diagnostic Test Procedure Using the Diagnostic Program

Insert the CD-R (HS7058EPH60SR supplied with the E6000H) into the CD-ROM drive of the host computer. At the command prompt, change the current directory to <Drive>:\Diag\HS7058EPH60H for the HS7058EPH62H or to <Drive>:\Diag\HS7059EPH60H for the HS7059EPH62H, and then enter the command from the list below that corresponds with the PC interface board in use.

1. PCI bus interface board (HS6000EIC01H or HS6000EIC02H)
 - > TM7058 –PCI (ENTER) for the HS7058EPH62H
 - > TM7059 –PCI (ENTER) for the HS7059EPH62H
2. PC card interface (HS6000EIP01H)
 - > TM7058 –PCCD (ENTER) for the HS7058EPH62H
 - > TM7059 –PCCD (ENTER) for the HS7059EPH62H
3. LAN adapter (HS6000ELN01H)
 - > TM7058 –ELN (ENTER) for the HS7058EPH62H
 - > TM7059 –ELN (ENTER) for the HS7059EPH62H
4. USB adapter (HS6000EIU01H or HS6000EIU02H)
 - > TM7058 –USB (ENTER) for the HS7058EPH62H
 - > TM7059 –USB (ENTER) for the HS7059EPH62H

The High-performance Embedded Workshop must be installed before the test program is executed.

Be sure to initiate the diagnostic program from <Drive>:\Diag\HS7058EPH60H. Do not initiate it from a directory other than <Drive>:\Diag\HS7058EPH60H, such as <Drive>:\Diag\HS7058EPH62H\TM7058 –PCI (ENTER). If the diagnostic program is initiated when the current directory is not <Drive>:\Diag\HS7058EPH62H, the diagnostic program will not operate correctly.

When –S is added to the command line such as > TM7058 –PCI –S (ENTER), steps 1 to 13 will be repeatedly executed. To stop the execution, enter Q. The procedure is the same as using the HS7059EPH62H, for this case replace the "7058" to "7059".

- Notes:
1. <Drive> is a drive name for the CD-ROM drive.
 2. Do not remove the CD-R from the CD-ROM drive during test program execution.

The following messages are displayed during the test. There are 13 steps in this test (when a PCI interface board is used, the time for the test will be about three minutes).

The following is an example of message for the HS7058EPH62H.

Message	Description
SH7058 E6000H Emulator Tests Vx.x.xx	Test program start message. xx shows the version number.
Loading driverOK (Use PCI)	Shows that the PC interface board is correctly installed in the host computer.
Initializing driverOK	Shows that the E6000H emulator is correctly connected to the host computer.
Searching for interface cardOK	
Checking emulator is connectedOK	
Emulator board information: Main board ID: H'0 Emulation board ID: H'001	Shows the ID number of the E6000H emulator.
Normal started at Tue Oct 07 16:52:05 2003	Shows the time when the diagnostic program has started.
***** NORMAL TEST - Press 'Q' to stop *****	(COUNT=0001)
1. Main Board Access	
01) Registers Initial Value CheckOK	
02) Registers Write/VerifyOK	
03) DPRAM Address Decode TestSKIP	
04) DPRAM Marching TestSKIP	
05) Trace Memory Address Decode TestOK	
06) Trace Memory Marching TestOK	
07) G/A Registers Initial Value CheckOK	
08) G/A Registers Write/VerifyOK	
2. Emulation Board Access	
01) Registers Initial Value CheckOK	
02) Registers Write/VerifyOK	
03) H-UDI Interface Registers Initial Value CheckOK	
04) H-UDI Interface Registers Write/VerifyOK	
05) AUD Interface Registers Initial Value CheckOK	
06) AUD Interface Registers Write/Verify.....OK	
07) AUD Interface Registers Address Decode TestOK	
08) PCKCR Registers Bit Test.....OK	
3. Evaluation Board Access	
01) Registers Initial Value CheckOK	
02) Registers Write/VerifyOK	
03) H-UDI IDCODE CheckOK	
04) Firmware BOOTOK	
05) Configuration SetOK	

- 4. Basic Function
 - 01) GO to BREAKOK
 - 02) RESET GOOK
 - 03) STEPOK
 - 04) KEYBREAKOK
 - 05) BRKCONTOK
 - 06) Internal ROM TestOK
 - 07) Internal RAM TestOK
- 5. GO to BREAK Time Measurement
 - 01) Counter Test ModeOK
 - 02) EMU 5MHz MPU 20MHz Sampling 20ns (Default)OK
 - 03) EMU 5MHz MPU 20MHz Sampling 1.6usOK
 - 04) EMU 5MHz MPU 20MHz Sampling 52usOK
 - 05) EMU 10MHz MPU 40MHz Sampling MPUOK
 - 06) EMU 10MHz MPU 40MHz Sampling MPU/2OK
 - 07) EMU 10MHz MPU 40MHz Sampling MPU/4OK
 - 08) EMU 5MHz MPU 20MHz Sampling 20nsOK
 - 09) EMU 10MHz MPU 80MHz Sampling 20nsOK
- 6. Emulation Monitor
 - 01) AUDRESOK
 - 02) TRESOK
 - 03) AEST1 - 0OK
 - 04) VCC3VNGOK
 - 05) VCC2-5VNGOK
 - 06) VCC1-NGOK
- 7. G/A Break Function
 - 01) Address ConditionOK
 - 02) Data ConditionOK
 - 03) Control Signal Condition (ASEDSHH/HL/LH/HL)OK
 - 04) Function Code Condition (ASEBM1 ASESAS2-0)OK
 - 05) Control Signal Condition (ASEAS2-1)OK
 - 06) Control Signal Condition (ASEIF-N)OK
 - 07) Control Signal Condition (ASEERAM-N)OK
 - 08) Control Signal Condition (/DMA_AUD AEBM0)OK
 - 09) Control Signal Condition (AEST1-0)OK
- 8. G/A Performance Analysis Function
 - 01) Time Measurement (20ns Sampling)OK
- 9. G/A Monitor Function
 - 01) STEP/RUNOK
 - 02) VCCDOWNOK
 - 03) NOCLKOK
 - 04) TIMEOUTOK

10. G/A Parallel RAM Monitor
- 01) PRAM Monitor (BYTE)OK
 - 02) PRAM Monitor (WORD)OK
 - 03) PRAM Monitor (LONG WORD)OK
11. G/A Trace Function
- 01) Free TraceOK
 - 02) Trace StopOK
 - 03) Time StampOK
 - 04) Trace SuppressOK
12. Combination
- 01) B to A Time Measurement(FPGA counter)OK
 - 02) B to A Time Measurement(G/A counter)OK
 - 03) D to C Time Measurement(G/A counter)OK
13. Parallel Access
- 01) AUD Write (INROM BYTE)OK
 - 02) AUD Write (INROM WORD)OK
 - 03) AUD Write (INROM LONGWORD)OK
 - 04) AUD Write (INRAM BYTE)OK
 - 05) AUD Write (INRAM WORD)OK
 - 06) AUD Write (INRAM LONGWORD)OK
 - 07) AUD Sample (INROM BYTE)OK
 - 08) AUD Sample (INROM WORD)OK
 - 09) AUD Sample (INROM LONGWORD)OK
 - 10) AUD Sample (INRAM BYTE)OK
 - 11) AUD Sample (INRAM WORD)OK
 - 12) AUD Sample (INRAM LONGWORD)OK
 - 13) AUD Sample 256pointOK

Normal stopped at Tue Oct 07 16:54:23 2003

Shows the time when the diagnostic program has ended.

Tests run for 0h:2min:18s

Shows the execution time of the diagnostic program.

Summary:

Tests performed 1 time(s).

1. Main Board Access	: 0 Error(s)
2. Emulation Board Access	: 0 Error(s)
3. Evaluation Board Access	: 0 Error(s)
4. Basic Function	: 0 Error(s)
5. GO to BREAK Time Measurement	: 0 Error(s)
6. Emulation Monitor	: 0 Error(s)
7. G/A Break Function	: 0 Error(s)
8. G/A Performance Analysis Function	: 0 Error(s)
9. G/A Monitor Function	: 0 Error(s)
10. G/A Parallel RAM Monitor	: 0 Error(s)
11. G/A Trace Function	: 0 Error(s)
12. Combination	: 0 Error(s)
13. Parallel Access	: 0 Error(s)

Shows the total of the number of errors occurred in each test item.

4.4 Repair Request Sheet

Thank you for purchasing the E6000H emulator (HS7058EPH62H / HS7059EPH62H).

In the event of a malfunction, fill in the repair request sheet on the following pages and send it to your distributor.

Repair Request Sheet

To Distributor

Your company name:

Person in charge:

Tel.:

Item	Symptom
1. Date and time when the malfunction occurred	Month/Day/Year {at system initiation, in system operation} *Circle either of items in the braces { }.
2. Frequency of generation of the malfunction	() times in () {day(s), week(s), or month(s)} *Enter the appropriate numbers in the parentheses () and circle one of the three items in the braces { }.
3. System configuration when the malfunction occurred	<p>System configuration of the emulator:</p> <ul style="list-style-type: none"> • E6000H emulator (HS7058EPH62H / HS7059EPH62H): Serial No.: Revision: The above items are written on the label for product management at the bottom of the emulator unit; the serial no. is the four-digit number and the revision is the string of letters following the number. • Host interface: PCI interface board { HS6000EIC01H, EHS6000EIC02H} PC card interface { HS6000EIP01H} LAN adaptor { HS6000ELN01H} USB adaptor { HS6000EIU01H, EHS6000EIU02H} Serial No.: Revision: (Indicated on the board) • Provided CD-R (HS7058EPH60SR): Version: V. Shown as 'V.x.xx Release xx' on the CD-R (x: numeral). • Host computer in use: Manufacturer: Type number: OS: (Windows®98SE, Windows® Me, WindowsNT®4.0, Windows®2000, or Windows®XP) Connection of the actual device: { Yes or No} User system interface board: { Available or Not available} MCU: Type number:

Item	Symptom
4. Settings when the malfunction occurred	(1)Operation mode: Mode (2)Voltage of the target system: V (3)Clock in use: (input from emulator internal clock, Xtal oscillation, or external clock) –circle one item. (4) Operating frequency: MHz
5. Failure phenomenon	
6. Error in debugging	
7. Error in the diagnostic program	
8. The High-performance Embedded Workshop does not link-up with the emulator.	Content of the error message

For errors other than the above, fill in the box below.

--

Debugger Part

Section 1 Overview

The Debugger Part includes the following information.

Table 1.1 Debugger Part Contents

Section	Title	Content
2	Preparation before Use	This section starts with creation of a workspace and ends with connection to the emulator.
3	Debugging	<p>This section describes this emulator 's peculiar debugging operation and the associated windows and dialog boxes.</p> <p>Refer to the High-performance Embedded Workshop user's manual about High-performance Embedded Workshop common functions as below.</p> <ul style="list-style-type: none"> — Preparations for Debugging — Viewing a Program — Operating Memory — Displaying Memory Contents as Waveforms — Displaying Memory Contents as an Image — Modifying the variables — Viewing the I/O Memory — Looking at Registers — Executing Your Program — Viewing the Function Call History — Debugging with the Command Line Interface — Elf/Dwarf2 Support — Looking at Labels
4	Tutorial	This section describes how to use the emulator functions by using a tutorial program provided with the emulator.
5	Software Specifications and Notes Specific to This Product	This section describes software specifications and notes regarding the emulator.
6	Error Messages	This section describes the contents of error messages that may occur while the emulator is in use, and solutions to them.

Section 2 Preparation before Use

2.1 Method for Activating High-performance Embedded Workshop

To activate the High-performance Embedded Workshop, follow the procedure listed below.

1. Connect the emulator to the host computer.
2. Connect the user system interface cable to the connector of the emulator if you use the user system interface cable. This is not necessary when you do not use the user system interface cable.
Turn on the emulator. Be sure to turn on the user system before supplying power to the emulator if you use the user system.
3. Activate the High-performance Embedded Workshop from [Programs] in the [Start] menu.
4. The [Welcome!] dialog box is displayed.

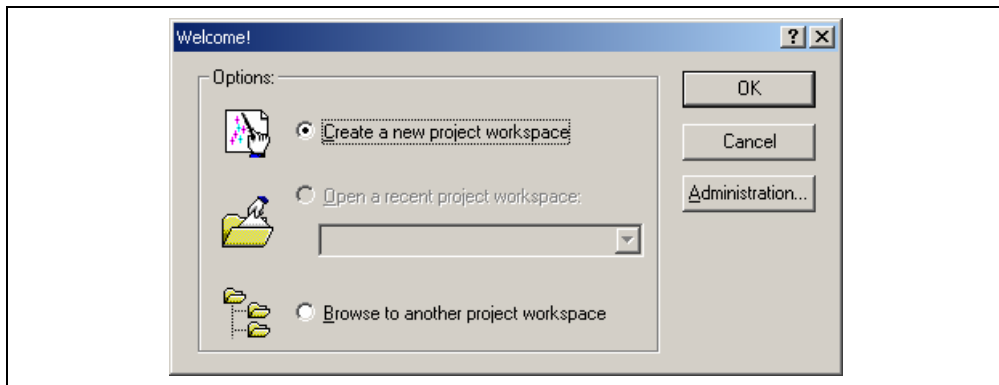

Figure 2.1 [Welcome!] Dialog Box

[Create a new project workspace] radio button: Creates a new workspace.

[Open a recent project workspace] radio button: Uses an existing workspace and displays the history of the opened workspace.

[Browse to another project workspace] radio button: Uses an existing workspace; this radio button is used when the history of the opened workspace does not remain.

In this section, we describe the following three ways to start up the High-performance Embedded Workshop:

- [Create a new project workspace] - a toolchain is not in use
- [Create a new project workspace] - a toolchain is in use
- [Browse to another project workspace]

The method to create a new workspace depends on whether a toolchain is or is not in use. Note that this emulator product does not include a toolchain. Use of a toolchain is available in an environment where the H8S, H8/300 series C/C++ compiler package or the SuperH™ RISC engine C/C++ compiler package has been installed. For details on this, refer to the manual attached to the H8S, H8/300 series C/C++ compiler package or the SuperH™ RISC engine C/C++ compiler package.

2.1.1 Creating a New Workspace (Toolchain Not Used)

1. In the [Welcome!] dialog box that is displayed when the High-performance Embedded Workshop is activated, select [Create a new project workspace] radio button and click the [OK] button.

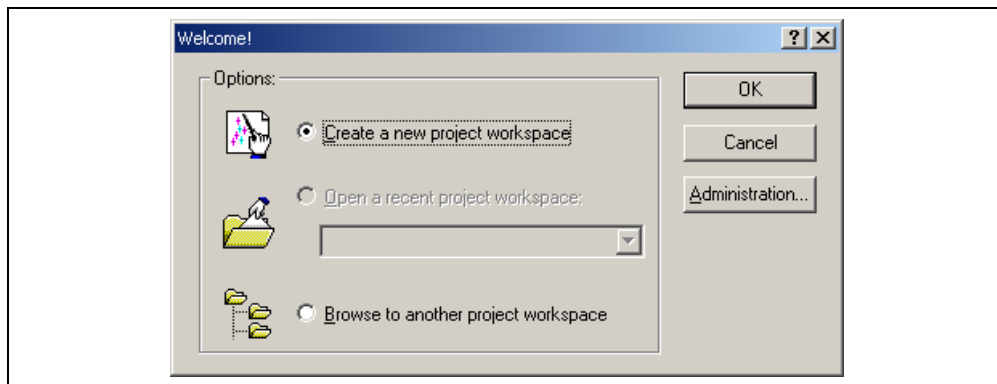

Figure 2.2 [Welcome!] Dialog Box

2. Creation of a new workspace is started. The following dialog box is displayed.

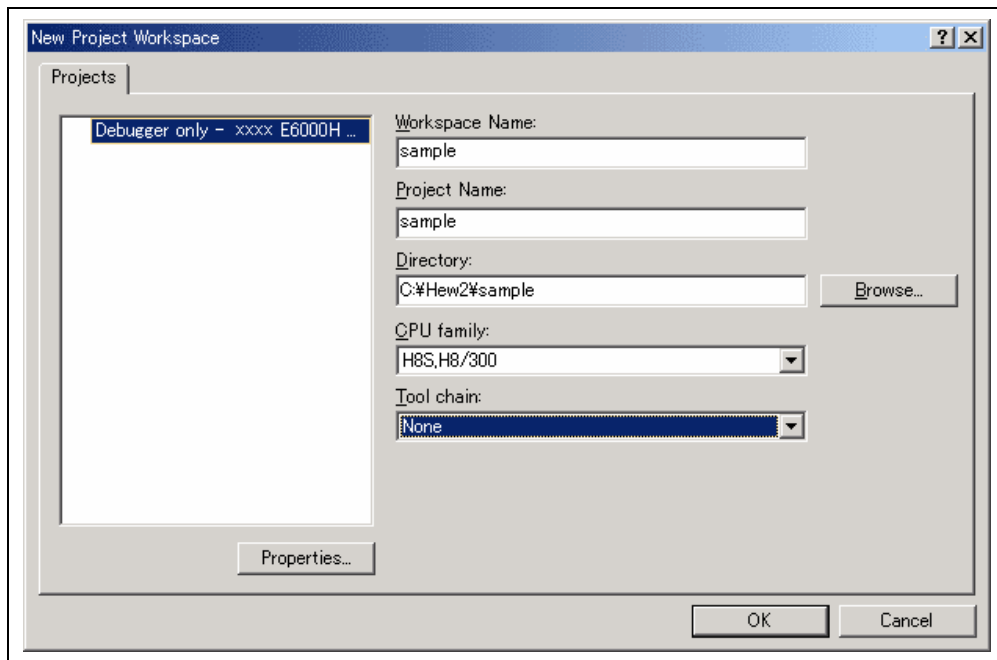

Figure 2.3 [New Project Workspace] Dialog Box

[Workspace Name] edit box: Enter the new workspace name.

[Project Name] edit box: Enter the project name. When the project name is the same as the workspace name, it needs not be entered.

[Directory] edit box: Enter the directory name in which the workspace will be created. Click the [Browse...] button to select a directory.

[CPU family] combo box: Select the target CPU family.

Other list boxes are used for setting the toolchain; the fixed information is displayed when the toolchain has not been installed.

Click the [OK] button.

3. Select the target platform of the session file. The following dialog box is displayed.

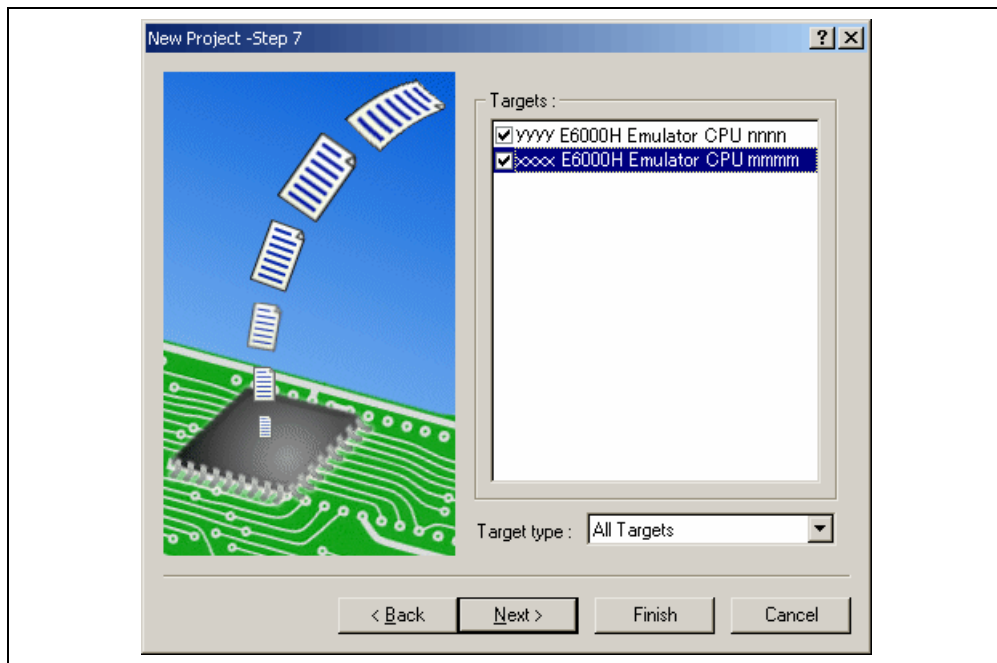

Figure 2.4 [New Project – Step 7] Dialog Box

The target platform for the session file used when the High-performance Embedded Workshop is activated must be selected here. Check the box against the target platform and then click the [Next] button.

4. Set the configuration file name. The configuration file saves the state of High-performance Embedded Workshop except for the emulator.

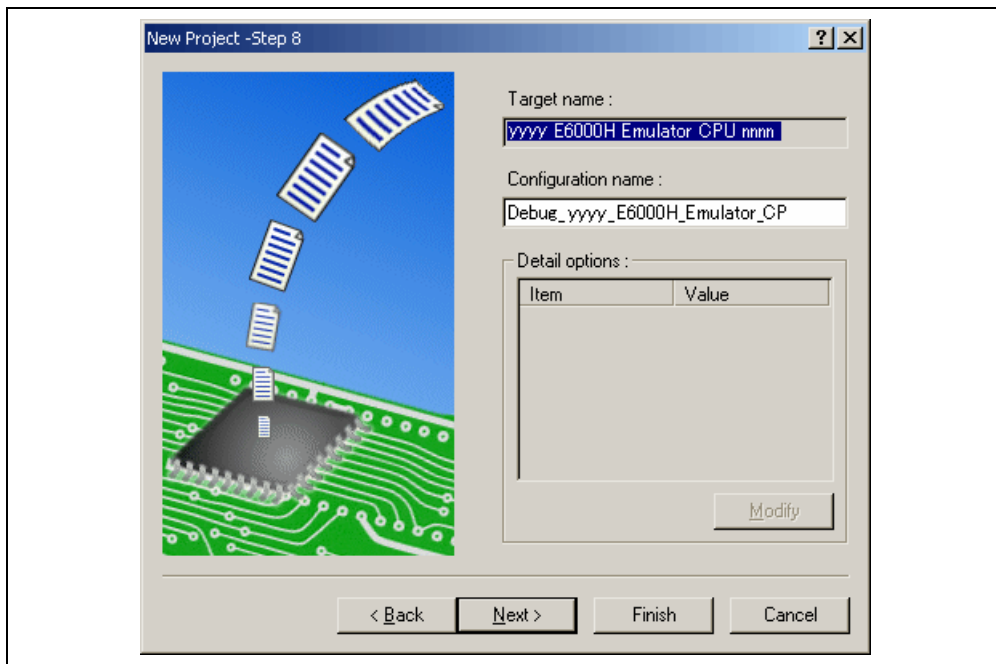

Figure 2.5 [New Project – Step 8] Dialog Box

If multiple target platforms were selected in the [New Project – Step 7] dialog box shown in figure 2.5, set the name of a configuration file for each of them, each time clicking the [Next] button to proceed to the next target.

Setting of the configuration file name is the end of the emulator settings.

Click the [Finish] button to display the [Summary] dialog box. Clicking the [OK] button activates the High-performance Embedded Workshop.

5. After the High-performance Embedded Workshop has been activated, the emulator is automatically connected. The message “Connected” is displayed on the [Debug] tab in the [Output] window to indicate the completion of connection.

2.1.2 Creating a New Workspace (Toolchain Used)

1. In the [Welcome!] dialog box that is displayed when the High-performance Embedded Workshop is activated, select the [Create a new project workspace] radio button and click the [OK] button.

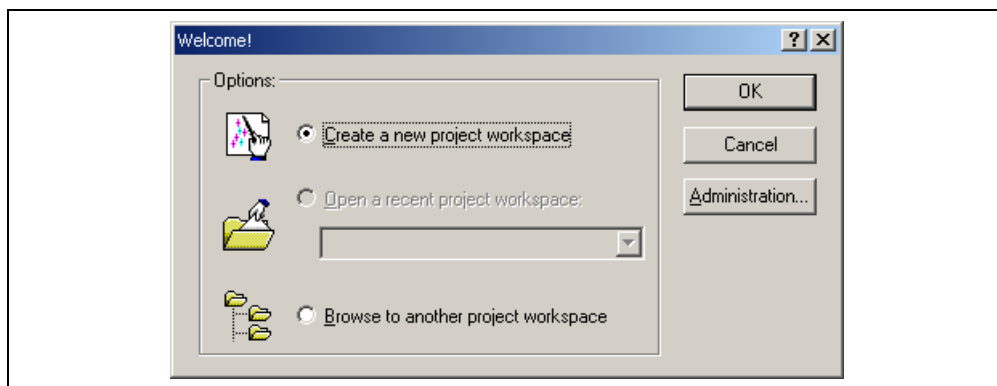

Figure 2.6 [Welcome!] Dialog Box

2. Creation of a new workspace is started. The following dialog box is displayed.

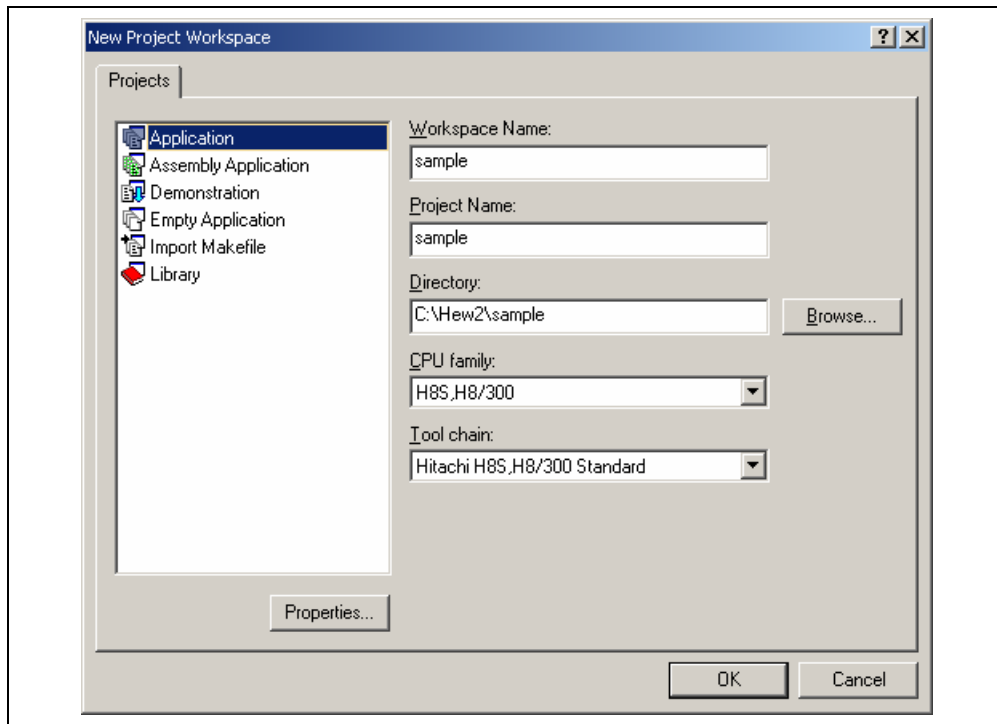

Figure 2.7 [New Project Workspace] Dialog Box

[Workspace Name] edit box: Enter the new workspace name.

[Project Name] edit box: Enter the project name. When the project name is the same as the workspace name, it needs not be entered.

[Directory] edit box: Enter the directory name in which the workspace will be created. Click the [Browse...] button to select a directory.

[CPU family] combo box: Select the target CPU family.

[Tool chain] combo box: Select the target toolchain name when using the toolchain. Otherwise, select [None].

[Project type] list box: Select the project type to be used.

Notes: When [Demonstration] is selected in the emulator, note the followings:

The [Demonstration] is a program for the simulator attached to the H8S, H8/300 compiler package or the SuperH™ RISC engine C/C++ compiler package. To use the generated source file, delete the printf statement in the source file.

3. Make the required setting for the toolchain. When the setting has been completed, the following dialog box is displayed.

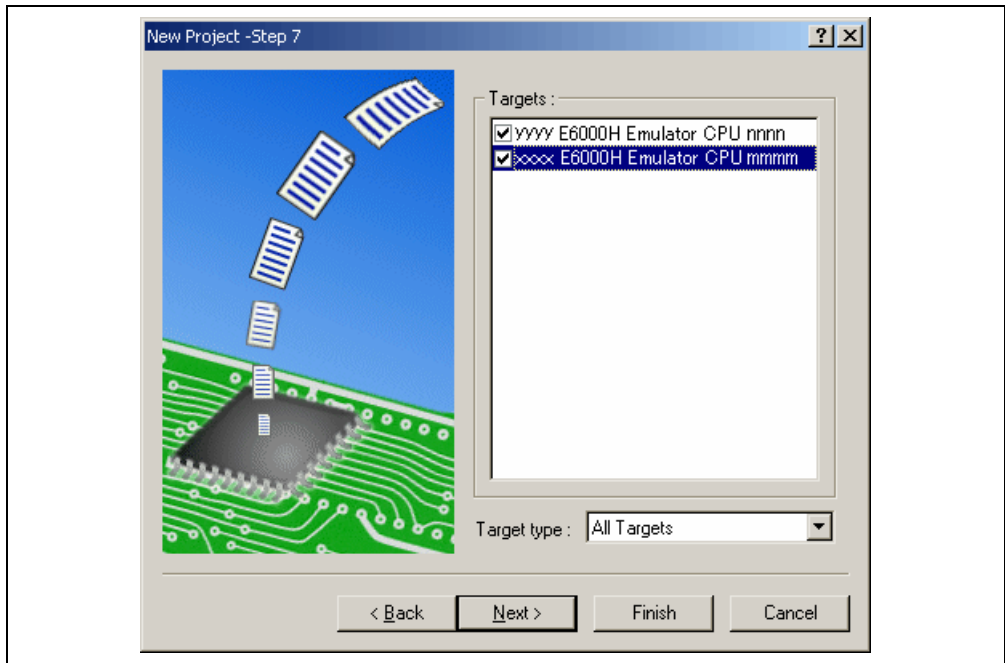

Figure 2.8 [New Project – Step 7] Dialog Box

The target platform for the session file used when the High-performance Embedded Workshop is activated must be selected here. Check the box against the target platform and then click the [Next] button.

- Set the configuration file name. The configuration file saves the state of High-performance Embedded Workshop except for the emulator.

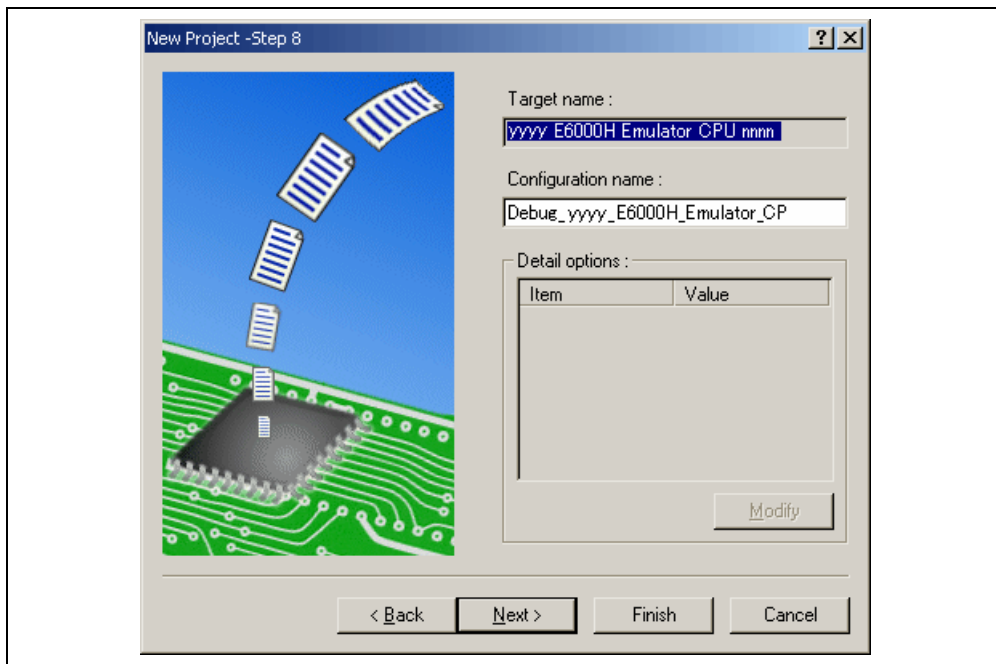

Figure 2.9 [New Project – Step 8] Dialog Box

If multiple target platforms were selected in the [New Project – Step 7] dialog box shown in figure 2.9, set the configuration file name for each of them, each time clicking the [Next] button to proceed to the next target.

Setting of the configuration file name is the end of the emulator settings.

Complete the creation of a new workspace according to the instructions on the screen. This activates the High-performance Embedded Workshop.

- After the High-performance Embedded Workshop has been activated, connect the emulator. However, it is not necessary to connect the emulator immediately after the High-performance Embedded Workshop has been activated.

Select either of the following two ways to connect the emulator: connecting the emulator after the setting at emulator activation or without the setting at emulator activation. For details on the connection of the emulator, refer to section 2.2, Connecting the Emulator.

2.1.3 Selecting an Existing Workspace

1. In the [Welcome!] dialog box that is displayed when the High-performance Embedded Workshop is activated, select [Browse to another project workspace] radio button and click the [OK] button.

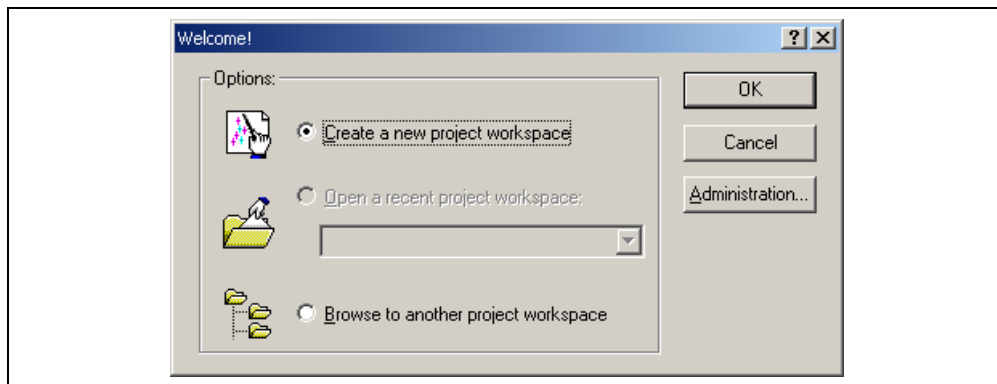

Figure 2.10 [Welcome!] Dialog Box

2. The [Open Workspace] dialog box is displayed. Select a directory in which you have created a workspace. After that, select the workspace file (.hws) and click the [Open] button.

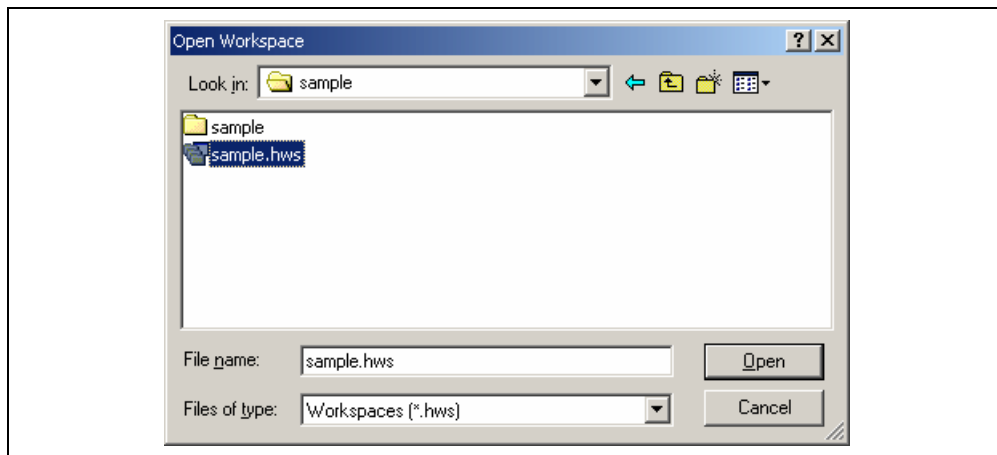

Figure 2.11 [Open Workspace] Dialog Box

3. This activates the High-performance Embedded Workshop and recovers the state of the selected workspace at the time it was saved.
When the saved state information of the selected workspace includes connection to the emulator, the emulator will automatically be connected. To connect the emulator when the saved state information does not include connection to the emulator, refer to section 2.2, Connecting the Emulator.

2.2 Connecting the Emulator

Select either of the following two ways to connect the emulator:

- (a) Connecting the emulator after the setting at emulator activation

Select [Debug -> Debug Settings...] to open the [Debug Settings] dialog box. It is possible to register the download module or the command chain that is automatically executed at activation.

When the dialog box is closed after setting the [Debug Settings] dialog box, the emulator will automatically be connected.

- (b) Connecting the emulator without the setting at emulator activation

Connect the emulator by simply switching the session file to one in which the setting for the emulator use has been registered.

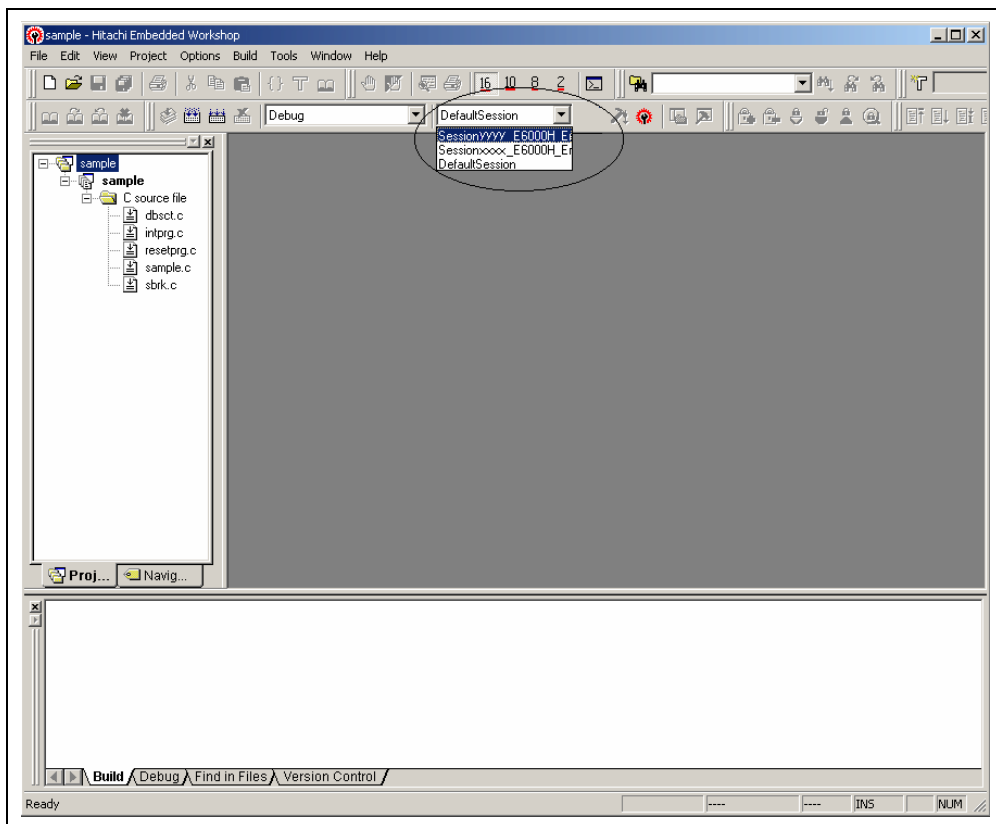



Figure 2.12 Selecting the Session File

In the list box that is circled in figure 2.12, select the session file name including the character string that has been set in the [Target name] text box in figure 2.9, [New Project – Step 8] dialog box. The setting for using the emulator has been registered in this session file.

Selecting [Debug -> Connect] connects the emulator.

2.3 Re-connecting the Emulator

When the emulator is disconnected, re-connection is possible by using the following methods.

Select [Debug -> Connect] or click the [Connect] toolbar button () to re-connect the emulator.

Note: When re-connecting the emulator, the load module must be registered to the High-performance Embedded Workshop beforehand.

2.4 Ending the Emulator

The emulator can be exited by using the following two methods:

(a) Canceling the connection of the emulator being activated

Select [Debug -> Disconnect] or click on the [Disconnect] toolbar button ()

(b) Exiting the High-performance Embedded Workshop

1. Select [File -> Exit].

2. A message box is displayed. If necessary, click the [Yes] button to save a session. After saving a session, the High-performance Embedded Workshop exits.

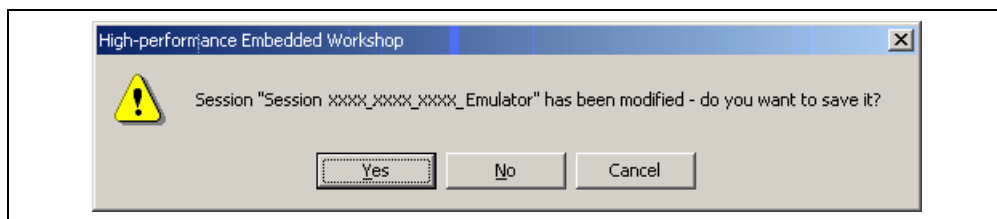

Figure 2.13 [Session has been modified] Message Box

Section 3 Debugging

This section describes the debugging operations and their related windows and dialog boxes.

3.1 Setting the Environment for Emulation

The method for setting the environment for emulation is described here. This environment must be set correctly before debugging is started.

3.1.1 Opening the [Configuration Properties] Dialog Box

Selecting [Setup -> Emulator -> System...] or clicking the [Emulator System] toolbar button  opens the [Configuration Properties] dialog box.

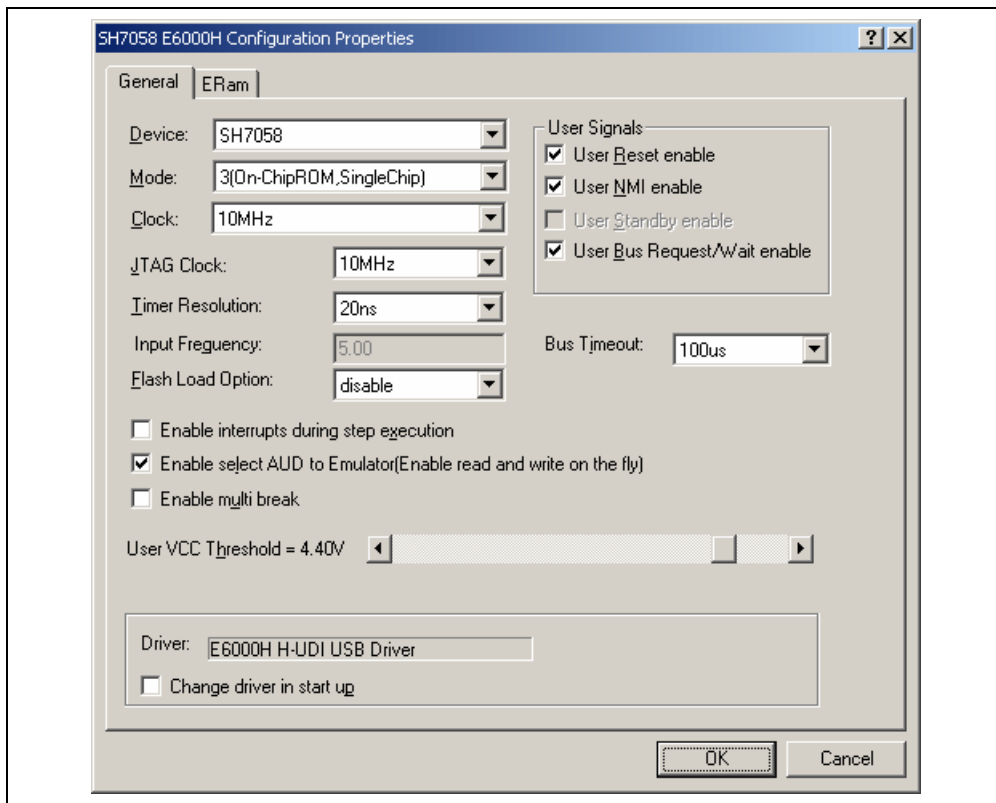

Figure 3.1 [Configuration Properties] Dialog Box ([General] Page)

[General] page

[Device]	Selects the target MCU to be emulated. See the hardware manual for details.
[Mode]	Selects the operating mode for emulation. There are the following five modes. 0: 8-bit bus 1: 16-bit bus 2: On-chip ROM enabled 3: On-chip ROM enabled, single chip Target: Mode that has been set on the user system
[Clock]	Selects the clock to be supplied to the MCU. Target: Clock signal for the user system Xtal: Crystal oscillator on the evaluation chip board xMHz: Internal clock (When HS7058EPH62H is used: x = 5 or 10 When HS7059EPH62H is used: x = 5, 6, 8 or 10)
[JTAG Clock]	Selects the JTAG clock. When HS7058EPH62H is used: 10, 15, or 20(MHz) When HS7059EPH62H is used: 5, 6, 8, 10, 12, 12.5, 15, 18 or 20(MHz)
[Timer Resolution]	Selects the timer resolution for use in execution time measurement and performance analysis. Select one of the following values. Execution time measurement: 52 us, 1.6 us, or 20 ns Clock counter measurement: CLOCK, CLOCK/2, CLOCK/4, or CLOCK/8
[Input Frequency]	Selects the clock to be supplied to the MCU. Set the frequency of Xtal or Target that has been specified for [Clock]. The value must be input to two decimal places between 5.00 MHz to 10.00 MHz (by rounding off to two decimal places). This frequency is used for programming the on-chip flash memory.
[Flash Load Option]	Sets the operation when programming the on-chip flash memory. disable: Programming disabled. The on-chip flash memory is not programmed even if loading of a program is attempted. update: Programs the on-chip flash memory without initialization erase: Initializes and programs the on-chip flash memory of the target block all erase: Initializes and programs the entire on-chip flash memory
[Enable interrupts during step execution]	When this box is checked, interrupts are accepted during step execution.
[Enable select AUD to Emulator (Enable read and write on the fly)]	When this box is checked, the AUD is used by the emulator. It is possible to view or modify the contents of memory during user program execution.
[Enable multi break]	When this box is checked, the multibreak function is enabled. The multibreak function allows a break to occur in several E6000H emulators by using a trigger input and probe pins.
[User VCC Threshold]	Sets the voltage level for the user system. [Down] will be displayed in [User PVCC1] of the [Extended Monitor] window when the actual user VCC of the target system is lower than the specified value. When the operating mode is changed, the voltage level will be set to the initial value of the new operating mode.
[User Signals]	When this group box is checked, input of the corresponding control pins are enabled.
[Bus Timeout]	Select the bus timeout detection time. 100us, 1.6ms, 13ms, or 210ms can be selected.

[General] page (cont)

[Driver]	Displays the E6000H driver that is currently installed.
[Change driver in start up]	When this box is checked, selection of a driver will be available next time the emulator is connected.

Notes: 1. The system clock (ϕ) is set as the input for the clock counter setting.
 2. The emulator realizes a parallel access by using the AUD function. When [Enable select AUD to Emulator (Enable read and write on the fly)] is unchecked and the AUD function is used by the user, memory access is disabled during user program execution.

(1) Change of the Operating Mode

Changing the operating mode releases the settings made regarding the ERAM or software breaks and resets the CPU. If the mode selected in the user system is incorrect while [Target] is selected, an error is displayed. Select an appropriate mode.

(2) Clock supplied to the MCU

Check the followings when you select a clock:

- Before selecting Target, ensure that the user system is supplied with power. Otherwise, an error appears after [OK] is pressed.
- Before selecting Xtal, ensure that the crystal oscillator is installed into the crystal oscillator terminals on the evaluation chip board. Otherwise, the operation will be incorrect.
- Changing the clock resets the target MCU.

(3) JTAG Clock

The debugging function in the E6000H emulator is realized by serial communication with the target MCU. The JTAG clock is used as the input clock in this serial communication. Set the JTAG clock frequency as high as possible to improve performance in downloading and reading memory. Note that, however, the JTAG clock frequency must be lower than that of the peripheral modules clock ($P\phi$) of the target MCU.

3.1.2 Using the Emulation RAM

Use the [ERam] page of the [Configuration Properties] dialog box to make settings for the emulation RAM. 16 and 24 blocks of 16-kbyte units are available in the emulation RAM of HS7058EPH62H and HS7059EPH62H, respectively. The addresses of the emulation RAM can overlap with those of the on-chip flash memory. Use of the emulation RAM allows debugging without overwriting a program or data in the on-chip flash memory. The emulation RAM can also be used as an on-chip RAM for debugging while not used in the emulator.

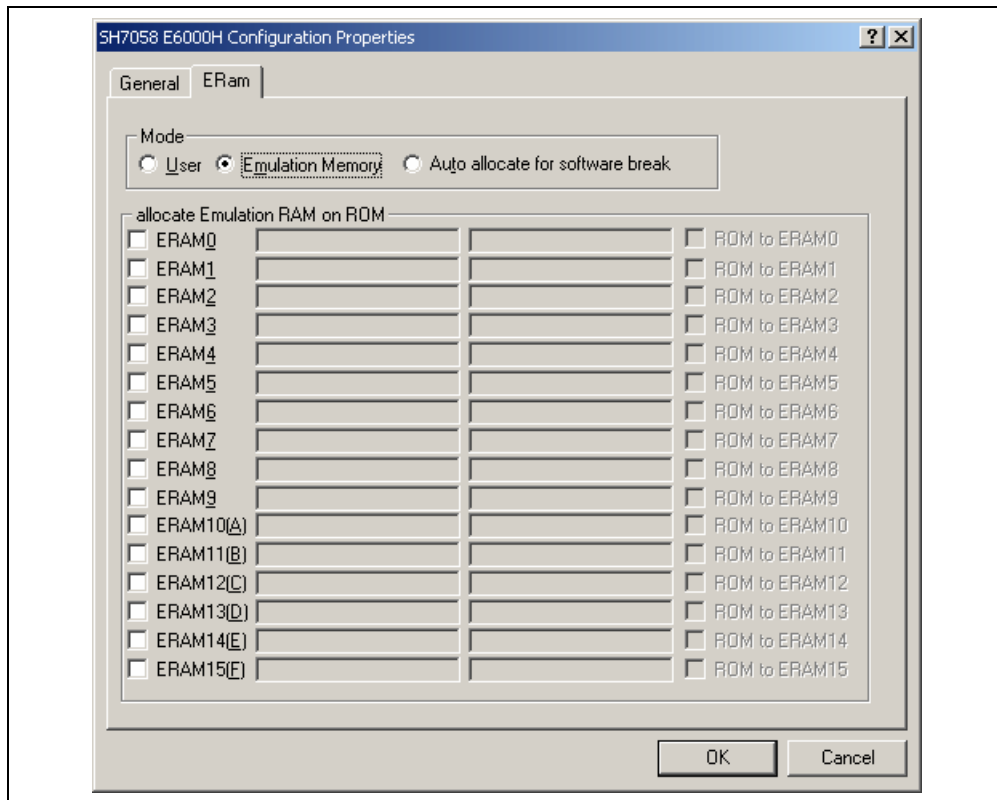

Figure 3.2 [Configuration] Dialog Box ([ERam] Page)

[ERam] page

[Mode]	[User]	The emulation RAM is not used in the emulator.
	[Emulation Memory]	The emulation RAM is used in the emulator. [allocate Emulation RAM on ROM] allows allocation of addresses overlapped with those of the on-chip flash memory.
[Auto allocate for software break]	The emulation RAM is used in the emulator and automatically allocated when a software break is being set on the on-chip flash memory.	
[allocate Emulation RAM on ROM]	First checkbox	<p>Checking this box allocates the emulation RAM to the on-chip flash memory address specified in the right-hand field. Pressing the [OK] button after removing a check mark in this box displays the message “Do you copy ERAMn memory to flash memory?”. Clicking “Yes” starts programming the content of the emulation RAM into the on-chip flash memory, except in the following cases;</p> <ul style="list-style-type: none"> • [Emulation Memory] has been changed to [User] in [Mode] • The ERAM mode has been changed from [Auto allocate for software break] to [User] • The system is terminated <p>When an error has occurred while programming to the on-chip flash memory, the message “Flash Memory Access Error” is displayed and the dialog box is opened again. Check the settings and click the [OK] button.</p>
	Address input	Enter the start address of an allocation area. The next field displays the range for allocation. When a value is set outside the 16-kbyte boundary, the value below the boundary will be rounded to the nearest value.
	Last checkbox	Checking this box reads the content of the on-chip flash memory and then writes it to the emulation RAM when the emulation RAM is allocated. When the user program is downloaded to the on-chip flash memory in this state, the program is also downloaded to the emulation RAM.

- Notes: 1. Software break set on the emulation RAM will not function if use of the emulation RAM is cancelled. Changing the operation mode cancels the emulation RAM settings.
2. Stop the DMAC operation when the emulation memory is set.

Using the Emulation RAM as an On-Chip RAM for Debugging

To use the emulation RAM as an on-chip RAM for debugging, select [User] in [Mode]. Addresses available as an on-chip RAM for debugging are H'FFFB 0000 to H'FFFE FFFF. The emulation RAM is an exclusive function for the emulator. Note that this address area is reserved in the target MCU product.

3.1.3 Selecting the Interface to be Connected

Checking [Change driver in start up] on the [Configuration Properties] dialog box allows a selection of the driver next time the emulator is connected.

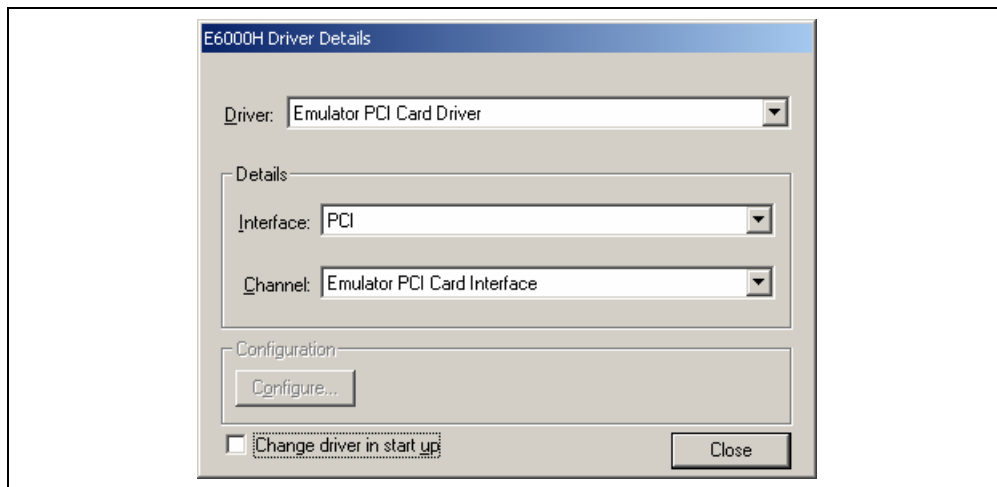

Figure 3.3 [Driver Details] Dialog Box

[Driver]: Selects the driver that connects the High-performance Embedded Workshop and the emulator.

[Details]: Sets the details of the driver being connected.

[Interface]: The name of the interface to be connected. This should not be changed in this emulator.

[Channel]: Channel for the selected interface. This should not be changed in this emulator.

[Configuration]: Driver setting.

[Configure...]: A dialog box for setting will be displayed when the driver supports the configuration dialog. Note that this item is not available with this emulator.

[Change driver in start up]:
Checking this box selects the driver when the emulator is connected the next time.

3.2 Downloading a Program

This section describes how to download a program and view it as source code or assembly-language mnemonics.

Note: After a break has occurred, the [Editor] window displays the location of the present program counter (PC). In most cases, for example if an Elf/Dwarf2-based project is moved from its original path, the source file may not be automatically found. In this case, a source file browser dialog box is displayed to allow you to manually locate the source file.

3.2.1 Downloading a Program

A load module to be debugged must be downloaded.

To download a program, select the load module from [Debug -> Download] or select [Download] from the popup menu opened by clicking the right-hand mouse button on the load module in [Download modules] of the [Workspace] window.

Note: Before downloading a program, it must be registered to the High-performance Embedded Workshop as a load module.

3.2.2 Viewing the Source Code

To view a source file's code, double-click on its icon in the file tree, or right-click on the source file and select the [Open] option on the pop-up menu. The [Editor] window is displayed.

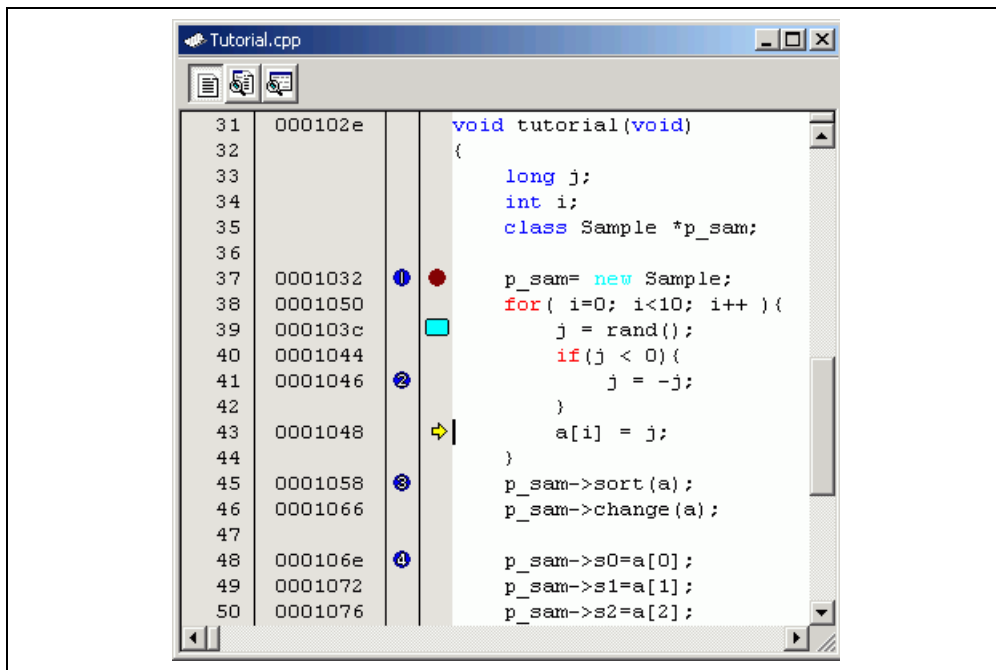

Figure 3.4 Editor Window

In this window, the following items are shown on the left as information on lines.

- 1st column (Line Number column): A line number for the source file
- 2nd column (Source Address column): Address information for the source line
- 3rd column (On Chip Break column): On-chip breaks
- 4th column (S/W Breakpoints column): PC, bookmark, and breakpoint information

The text area is displayed in the right part of the [Editor] window.

Line Number column



This column displays the line number for the source file.

Source Address column

When a program is downloaded, an address for the current source file is displayed on the Source address column. These addresses are helpful when setting the PC value or a breakpoint.

On Chip Break column



The On Chip Break column displays the following items:

-  to : On-chip break channel 1 to 12
- : Reset point

These are also set by using the popup menu.

S/W Breakpoints column

This column displays the following items:

- : A bookmark is set.
- : A PC breakpoint is set.
- : PC location

- ☛ To switch off a column in all source files
 1. Click the right-hand mouse button on the [Editor] window or select the [Edit] menu.
 2. Click the [Define Column Format...] menu item.
 3. The [Global Editor Column States] dialog box is displayed.
 4. A check box indicates whether the column is enabled or not. If it is checked, the column is enabled. If the check box is gray, the column is enabled in some files and disabled in others. Deselect the check box of a column you want to switch off.
 5. Click the [OK] button for the new column settings to take effect.

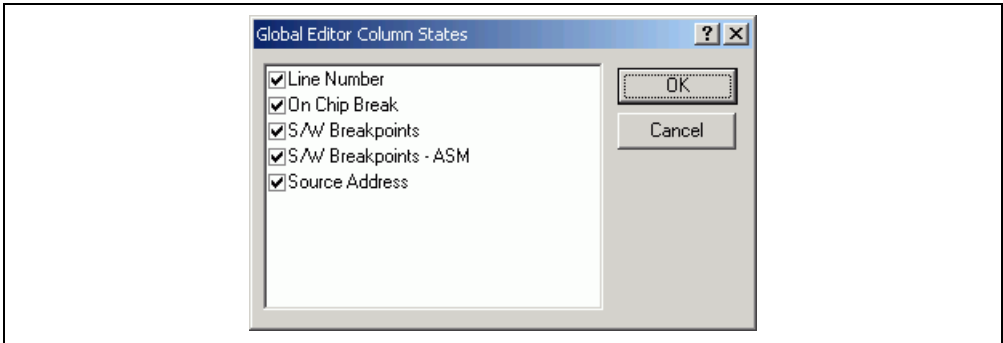

Figure 3.5 [Global Editor Column States] Dialog Box

- ☛ To switch off a column in one source file
 1. Open the source file which contains the column you want to remove and click the [Edit] menu.
 2. Click the [Columns] menu item to display a cascaded menu item. The columns are displayed in this popup menu. If a column is enabled, it has a tick mark next to its name. Clicking the entry will toggle whether the column is displayed or not.

3.2.3 Viewing the Assembly-Language Code

If you have a source file open, right-click to open the pop-up menu and select the [View Disassembly] option to open a Disassembly view at the same address as the current Source view.

It is also possible to view the disassembly using the new integrated [Disassembly view] in the source file.

If you do not have a source file, but wish to view code at assembly-language level, then select one of the following operations:

- Click on the View Disassembly toolbar button .
- Choose the [View -> Disassembly...] menu option.
- Press Ctrl + D.

The [Disassembly] window opens at the current PC location.

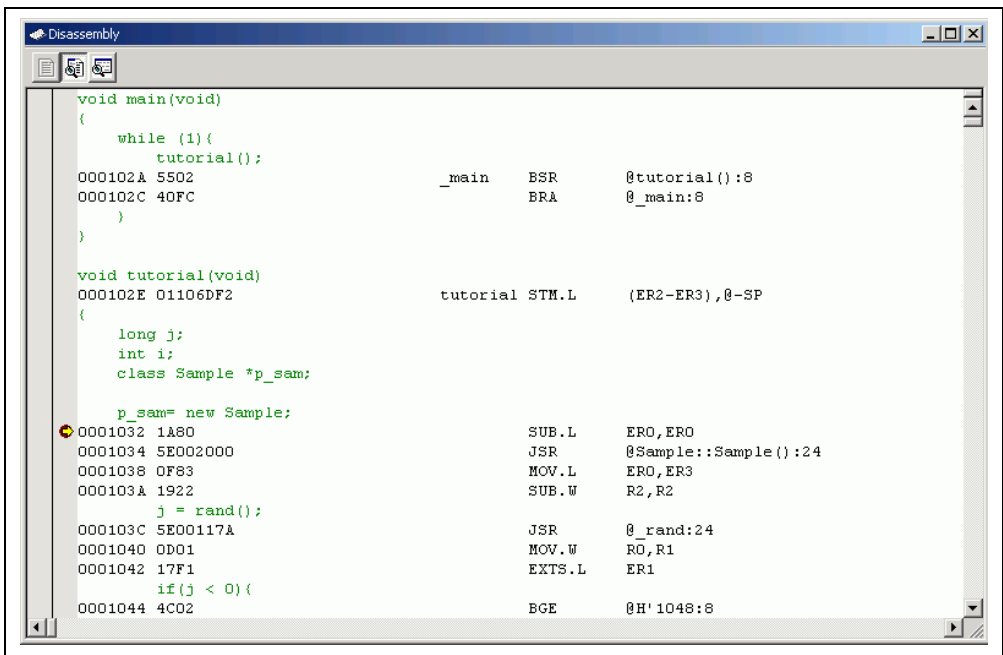

Figure 3.6 [Disassembly] Window

In this window, the following information is shown on the left as information lines.

- First column (On-chip break column): On-chip breaks
- Second column (S/W Breakpoints - ASM column): PC and breakpoint information

This window is used in the same way as the source code window.

3.2.4 Modifying the Assembly-Language Code

You can modify the assembly-language code by double-clicking on the instruction that you want to change. The [Assembler] dialog box will be opened.



Figure 3.7 [Assembler] Dialog Box

The address, instruction code, and mnemonic are displayed. Enter a new instruction or edit the old instruction in the [Mnemonics] field. Pressing the [Enter] key will replace the memory content with the new instruction and move on to the next instruction. Clicking the [OK] button will replace the memory content with the new instruction and close the dialog box. Clicking the [Cancel] button or pressing the [Esc] key will close the dialog box without modifying the memory contents.

Note: The assembly-language code being displayed is the current memory content. If the memory contents are changed the [Assembler] dialog box and the [Disassembly] window will show the new assembly-language code, but the source file displayed in the [Editor] window will be unchanged. This is the same even if the source file contains assembly codes.

3.2.5 Viewing a Specific Address

When you are viewing your program in the [Disassembly] window, you may wish to look at another area of your program's code. Rather than scrolling through a lot of code in the program, you can go directly to a specific address. Select [Set Address...] from the popup menu, and the dialog box shown in figure 3.8 is displayed.

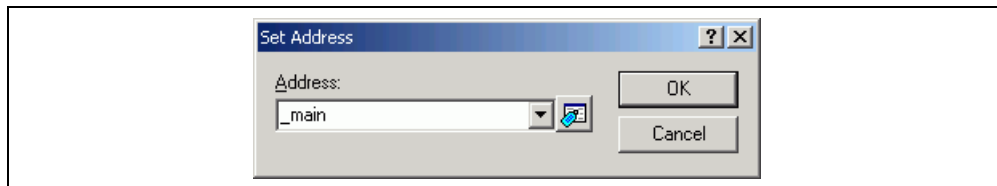



Figure 3.8 [Set Address] Dialog Box

Enter the address in the [Address] edit box and either click on the [OK] button or press the Enter key. A label name can also be specified as the address. When an overloaded function or a class name is entered, the [Select Function] dialog box opens for you to select a function.

3.2.6 Viewing the Current Program Counter Address

Wherever you can enter an address or value into the High-performance Embedded Workshop, you can also enter an expression. If you enter a register name prefixed by the hash character, the contents of that register will be used as the value in the expression. Therefore, if you enter the expression #pc in the [Set Address] dialog box, the [Editor] or [Disassembly] window will display the current PC address. It allows the offset of the current PC to be displayed by entering an expression with the PC register plus an offset, e.g., #PC+0x100.

3.3 Viewing the Current Status

Choose [View -> CPU -> Status] or click the [View Status] toolbar button  to open the [Status] window and see the current status of the debugging platform.

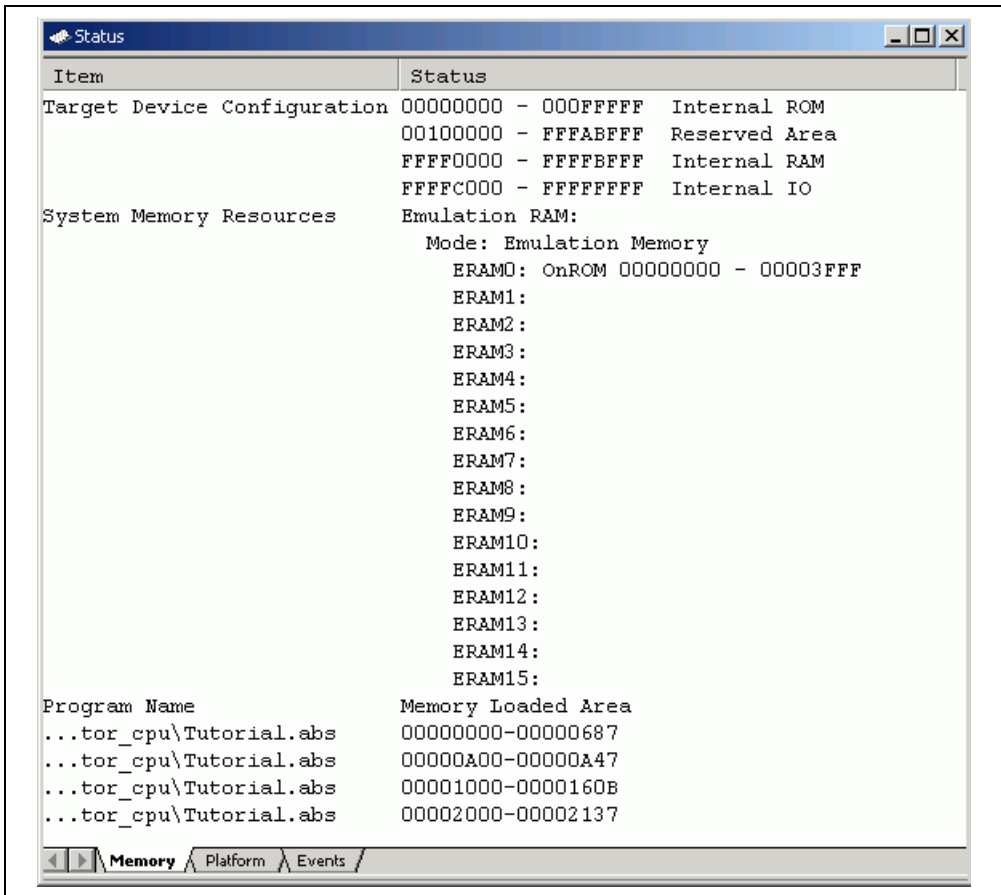

Figure 3.9 [Status] Window

The [Status] window has following three sheets:

- [Memory] sheet
Displays information about the current memory status including the memory mapping resources and the areas used by the currently loaded object file.
- [Platform] sheet
Displays information about the environment for emulation, typically including CPU type and emulation mode.
- [Events] sheet
Displays information about the current event (breakpoint) status, including resource information.

Note: The items that can be set in this window depend on the emulator in use. For details, refer to the online help.

3.4 Reading and Displaying the Emulator Information Regularly

Use the [Extended Monitor] window to know the changing information on the emulator no matter the user program is running or halted.

Note: The extended monitor function does not affect the execution of the user program since it monitors the user system or the signal output from the target MCU in the emulator by using the emulator's hardware circuit.

3.4.1 Opening the [Extended Monitor] Window

Selecting [View -> CPU -> Extended Monitor] or clicking the [Extended Monitor] toolbar button  displays this window. The interval of updating the display is approximately 1,000 ms during user program execution or 5,000 ms while breaking, respectively.

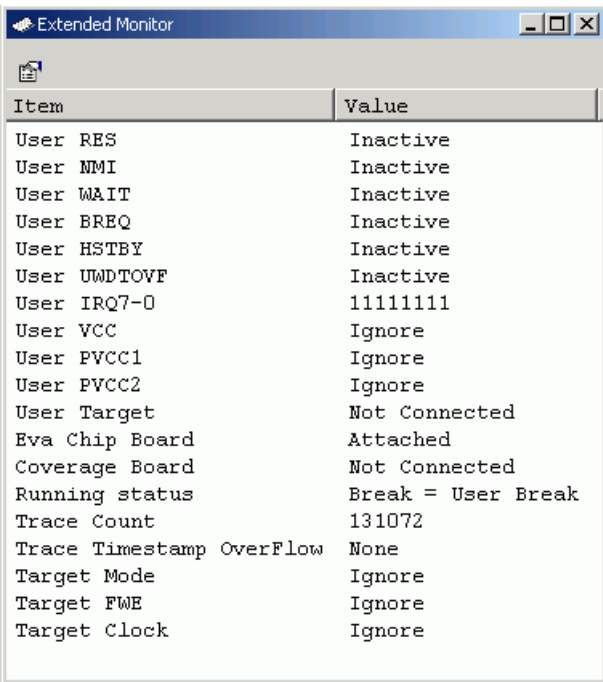

Item	Value
User RES	Inactive
User NMI	Inactive
User WAIT	Inactive
User BREQ	Inactive
User HSTBY	Inactive
User UWDTOVF	Inactive
User IRQ7-0	11111111
User VCC	Ignore
User PVCC1	Ignore
User PVCC2	Ignore
User Target	Not Connected
Eva Chip Board	Attached
Coverage Board	Not Connected
Running status	Break = User Break
Trace Count	131072
Trace Timestamp Overflow	None
Target Mode	Ignore
Target FWE	Ignore
Target Clock	Ignore

Figure 3.10 [Extended Monitor] Window

3.4.2 Selecting Items to be Displayed

Selecting [Properties...] from the popup menu displays the [Extended Monitor Configuration] dialog box.

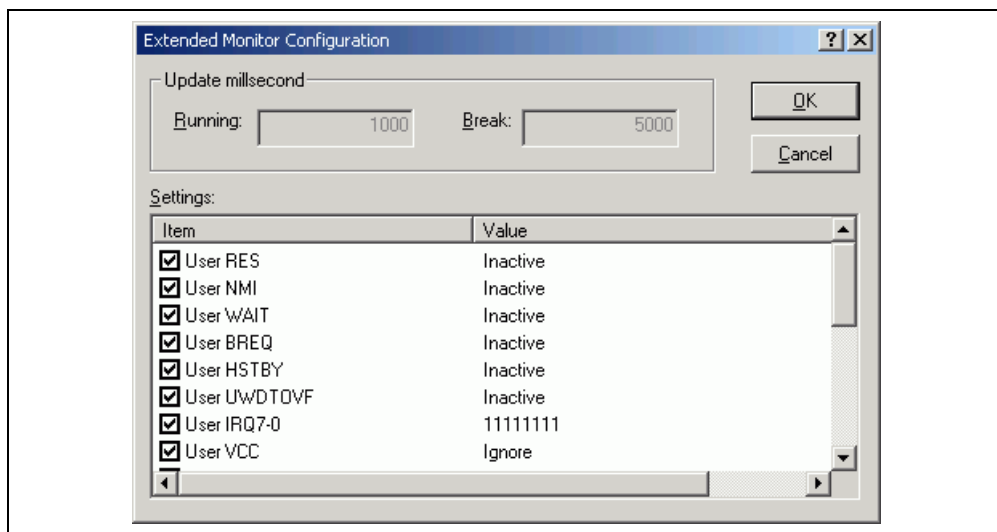

Figure 3.11 [Extended Monitor Configuration] Dialog Box

This dialog box allows the user to set the items to be displayed in the [Extended Monitor] window.

Note: The items that can be set in this window depend on the emulator in use. For details, refer to the online help.

3.5 Displaying Memory Contents in Realtime

Use the [Monitor] window to monitor the memory contents during user program execution. In the Monitor function, the realtime operation is retained since the bus monitoring circuit of the emulator sets the read/write signal of the MCU as a trigger and holds the address bus and data bus values to update the displayed contents of the memory.

Up to eight points or 256 bytes in total can be set by using the eight monitoring channels on the bus monitoring circuit. It is possible that a part or all of monitoring ranges is overlapped.

- Notes:
1. Monitoring is impossible for an area, such as an on-chip timer counter, where no internal write signal is generated to update a value.
 2. The procedure to display or modify the contents of memory differs depending on the product. If the display of memory contents is updated during execution of the user program, realtime emulation may not be available. For details, refer to section 5.3, Displaying and Modifying the Contents of Memory.

3.5.1 Opening the [Monitor] Window

To open the [Monitor] window, select [View -> CPU -> Monitor -> Monitor Setting...] or click the [Monitor] toolbar button () to display the [Monitor Settings] dialog box.

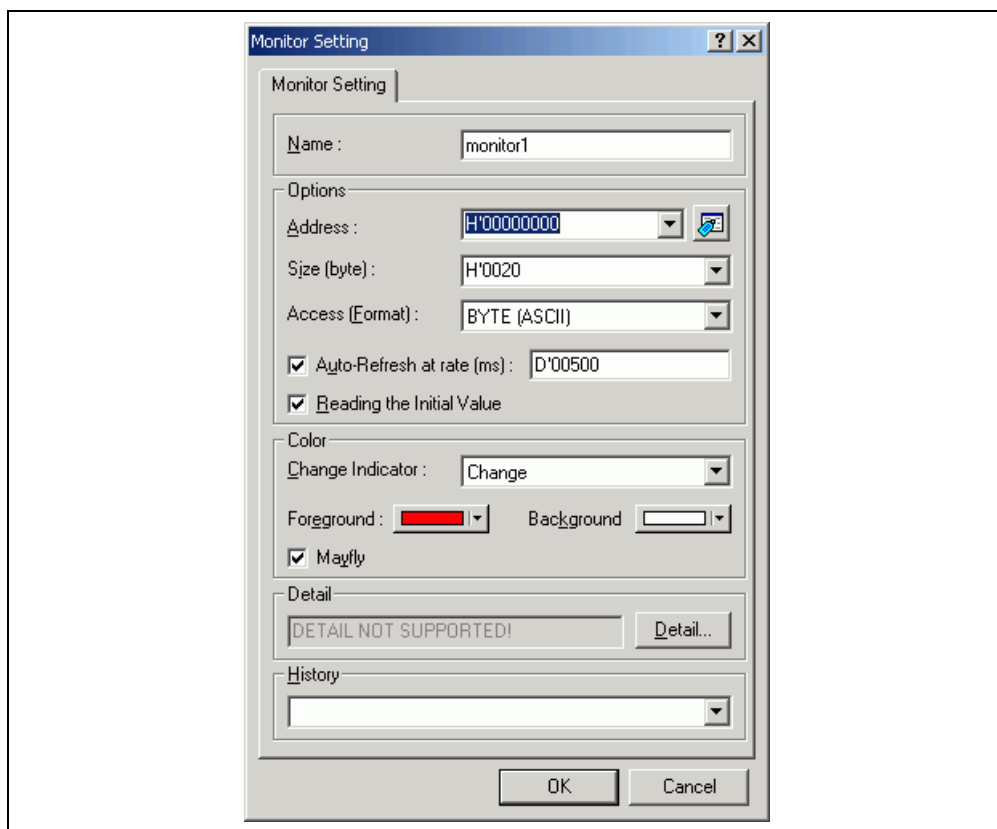

Figure 3.12 [Monitor Setting] Dialog Box

- [Name]: Decides the name of the monitor window.
- [Options]: Sets monitor conditions.
- [Address]: Sets the start address for monitoring.
- [Size]: Sets the range for monitoring.
- [Access]: Sets the access size to be displayed in the monitor window.
- [Auto-Refresh at rate]: Sets the interval for acquisition by monitoring (500 ms at minimum).
- [Reading the Initial Value]: Selects reading of the values in the monitored area when the monitor window is opened.
- [Color]: Sets the method to update monitoring and the attribute of colors.
- [Change Indicator]: Selects how to display the values that have changed during monitoring (available when [Reading the Initial Value] has been selected).
- No change:** No color change.
- Change:** Color is changed according to the [Foreground] and [Background] options.
- Gray:** Those data with values that have not been changed are displayed in gray.
- Appear:** A value is only displayed after changed.
- [Foreground]: Sets the color used for display (available when [Change] has been selected).
- [Background]: Sets the background color (available when [Change] has been selected).
- [Mayfly]: A check in this box selects restoration of the color of those data which have not been updated in a specified interval to the color selected in the [Background] option. The specified interval is the interval for monitor acquisition (available when [Change], [Gray], or [Appear] has been selected).
- [Detail]: Sets the items specific to the emulator.
- [History]: Displays the previous settings.
- Notes: 1. In this emulator, odd addressees cannot be specified as the start addresses for monitoring.
2. Selection of the foreground or background color may not be available depending on the operating system in use.

After setting, clicking the [OK] button displays the [Monitor] window.

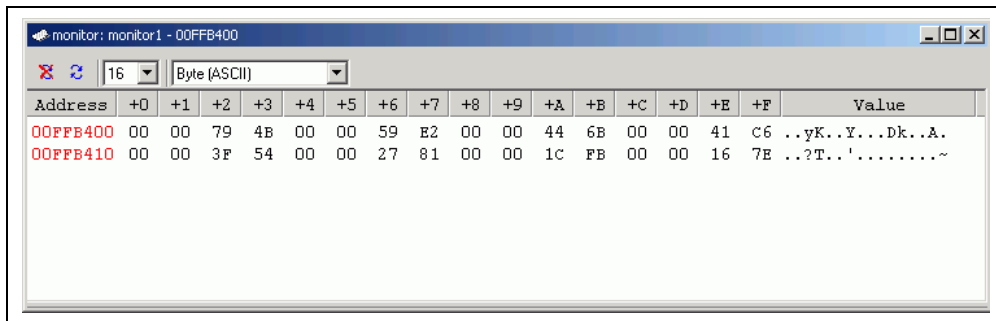

Figure 3.13 [Monitor] Window

During user program execution, the display is updated according to the setting value of the auto-update interval.

Note: Select [Refresh] from the popup menu when data is not displayed correctly after changing the address or content of memory.

3.5.2 Changing the Monitor Settings

Selecting [Monitor Setting...] from the popup menu of the [Monitor] window displays the [Monitor Setting] dialog box, which allows the settings to be changed.

Colors, the size of accesses, and the display format can be easily changed from [Color] or [Access] of the popup menu.

3.5.3 Temporarily Stopping Update of the Monitor

During user program execution, the display of the [Monitor] window is automatically updated according to the auto-update interval. Select [Lock Refresh] from the popup menu of the [Monitor] window to stop the update of display. The characters in the address section are displayed in black, and the update of display is stopped.

Selecting [Lock Refresh] again from the popup menu cancels the stopped state.

3.5.4 Deleting the Monitor Settings

Selecting [Close] from the popup menu of the [Monitor] window to be deleted closes the [Monitor] window and deletes the monitor settings.

3.5.5 Monitoring Variables

Using the [Watch] window refers to the value of any variables.

When the address of the variable registered in the [Watch] window exists within the monitoring range that has been set by the Monitor function, the value of the variable can be updated and displayed.

This function allows checking the content of a variable without affecting the realtime operation.

3.5.6 Hiding the [Monitor] Window

When using the Monitor function to monitor the value of a variable from the [Watch] window, hide the [Monitor] window for the effective use of the screen.

The current monitoring information is listed as the submenu when selecting [Display -> CPU -> Monitor]. The list consists of the [Monitor] window name and the address to start monitoring.

When the left of the list is checked, the [Monitor] window is being displayed.

Selecting items of the [Monitor] window you want to hide from the monitor setting list displays no [Monitor] window and removes the check mark at the left of the list.

To display the [Monitor] window again, select the hidden the [Monitor] window.

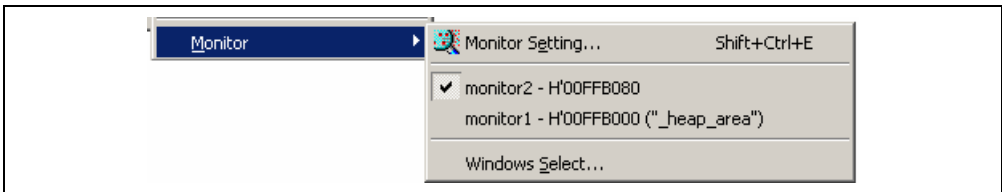

Figure 3.14 Monitor Setting List

3.5.7 Managing the [Monitor] Window

Selecting [Display -> CPU -> Monitor -> Windows Select...] displays the [Windows Select] dialog box. In this window, the current monitoring condition is checked and the new monitoring condition is added, edited, and deleted in succession.

Selecting multiple monitoring conditions enables a temporary stop of update, hiding, and deletion.

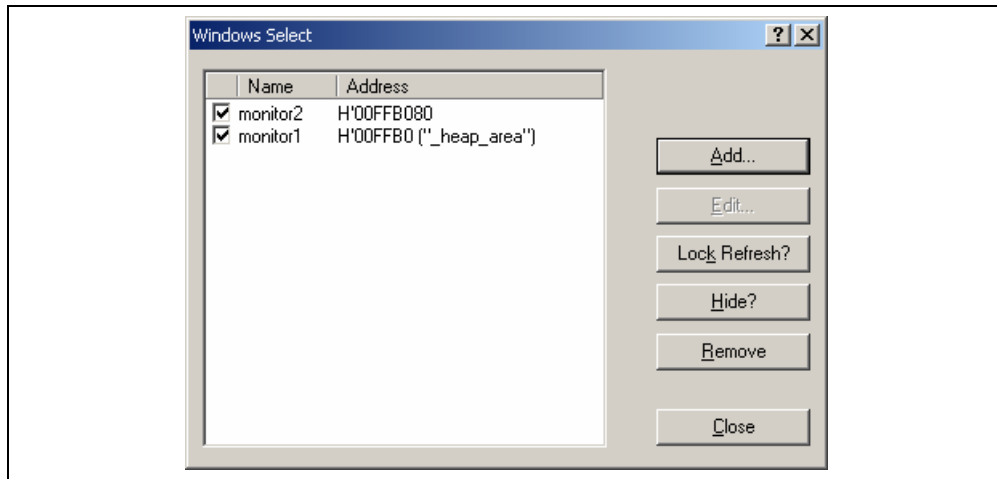

Figure 3.15 [Windows Select] Dialog Box

[Add]: Adds a new monitoring condition.

[Edit]: Changes the settings of the selected [Monitor] window (disabled when selecting multiple items).

[Lock Refresh/Unlock Refresh]: Automatically updates or stops updating the display of the selected [Monitor] window.

[Hide/UnHide]: Displays or hides the selected [Monitor] window.

[Remove]: Removes the selected monitoring conditions.

[Close]: Closes this dialog box.

3.6 Looking at Variables

This section describes how you can look at variables in the source program.

3.6.1 [Watch] Window

You can view any value in the [Watch] window.

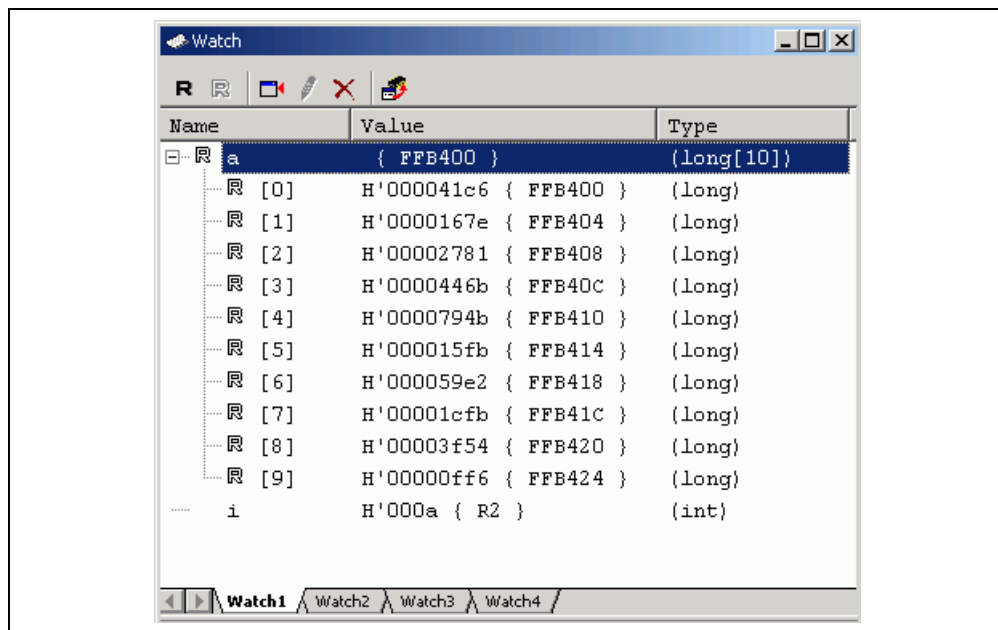

Figure 3.16 [Watch] Window

The [R] mark shows that the value of the variable can be updated during user program execution.

It is possible to recognize the method for updating the value during user program execution according to the color of the [R] mark.

Blue-outline [R]: The address of the variable is within the range that has been set for the monitoring function and the data is readable by using the monitoring function.

Blue [R]: An updated value of the data at this location has been read by the monitoring function.

Black-outline [R]: The address of the variable is outside the range that has been set for the monitoring function and the data is not readable by using the monitoring function.

Black [R]: A value has been updated by reading the normal data.

- Notes:
1. This function can be set per variable or per element or body for structures of data.
 2. The color of an [R] in the [Name] column changes according to the monitoring settings.
 3. A variable that is allocated to a register cannot be selected for monitoring.
 4. The procedure to display or modify the contents of memory differs depending on the product. If the display of memory contents is updated during execution of the user program, realtime emulation may not be available. For details, refer to section 5.3, Displaying and Modifying the Contents of Memory.
 5. The SH7059 E6000H emulators incorporate a dedicated on-chip RAM monitor of 256 bytes \times 12 points for the watch function that only allows the contents of the on-chip RAM to be displayed in realtime. Enabling Auto Update after registering variables automatically allows use of this on-chip RAM monitor, while disabling Auto Update or deleting variables cancels use of the on-chip RAM monitor. When Auto Update is enabled while all of the 12 points of this on-chip RAM monitor are in use, the values will be updated by reading data as usual. To display the contents of memory other than the on-chip RAM in realtime, use the normal monitor.

3.7 Using the Event Points

The emulator has the event point function to support breakpoints of the following three types.

Software breakpoints: Execution of the user program stops when the instruction at the specified address is fetched. Up to 255 software breakpoints can be set. Any content at the specified address is replaced by a break instruction (a dedicated instruction for use with the emulator). The software breakpoint cannot be set in the write-protected area such as ROM area or flash memory area on the user system. The user can set a software breakpoint in the [Editor] or [Disassembly] window.

On-chip breakpoints: These break functions built in the MCU. Conditions on the address bus, data bus, bus/area, and satisfaction count can be set. The on-chip breakpoint can be set even in the ROM area or flash memory area on the user system. It is also possible to set a sequential breakpoint consisted of several on-chip breakpoints. The user can set an on-chip breakpoint in the [Editor] or [Disassembly] window.

On-emulator breakpoints: On-emulator break functions are implemented by dedicated hardware in the E6000H station. Conditions on the address bus, data bus, bus/area, external probe signals, external interrupt signals, and satisfaction count can be set. As the emulator hardware provides this function, several cycles may be required until a break occurs after satisfaction of a condition.

Software, on-chip, and on-emulator breakpoints can be set in the [Event] window.

Select [View -> Code -> Eventpoints] or click the [Eventpoints] toolbar button  to open the [Event] window.

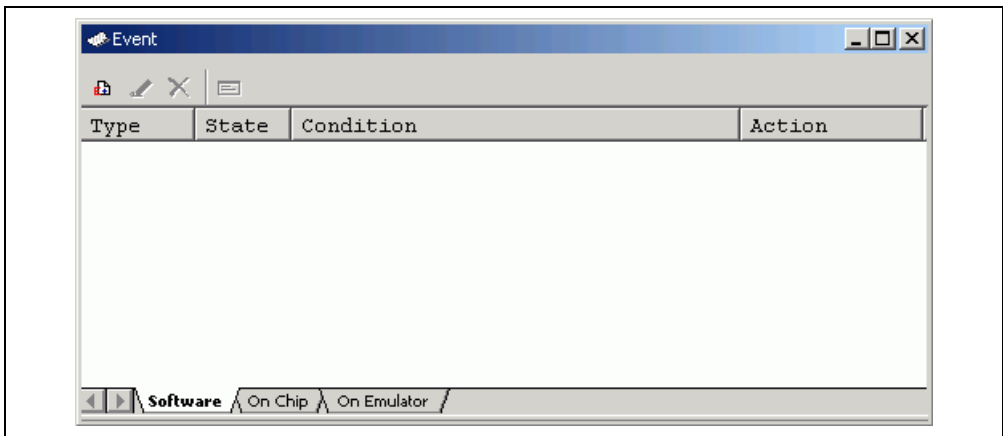

Figure 3.17 [Event] Window

The [Event] window has the following three sheets:

[Software] sheet: Displays the settings made for software breakpoints. It is also possible to set, modify, and cancel software breakpoints.

[On Chip] sheet: Displays or sets on-chip breakpoints.

[On Emulator] sheet: Displays or sets on-emulator breakpoints.

Note: For notes on event points, refer to section 5.5, Event Functions.

3.7.1 Setting a Software Breakpoint

Use the [Software] sheet on the [Event] window to display, change, or add settings for software breakpoints.

Select [Add...] or [Edit...] from the popup menu displayed on the [Software] sheet. The [Breakpoint Properties] dialog box (the [Software Break] page) will appear.

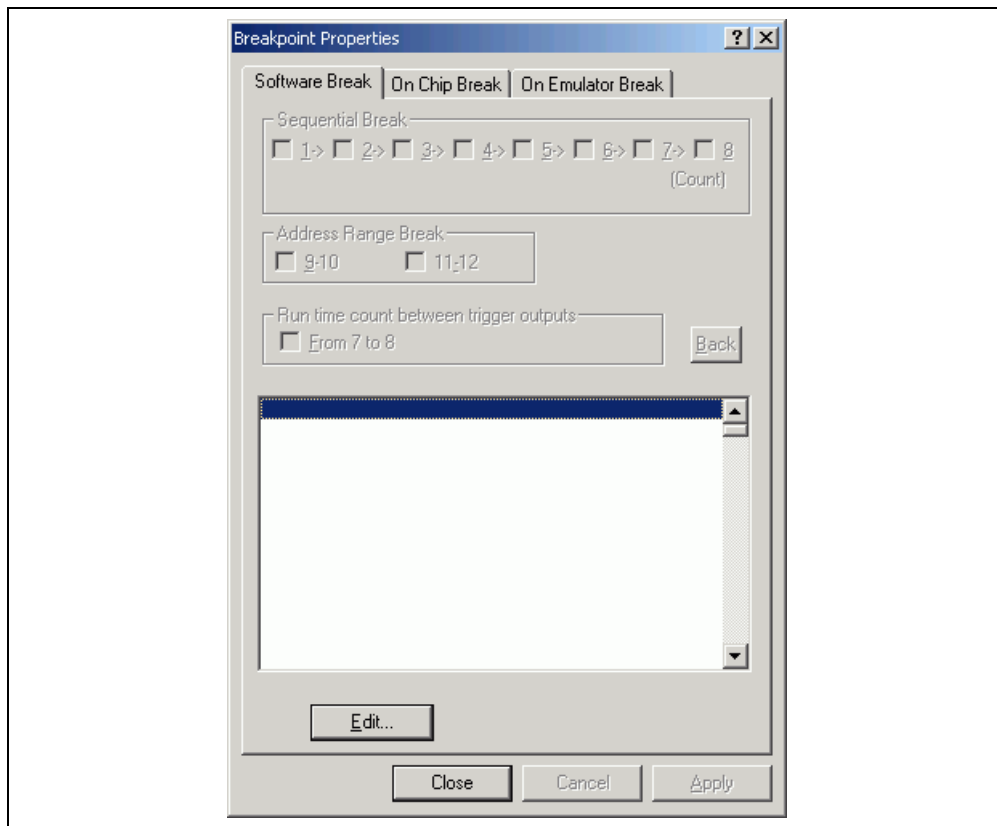

Figure 3.18 [Breakpoint Properties] Dialog Box ([Software Break] Page)

To add a new software breakpoint, select an empty line from the list box on the [Software Break] page and click the [Edit...] button. To change existing settings, select the software breakpoint that you want to change from the list box and click the [Edit...] button. The [Software Break] dialog box is displayed.

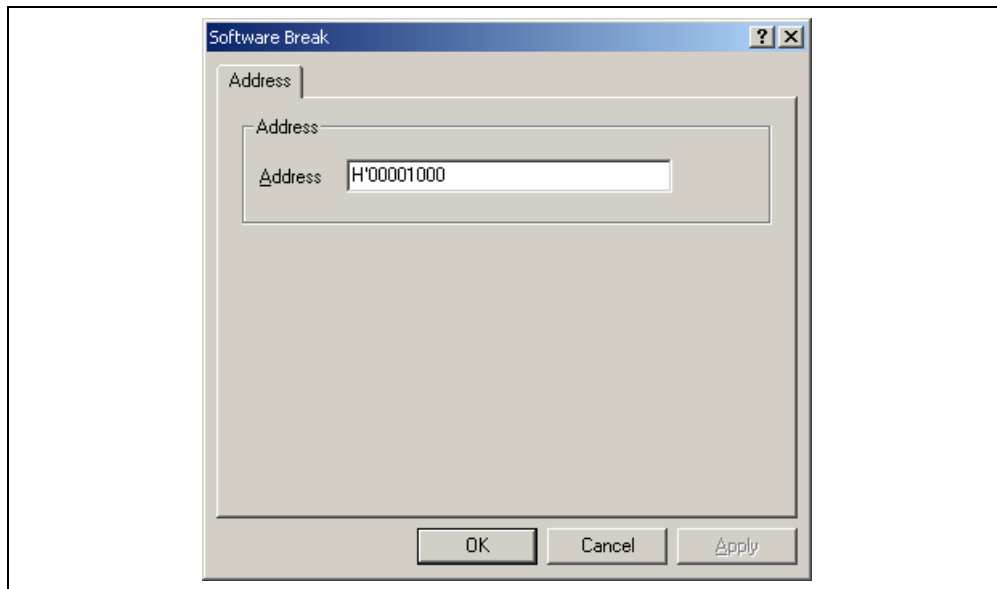

Figure 3.19 [Software] Dialog Box ([Address] Page)

Specify the breakpoint's address in the [Address] edit box and click the [OK] button.

3.7.2 Setting an On-Chip Breakpoint

Use the [On Chip] sheet on the [Event] window to display, change, or add settings for on-chip breakpoints.

Select [Add...] or [Edit...] from the popup menu displayed on the [On Chip] sheet. The [Breakpoint Properties] dialog box (the [On Chip Break] page) will appear.

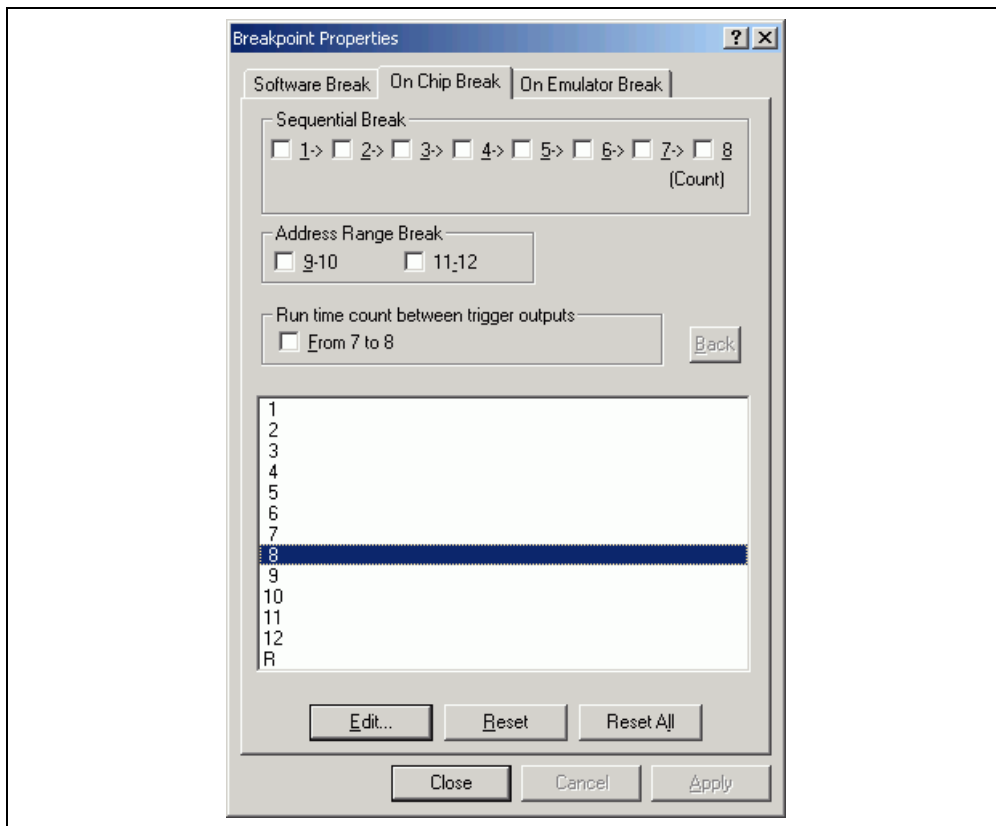

Figure 3.20 [Breakpoint Properties] Dialog Box ([On Chip Break] Page)

[Sequential Break]: Specifies a sequential break that uses channels 1 to 8. Channels are specified in a sequential order. When channels other than 1 to 8 or 5 to 8 are used, the channels shown as UNUSED are not available.

[Address Range Break]: Specifies the combination of channels and the range of halting a break. For channels, select either of the followings.

9-10: Channels 9 and 10 are used to specify the range of break.

11-12: Channels 11 and 12 are used to specify the range of break.

[Run time count between trigger outputs]:

Measures the time between two points by using channels 7 and 8. After channel 7 has been satisfied, the time is measured when channel 8 is satisfied. The result is displayed in [RunTime Count] on the [Platform] sheet of the [Status] window.

- [Back]: Puts the setting back to the previous state at the time the dialog box has been displayed.
- List box: Displays the current settings for each of the channels. R shown as a channel number indicates the reset point of a sequential break. If no setting has been made for a channel, only the channel number is displayed here. When a channel is used for the sequential break function, S is displayed next to the channel number.
- [Edit...]: Clicking this button opens the [On Chip Break Channel n] dialog box (n: channel number), which allows the user to set a break condition for a selected channel.
- [Reset]: Clears the settings made for the selected channel.
- [Reset All]: Clears the settings made for all of the channels.

The user can set more complex break conditions in the [On Chip Break Channel n] dialog box by a combination of conditions provided on pages [Address], [Data], [Bus/Area], [Count], and [Action].

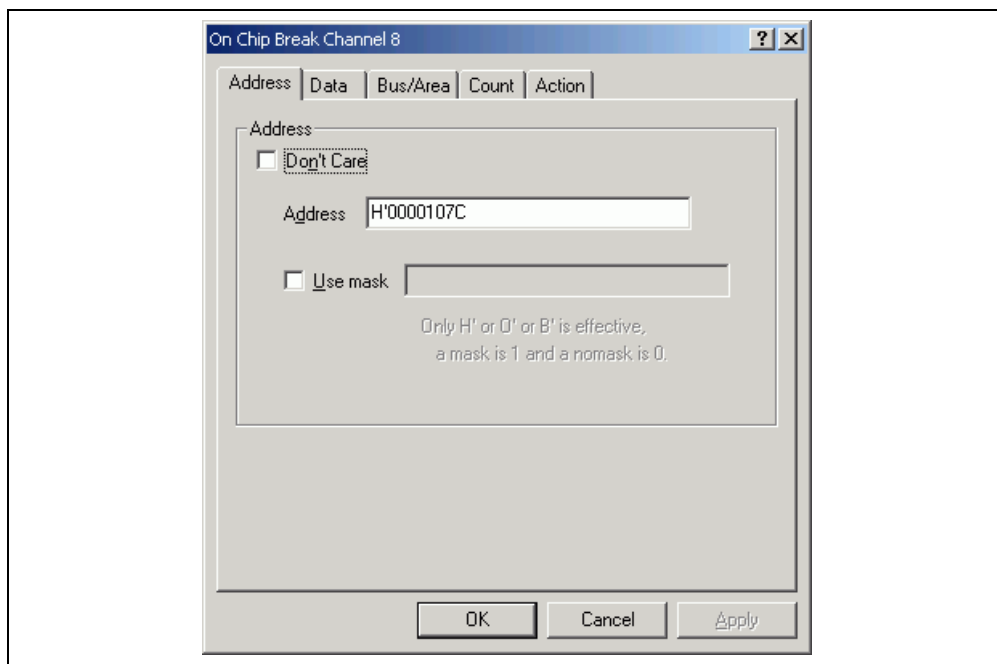

Figure 3.21 [On Chip Break Channel n] Dialog Box

[Address]: Sets address bus conditions.

[Don't Care]: Selects no address bus condition.

[Address]: Sets an address bus value.

[Use mask]: Sets mask conditions. Set the mask bits if [Use mask] is selected. Masked bits satisfy this break condition regardless of their values.

[Data]: Sets data bus conditions.

[Don't Care]: Selects no data bus condition.

[Value]: Sets a data bus value.

[Use mask]: Sets mask conditions. Set the mask bits if [Use mask] is selected. Masked bits satisfy this break condition regardless of their values.

[Access Size]: Selects the data-access size.

[Bus/Area]: Sets access type, bus status, and read/write cycle conditions.

[Access type]: Sets access type conditions.

[Bus State]: Sets bus status conditions. When [Don't Care] has been selected, no bus status condition can be set.

[Read/Write]: Sets read/write conditions. When [Don't Care] has been selected, no read/write condition can be set.

[Count]: Sets the satisfaction count of the condition. When [Don't Care] has been selected, the satisfaction count is defined as 1.

[Action]

[Break]: Halts execution when the selected condition has been satisfied.

[After execution]: Halts execution after the address at which the condition has been satisfied.

[Before execution]: Halts execution before the address at which the condition is satisfied.

[Output Trigger]: Outputs a trigger when the selected condition has been satisfied.

3.7.3 Settings an On-Emulator Breakpoint

Use the [On Emulator] sheet on the [Event] window to display, change, or add settings for on-emulator breakpoints.

Select [Add...] or [Edit...] from the popup menu displayed on the [On Chip] sheet. The [Breakpoint Properties] dialog box (the [On Emulator Break] page) will appear.

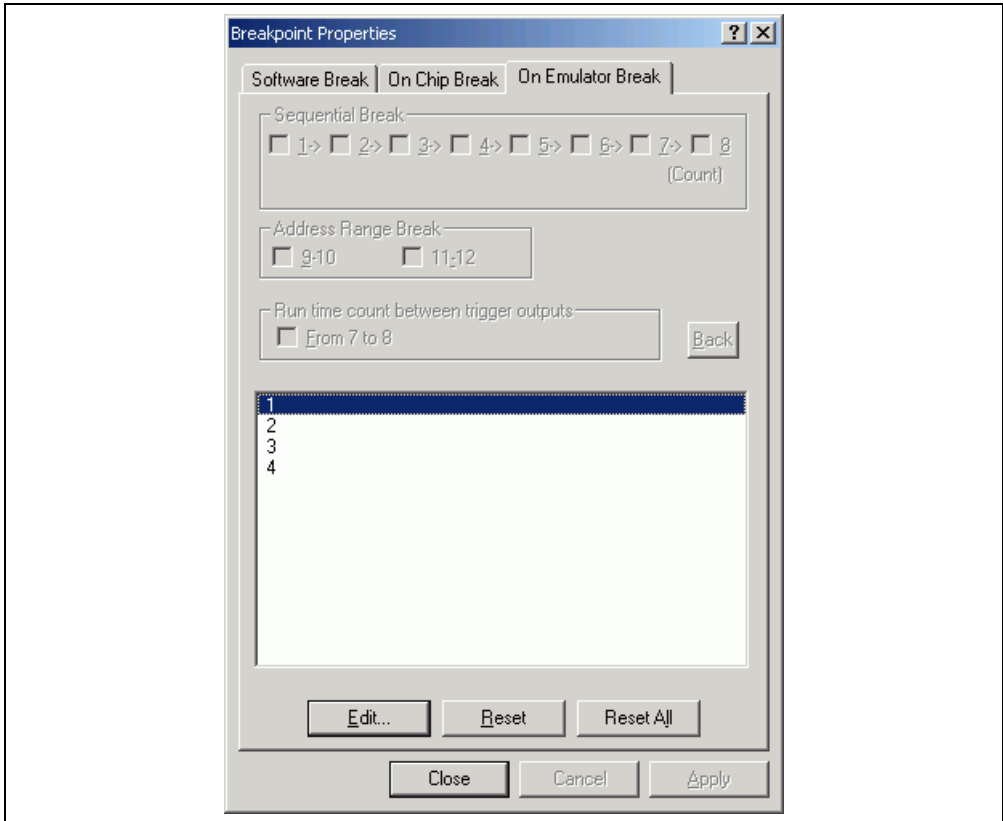

Figure 3.22 [Breakpoint Properties] Dialog Box ([On Emulator Break] Page)

- List box: Displays the current settings for each of the channels. If no setting has been made for a channel, only the channel number is displayed here.
- [Edit...]: Clicking this button opens the [On Emulator Break Channel n] dialog box (n: channel number), which allows the user to set a break condition for a selected channel.
- [Reset]: Clears the settings made for the selected channel.
- [Reset All]: Clears the settings made for all of the channels.

The user can set more complex break conditions in the [On Emulator Break Channel n] dialog box by a combination of conditions provided on pages [Address], [Data], [Bus/Area], [Probe], [Interrupt], and [Count].

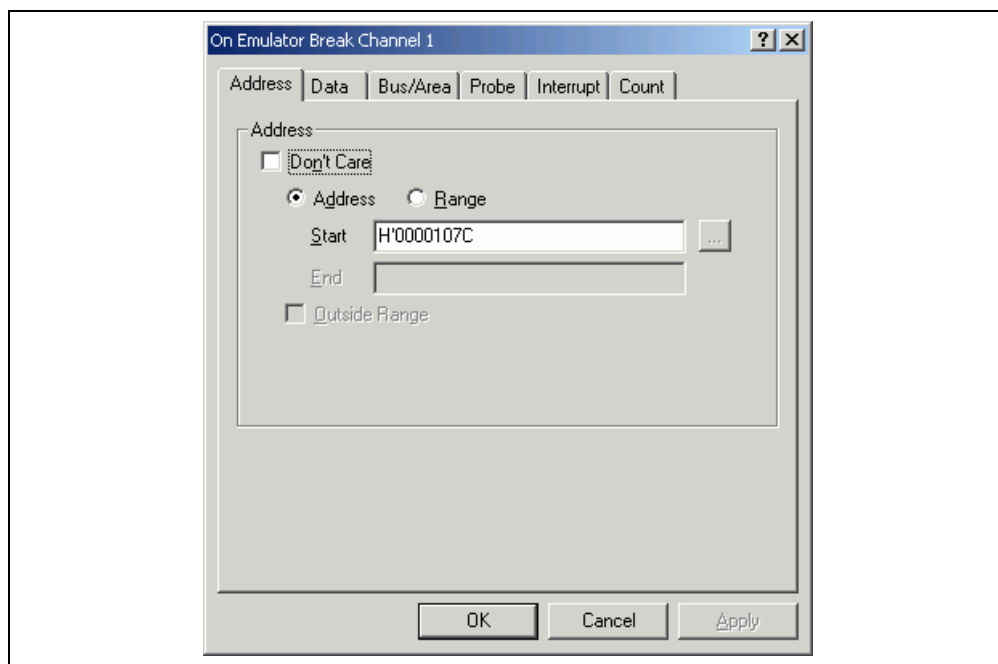

Figure 3.23 [On Emulator Break Channel n] Dialog Box

[Address]:	Sets address conditions.
[Don't Care]:	Selects no address bus condition.
[Address]:	Select this button to set the address bus value specified in [Start] as the break condition.
[Range]:	A break occurs in the range of the address bus values specified from [Start] (start address) to [End] (end address).
[Outside Range]:	Select this option to generate a break with an address bus outside the range set in [Range].
[f()...]:	The address range of a function can be set by [Start] and [End]. For details, refer to section 5.10, Input Format.
[Data]:	Sets data conditions.
[Don't Care]:	Selects no data bus condition.
[Value]:	Sets a data bus value.
[Use mask]:	Sets mask conditions. Set the mask bits if [Use mask] is selected. Masked bits satisfy this break condition regardless of their values.
[Except this value]:	Sets a value other than that has been specified as the data bus condition.
[Access Size]:	Selects the data-access size.
[Position]:	Sets a data bus value as a number. The position of the valid data bus is specified.
[Long]:	None
[Word]:	4n: Upper word 4n + 2: Lower word
[Byte]:	4n: Upper byte of the upper word 4n + 1: Lower byte of the upper word 4n + 2: Upper byte of the lower word 4n + 3: Lower byte of the lower word
[Bus/Area]:	Sets access type, bus status, and read/write cycle conditions.
[Access type]:	Sets access type conditions. When [Don't Care] has been selected, no access type condition can be set.
[Bus State]:	Sets bus status conditions. When [Don't Care] has been selected, no bus status condition can be set.
[Read/Write]:	Sets read/write conditions. When [Don't Care] has been selected, no read/write condition can be set.
[Probe]:	Sets the levels (high or low) of the external probe signals (PRB1 to PRB4) as the condition. When [Don't Care] has been selected, the level of the selected probe signal cannot be set as the condition.

- [Interrupt]: Sets the levels (high or low) of the IRQ and NMI signals as the condition. When [Don't Care] has been selected, the level of the IRQ or NMI signal cannot be set as the condition.
- [Count]: Sets a satisfaction count condition. When [Don't Care] has been selected, the satisfaction count is defined as 1.

3.7.4 Editing Event Points

Handlings for settings other than software breakpoints, on-chip breakpoints, and on-emulator breakpoints are common.

3.7.5 Modifying Event Points

Select an event point to be modified, and choose [Edit...] from the popup menu to open the dialog box that corresponds the event, which allows the user to modify the event conditions. The [Edit...] menu is only available when one event point is selected.

3.7.6 Enabling an Event Point

Select an event point and choose [Enable] from the popup menu to enable the selected event point.

3.7.7 Disabling an Event Point

Select an event point and choose [Disable] from the popup menu to disable the selected event point. When an event point is disabled, the event point will remain in the list, but an event will not occur when the specified conditions have been satisfied.

3.7.8 Deleting an Event Point

Select an event point and choose [Delete] from the popup menu to remove the selected event point. To retain the event point but not have it cause an event when its conditions are met, use the [Disable] option (see section 3.15.7, Disabling an Event Point).

3.7.9 Deleting All Event Points

Choose [Delete All] from the popup menu to remove all event points.

3.7.10 Viewing the Source Line for an Event Point

Select an event point and choose [Go to Source] from the popup menu to open the [Editor] or [Disassembly] window at the address of the event point. The [Go to Source] menu is only available when one event point that has the corresponding source file is selected.

3.8 Viewing the Trace Information

The emulator acquires the results of each instruction execution into the trace buffer as trace information and displays it in the [Trace] window. The conditions for the trace information acquisition can be specified in the [Trace Acquisition] dialog box.

Since trace information in bus-cycles is acquired by the hardware circuit and stored in the trace buffer, the realtime operation is retained. The [Trace] window displays the content of the trace buffer, which records up to 128-k bus cycles from the last program run and is always updated.

Note: For notes on the trace functions, refer to section 5.6, Trace Functions.

3.8.1 Opening the [Trace] Window

To open the [Trace] window, choose [View -> Code -> Trace] or click the [Trace] toolbar button .

3.8.2 Acquiring Trace Information

When the emulator does not set the acquisition condition of the trace information, all bus cycles are acquired by default without any condition (free trace mode).

In the free trace mode, trace acquisition is started with the execution of the user program and stopped by halting the user program. The acquired trace information is displayed in the [Trace] window.

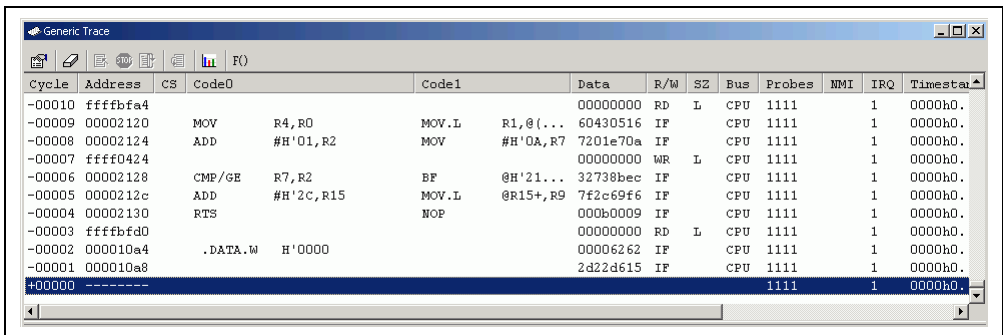

Cycle	Address	CS	Code0	Code1	Data	R/W	SZ	Bus	Probes	NMI	IRQ	Time
-00010	ffffbfa4				00000000	RD	L	CPU	1111		1	0000h0.
-00009	00002120		MOV R4, R0	MOV.L	R1, @(...	60430516	IF	CPU	1111		1	0000h0.
-00008	00002124		ADD #H'01, R2	MOV	#H'0A, R7	7201e70a	IF	CPU	1111		1	0000h0.
-00007	ffff0424				00000000	WR	L	CPU	1111		1	0000h0.
-00006	00002128		CMP/GE R7, R2	BF	@H'21... 32738bec	IF	CPU	1111			1	0000h0.
-00005	0000212c		ADD #H'2C, R15	MOV.L	@R15+, R9	7f2e69f6	IF	CPU	1111		1	0000h0.
-00004	00002130		RTS	HOP	000b0009	IF	CPU	1111			1	0000h0.
-00003	ffffbfd0				00000000	RD	L	CPU	1111		1	0000h0.
-00002	000010a4		.DATA.W H'0000		00006262	IF	CPU	1111			1	0000h0.
-00001	000010a8				2d22d615	IF	CPU	1111			1	0000h0.
+00000	-----								1111		1	0000h0.

Figure 3.24 [Trace] Window

This window displays the following trace information items:

[PTR]:	Cycle number in the trace buffer. When the most recent record is record 0, earlier record numbers go backwards (-1, -2, ...). If a delay count has been set, the cycle number where the trace stop condition has been satisfied is record 0. For the cycle (during delay) executed until the trace has stopped, earlier record numbers go forward (+1, +2, ...) the most recent record.
[Address]:	Address on the processor bus
[CS]:	CS area (the SH7059 E6000H emulator does not have this item)
[Code0]:	Upper 16-bit instruction code being executed
[Code1]:	Lower 16-bit instruction code being executed

[Data]:	Data in byte, word, or longword units, displayed as 2-digit, 4-digit, or 8-digit hexadecimal
[R/W]:	Whether the cycle was for reading, writing, or fetching. IF: Fetch cycle RD: Read cycle WR: Write cycle
[SZ]:	Selects the size of an access as B (byte), W (word), or L (longword).
[Bus]:	Bus mastership
[Probes]:	A 4-bit binary number showing the four probe pins in the order of Probe 4, Probe 3, Probe 2, and Probe 1 from the left.
[NMI]:	NMI signal state
[IRQ]:	IRQ signal states (0: low level, 1: high level) showing in the order of IRQ7 to IRQ0 from the left. If the 32-bit time stamp counter is enabled, the states of IRQ7 to IRQ0 are ANDed and this result will be displayed.
[Timestamp]:	Time stamp of the record. Time stamps start from zero each time the user program is executed. Select the minimum unit used in time measurement in the [Trace Acquisition Properties] dialog box.
[Source]:	Source program of the executed instruction address
[Label]:	Label information of the address (if defined)
[Timestamp-Difference]	Difference from the timestamp value shown on the previous line

It is possible to hide any column not necessary in the [Trace] window. Selecting a column you want to hide from the popup menu displayed by clicking the right-hand mouse button on the header column hides that column. To display the hidden column, select the column from the said popup menu again.

3.8.3 Specifying Trace Acquisition Conditions

The capacity of the trace buffer is limited. When the buffer becomes full, the oldest trace information is overwritten. Setting the trace acquisition condition allows acquisition of useful trace information and effective use of the trace buffer.

There are the following types of trace acquisition conditions.

Free trace: Acquires trace information continuously from the start of the user program execution to the occurrence of a break (only when no trace acquisition condition is set).

Sequential trace stop: Specifies the order of trace acquisition conditions to be satisfied and stops trace acquisition when all of the conditions are satisfied. It is possible to set up to seven pass points and one reset point. No break will occur even when the trace acquisition stops.

Trace stop due to trace buffer overflow: Stops trace acquisition when the trace buffer in the emulator station overflows. No break will occur even when the trace acquisition stops.

Trace stop: Stops trace acquisition when the specified conditions are satisfied. In this mode, trace acquisition stops without stopping the user program execution. Up to 12 points can be set independently as trace stop conditions. No break will occur even when the trace acquisition stops.

Address range trace: Acquires trace information of instructions or operands accessed in the range (subroutine) between the start and end addresses. Note that, however, when the selected subroutine calls another subroutine, no trace information will be acquired from the called subroutine. Up to 12 points can be set independently as the address ranges.

Conditional trace: Only acquires trace information from the points where the specified conditions are satisfied. Up to 12 points can be set independently as the conditions.

Address range conditional trace: Accesses instructions or operands in the range (subroutine) between the start and end addresses and only acquires trace information in the bus cycles that satisfy the conditions. This mode is a combination of address range trace and conditional trace. Up to six points can be set independently as the address ranges with conditions.

Point to Point trace: Acquires trace information from the satisfaction of the address condition set as a start condition to that of the address condition set as an end condition.

Execution time measurement: Measures execution time between two points by using the trace acquisition conditions.

Trigger output: Outputs a pulse from trigger pins when the specified conditions are satisfied.

The trace acquisition condition is set in the [Trace Acquisition] dialog box that is displayed by selecting [Acquisition...] from the popup menu.

The [Trace Acquisition Properties] dialog box has the pages [Condition] and [Other].

(1) [Condition] page

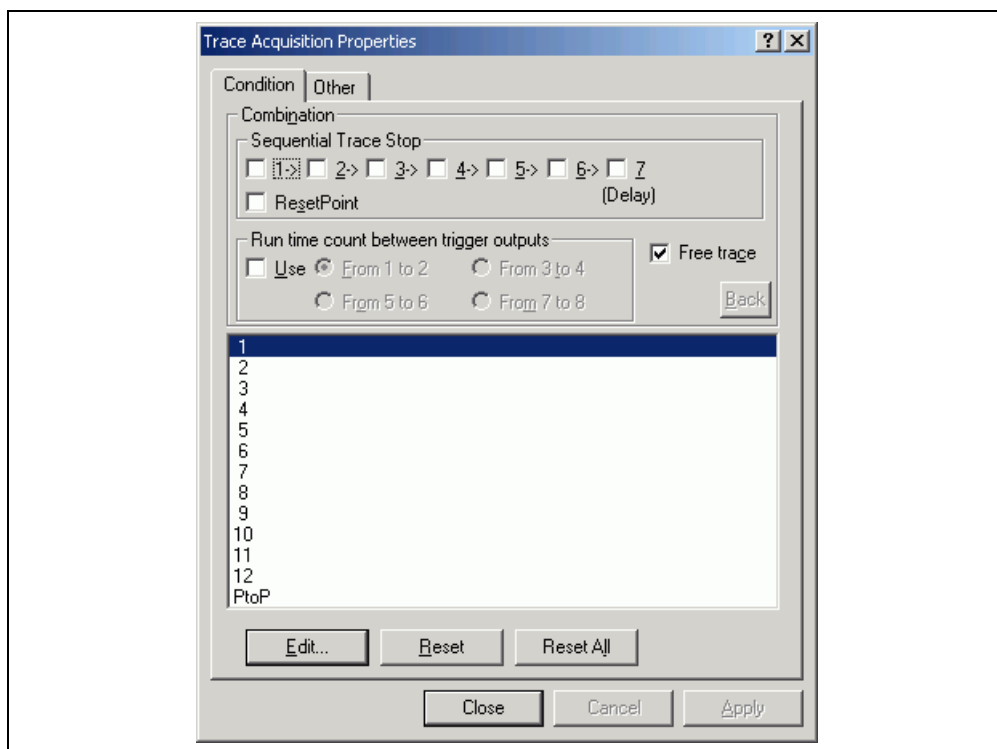

Figure 3.25 [Trace Acquisition Properties] Dialog Box ([Condition] Page)

[Sequential Trace Stop]: Use this option to set a sequential trace stop by using channels 1 to 7. The sequential trace stop function allows trace acquisition to stop when the conditions of several channels are satisfied in the specified order. Two to seven pass points and one reset point are selectable as sequential trace stop conditions. The conditions are satisfied in the order of 1 to 7. To use a sequential trace stop, select the checkbox of the channel. To set a reset condition, select the [Reset Point] checkbox. Channel 8 is used for a reset condition. When a reset condition is satisfied, all the sequential trace stop conditions that have been satisfied will be cleared and the emulator starts checking the first condition again. When a sequential trace stop is enabled, no setting is available for the channels (out of 1 to 7) that are not used for the sequential trace stop function.

[Run time count between trigger outputs]: Selects channels for use in execution time measurement. Clicking [Use] allows measurement of time in tracing. There are four types of channel combinations consisted of those for the start and the end of measurement: 1-2, 3-4, 5-6, and 7-8.

[Free trace]: Selects the free trace mode. When [Free trace] is enabled, any trace acquisition condition set will be ignored.

[Back]: Puts the setting back to the previous state at the time the dialog box has been displayed.

- List box: Displays the current settings for each of the channels. If no setting has been made for a channel, only the channel number is displayed here. When a channel is used for the sequential trace stop function, S is displayed next to the channel number. When a reset condition for a sequential trace stop is enabled, R is displayed next to channel 8. PtoP is for use in the Point to Point trace. UNUSED is displayed next to the channel number if that channel is not available.
- [Edit...]: Clicking this button opens the [Trace Acquisition Condition Channel n] dialog box (n: channel number or PtoP), which allows the user to set a break condition for a selected channel.
- [Reset]: Clears the settings made for the selected channel.
- [Reset All]: Clears the settings made for all of the channels.

(2) [Other] page

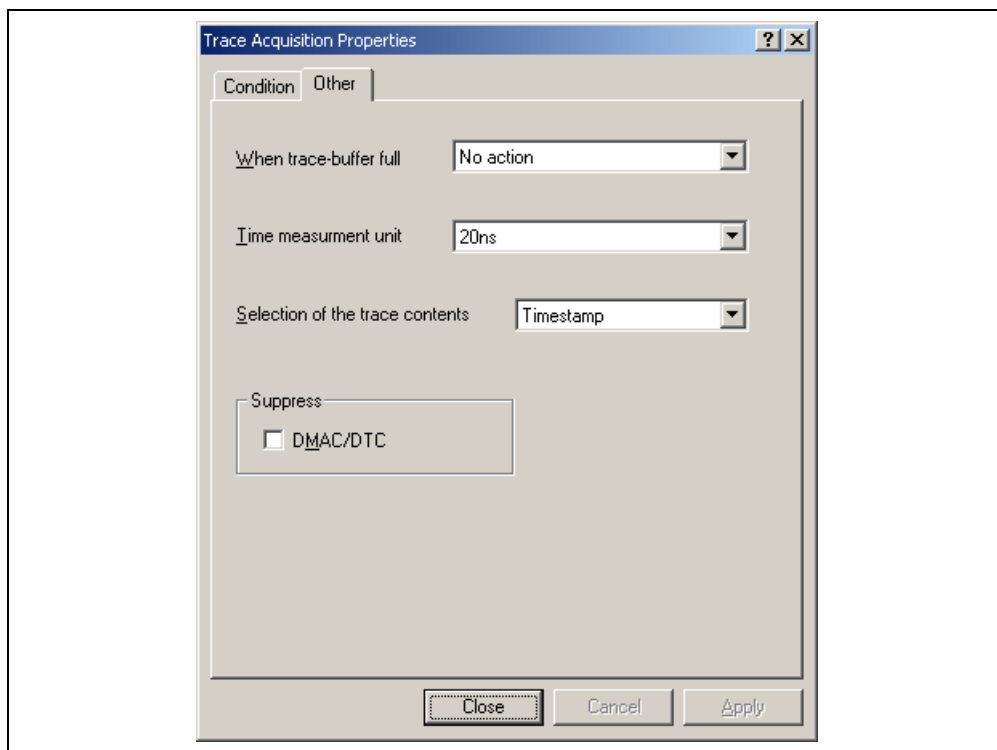

Figure 3.26 [Trace Acquisition] Dialog Box ([Other] Page)

[When trace-buffer full]: Selects an action to take when the trace buffer becomes full.

[No action]: Overwrites the oldest information in the trace buffer.

[Stop trace]: Stops trace acquisition without stopping the user program execution.

[Stop execution and trace]: Stops the user program execution.

[Time measurement unit]: Selects the minimum time unit for the time stamping of the bus trace information.

[52us]: Time stamping is in minimum time units of 52 μ s.

[1.6us]: Time stamping is in minimum time units of 1.6 μ s.

[20ns]: Time stamping is in minimum time units of 20 ns.

[Clock]: Time stamping is in terms of the number of bus-clock cycles, i.e., is synchronized with the cycles of the internal clock signal (ϕ).

[Clock/2]: Time stamping is in terms of the number of bus-clock cycles, i.e., is synchronized with 1/2 cycle of the internal clock signal (ϕ).

[Clock/4]: Time stamping is in terms of the number of bus-clock cycles, i.e., is synchronized with 1/4 cycle of the internal clock signal (ϕ).

[Clock/8]: Time stamping is in terms of the number of bus-clock cycles, i.e., is synchronized with 1/8 cycle of the internal clock signal (ϕ).

[Selection of the trace contents]:

Selects the form to display time stamps and IRQ7 to IRQ0. In this emulator, acquisition of time stamps and IRQ signals in tracing is realized by the same hardware resource. It is thus not available to use the 32-bit time stamp counter and IRQ7 to IRQ0 tracing at the same time. Select either of the following options according to the situation.

[Time stamp]: Enables the 32-bit time stamp counter for display of time stamps. For IRQs, the states of IRQ7 to IRQ0 are ANDed and this result is displayed.

[IRQ7-0 all indications]: Lower 16 bits of time stamps are fixed to 0. The states of IRQ7-0 are displayed respectively.

[Suppress]: Acquires no DMAC or AUD cycles.

(3) [Trace Acquisition Condition Channel n] dialog box

Use this dialog box to set pass points and a reset point for a sequential trace stop, and conditions in the address range trace, address range conditional trace, conditional trace, Point to Point trace, execution time measurement, and a trigger output.

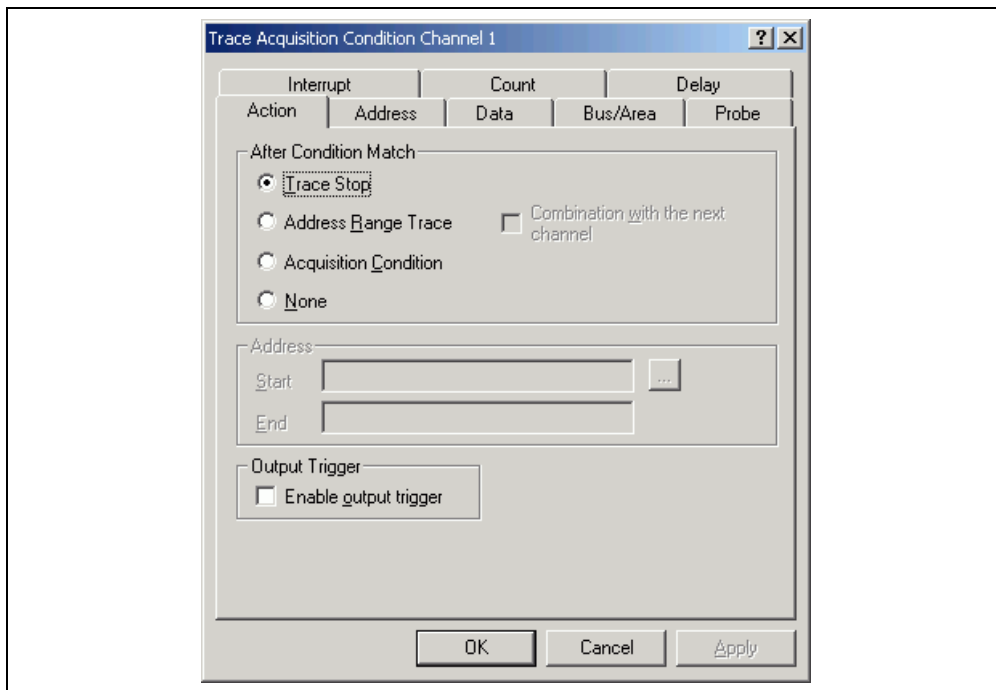

Figure 3.27 [Trace Acquisition Condition Channel n] Dialog Box

The [Trace Acquisition Condition Channel n] dialog box has pages [Action], [Address], [Data], [Bus/Area], [Probe], [Interrupt], [Count], and [Delay]. The user can make more complex settings by a combination of conditions provided on these pages.

[Action]

[After Condition Match]: Selects an action to take when a condition is satisfied.

[Trace Stop]: Selects a trace stop.

[Address Range Trace]: Selects an address range trace. Selecting this option and checking [Combination with the next channel] allows an address range conditional trace.

[Acquisition Condition]: Selects a conditional trace.

[None]: Select this option if you do not want to take any of the actions listed above. This is useful for a trigger output or execution time measurement.

[Address]: Sets the start and end addresses of the range in the address range trace, address range conditional trace, or Point to Point trace.

[Start]:	Set the start address.
[End]:	Set the end address.
[f()...]:	The address range of a function can be set by [Start] and [End].
[Output Trigger]:	Outputs a trigger after the satisfaction of a trace condition.
[Address]:	Sets address conditions.
[Data]:	Sets data conditions.
[Bus/Area]:	Sets access type, bus status, and read/write cycle conditions.
[Probe]:	Sets the levels (high or low) of the external probe signals (PRB1 to PRB4) as the condition.
[Interrupt]:	Sets the levels (high or low) of the IRQ and NMI signals as the condition.
[Count]:	Sets a satisfaction count condition.
[Delay]:	Sets the number of bus cycles delayed after the satisfaction of a trace condition. This function allows you to check the trace information before/after any of the specified conditions are satisfied. When [Don't Care] has been selected, there is no delay.

- Notes:
1. The settings to be made on pages [Address], [Data], [Bus/Area], [Probe], [Interrupt], and [Count] are the same as those for on-emulator break conditions. For details on the on-emulator break conditions, refer to section 3.7, Using the Event Points.
 2. Set the range in the address range trace so that value of the end address will be larger than that of the start address.
 3. Two channels are used in the address range conditional trace. To perform the address range conditional trace, select an odd-numbered channel ($2n + 1$) for the address range trace and an even-numbered channel ($2n + 2$) for the conditional trace, respectively, and then check [Combination with the next channel].

3.8.4 Searching for a Trace Record

Use the [Trace Find] dialog box to search for a trace record. To open this dialog box, choose [Find...] from the popup menu.

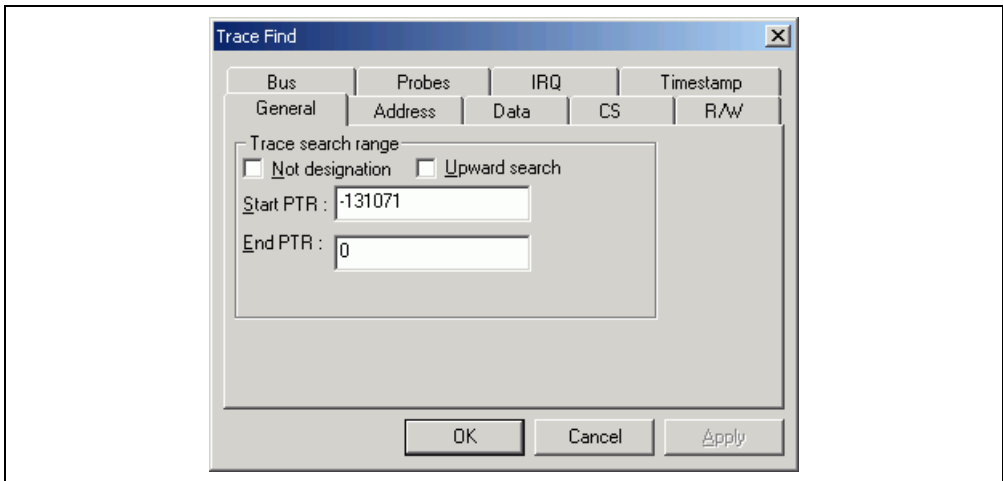

Figure 3.28 [Trace Find] Dialog Box

The [Trace Find] dialog box has the following options:

- [General]: Sets the range for searching.
- [Not designation]: Searches for information that does not match the conditions set in other pages when this box is checked.
 - [Upward search]: Searches upwards when this box is checked.
 - [Start PTR]: Enters a PTR value to start a search.
 - [End PTR]: Enters a PTR value to end a search.
- [Address]: Set an address condition.
- [Don't care]: Detects no address when this box is checked.
 - [Value]: Detects the specified address. Enter an address value.
- [Data]: Set a data condition.
- [Don't care]: Detects no data when this box is checked.
 - [Value]: Detects the specified data. Enter a data value.
- [CS]: Set a CS condition. (No CS condition can be set in the SH7059 E6000H emulator.)
- [Don't care]: Detects no CS when this box is checked.
 - [Value]: Detects the specified CS.
- [R/W]: Select the type of access cycles.

[Don't care]:	Detects no read/write condition when this box is checked.
[Setting]:	Detects the specified read/write condition. [RD]: Read cycle [WR]: Write cycle [IF]: Instruction fetch cycle
[Bus]	Set a bus mastership condition.
[Don't care]:	Detects no bus mastership condition when this box is checked.
[Setting]:	Detects the specified bus mastership condition.
[Probes]:	Select the status of probe signals.
[Don't care]:	Detects no probe signal condition when this box is checked.
[Setting]:	Detects the specified probe signal condition. Don't care: Detects no selected probe condition. High: The status of the probe signal is high. Low: The status of the probe signal is low.
[IRQ]:	Sets an IRQ signal condition.
[Don't care]:	Detects no IRQ signal condition when this box is checked.
[Setting]:	Detects the specified IRQ signal condition. Don't care: Detects no selected IRQ signal condition. High: The status of the IRQ signal is high. Low: The status of the IRQ signal is low.
[Timestamp]:	Specify the time stamp value for bus cycles.
[Don't care]:	Detects no time stamp value when this box is checked.
[Setting]:	Detects the specified time stamp value. Enter a time stamp value.

Clicking the [OK] button after setting conditions in those pages stores the settings and starts searching. Clicking the [Cancel] button closes this dialog box without setting of conditions.

When a trace record that matches the search conditions is found, the line for the trace record will be highlighted. When no matching trace record is found, a message dialog box will appear.

Only the trace information that satisfies all the conditions set in above pages will be searched.

If a find operation is successful, selecting [Find Next] from the popup menu will move to the next found item.

3.8.5 Clearing the Trace Information

Select [Clear] from the popup menu to empty the trace buffer that stores the trace information. If several [Trace] windows are open, all [Trace] windows will be cleared as they all access the same buffer.

3.8.6 Saving the Trace Information in a File

Select [Save...] from the popup menu to open the [Save As] file dialog box, which allows the user to save the information displayed in the [Trace] window as a text file. A range can be specified based on the [PTR] number (saving the complete buffer may take several minutes). Note that this file cannot be reloaded into the [Trace] window.

Note: In filtering of trace information, the range to be saved cannot be selected. All the trace information displayed in the [Trace] window after filtering will be saved. Select a filtering range on the [General] page in the [Trace Filter] dialog box if you want to save the selected range. For details on the filtering function, refer to section 3.8.11, Extracting Records from the Acquired Information.

3.8.7 Viewing the [Editor] Window

The [Editor] window corresponding to the selected trace record can be displayed in the following two ways:

- Select a trace record and choose [View Source] from the popup menu.
- Double-click a trace record

The [Editor] or [Disassembly] window opens and the selected line is marked with a cursor.

3.8.8 Trimming the Source

Choose [Trim Source] from the popup menu to remove the white space from the left side of the source.

When the white space is removed, a check mark is shown to the left of the [Trim Source] menu. To restore the white space, choose [Trim Source] while the check mark is shown.

3.8.9 Temporarily Stopping Trace Acquisition

To temporarily stop trace acquisition during execution of the user program, select [Halt] from the popup menu. This stops trace acquisition and updates the trace display. Use this method to check the trace information without stopping execution of the user program.

3.8.10 Restarting Trace Acquisition

To restart trace acquisition being stopped during execution of the user program, select [Restart] from the popup menu.

3.8.11 Extracting Records from the Acquired Information

Use the filtering function to extract the records you need from the acquired trace information. The filtering function allows the trace information acquired by hardware to be filtered by software. Unlike the settings made in the [Trace Acquisition] dialog box for acquiring trace information by conditions, changing the settings for filtering several times to filter the acquired trace information allows easy extraction of necessary information, which is useful for analysis of data. The content of the trace buffer will not be changed even when the filtering function is used. Acquiring useful information as much as possible by the [Trace Acquisition] settings improves the efficiency in analysis of data because the capacity of the trace buffer is limited.

Use the filtering function in the [Trace Filter] dialog box to select a range for filtering.

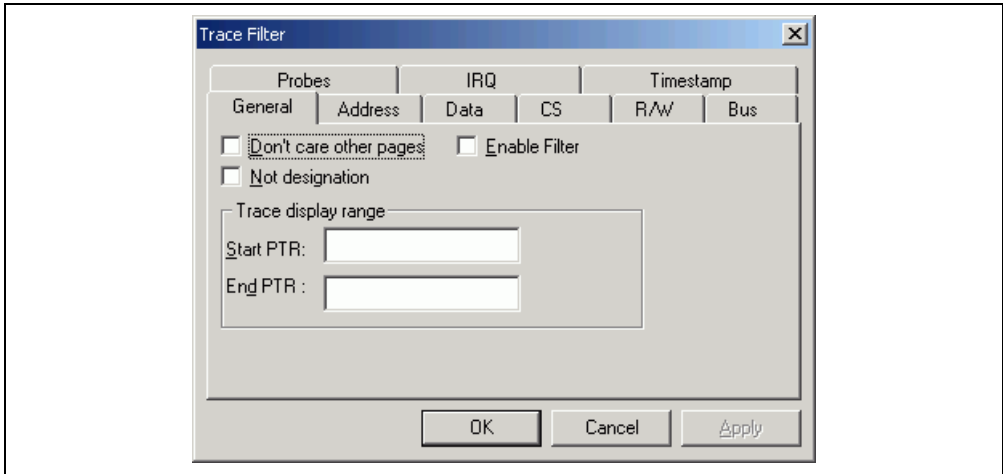

Figure 3.29 [Trace Filter] Dialog Box ([General] Page)

To open the [Trace Filter] dialog box, select [Filter...] from the popup menu.

The [Trace Filter] dialog box has the following pages:

[General]: Sets the range for filtering.

[Don't care other pages]: Only selects the cycle number when this box is checked. Other options become invalid.

[Enable Filter]: Enables the filter when this box is checked.

[Not designation]: Filters information that does not match the conditions set in those pages when this box is checked.

[Start PTR]: Enter a PTR value to start filtering.

[End PTR]: Enter a PTR value to end filtering.

[Address]: Set an address condition.

[Don't care]: Filters no address when this box is checked.

[Setting]: Detects the specified address.

[Point]: Enter a single address value.

[Range]:	Specify an address range.
[From]:	Enter a single address value or the start of the address range.
[To]:	Enter the end of the address range.
[Data]:	Set a data condition.
[Don't care]:	Filters no data when this box is checked.
[Setting]:	Detects the specified data.
[Point]:	Enter a single data value.
[Range]:	Specify a data range.
[From]:	Enter a single data value or the minimum value of the data range.
[To]:	Enter the maximum value of the data range.
[CS]:	Set a CS condition. (No CS condition can be set in the SH7059 E6000H emulator.)
[Don't care]:	Filters no CS when this box is checked.
[Setting]:	Detects the specified CS.
[R/W]:	Select the type of access cycles.
[Don't care]:	Detects no read/write condition when this box is checked.
[Setting]:	Detects the specified read/write condition.
	[RD]: Detects read cycles.
	[WR]: Detects write cycles.
[Bus]:	Set a bus mastership condition.
[Don't care]:	Detects no bus mastership condition when this box is checked.
[Setting]:	Detects the specified bus mastership condition.
[Probes]:	Select the status of probe signals.
[Don't care]:	Detects no probe signal condition when this box is checked.
[Setting]:	Detects the specified probe signal condition.
	Don't care: Detects no selected probe condition.
	High: The status of the probe signal is high.
	Low: The status of the probe signal is low.
[Timestamp]:	Specify the time stamp value for bus cycles.
[Don't care]:	Detects no time stamp value when this box is checked.
[Setting]:	Detects the specified time stamp value.
[Point]:	Specify a single time stamp value.
[Range]:	Specify a time stamp range.

[From]: Enter a single time stamp value or the minimum value of the time stamp range.

[To]: Enter the maximum value of the time stamp range.

Set filtering conditions and then press the [OK] button. This starts filtering according to the conditions. Clicking the [Cancel] button closes the [Trace Filter] dialog box, which holds the settings at the time when the dialog box was opened.

In filtering, only the trace information that satisfies one or more filtering conditions set in the above pages will be displayed in the [Trace] window.

Filtering conditions can be changed several times to analyze data because the content of the trace buffer is not changed by filtering.

3.8.12 Calculating the Difference in Time Stamping

Select [Timestamp Difference...] from the popup menu to calculate the time difference between the two points selected by the result of tracing in acquisition of time stamp information.

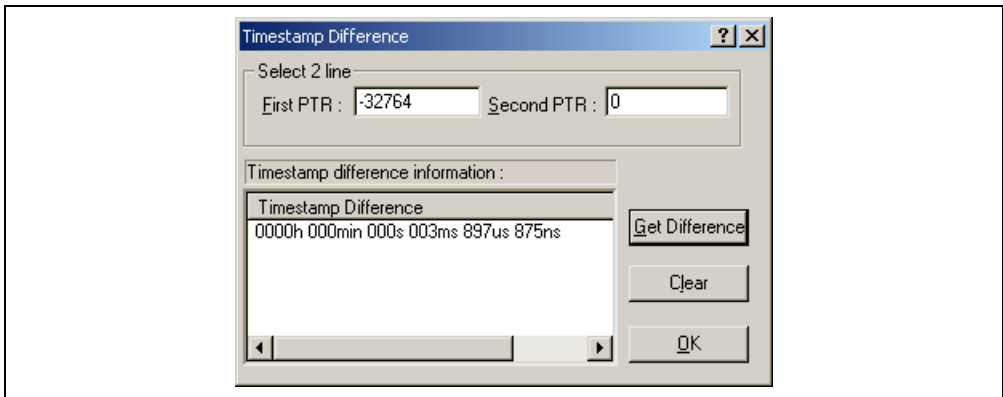

Figure 3.30 [Timestamp Difference] Dialog Box

[Select 2 line]: Select trace records to calculate the time stamp difference.

[First PTR]: Specifies the first pointer to measure the difference. The pointer of the line selected on the [Trace] window is displayed by default.

[Second PTR]: Specifies the second pointer to measure the difference.

[Timestamp Difference]: Displays the results of calculation.

[Get Difference]: Calculates the difference between the specified two points and display its result in the [Timestamp Difference] list.

[Clear]: Clears all the results in the [Timestamp Difference] list.

[OK]: Closes the dialog box. All the results in the [Timestamp Difference] list are cleared.

3.8.13 Analyzing Statistical Information

Choose [Statistic] from the popup menu to open the [Statistic] dialog box and analyze statistical information under the specified conditions.

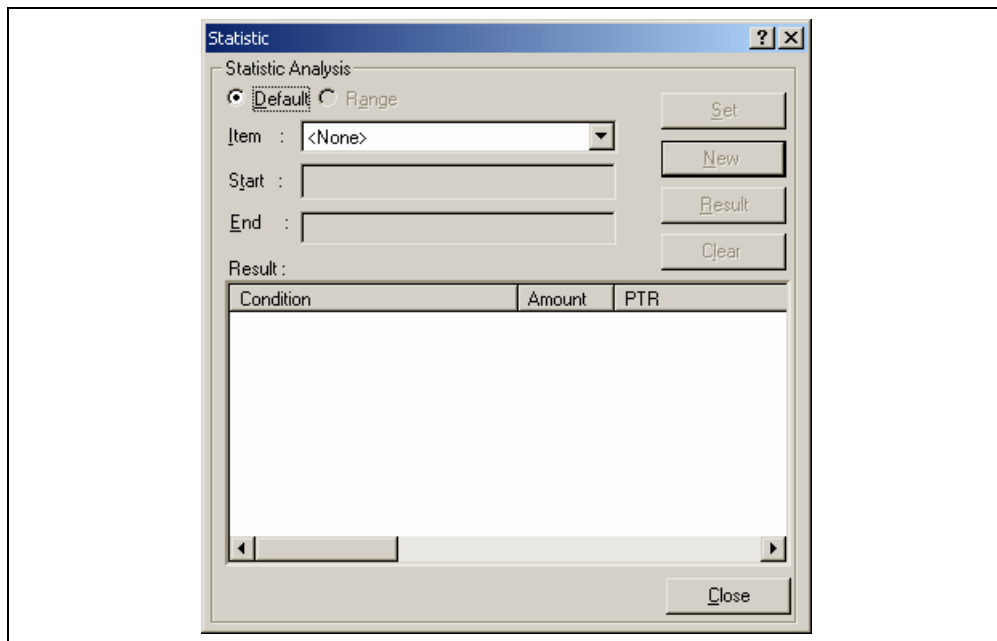

Figure 3.31 [Statistic] Dialog Box

- [Statistic Analysis]: Setting required for analysis of statistical information.
- [Default]: Sets a single input value or character string.
- [Range]: Sets the input value or character string as a range.
- [Item]: Sets the item for analysis.
- [Start]: Sets the input value or character string. To set a range, the start value must be specified here.
- [End]: Specify the end value if a range has been set (only available when [Range] has been selected).
- [Set]: Adds a new condition to the current one.
- [New]: Creates a new condition.
- [Result]: Obtains the result of statistical information analysis.
- [Clear]: Clears all conditions and results of statistical information analysis.
- [Close]: Closes this dialog box. All the results displayed in the [Result] list will be cleared.

This dialog box allows the user to analyze statistical information concerning the trace information. Set the target of analysis in [Item] and the input value or character string by [Start] and [End]. Click the [Result] button after setting a condition by pressing the [New] or [Add] button to analyze the statistical information and display its result in the [Result] list.

Note: In this emulator, only [PTR] can be set as a range. Each of other items must be specified as a character string. In analysis of statistical information, character strings are compared with those displayed in the [Trace] window. Only those that completely match are counted. Note, however, that this test is not case sensitive. The number of blanks will not be cared either.

3.8.14 Extracting Function Calls from the Acquired Trace Information

To extract function calls from the acquired trace information, select [Function Call...] from the popup menu. The [Function Call Display] dialog box will be displayed.

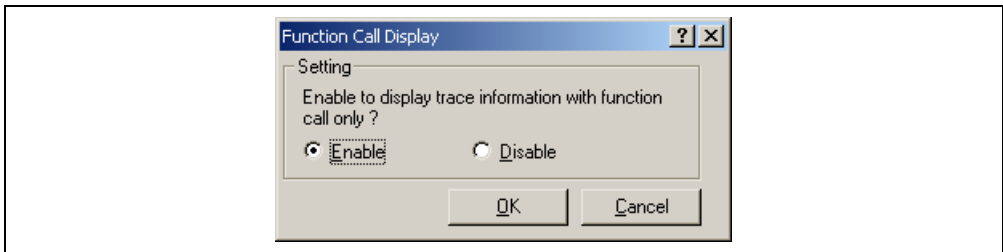

Figure 3.32 [Function Call Display] Dialog Box

[Setting]: Selects whether or not to extract function calls.

[Enable]: Extracts function calls.

[Disable]: Does not extract function calls.

When [Enable] is selected, only the cycles that include function calls are extracted for display from the acquired trace information. The content of the trace buffer is not changed by extraction of function calls. Using this function for the result of the free trace or the trace information that includes function calls allows the user to know the order of function calls.

3.9 Analyzing Performance

Use the performance analysis function to measure the rate of execution time. The performance analysis function does not affect the realtime operation because it measures the rate of execution time in the specified range by using the circuit for measurement of hardware performance included in the emulator.

Select one of the following five modes according to the purpose of measurement.

Table 3.1 Available Measurement Modes

Mode	Description	Purpose
Time Of Specified Range Measurement	Measures the execution time and execution count in the specified range.	Measurement of time taken for processing of functions except for that required for child functions called from the functions.
Start Point To End Point Measurement	Measures the execution time and execution count between the specified addresses.	Measurement of time taken for processing of functions.
Start Range To End Range Measurement	Measures the execution time from a specified range to another specified range.	Measurement of execution time spent from calling of any of sequential subroutines to calling of any of other sequential subroutines in a program that includes subroutines in sequence, such as an assembly program.
Access Count Of Specified Range Measurement	Measures the number of times a specified range is accessed from another specified range.	Measurement of the number of times a global variable is accessed from a specific function.
Called Count Of Specified Range Measurement	Measures the number of times a specified range has called another specified range.	Measurement of the number of times a function is called from a specific function.

Use eight performance channels installed on the circuit for measurement of hardware performance in the emulator for setting of conditions for measurement. Up to eight points can be set.

Note, however, that up to four points can be set in Start Range To End Range Measurement, Access Count Of Specified Range Measurement, or Called Count Of Specified Range Measurement because two sequential points are used for setting a condition in these modes.

Table 3.2 Mode Settings for Measurement

Measurement Mode	Point							
	1	2	3	4	5	6	7	8
Time Of Specified Range Measurement	0	0	0	0	0	0	0	0
Start Point To End Point Measurement	0	0	0	0	0	0	0	0
Start Range To End Range Measurement	0	—	0	—	0	—	0	—
Access Count Of Specified Range Measurement	0	—	0	—	0	—	0	—
Called Count Of Specified Range Measurement	0	—	0	—	0	—	0	—

Note: 0: Available
—: Not available

Note: Only one point is used in Time Of Specified Range Measurement and Start Point To End Point Measurement, while two sequential points are used in Start Range To End Range Measurement, Access Count Of Specified Range Measurement, and Called Count Of Specified Range Measurement. The conditions that have been set will be canceled when switching these modes of different types.

3.9.1 Opening the [Performance Analysis] Window

Choose [View -> Performance -> Performance Analysis] or click the [PA] toolbar button  to open the [Select Performance Analysis Type] dialog box.

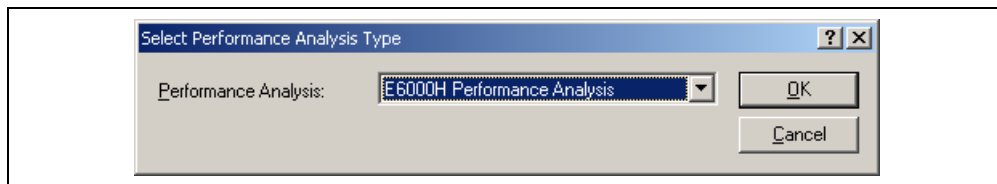
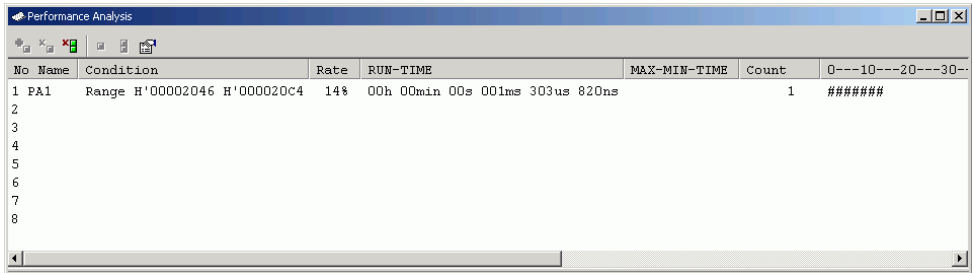

Figure 3.33 [Select Performance Analysis Type] Dialog Box

Select [E6000H Performance Analysis] and then click the [OK] button to open the [Performance Analysis] window.



No	Name	Condition	Rate	RUN-TIME	MAX-MIN-TIME	Count	0---10---20---30--
1	PA1	Range H'00002046 H'000020c4	14%	00h 00min 00s 001ms 303us 820ns		1	#####
2							
3							
4							
5							
6							
7							
8							

Figure 3.34 [Performance Analysis] Window

This window displays the rate of execution time in the area selected by the user during the last program run in percentages, histogram, or numerical values.

It is possible to hide any column not necessary in the [Performance Analysis] window. Selecting a column you want to hide from the popup menu displayed by clicking the right-hand mouse button on the header column hides that column. To display the hidden column, select the column from the said popup menu again.

3.9.2 Setting Conditions for Measurement

Conditions for measurement can be displayed and changed in the [Performance Analysis] window. Select a point where a condition is to be set, and then select [Set...] from the popup menu to display the [Performance Analysis Properties] dialog box.

Select either from the following five modes as the condition by the [Measurement Method] option:

Table 3.3 Conditions for Measurement (Measurement Method)

[Measurement Method] Option
Time Of Specified Range Measurement
Start Point To End Point Measurement
Start Range To End Range Measurement
Access Count Of Specified Range Measurement
Called Count Of Specified Range Measurement

Set a condition for measurement according to the mode being selected. The parameters to be set depend on the modes.

The [Performance Analysis Properties] window has a support function to enter the address range of a function automatically if the name of the function is entered to set an address range. Entering a function name in the [Input Function Range] dialog box displayed by clicking the [...] button on the [Performance Analysis Properties] dialog box automatically enters the address range of the function.

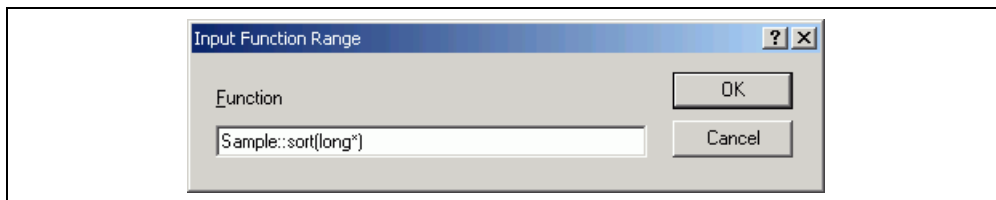
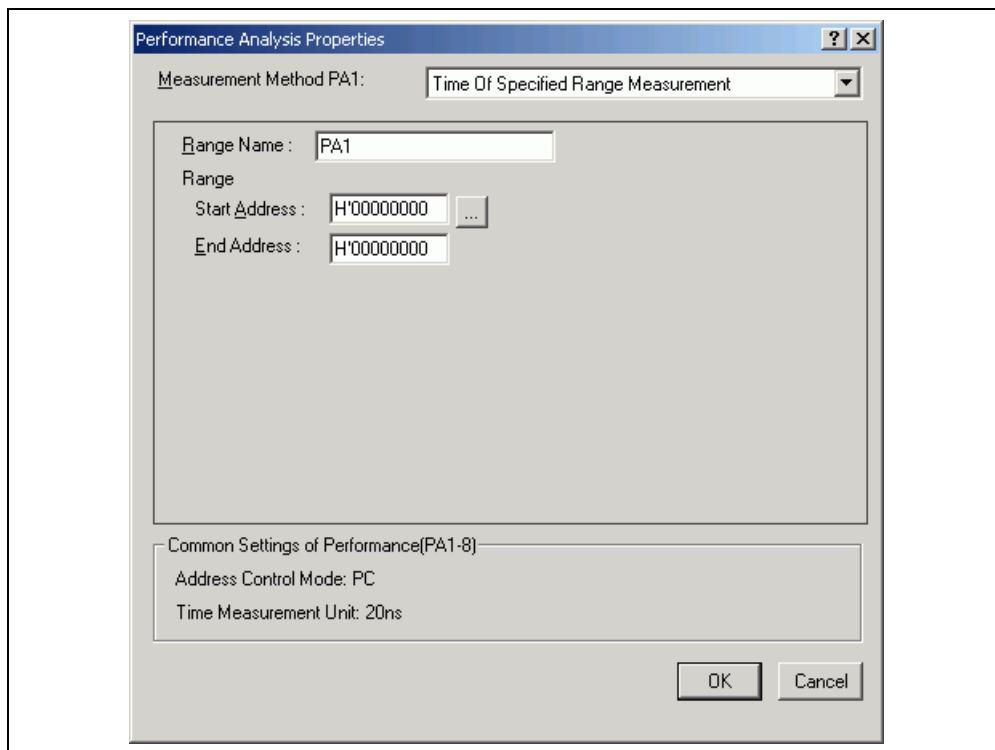

Figure 3.35 [Input Function Range] Window

- Notes:
1. Entering the name of an overload function or a class opens the [Select Function] dialog box. Select a function in this dialog box.
 2. The addresses figured out are just for reference. In some cases, the end address of a function may be different. Check the last instruction of the function in the [Disassembly] window to correct the value set in [End Address] so that it will be the address of the last instruction (in general, the last instruction of a function is a RTS instruction). A label name or an expression can be entered instead of an address value in boxes where an address should be entered.

(1) Time Of Specified Range Measurement

**Figure 3.36 Time Of Specified Range Settings**

[Range Name]: The name of the range to be measured

[Range]: The range for the Time Of Specified Range Measurement

[Start Address]: Address to start measurement

[End Address]: Address to end measurement

Measures the execution time and the execution count in the range between the start address and end address. Starts measurement with a detected program prefetch in the range specified between the start and end addresses, and then stops with a detected program prefetch out of the specified range. Measurement can be restarted with a detected program prefetch in the specified range. The execution count is incremented every time the program is prefetched at the end address of the specified range. The execution time measured does not include the time spent while being called from the specified range.

(2) Start Point To End Point Measurement

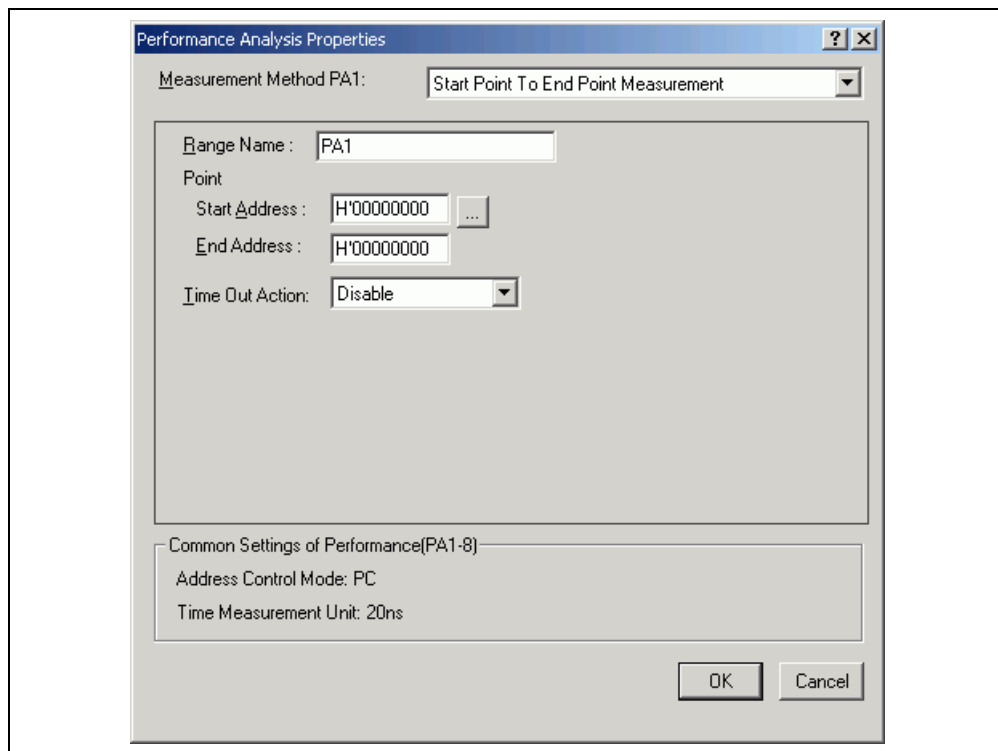

Figure 3.37 Start Point To End Point Measurement Settings

[Range Name]: The name of the range to be measured

[Point]: The range for the Start Point To End Point Measurement

[Start Address]: Address to start measurement

[End Address]: Address to end measurement

[Time Out Action]: The action to take when a timeout or count-out occurs.

Disable: Disables setting of a timeout or count-out value.

Enable: Stops the user program execution when a timeout or count-out occurs.

Trace Stop: Stops trace acquisition when a timeout or count-out occurs.

This is only available for channel 1.

[Time Out]: The timeout value to finish measurement. When the minimum time for measurement is 160 ns, 40 ns, or 20 ns, enter the value as follows.

Example: 1h 2min 3s 123ms 456us 789ns

If the CPU operating mode is target, enter a hexadecimal number in 10 digits.

Example: 123456789A

A break occurs every time a value measured in the specified range exceeds the timeout value (not the total time). This is only available for channel 1.

[Count]: The count-up value used in measurement of the execution count. A break occurs every time the execution count exceeds the count-up value. This is only available for channel 1.

Measures the execution time and the execution count in the range between start address and end address. Starts measurement with a detected program prefetch at the start address, and then stops with a detected program prefetch at the end address. The execution count is incremented every time the program is prefetched at the end address of the specified range. The execution time measured includes the time spent while being called from the specified range. When either from one to four points is selected, the maximum and minimum time in the specified range can be measured.

(3) Start Range To End Range Measurement

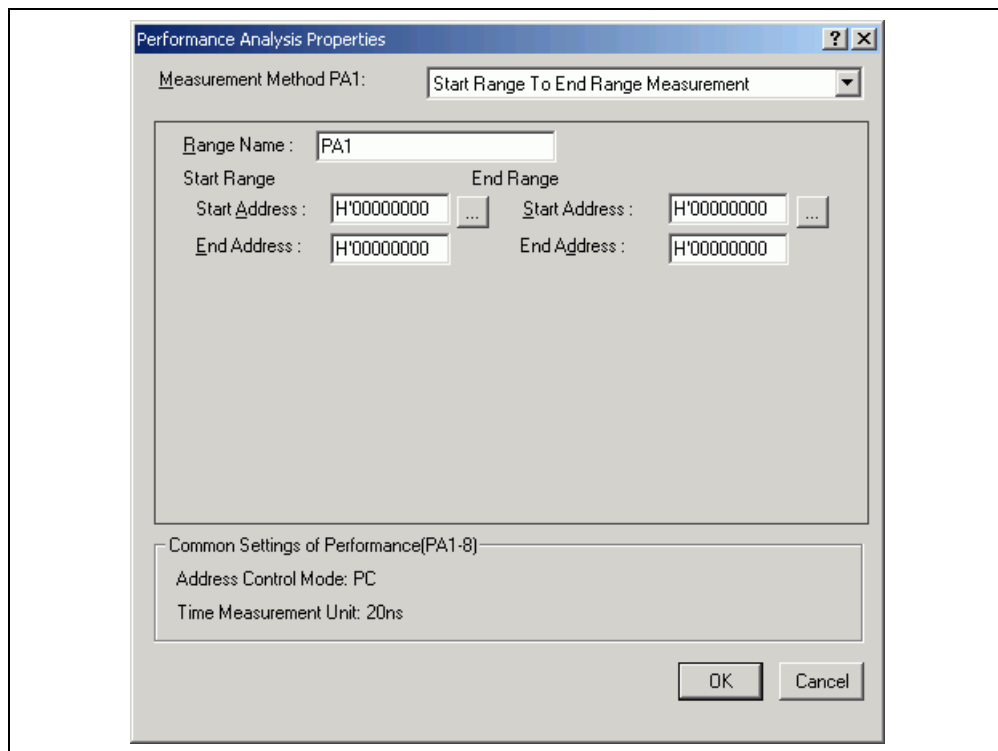

Figure 3.38 Start Range To End Range Measurement Settings

[Range Name]:	The name of the range to be measured
[Start Range]:	The start range for the Start Range To End Range Measurement
[Start Address]:	Start address
[End Address]:	End address
[End Range]:	The end range for the Start Range To End Range Measurement
[Start Address]:	Start address
[End Address]:	End address

Starts measurement with a detected prefetch cycle in the specified start address range, and then stops with a detected prefetch cycle in the specified end address range. The execution count is incremented every time the program passes the end address range.

(4) Access Count Of Specified Range Measurement

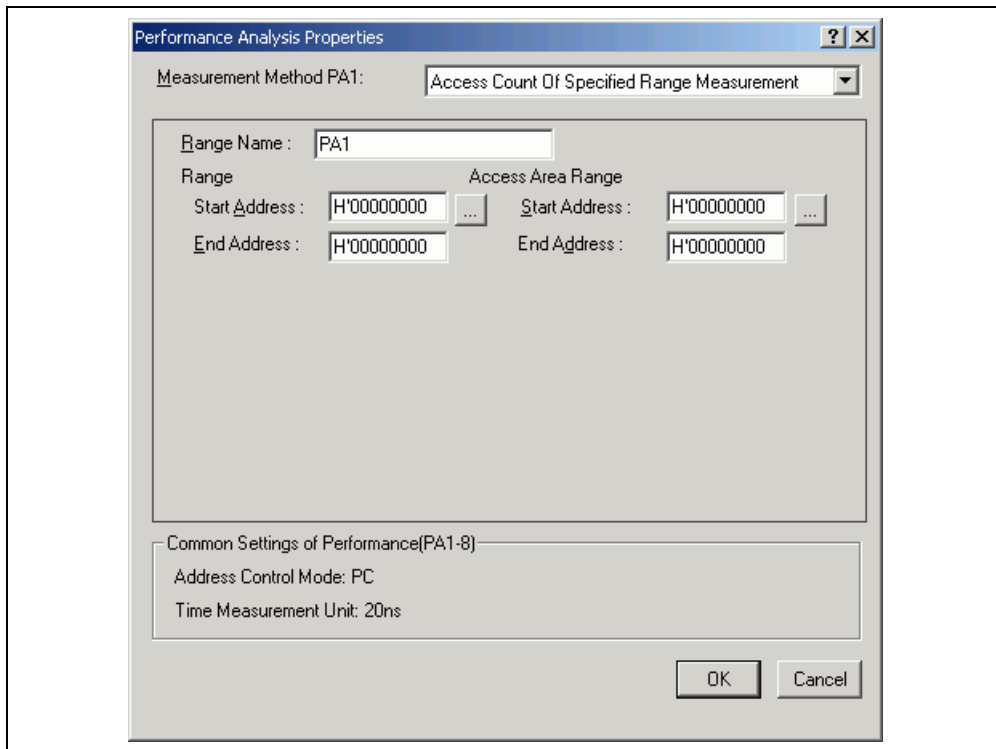

Figure 3.39 Access Count Of Specified Range Measurement Settings

[Range Name]: The name of the range to be measured

[Range]: The range for the Access Count Of Specified Range Measurement

[Start Address]: Start address

[End Address]: End address

[Access Area Range]: The access range for the Access Count Of Specified Range Measurement

[Start Address]: Start address

[End Address]: End address

Measures the number of times the range specified as the access range is accessed from the range specified by the start and end addresses. The execution count in the range is measured with Time Of Specified Range Measurement mode.

(5) Called Count Of Specified Range Measurement

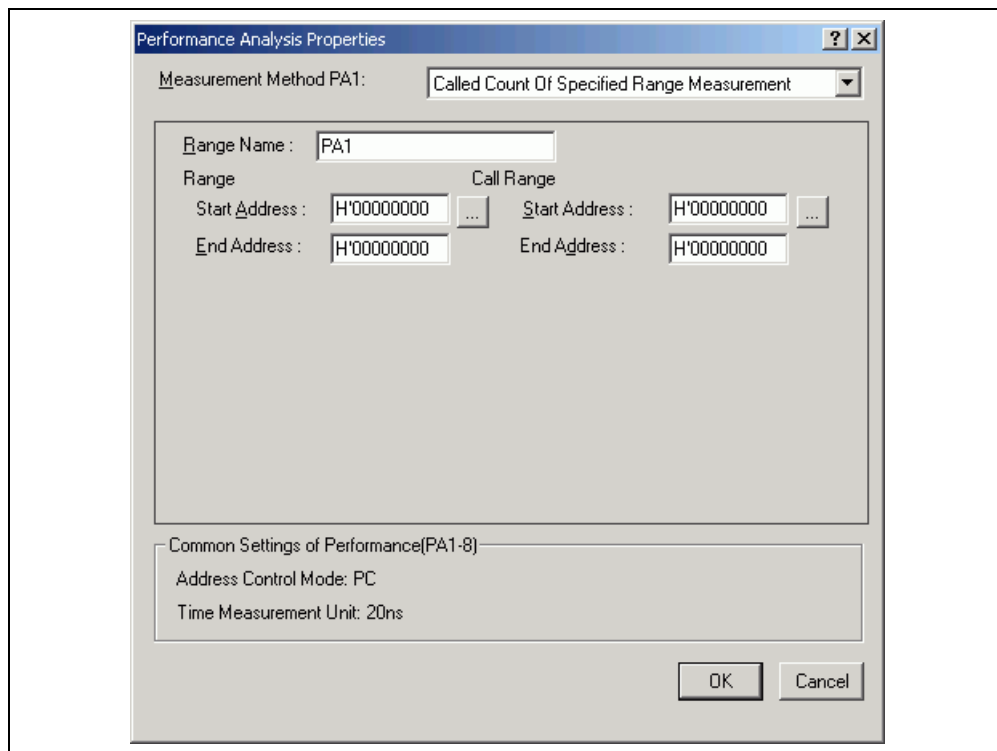

Figure 3.40 Called Count Of Specified Range Measurement Settings

- [Range Name]: The name of the range to be measured
- [Range]: The range for the Called Count Of Specified Range Measurement
- [Start Address]: Start address
- [End Address]: End address
- [Call Range]: The range for the Called Count Of Specified Range Measurement. As the call range, specify the start and end addresses of the selected subroutine.
- [Start Address]: Start address
- [End Address]: End address

Measures the number of times the range specified as the call range is called from the range specified by the start and end addresses. The execution time in the specified range can be measured with Time Of Specified Range Measurement mode. As the call range, specify the start and end addresses of the selected subroutine.

3.9.3 Starting Performance Data Acquisition

Executing the user program clears the result of previous measurement and automatically starts measuring the rate of execution time according to the conditions that have been set. Stopping the user program displays the result of measurement in the [Performance Analysis] window.

3.9.4 Deleting a Measurement Condition

Select [Reset] from the popup menu with a measurement condition selected to delete the condition.

3.9.5 Deleting All Measurement Conditions

Choose [Reset All] from the popup menu to delete all the conditions that have been set.

3.10 Profiling Function

3.10.1 Enabling the Profile

Choose [View->Performance->Profile] to open the [Profile] window. Choose [Enable Profiler] from the popup menu of the [Profile] window. The item on the menu will be checked.

3.10.2 Specifying Measuring Mode

You can specify whether to trace functions calls while profile data is acquired. When function calls are traced, the relations of function calls during user program execution are displayed as a tree diagram. When not traced, the relations of function calls cannot be displayed, but the time for acquiring profile data can be reduced.

To stop tracing function calls, choose [Disable Tree (Not traces function call)] from the popup menu in the [Profile] window (a check mark is shown to the left of the menu item).

When acquiring profile data of the program in which functions are called in a special way, such as task switching in the OS, stop tracing function calls.

3.10.3 Executing the Program and Checking the Results

After the user program has been executed and execution has been halted, the results of measurement are displayed in the [Profile] window.

The [Profile] window has two sheets; a [List] sheet and a [Tree] sheet.

3.10.4 [List] Sheet

The screenshot shows a window titled "Profile" with a toolbar containing icons for "Show Functions/Variables", "Data", and a pencil. Below the toolbar is a table with the following columns: Function/Variable, F/V, Address, Size, Times, and Cycles. The table lists several functions and variables, including _PowerON_Reset_PC, Sample::change(long *), Sample::sort(long *), Sample::Sample(), _rand, operator new(unsigned long), _CALL_INIT, _INITSTCT, tutorial(), and _main. At the bottom of the window, there are navigation arrows and a tab labeled "List" which is currently selected.

Function/Variable	F/V	Address	Size	Times	Cycles
_PowerON_Reset_PC	F	00000A00	H'0000002E	1	208
Sample::change(long *)	F	000020CE	H'0000006A	1	150
Sample::sort(long *)	F	00002032	H'0000009C	1	401
Sample::Sample()	F	00002000	H'00000032	1	145
_rand	F	00001228	H'0000002C	10	873
operator new(unsigned long)	F	000011C8	H'00000060	1	108
_CALL_INIT	F	00001178	H'00000028	1	77
_INITSTCT	F	00001110	H'00000000	1	293
tutorial()	F	00001054	H'000000A0	1	1205
_main	F	00001038	H'0000001C	1	52

Figure 3.41 [Profile] Window ([List] Sheet)

This window displays the address and size of a function or a global variable, the number of times the function is called or the global variable is accessed, and profile data.

When the column header is clicked, data are sorted in alphabetic or numeric ascending/descending order.

Double-clicking the [Function/Variable] or [Address] column displays the source program of the address in the line. Right-clicking on the mouse within the window displays a popup menu. For details on this popup menu, refer to section 3.10.5, [Tree] Sheet.

Note: For notes on the profiling function, refer to section 5.9, Profiling Function.

3.10.5 [Tree] Sheet

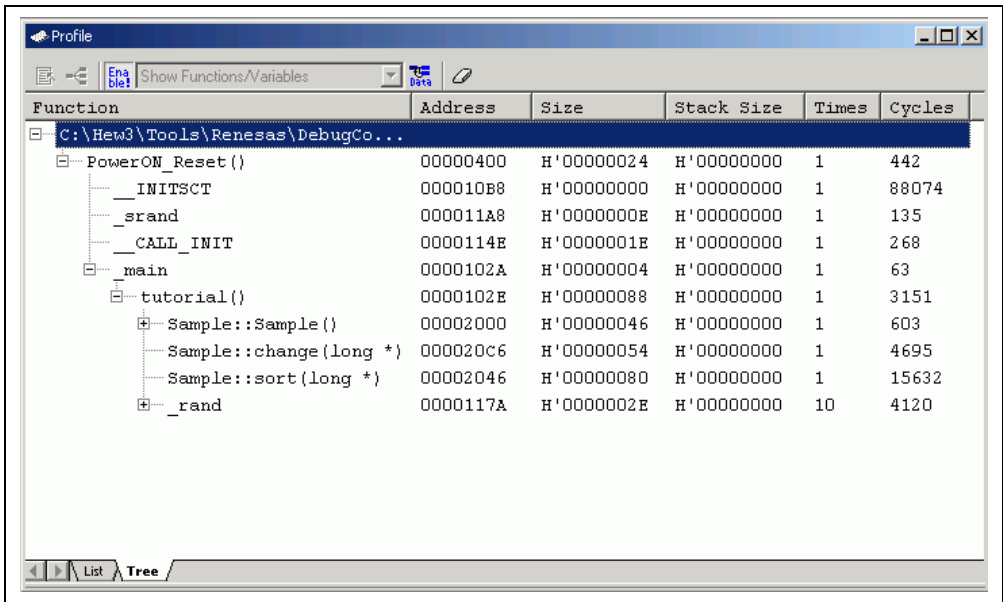

Function	Address	Size	Stack Size	Times	Cycles
[-] C:\Hew3\Tools\Renesas\DebugCo...					
[-] PowerON_Reset()	00000400	H'00000024	H'00000000	1	442
[-] __INIT\$CT	000010B8	H'00000000	H'00000000	1	88074
[-] __srand	000011A8	H'0000000E	H'00000000	1	135
[-] __CALL__INIT	0000114E	H'0000001E	H'00000000	1	268
[-] main	0000102A	H'00000004	H'00000000	1	63
[-] tutorial()	0000102E	H'00000088	H'00000000	1	3151
[-] Sample::Sample()	00002000	H'00000046	H'00000000	1	603
[-] Sample::change(long *)	000020C6	H'00000054	H'00000000	1	4695
[-] Sample::sort(long *)	00002046	H'00000080	H'00000000	1	15632
[-] __rand	0000117A	H'0000002E	H'00000000	10	4120

Figure 3.42 [Profile] Window ([Tree] Sheet)

This window displays the relation of function calls in a tree structure. Displayed contents are the address, size, stack size, and number of function calls and execution cycles. The stack size and number of function calls are values when the function is called.

The [Tree] sheet is only available when [Not trace the function call] is not checked in the popup menu of the [Profile] window.

Double-clicking a function in the [Function] column expands or reduces the tree structure display. The expansion or reduction is also provided by the “+” or “-” key. Double-clicking the [Address] column displays the source program of the specific address.

Right-clicking with the mouse within the window displays a popup menu. Supported menu options are described in the following sections:

- **View Source**

Displays the source program or disassembled memory contents for the address in the selected line.

- **View Profile-Chart**

Displays the [Profile-Chart] window focused on the function in the specified line.

- **Enable Profiler**

Toggles acquisition profile data. When profile data acquisition is active, a check mark is shown to the left of the menu text.

- **Not trace the function call**

Stops tracing function calls while profile data is acquired. This menu is used when acquiring profile data of the program in which functions are called in a special way, such as task switching in the OS.

To display the relation of function calls in the [Tree] sheet of the [Profile] window, acquire profile data without selecting this menu. In addition, do not select this menu when optimizing the program by the optimizing linkage editor using the acquired profile information file.

- **Find...**

Displays the [Find Text] dialog box to find a character string in the [Function] column. Search is started by inputting a character string to be found in the edit box and clicking [Find Next] or pressing the Enter key.

- **Find Data**

Displays the [Find Data] dialog box. Select the column to search in the [Column] combo-box and set the direction of the search in the [Data to Find] group box. Click on the [Find Next] button or press the Enter key to start the search. Also, consecutively pressing the [Search Next] button or the ENTER key leads to a search for the next larger value (if the value is a minimum, the search will be for the next smaller value).

- **Clear Data**

Clears the number of times functions are called and profile data. Data in the [Profile] window's [List] sheet and the [Profile-Chart] window are also cleared.

- **Output Profile Information Files...**

Displays the [Save Profile Information Files] dialog box. Profiling results are saved in a profile information file (.pro extension). The optimizing linkage editor optimizes user programs according to the profile information in this file. For details of the optimization using the profile information, refer to the manual of the optimizing linkage editor.

Note: If profile information has been acquired by selecting the [Not trace the function call] menu, the program cannot be optimized by the optimizing linkage editor.

- **Output Text File...**

Displays the [Save Text of Profile Data] dialog box. Displayed contents are saved in a text file.

- **Setting**

This menu has the following submenus (the menus available only in the [List] sheet are also included).

1. Show Functions/Variables

Displays both functions and global variables in the [Function/Variable] column.

2. Show Functions

Displays only functions in the [Function/Variable] column.

3. Show Variables

Displays only global variables in the [Function/Variable] column.

4. Only Executed Functions

Only displays the executed functions. If a stack information file (.sni extension) output from the optimizing linkage editor does not exist in the directory where the load module is located, only the executed functions are displayed even if this check box is not checked.

5. Include Data of Child Functions

Sets whether or not to display information for a child function called in the function as profile data.

- **Properties...**

This popup menu is unavailable in the E6000H emulator.

3.11 [Profile-Chart] Window

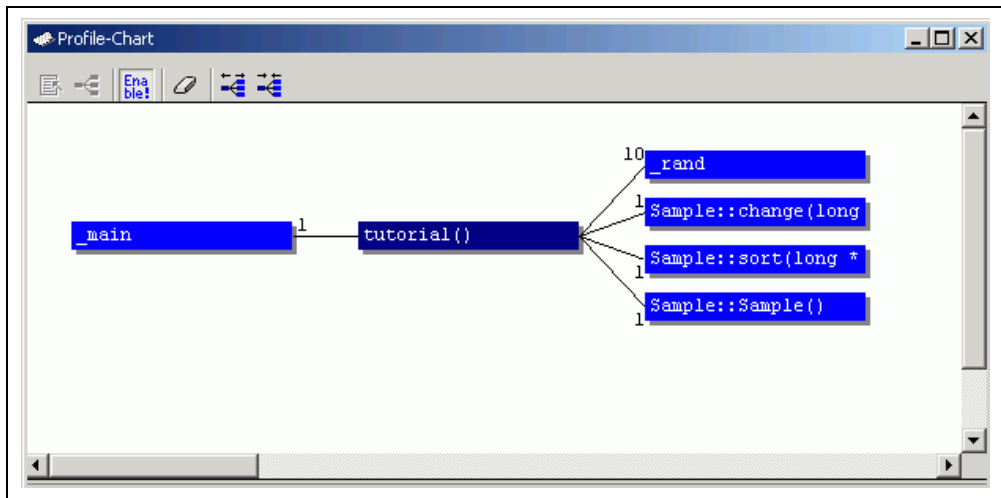

Figure 3.43 [Profile-Chart] Window

This window displays the relation of calls for a specific function. This window displays the calling relation for the function specified in the [List] sheet or [Tree] sheet in the [Profile] window. The specified function is displayed in the middle, the calling function on the left side, and the called function on the right side. Values beside the calling and called functions show the number of times the function has been called.

Right-clicking on the mouse within the window displays a popup menu. Supported menu options are described in the following sections.

- **View Source**

Displays the source program or disassembled memory contents for the address of the function on which the cursor is placed when the right-hand mouse button is clicked. If the cursor is not placed on a function when the right-hand mouse button is clicked, this menu option is displayed in gray characters.

- **View Profile-Chart**

Displays the [Profile-Chart] window for the specific function on which the cursor is placed when the right-hand mouse button is clicked. If the cursor is not placed on a function when the right-hand mouse button is clicked, this menu option is displayed in gray characters.

- **Enable Profiler**

Toggles acquisition of profile data. When profile data acquisition is active, a check mark is shown to the left of the menu text.

- **Clear Data**

Clears the number of times functions are called and profile data. Data in the [List] sheet and [Tree] sheet in the [Profile] window are also cleared.

- **Multiple View**

If the [Profile-Chart] window is going to be opened when it has already been opened, selects whether another window is to be opened or the same window is to be used to display data. When a check mark is shown to the left side of the menu text, another window is opened.

- **Output Profile Information File...**

Displays the [Save Profile Information File] dialog box. Profiling results are saved in a profile information file (.pro extension). The optimizing linkage editor optimizes user programs according to the profile information in this file. For details of the optimization using the profile information, refer to the manual of the optimizing linkage editor.

- **Expands Size**

Expands spaces between each function. The “+” key can also be used to expand spaces.

- **Reduces Size**

Reduces spaces between each function. The “-” key can also be used to reduce spaces.

Section 4 Tutorial

4.1 Introduction

This section describes the main functions of the emulator by using a tutorial program.

The tutorial program is based on the C++ program that sorts ten random data items in ascending or descending order. The tutorial program performs the following actions:

- The main function repeatedly calls the `tutorial` function to repeat sorting.
- The `tutorial` function generates random data to be sorted and calls the `sort` and `change` functions in that order.
- The `sort` function enters the array where the random data generated by the `tutorial` function are stored, and sorts them in the ascending order.
- The `change` function then sorts the array, which was sorted in ascending order by the `sort` function, in descending order.

The file `tutorial.cpp` contains the source code for the tutorial program. The file `Tutorial.abs` is a compiled load module in the Dwarf2 format.

- Notes:
1. After recompilation, the addresses may differ from those given in this section.
 2. This section describes general usage examples for the emulator. For the particular specifications of each product, refer to section 3, Debugging, or the online help.
 3. The operation address of `Tutorial.abs` attached to each product differs depending on the product. Replace the address used in this section with the correct address in each product after checking that it is placed on the corresponding line of the source program.
 4. In this tutorial, the SH7058 E6000H emulator is taken as an example. File paths or the appearance of figures differ depending on the product.

4.2 Running the High-performance Embedded Workshop

Open a workspace by following the procedure listed in section 2.1.3, Selecting an Existing Workspace.

Select the following directory.

OS installation drive \Workspace\Tutorial\E6000H\7058

Notes: 1. The directory mentioned above cannot be specified depending on the version of the software. In such cases, specify the following directory instead.

High-performance Embedded Workshop installation destination directory
\Tools\Renesas\DebugComp\Platform\E6000H\7058\Tutorial

2. The file path differs depending on the product. If necessary, replace \7058 with another name.

Then select the file indicated below.

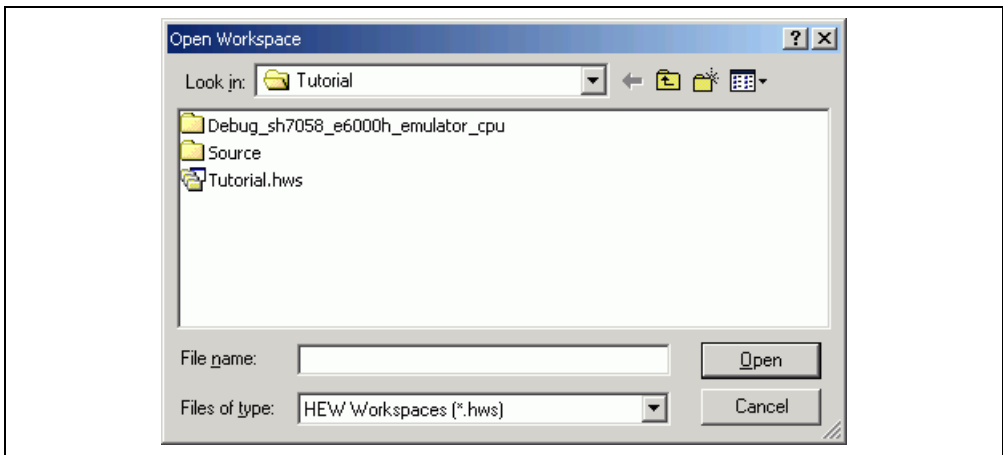

Figure 4.1 [Open Workspace] Dialog Box

4.3 Downloading the Tutorial Program

4.3.1 Downloading the Tutorial Program

Download the object program to be debugged.

- Select [Download module] from [Tutorial.abs] of [Download modules].

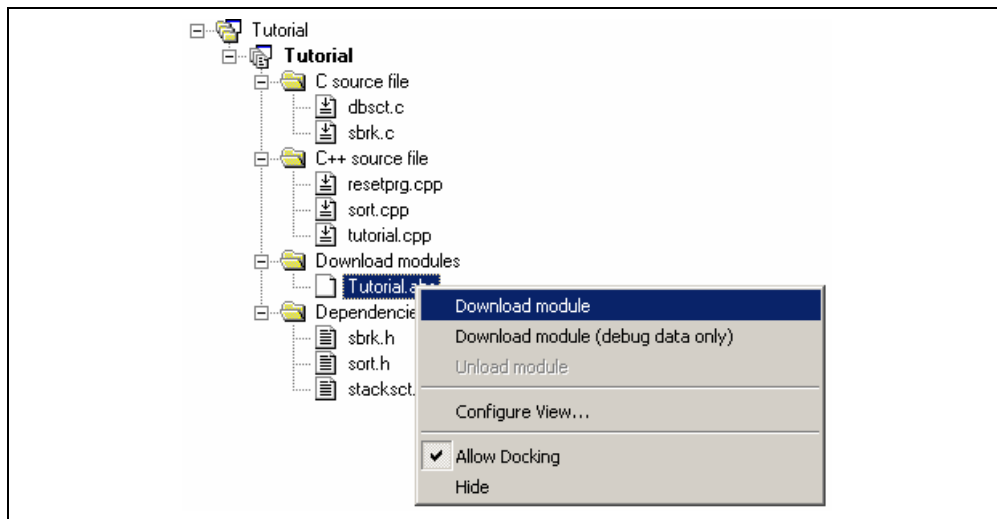

Figure 4.2 Downloading the Tutorial Program

4.3.2 Displaying the Source Program

The High-performance Embedded Workshop allows the user to debug a user program at the source level.

- Double-click [Tutorial.cpp] under [C++ source file].

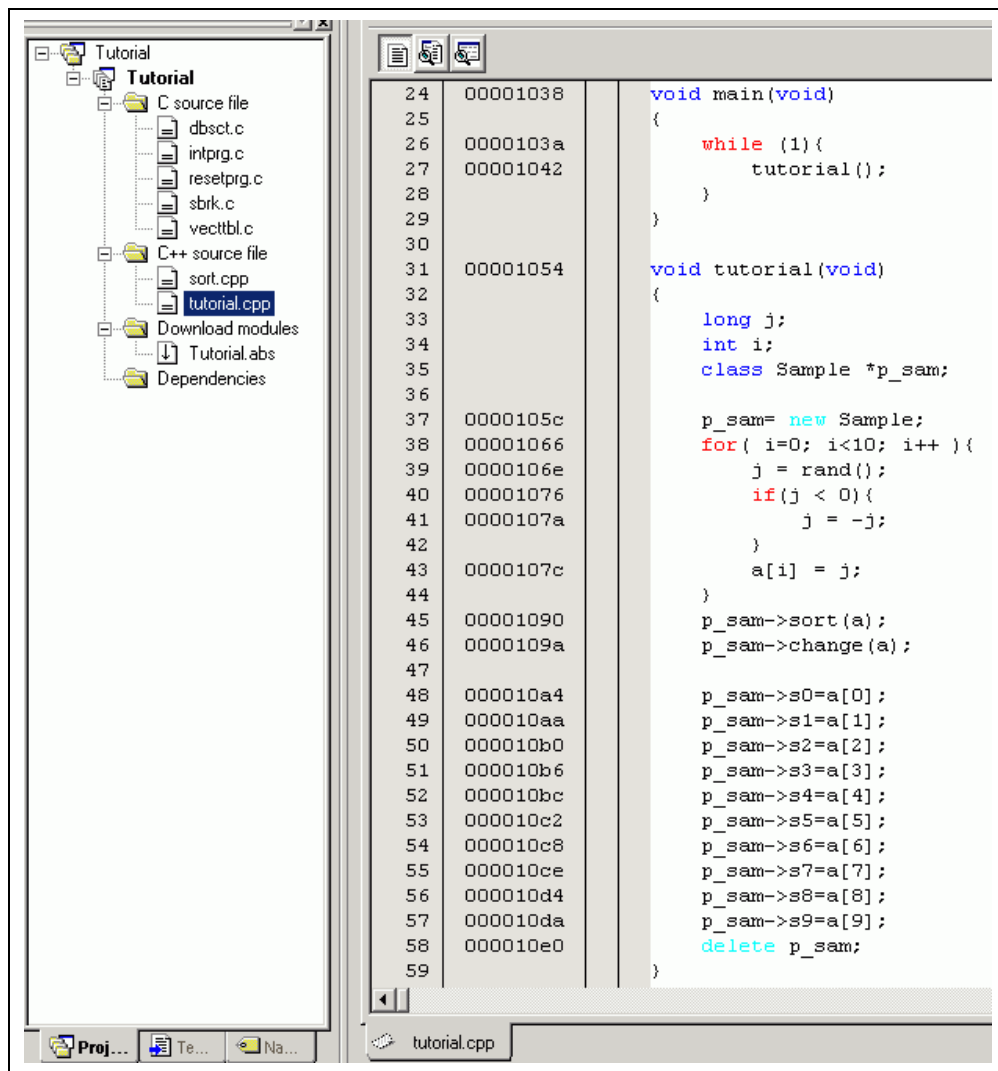

Figure 4.3 [Editor] Window (Displaying the Source Program)

- Select a font and size that are legible if necessary.

Initially the [Editor] window shows the start of the user program, but the user can use the scroll bar to scroll through the user program and look at the other statements.

4.4 Setting a Software Breakpoint

A software breakpoint is a simple debugging function.

The [Editor] window provides a very simple way of setting a software breakpoint at any point in a program. For example, to set a software breakpoint where the `sort` function is called:

- Select by double-clicking the [S/W Breakpoints] column on the line containing the `sort` function call.

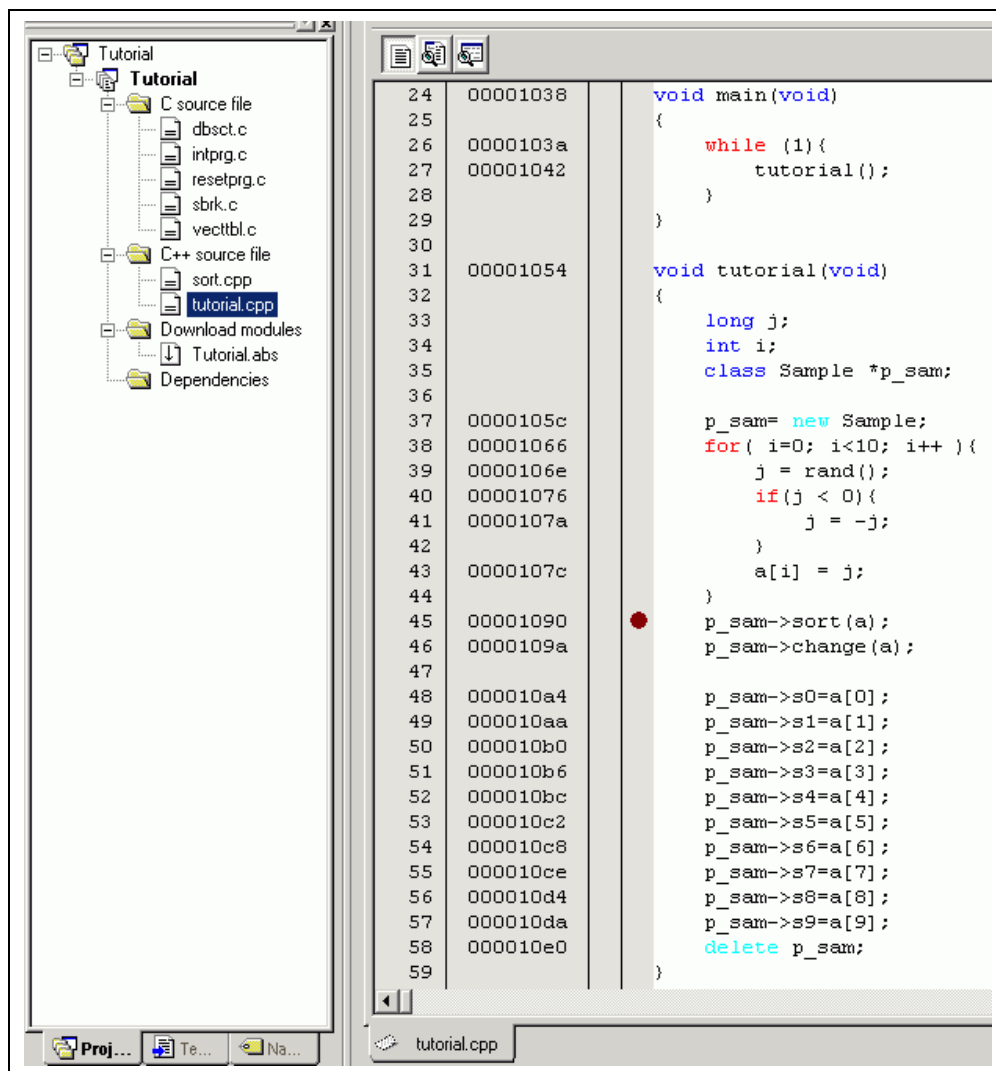



Figure 4.4 [Editor] Window (Setting a Software Breakpoint)

The symbol • will appear on the line containing the `sort` function. This shows that a software breakpoint has been set.

4.5 Setting Registers

Set a value in the program counter before executing the program.

- Select [Registers] from the [CPU] submenu of the [View] menu or click the [Register] toolbar button () to display the [Register] window.

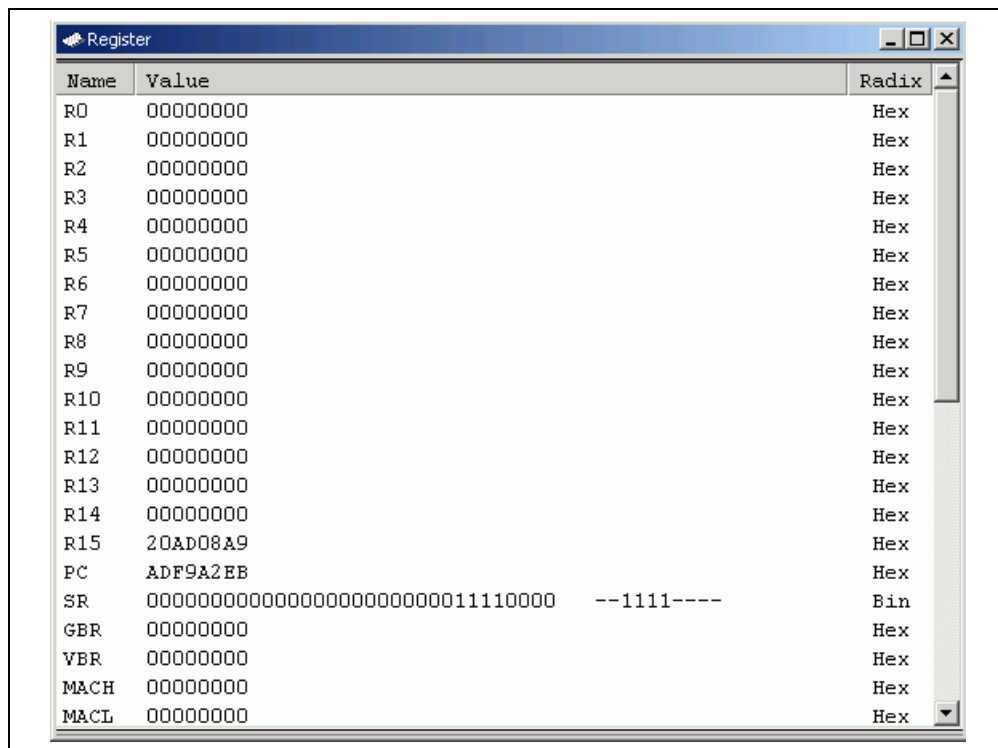

Figure 4.5 [Register] Window

- To change the value of the program counter (PC), double-click on the PC value area in the [Register] window with the mouse. The following dialog box is then displayed, and the value can be changed. Set the program counter to H'0000A00 in this tutorial program, and click the [OK] button.

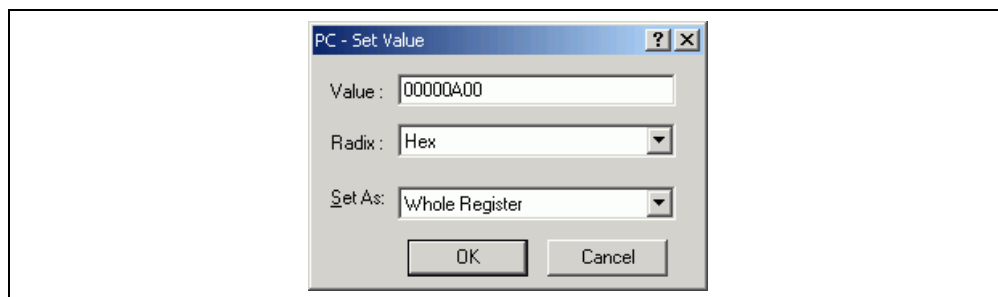

Figure 4.6 [Register] Dialog Box (PC)

4.6 Executing the Program

Execute the program as described in the following:

- To execute the program, select [Go] from the [Debug] menu, or click the [Go] button on the toolbar.



Figure 4.7 [Go] Button

While the program is executed, the current address bus value and the operating state of the MCU are displayed on the status bar.

The program will be executed up to the software breakpoint that has been set, and an arrow will appear on the [S/W Breakpoints] column in the [Editor] window to show the position where the program has halted, with the message [Break = Software Break] in the status bar.

Notes: 1. When the source file is displayed after a break, a path of the source file may be inquired. The location of the source file is as follows:

OS installation drive \Workspace\Tutorial\E6000H\7058\Source

The directory mentioned above cannot be specified depending on the version of the software. In such cases, specify the following directory instead.

High-performance Embedded Workshop installation destination directory
\Tools\Renesas\DebugComp\Platform\E6000H\7058\Source

2. The file path differs depending on the product. If necessary, replace \7058 with another name.

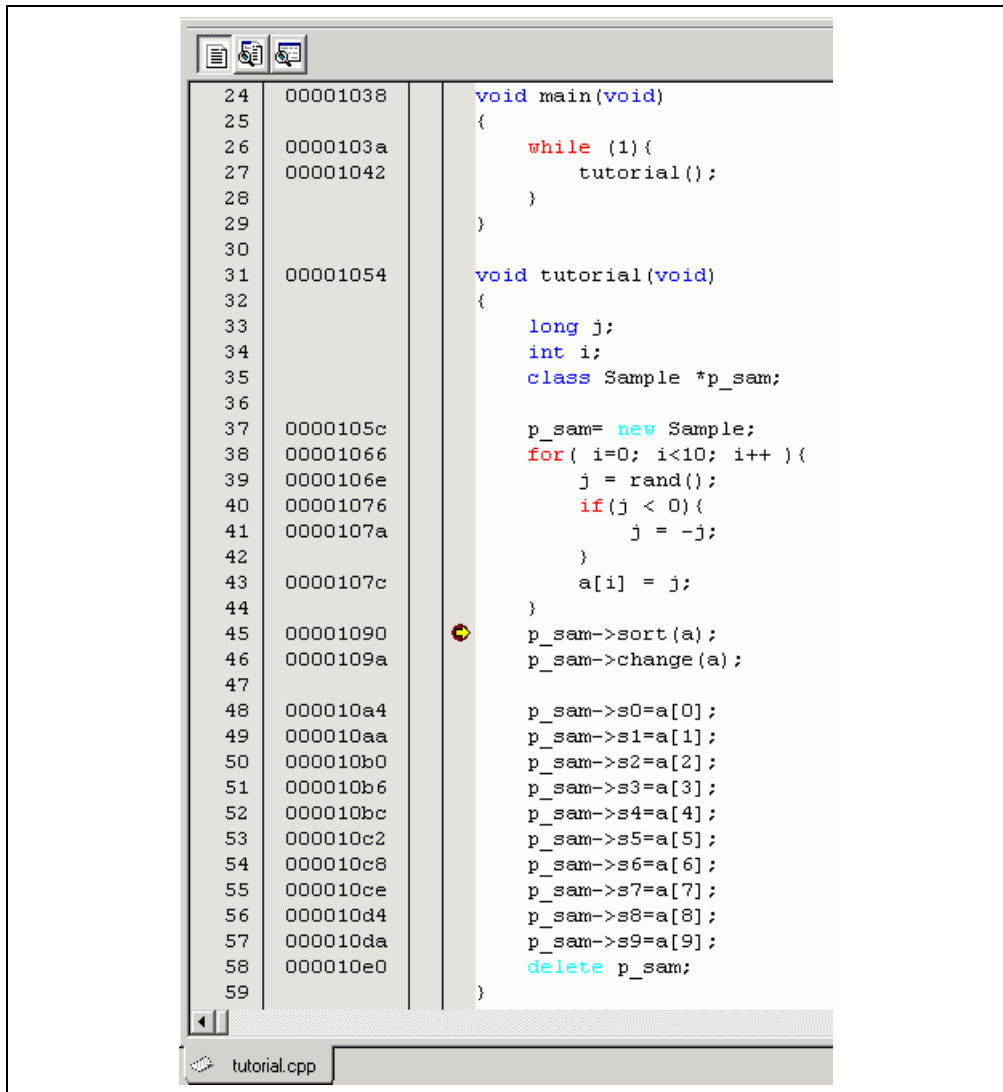



Figure 4.8 [Editor] Window (Break Status)

The user can see the cause of the break that occurred last time in the [Status] window.

- Select [Status] from the [CPU] submenu of the [View] menu or click the [Status] toolbar button . After the [Status] window is displayed, open the [Platform] sheet, and check the Status of Cause of last break.

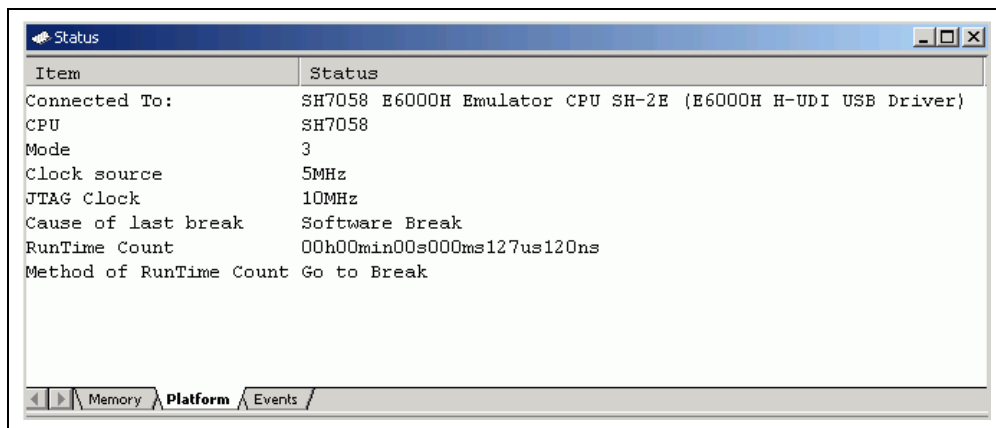



Figure 4.9 [Status] Window

Note: The items that can be displayed in this window differ depending on the product. For the items that can be displayed, refer to section 3, Debugging, or the online help.

4.7 Reviewing Breakpoints

The user can see all the breakpoints set in the program in the [Event] window.

- Select [Eventpoints] from the [Code] submenu of the [View] menu or click the [Eventpoints] toolbar button . The [Event] window is displayed. Select the [Software] sheet.

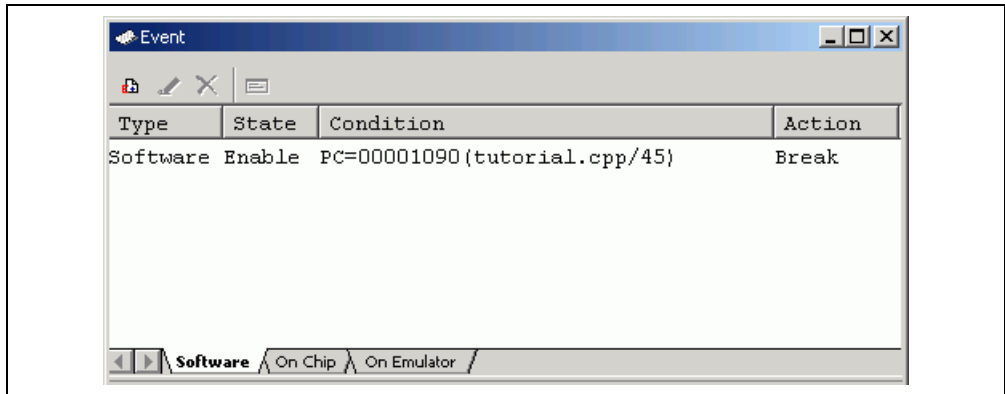

Figure 4.10 [Event] Window

The popup menu, opened by clicking the [Event] window with the right-hand mouse button, allows the user to set or change breakpoints, define new breakpoints, and delete, enable, or disable breakpoints.

4.8 Referring to Symbols

The [Label] window can be used to display the information on symbols in modules.

Select [Label] from the [Symbol] submenu of the [View] menu. The [Label] window is displayed so that the user can refer to the addresses of symbols in modules.

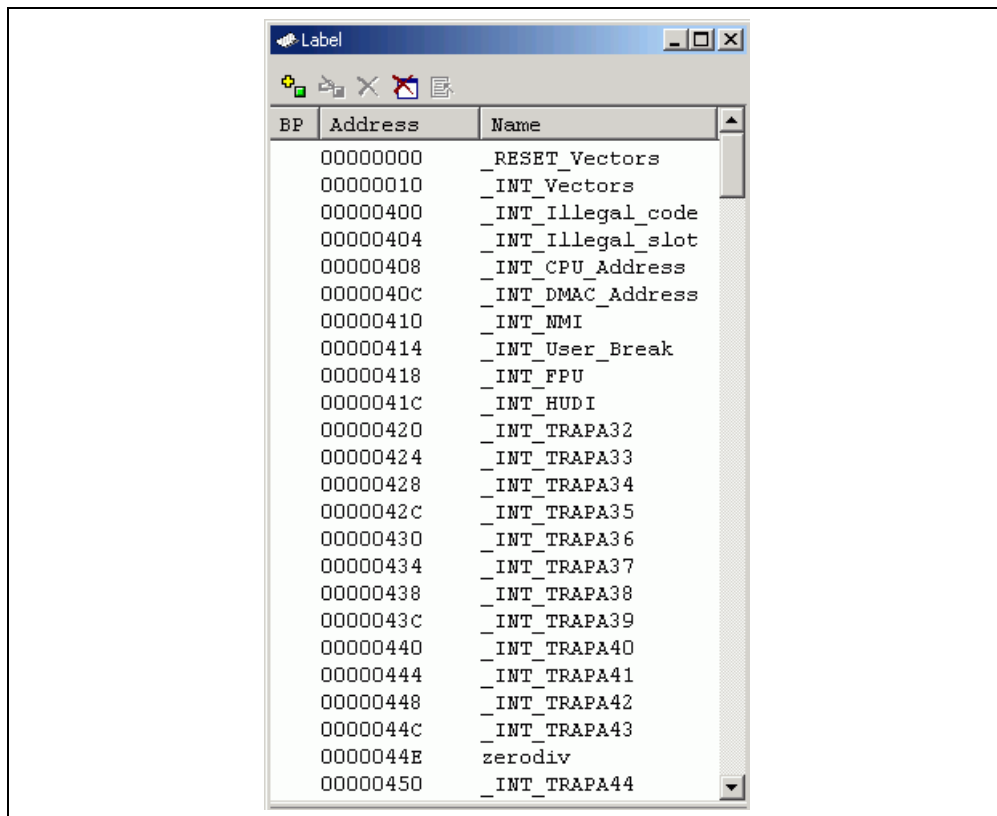



Figure 4.11 [Label] Window

4.9 Viewing Memory

When the label name is specified, the user can view the memory contents that the label has been registered in the [Memory] window. For example, to view the memory contents corresponding to `_main` in byte size:

- Select [Memory ...] from the [CPU] submenu of the [View] menu or click the [View Memory] toolbar button  to open the [Format] dialog box. Enter `_main` in the [Begin] edit box and `++f` in the [End] edit box, respectively, and select Byte in the [Format] combo box.

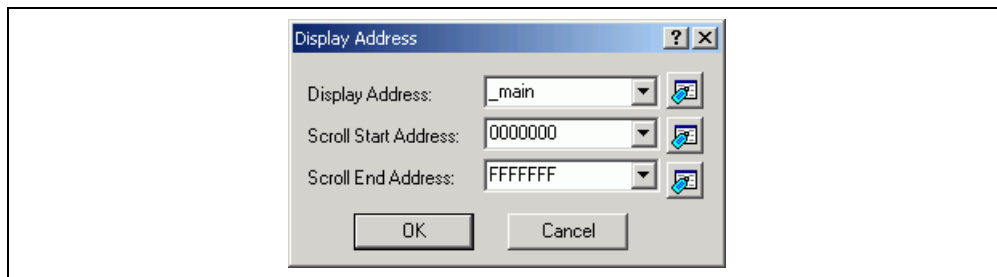

Figure 4.12 [Format] Dialog Box

- Click the [OK] button. The [Memory] window showing the selected area of memory is displayed.

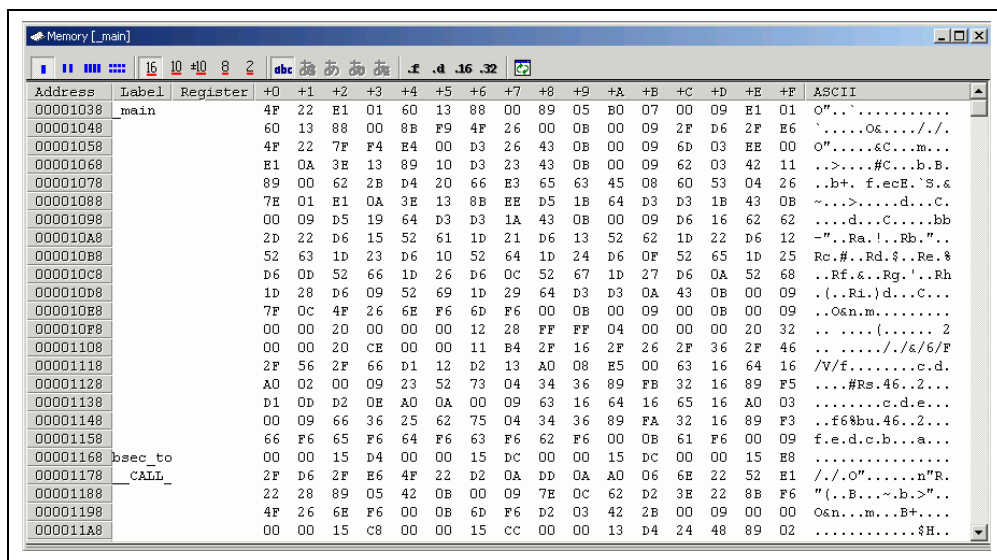

Figure 4.13 [Memory] Window

4.10 Watching Variables

As the user steps through a program, it is possible to watch that the values of variables used in the user program are changed. For example, set a watch on the long-type array `a` declared at the beginning of the program, by the following procedure:

- Click the left of displayed array `a` in the [Editor] window to place the cursor.
- Select [Instant Watch...] with the right-hand mouse button.

The following dialog box will be displayed.

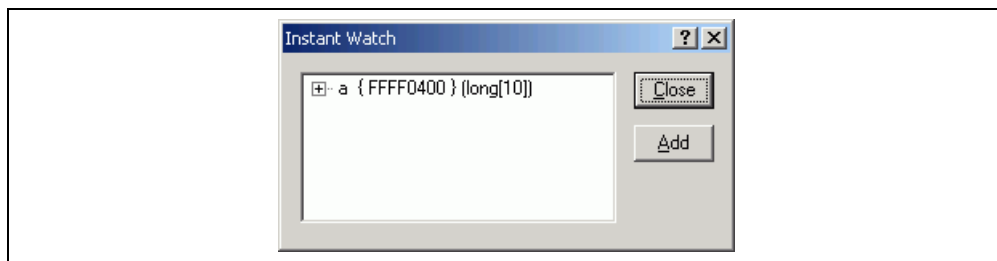

Figure 4.14 [Instant Watch] Dialog Box

- Click the [Add] button to add a variable to the [Watch] window.

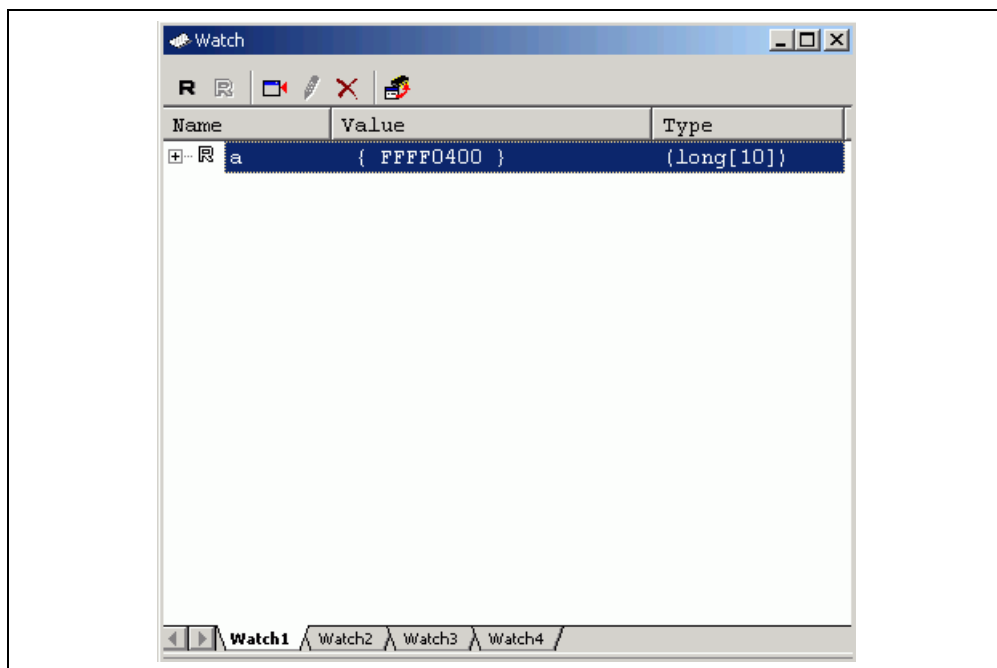

Figure 4.15 [Watch] Window (Displaying the Array)

The user can also add a variable to the [Watch] window by specifying its name.

- Click the [Watch] window with the right-hand mouse button and select [Add Watch...] from the popup menu.

The following dialog box will be displayed.

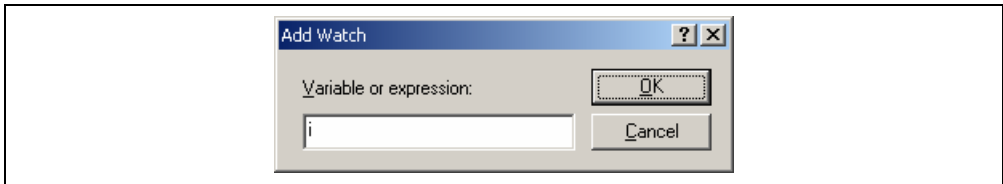

Figure 4.16 [Add Watch] Dialog Box

- Enter variable `i` to [Variable or expression] edit box and click the [OK] button.

The [Watch] window will now also show the int-type variable `i`.

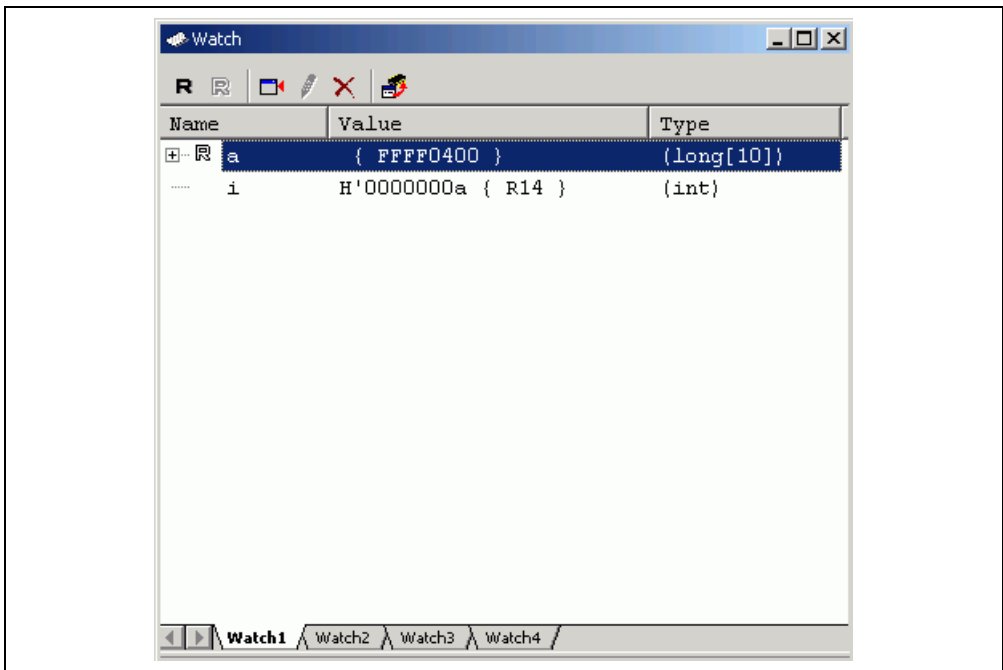

Figure 4.17 [Watch] Window (Displaying the Variable)

The user can click mark '+' at the left side of array a in the [Watch] window to watch all the elements.

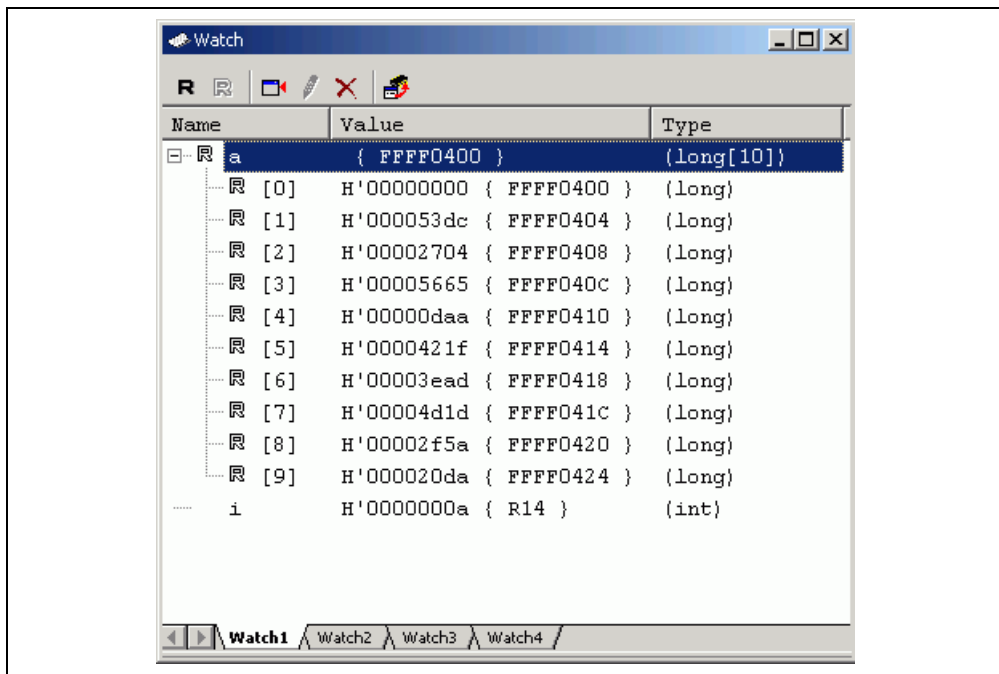

Figure 4.18 [Watch] Window (Displaying Array Elements)

4.11 Displaying Local Variables

The user can display local variables in a function by using the [Locals] window. For example, we will examine the local variables in the `tutorial` function, which declares local variables `j`, `i`, and `p_sam`.

- Select [Locals] from the [Symbol] submenu of the [View] menu. The [Locals] window is displayed.

The [Locals] window shows the local variables in the function currently pointed to by the program counter, along with their values. Note, however, that the [Locals] window is initially empty because local variables are yet to be declared.

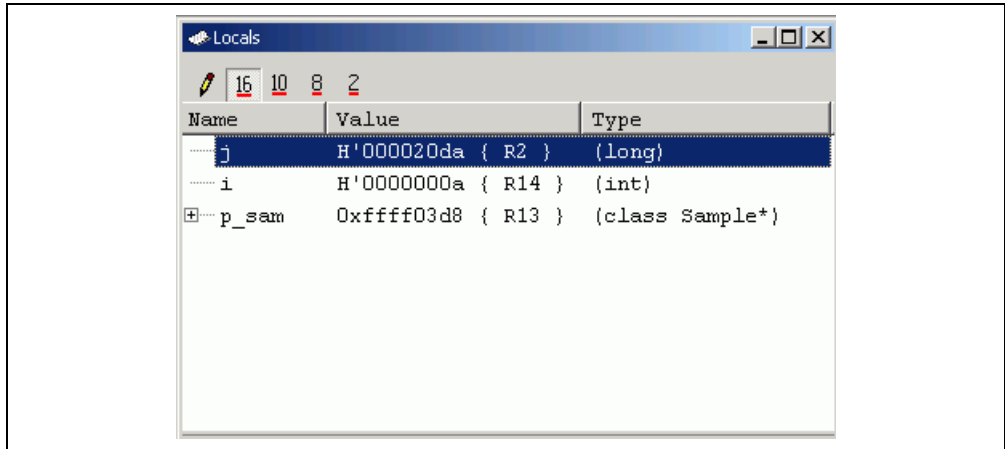

Figure 4.19 [Locals] Window

The user can click mark '+' at the left side of class instance `p_sam` in the [Locals] window to watch all the elements. View the elements of class instance `p_sam` before and after the execution of the `sort` function and check that the random data is sorted in the descending order.

4.12 Stepping Through a Program

The High-performance Embedded Workshop provides a range of step menu commands that allow efficient program debugging.

Table 4.2 Step Options

Menu Command	Description
Step In	Executes each statement, including statements within functions.
Step Over	Executes a function call in a single step.
Step Out	Steps out of a function, and stops at the statement following the statement in the program that called the function.
Step...	Steps the specified times repeatedly at a specified rate.

4.12.1 Executing the [Step In] Command

The [Step In] command steps into the called function and stops at the first statement of the called function.

- To step through the `sort` function, select [Step In] from the [Debug] menu, or click the [Step In] button on the toolbar.

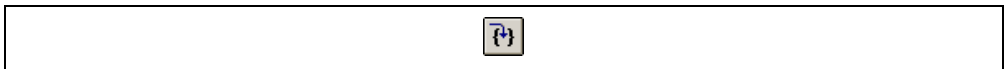

Figure 4.20 [Step In] Button

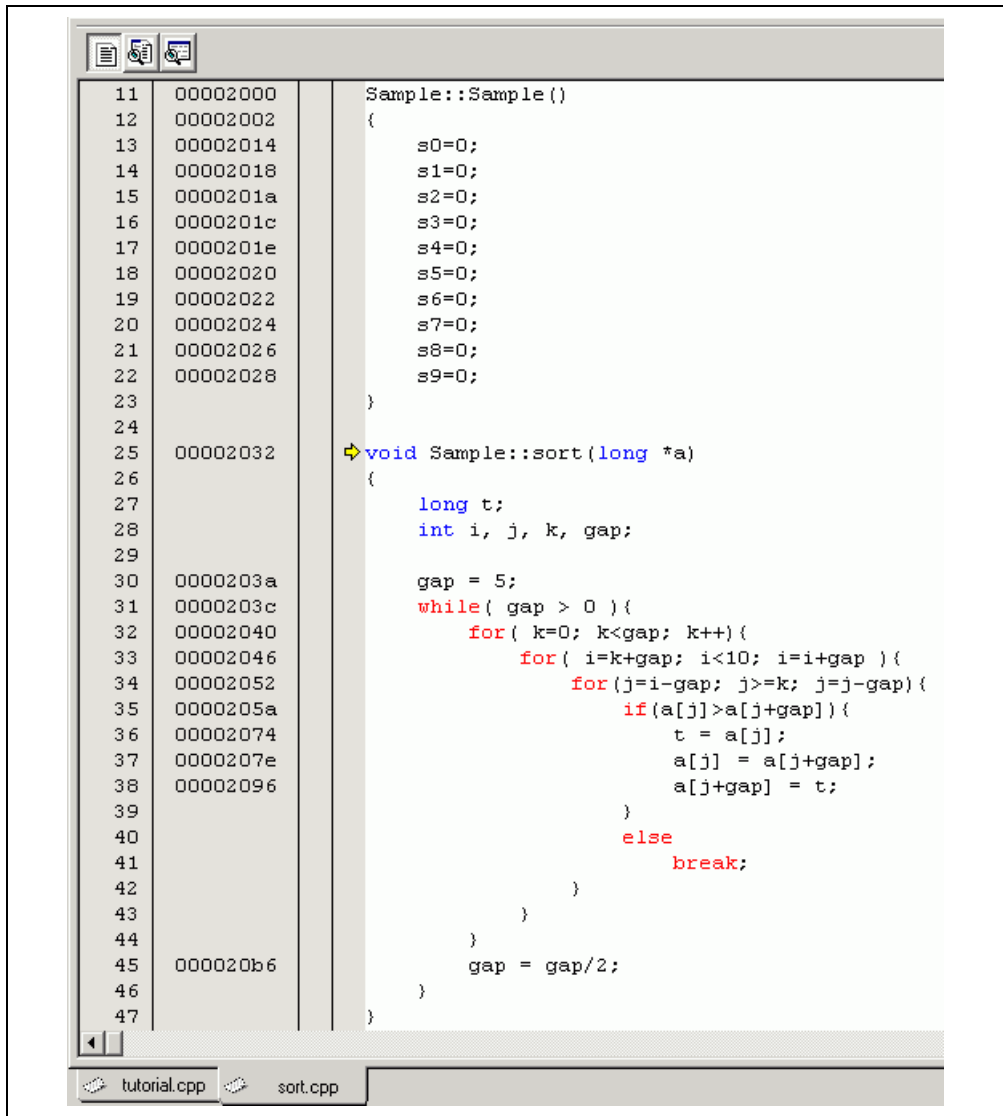

Figure 4.21 [Editor] Window (Step In)

- The highlighted line moves to the first statement of the `sort` function in the [Editor] window.

4.12.2 Executing the [Step Out] Command

The [Step Out] command steps out of the called function and stops at the next statement of the calling statement.

- To step out of the `sort` function, select [Step Out] from the [Debug] menu, or click the [Step Out] button in the toolbar.



Figure 4.22 [Step Out] Button

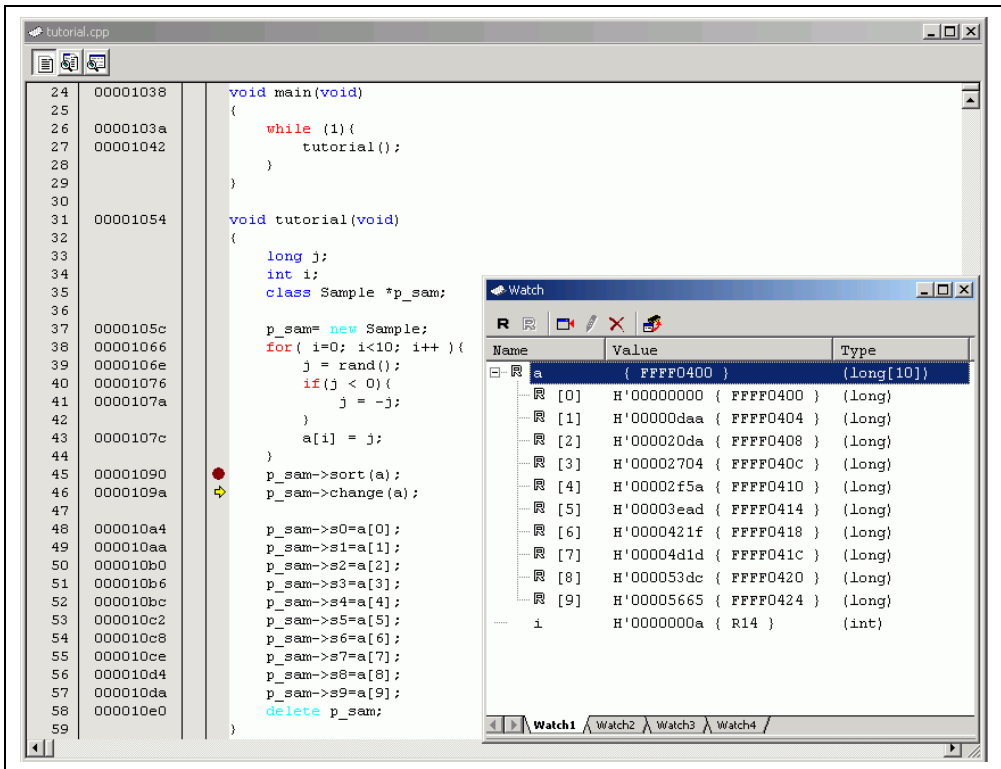

Figure 4.23 [High-performance Embedded Workshop] Window (Step Out)

The data of variable `a` displayed in the [Watch] window is sorted in the ascending order.

4.12.3 Executing the [Step Over] Command

The [Step Over] executes a function call in a single step and stops at the next statement of the main program.

- To step through all statements in the change function in a single step, select [Step Over] from the [Debug] menu, or click the [Step Over] button on the toolbar.



Figure 4.24 [Step Over] Button

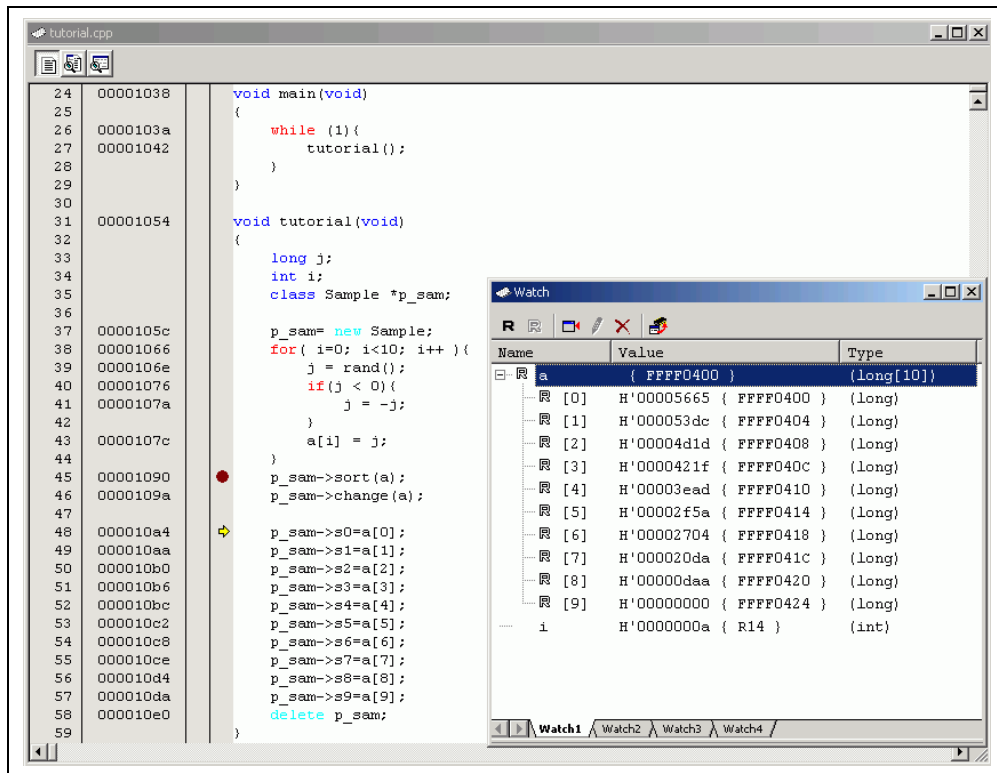

Figure 4.25 [High-performance Embedded Workshop] Window (Step Over)

The data of variable a displayed in the [Watch] window is sorted in the descending order.

4.13 Forced Breaking of Program Executions

The High-performance Embedded Workshop can force a break during the execution of a program.

- Cancel all the breakpoints.
- To execute the remaining sections of the tutorial function, select [Go] from the [Debug] menu or the [Go] button on the toolbar.



Figure 4.26 [Go] Button

- The program goes into an endless loop. To force a break during execution, select [Halt] from the [Debug] menu or the [Halt] button on the toolbar.



Figure 4.27 [Halt] Button

4.14 Resetting the Target MCU

Resetting the target MCU initializes the on-chip I/O registers and makes the program counter jump to the address set in the reset vector.

- To reset the target MCU, select [Reset CPU] from the [Debug] menu or the [Reset CPU] button on the toolbar.



Figure 4.28 [Reset CPU] Button

- To execute the user program immediately after a reset, select [Reset Go] from the [Debug] menu or the [Reset Go] button on the toolbar.



Figure 4.29 [Reset Go] Button

Note: This tutorial program is executable from the reset vector.

4.15 Break Function

The emulator provides break functions by software breaks, on-chip breaks, and on-emulator breaks. Software breakpoints, on-chip breakpoints, and on-emulator breakpoints can be set in the High-performance Embedded Workshop's [Event] window.

An overview and setting of the break function are described below.

4.15.1 Software Break Function

The emulator can set up to 255 software breakpoints.

- Select [Eventpoints] from the [Code] submenu of the [View] menu or click the [Eventpoints] toolbar button (). The [Event] window is displayed.
- Select the [Software] sheet.

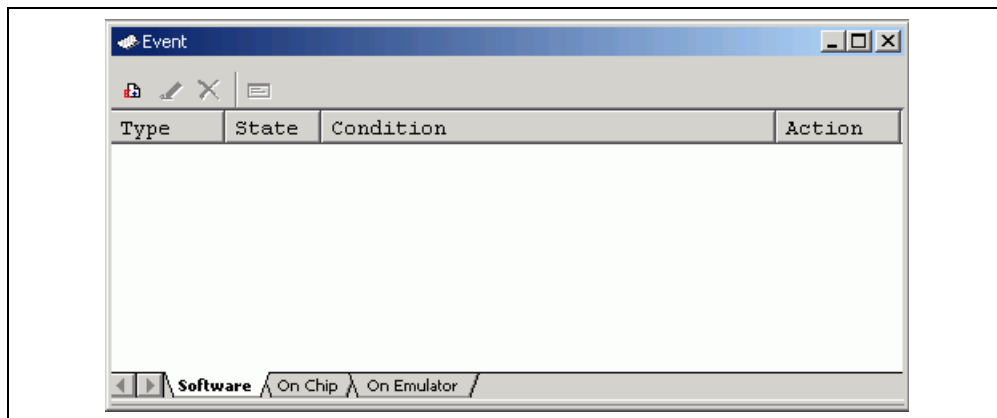

Figure 4.30 [Event] Window (Before Setting a Software Breakpoint)

- Click the [Event] window with the right-hand mouse button and select [Add...] from the popup menu.
- The [Breakpoint Properties] dialog box ([Software Break] page) is displayed.

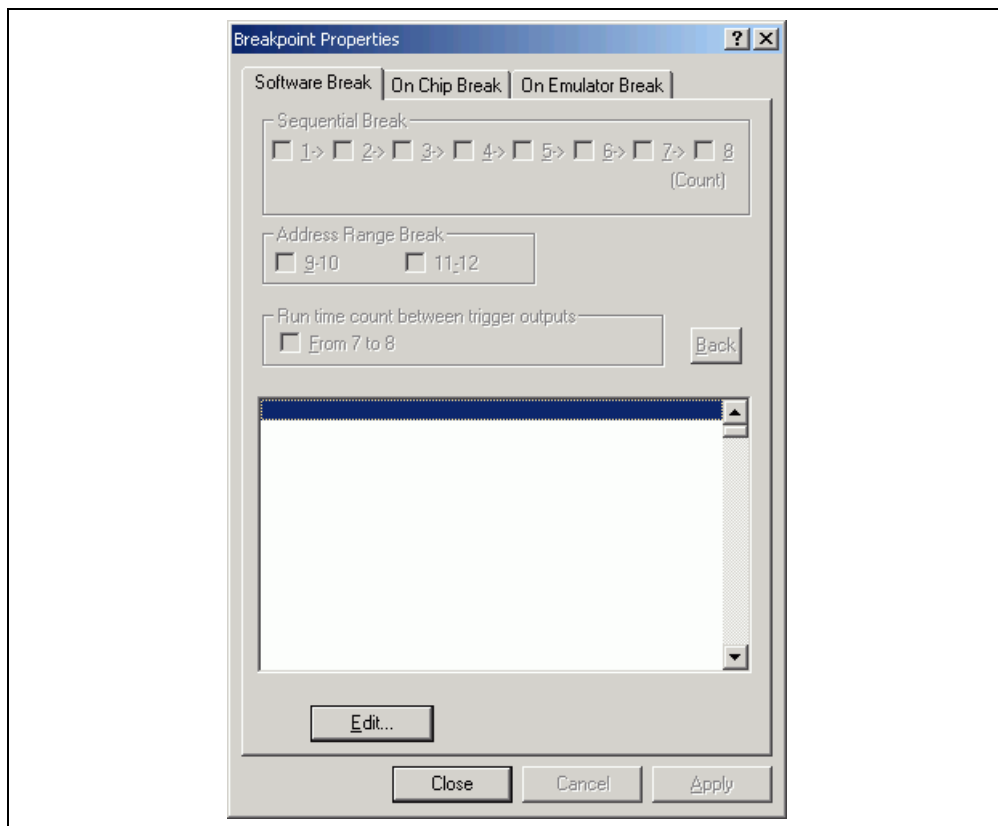

Figure 4.31 [Breakpoint Properties] Dialog Box

- Click the [Edit...] button to display the [Software Break] dialog box.

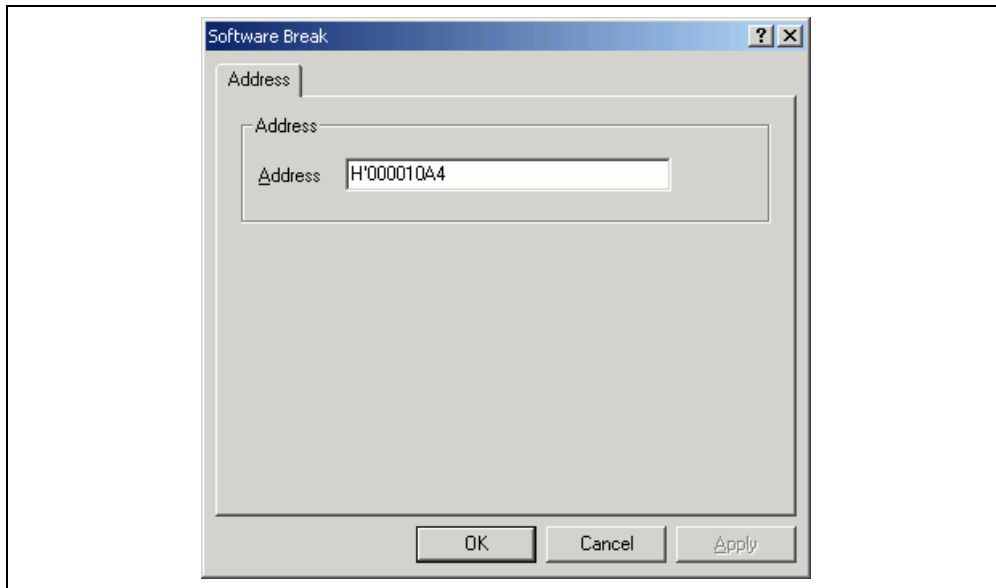

Figure 4.32 [Software Break] Dialog Box

- Use the [Editor] window to refer to the address on the line that has 'p_sam->s0=a[0];' within the `tutorial` function and enter this address in the [Address] edit box. In this example, enter **H'000010A4**.

Note: This dialog box differs depending on the product. For the items of each product, refer to section 3, Debugging, or the online help.

- Click the [OK] button. Then click the [Close] button on the [Breakpoint Properties] dialog box.

The software breakpoint that has been set is displayed in the [Event] window.

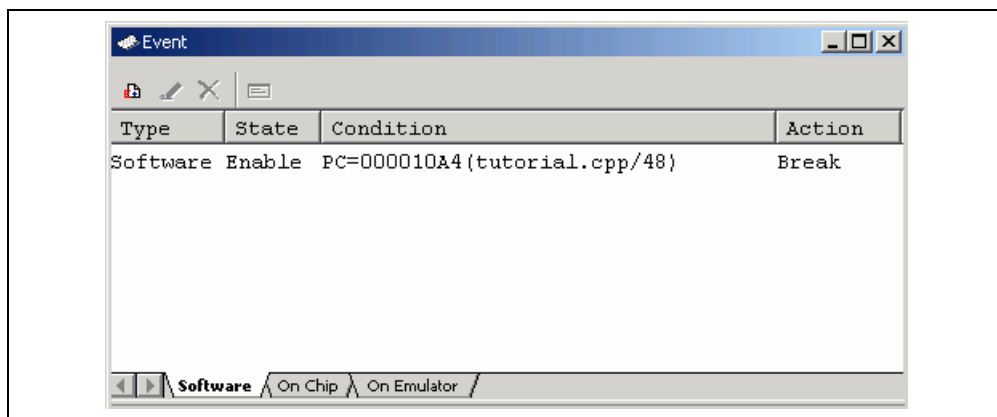

Figure 4.33 [Event] Window (Software Breakpoint Setting)

Note: The items that can be displayed in this window differ depending on the product. For the items that can be displayed, refer to section 3, Debugging, or the online help.

- Close the [Event] window.
- To stop the tutorial program at the breakpoint, select [Reset Go] from the [Debug] menu.

The program runs until it stops at the breakpoint that has been set.

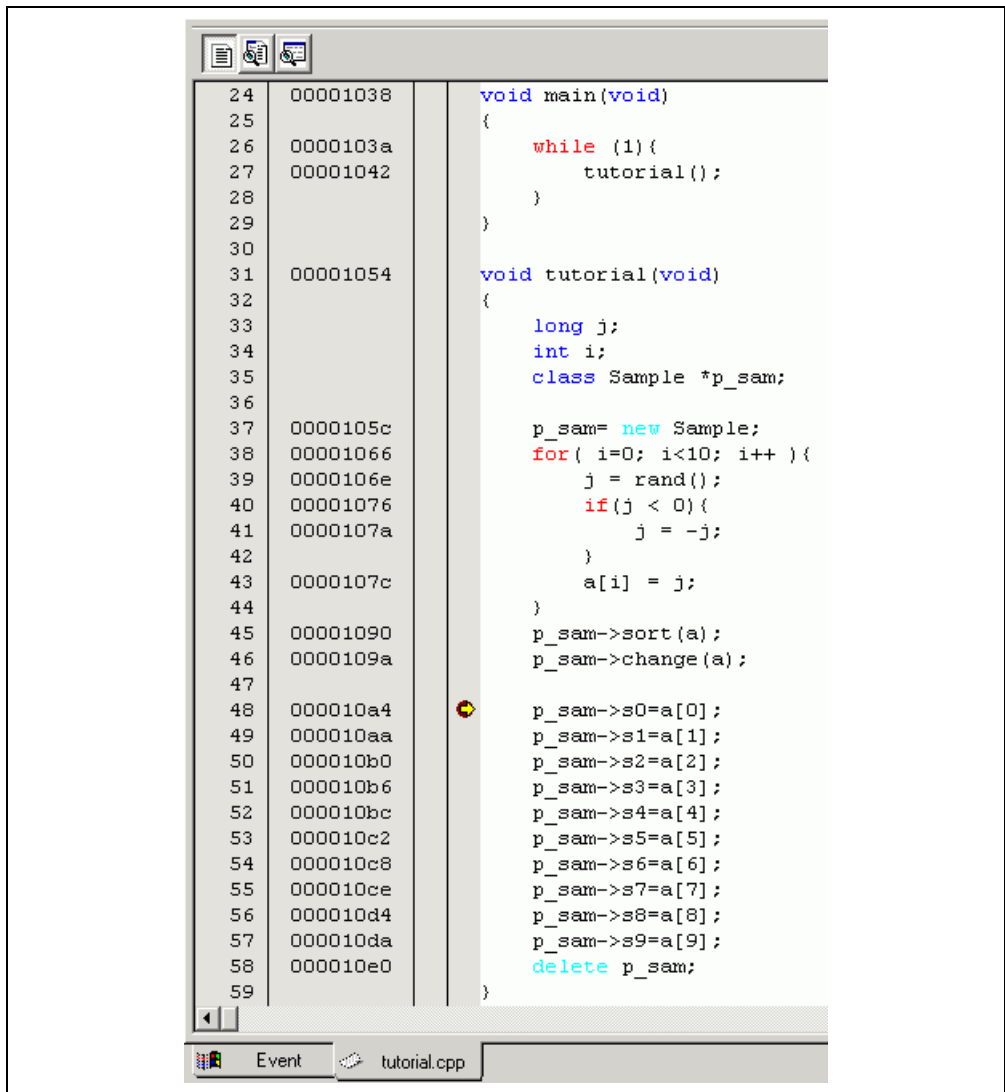

Figure 4.34 [Editor] Window at Execution Stop (Software Break)

The [Status] window displays the following contents:

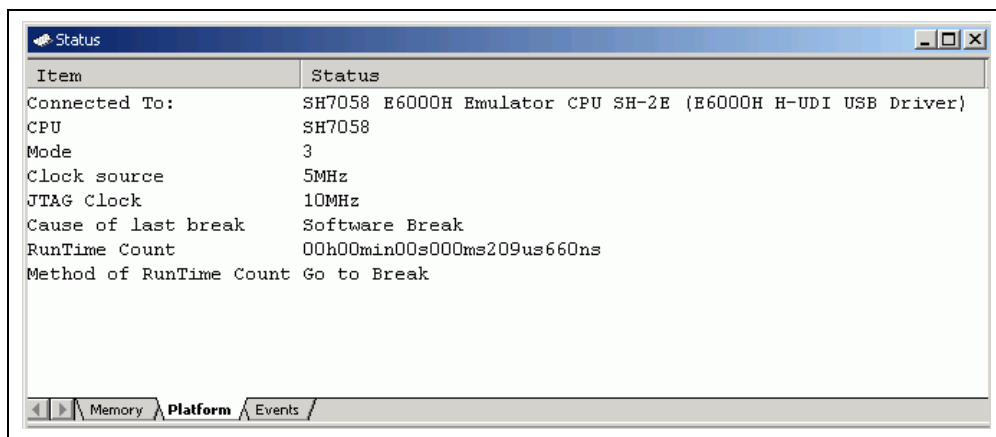



Figure 4.35 Displayed Contents of the [Status] Window (Software Break)

Note: The items that can be displayed in this window differ depending on the product. For the items that can be displayed, refer to section 3, Debugging, or the online help.

4.15.2 On-Chip Break Function

Setting of an on-chip breakpoint on channel 8 such that a break is triggered when the break condition has been satisfied five times is explained as an example of the use of on-chip breakpoints.

Note: The channels on which the satisfaction count can be specified differ depending on the product. For details on each product, refer to section 3, Debugging, or the online help.

- Select [Eventpoints] from the [Code] submenu of the [View] menu or click the [Eventpoints] toolbar button () . The [Event] window is displayed.
- The software breakpoint that has been previously set must be deleted. Click the [Software] sheet of the [Event] window with the right-hand mouse button and select [Delete All] from the popup menu to delete all the software breakpoints that have been set.
- Click the [On Chip] tab of the [Event] window.
- Click the [Event] window with the right-hand mouse button and select [Add...] from the popup menu.
- The [Breakpoint Properties] dialog box ([On Chip Break] page) is displayed.

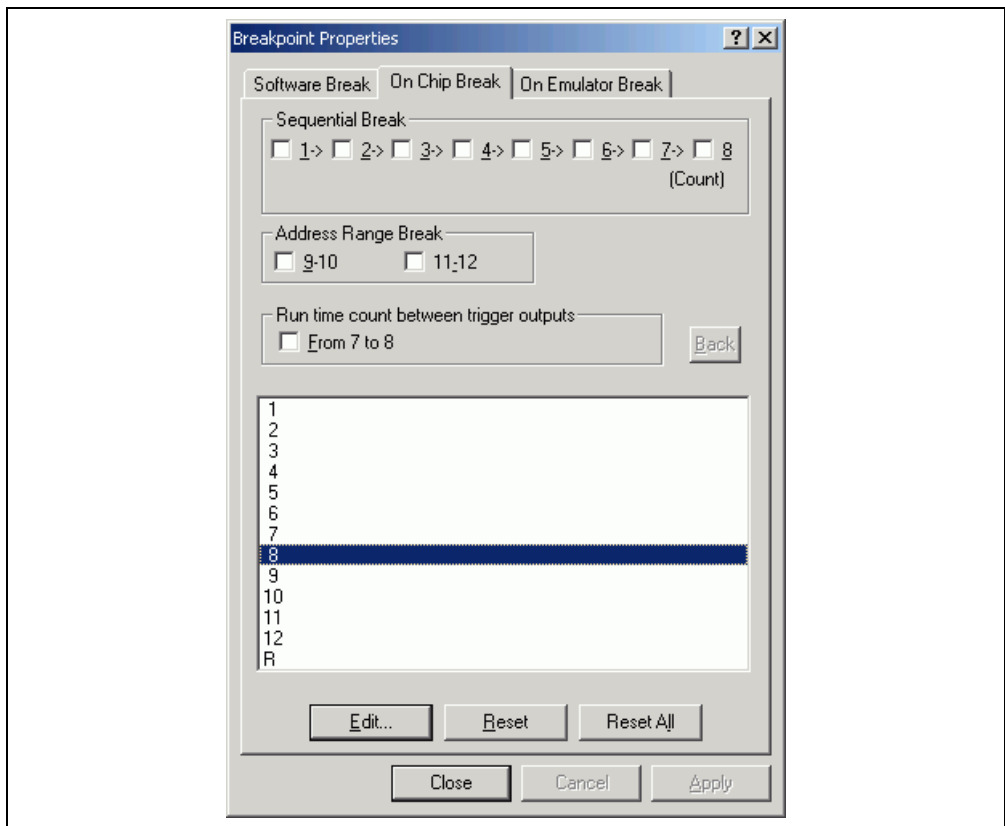

Figure 4.36 [Breakpoint Properties] Dialog Box ([On Chip Break] Page)

- Select [8] in the list box and click the [Edit...] button. The [On Chip Break Channel 8] dialog box is displayed.

- Make the following settings in the group boxes on the [Address] page:
 Uncheck the [Don't Care] checkbox.
 Then use the [Editor] window to refer to the address on the line that has 'a[i]=j;' within the tutorial function and enter this address in the [Address] edit box. In this example, enter **H'0000107C**.
- Make the following settings in the boxes on the [Count] page:
 Uncheck the [Don't Care] checkbox.
 Enter **D'5** in the [Count] edit box.

Note: The content of this dialog box differs depending on the product. For details on each product, refer to section 3, Debugging, or the online help.

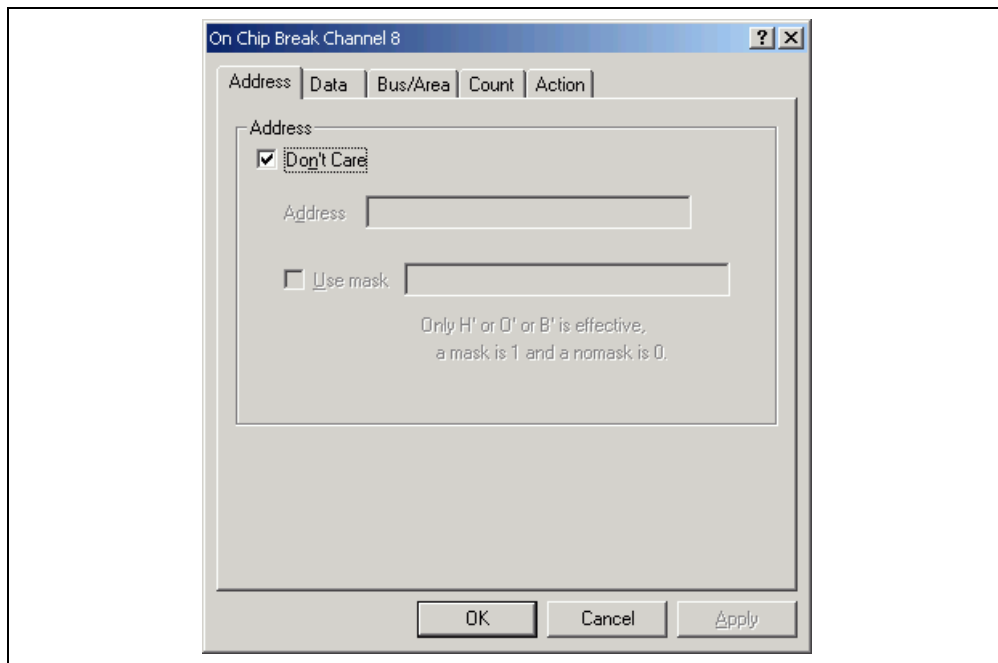

Figure 4.37 [On Chip Break Channel 8] Dialog Box

- Click the [OK] button. Then click the [Close] button on the [Breakpoint Properties] dialog box.

The on-chip breakpoint that has been set is displayed in the [Event] window.

Note: The items that can be displayed in this window differ depending on the product. For the items that can be displayed, refer to section 3, Debugging, or the online help.

Close the [Event] window. Then select [Reset Go] from the [Debug] menu to stop the tutorial program at on-chip breakpoints. The program runs and then stops at the breakpoint that has been set. The cause of a break can be checked in [Cause of last break] of the [Status] window.

Refer to the [Watch] window for the value of variable *i*. The value is 4, indicating that the break occurred after the condition had been satisfied five times.

Then delete the on-chip breakpoint. Clicking the right-hand mouse button on the [Event] window displays a popup menu. Select [Delete All] from this menu to delete all the on-chip breakpoints.

4.16 Trace Functions

The trace functions of the emulator use the realtime trace buffer, which can store the information of up to 128-k bus cycles. The content of this buffer, which is constantly updated during execution, is displayed in the [Trace] window.

Select [Trace] from the [Code] submenu of the [View] menu or click the [Trace] toolbar button () to display the [Trace] window.

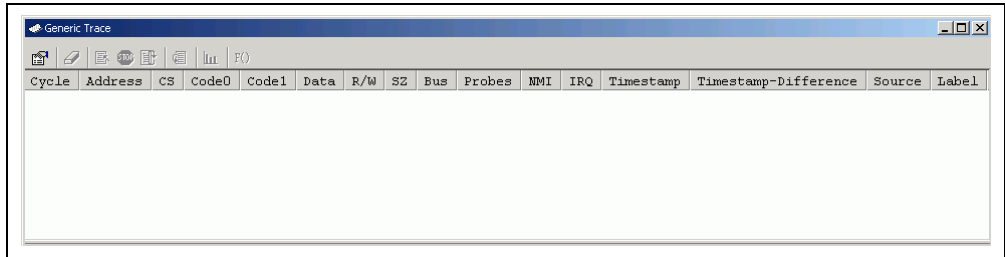

Figure 4.38 [Trace] Window

When trace information is displayed in the [Trace] window, clicking the right-hand mouse button on the [Trace] window displays a popup menu. Select [Clear] from this menu to clear the trace information.

The following sections give an overview of the trace functions and the settings.

4.16.1 Displaying Trace Information by the Free Trace Function

The free trace function allows continuous acquisition of trace information from the start of user program execution to the occurrence of a break.

- (1) All break conditions must be deleted. Clicking the right-hand mouse button on the [Trace] window displays a popup menu. Select [Acquisition...] from this menu to display the [Trace Acquisition Properties] dialog box. Ensure that [Free Trace] is checked and then click the [Close] button.

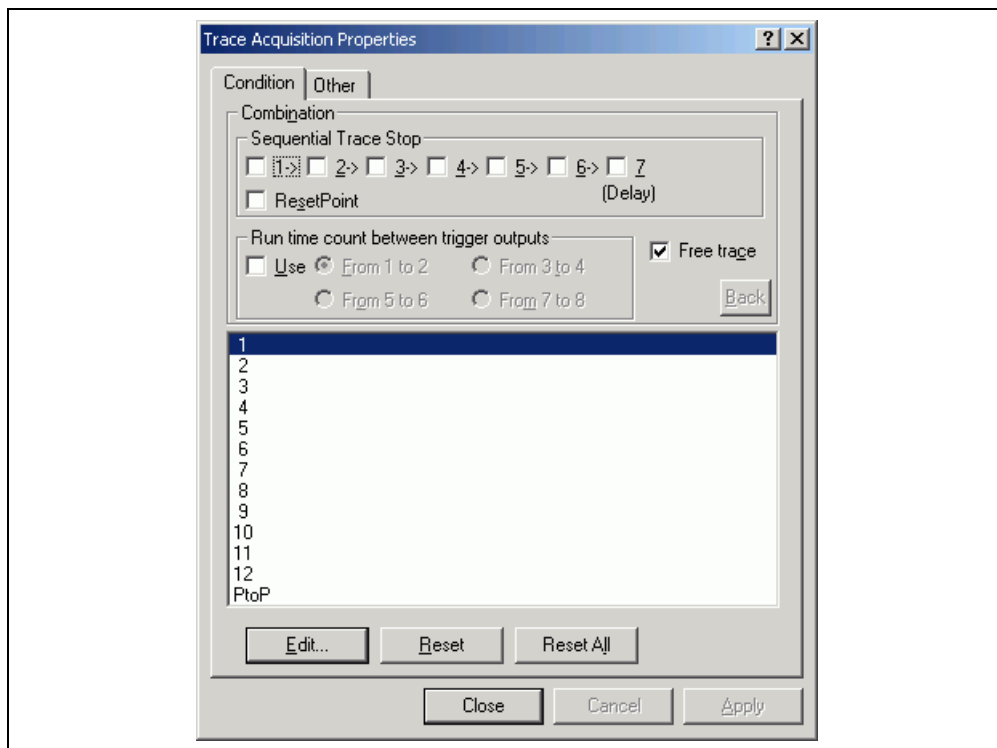

Figure 4.39 [Trace Acquisition Properties] Dialog Box (Free Trace)

- (2) Set a software breakpoint at the address on the line that has 'p_sam->s0=a[0];' within the tutorial function (refer to section 4.15.1, Software Break Function).
- (3) Select [Reset Go] from the [Debug] menu. Execution stops when the break condition is satisfied, and the [Trace] window then displays the trace information.

Cycle	Address	CS	Code0	Code1	Data	R/W	SZ	Bus	Probes	MMI	IRQ	Timestamp
-00010	ffffbfa4				00000000	RD	L	CPU	1111		1	0000h0.
-00009	00002120	MOV	R4, R0	MOV.L	R1, @(...	60430516	IF	CPU	1111		1	0000h0.
-00008	00002124	ADD	#H'01, R2	MOV	#H'0A, R7	7201e70a	IF	CPU	1111		1	0000h0.
-00007	ffff0424				00000000	WR	L	CPU	1111		1	0000h0.
-00006	00002128	CMP/GE	R7, R2	BF	@H'21...	32738bec	IF	CPU	1111		1	0000h0.
-00005	0000212c	ADD	#H'2c, R15	MOV.L	@R15+, R9	7f2c69f6	IF	CPU	1111		1	0000h0.
-00004	00002130	RTS		MOP	000b0009	IF		CPU	1111		1	0000h0.
-00003	ffffbfd0				00000000	RD	L	CPU	1111		1	0000h0.
-00002	000010a4	.DATA.W	H'0000		00006262	IF		CPU	1111		1	0000h0.
-00001	000010a8				2d22d615	IF		CPU	1111		1	0000h0.
+00000	-----								1111		1	0000h0.

Figure 4.40 [Trace] Window (Free Trace)

4.16.2 Displaying Trace Information by the Trace Stop Function

While the trace stop function is in use, acquisition of trace information stops when a specified condition is satisfied. The user can check the program flow by the trace information without breaking the user program execution.

- (1) Delete all the break conditions that have been set. Uncheck [Free Trace] on the [Condition] page of the [Trace Acquisition Properties] dialog box (otherwise, the free trace mode will be selected).
- (2) Select [1] from the list box on the [Condition] page of the [Trace Acquisition Properties] dialog box and then click [Edit...]. The [Trace Acquisition Condition Channel 1] dialog box is displayed. Select the [Trace Stop] radio button in the [After Condition Match] group box on the [Action] page.

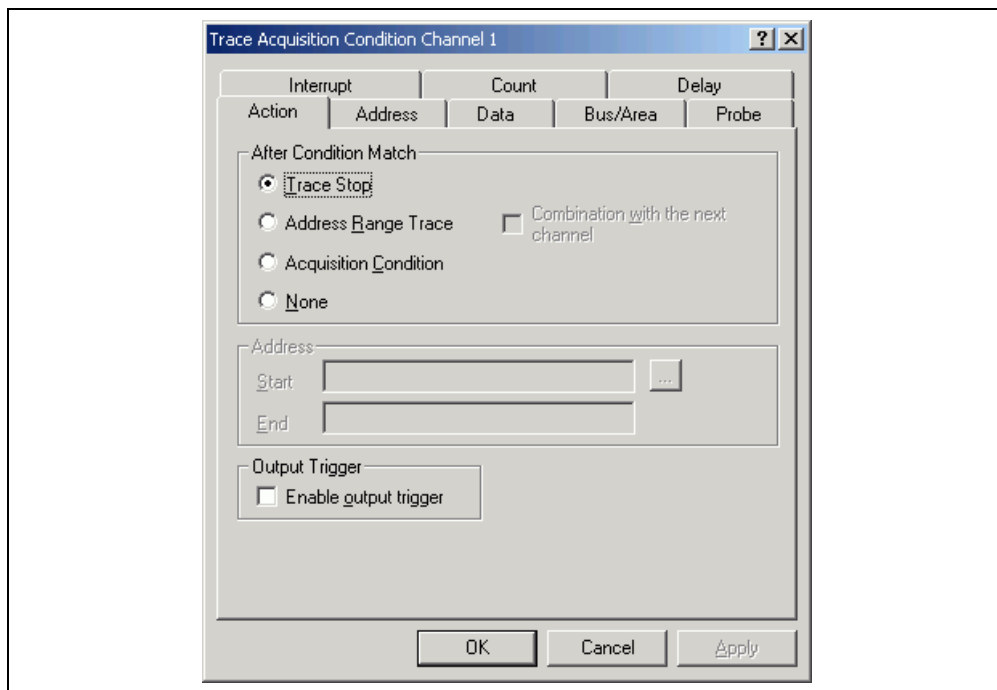

Figure 4.41 [Trace Acquisition Condition Channel 1] Dialog Box (Trace Stop)

- An address must be set as the condition. Uncheck [Don't Care] on the [Address] page of the [Trace Acquisition Condition Channel 1] dialog box. Then use the [Editor] window to refer to the address on the line that includes 'a[i]=j;' within the tutorial function and enter this address in the [Start] edit box. In this example, enter `H'0000107C`. This completes the setting of the address. Click the [OK] button to close the [Trace Acquisition Condition Channel 1] dialog box.

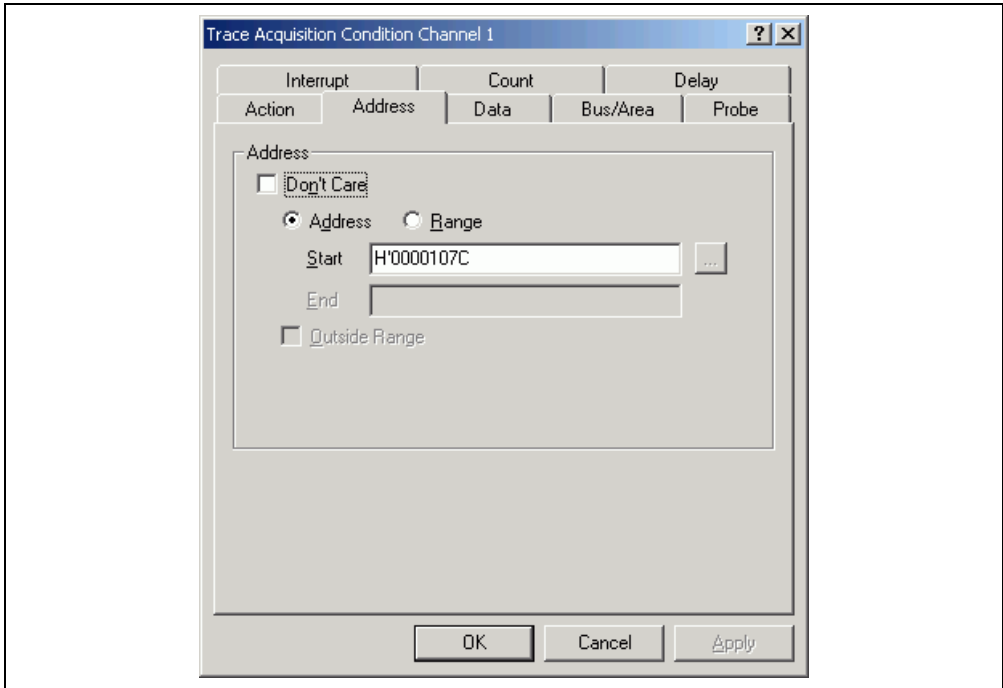

Figure 4.42 [Trace Acquisition Condition Channel 1] Dialog Box ([Address] Page)

- (4) Items that have been set are displayed in the list box on the [Condition] page of the [Trace Acquisition Properties] dialog box. Click the [Close] button on this dialog box.

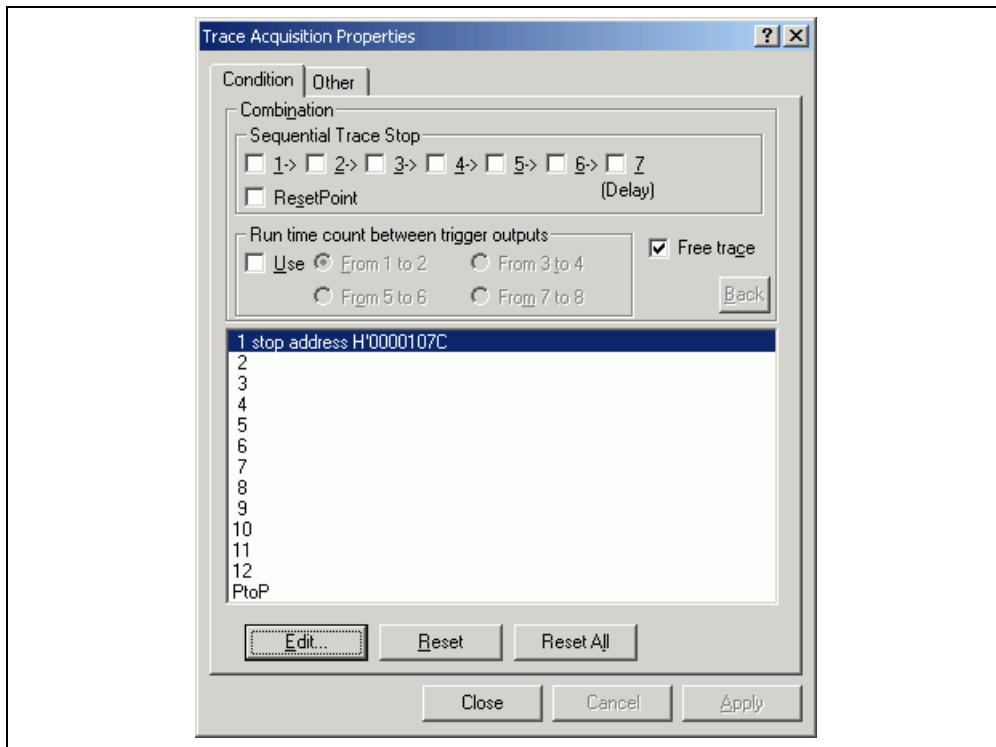

Figure 4.43 [Trace Acquisition Properties] Dialog Box (Trace Stop)

- (5) Select [Reset Go] from the [Debug] menu. The trace condition is satisfied, and the [Trace] window then displays the following contents.

Cycle	Address	CS	Code0	Code1	Data	R/W	SZ	Bus	Probes	NMI	IRQ	Timestamp
-00010	00001074		MOV R0, R2	CMP/PZ R2	62034211	IF		CPU	1111			0000h0.
-00009	ffffbfd0				00000000	RD	L	CPU	1111			0000h0.
-00008	00001078		BT @H'107C:8		8900622b	IF		CPU	1111			0000h0.
-00007	0000107c				d42066e3	IF		CPU	1111			0000h0.
-00006	0000107c		MOV.L @(H'0080:8, PC), R4	MOV R14, R6	d42066e3	IF		CPU	1111			0000h0.
-00005	00001080		MOV R6, R5	SHLL2 R5	65634508	IF		CPU	1111			0000h0.
-00004	00001100				ffff0400	RD	L	CPU	1111			0000h0.
-00003	00001084		MOV R5, R0	MOV.L R2, @(...	60530426	IF		CPU	1111			0000h0.
-00002	00001088		ADD #H'01, R14	MOV #H'0A, R1	7e01e10a	IF		CPU	1111			0000h0.
-00001	ffff0400				00000000	WR	L	CPU	1111			0000h0.
+00000	0000108c				3e138bee	IF		CPU	1111			0000h0.

Figure 4.44 [Trace] Window (Trace Stop)

4.16.3 Displaying Trace Information by the Conditional Trace Function

The conditional trace function only acquires trace information at the address where a specified condition has been satisfied. This is useful for analyzing a program focused on reading from or writing to a specific address (e.g. a global variable or memory mapped I/O).

- (1) If the user program is running, select [Halt Program] from the [Debug] menu to halt the program.
- (2) Delete all the break conditions that have been set. Uncheck [Free Trace] on the [Condition] page of the [Trace Acquisition Properties] dialog box (otherwise, the free trace mode will be selected).
- (3) Select [1] from the list box on the [Condition] page of the [Trace Acquisition Properties] dialog box and then click [Edit...]. The [Trace Acquisition Condition Channel 1] dialog box is displayed. Select the [Acquisition Condition] radio button in the [After Condition Match] group box on the [Action] page.
- (4) An address must be set as the condition. Uncheck [Don't Care] on the [Address] page of the [Trace Acquisition Condition Channel 1] dialog box. Then use the [Watch] window to refer to the address on the line that includes 'a[0]' and enter this address in the [Start] edit box. In this example, enter **H'FFFF0400**. This completes the setting of an address. Click the [OK] button to close the [Trace Acquisition Condition Channel 1] dialog box.
- (5) Items that have been set are displayed in the list box on the [Condition] page of the [Trace Acquisition Properties] dialog box. Click the [Close] button on this dialog box.
- (6) Set a software breakpoint at the address on the line that has 'delete p_sam;' within the tutorial function (**H'000010E0** in this example) (for details, refer to section 4.15.1, Software Break Function).
- (7) Select [Reset Go] from the [Debug] menu. Execution stops when the break condition is satisfied, and the [Trace] window then displays the following contents.

Cycle	Address	CS	Code0	Code1	Data	R/W	SZ	Bus	Probes	NMI	IRQ	TimeSt
-00010	-----								1111		1	0000h0
-00009	ffff0400				00000000	RD	L	CPU	1111		1	0000h0
-00008	-----								1111		1	0000h0
-00007	ffff0400				00000000	RD	L	CPU	1111		1	0000h0
-00006	-----								1111		1	0000h0
-00005	ffff0400				00000000	RD	L	CPU	1111		1	0000h0
-00004	-----								1111		1	0000h0
-00003	-----								1111		1	0000h0
-00002	ffff0400				00005665	WR	L	CPU	1111		1	0000h0
-00001	ffff0400				00005665	RD	L	CPU	1111		1	0000h0
+00000	-----								1111		1	0000h0

Figure 4.45 [Trace] Window (Conditional Trace)

4.16.4 Statistics

The number of times the on-chip RAM has been written to can be included in the acquired trace information.

- (1) Delete all the break conditions that have been set. Click [Reset All] on the [Condition] page of the [Trace Acquisition Properties] dialog box to cancel trace conditions. Check [Free Trace] on the [Condition] page of the [Trace Acquisition Properties] dialog box.
- (2) Make the setting so that a break occurs at the address on the line that has 'p_sam->s0=a[0];' within the tutorial function (**H'000010A4** in this example) (for details on, refer to section 4.15.1, Software Break Function).
- (3) Select [Reset Go] from the [Debug] menu. Execution stops when the break condition is satisfied, and the [Trace] window then displays the trace information.
- (4) Select [Statistic...] from the popup menu that is displayed when you click the right-hand mouse button on the [Trace] window. A message box appears, indicating that the trace data is being loaded, and the [Statistic] dialog box will be displayed.

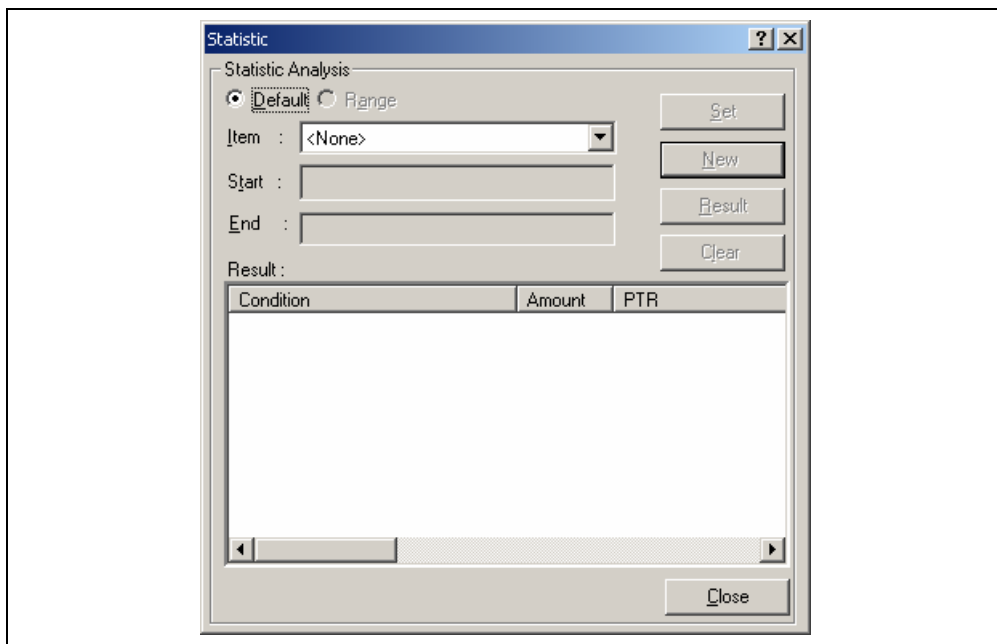

Figure 4.46 [Statistic] Dialog Box

- (5) Select [R/W] in the [Item] combo box and enter **WR** in the [Start] edit box. Then, click the [New] button. "R/W=WR" will be displayed in the [Condition] column of the [Result] list box.

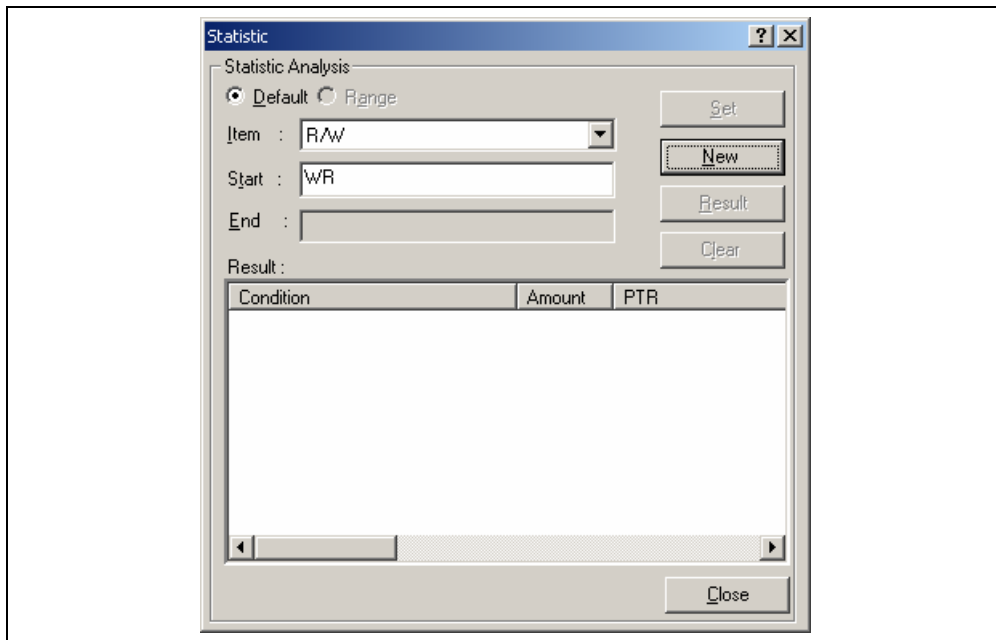

Figure 4.47 [Statistic] Dialog Box (New Condition)

- (6) Then, select [SZ] from the [Item] combo box and enter **L** in the [Start] edit box. Then, click the [Add] button; the new condition is now added to the "R/W=WR" display in the [Condition] column of the [Result] list box, so that it now shows "R/W=WR & SZ=L". This completes the setting of the conditions.

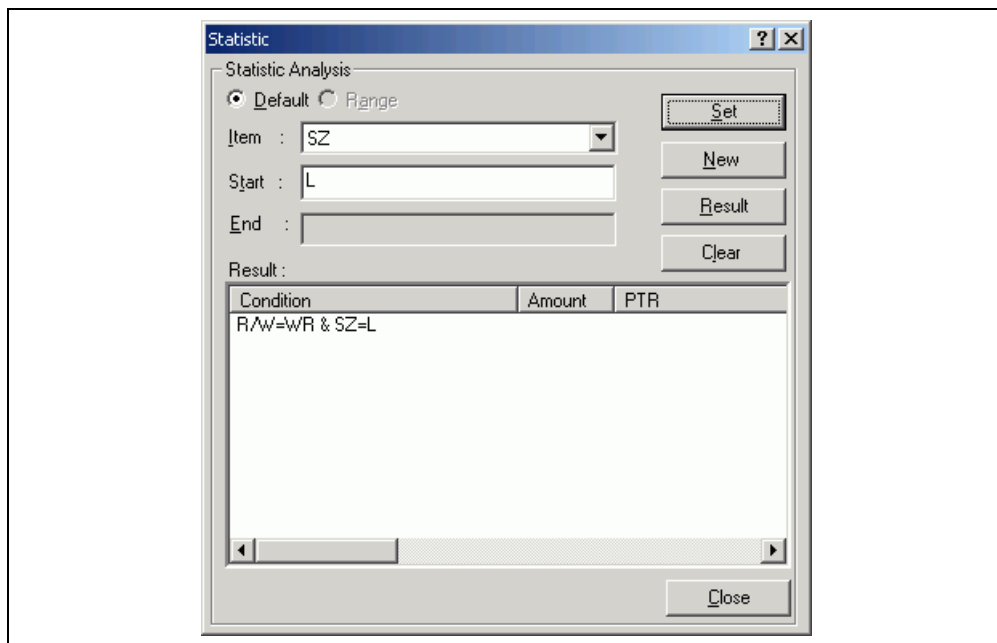

Figure 4.48 [Statistic] Dialog Box (Condition Added)

- (7) To start statistical analysis of the specified condition, press the [Result] button. The number of write operations that satisfies the conditions and the PTR values will be displayed.

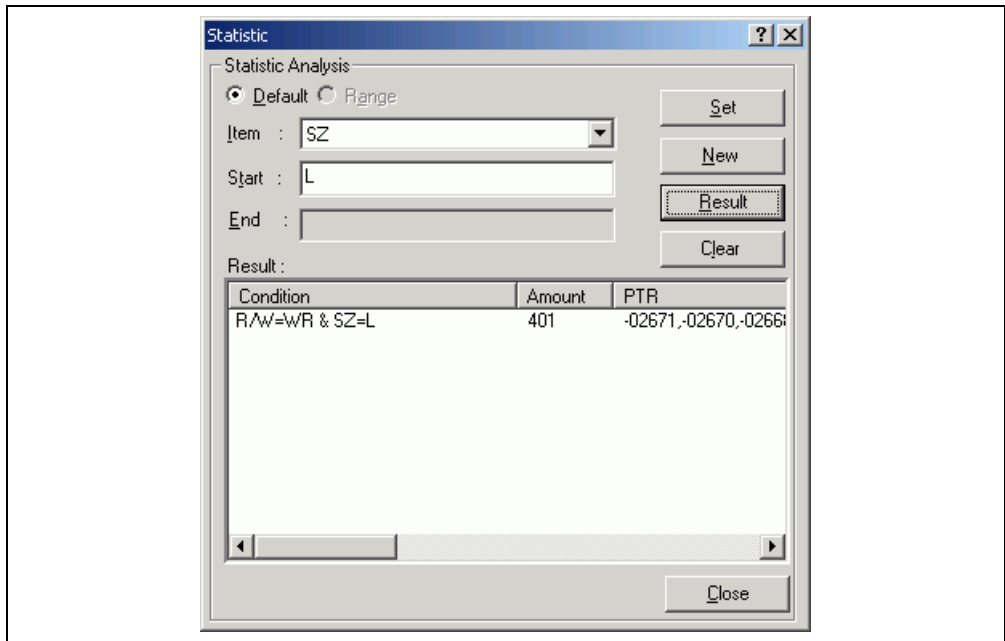

Figure 4.49 [Statistic] Dialog Box (Result of Analysis)

- (8) Click the [Close] button to close the [Statistic] dialog box.
- (9) Delete the event points that have been set and clear the trace information. Clicking the right-hand mouse button on the [Event] window displays a popup menu. Select [Delete All] from this menu to delete all the event points that have been set. Clicking the right-hand mouse button on the [Trace] window displays a further popup menu. Select [Clear] from this menu to clear the trace information.

4.16.5 Function Calls

This mechanism is only used to collect trace information on the function calls.

- (1) Make the setting so that a break occurs at the address on the line that has 'p_sam->s0=a[0];' within the tutorial function (**H'000010A4** in this example) (for details, refer to section 4.15.1, Software Break Function).
- (2) Select [Reset Go] from the [Debug] menu. Execution stops when the break condition is satisfied, and the [Trace] window then displays the trace information.
- (3) Select [Function Call...] from the popup menu displayed by clicking the right-hand mouse button on the [Trace] window. The [Function Call Display] dialog box will be displayed.

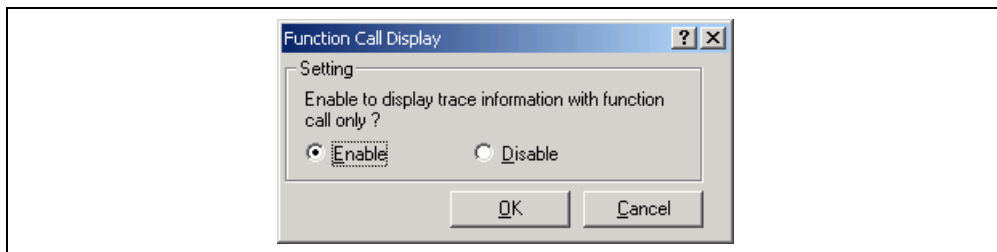

Figure 4.50 [Function Call Display] Dialog Box

- (4) Click the [Enable] radio button and then the [OK] button. Only the information on function calls is now displayed in the [Trace] window.

Cycle	Address	CS	Data	R/W	SZ	Bus	Probes	NMI	IRQ	Source	Label
-02679	00000a00		d20ce610	IF		CPU	1111		1	set_vbr((void *)((char *)...)	_PowerON_Reset_PC
-01475	00001038		4f22e101	IF		CPU	1111		1	void main(void)	_main
-01470	00001054		2fd62fe6	IF		CPU	1111		1	void tutorial(void)	tutorial()
-01462	00002000		4f222448	IF		CPU	1111		1	Sample::Sample()	Sample::Sample()
-01389	00001000		7ffcd60b	IF		CPU	1111		1	char *sbrk(unsigned long size...)	_sbrk
-00974	00002032		00092fc6	IF		CPU	1111		1	void Sample::sort(long *a)	Sample::sort(Long *)
-00268	000020ce		00092f96	IF		CPU	1111		1	void Sample::change(long *a)	Sample::change(Long *)

Figure 4.51 [Trace] Window (Function Calls)

- (5) To return the display in the [Trace] window to its previous state, follow the procedure in (3) to display the [Function Call Display] dialog box. Click the [Disable] button and then the [OK] button.
- (6) Delete the event points that have been set and clear the trace information. Clicking the right-hand mouse button on the [Event] window displays a popup menu. Select [Delete All] from this menu to delete all the event points that have been set. Clicking the right-hand mouse button on the [Trace] window displays a further popup menu. Select [Clear] from this menu to clear the trace information.

4.17 Stack Trace Function

The emulator uses the information on the stack to display the function call history.

- Notes: 1. This function can be used only when the load module that has the Dwarf2-type debugging information is loaded. Such load modules are supported in H8S, H8/300 C/C++ compiler V4.0 or later.
2. For details on the stack trace function, refer to the online help.
- Double-click the [S/W Breakpoints] column in the `sort` function and set a software breakpoint.

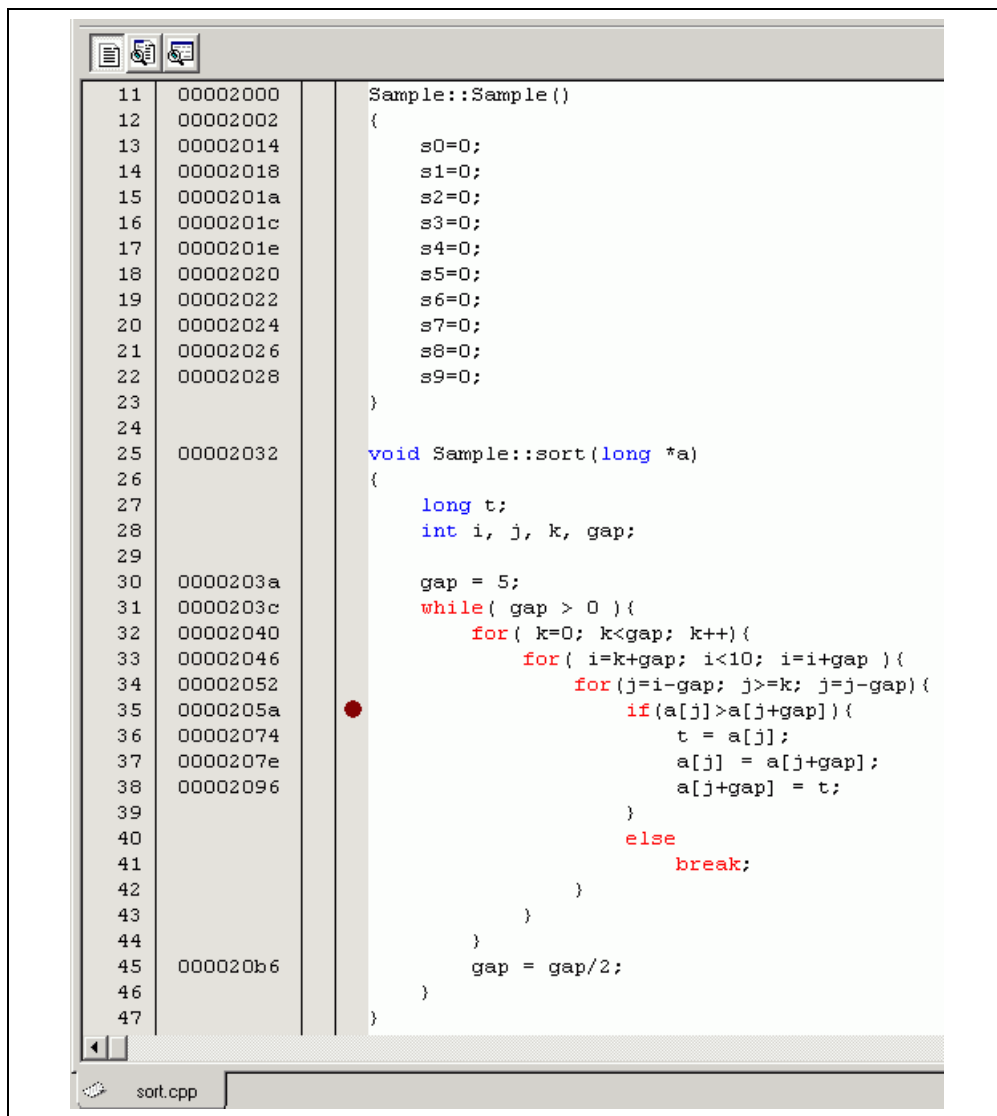

Figure 4.52 [Editor] Window (Software Breakpoint Setting)

- Select [Reset Go] from the [Debug] menu.
- After the break in program execution, select [Stack Trace] from the [Code] submenu of the [View] menu to open the [Stack Trace] window.

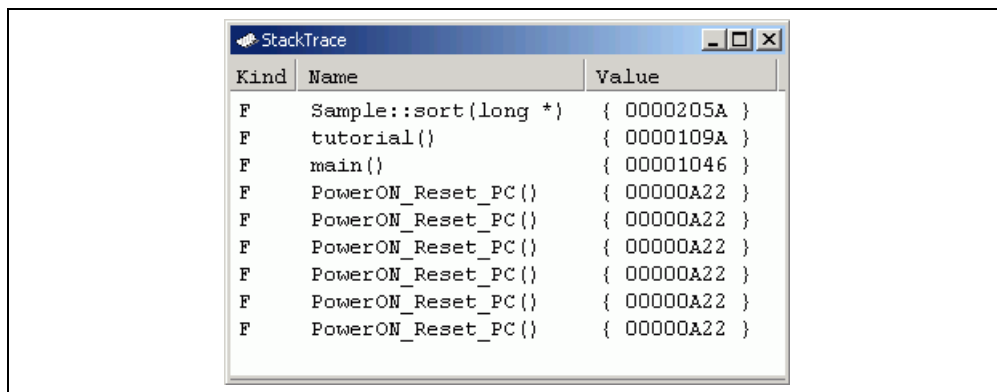

Figure 4.53 [Stack Trace] Window

Figure 4.53 shows that the position of the program counter is currently at the selected line of the `sort()` function, and that the `sort()` function is called from the `tutorial()` function.

To delete the software breakpoint, double-click the [S/W Breakpoints] column in the `sort` function again.

4.18 Performance Analysis Function

Performance analysis by the emulator is available in the following modes:

- Time Of Specified Range Measurement
- Start Point To End Point Measurement
- Start Range To End Range Measurement
- Access Count Of Specified Range Measurement
- Called Count Of Specified Range Measurement

In this tutorial, we describe the Time Of Specified Range Measurement.

4.18.1 Time Of Specified Range Measurement

- (1) Select [Performance Analysis] from the [Performance] submenu of the [View] menu to display the [Select Performance Analysis Type] dialog box.

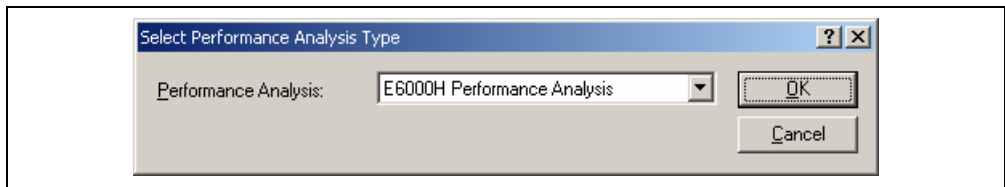

Figure 4.54 [Select Performance Analysis Type] Dialog Box

- (2) Select “E6000H Performance Analysis” from the [Performance Analysis] combo box in the [Select Performance Analysis Type] dialog box and click the [OK] button. The [Performance Analysis] window will be displayed.

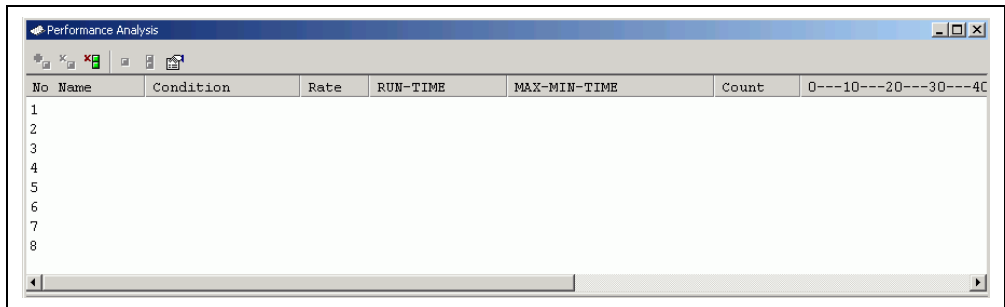

Figure 4.55 [Performance Analysis] Window

- (3) Select the line in the [Performance Analysis] window that has 1 in its [No] column and click the right-hand mouse button to display a popup menu. Select [Set...] from this popup menu to display the [Performance Analysis Properties] dialog box.

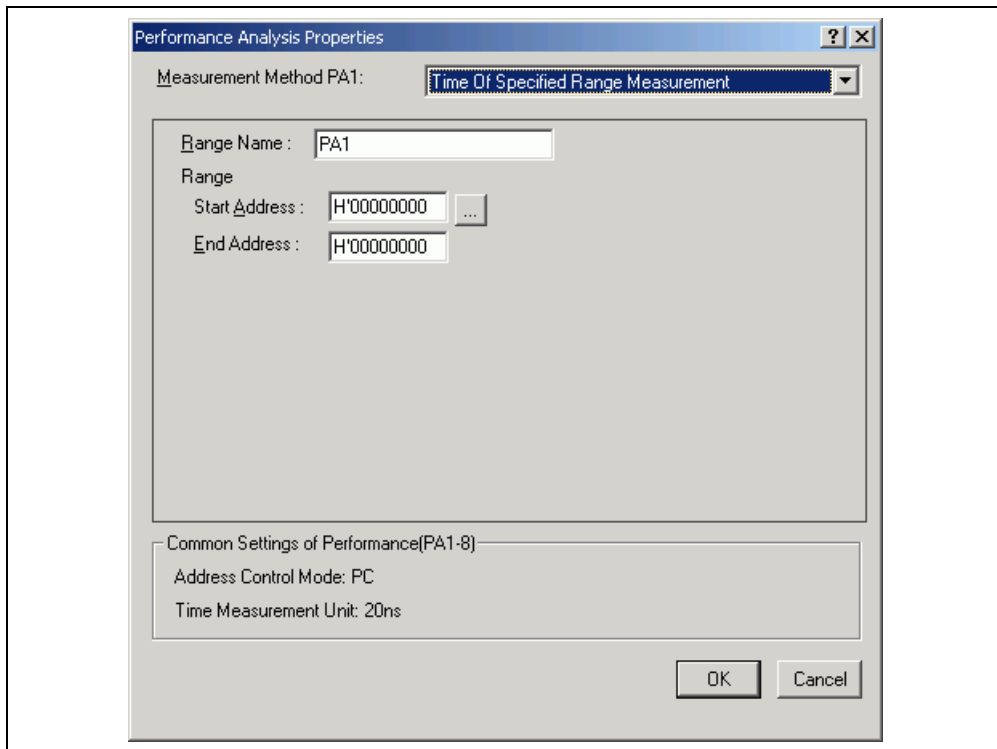

Figure 4.56 [Performance Analysis Properties] Dialog Box

- (4) Select *Time Of Specified Range Measurement* from the [Measurement Method PA1] combo box.
- (5) The parameter settings are as follows.
- Enter *sort* in the [Range Name] edit box.
 - Click the [...] button on the right of the [Start Address] edit box to display the [Input Function Range] dialog box. Enter the function name *sort* in the [Function] edit box in this dialog box and then click the [OK] button. The addresses for the function `Sample::sort(long*)` will now be set in the [Start Address] and [End Address] edit boxes.

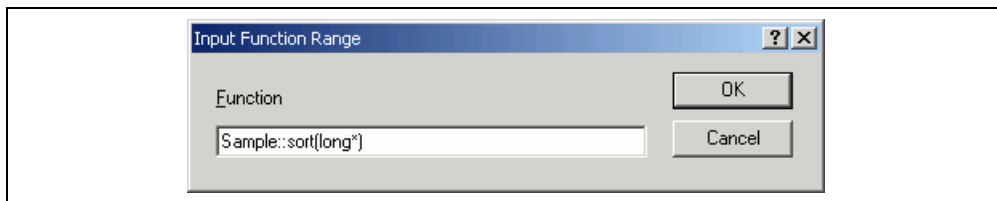

Figure 4.57 [Input Function Range] Dialog Box

Note: The addresses figured out in the [Input Function Range] dialog box are just for reference. In some cases, the end address of a function may be incorrect. Check the last instruction of the function in the [Disassembly] window to correct the value set in [End Address] so that it will be the address of the last instruction (in general, the last instruction of a function is a RTS instruction). A label name or an expression can be entered instead of an address value in boxes where an address should be entered.

- (6) Click the [OK] button to display the contents that has been set for line 1 of the [No] column in the [Performance Analysis] window. This completes the settings for measuring the time within the specified range.

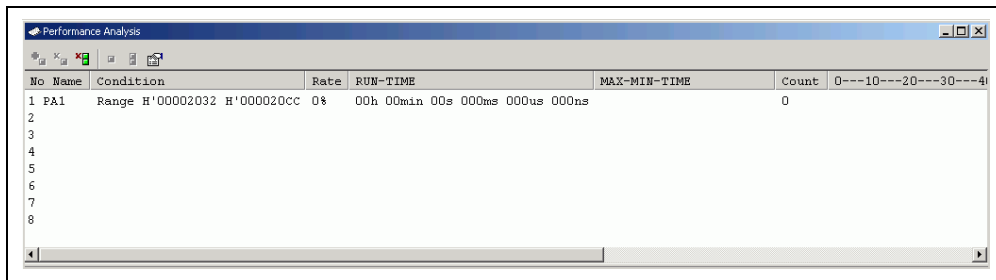

Figure 4.58 [Performance Analysis] Dialog Box (Setting Completed)

- (7) Set a software breakpoint at the address on the line that has 'p_sam->change(a);' within the tutorial function (H'0000109A in this example). Refer to section 4.15.1, Software Break Function.
- (8) Select [Reset Go] from the [Debug] menu. Execution stops when the break condition is satisfied, and the [Performance Analysis] window then displays the information shown below. The value shown in the [Count] column is 1, which indicates that the sort function has been executed once, and the execution time is also displayed. In this tutorial, the minimum unit for time measurement is defined as 20 ns. This value can be changed in the [Configuration Properties] dialog box.

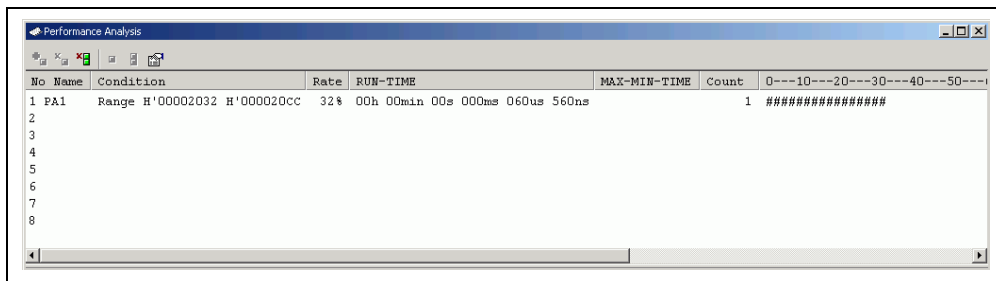

Figure 4.59 [Performance Analysis] Dialog Box (Displaying the Result)

- (9) Delete the settings for performance analysis and delete the event points. Click the right-hand mouse button on the [Performance Analysis] window to display a popup menu. Select [Reset All] from this popup menu to clear all of the settings. Clicking the right-hand mouse button on the [Event] window also displays a popup menu. Select [Delete All] from this popup menu to delete all the event points that have been set.

4.19 Profiling Function

The profiling function allows the user measure the performance for each of the functions.

(1) Select [Profile] from the [View] menu to open the [Profile] window.

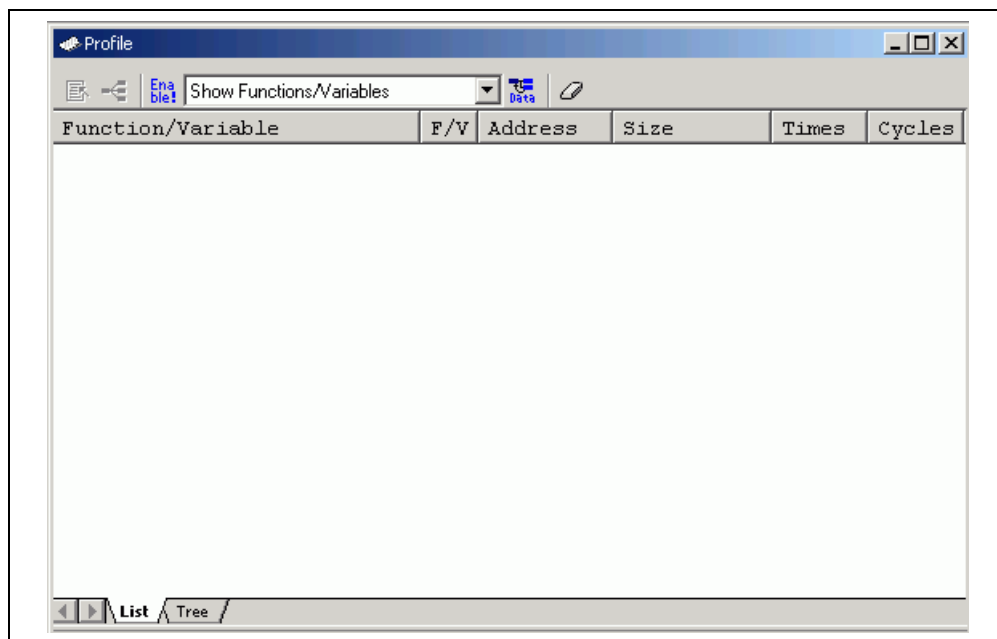

Figure 4.60 [Profile] Window ([List] Sheet)

- (2) To enable the profiling function, click the right-hand mouse button on the [Profile] window to show the popup menu and select [Enable Profiler].

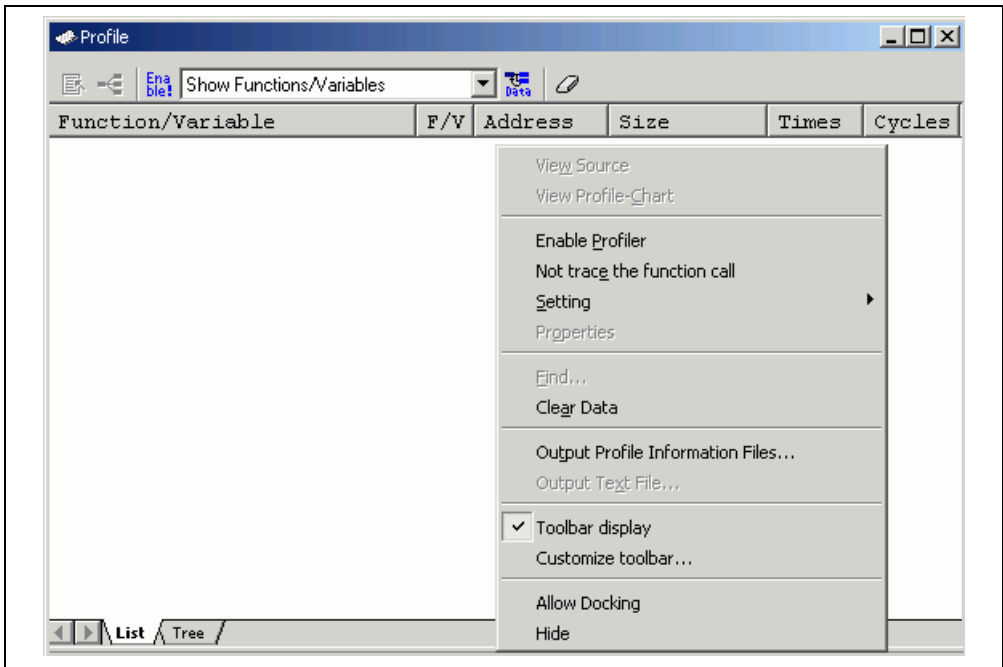

Figure 4.61 Selecting [Enable Profiler]

- (3) Set an on-chip breakpoint by an address condition at the line which includes “delete p_sam;” in the tutorial function (see section 4.15.2, On-Chip Break Function).

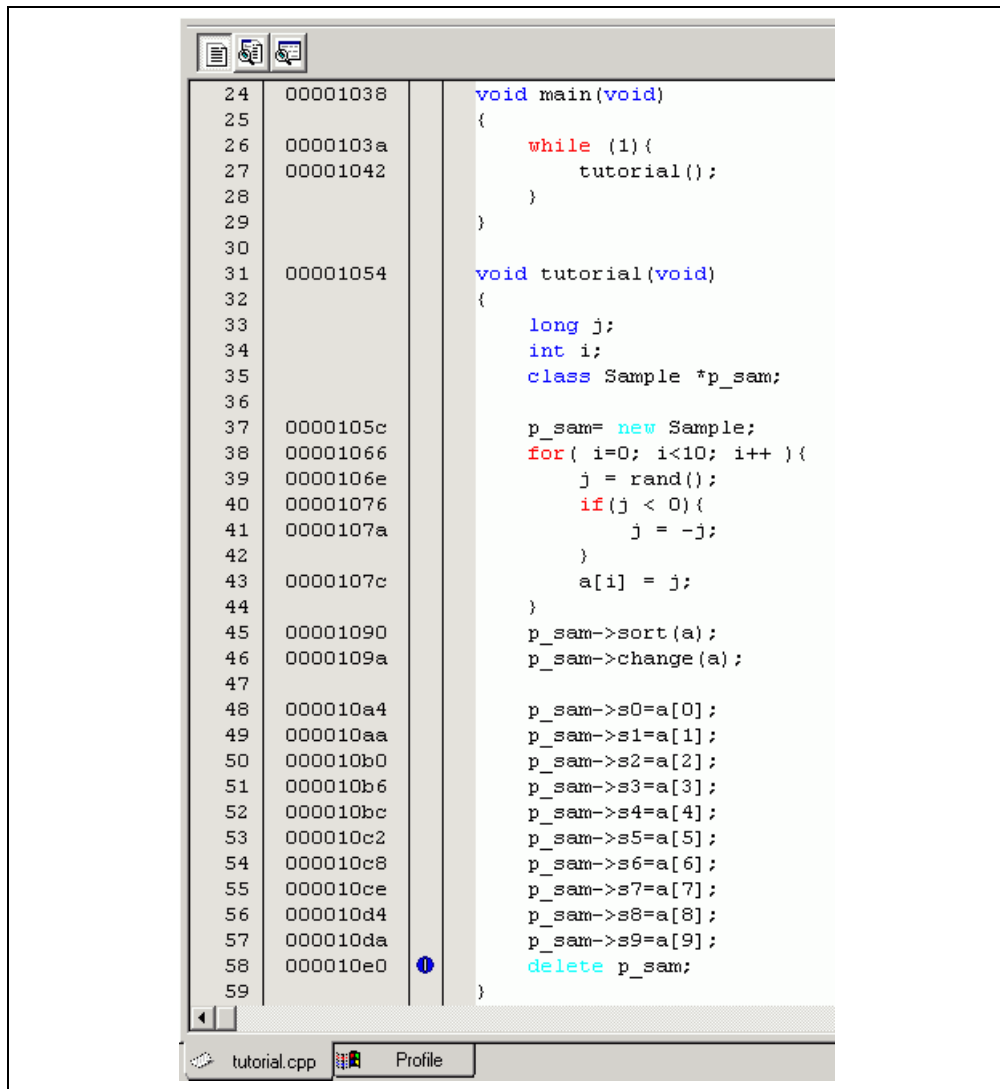
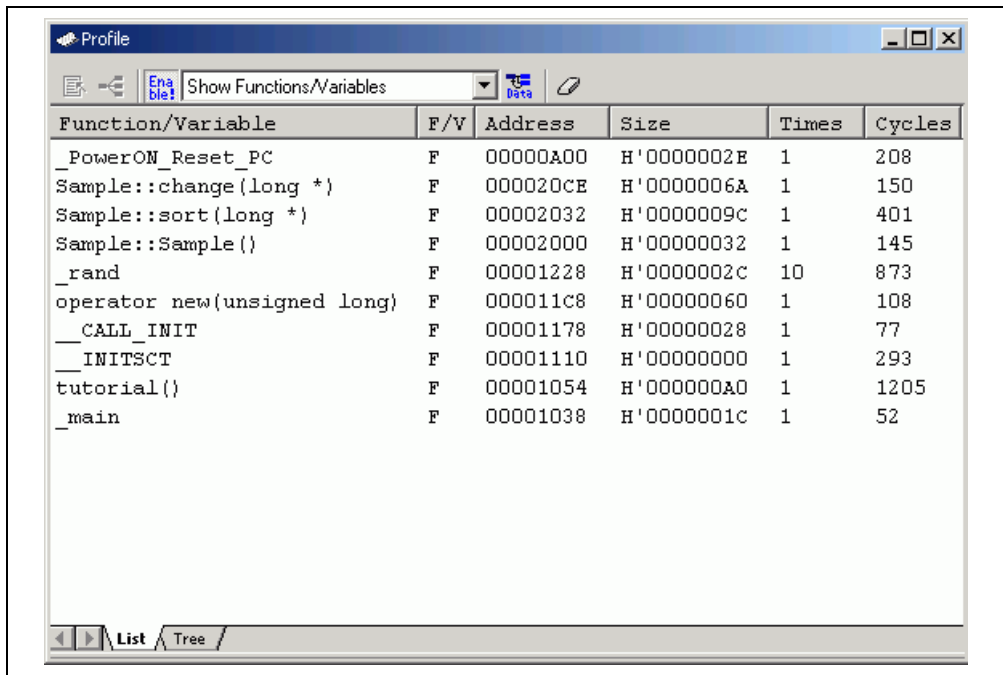

Figure 4.62 [Editor] Window (Setting an On-Chip Breakpoint)

- (4) To use the profiling function for measurement, select [Reset Go] from the [Debug] menu.

(5) The [Profile] window is shown below.



The screenshot shows a window titled "Profile" with a toolbar containing icons for "Show Functions/Variables" and "Data". Below the toolbar is a table with the following columns: Function/Variable, F/V, Address, Size, Times, and Cycles. The table lists several functions and variables, including _PowerON_Reset_PC, Sample::change(long *), Sample::sort(long *), Sample::Sample(), _rand, operator new(unsigned long), __CALL_INIT, __INITSCT, tutorial(), and _main. The bottom of the window has a tabbed interface with "List" and "Tree" tabs, where "List" is currently selected.

Function/Variable	F/V	Address	Size	Times	Cycles
_PowerON_Reset_PC	F	00000A00	H'0000002E	1	208
Sample::change(long *)	F	000020CE	H'0000006A	1	150
Sample::sort(long *)	F	00002032	H'0000009C	1	401
Sample::Sample()	F	00002000	H'00000032	1	145
_rand	F	00001228	H'0000002C	10	873
operator new(unsigned long)	F	000011C8	H'00000060	1	108
__CALL_INIT	F	00001178	H'00000028	1	77
__INITSCT	F	00001110	H'00000000	1	293
tutorial()	F	00001054	H'000000A0	1	1205
_main	F	00001038	H'0000001C	1	52

Figure 4.63 [Profile] Window ([List] Sheet)

(6) Click the [Tree] tab on the [Profile] window to display the [Tree] sheet.

Function	Address	Size	Stack Size	Times	Cycles
C:\Hew3\Tools\Renesas\DebugCo...					
_PowerON_Reset_PC	0000A00	H'0000002E	H'00000000	1	208
__INIT\$CT	00001110	H'00000000	H'00000000	1	293
__CALL_INIT	00001178	H'00000028	H'00000000	1	77
_main	00001038	H'0000001C	H'00000000	1	52
tutorial()	00001054	H'000000A0	H'00000000	1	1205
Sample::Sample()	00002000	H'00000032	H'00000000	1	145
Sample::change(long *)	000020CE	H'0000006A	H'00000000	1	150
Sample::sort(long *)	00002032	H'0000009C	H'00000000	1	401
_rand	00001228	H'0000002C	H'00000000	10	873

Figure 4.64 [Profile] Window ([Tree] Sheet)

- (7) Click the right-hand mouse button on the [Profile] window and select [View Profile-Chart] to open the [Profile-Chart] window.

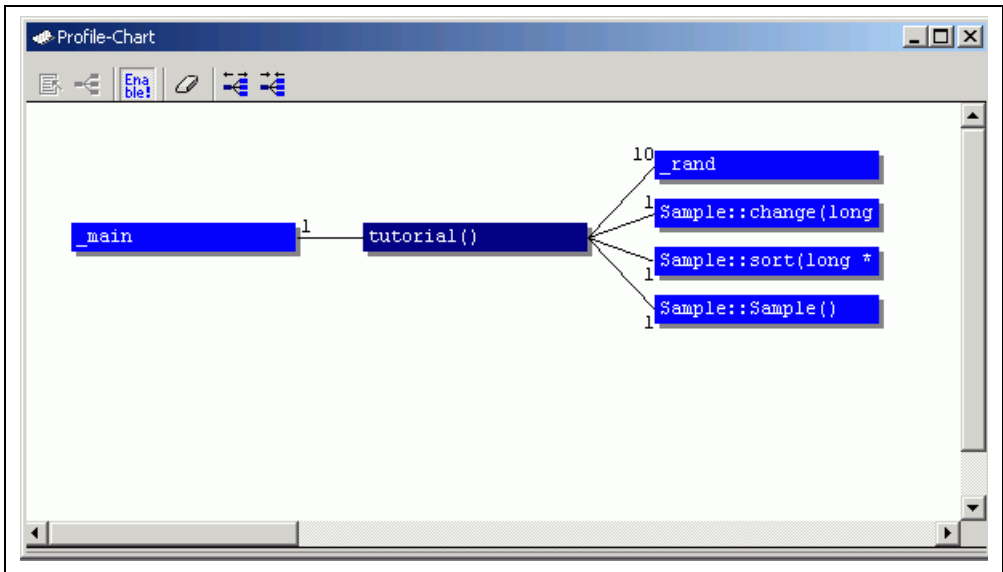

Figure 4.65 [Profile-Chart] Window

- (8) To disable the profiling function, uncheck [Enable Profiler] in the popup menu opened by clicking the right-hand mouse button on the [Profile] window. Delete all the break conditions that have been set.

4.20 Monitor Function

The emulator allows monitoring of the contents of specified addresses in memory during execution of the user program. In this example, we monitor the content of the address range where variable `a` of the `tutorial` function is stored.

- (1) Select the [CPU] submenu from the [View] menu. Selecting [Monitor Setting...] from the [Monitor] submenu displays the [Monitor Setting] dialog box.

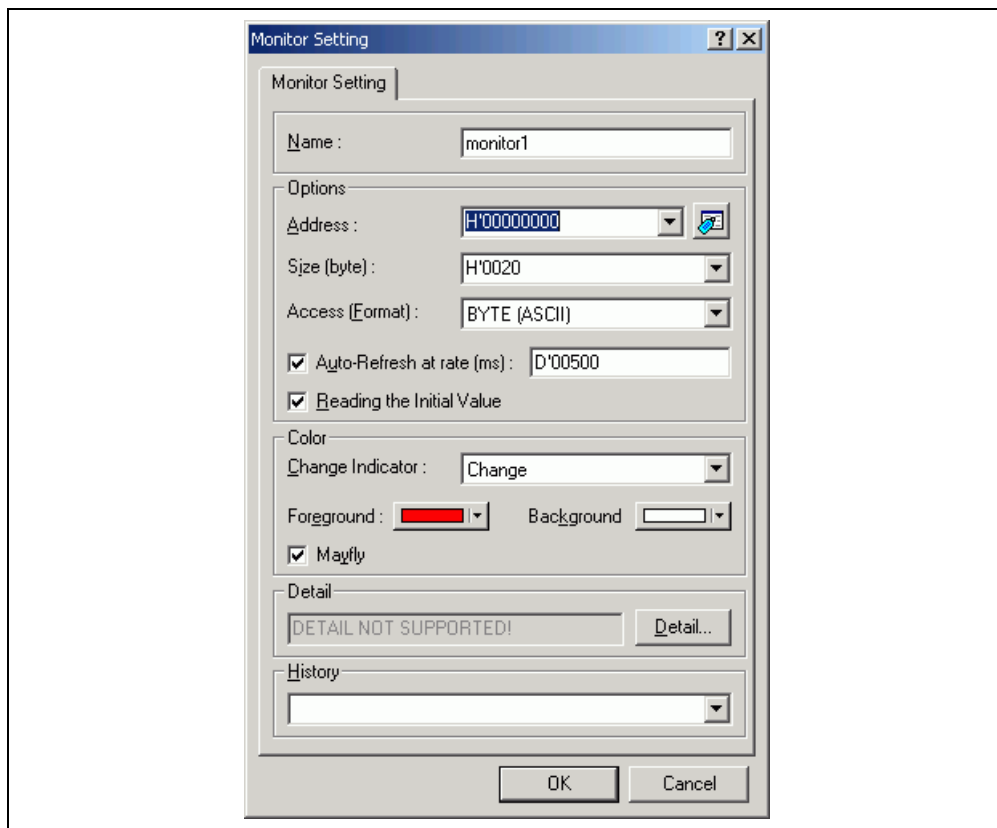

Figure 4.66 [Monitor Setting] Dialog Box

(2) Set the items in the [Monitor Setting] dialog box as follows:

- Enter **monitor1** in the [Name] edit box.
- Set the parameters in the [Options] group box as follows:
 - (a) Use the [Watch] window to refer to the address on the line where variable a, which is defined within the tutorial function, is allocated and enter this address in the [Address] edit box. In this example, **H'FFFF0400** is entered.
 - (b) Enter **H'20** in the [Size (byte)] combo box.
 - (c) Select **BYTE (ASCII)** from the [Access (Format)] combo box.
 - (d) Check the [Auto-Refresh at rate (ms)] check box and enter **D'00500** in the edit box.
 - (e) Check the [Reading the Initial Value] check box.
- Set the parameters in the [Color] group box as follows:
 - (a) Select **Change** from the [Change Indicator] combo box.
 - (b) Select **red** and **white** in the [Foreground] and [Background] combo boxes, respectively.
 - (c) Check the [Mayfly] check box.

Note: Depending on the operating system in use, the foreground and background colors may not be selectable.

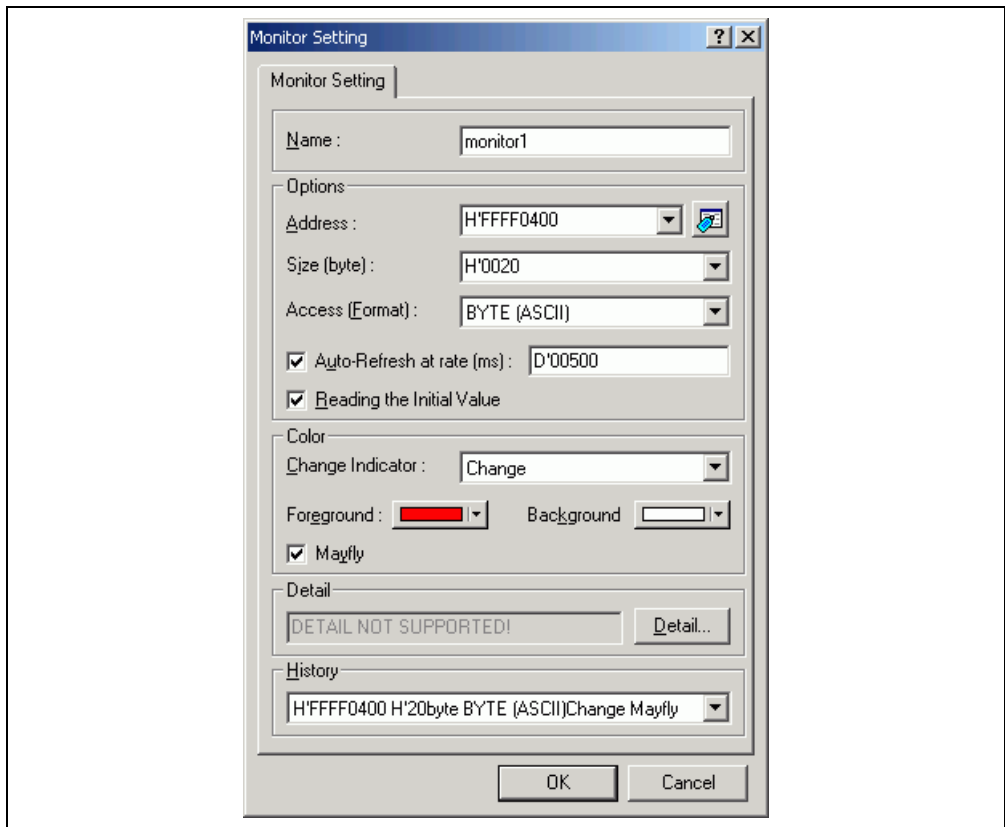

Figure 4.67 [Monitor Setting] Dialog Box (Setting Completed)

- (3) Click the [OK] button to open the [Monitor] window.

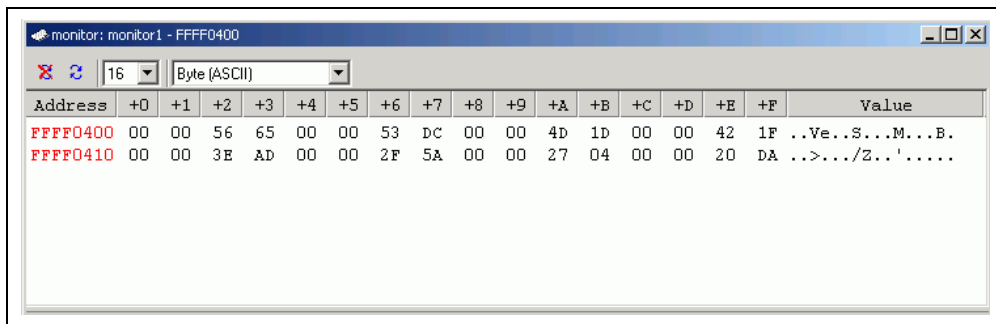

Figure 4.68 [Monitor] Window

- (4) Select [Reset Go] from the [Debug] menu. When the contents of the address range changes by execution, the updated values are in red (i.e. the color that was selected in the [Foreground] and [Background] combo boxes). Values will be displayed in black if they have not been updated or a certain period of time has elapsed since the last update.

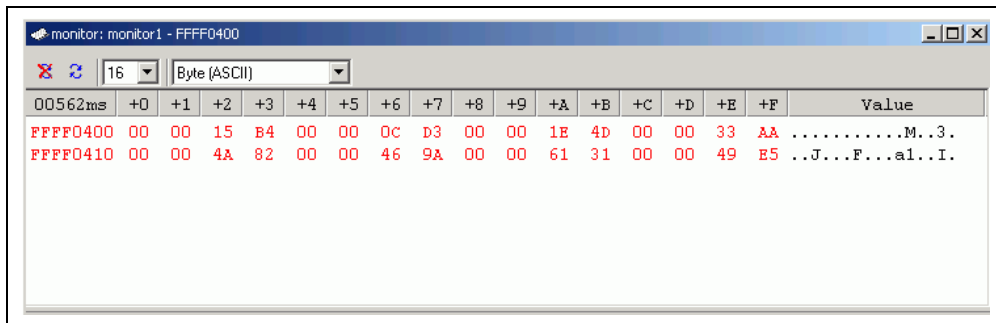

Figure 4.69 [Monitor] Window (during Execution)

- (5) After you have finished checking the states in the [Monitor] window, select [Halt Program] from the [Debug] menu to halt the program's execution.

4.21 What Next?

In this tutorial, some of the main features of the emulator and the High-performance Embedded Workshop operation have been given. By using the emulation functions provided by the emulator, a high-level debugging is possible. The conditions caused by hardware and software can be accurately classified and the users can investigate the problems effectively.

Section 5 Software Specifications and Notes Specific to This Product

This section describes the software specifications and notes specific to the E6000H emulator.

5.1 Supported Hardware

This emulator software is specialized for the SH7058 E6000H (HS7058EPH62H) and SH7058S, SH7059 E6000H (HS7059EPH62H) emulators.

5.2 Debugging Platform

The following debugging platform can be selected in this emulator. The target MCU to be emulated depend on the selected debugging platform.

Table 5.1 Selectable Debugging Platform

Debugging Platform	Description	Hardware
SH7058 E6000H Emulator CPU SH-2E	The SH7058 microcomputer can be emulated.	HS7058EPH62H
SH7058S E6000H Emulator CPU SH-2E	The SH7058S microcomputer can be emulated.	HS7059EPH62H
SH7059 E6000H Emulator CPU SH-2E	The SH7059 microcomputer can be emulated.	HS7059EPH62H

5.3 Displaying and Modifying the Contents of Memory

The emulator accesses memory in the following two ways to display and modify the contents of memory during user program execution.

Table 5.2 Access Types for Displaying and Modifying Contents of Memory

Access Type	Description	Period Suspended	Display	Modification
Monitor function	Automatically updates the display of the memory contents without stopping the user program execution. If the specified range is not accessed, the contents of memory will not be updated.	None	Enabled	Disabled
Parallel access function	For on-chip ROM and on-chip RAM areas, memory content displays are automatically updated without a halt during user program execution. When updating, a forced memory access occurs and realtime emulation will not be performed.	Short	Enabled	Enabled

These access types have the following characteristics.

Table 5.3 Characteristics of Displaying and Modifying Contents of Memory

Access Type	Target Window/Operation	Target Memory Area
Monitor function	Realtime update of display in the [Monitor] window and in the [Watch] window when the monitor function is used	Specified eight points or up to 256 bytes of the areas that the user program is allowed to access
Parallel access function	Windows that display the memory contents other than the [Monitor] window. Tooltip watch and instant watch. Command to display or modify the contents of memory.	All areas that the user program is allowed to access

Notes: 1. Memory contents cannot be displayed or modified by a parallel access in the sleep and standby modes.
2. When [Enable select AUD to Emulator (Enable read and write on the fly)] in the [Configuration Properties] dialog box is unchecked, reading memory by a parallel access during user program execution can be disabled. Uncheck [Enable select AUD to Emulator (Enable read and write on the fly)] for realtime user program execution.

5.3.1 Reference Values for Parallel Access Function Termination Period

Values for reference when the user program is terminated for displaying and modifying the memory contents during user program execution is given below.

Table 5.4 Reference Values of Termination Period

Access Method	Condition	Termination Period
Parallel access	Read: Longword-access read from on-chip RAM.	320 ns
	Write: Longword-access write to on-chip RAM.	320 ns
"Auto update Memory"	User program execution is not terminated.	

Table 5.5 Measurement Environment

Item	Set Value
System clock (ϕ)	10.0 MHz
Clock mode	Clock mode 3
H-UDI clock	5.0 MHz

5.3.2 Monitor Function

- Up to eight points or 256 bytes in total can be specified for the monitor function.
- The monitor function is implemented by eight 32-byte hardware channels. The address range specified for one channel must be aligned to a 32-byte boundary; two channels should be used to specify a range across a 32-byte boundary. Accordingly, when multiple ranges are specified across 32-byte boundaries, the total specifiable size is less than 256 bytes.
- When monitor function conditions are set or modified during user program execution, the program is not executed in realtime.
- When [Access Size and Display Format] are modified during user program execution, the program is not executed in realtime.

5.3.4 Note on Accessing Memory

In the single-chip mode, do not access (i.e. display or modify memory contents) the external memory space of H'00200000 to H'7FFFFFFF in the [Memory] window. If this is done, an address error will occur.

5.4 Executing Your Program

5.4.1 Step Execution

Break conditions are ignored during step execution, but trigger pulses will be output.

5.4.2 Break Suspension

The break processing may be suspended for some instructions which are being executed when the break condition is satisfied. The suspended break will be generated when the emulator enters the state that can accept a break. The instructions for which a break is suspended is listed in the table below.

Table 5.6 Instructions for which a Break is Suspended

Instruction	Description
Delayed branch instruction	JMP, JSR, BRA, BSR, RTS, RTE, BF/S, BT/S, BSRF, BRAF
FPU instruction	Floating-point instructions of the FPU instruction, and CPU instructions concerning the FPU

Note: Software breaks are not suspended since they are realized by replacing the instructions.

The emulator internally sets break conditions to realize step execution functions. Accordingly, when the above instructions are executed in steps, the program execution may continue until the emulator enters the state that can accept breaks.

5.5 Event Functions

5.5.1 Software Breakpoints

- A software breakpoint is realized by replacing the instruction at the specified address with a special instruction. Accordingly, it can only be set to the area including the emulation RAM. Note that it cannot be set to the following addresses:
 - Addresses whose memory content is H'0000
- Do not modify the contents of the software breakpoints addresses by the user program.
- The content of a software breakpoint address is replaced by a break instruction during user program execution.
- The maximum number of software breakpoints and temporary PC breakpoints in [Temporary PC Breakpoints] of the [Run Program] dialog box is 255 in total. Therefore, when 255 software breakpoints have been set, no temporary breakpoint set in [Temporary PC Breakpoints] of the [Run Program] dialog box is valid. Ensure that the total number of software breakpoints and temporary PC breakpoints are 255 or less.
- Do not set a breakpoint immediately after a delayed branch instruction (at a slot instruction). If this is attempted, a slot illegal instruction interrupt will occur when the delayed branch instruction is executed, and the break will not occur.

5.5.2 On-Chip Break

- The satisfaction count can only be set for channel 8.
- The address and data conditions are satisfied on the bus cycles where the values on the address bus or data bus match. Consider the following points when setting these conditions.
 - Longword access
Longword data is read and written in a single bus cycle. A data condition is only valid for a longword access when specified as longword. The specified address must be a multiple of four. Note that longword data is only valid as the size of an access.
 - Word access
Word data is read and written in a single bus cycle. The specified address must be a multiple of two. Word data is only valid as the size of an access.
 - Byte access
Byte data is read and written in a single bus cycle. A data condition is only valid for a byte access when specified as byte. Any address condition, both an even and odd address, are valid.

5.5.3 On-Emulator Break

- A break will occur several cycles after a condition is satisfied.
- The address and data conditions are satisfied on the bus cycles where the values on the address bus or data bus match. Consider the following points when setting these conditions.
 - Longword access
Longword data is read and written in a single bus cycle. A data condition is only valid for a longword access when specified as longword. The specified address must be a multiple of four.
 - Word access
Word data is read and written in a single bus cycle. Word data is only valid as the size of an access. The specified address must be a multiple of two.
 - Byte access
Byte data is read and written in a single bus cycle. A data condition is only valid for a byte access when specified as byte. Any address condition, both an even and odd address, are valid.

Use the mask function so that no invalid data of a 32-bit data bus will be applied as a condition to search data.

5.6 Trace Functions

5.6.1 Displaying the Trace Information

- The same hardware resource is used for acquisition of time stamps and the IRQ signals in the trace function. Accordingly, the trace contents differ depending on the [Selection of the trace contents] setting in the [Trace Acquisition Properties] dialog box.

Table 5.7 Trace Contents

Setting	Description
When [Timestamp] is selected	Acquires and displays timestamp in 32 bits. The IRQ signals are not acquired.
When [IRQ7-0 all indications] is selected	Acquires and displays the IRQ signals. The time stamp is displayed with the lower 16 bits fixed to 0.

- When the user clock (internal clock signal ϕ) has been selected for [Time measurement unit] in the [Trace acquisition] dialog box, the time stamp is displayed for 32 bits in hexadecimal.

5.6.2 Specifying Trace Acquisition Conditions

- The trace will stop several cycles after a condition is satisfied.
- Six or more bus cycles are required between pass points of sequential trace stop conditions and reset condition.
- Six or more bus cycles are required between the start and end of measurement when [1-2], [3-4], or [5-6] is specified in [Run time count between trigger outputs] of the [Trace Acquisition Properties] dialog box.
- Fifteen or more bus cycles are required between the start and end of measurement when [7-8] is specified in [Run time count between trigger outputs] of the [Trace Acquisition Properties] dialog box.
- Six or more bus cycles are required from the start of execution to satisfaction of a trace stop mode condition.
- A sequential break or a trace stop may be incorrect when the user program is executed after the specified address condition has been applied as the PC address to start execution.
- The Point to Point trace mode is not available when channel 1 is used for the performance analysis function.

5.6.3 Searching for a Trace Record

- When the range for searching is specified in the [General] page, a PTR value to end the search can be specified in the [Start PTR] option, and a PTR value to start the search can be specified in the [End PTR].
- When the user clock (i.e. internal clock signal ϕ) has been selected in [Time measurement unit] of the [Trace Acquisition Properties] dialog box, no time stamp information will be searched.

5.6.4 Filtering Trace Records

- After the trace information is filtered, all trace information displayed in the [Trace] window is saved; a range for saving trace information cannot be specified. To save a specific range of trace information, the filter range must be specified in the [General] page of the [Trace Filter] dialog box.
- When the user clock (i.e. internal clock signal ϕ) has been selected in [Time measurement unit] of the [Trace Acquisition Properties] dialog box, no time stamp information will be filtered.

5.7 Monitor Function

The foreground and background colors cannot be changed in some operating systems.

5.8 Performance Analysis Function

5.8.1 Errors

An error will be included in the measured performance as follows:

- \pm one-resolution error (± 20 -ns error when the measurement resolution is 20 ns)
This error may occur when the user program execution starts or stops (breaks) or when the measurement start or end condition is satisfied.
- Frequency stability of the crystal oscillating module for performance analysis: $\pm 0.01\%$

5.8.2 Notes

- In all measurement modes, the interval between the end condition satisfaction and the next start condition satisfaction must be longer than one-measurement-resolution time. If the interval is shorter than that, the interval itself is included in the measured time.
- In [Time Of Specified Range Measurement], measurement stops when an instruction is fetched outside the specified range. In [Start Point To End Point Measurement] and [Start Range To End Range Measurement], measurement stops when the specified end condition is satisfied. When the same addresses are specified for these modes, the time measured in [Time Of Specified Range Measurement] is longer than that measured in [Start Point To End Point Measurement] or [Start Range To End Range Measurement].
- Execution time is measured by using address bus values in prefetch cycles. If the end address condition is specified at an address near the instruction following a branch instruction or delayed slot instruction, correct time cannot be measured. Check the bus trace display for the operation after the branch instruction prefetch cycle, and specify the end address condition at the address in a prefetch cycle which will not be executed by the branching.
- Channel 1 is not available for performance analysis when the Point to Point trace mode is selected.
- The resolution for the performance analysis function can be set in [Timer Resolution] of the [Configuration Properties] dialog box. If the clock counter value is set as the resolution, the value shown in [RUN-TIME] and [MAX-MIN-TIME] will be that of the clock counter (displayed in hexadecimal).
- The counter for measurement has 24 bits, and the maximum measurement time is as given below depending on the value set in [Timer Resolution].

Table 5.8 Maximum Measurement Time

Value of [Timer Resolution]	Maximum Measurement Time
52 us	Approximately 14 minutes
1.6 us	Approximately 26 seconds
20 ns	Approximately 0.33 second

- The maximum measurement count for Access Count of Specified Range Measurement and Called Count of Specified Range Measurement is 65,535.

5.9 Profiling Function

- If there is no stack information file (extension is '.sni') that is output from the optimizing linkage editor, only the functions that have been executed during the profiling data measurement are displayed. For details of the stack information file, refer to the manual of the optimizing linkage editor.
- The stack size differs from the actual value. It should be used as a reference value during a function call. If there is no stack information file (extension is '.sni') that is output from the optimizing linkage editor, the stack size is not displayed.
- While the profiling function is used, software break and on-emulator break, which are event functions, are not available.
- While the profiling function is used, the parallel access function during user program execution is not available.
- Since the profiling function internally breaks user program execution, the program is not executed in realtime. The measured value includes an error.
- The profiling function internally uses the on-chip break channels 9 to 12. Therefore, break channels 9 to 12 cannot be used when the profiling function is used.
- [Cycle] displays a decimal value of the counter for measurement of execution time. The resolution for the counter for measurement of execution time can be set in [Timer Resolution] of the [Configuration Properties] dialog box. The expression for the execution time of each function is as follows:
Execution time = Value of the [Cycle] item × Value of [Time Resolution]
- To enable the profiling function, [Enable select AUD to Emulator (Enable read and write on the fly)] must be unchecked in the [Configuration Properties] dialog box.

5.10 Input Format

5.10.1 Entering Masks

Address bus conditions and data bus conditions can be input with masks. Addresses can be masked in 1-, 3-, or 4-bit units. When a bit is masked, it always satisfies the condition.

To specify a mask for an address bus condition, specify the mask value in the [Mask] area.

The mask for data conditions is similarly specified in the [Mask] area.

To specify any further mask, specify 1 for the digits to be ignored. Examples of mask specification are listed below.

Table 5.9 Address Mask Specification

Input Value	Mask Unit	Example	Masked Bits
Binary	1 bit	B'00000111	Masks bits 0 to 2
Octal	3 bits	O'000017	Masks bits 0 to 3
Hexadecimal	4 bits	H'07FF	Masks bits 0 to 10

5.11 Downloading a Program

Before downloading a program to the on-chip flash memory, the input frequency and the method for loading to the on-chip flash memory must be set in the [Configuration Properties] dialog box. For details on the [Configuration Properties] dialog box, refer to section 3.1, Setting the Environment for Emulation.

5.12 Tutorial Program

5.12.1 Downloading the Tutorial Program

The setting of the emulation RAM is applied in the area in which downloading of the tutorial program is necessary for the workspace of the tutorial program attached to this product. When the tutorial program is downloaded according to the procedure of section 4, Tutorial, the tutorial program is downloaded in the emulation RAM, not in the on-chip flash memory. To download the tutorial program to the on-chip flash memory, the setting of the input frequency and the loading method is required in the [Configuration Properties] dialog box beforehand. Note, however, that you do not need to download the tutorial program to the on-chip flash memory to operate the High-performance Embedded Workshop according to the description of section 4, Tutorial.

For description on setting the emulation RAM and how to download a program to the on-chip flash memory, refer to section 3.1, Setting the Environment for Emulation.

5.12.2 Notes on Operating the Tutorial Program

To operate the High-performance Embedded Workshop according to the description of section 4, Tutorial, the following procedures must be added or modified.

Table 5.12 Notes on Operating the Tutorial Program

4.6 Executing the Program	Reset the target MCU before executing the program. Refer to section 4.14, Resetting the Target MCU for how to reset the target MCU.
4.12.3 Executing the [Step Over] Command	In this product, after execution of [Step Out], execution stops at the statement where the <code>sort</code> function is called. Before executing the [Step Over] command, execute the [Step In] command once so that the execution stops at the statement where the <code>change</code> function is called.
4.19 Profiling Function	Before enabling the profiling function, ensure that [Enable select AUD to Emulator (Enable read and write on the fly)] in the [Configuration Properties] dialog box is unchecked.

Section 6 Error Messages

6.1 Error Messages of the Emulator

6.1.1 Error Messages at Emulator Initiation

The emulator displays error messages in the format below if an error occurs at emulator initiation in the dedicated message dialog box when the High-performance Embedded Workshop is used.

Table 6.1 lists error messages at emulator initiation.

Table 6.1 Error Messages at Initiation

Error Message	Description and Solution
There is no configuration file.	The configuration file that is required to initiate the emulator cannot be found. Exit and re-install the High-performance Embedded Workshop. Then re-connect the user system interface cable, turn on the power of the emulator, and re-initiate the High-performance Embedded Workshop. If the problem is not solved, contact us and describe the error occurrence in detail.
The contents of the configuration file are incorrect.	The configuration file that is required to initiate the emulator is invalid. Exit and re-install the High-performance Embedded Workshop. Then re-connect the user system interface cable, turn on the power of the emulator, and re-initiate the High-performance Embedded Workshop. If the problem is not solved, contact us and describe the error occurrence in detail.
Main Board not Support (XX XX XX) Emulator is switched off or not connected	The emulator power is not turned on, or the user system interface cable is not connected. Exit the High-performance Embedded Workshop, re-connect the user system interface cable, turn on the power of the emulator, and re-initiate the High-performance Embedded Workshop. If the problem is not solved, contact us and describe the error occurrence in detail.
Emulation Board not Support (XX XX XX) Emulator is switched off or not connected	The emulator power is not turned on, or the user system interface cable is not connected. Exit the High-performance Embedded Workshop, re-connect the user system interface cable, turn on the power of the emulator, and re-initiate the High-performance Embedded Workshop. If the problem is not solved, contact us and describe the error occurrence in detail.
EVA chip Board not Support (XX XX XX) Emulator is switched off or not connected	The emulator power is not turned on, or the user system interface cable is not connected. Exit the High-performance Embedded Workshop, re-connect the user system interface cable, turn on the power of the emulator, and re-initiate the High-performance Embedded Workshop. If the problem is not solved, contact us and describe the error occurrence in detail.
Can't initialize G/A registers	An error occurred during the initialization of the emulator. Exit the High-performance Embedded Workshop, re-connect the user system interface cable, turn on the power of the emulator, and re-initiate the High-performance Embedded Workshop. If the problem is not solved, contact us and describe the error occurrence in detail.
There is no effective clock source	A valid clock source cannot be found. Connect a valid clock source.
This mode can not specify	The state of mode pins for the target board is incorrect. Initiation is only possible in mode 4. Set the mode pins correctly.

Table 6.1 Error Messages at Initiation (cont)

Error Message	Description and Solution
Can't find firmware file Firmware open Error Firmware Download Error Firmware Name Error	There is an error in the file that is required at emulator initiation. Exit the High-performance Embedded Workshop, re-connect the user system interface cable, turn on the power of the emulator, and re-initiate the High-performance Embedded Workshop. If the problem is not solved, contact us and describe the error occurrence in detail.
Failed to receive a firmware initialization command.	Initiation of the emulator firmware has failed. Exit the High-performance Embedded Workshop, re-connect the user system interface cable, turn on the power of the emulator, and re-initiate the High-performance Embedded Workshop. If the problem is not solved, contact us and describe the error occurrence in detail.
Target system is Vcc down	The value of Vcc is lower than the specified threshold value.
JTAG Timeout Srval Error JTAG Packet Receive Error	Exit the High-performance Embedded Workshop, re-connect the user system interface cable, turn on the power of the emulator, and re-initiate the High-performance Embedded Workshop.

6.1.2 Error Messages during Emulation

The emulator displays error messages if an error occurs during emulation in the dedicated message dialog box when the High-performance Embedded Workshop is used, and on the status bar. Table 6.2 lists error messages during emulation.

Table 6.2 Error Messages during Emulation

Error Message	Description and Solution
Communication DLL error. Communication Timeout error.	The power of the emulator is turned off or there is a communication error. Exit the High-performance Embedded Workshop, re-connect the user system interface cable, turn on the power of the emulator, and re-initiate the High-performance Embedded Workshop. If the problem is not solved, contact us and describe the error occurrence in detail.
Parallel Access Error	An error has occurred during a parallel access. Parallel accesses are disabled until a break occurs.

Appendix A Menus

Table A.1 shows GUI menus.

Table A.1 GUI Menus



















Menu	Option	Shortcut	Toolbar Button	Remarks
View	Command Line	Ctrl + L		Opens the [Command Line] window.
	Workspace	Alt + K		Opens the [Workspace] window.
	Output	Alt + U		Opens the [Output] window.
	Disassembly	Ctrl + D		Opens the [Disassembly] window.
CPU	Registers	Ctrl + R		Opens the [Register] window.
	Memory...	Ctrl + M		Opens the [Memory] window.
	IO	Ctrl + I		Opens the [IO] window.
	Status	Ctrl + U		Opens the [Status] window.
	Extended Monitor			Opens the [Extended Monitor] window.
	Monitor	Monitor Setting... Windows Select...	Shift + Ctrl + E	
Sym- bol	Labels	Shift + Ctrl + A		Opens the [Labels] window.
	Watch	Ctrl + W		Opens the [Watch] window.
	Locals	Shift + Ctrl + W		Opens the [Locals] window.
Code	Eventpoints	Ctrl + E		Opens the [Event] window.
	Trace	Ctrl + T		Opens the [Trace] window.
	Code Coverage...	Shift + Ctrl + H		Opens the [Code Coverage] window.
	Data coverage...	Shift + Ctrl + Z		Opens the [Data Coverage] window.
	Stack Trace	Ctrl + K		Opens the [Stack Trace] window.

Table A.1 GUI Menus (cont)











Menu	Option	Shortcut	Toolbar Button	Remarks	
View (cont)	Graphic	Image...	Shift + Ctrl + G		Opens the [Image] window.
		Waveform...	Shift + Ctrl + V		Opens the [Waveform] window.
	Performance	Performance Analysis	Shift + Ctrl + P		Opens the [Performance Analysis] window.
		Profile	Shift + Ctrl + F		Opens the [Profile] window.
Debug	Debug Sessions...				Opens the [Debug Sessions] dialog box to list, add, or remove the debug session.
	Debug Settings...				Opens the [Debug Settings] dialog box to set the debugging conditions or download modules.
	Reset CPU				Resets the target hardware and sets the PC to the reset vector address.
	Go		F5		Starts executing the user program at the current PC.
	Reset Go		Shift + F5		Resets the target hardware and executes the user program from the reset vector address.
	Go To Cursor				Starts executing the user program at the current PC until the PC reaches the address indicated by the current text cursor position.
	Set PC To Cursor				Sets the PC to the address at the row of the text cursor.
	Run...				Launches the [Run Program] dialog box allowing the user to enter the PC or PC breakpoint during executing the user program.
	Display PC		Shift+Ctrl +Y		Opens the [Editor] or [Disassembly] window at the address of the PC.

Table A.1 GUI Menus (cont)













Menu	Option	Shortcut	Toolbar Button	Remarks	
Debug (cont)	Step In	F11		Executes a block of user program before breaking.	
	Step Over	F10		Executes a block of user program before breaking. If a subroutine call is reached, then the subroutine will not be entered.	
	Step Out	Shift + F11		Executes the user program to reach the end of the current function.	
	Step...			Launches the [Step Program] dialog box allowing the user to modify the settings for stepping.	
	Step Mode	Auto		Steps only one source line when the [Editor] window is active. When the [Disassembly] window is active, stepping is executed in a unit of assembly instructions.	
		Assembly		Executes stepping in a unit of assembly instructions.	
		Source		Steps only one source line.	
	Halt Program		Esc		Stops the execution of the user program.
	Initialize				Disconnects the emulator and connects it again.
	Connect				Connects the emulator.
Disconnect				Disconnects the emulator.	
Save Memory...				Saves the specified memory area data to a file.	
Verify Memory...				Verifies file contents against memory contents.	
Configure Overlay...				Selects the target section group when the overlay function is used.	
Download Modules				Downloads the object program.	
Unload Modules				Unloads the object program.	

Table A.1 GUI Menus (cont)

Menu	Option	Shortcut	Toolbar Button	Remarks	
Setup	Customize...			Customize the High-performance Embedded Workshop application.	
	Options...			Sets option of the High-performance Embedded Workshop application.	
	Format Views...			Configure fonts, colors, keywords and so on, for the window.	
	Radix	Hexadecimal			Uses a hexadecimal for displaying a radix in which the numerical values will be displayed and entered by default.
		Decimal			Uses a decimal for displaying a radix in which the numerical values will be displayed and entered by default.
	Octal			Uses an octal for displaying a radix in which the numerical values will be displayed and entered by default.	
	Binary			Uses a binary for displaying a radix in which the numerical values will be displayed and entered by default.	
Emulator	System...			Opens the [Configuration Properties] dialog box allowing the user to modify the emulator settings.	

Appendix B Command Lines

Table B.1 lists the High-performance Embedded Workshop commands.

Table B.1 High-performance Embedded Workshop Commands

No.	Command Name	Abbreviation	Function
1	!	-	Comment
2	ADD_FILE	AF	Adds a file to the current project
3	ANALYSIS	AN	Enables or disables performance analysis
4	ANALYSIS_RANGE	AR	Sets or displays a performance analysis range
5	ANALYSIS_RANGE_DELETE	AD	Deletes a performance analysis range
6	ASSEMBLE	AS	Assembles instructions into memory
7	ASSERT	-	Checks if an expression is true or false
8	AUTO_COMPLETE	AC	Enables or disables the auto-complete function
9	BREAKPOINT_ONCHIP	BC	Displays on-chip breakpoints, sets sequential breaks, and sets PtoP time measurement
10	BREAKPOINT_ONCHIPn	BCn	Sets on-chip breakpoint of each channel
11	BREAKPOINT_ONCHIP_CLEAR	BCC	Clears on-chip breakpoints
12	BREAKPOINT_ONCHIP_ENABLE	BCE	Enables or disables an on-chip breakpoint
13	BREAKPOINT_ONEMULATOR	BE	Displays on-emulator breakpoints
14	BREAKPOINT_ONEMULATORn	BE n	Sets on-emulator breakpoint of each channel
15	BREAKPOINT_ONEMULATOR_CLEAR	BEC	Clears on-emulator breakpoints
16	BREAKPOINT_ONEMULATOR_ENABLE	BEE	Enables or disables an on-emulator breakpoint
17	BREAKPOINT_SOFTWARE	BS	Sets a software breakpoint
18	BREAKPOINT_SOFTWARE_CLEAR	BSC	Clears software breakpoints
19	BREAKPOINT_SOFTWARE_ENABLE	BSE	Enables or disables a software breakpoint
20	BUILD	BU	Performs a build on the current project
21	BUILD_ALL	BL	Performs a build all on the current project
22	CHANGE_CONFIGURATION	CC	Sets the current configuration
23	CHANGE_PROJECT	CP	Sets the current project
24	CHANGE_SESSION	CS	Changes the current session
25	CLOSE_WORKSPACE	CW	Close the current workspace
26	CONFIGURE_PLATFORM	CPF	Sets the debugging environment for the emulator
27	DEFAULT_OBJECT_FORMAT	DO	Sets the default object (program) format
28	DEVICE_TYPE	DE	Selects a device type to emulate

Table B.1 High-performance Embedded Workshop Commands (cont)

No.	Command Name	Abbreviation	Function
29	DISASSEMBLE	DA	Disassembles memory contents
30	EMULATOR_CLOCK	ECK	Selects the clock rate of the target MCU for the emulator
31	ERAM	ERM	Sets the ERAM or displays the ERAM setting
32	ERASE	ER	Clears the [Command Line] window
33	EVALUATE	EV	Evaluates an expression
34	EXMONITOR_DISPLAY	EXMD	Displays the content of the expansion monitor
35	EXMONITOR_SET	EXMS	Selects whether or not to display the items in the expansion monitor
36	EXMONITOR_SETRATE	EXMSR	Sets the time to update the expansion monitor during emulation or a break
37	FILE_LOAD	FL	Loads an object (program) file
38	FILE_SAVE	FS	Saves memory to a file
39	FILE_UNLOAD	FU	Unloads a file
40	FILE_VERIFY	FV	Verifies file contents against memory
41	FLASH_MEMORY	FLM	Erases the contents of the flash memory
42	GENERATE_MAKE_FILE	GM	Creates a makefile to be built outside the High-performance Embedded Workshop
43	GO	GO	Executes user program
44	GO_RESET	GR	Executes user program from reset vector
45	GO_TILL	GT	Executes user program until temporary breakpoint
46	HALT	HA	Halts the user program
47	HELP	HE	Displays the command line help
48	INITIALIZE	IN	Initializes the debugging platform
49	JTAG_CLOCK	JCK	Sets and displays the JTAG clock (TCK)
50	LOG	LO	Controls command output logging
51	MAP_DISPLAY	MA	Displays memory mapping
52	MEMORY_COMPARE	MC	Compares memory contents
53	MEMORY_DISPLAY	MD	Displays memory contents
54	MEMORY_EDIT	ME	Modifies memory contents
55	MEMORY_FILL	MF	Modifies the content of a memory area by specifying data
56	MEMORY_FIND	MI	Searches for data within the memory range
57	MEMORY_MOVE	MV	Moves a block of memory
58	MEMORY_TEST	MT	Tests a block of memory
59	MODE	MO	Sets or displays the MCU mode
60	MONITOR_CLEAR	MOC	Deletes a monitor point
61	MONITOR_DISPLAY	MOD	Displays the content of the monitor
62	MONITOR_REFRESH	MOR	Controls an automatic update of the content of the monitor
63	MONITOR_SET	MOS	Sets or displays a monitor point
64	OPEN_WORKSPACE	OW	Opens a workspace
65	PROFILE	PR	Enables or disables the profile
66	PROFILE_DISPLAY	PD	Displays profiling results

Table B.1 High-performance Embedded Workshop Commands (cont)

No.	Command Name	Abbreviation	Function
67	PROFILE_SAVE	PS	Saves profiling results
68	QUIT	QU	Exits High-performance Embedded Workshop
69	RADIX	RA	Sets default input radix
70	REFRESH	RF	Updates windows related to memory
71	REGISTER_DISPLAY	RD	Displays CPU register values
72	REGISTER_SET	RS	Sets CPU register contents
73	REMOVE_FILE	REM	Deletes the specified file from the current project
74	RESET	RE	Resets CPU
75	SAVE_SESSION	SE	Saves the current session
76	SLEEP	-	Delays command execution
77	STEP	ST	Steps program (by instructions or source lines)
78	STEP_MODE	SM	Sets the step mode
79	STEP_OUT	SP	Steps out of the current function
80	STEP_OVER	SO	Steps program, not stepping into functions
81	STEP_RATE	SR	Sets or displays rate of stepping
82	SUBMIT	SU	Executes a command file
83	SYMBOL_ADD	SA	Defines a symbol
84	SYMBOL_CLEAR	SC	Deletes a symbol
85	SYMBOL_LOAD	SL	Loads a symbol information file
86	SYMBOL_SAVE	SS	Saves a symbol information file
87	SYMBOL_VIEW	SV	Displays symbols
88	STATUS	STS	The content of the [Platform] sheet in the [Status] window is displayed.
89	SAVE_WORKSPACE	SW	Saves the current workspace
90	TCL	-	Enables or disables the TCL
91	TEST_EMULATOR	TEM	Tests the on-chip flash memory area
92	TIMER	TI	Sets or displays the timer resolution
93	TOOL_INFORMATION	TO	Outputs information on the currently registered tool to a file
94	TRACE	TR	Displays trace information
95	TRACE_ACQUISITION	TA	Sets or displays trace acquisition parameters
96	TRACE_ACQUISITIONn	TAn	Sets PtoP point and each channel for trace acquisition conditions
97	TRACE_ACQUISITION_CLEAR	TAC	Deletes trace acquisition parameters
98	TRACE_BINARY_COMPARE	TBC	Compares a trace binary file with the current trace information
99	TRACE_BINARY_SAVE	TBV	Outputs trace information into a binary file
100	TRACE_FILTER	TF	Filters trace information
101	TRACE_SAVE	TV	Outputs trace information into a file
102	TRACE_STATISTIC	TST	Analyzes statistic information
103	UPDATE_ALL_DEPENDENCIES	UD	Updates dependencies of the current project
104	USER_SIGNALS	US	Enables or disables the user signal information

Table B.1 High-performance Embedded Workshop Commands (cont)

No.	Command Name	Abbreviation	Function
105	WATCH_ADD	WA	Adds a watch item
106	WATCH_AUTO_UPDATE	WU	Selects or cancels automatic update of watch items
107	WATCH_DELETE	WD	Deletes a watch item
108	WATCH_DISPLAY	WI	Displays the contents of the Watch window
109	WATCH_EDIT	WE	Edits the value of a watch item
110	WATCH_EXPAND	WX	Expands or collapses a watch item
111	WATCH_RADIX	WR	Changes the radix of a watch item to be displayed
112	WATCH_SAVE	WS	Saves the contents of the Watch window to a file

For the syntax of each command, refer to the online help.

**SH7058 E6000H Emulator HS7058EPH62H
SH7058S, SH7059 E6000H Emulator HS7059EPH62H
User's Manual**

Publication Date: Rev.1.00, June 30, 2009

Published by: Sales Strategic Planning Div.
Renesas Technology Corp.

Edited by: Customer Support Department
Global Strategic Communication Div.
Renesas Solutions Corp.

Renesas Technology Corp. Sales Strategic Planning Div. Nippon Bldg., 2-6-2, Ohte-machi, Chiyoda-ku, Tokyo 100-0004, Japan



RENESAS SALES OFFICES

<http://www.renesas.com>

Refer to "<http://www.renesas.com/en/network>" for the latest and detailed information.

Renesas Technology America, Inc.

450 Holger Way, San Jose, CA 95134-1368, U.S.A
Tel: <1> (408) 382-7500, Fax: <1> (408) 382-7501

Renesas Technology Europe Limited

Dukes Meadow, Millboard Road, Bourne End, Buckinghamshire, SL8 5FH, U.K.
Tel: <44> (1628) 585-100, Fax: <44> (1628) 585-900

Renesas Technology (Shanghai) Co., Ltd.

Unit 204, 205, AZIACenter, No.1233 Lujiazui Ring Rd, Pudong District, Shanghai, China 200120
Tel: <86> (21) 5877-1818, Fax: <86> (21) 6887-7858/7898

Renesas Technology Hong Kong Ltd.

7th Floor, North Tower, World Finance Centre, Harbour City, Canton Road, Tsimshatsui, Kowloon, Hong Kong
Tel: <852> 2265-6688, Fax: <852> 2377-3473

Renesas Technology Taiwan Co., Ltd.

10th Floor, No.99, Fushing North Road, Taipei, Taiwan
Tel: <886> (2) 2715-2888, Fax: <886> (2) 3518-3399

Renesas Technology Singapore Pte. Ltd.

1 Harbour Front Avenue, #06-10, Keppel Bay Tower, Singapore 098632
Tel: <65> 6213-0200, Fax: <65> 6278-8001

Renesas Technology Korea Co., Ltd.

Kukje Center Bldg. 18th Fl., 191, 2-ka, Hangang-ro, Yongsan-ku, Seoul 140-702, Korea
Tel: <82> (2) 796-3115, Fax: <82> (2) 796-2145

Renesas Technology Malaysia Sdn. Bhd

Unit 906, Block B, Menara Amcorp, Amcorp Trade Centre, No.18, Jln Persiaran Barat, 46050 Petaling Jaya, Selangor Darul Ehsan, Malaysia
Tel: <603> 7955-9390, Fax: <603> 7955-9510

SH7058 E6000H Emulator HS7058EPH62H
SH7058S, SH7059 E6000H Emulator
HS7059EPH62H
User's Manual



Renesas Technology Corp.

2-6-2, Ote-machi, Chiyoda-ku, Tokyo, 100-0004, Japan