

3-Pin μ P Voltage Supervisor

FEATURES

- Ultra Low Supply Current 1 μ A(typ.)
- Guaranteed Reset Valid to VCC=0.9V
- Available in three Output Types: Open Drain Active Low (PCS809N), Push-Pull Active Low (PCS809), Push-Pull Active High (PCS810)
- 140ms Min. Power-On Reset Pulse Width
- Internally Fixed Threshold 2.3V, 2.6V, 2.9V, 3.1V, 4.0V, 4.4V, and 4.6V
- Tight Voltage Threshold Tolerance: 1.5%
- Low profile Package: SOT-23-3

APPLICATIONS

- Notebook Computers
- Digital Still Cameras
- PDAs
- Critical Microprocessor Monitoring

RESET THRESHOLD	
Suffix	Voltage(V)
L	4.6
M	4.4
J	4.0
T	3.1
S	2.9
R	2.6
P	2.3

DESCRIPTION

PCS809/PCS810 are low-power microprocessor (μ P) supervisory circuits used to monitor power supplies in μ P and digital systems. They provide applications with benefits of circuit reliability and low cost by eliminating external components.

These devices perform as valid singles in applications with VCC ranging from 6.0V down to 0.9V. The reset signal lasts for a minimum period of 140ms whenever VCC supply voltage falls below preset threshold. Both PCS809 and PCS810 were designed with a reset comparator to help identify invalid signals, which last less than 140ms. The only difference between them is that they have an active-low RESET output and active-high RESET output, respectively.

Low supply current (1 μ A) makes PCS809/PCS810 ideal for portable equipment. The devices are available in 3-SOT-23 package

Typical Operating Circuit

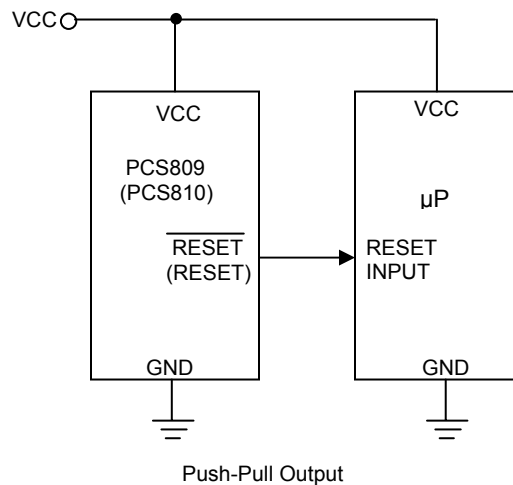

rev 0.2

Pin Diagram

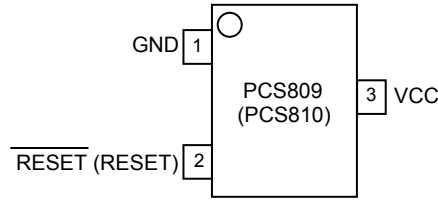

Pin Description

Pin#		Pin Name	Description
PCS809	PCS810		
1	1	GND	Ground.
2	-	$\overline{\text{RESET}}$	$\overline{\text{RESET}}$ is asserted LOW if V_{CC} falls below V_{TH} . $\overline{\text{RESET}}$ remains LOW for atleast 140ms (T_{RST}) once V_{CC} exceeds the Threshold. In addition, $\overline{\text{RESET}}$ is active LOW
-	2	RESET	RESET is asserted HIGH if V_{CC} falls below V_{TH} . RESET remains HIGH for atleast 140ms (T_{RST}) once V_{CC} exceeds the threshold. In addition, RESET is active HIGH
3	3	VCC	Power supply input voltage (3.0V, 3.3V, 5.0V)

Block Diagrams

N-ch Open-Drain Type

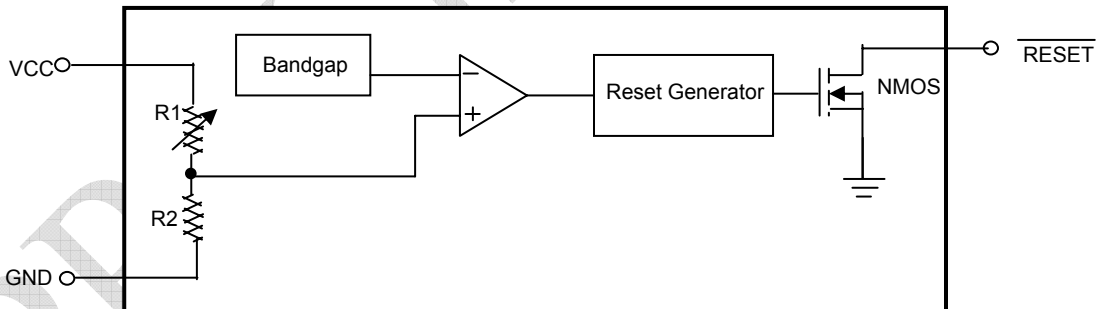

Push-Pull Type

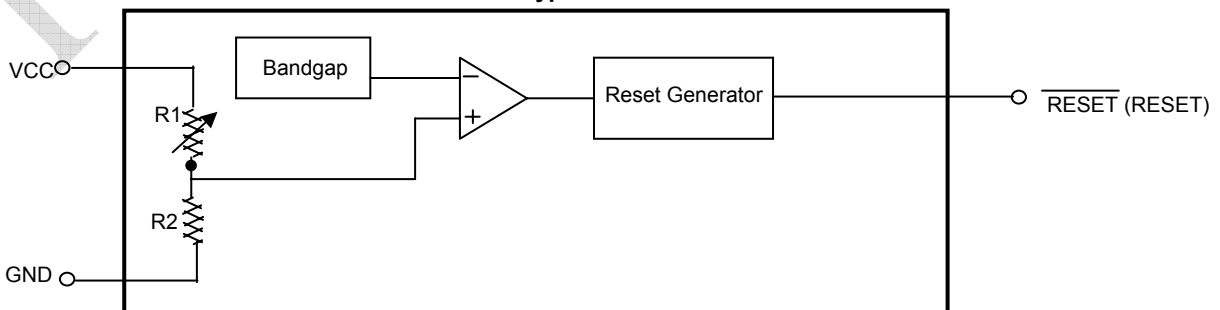

Detailed Description

RESET OUTPUT

μ P will be activated at a valid reset state. These μ P supervisory circuits assert reset to prevent code execution errors during power-up, power-down, or brownout conditions.

$\overline{\text{RESET}}$ is guaranteed to be a logic low for $V_{\text{TH}} > V_{\text{CC}} > 0.9\text{V}$. Once VCC exceeds the reset threshold, an internal timer keeps $\overline{\text{RESET}}$ low for the reset timeout period; after this interval, $\overline{\text{RESET}}$ goes high.

If a brownout condition occurs (VCC drops below the reset threshold), $\overline{\text{RESET}}$ goes low. Any time VCC goes below the reset threshold, the internal timer resets to zero, and $\overline{\text{RESET}}$ goes low. The internal timer is activated after VCC

returns above the reset threshold, and $\overline{\text{RESET}}$ remains low for the reset timeout period.

BENEFITS OF HIGHLY ACCURATE RESET THRESHOLD

PCS809/810 with specified voltage as $5\text{V} \pm 10\%$ or $3\text{V} \pm 10\%$ are ideal for systems using a $5\text{V} \pm 5\%$ or $3\text{V} \pm 5\%$ power supply. The reset is guaranteed to assert after the power supply falls out of regulation, but before power drops below the minimum specified operating voltage range of the system ICs. The pre-trimmed thresholds are reducing the range over which an undesirable reset may occur.

Application Information

NEGATIVE-GOING VCC TRANSIENTS

In addition to issuing a reset to the μ P during power-up, power-down, and brownout conditions, PCS809 series are relatively resistant to short-duration negative-going VCC transient.

ENSURING A VALID RESET OUTPUT DOWN TO VCC=0

When VCC falls below 0.9V, PCS809 $\overline{\text{RESET}}$ output no longer sinks current; it becomes an open circuit. In this case, high-impedance CMOS logic inputs connecting to $\overline{\text{RESET}}$ can drift to undetermined voltages. Therefore, PCS809/810 with CMOS is perfect for most applications of

VCC below 0.9V. However in applications where $\overline{\text{RESET}}$ must be valid down to 0V, adding a pull-down resistor to $\overline{\text{RESET}}$ causes any leakage currents to flow to ground, holding $\overline{\text{RESET}}$ low.

INTERFACING TO μ P WITH BIDIRECTIONAL RESET PINS

The $\overline{\text{RESET}}$ output on the PCS809 is open drain, this device interfaces easily with μ Ps that have bidirectional reset pins. Connecting the μ P supervisor's $\overline{\text{RESET}}$ output directly to the microcontroller's $\overline{\text{RESET}}$ pin with a single pull-up resistor allows either device to assert reset.

Absolute Maximum Rating

Parameter	Min	Max	Unit
VCC	0.3	6.5	V
RESET, $\overline{\text{RESET}}$	0.3	V _{CC} +0.3	V
Input Current (VCC)		20	mA
Output Current (RESET or $\overline{\text{RESET}}$)		20	mA
Continuous Power Dissipation (T _A =+70°C)		320	mW
Operating Junction Temperature Range	-40	+85	°C
Junction Temperature		125	°C
Storage Temperature Range	-65	150	°C
Lead Temperature (Soldering) 10 sec		260	°C

Test Circuit

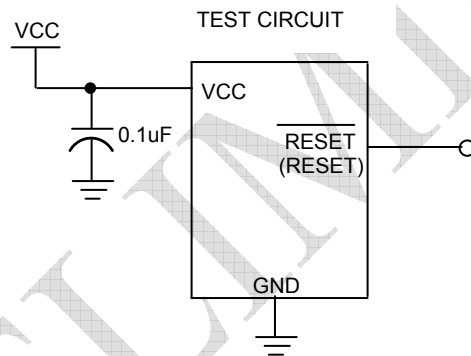

rev 0.2

Electrical Characteristics:

(Typical values are at $T_A=+25^\circ\text{C}$ unless otherwise specified.) (Note1)

Parameter	Symbol	Test Conditions	Min	Typ	Max	Unit	
Operating Voltage	VCC		0.9		6	V	
Supply Current	I _{CC}	VCC= V _{TH} +0.1V		1	3	μA	
RESET threshold	V _{TH}	P device	T _A =+25°C	2.265	2.3	2.335	V
			T _A =-40°C to +85°C	2.254		2.346	
		R device	T _A =+25°C	2.561	2.6	2.639	
			T _A =-40°C to +85°C	2.548		2.652	
		S device	T _A =+25°C	2.857	2.9	2.944	
			T _A =-40°C to +85°C	2.842		2.958	
		T device	T _A =+25°C	3.054	3.1	3.147	
			T _A =-40°C to +85°C	3.038		3.162	
		J device	T _A =+25°C	3.940	4.0	4.060	
			T _A =-40°C to +85°C	3.920		4.080	
		M device	T _A =+25°C	4.334	4.4	4.466	
			T _A =-40°C to +85°C	4.312		4.488	
		L device	T _A =+25°C	4.531	4.6	4.669	
			T _A =-40°C to +85°C	4.508		4.692	
VCC to Reset Delay	T _{RD}	VCC=V _{TH} to (V _{TH} -0.1V), V _{TH} =3.1V		20		μS	
Reset Active Timeout Period	T _{RP}	VCC=V _{TH} (MAX)	T _A =+25°C	140	230	560	mS
			T _A =-40°C to +85°C	100		1030	
RESET output Voltage	V _{OH}	VCC = V _{TH} +0.1V, I _{SOURCE} =1mA	0.8VCC			V	
	V _{OL}	VCC = V _{TH} -0.1V, I _{SINK} =1mA			0.2VCC		
RESET output Voltage	V _{OH}	VCC = V _{TH} +0.1V, I _{SOURCE} =1mA	0.8VCC				
	V _{OL}	VCC = V _{TH} -0.1V, I _{SINK} =1mA			0.2VCC		

Note1: Specifications are production tested at $T_A=25^\circ\text{C}$. Specifications over the -40°C to 85°C operating temperature range are assured by design, characterization and correlation with Statistical Quality Controls (SQC).

Note 2: RESET output is for PCS809: RESET output for PCS810.

Ordering Information

Part #	Threshold Voltage	Temperature Range	Package	Top Marking
PCS809 Push-Pull type				
PCS809LIURF	4.6	-40°C to +85°C	3-SOT-23	RA46P
PCS809MIURF	4.4	-40°C to +85°C	3-SOT-23	RA44P
PCS809JIURF	4.0	-40°C to +85°C	3-SOT-23	RA40P
PCS809TIURF	3.1	-40°C to +85°C	3-SOT-23	RA31P
PCS809SIURF	2.9	-40°C to +85°C	3-SOT-23	RA29P
PCS809RIURF	2.6	-40°C to +85°C	3-SOT-23	RA26P
PCS809PIURF	2.3	-40°C to +85°C	3-SOT-23	RA23P
PCS809 N Open- Drain type				
PCS809NLIURF	4.6	-40°C to +85°C	3-SOT-23	RB46P
PCS809NMIURF	4.4	-40°C to +85°C	3-SOT-23	RB44P
PCS809NJIURF	4.0	-40°C to +85°C	3-SOT-23	RB40P
PCS809NTIURF	3.1	-40°C to +85°C	3-SOT-23	RB31P
PCS809NSIURF	2.9	-40°C to +85°C	3-SOT-23	RB29P
PCS809NRIURF	2.6	-40°C to +85°C	3-SOT-23	RB26P
PCS809NPIURF	2.3	-40°C to +85°C	3-SOT-23	RB23P
PCS810 ACTIVE HIGH RESET				
PCS810LIURF	4.6	-40°C to +85°C	3-SOT-23	RD46P
PCS810MIURF	4.4	-40°C to +85°C	3-SOT-23	RD44P
PCS810JIURF	4.0	-40°C to +85°C	3-SOT-23	RD40P
PCS810TIURF	3.1	-40°C to +85°C	3-SOT-23	RD31P
PCS810SIURF	2.9	-40°C to +85°C	3-SOT-23	RD29P
PCS810RIURF	2.6	-40°C to +85°C	3-SOT-23	RD26P
PCS810PIURF	2.3	-40°C to +85°C	3-SOT-23	RD23P

Note:

For parts to be packed in tape and reel, add "T" at the end of the part number

PulseCore Semiconductor parts are RoHS Compliant. All parts are lead free by default.

rev 0.2

Package Information: 3- SOT23 Package

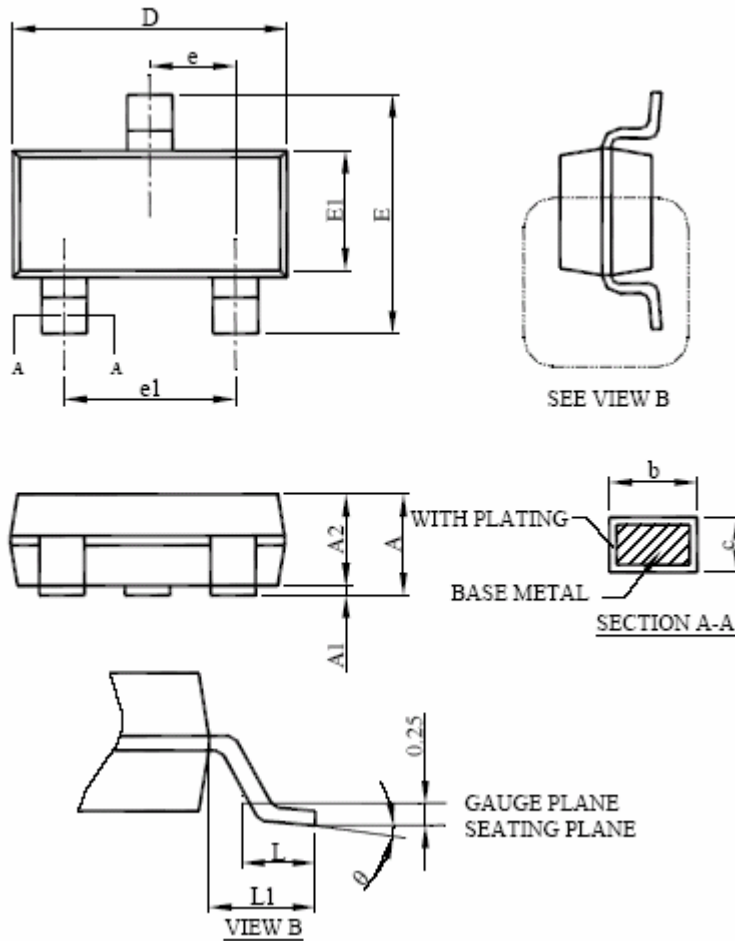

Symbol	Dimensions			
	Inches		Millimeters	
	Min	Max	Min	Max
A	0.035	0.057	0.95	1.45
A1	0.00	0.006	0.05	0.15
A2	0.035	0.051	0.90	1.30
b	0.009	0.015	0.30	0.50
c	0.003	0.009	0.08	0.22
D	0.111	0.117	2.80	3.00
E	0.106	0.114	2.60	3.00
E1	0.060	0.066	1.50	1.70
L	0.014	0.022	0.30	0.60
L1	0.023 REF		0.60 REF	
e	0.0256 BSC		0.95 BSC	
e1	0.0768 BSC		1.90 BSC	
θ	0°	8°	0°	8°



PulseCore Semiconductor Corporation
1715 S. Bascom Ave Suite 200
Campbell, CA 95008
Tel: 408-879-9077
Fax: 408-879-9018
www.pulsecoresemi.com

Copyright © PulseCore Semiconductor
All Rights Reserved
Part Number: PCS809/810
Document Version: 0.2

Note: This product utilizes US Patent # 6,646,463 Impedance Emulator Patent issued PulseCore Semiconductor, dated 11-11-2003

© Copyright 2007 PulseCore Semiconductor Corporation. All rights reserved. Our logo and name are trademarks or registered trademarks of PulseCore Semiconductor. All other brand and product names may be the trademarks of their respective companies. PulseCore reserves the right to make changes to this document and its products at any time without notice. PulseCore assumes no responsibility for any errors that may appear in this document. The data contained herein represents PulseCore's best data and/or estimates at the time of issuance. PulseCore reserves the right to change or correct this data at any time, without notice. If the product described herein is under development, significant changes to these specifications are possible. The information in this product data sheet is intended to be general descriptive information for potential customers and users, and is not intended to operate as, or provide, any guarantee or warranty to any user or customer. PulseCore does not assume any responsibility or liability arising out of the application or use of any product described herein, and disclaims any express or implied warranties related to the sale and/or use of PulseCore products including liability or warranties related to fitness for a particular purpose, merchantability, or infringement of any intellectual property rights, except as express agreed to in PulseCore's Terms and Conditions of Sale (which are available from PulseCore). All sales of PulseCore products are made exclusively according to PulseCore's Terms and Conditions of Sale. The purchase of products from PulseCore does not convey a license under any patent rights, copyrights; mask works rights, trademarks, or any other intellectual property rights of PulseCore or third parties. PulseCore does not authorize its products for use as critical components in life-supporting systems where a malfunction or failure may reasonably be expected to result in significant injury to the user, and the inclusion of PulseCore products in such life-supporting systems implies that the manufacturer assumes all risk of such use and agrees to indemnify PulseCore against all claims arising from such use.