

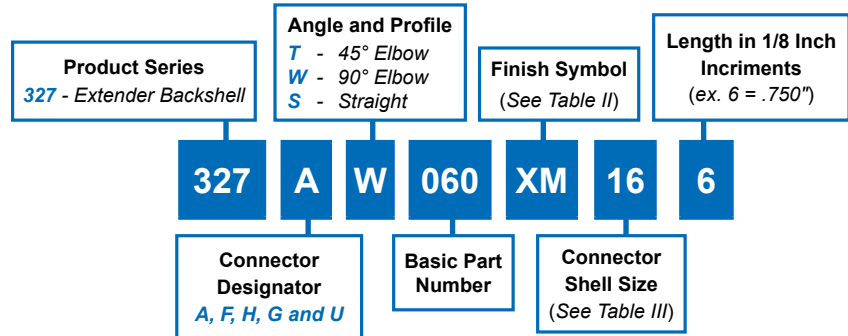

327-060 Extender Backshell with Self-Locking Rotatable Coupling

A

CONNECTOR DESIGNATOR:	
A	MIL-DTL-5015, -26482 Series II, and -83723 Series I and III
F	MIL-DTL-38999 Series I, II
H	MIL-DTL-38999 Series III and IV
G	MIL-DTL-28840
U	DG123 and DG123A
SELF-LOCKING	
ROTATABLE COUPLING	
STANDARD PROFILE	



Note: See Table I in Intro for Front-End Dimensional Details

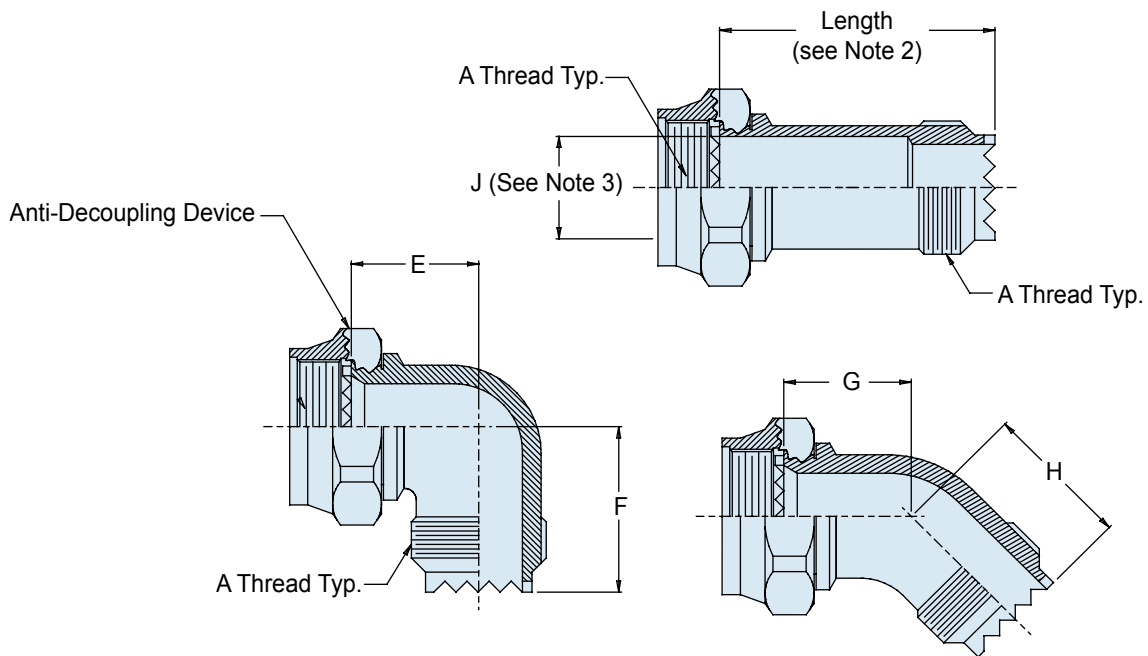

APPLICATION NOTES

1. Metric dimensions (mm) are in parentheses and are for reference only.
2. Available length, straight configuration only, 6 = .750 (19.1), 8 = 1.00 (25.4), consult factory for additional length. Omit length designator for angular functions.
3. J Diameter applicable to connector Code H, straight configuration only.
4. Coupling nut supplied unplated.
5. See Table I in Intro for front-end dimensional details.

327-060
Extender Backshell
 with Self-Locking Rotatable Coupling



TABLE II: FINISH	
Symbol	Finish Description
XM	2000 Hour Corrosion Resistant Electroless Nickel
XMT	2000 Hour Corrosion Resistant Ni-PTFE, Nickel-Fluorocarbon Polymer. <i>1000 Hour Grey™</i>
XO	No Plating - Brown Color (Non-Conductive Finish)
XB	No Plating - Black Color (Non-Conductive Finish)
XW	2000 Hour Corrosion Resistant Cadmium/Olive Drab over Electroless Nickel

TABLE III: CONNECTOR SHELL SIZE ORDER NUMBER									
Shell Size For Connector Designator		E		F		G		H	
A, F	H	Max		Max		Max		Max	
08	09	.74	(18.8)	1.00	(25.4)	.78	(19.8)	.89	(22.6)
10	11	.80	(20.3)	1.06	(26.9)	.81	(20.6)	.92	(23.4)
12	13	.86	(21.8)	1.12	(28.4)	.81	(20.6)	.94	(23.9)
14	15	.93	(23.6)	1.19	(30.2)	.82	(20.8)	.97	(24.6)
16	17	.99	(25.1)	1.25	(31.8)	.84	(21.3)	.99	(25.1)
18	19	1.05	(26.7)	1.31	(33.3)	.85	(21.6)	1.00	(25.4)
20	21	1.12	(28.4)	1.38	(35.1)	.88	(22.4)	1.03	(26.2)
22	23	1.18	(30.0)	1.44	(36.6)	.92	(23.4)	1.07	(27.2)
24	25	1.24	(31.5)	1.50	(38.1)	.97	(24.6)	1.08	(27.4)