

360-015 Composite Non-Environmental Backshell with Self-Locking Rotatable Coupling and Qwik-Clamp Strain-Relief

A

CONNECTOR DESIGNATOR:	
A	MIL-DTL-5015, -26482 Series II, and -83723 Series I and III
F	MIL-DTL-38999 Series I, II
L	MIL-DTL-38999 Series 1.5 (JN1003)
H	MIL-DTL-38999 Series III and IV
G	MIL-DTL-28840
U	DG123 and DG123A
SELF-LOCKING	
ROTATABLE COUPLING	
STANDARD PROFILE	

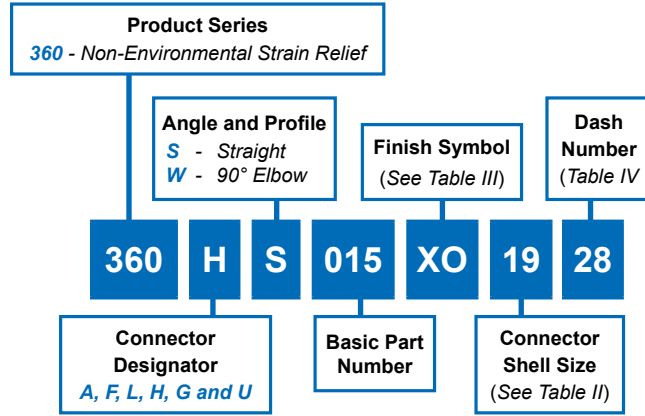

US PATENT 5211576

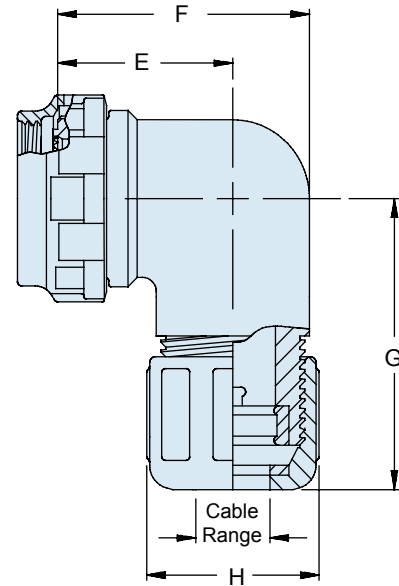
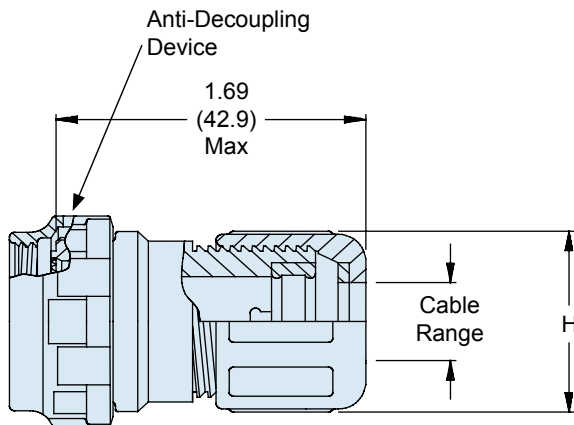

NOTES

1. Coupling nut supplied unplated.
2. See Table I in Intro for front-end dimensional details.
3. Metric dimensions (mm) are in parentheses and are for reference only

360-015
Composite Non-Environmental Backshell
with Self-Locking Rotatable Coupling
and Qwik-Clamp Strain-Relief



TABLE II: CONNECTOR SHELL SIZE ORDER NUMBER

Shell Size For		E		F		G		Max Entry Dash No. *
A, F/L, & H	G & U	± .06	(1.5)	± .09	(2.3)	± .09	(2.3)	
08, 09	---	.69	(17.5)	.88	(22.4)	1.19	(30.2)	08
03, 10, 11	08	.75	(19.1)	1.00	(25.4)	1.25	(31.8)	12
12, 13	10, 11	.81	(20.6)	1.13	(28.7)	1.31	(33.3)	16
14, 15	12, 13	.88	(22.4)	1.31	(33.3)	1.38	(35.1)	20
16, 17	14, 15	.94	(23.9)	1.38	(35.1)	1.44	(36.6)	24
18, 19	16, 17	.97	(24.6)	1.44	(36.6)	1.47	(37.3)	28
20, 21	18, 19	1.06	(26.9)	1.63	(41.4)	1.56	(39.6)	32
22, 23	20	1.13	(28.7)	1.75	(44.5)	1.63	(41.4)	36
24, 25, 61	22, 23	1.19	(30.2)	1.88	(47.8)	1.69	(42.9)	40
28	24, 25	1.34	(34.0)	2.13	(54.1)	1.78	(45.2)	44

* Consult factory for additional entry sizes available.

TABLE III: FINISH

Symbol	Finish Description
XB	No Plating - Black Color
XM	2000 Hour Corrosion Resistant Electroless Nickel
XMT	2000 Hour Corrosion Resistant Ni-PTFE, Nickel-Fluorocarbon Polymer. <i>1000 Hour Grey™</i>
XO	No Plating - Brown Color
XW	2000 Hour Corrosion Resistant Cadmium/Olive Drab over Electroless Nickel

TABLE IV: CABLE ENTRY

Dash No	H (Max)		Saddle Kit *		Cable Range			
	±.06	(1.5)	Minimum	Minimum	Minimum	Maximum	Maximum	Maximum
08	.72	(18.3)	---	---	.10	(2.5)	.25	(6.4)
12	.91	(23.1)	.10	(2.5)	.20	(5.1)	.38	(9.7)
16	1.09	(27.7)	.10	(2.5)	.33	(8.4)	.50	(12.7)
20	1.22	(31.0)	.20	(5.1)	.45	(11.4)	.63	(15.9)
24	1.34	(34.0)	.33	(8.4)	.52	(13.2)	.75	(19.1)
28	1.53	(38.9)	.45	(11.4)	.64	(16.3)	.88	(22.2)
32	1.72	(43.7)	.52	(13.2)	.77	(19.6)	1.00	(25.4)
36	1.85	(47.0)	.64	(16.3)	.86	(21.8)	1.13	(28.6)
40	1.97	(50.0)	.77	(19.6)	.98	(24.9)	1.25	(31.8)
44	2.09	(53.1)	.86	(21.8)	1.13	(28.6)	1.38	(34.9)

* Consult factory for availability of special saddle bar kit to reduce minimum clamp range.