

EGC10DH THRU EGC10MH

● **FEATURES**

- * Halogen-free type
- * Lead free product, compliance to RoHS
- * GPRC (Glass passivated rectifier chip) inside
- * Glass passivated cavity-free junction
- * Lead less chip form, no lead damage
- * Low power loss , High efficiency
- * High current capability
- * Plastic package has Underwriters Laboratory Flammability Classification 94V-0

● **APPLICATION**

- * General purpose rectification
- * Surge absorption

● **MECHANICAL DATA**

Case : Packed with FRP substrate and epoxy underfilled
Terminals : Pure Tin plated (Lead-Free), solderable per MIL-STD-750, Method 2026.
Polarity : Cathode Band, Laser marking
Weight : 0.02 gram

● **PACKING**

- * 3,000 pieces per 7" (178mm ± 2mm) reel
- * 4 reels per box
- * 6 boxes per carton

● **OUTLINE DIMENSIONS**

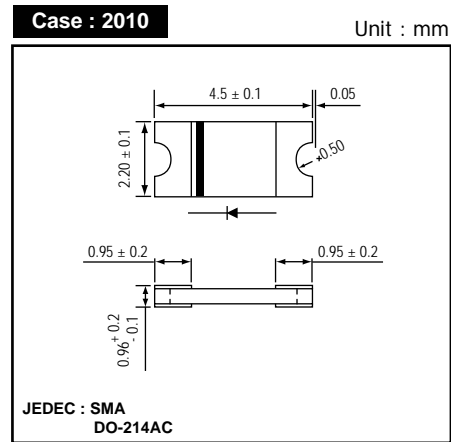

● **MARKING**

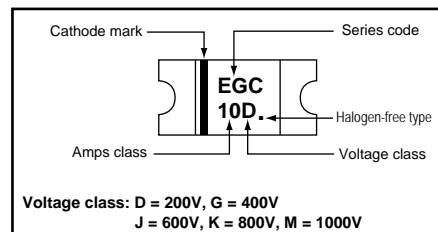

Absolute Maximum Ratings (Ta = 25 °C)

ITEM	Symbol	Conditions	EGC10					Unit
			DH	GH	JH	KH	MH	
Repetitive peak reverse voltage	VRRM		200	400	600	800	1000	V
Average forward current	IF(AV)		1.0					A
Peak forward surge current	IFSM	8.3ms single half sine-wave	30		25			A
Reverse recovery time	Trr	IF = 0.5A, IR = 1.0A, Irr = 0.25A	50		75			nS
Operating storage temperature Range	Tj,TSTG		-65 to +175					°C

ITEM	Symbol	Conditions	Type	Min.	Typ.	Max.	Unit
Forward voltage	VF	IF = 1.0A	EGC10DH	-	0.95	1.00	V
			EGC10GH	-	1.05	1.25	
			EGC10JH	-	1.45	1.70	
			EGC10KH	-	1.45	1.70	
			EGC10MH	-	1.45	1.70	
Repetitive peak reverse current	IRRM	VR = Max. VRRM , Ta = 25 °C		-	0.10	5	uA
Junction capacitance	Cj	VR = 4V, f = 1.0 MHz		-	9	-	pF
Thermal resistance	Rth(JA)	Junction to ambient (NOTE)		-	65	-	°C/W
	Rth(JL)	Junction to lead (NOTE)		-	14	-	

NOTES : Thermal resistance from junction to ambient and from junction to lead P.C.B. mounted on 0.2 x 0.2" (5.0 x 5.0mm) copper pad areas.

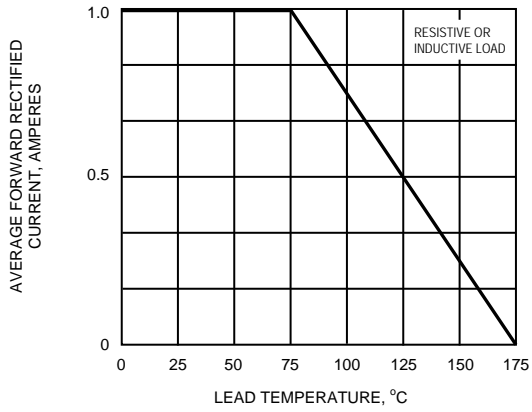
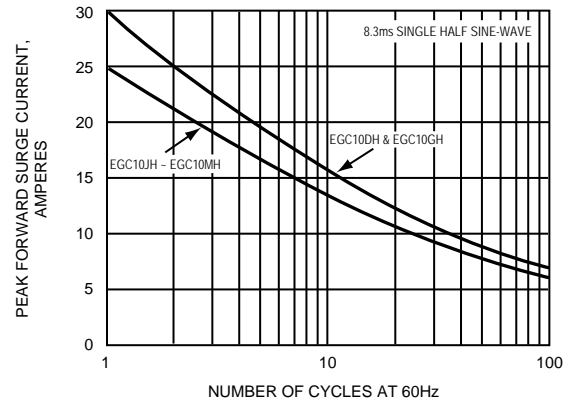
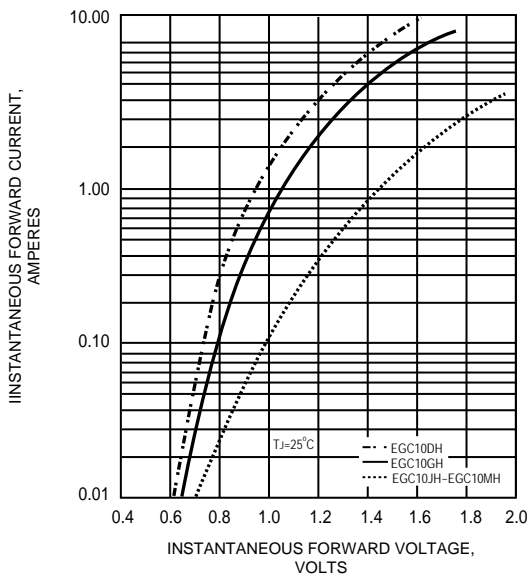
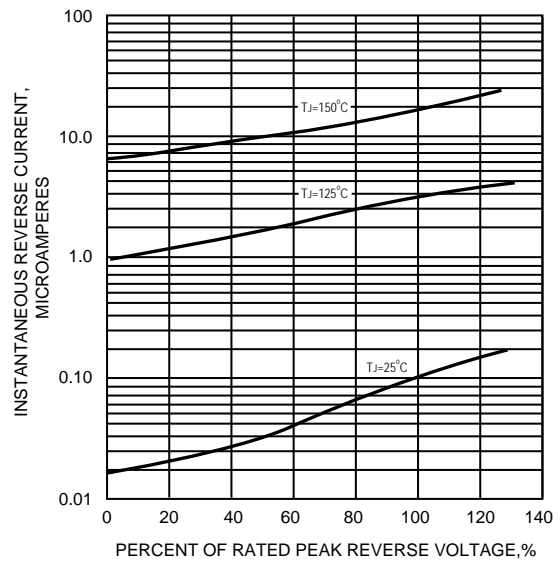
FIG.1 - TYPICAL FORWARD CURRENT DERATING CURVE

FIG.2 - MAXIMUM NON-REPETITIVE PEAK FORWARD SURGE CURRENT

FIG.3 - TYPICAL INSTANTANEOUS FORWARD CHARACTERISTICS

FIG.4 - TYPICAL REVERSE CHARACTERISTICS PER BRIDGE ELEMENT

FIG.5 - TYPICAL JUNCTION CAPACITANCE
