

850 nm 10 G TOSA

PL-xxD-00-S40-Cx

**Key Features**

- Data rates up to 10 Gbps
- -10 °C to 85 °C operation
- Optical power monitor with excellent tracking
- Multiple pinout options available
- VCSEL TO-can aligned to LC or SC optical housing
- Optional flex attach to PCBA

Benefits

- Industry standard housing dimensions
- Very high reliability
 - Low FIT
 - High MTBF
- Excellent performance over extended operational temperatures
- Modulation performance verification

The JDSU 850 nm 10 Gbps connectorized TOSA product (Transmit Optical Sub-Assembly) is designed for high-speed data communication applications in 10 Gbps transceiver modules. The product utilizes a high performance, high reliability VCSEL integrated in a custom hermetically sealed TO package aligned to a precision LC or SC housing. The device is configured for differential drive and a controlled impedance flex circuit is available for optimum performance. Each unit receives JDSU's proprietary burn-in and stabilization process to insure a low failure rate and long life expectancy while providing continuously consistent performance.

The PL-xxD-00-S40-Cx converts an electrical signal into optical power at data rates up to 10 Gbps and it is designed for performance over extended operating temperature and power conditions with high reliability. It is perfectly suited for 50/125 μm multimode fiber. Each part is electro-optically tested to exacting standards.

2

TOSA with Flex Dimensions (SC)

UNITS: MM

.X = ± 0.2
 .XX = ± 0.10
 .XXX = ± 0.050

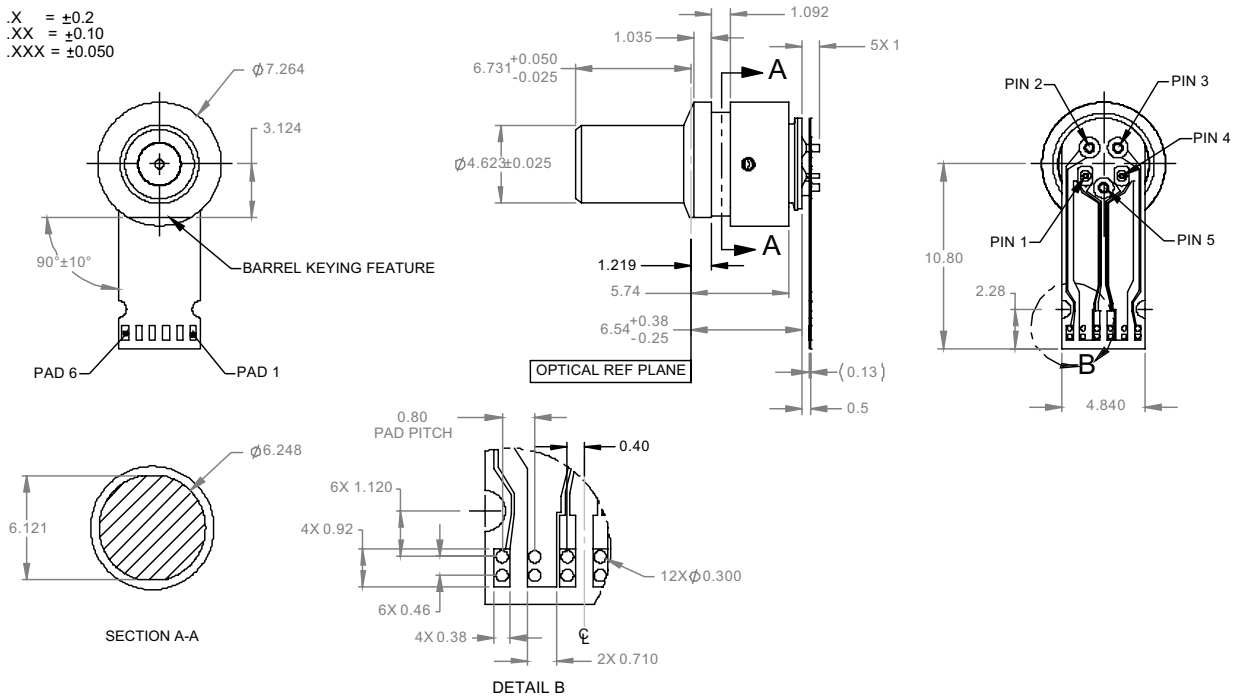

Pinout

PL-FxC-00-S40-C4

(5-lead TOSA, Anode drive, with flex)

Pad	Symbol	Function
1	A _{PD}	Monitor Anode
2	GND	Case/GND
3	A _{LD}	VCSEL Anode
4	NC	Not Connected
5	GND	Case/GND
6	K _{PD}	Monitor Cathode

PL-FxD-00-S40-C5

(5-lead TOSA, Differential drive, with flex)

Pad	Symbol	Function
1	K _{PD}	Monitor Cathode
2	GND	Case/ GND
3	A _{LD}	VCSEL Anode
4	K _{LD}	VCSEL Cathode
5	GND	Case/GND
6	A _{PD}	Monitor Anode

PL-FxA-00-S40-C6

(5-lead-TOSA, Cathode drive, with flex)

Pad	Symbol	Function
1	K _{PD} , A _{LD}	Vcc, Monitor Cathode, VCSEL Anode
2	GND	Case/GND
3	K _{LD}	VCSEL Cathode
4	NC	Not Connected
5	GND	Case/GND
6	A _{PD}	Monitor Anode

3

TOSA with Flex Dimensions (LC)

UNITS: MM

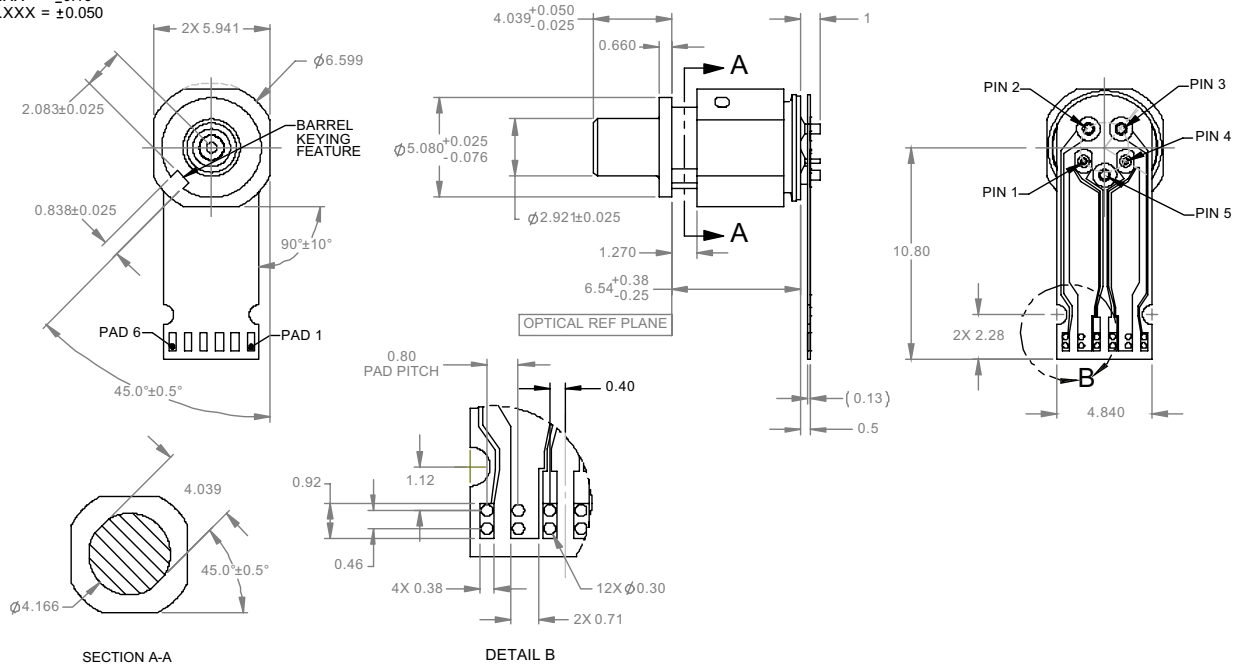
.X = ±0.2
.XX = ±0.10
.XXX = ±0.050

Pinout

PL-FxC-00-S40-C4**(5-lead TOSA, Anode drive, with flex)**

Pad	Symbol	Function
1	A _{PD}	Monitor Anode
2	GND	Case/GND
3	A _{LD}	VCSEL Anode
4	NC	Not Connected
5	GND	Case/GND
6	K _{PD}	Monitor Cathode

PL-FxD-00-S40-C5**(5-lead TOSA, Differential drive, with flex)**

Pad	Symbol	Function
1	K _{PD}	Monitor Cathode
2	GND	Case/ GND
3	A _{LD}	VCSEL Anode
4	K _{LD}	VCSEL Cathode
5	GND	Case/GND
6	A _{PD}	Monitor Anode

PL-FxA-00-S40-C6**(5-lead-TOSA, Cathode drive, with flex)**

Pad	Symbol	Function
1	K _{PD} , A _{LD}	Vcc, Monitor Cathode, VCSEL Anode
2	GND	Case/GND
3	K _{LD}	VCSEL Cathode
4	NC	Not Connected
5	GND	Case/GND
6	A _{PD}	Monitor Anode

4

5-Lead TOSA without Flex Dimensions (LC)

UNITS: MM
 .X = ± 0.2
 .XX = ± 0.10
 .XXX = ± 0.050

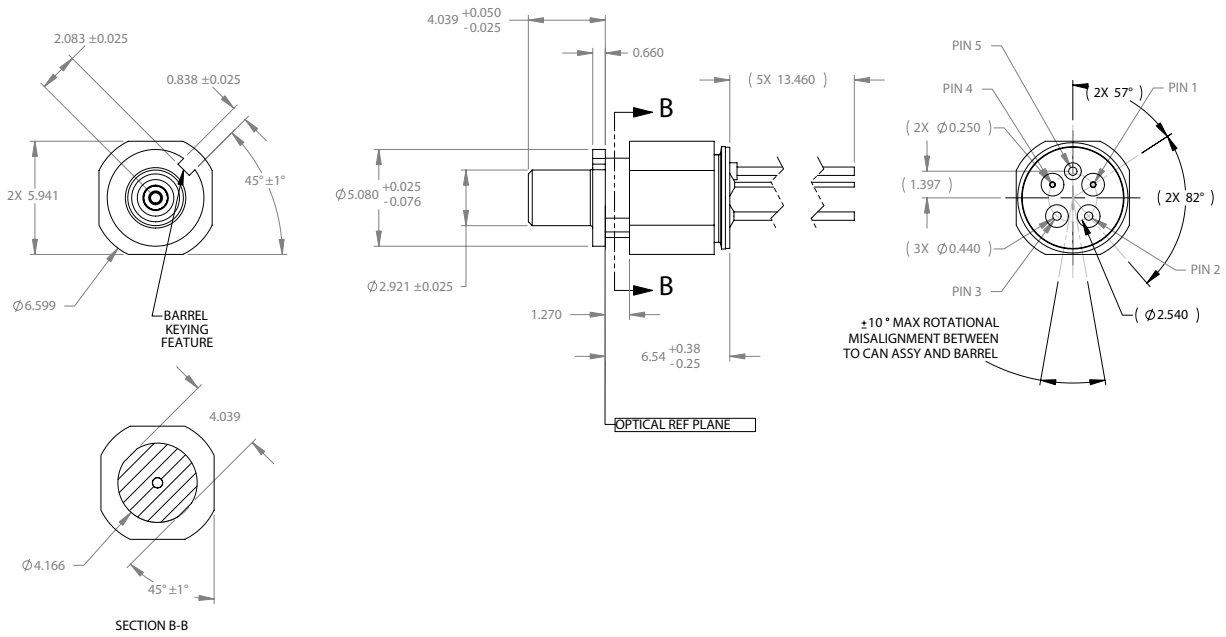

Pinout

PL-SLD-00-S40-C5

(5-lead-TOSA, Differential drive, no flex)

Pad	Symbol	Function
1	A _{LD}	VCSEL Anode
2	K _{PD}	Monitor Cathode
3	A _{PD}	Monitor Anode
4	K _{LD}	VCSEL Cathode
5	GND	Case/GND

Pad	Symbol	Function
1	A _{LD}	VCSEL Anode
2	K _{PD}	Monitor Cathode
3	A _{PD}	Monitor Anode
4	K _{LD}	VCSEL Cathode
5	GND	Case/GND

6

4-Lead TOSA without Flex Dimensions (LC)

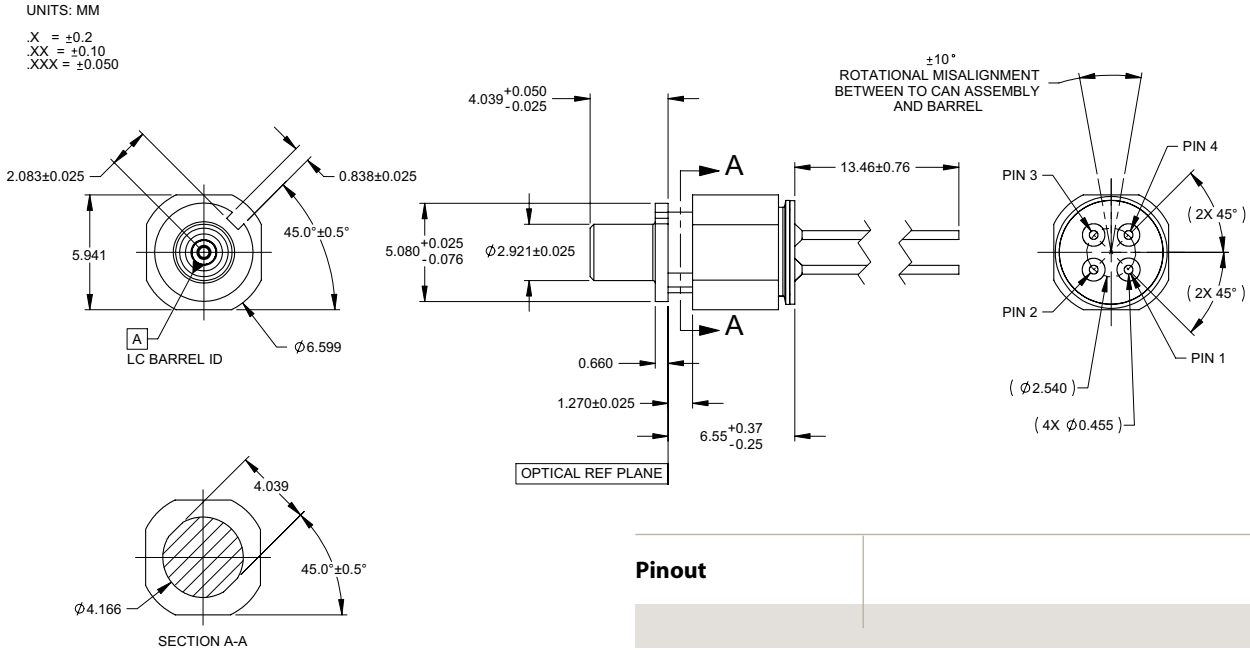

Pinout

PL-SxD-00-S40-C2
(4-lead TOSA, no flex)

Pin	Symbol	Function
1	A _{LD}	VCSEL Anode
2	K _{LD}	VCSEL Cathode
3	A _{PD}	Monitor Anode
4	K _{PD}	Monitor Cathode

Absolute Maximum Ratings

Parameter	Symbol	Ratings	Unit
Storage temperature	T _{st}	-40 to +100	°C
Lead solder temperature	T _s	260 °C for 10 sec. 2 mm from case	
Flex attach temperature	T _F	370 °C for 10 sec.	
Laser forward current at 85 °C ¹	I _f	7	mA
Laser forward current at 70 °C ²	I _f	8	mA
Laser reverse voltage	BV _{R_{LD}}	-2	V
Photodiode forward current	I _{fm}	2	mA
ESD ³		Class 1	

Note:

Conditions exceeding those listed may cause permanent damage to the device. Devices subjected to conditions beyond the limits specified for extended periods of time may adversely affect reliability.

1. Absolute maximum at 85 °C case operating temperature

2. Absolute maximum at 70 °C case operating temperature

3. HBM

7

Shipping Information

Shipped in anti-static stackable trays.

Electro-optical Characteristics

($T_{\text{case}} = 25\text{ }^{\circ}\text{C}$, CW operation unless otherwise stated)

Parameter	Symbol	Test Condition	Min.	Typ.	Max.	Unit
VCSEL						
Peak emission wavelength	λ_p	$P_{\text{out}}=0.5\text{ mW}$	840	850	860	nm
Case operating temperature	T_{op}		-10		85	$^{\circ}\text{C}$
RMS spectral width	$\Delta\lambda$	$P_{\text{out}}=0.5\text{ mW}$; 10.3125Gb/s mod.			0.4	nm
λ_p temp coefficient	$\Delta\lambda_p$			0.06		nm/ $^{\circ}\text{C}$
Relative intensity noise ¹	RIN_{12}	10.3125Gb/s mod.			130	dB/Hz
Rise/Fall time	t_r t_f	$P_{\text{out}}=0.5\text{ mW}$, 10.3125Gb/s, 20-80%, filtered		45 50		psec
Threshold current	I_{th}			1	1.3	mA
I_{th} temperature variation	ΔI_{th}	$T = -10\text{ }^{\circ}\text{C}$ to $85\text{ }^{\circ}\text{C}$		+1.0	+2.0	mA
Laser forward voltage	V_f	$P_{\text{out}}=0.5\text{ mW}$		2.0	2.4	V
Series resistance ²	R_s	$P_{\text{out}}=0.5\text{ mW}$	90	100	110	Ω
Series resistance ³	R_s	$P_{\text{out}}=0.5\text{ mW}$	50	60	75	Ω
Coupling efficiency	efiber			75		%
Slope efficiency ⁴	η	$P_{\text{out}}=0.5\text{ mW}$	0.105		0.175	mW/mA
Slope efficiency temperature variation	$\Delta\eta/\Delta T$			-4000		PPM/ $^{\circ}\text{C}$
Total capacitance @ VCSEL	C_{LD}	6mA bias			0.6	pF
Small signal bandwidth		$P_{\text{out}}=0.5\text{ mW}$	7.75			GHz
Optical return loss					-12	dB
Monitor Photodiode						
Photocurrent	I_{PD}	$P_{\text{out}}=0.5\text{ mW}$ $V_r = 1.5\text{ V}$	0.12		0.6	mA
Monitor current tracking ⁵	ΔI_m	$P_{\text{out}}=0.5\text{ mW}$ $T = -10\text{ }^{\circ}\text{C}$ to $85\text{ }^{\circ}\text{C}$ $V_{\text{rm}} = 1.5\text{ V}$	-0.25		0.25	dB
Monitor dark current	I_{D}	$V_r = 1.5\text{ V}$			500	nA
Monitor capacitance	C_{M}	$V_{\text{rm}} = 1.5\text{ V}$			50	pF

1. Measured according to IEEE802.3 for RIN under Modulation.

2. Applies to PL-SxD-00-S40-C2 and PL-FxD-00-S40-C5

3. Applies to PL-FxC-00-S40-C4 and PL-FxA-00-S40-C6

4. Includes connector repeatability, ferrule concentricity, and diameter (50 μm fiber).

5. For constant monitor current. Does not include the effect of fiber coupling efficiency.

Order Information

For more information on this or other products and their availability, please contact your local JDSU account manager or JDSU directly at 1-800-498-JDSU (5378) in North America and +800-5378-JDSU worldwide or via e-mail at customer.service@jdsu.com.

Sample: PL-SSD-00-S40-C2**10 G, TOSA without Flex Circuit**

Part Number	Description
PL-SSD-00-S40-C2	Differential drive TOSA with SC housing, 4 leads
PL-SLD-00-S40-C2	Differential drive TOSA with LC housing, 4 leads
PL-SLD-00-S40-C5	Differential drive TOSA with LC housing, 5 leads

10 G, 5-lead TOSA with Flex Circuit

Part Number	Description
PL-FSC-00-S40-C4	Anode-drive TOSA with SC housing with flex
PL-FLC-00-S40-C4	Anode-drive TOSA with LC housing with flex
PL-FSD-00-S40-C5	Differential drive TOSA with SC housing with flex
PL-FLD-00-S40-C5	Differential drive TOSA with LC housing with flex
PL-FSA-00-S40-C6	Cathode-drive TOSA with SC housing with flex
PL-FLA-00-S40-C6	Cathode-drive TOSA with LC housing with flex