

SCHOTTKY BARRIER RECTIFIERS

REVERSE VOLTAGE - 30 to 100Volts
FORWARD CURRENT - 10.0 Amperes

FEATURES

- Metal of silicon rectifier , majority carrier conduction
- Guard ring for transient protection
- Low power loss,high efficiency
- High current capability,low VF
- High surge capacity
- Plastic package has UL flammability classification 94V-0
- For use in low voltage,high frequency inverters,free wheeling,and polarity protection applications

MECHANICAL DATA

- Case: TO-220AB molded plastic
- Polarity: As marked on the body
- Weight: 0.08ounces,2.24 grams
- Mounting position :Any

TO-220AB

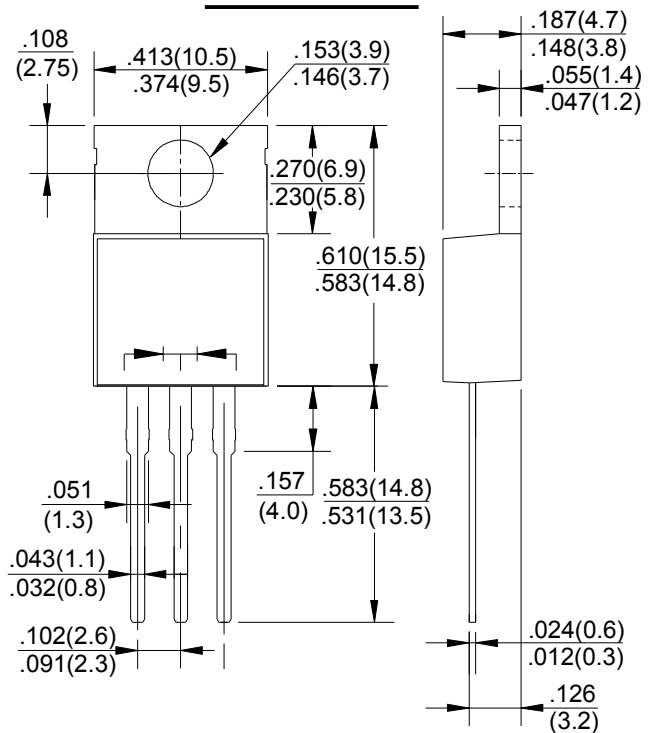

Dimensions in inches and (millimeters)

MAXIMUM RATINGS AND ELECTRICAL CHARACTERISTICS

Rating at 25°C ambient temperature unless otherwise specified.

Single phase, half wave ,60Hz, resistive or inductive load.

For capacitive load, derate current by 20%

CHARACTERISTICS	SYMBOL	MBR 1030CT	MBR 1040CT	MBR 1050CT	MBR 1060CT	MBR 1080CT	MBR 10100CT	UNIT
Maximum Recurrent Peak Reverse Voltage	V _{RRM}	30	40	50	60	80	100	V
Maximum RMS Voltage	V _{RMS}	21	28	35	42	56	70	V
Maximum DC Blocking Voltage	V _{DC}	30	40	50	60	80	100	V
Maximum Average Forward Rectified Current (See Fig.1)	I _(AV)	10.0						A
Peak Forward Surge Current 8.3ms Single Half Sine-Wave Super Imposed on Rated Load (JEDEC Method)	I _{FSM}	125						A
Peak Forward Voltage (Note1) IF=5A @T _J =25°C IF=5A @T _J =125°C IF=10A @T _J =25°C IF=10A @T _J =125°C	V _F	0.70		0.80		0.85		V
Maximum DC Reverse Current at Rated DC Bolcking Voltage	I _R	0.1 15						mA
Typical Junction Capacitance (Note2)	C _J	170		220		300		pF
Typical Thermal Resistance (Note3)	R _{θJC}	3.0				3.0		°C/W
Operating Temperature Range	T _J	-55 to +150						°C
Storage Temperature Range	T _{STG}	-55 to +175						°C

NOTES:1.300us pulse width,2% duty cycle.

2.Measured at 1.0 MHz and applied reverse voltage of 4.0V DC.

3.Thermal resistance junction to case.

RATING AND CHARACTERISTIC CURVES
MBR1030CT thru MBR10100CT



FIG. 1 – FORWARD CURRENT DERATING CURVE

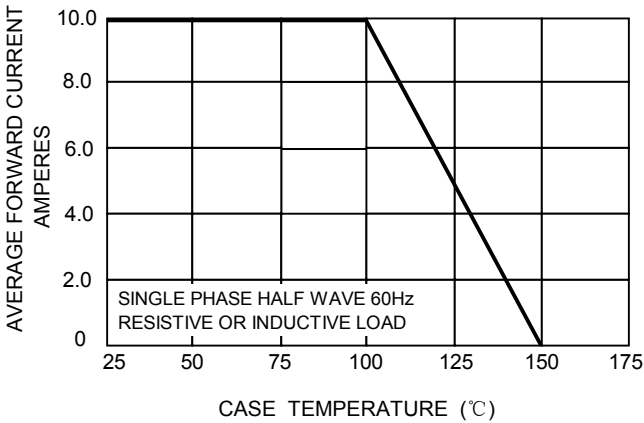

FIG. 2 – MAXIMUM NON-REPETITIVE SURGE CURRENT

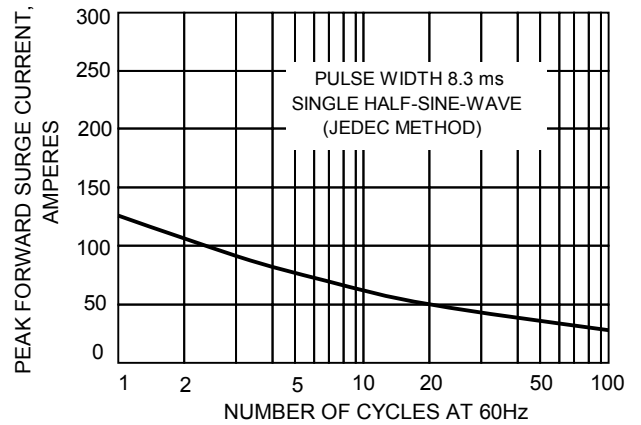

FIG.3-TYPICAL REVER CHARACTERISTICS

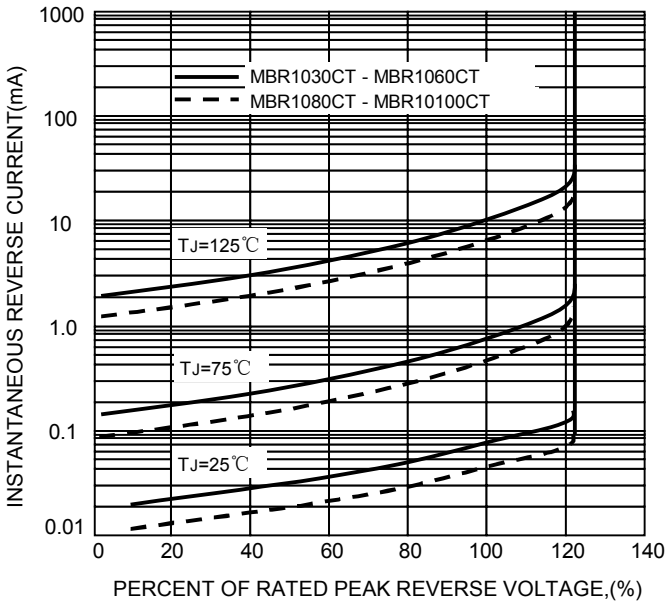

FIG.4-TYPICAL FORWARD CHARACTERISTICS

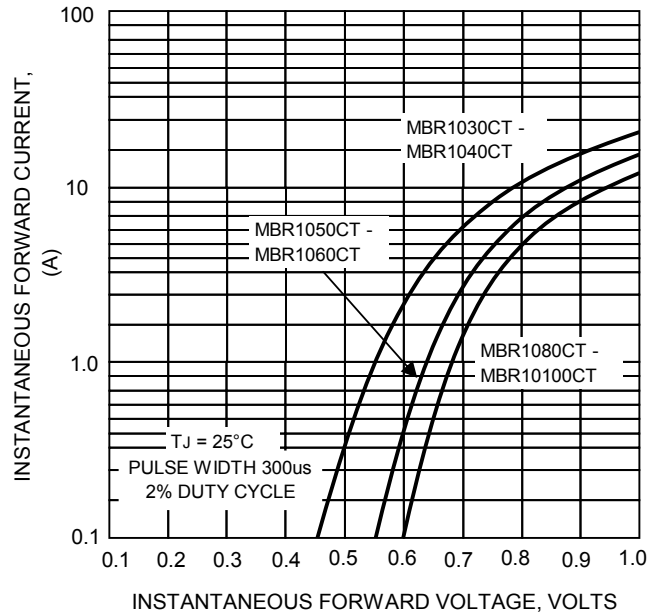

FIG.5 – TYPICAL JUNCTION CAPACITANCE

