

SCHOTTKY BARRIER RECTIFIERS

REVERSE VOLTAGE - 30 to 150Volts
FORWARD CURRENT - 20.0 Amperes

FEATURES

- Metal of silicon rectifier , majority carrier conduction
- Guard ring for transient protection
- Low power loss,high efficiency
- High current capability,low VF
- High surge capacity
- Plastic package has UL flammability classification 94V-0
- For use in low voltage,high frequency inverters,free wheeling,and polarity protection applications

MECHANICAL DATA

- Case: TO-220AB molded plastic
- Polarity: As marked on the body
- Weight: 0.08ounces,2.24 grams
- Mounting position :Any

TO-220AB

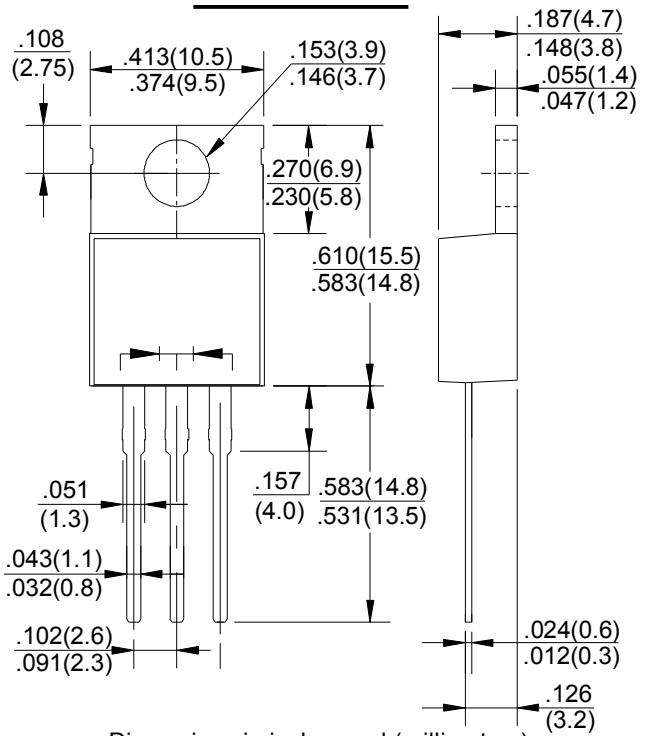

MAXIMUM RATINGS AND ELECTRICAL CHARACTERISTICS

Rating at 25°C ambient temperature unless otherwise specified.

Single phase, half wave ,60Hz, resistive or inductive load.

For capacitive load, derate current by 20%

CHARACTERISTICS	SYMBOL	MBR 2030CT	MBR 2040CT	MBR 2050CT	MBR 2060CT	MBR 2080CT	MBR 20100CT	MBR 20150CT	UNIT	
Maximum Recurrent Peak Reverse Voltage	V _{RRM}	30	40	50	60	80	100	150	V	
Maximum RMS Voltage	V _{RMS}	21	28	35	42	56	70	105	V	
Maximum DC Blocking Voltage	V _{DC}	30	40	50	60	80	100	150	V	
Maximum Average Forward Rectified Current (See Fig.1)	I <sub(av)< sub=""></sub(av)<>	20.0							A	
Peak Forward Surge Current 8.3ms Single Half Sine-Wave Super Imposed on Rated Load (JEDEC Method)	I _{FSM}	150							A	
Peak Forward Voltage (Note1)	V _F	-	0.57	0.70	0.80	0.85	0.95	0.95	V	
			0.84	0.95	0.70	0.75	0.85	0.85		
			0.72	0.85	0.95	0.95	1.05	1.05		
			0.72	0.85	0.85	0.85	0.95	0.95		
Maximum DC Reverse Current at Rated DC Bolcking Voltage	I _R	0.1	15	10	0.1	0.1	0.1	0.1	mA	
							7.5	5.0		
Typical Junction Capacitance (Note2)	C _J	400			320				pF	
Typical Thermal Resistance (Note3)	R _{θJC}	1.5				3.5				°C/W
Operating Temperature Range	T _J	-55 to +150							°C	
Storage Temperature Range	T _{STG}	-55 to +175							°C	

NOTES:1.300us pulse width,2% duty cycle.

2.Measured at 1.0 MHz and applied reverse voltage of 4.0V DC.

3.Thermal resistance junction to case.

RATING AND CHARACTERISTIC CURVES
MBR2030CT thru MBR20150CT



FIG. 1 – FORWARD CURRENT DERATING CURVE

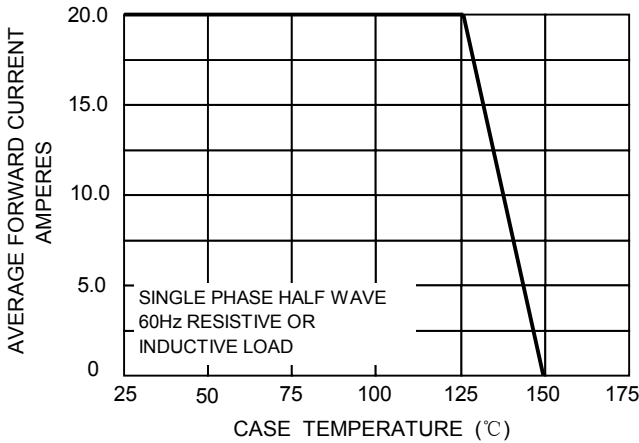

FIG. 2 – MAXIMUM NON-REPETITIVE SURGE CURRENT

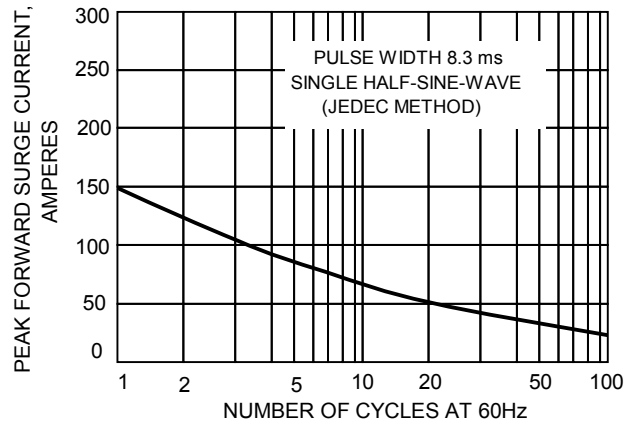

FIG.3-TYPICAL REVER CHARACTERISTICS

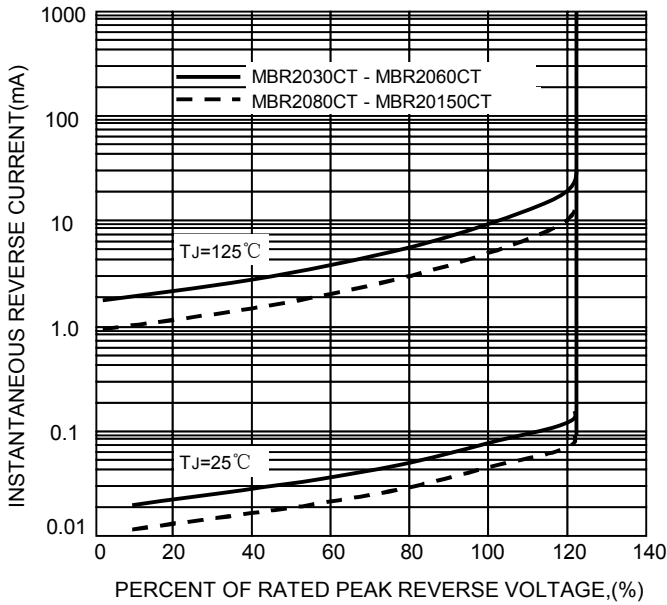

FIG.4-TYPICAL FORWARD CHARACTERISTICS

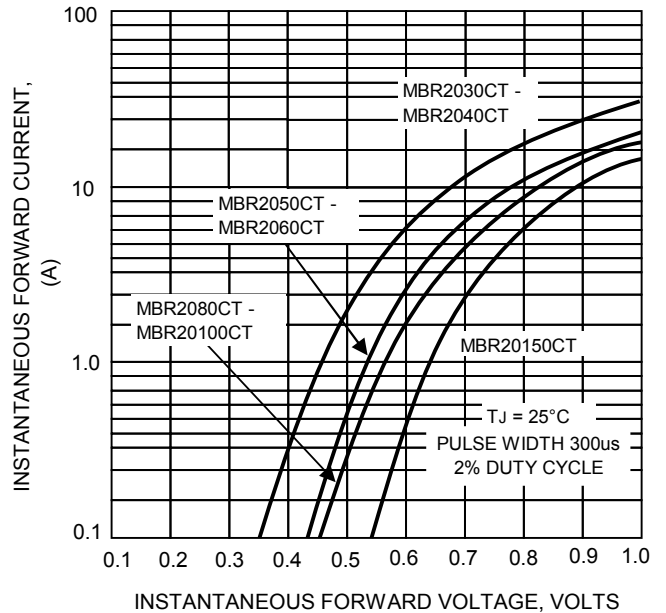

FIG.5 – TYPICAL JUNCTION CAPACITANCE

