

Low Voltage 300mA LDO REGULATOR

NO.EA-116-061102

OUTLINE

The R1131x Series are CMOS-based low voltage regulator ICs with output voltage range from 0.8V to 3.3V. The minimum operating voltage is 1.4V. Each of these voltage regulator ICs consists of a voltage reference unit, an error amplifier, resistors for setting output voltage, a current limit circuit, and a chip enable circuit.

To prevent the destruction by over current, current limit circuit is included. Standby mode realizes ultra small consumption current.

The output voltage of these ICs is internally fixed with high accuracy. Since the packages for these ICs are SOT-23-5, SON-6, and HSON-6, high density mounting of the ICs on boards is possible.

FEATURES

- Supply Current Typ. 80 μ A ($V_{OUT} < 1.8V$)
Typ. 60 μ A ($V_{OUT} \geq 1.8V$)
- Standby Mode Typ. 0.1 μ A
- Low Dropout Voltage..... Typ. 0.48V($I_{OUT}=300mA$ Output Voltage=1.0V Type)
Typ. 0.31V($I_{OUT}=300mA$ Output Voltage=1.5V Type)
Typ. 0.23V($I_{OUT}=300mA$ Output Voltage=3.0V Type)
- Ripple Rejection Typ. 65dB($f=1kHz$)
- Low Temperature-Drift Coefficient of Output Voltage Typ. $\pm 100ppm/^{\circ}C$
- Excellent Line Regulation Typ. 0.01%/V
- Output Voltage Accuracy..... $\pm 2.0\%$
- Packages SOT-23-5, SON-6, HSON-6
- Output Voltage Range..... 0.8V to 3.3V
- Input Voltage Range 1.4V to 3.3V
- Built-in fold-back protection circuit Typ. 50mA (Current at short mode)
- External Capacitors..... $C_{IN}=C_{OUT}=\text{Tantalum } 1.0\mu F$ ($V_{OUT} < 1.0V$)
 $C_{IN}=C_{OUT}=\text{Ceramic } 1.0\mu F$ ($V_{OUT} \geq 1.0V$)

APPLICATIONS

- Precision Voltage References.
- Power source for electrical appliances such as cameras, VCRs and hand-held communication equipment.
- Power source for battery-powered equipment.

BLOCK DIAGRAM

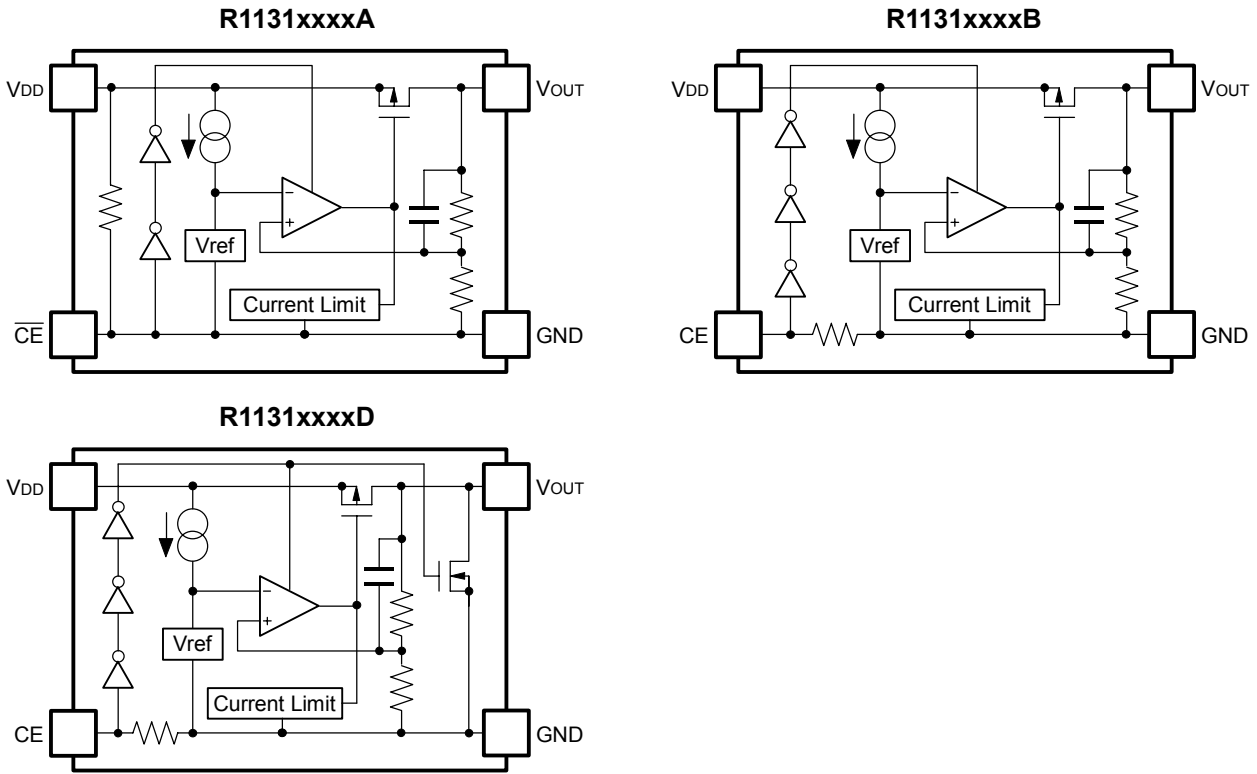

SELECTION GUIDE

The output voltage, the chip enable polarity, package type, and the taping type for the ICs can be selected at the user's request. The selection can be available by designating the part number as shown below;

R1131xxxx-xx-x ←Part Number
 ↑↑↑↑↑
 a b a'c d e

Code	Contents
a, a'	Designation of Package Type : R1131Nxx1x: SOT-23-5 (Mini-mold) R1131Dxx1x: SON-6, R1131Dxx2x: HSON-6
b	Setting Output Voltage (V_{OUT}): Stepwise setting with a step of 0.1V in the range of 0.8V to 3.3V is possible. If the output=1.85V, then the code is R1131x18xx5. If the output=2.85V, then the code is R1131x28xx5.
c	Designation of Chip Enable Option : A: "L" active type. B: "H" active type. D: "H" active and with auto discharge function
d	Designation of Taping Type : TR Refer to Taping Specifications
e	Designation of composition of plating: -F : Lead free plating (SOT-23-5,SON-6,HSON-6)

PIN CONFIGURATIONS

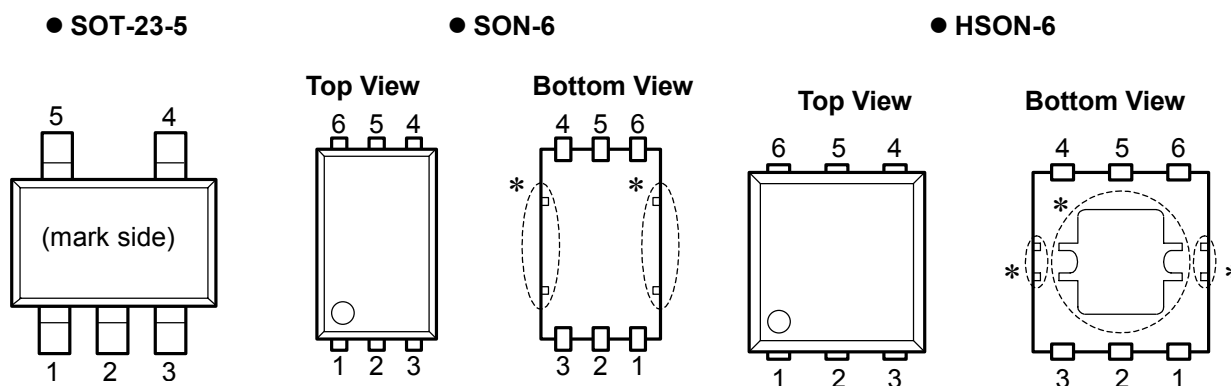

PIN DESCRIPTIONS

● SOT-23-5

Pin No.	Symbol	Description
1	V_{DD}	Input Pin
2	GND	Ground Pin
3	\overline{CE} or CE	Chip Enable Pin
4	NC	No Connection
5	V_{OUT}	Output pin

● SON-6,HSON-6

Pin No.	Symbol	Description
1	V_{DD}	Input Pin
2	NC	No Connection
3	V_{OUT}	Output pin
4	NC	No Connection
5	GND	Ground Pin
6	\overline{CE} or CE	Chip Enable Pin

* Tab or Tab suspension leads in the  parts have GND level.

(They are connected to the reverse side of this IC.)
Do not connect to other wires or land patterns.

ABSOLUTE MAXIMUM RATINGS

Symbol	Item	Rating	Unit
V_{IN}	Input Voltage	6.5	V
V_{CE}	Input Voltage (\overline{CE} /CE Pin)	-0.3 to 6.5	V
V_{OUT}	Output Voltage	-0.3 to $V_{IN}+0.3$	V
I_{OUT}	Output Current	350	mA
P_D	Power Dissipation (SOT23-5)* ¹	420	mW
	Power Dissipation (SON-6)* ¹	500	
	Power Dissipation (HSON-6)* ¹	900	
T_{opt}	Operating Temperature Range	-40 to 85	°C
T_{stg}	Storage Temperature Range	-55 to 125	°C

*1) For Power Dissipation please refer to PACKAGE INFORMATION to be described.

ELECTRICAL CHARACTERISTICS

• R1131xxxxA

T_{opt}=25°C

Symbol	Item	Conditions	Min.	Typ.	Max.	Unit
V _{OUT}	Output Voltage	V _{IN} =Set V _{OUT} +1V 1μA ≤ I _{OUT} ≤ 30mA	V _{OUT} < 1.8V	×0.98	×1.02	V
			V _{OUT} ≤ 1.8V	-30	+30	mV
I _{OUT}	Output Current	V _{IN} -V _{OUT} =1.0V	300			mA
ΔV _{OUT} / ΔI _{OUT}	Load Regulation	V _{IN} =Set V _{OUT} +1V, 1mA ≤ I _{OUT} ≤ 300mA		40	70	mV
V _{DIF}	Dropout Voltage	Refer to the ELECTRICAL CHARACTERISTICS by OUTPUT VOLTAGE				
I _{SS1}	Supply Current	V _{IN} =Set V _{OUT} +1V, V _{OUT} < 1.8V		80	111	μA
		V _{IN} =Set V _{OUT} +1V, V _{OUT} ≥ 1.8V		60	90	μA
I _{standby}	Supply Current (Standby)	V _{IN} =V _{CE} =Set V _{OUT} +1V		0.1	1.0	μA
ΔV _{OUT} / ΔV _{IN}	Line Regulation	I _{OUT} =30mA V _{OUT} +0.5V ≤ V _{IN} ≤ 6.0V (V _{OUT} > 0.9V) 1.4V ≤ V _{IN} ≤ 6.0V (V _{OUT} ≤ 0.9V)		0.01	0.15	%/V
RR	Ripple Rejection	f=1kHz, Ripple 0.2Vp-p V _{IN} =Set V _{OUT} +1V, I _{OUT} =30mA		65		dB
V _{IN}	Input Voltage		1.4		6.0	V
ΔV _{OUT} / ΔT _{opt}	Output Voltage Temperature Coefficient	I _{OUT} =30mA -40°C ≤ T _{opt} ≤ 85°C		±100		ppm /°C
I _{lim}	Short Current Limit	V _{OUT} =0V		50		mA
R _{PU}	$\overline{\text{CE}}$ Pull-up Resistance		1.87	5.0	12.0	MΩ
V _{CEH}	$\overline{\text{CE}}$ Input Voltage "H"		1.0		6.0	V
V _{CEL}	$\overline{\text{CE}}$ Input Voltage "L"		0.0		0.3	V
en	Output Noise	BW=10Hz to 100kHz		30		μVrms

• R1131xxxxB/D

T_{opt}=25°C

Symbol	Item	Conditions	Min.	Typ.	Max.	Unit
V _{OUT}	Output Voltage	V _{IN} =Set V _{OUT} +1V 1μA ≤ I _{OUT} ≤ 30mA	V _{OUT} < 1.8V	×0.98	×1.02	V
			V _{OUT} ≤ 1.8V	-30	+30	mV
I _{OUT}	Output Current	V _{IN} -V _{OUT} =1.0V	300			mA
ΔV _{OUT} / ΔI _{OUT}	Load Regulation	V _{IN} =Set V _{OUT} +1V 1mA ≤ I _{OUT} ≤ 300mA		40	70	mV
V _{DIF}	Dropout Voltage	Refer to the ELECTRICAL CHARACTERISTICS by OUTPUT VOLTAGE				
I _{SS1}	Supply Current	V _{IN} =Set V _{OUT} +1V, V _{OUT} < 1.8V		80	111	μA
		V _{IN} =Set V _{OUT} +1V, V _{OUT} ≥ 1.8V		60	90	μA
I _{standby}	Supply Current (Standby)	V _{IN} =Set V _{OUT} +1V, V _{CE} =GND		0.1	1.0	μA
ΔV _{OUT} / ΔV _{IN}	Line Regulation	I _{OUT} =30mA V _{OUT} +0.5V ≤ V _{IN} ≤ 6.0V (V _{OUT} > 0.9V) 1.4V ≤ V _{IN} ≤ 6.0V (V _{OUT} ≤ 0.9V)		0.01	0.15	%/V
RR	Ripple Rejection	f=1kHz, Ripple 0.2Vp-p V _{IN} =Set V _{OUT} +1V, I _{OUT} =30mA		65		dB
V _{IN}	Input Voltage		1.4		6.0	V
ΔV _{OUT} / ΔT _{opt}	Output Voltage Temperature Coefficient	I _{OUT} =30mA -40°C ≤ T _{opt} ≤ 85°C		±100		ppm /°C
I _{lim}	Short Current Limit	V _{OUT} =0V		50		mA
R _{PD}	CE Pull-down Resistance		1.87	5.0	12.0	MΩ
V _{CEH}	CE Input Voltage "H"		1.0		V _{IN}	V
V _{CEL}	CE Input Voltage "L"		0.0		0.3	V
en	Output Noise	BW=10Hz to 100kHz		30		μVrms
R _{LOW}	Nch On Resistance for auto discharge (applied to D version only)	V _{CE} =0V		60		Ω

• Electrical Characteristics by Output Voltage

Output Voltage V _{OUT} (V)	Dropout Voltage V _{DIF} (mV)		
	Condition	Typ.	Max.
0.8=V _{OUT}	I _{OUT} =300mA	620	850
0.9=V _{OUT}		550	780
1.0 ≤ V _{OUT} < 1.5		480	700
1.5 ≤ V _{OUT} < 2.6		310	450
2.6 ≤ V _{OUT} ≤ 3.3		230	350

TECHNICAL NOTES

When using these ICs, consider the following points:

Phase Compensation

In these ICs, phase compensation is made for securing stable operation even if the load current is varied. For this purpose, be sure to use a 1.0 μ F or more capacitor C_{OUT} with good frequency characteristics and ESR (Equivalent Series Resistance).

(Note: If a tantalum capacitor is connected to the Output pin for phase compensation, if the ESR value of the capacitor is too large, the operation might be unstable. Because of this, test these ICs with as same external components as ones to be used on the PCB.)

Chip capacitor characteristics of Bias dependence and Temperature characteristics may vary depending on its size, manufacturer, and part number.

PCB Layout

Make V_{DD} and GND lines sufficient. If their impedance is high, pick-up the noise or unstable operation may result. Connect a capacitor with as much as 1.0mF capacitor between V_{DD} and GND pin as close as possible.

Set external components, especially the output capacitor, as close as possible to the ICs, and make wiring as short as possible.

TYPICAL APPLICATION

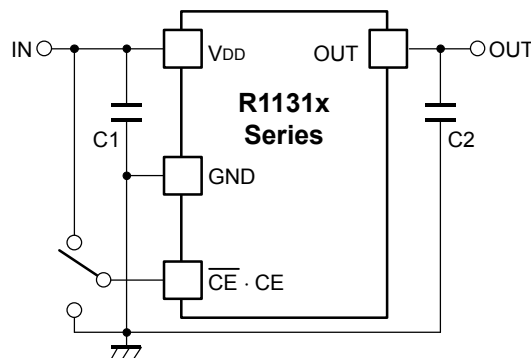

<External Components examples>

CM05X5R105K06AB (Kyocera)

C1005JBOJ105K (TDK)

GRM155B30J105KE18B (Murata)

Output Capacitor; 1.0 μ F or more capacity ceramic Type

(If V_{OUT} < 1.0V, Tantalum Type is recommended)

Input Capacitor, 1.0 μ F or more capacity ceramic Type

TEST CIRCUIT

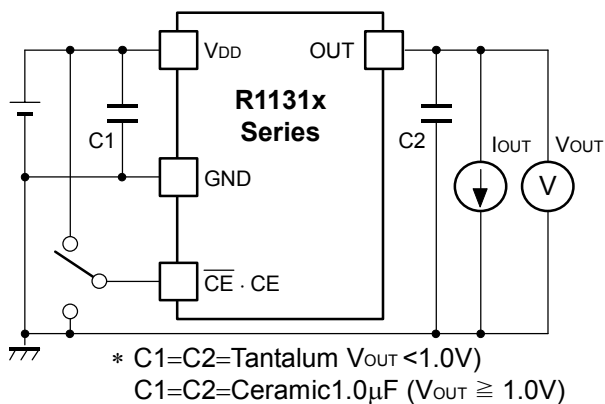

Standard Test Circuit

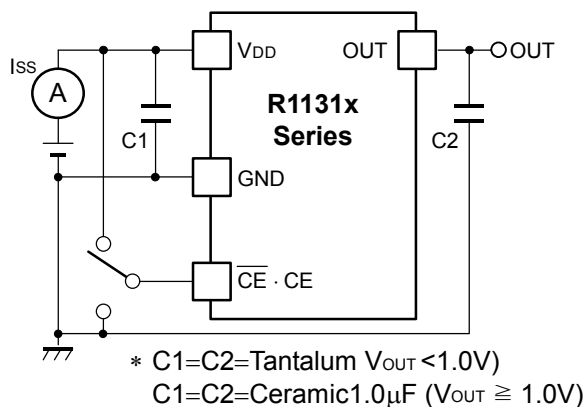

Supply Current Test Circuit

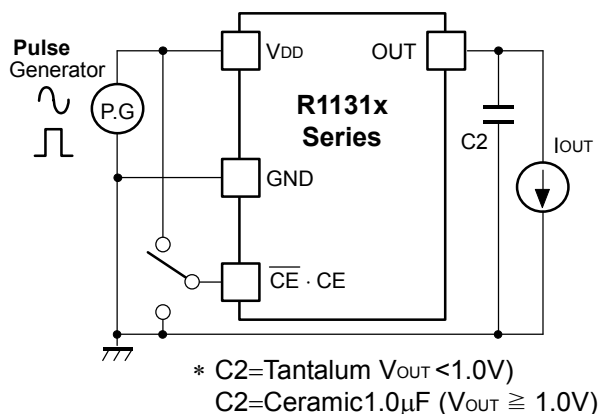

Ripple Rejection, Line Transient Response Test Circuit

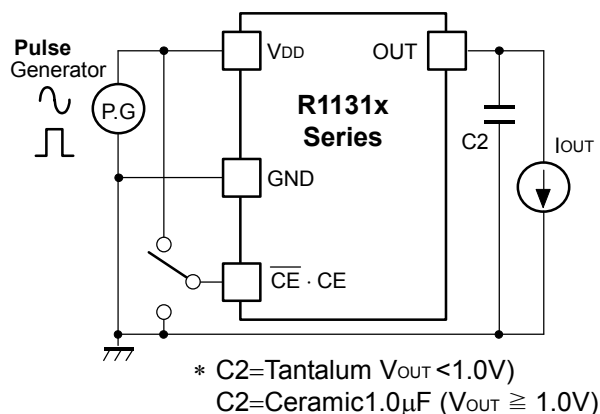

Load Transient Response Test Circuit

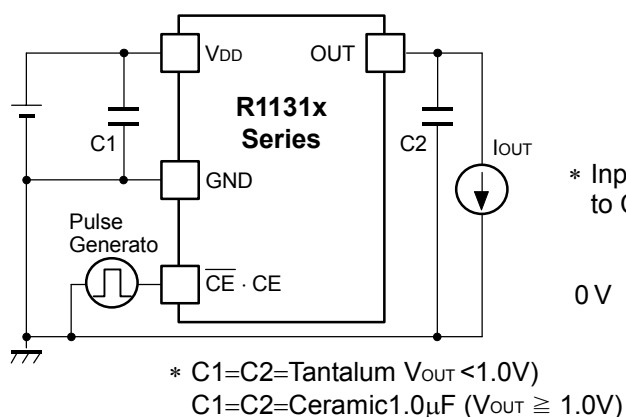

Turn on Speed with CE pin Test Circuit

* Input signal waveform to CE pin is shown below.

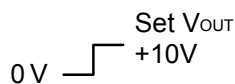

TYPICAL CHARACTERISTICS

1) Output Voltage vs. Output Current

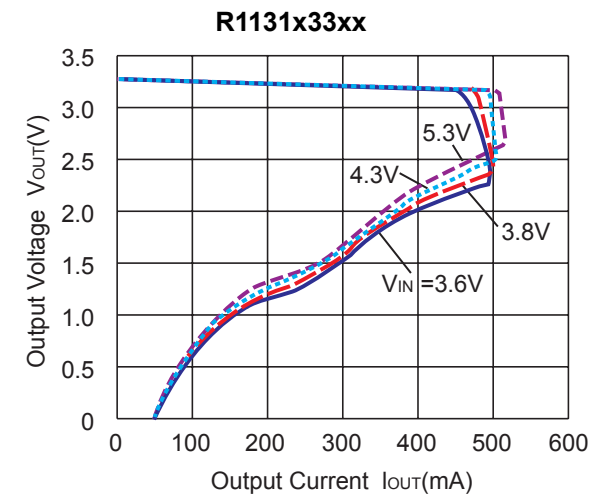
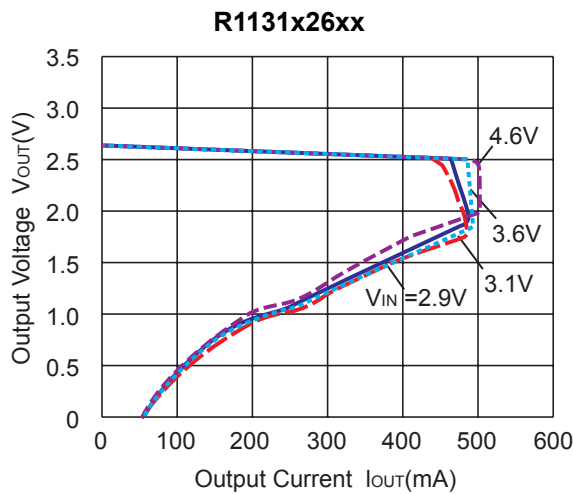
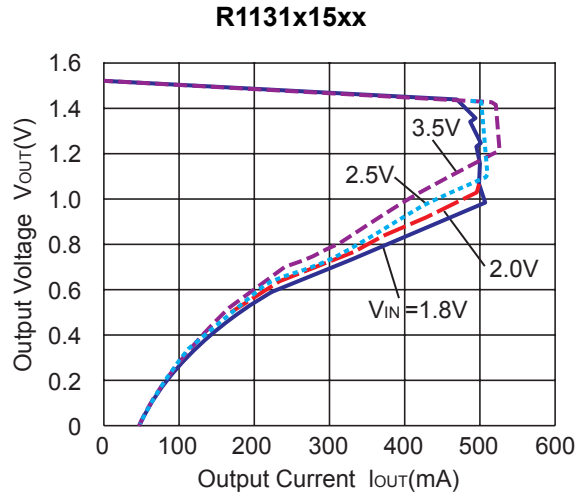
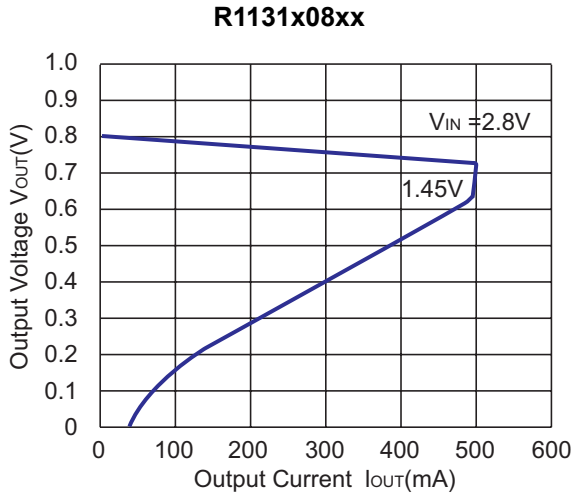

2) Output Voltage vs. Input Voltage

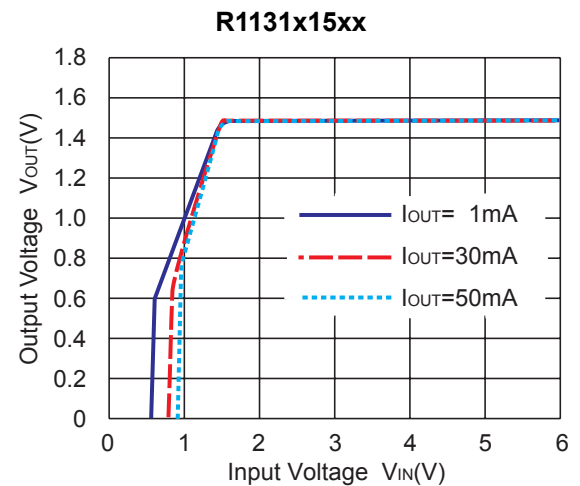
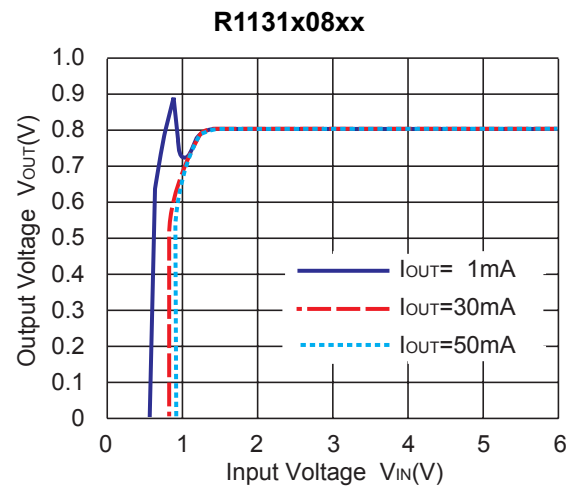

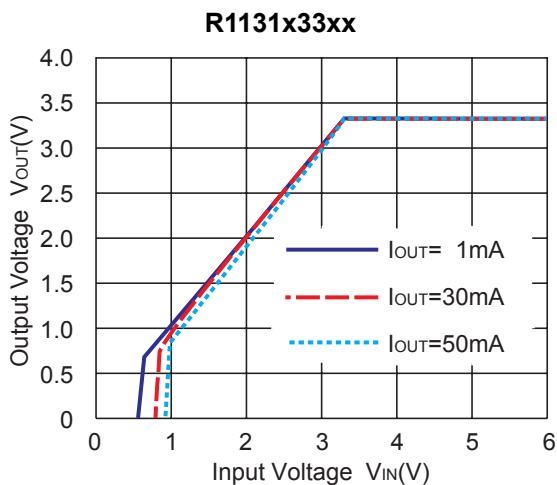
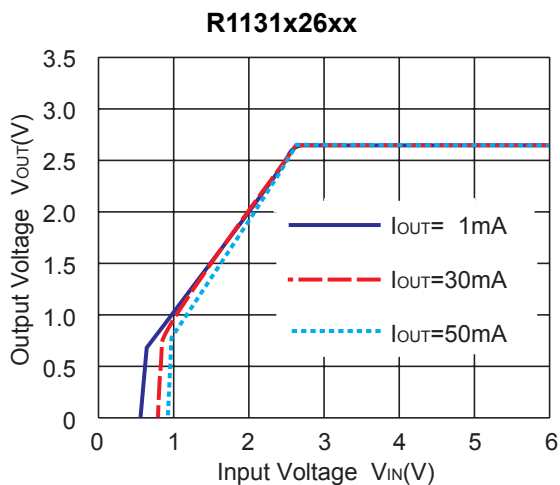

3) Supply Current vs. Input Voltage

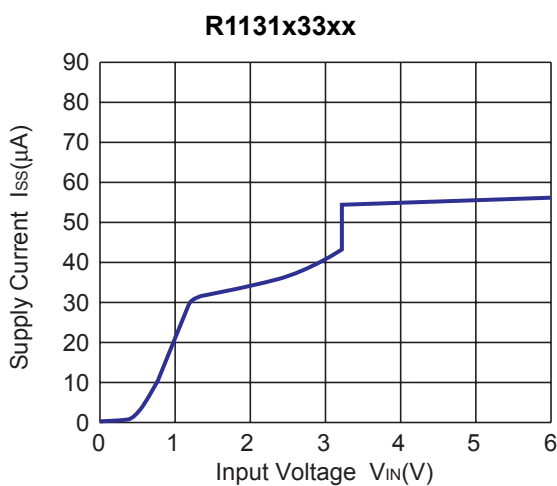
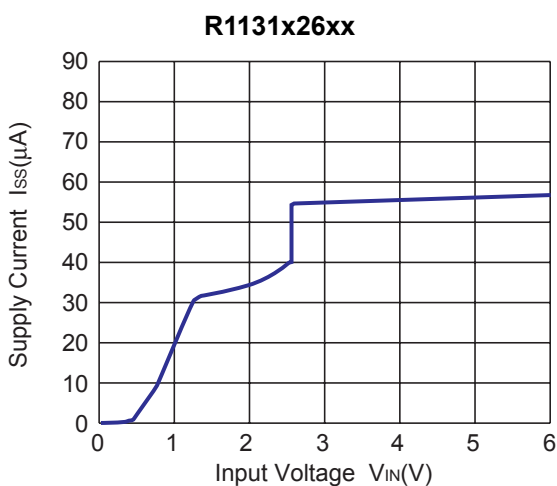
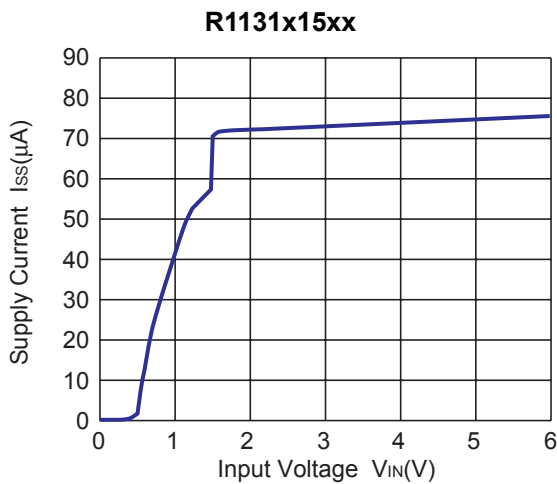
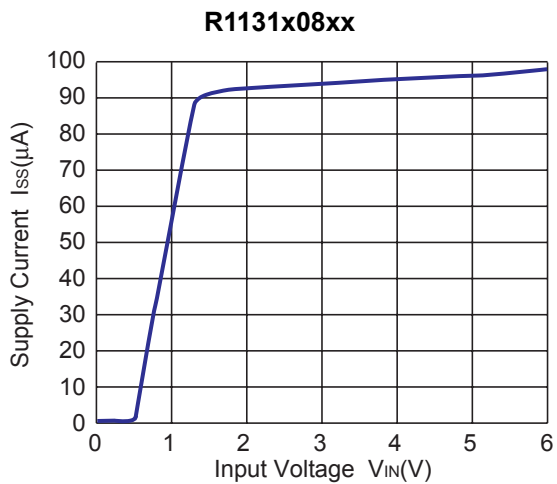

4) Output Voltage vs. Temperature

R1131x08xx

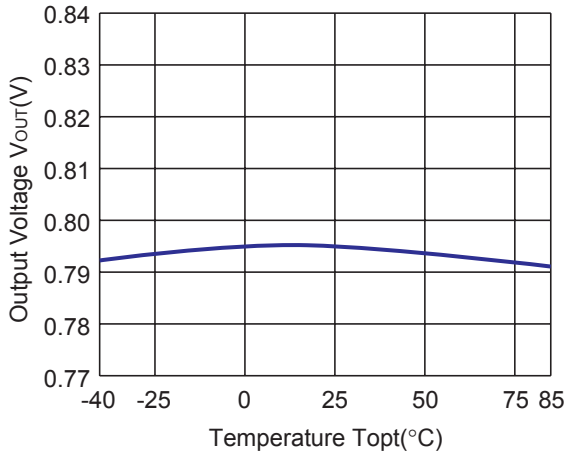

R1131x15xx

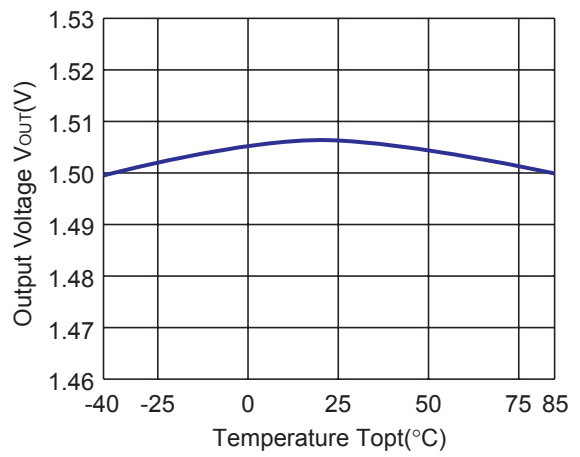

R1131x26xx

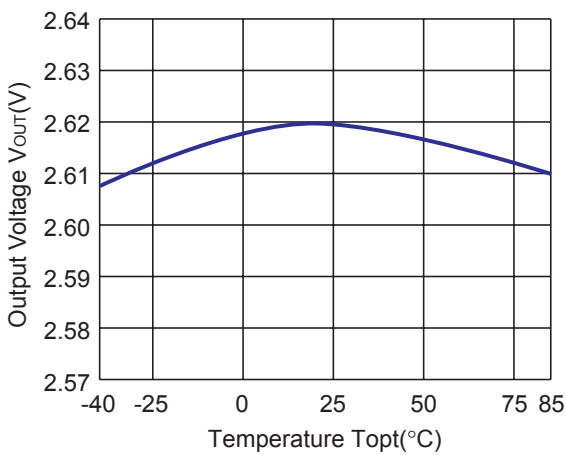

R1131x33xx

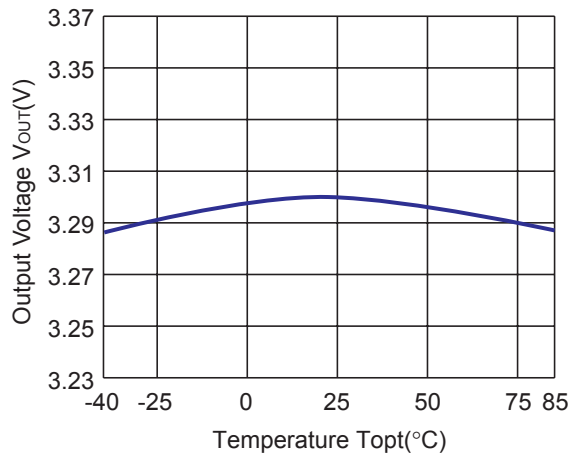

5) Supply Current vs. Temperature

R1131x08xx

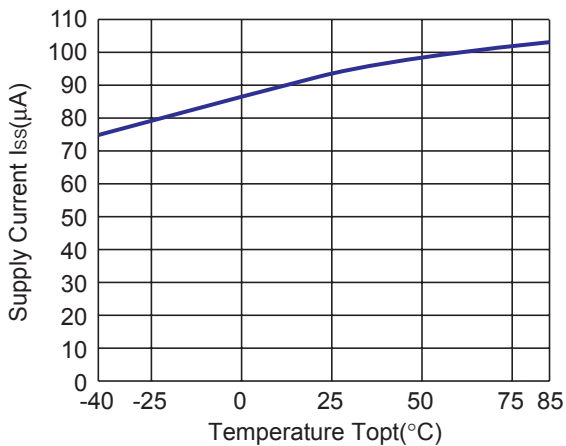

R1131x15xx

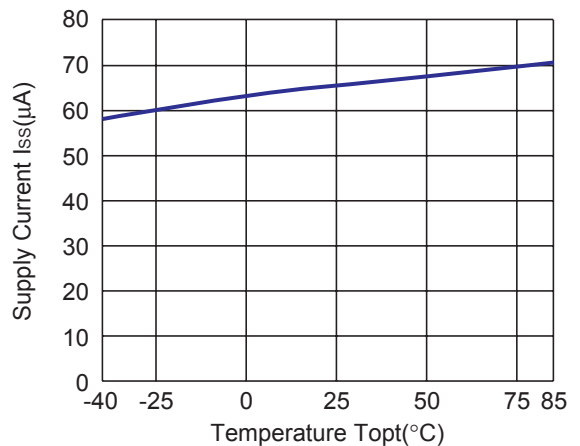

R1131x26xx

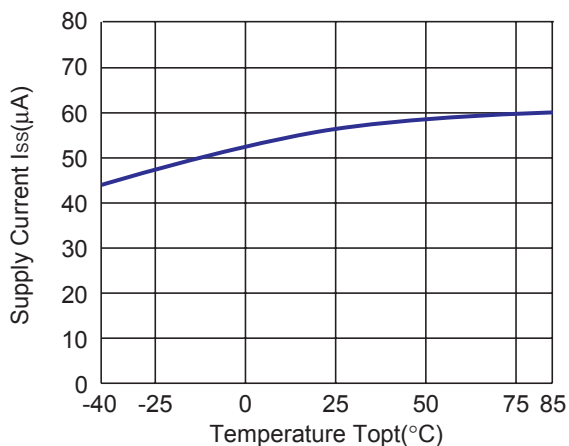

R1131x33xx

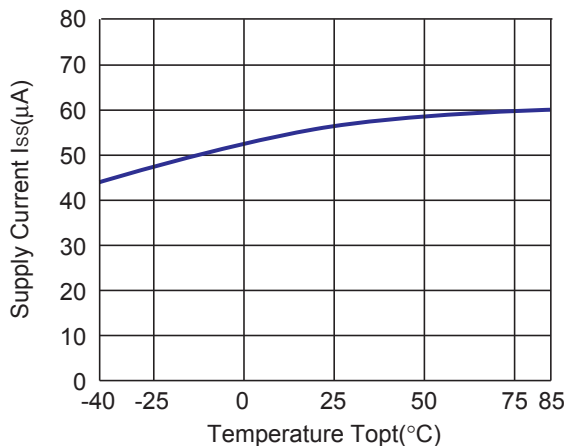

6) Dropout Voltage vs. Output Current

R1131x08xx

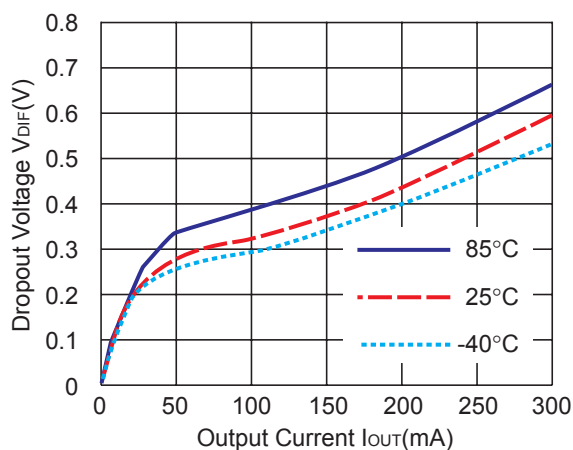

R1131x09xx

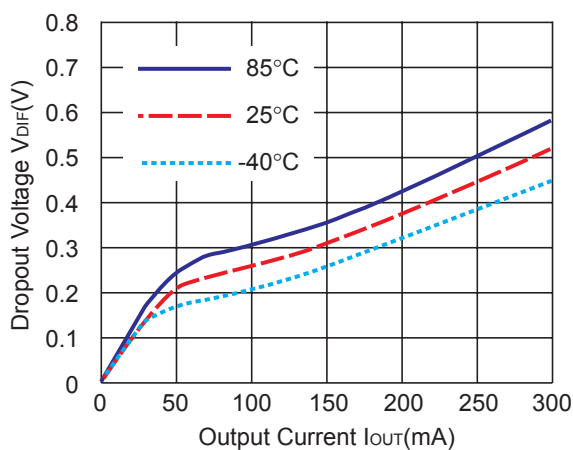

R1131x10xx

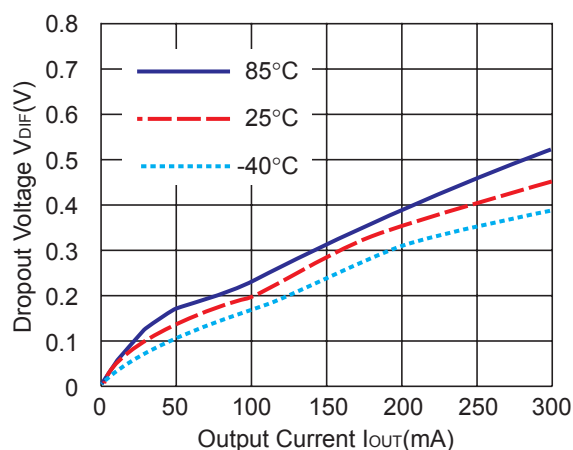

R1131x15xx

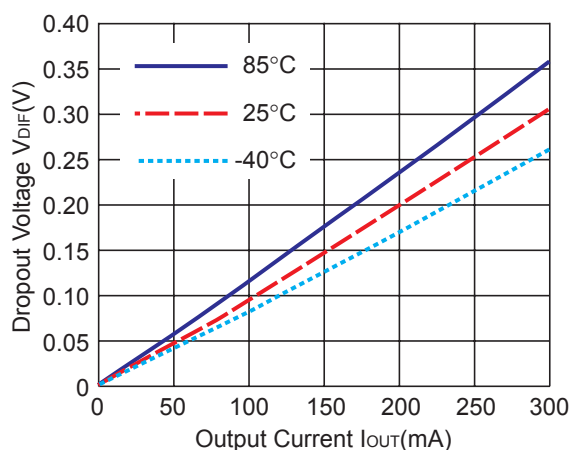

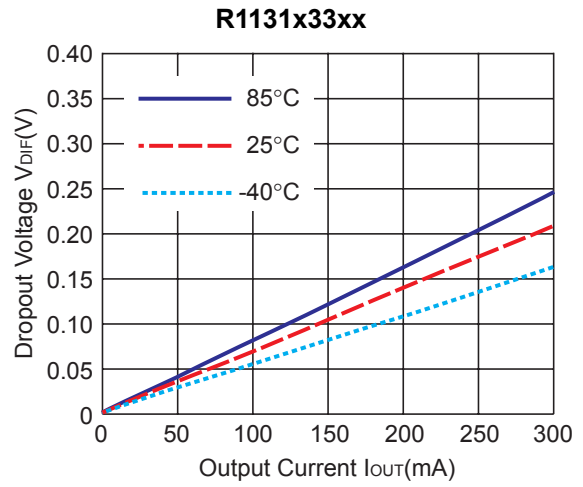
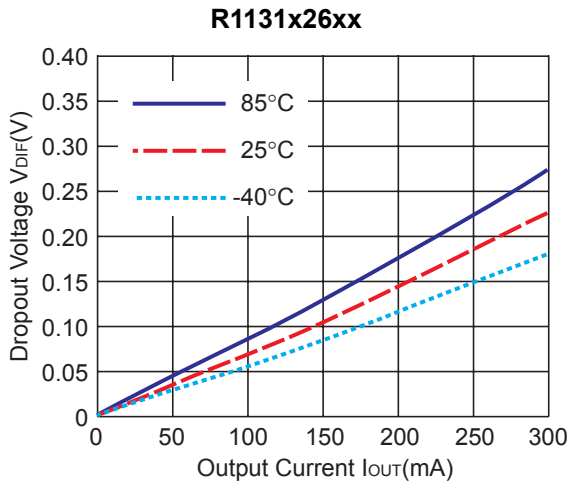

7) Dropout Voltage vs. Set Output Voltage (T_{opt}=25°C)

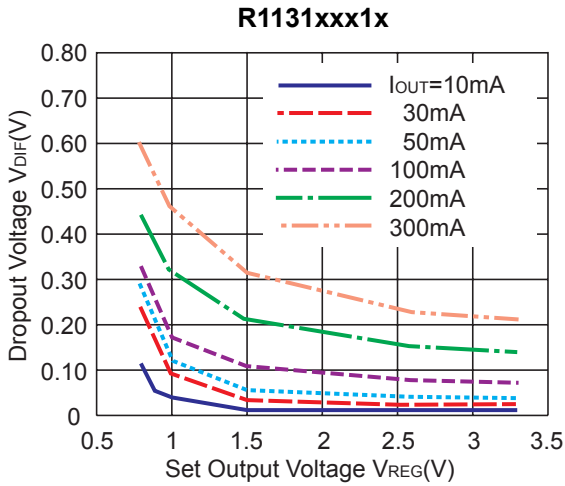

8) Ripple Rejection vs. Input Bias (T_{opt}=25°C C_{IN}=none, C_{OUT}=Ceramic 1.0μF Ripple 0.2V_{P-P})

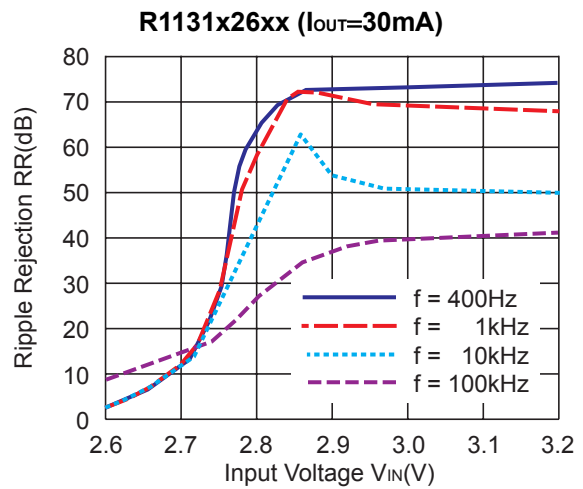
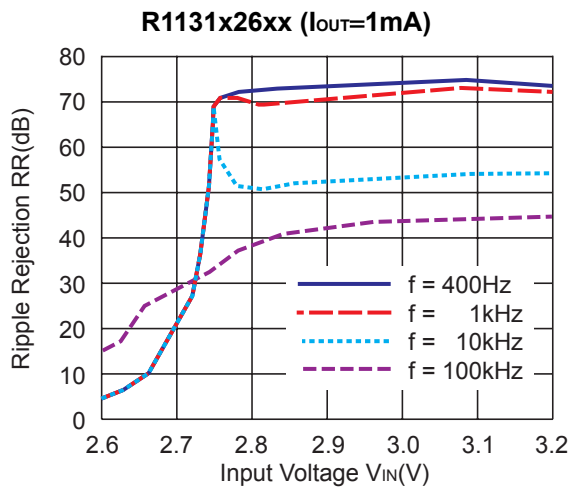

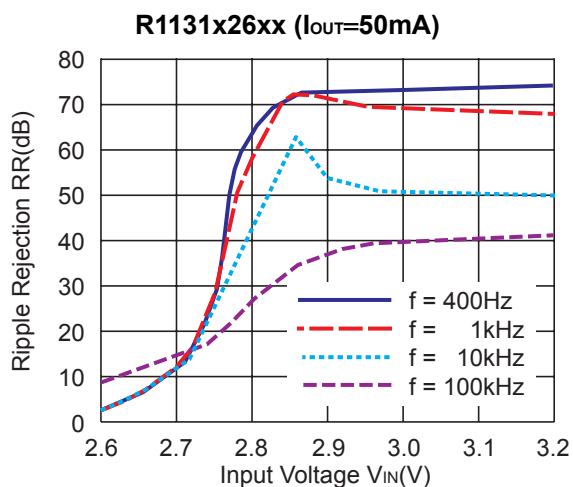

9) Ripple Rejection vs. Frequency (C_{IN}=none)

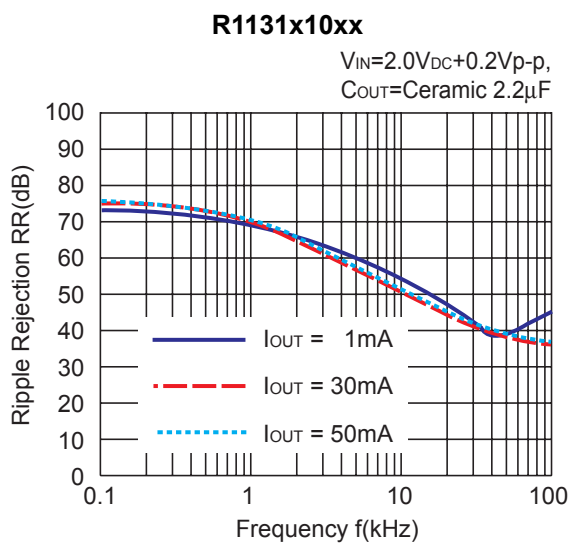
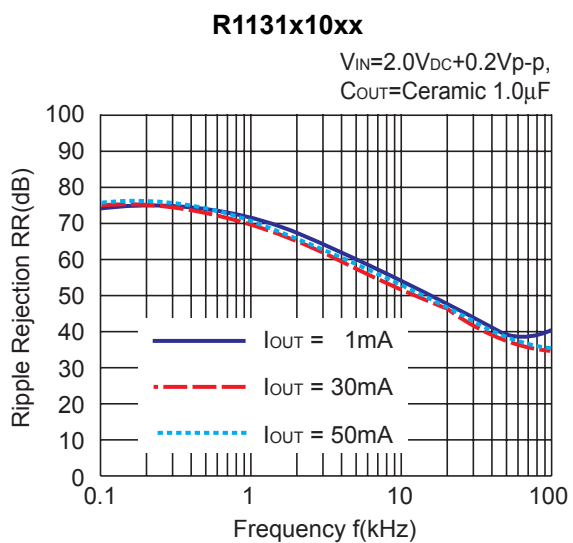
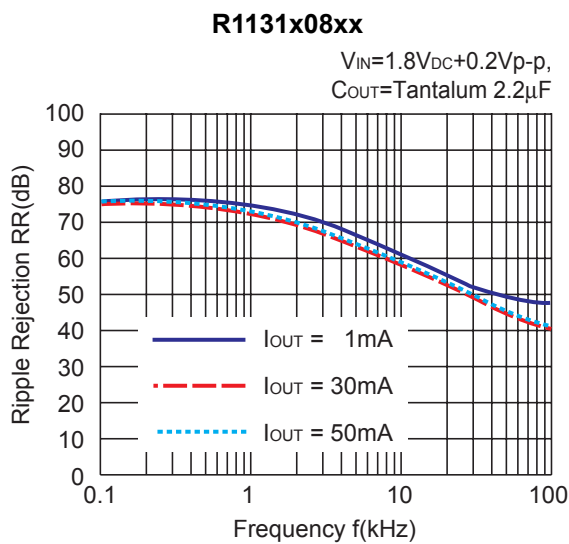
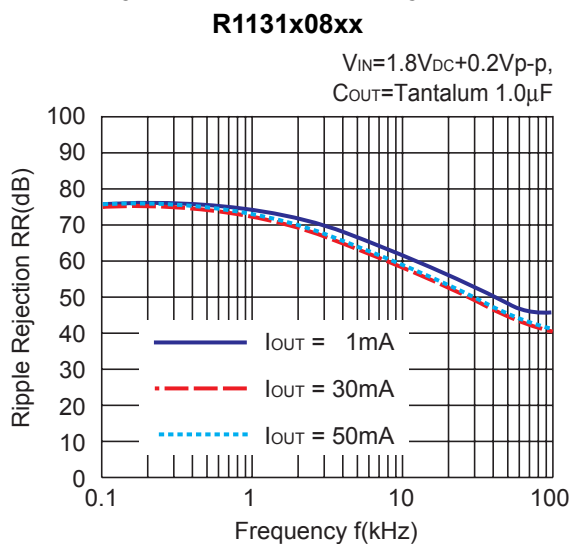

R1131x15xx

$V_{IN}=2.5V_{DC}+0.2V_{p-p}$,
 $C_{OUT}=\text{Ceramic } 1.0\mu\text{F}$

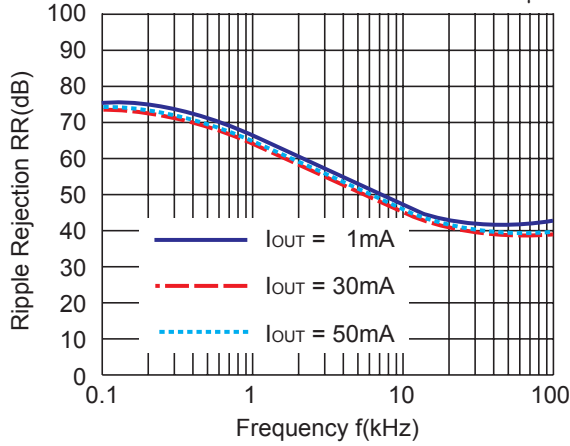

R1131x15xx

$V_{IN}=2.5V_{DC}+0.2V_{p-p}$,
 $C_{OUT}=\text{Ceramic } 2.2\mu\text{F}$

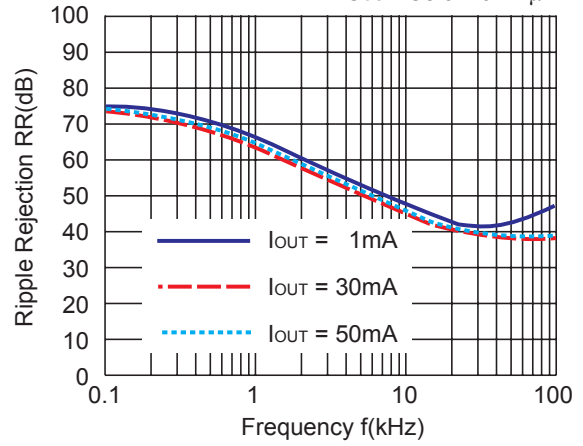

R1131x26xx

$V_{IN}=3.6V_{DC}+0.2V_{p-p}$,
 $C_{OUT}=\text{Ceramic } 1.0\mu\text{F}$

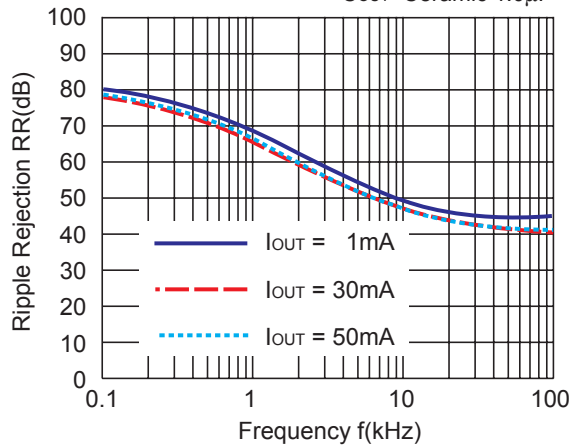

R1131x26xx

$V_{IN}=3.6V_{DC}+0.2V_{p-p}$,
 $C_{OUT}=\text{Ceramic } 2.2\mu\text{F}$

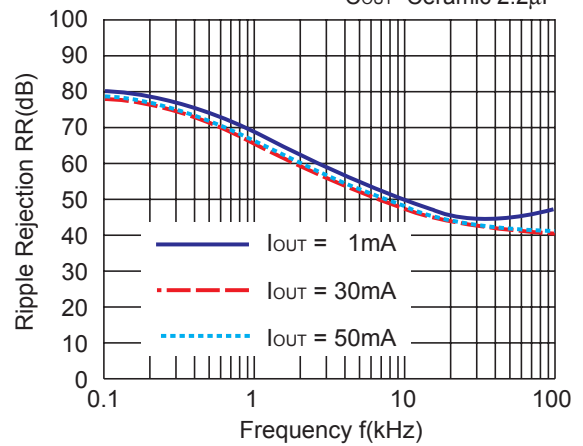

R1131x33xx

$V_{IN}=4.3V_{DC}+0.2V_{p-p}$,
 $C_{OUT}=\text{Ceramic } 1.0\mu\text{F}$

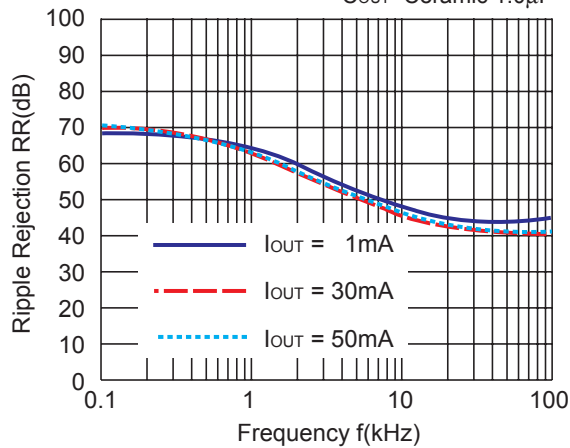

R1131x33xx

$V_{IN}=4.3V_{DC}+0.2V_{p-p}$,
 $C_{OUT}=\text{Ceramic } 2.2\mu\text{F}$

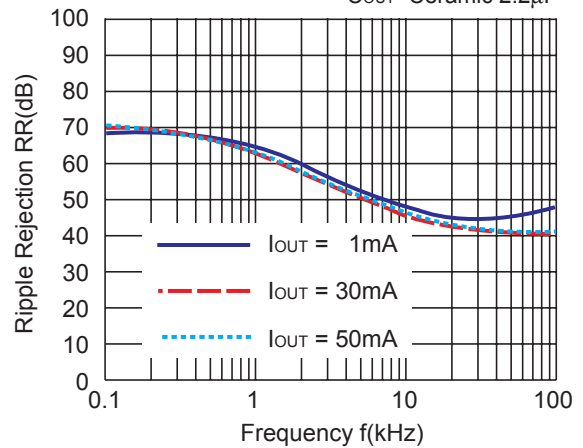

10) Input Transient Response ($C_{IN}=none, tr=tf=5\mu s$)

R1131x08xx

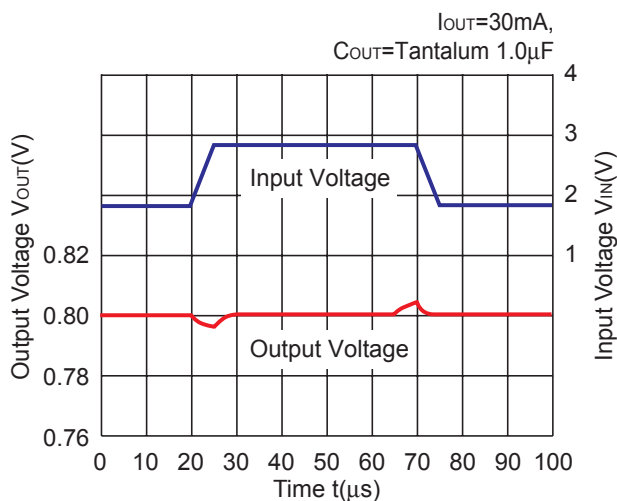

R1131x10x

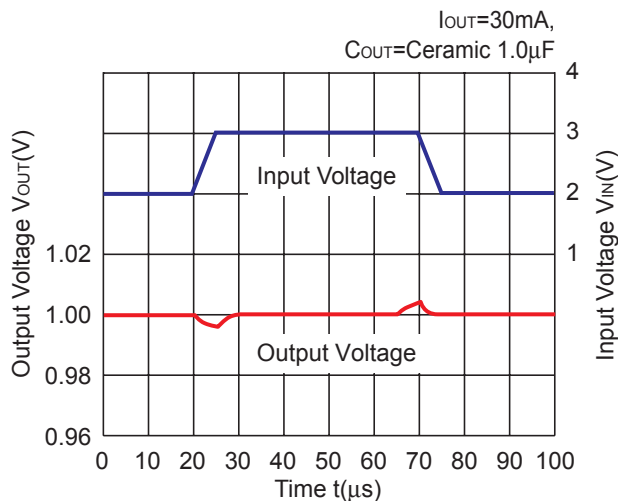

R1131x26xx

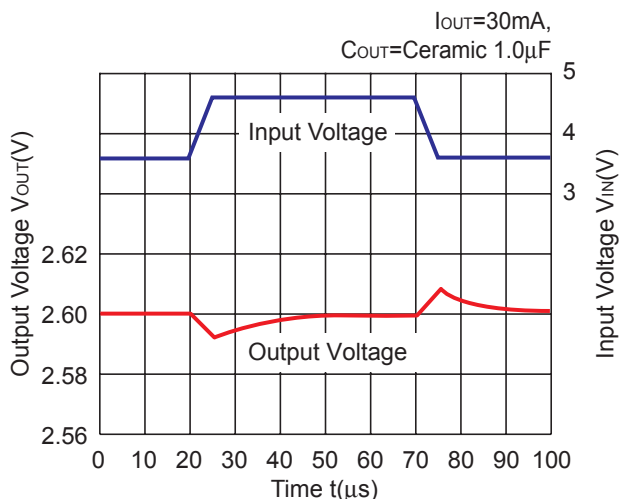

11) Load Transient Response ($tr=tf=0.5\mu s$)

R1131x08xx

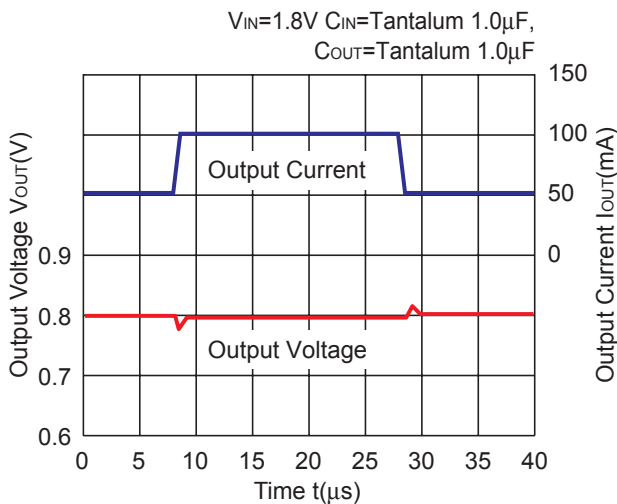

R1131x08xx

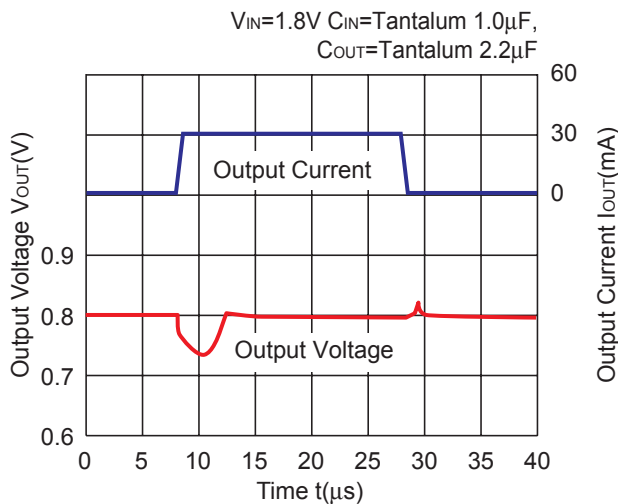

R1131x10xx

$V_{IN}=2.0V$ C_{IN} =Ceramic $1.0\mu F$,
 C_{OUT} =Ceramic $1.0\mu F$

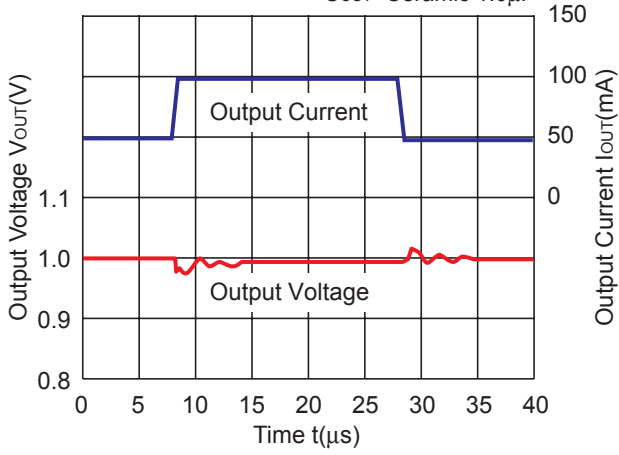

R1131x10xx

$V_{IN}=2.0V$ C_{IN} =Ceramic $1.0\mu F$,
 C_{OUT} =Ceramic $2.2\mu F$

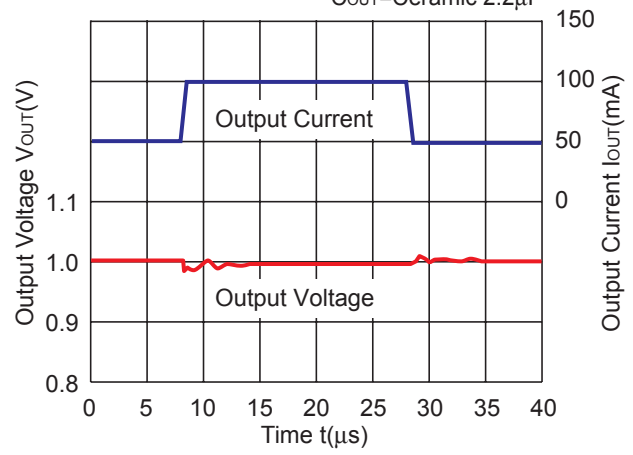

R1131x10xx

$V_{IN}=2.0V$ C_{IN} =Ceramic $1.0\mu F$,
 C_{OUT} =Ceramic $1.0\mu F$

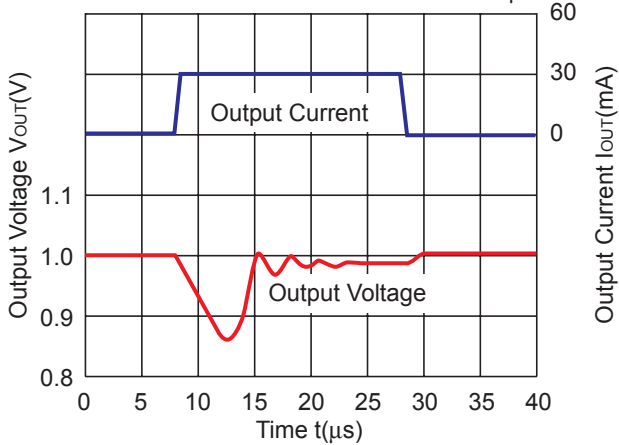

R1131x10xx

$V_{IN}=2.0V$ C_{IN} =Ceramic $1.0\mu F$,
 C_{OUT} =Ceramic $2.2\mu F$

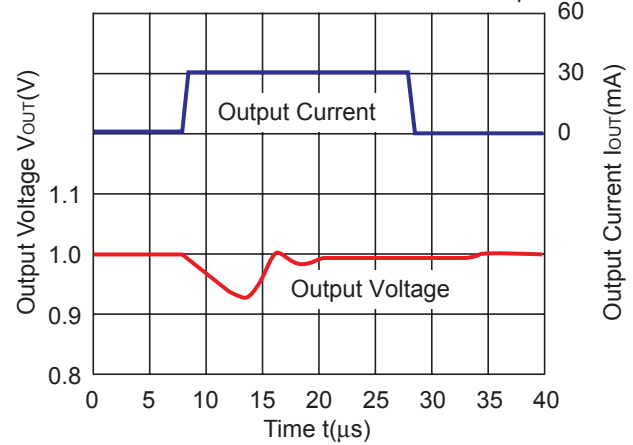

R1131x26xx

$V_{IN}=3.6V$ C_{IN} =Ceramic $1.0\mu F$,
 C_{OUT} =Ceramic $1.0\mu F$

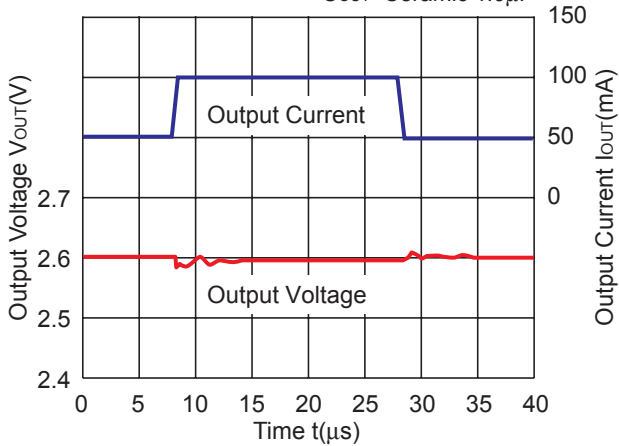

R1131x26xx

$V_{IN}=3.6V$ C_{IN} =Ceramic $1.0\mu F$,
 C_{OUT} =Ceramic $2.2\mu F$

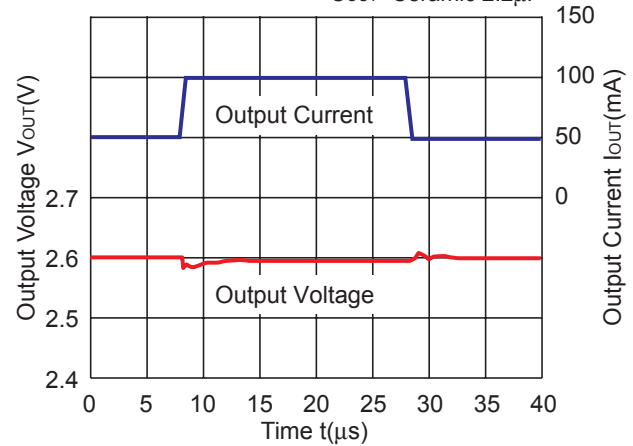

R1131x26xx

$V_{IN}=3.6V$ $C_{IN}=\text{Ceramic } 1.0\mu F$,
 $C_{OUT}=\text{Ceramic } 1.0\mu F$

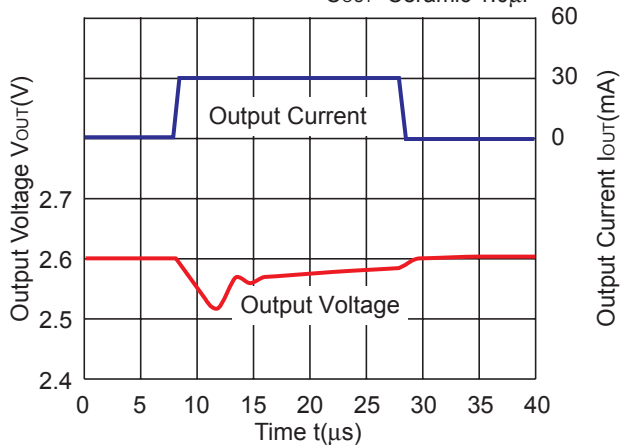

R1131x26xx

$V_{IN}=3.6V$ $C_{IN}=\text{Ceramic } 1.0\mu F$,
 $C_{OUT}=\text{Ceramic } 2.2\mu F$

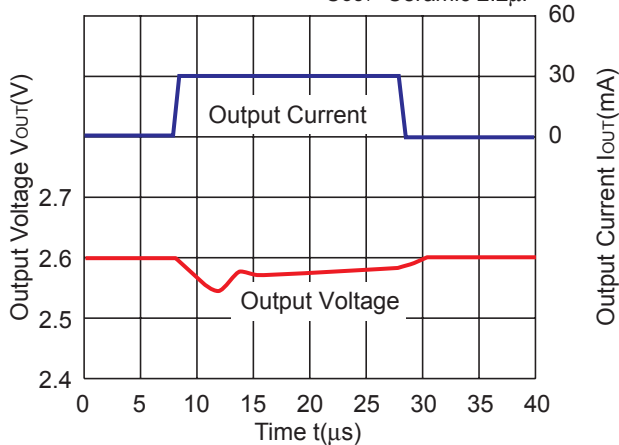

12) Turn on speed with CE pin

R1131x08xx

$V_{IN}=1.8V$ $C_{IN}=\text{Tantalum } 1.0\mu F$,
 $C_{OUT}=\text{Tantalum } 1.0\mu F$

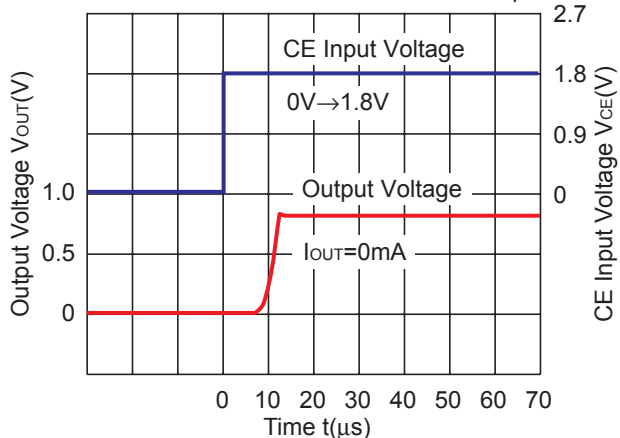

R1131x08xx

$V_{IN}=1.8V$ $C_{IN}=\text{Tantalum } 1.0\mu F$,
 $C_{OUT}=\text{Tantalum } 1.0\mu F$

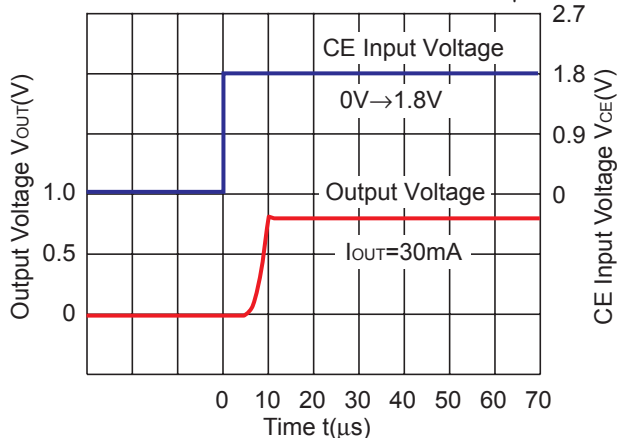

R1131x08xx

$V_{IN}=1.8V$ $C_{IN}=\text{Tantalum } 1.0\mu F$,
 $C_{OUT}=\text{Tantalum } 1.0\mu F$

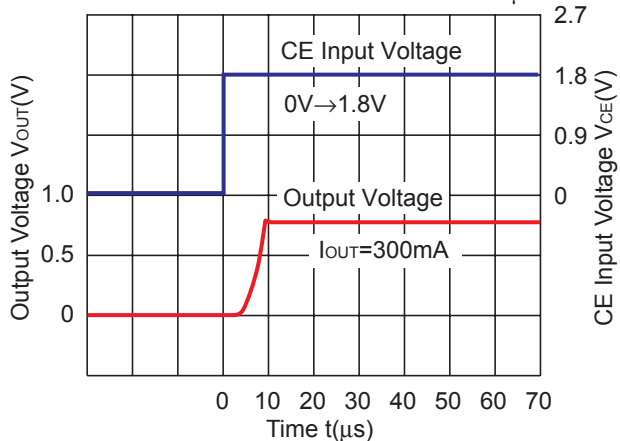

R1131x33xx

$V_{IN}=4.3V$ $C_{IN}=\text{Ceramic } 1.0\mu F$,
 $C_{OUT}=\text{Ceramic } 1.0\mu F$

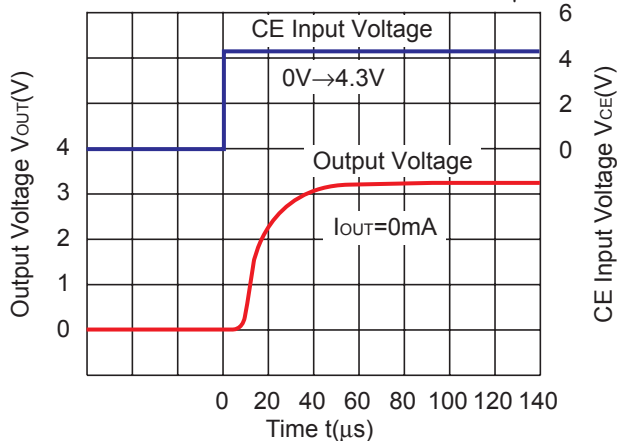

R1131x33xx (ECO=H)

$V_{IN}=4.3V$ C_{IN} =Ceramic $1.0\mu F$,
 C_{OUT} =Ceramic $1.0\mu F$

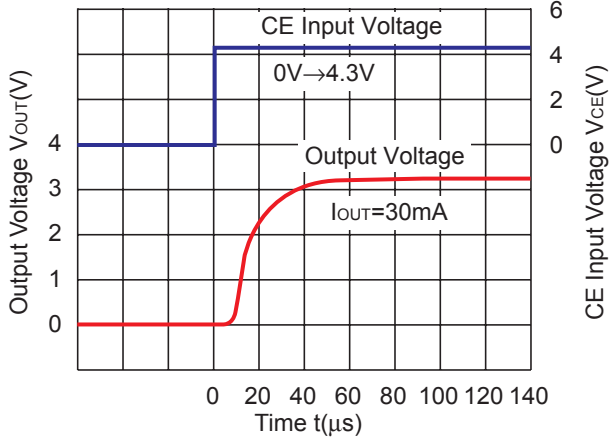

R1131x33xx (ECO=L)

$V_{IN}=4.3V$ C_{IN} =Ceramic $1.0\mu F$,
 C_{OUT} =Ceramic $1.0\mu F$

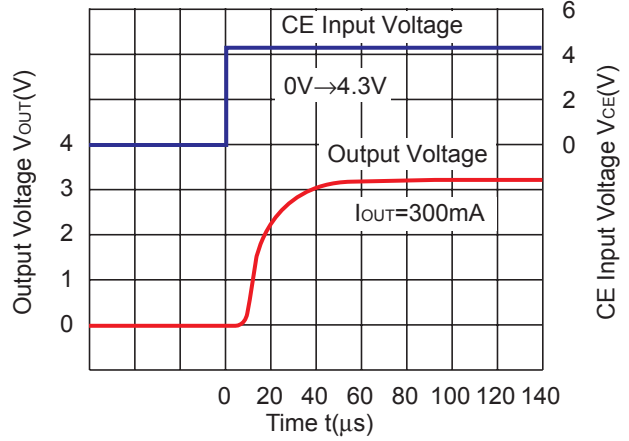

13) Turn-off Speed with CE

R1131x08xD

$V_{IN}=1.8V$ C_{IN} =Tantalum $1.0\mu F$,
 C_{OUT} =Tantalum $1.0\mu F$

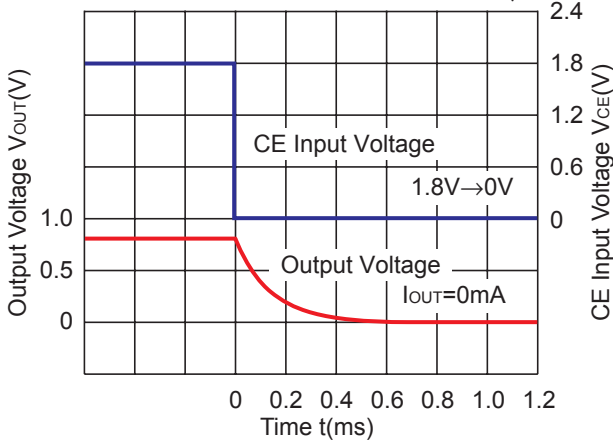

R1131x08xD

$V_{IN}=1.8V$ C_{IN} =Tantalum $1.0\mu F$,
 C_{OUT} =Tantalum $1.0\mu F$

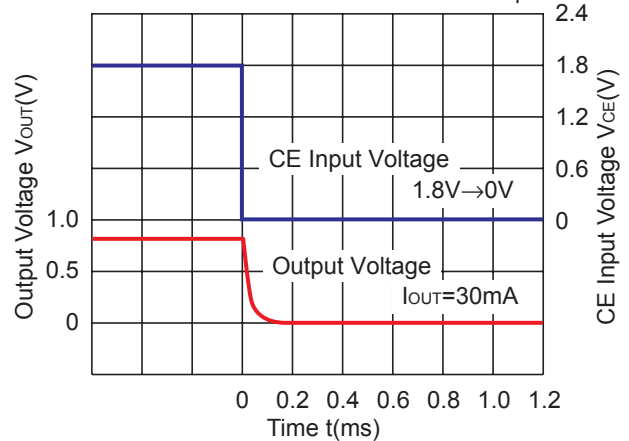

R1131x08xD

$V_{IN}=1.8V$ C_{IN} =Tantalum $1.0\mu F$,
 C_{OUT} =Tantalum $1.0\mu F$

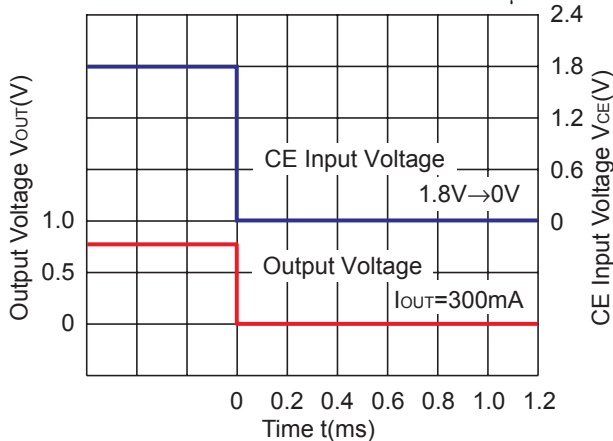

R1131x33xD

$V_{IN}=4.3V$ C_{IN} =Ceramic $1.0\mu F$,
 C_{OUT} =Ceramic $1.0\mu F$

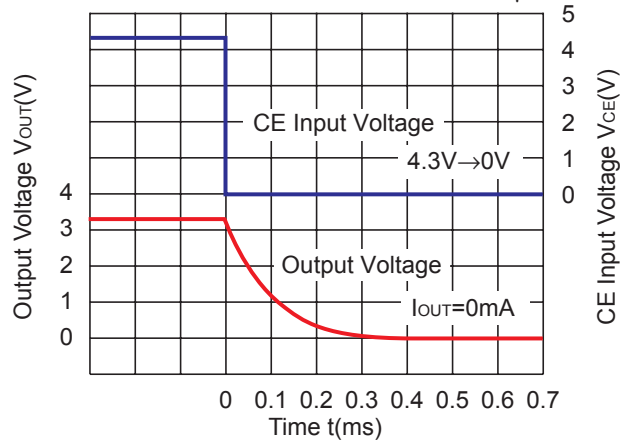

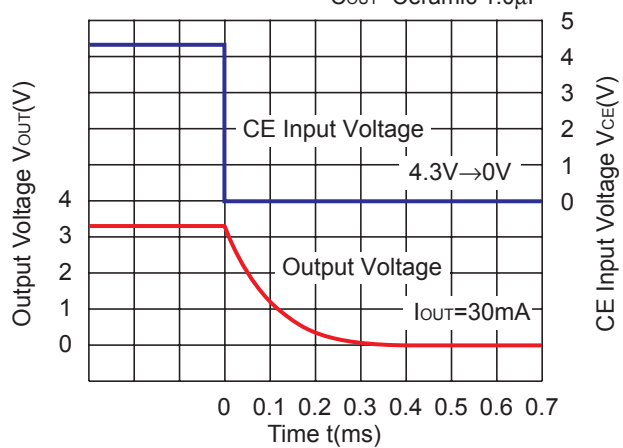
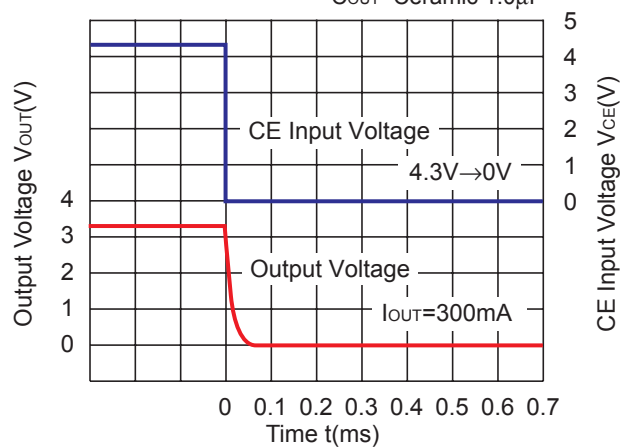
R1131x33xD $V_{IN}=4.3V$ $C_{IN}=\text{Ceramic } 1.0\mu\text{F}$,
 $C_{OUT}=\text{Ceramic } 1.0\mu\text{F}$ **R1131x33xD** $V_{IN}=4.3V$ $C_{IN}=\text{Ceramic } 1.0\mu\text{F}$,
 $C_{OUT}=\text{Ceramic } 1.0\mu\text{F}$ 

ESR vs. Output Current

When using these ICs, consider the following points:

In these ICs, phase compensation is made for securing stable operation even if the load current is varied. For this purpose, be sure to use a capacitor C_{OUT} with good frequency characteristics and ESR (Equivalent Series Resistance) of which is in the range described as follows:

The relations between I_{OUT} (Output Current) and ESR of Output Capacitor are shown below.

The conditions when the white noise level is under $40\mu V(Avg.)$ are marked as the hatched area in the graph.

<Test conditions>

- (1) Frequency band: 10Hz to 2MHz
- (2) Temperature: 25°C

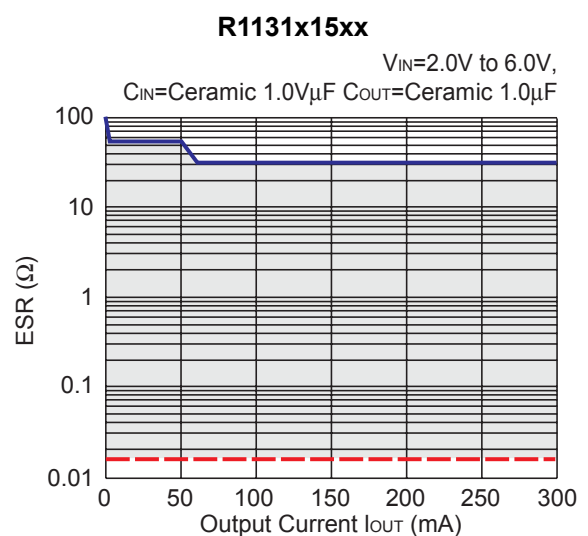
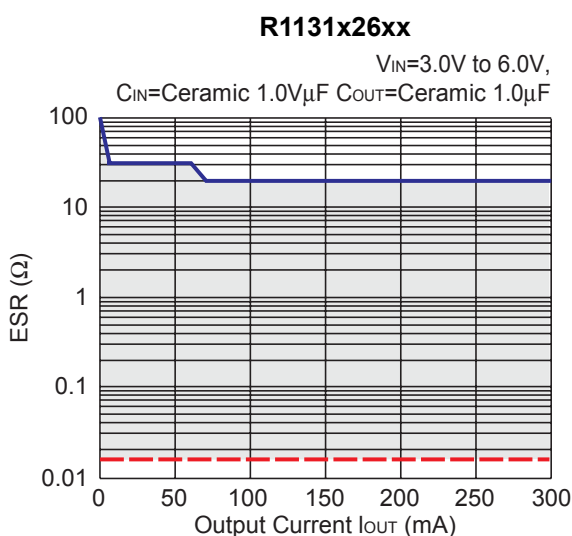
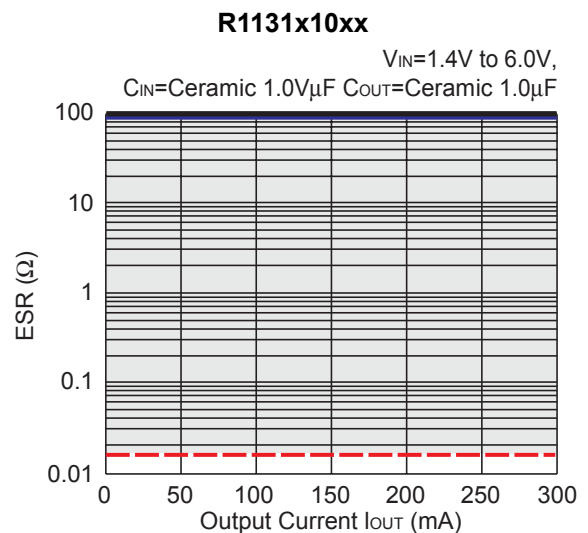
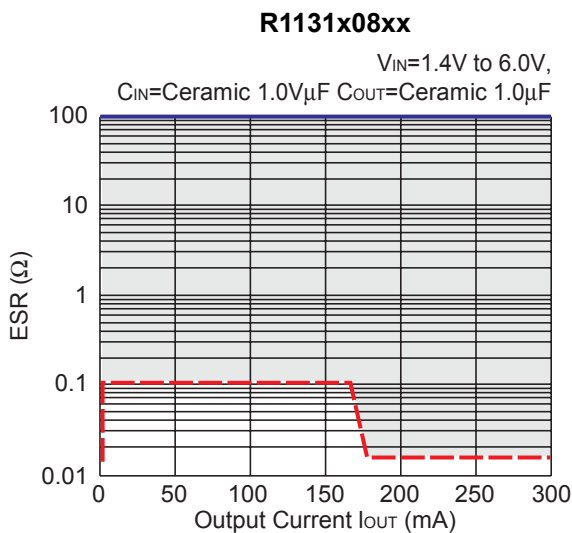

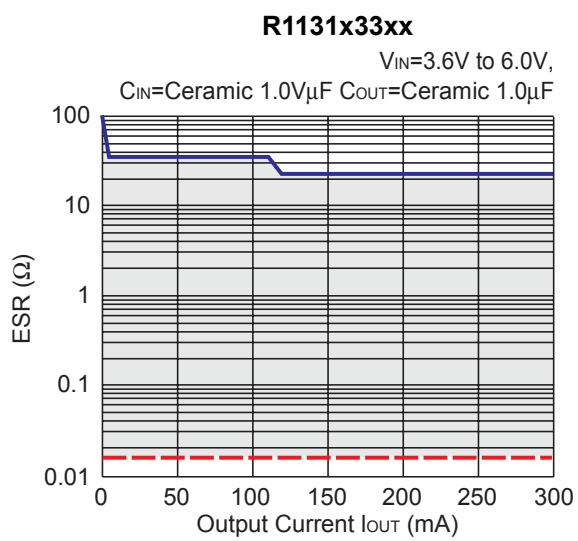

• SON-6

Unit: mm

PACKAGE DIMENSIONS

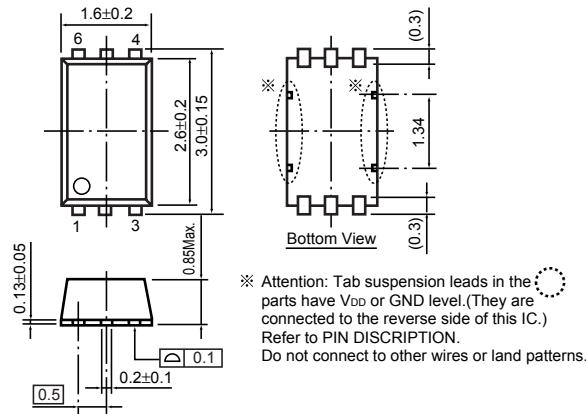

TAPING SPECIFICATION

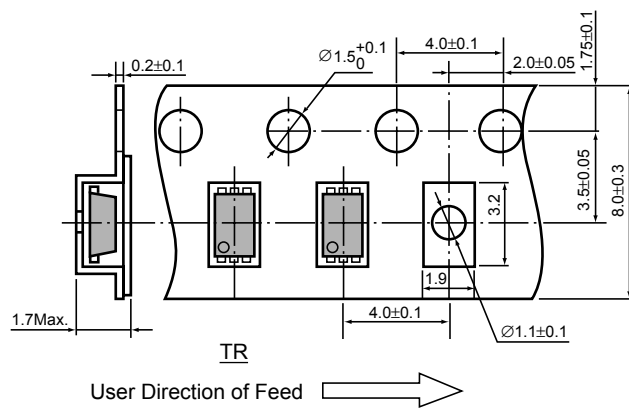

TAPING REEL DIMENSIONS REUSE REEL (EIAJ-RRM-08Bc)

(1reel=3000pcs)

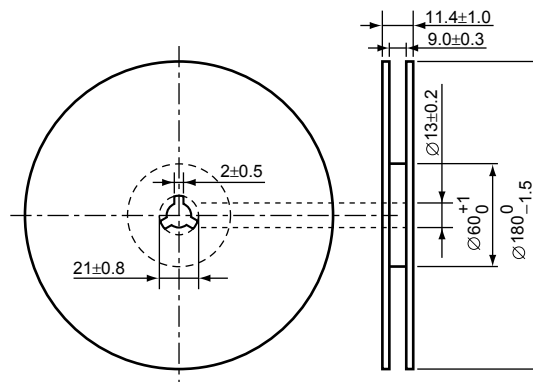

POWER DISSIPATION (SON-6)

This specification is at mounted on board. Power Dissipation (P_D) depends on conditions of mounting on board. This specification is based on the measurement at the condition below:

Measurement Conditions

	Standard Land Pattern
Environment	Mounting on Board (Wind velocity=0m/s)
Board Material	Glass cloth epoxy plactic (Double sided)
Board Dimensions	40mm × 40mm × 1.6mm
Copper Ratio	Top side : Approx. 50% , Back side : Approx. 50%
Through-hole	φ0.5mm × 44pcs

Measurement Result

($T_{opt}=25^{\circ}C, T_{jmax}=125^{\circ}C$)

	Standard Land Pattern	Free Air
Power Dissipation	500mW	250mW
Thermal Resistance	$\theta_{ja}=(125-25^{\circ}C)/0.5W=200^{\circ}C/W$	-

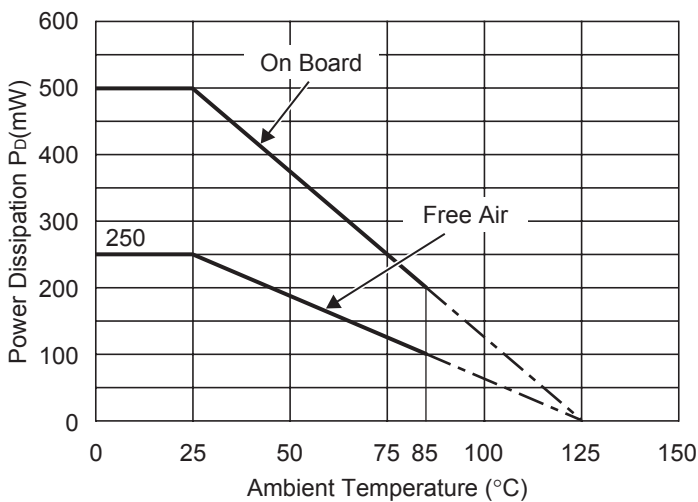

Power Dissipation

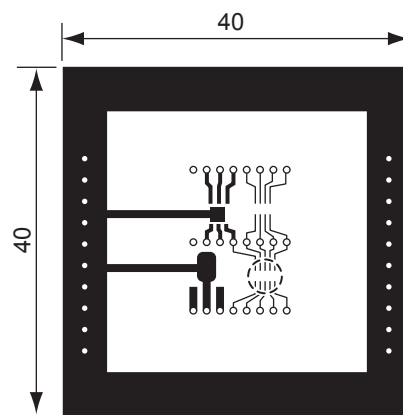

Measurement Board Pattern

○ IC Mount Area (Unit : mm)

RECOMMENDED LAND PATTERN

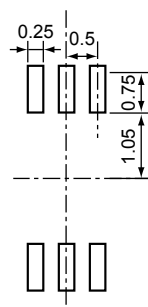

(Unit: mm)

• HSON-6

Unit: mm

PACKAGE DIMENSIONS

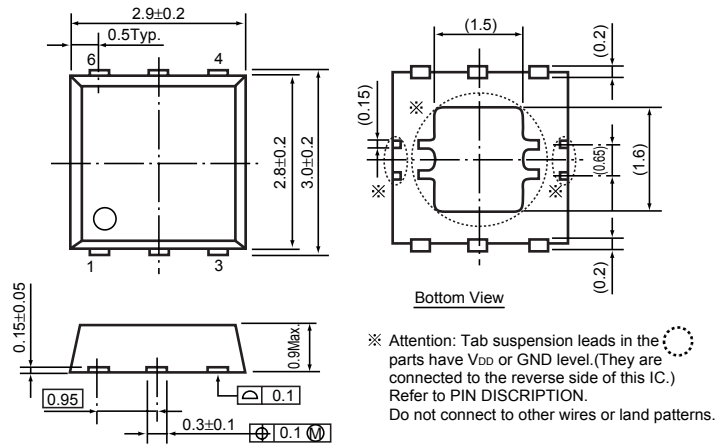

TAPING SPECIFICATION

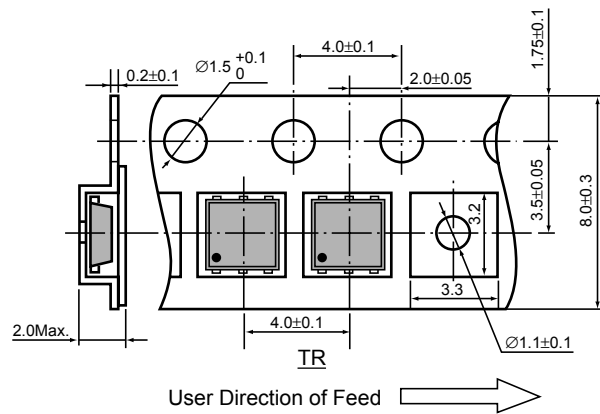

TAPING REEL DIMENSIONS REUSE REEL (EIAJ-RRM-08Bc)

(1reel=3000pcs)

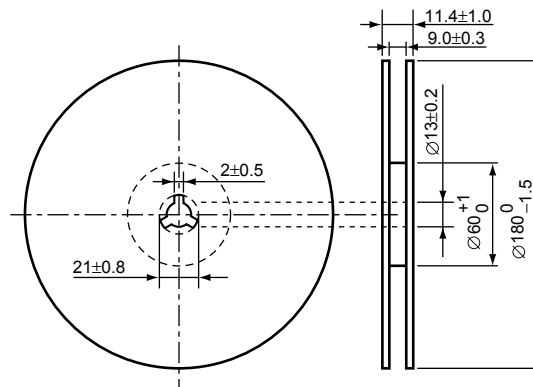

POWER DISSIPATION (HSON-6)

This specification is at mounted on board. Power Dissipation (P_D) depends on conditions of mounting on board. This specification is based on the measurement at the condition below:

Measurement Conditions

	Standard Land Pattern
Environment	Mounting on Board (Wind velocity=0m/s)
Board Material	Glass cloth epoxy plactic (Double sided)
Board Dimensions	40mm × 40mm × 1.6mm
Copper Ratio	Top side : Approx. 50% , Back side : Approx. 50%
Through-hole	φ0.5mm × 44pcs

Measurement Result

($T_{opt}=25^{\circ}C, T_{jmax}=125^{\circ}C$)

	Standard Land Pattern	Free Air
Power Dissipation	900mW	400mW
Thermal Resistance	$\theta_{ja}=(125-25^{\circ}C)/0.9W=111^{\circ}C/W$	250°C/W

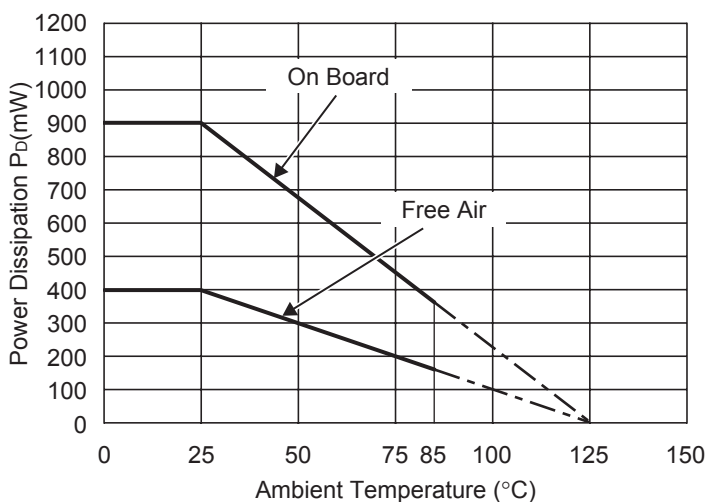

Power Dissipation

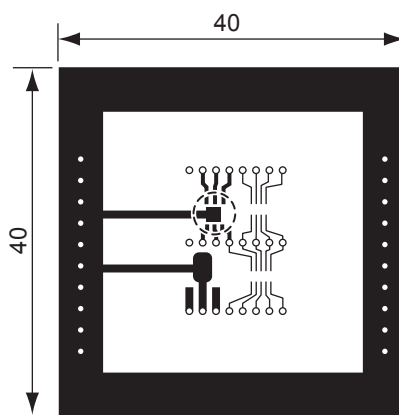

Measurement Board Pattern

○ IC Mount Area Unit : mm

RECOMMENDED LAND PATTERN

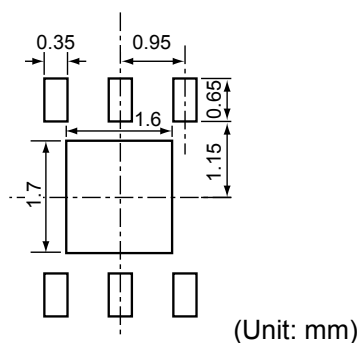

- SOT-23-5 (SC-74A)

Unit: mm

PACKAGE DIMENSIONS

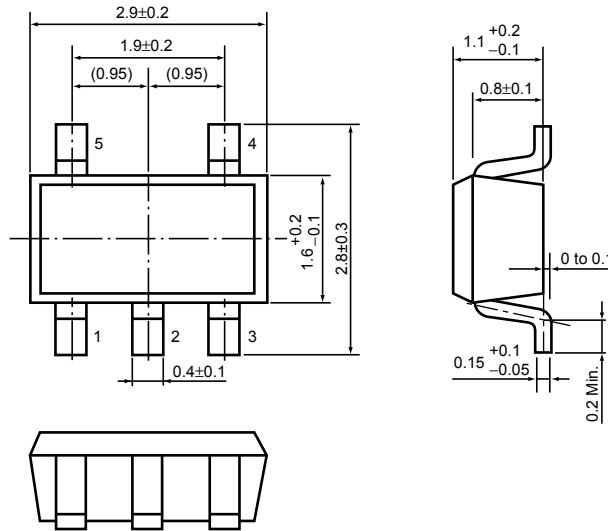

TAPING SPECIFICATION

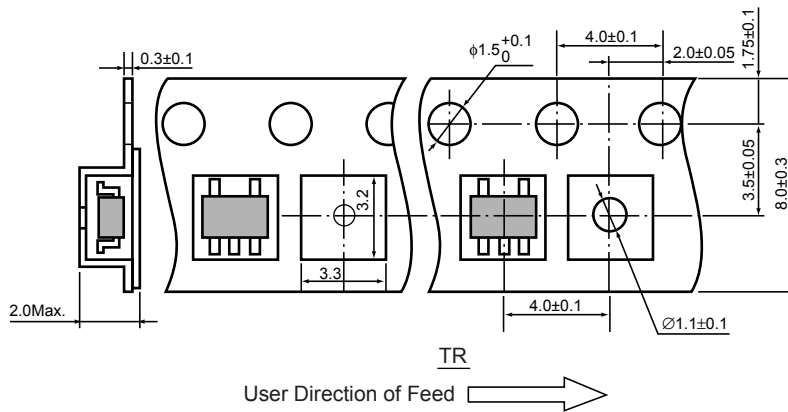

TAPING REEL DIMENSIONS REUSE REEL (EIAJ-RRM-08Bc)

(1reel=3000pcs)

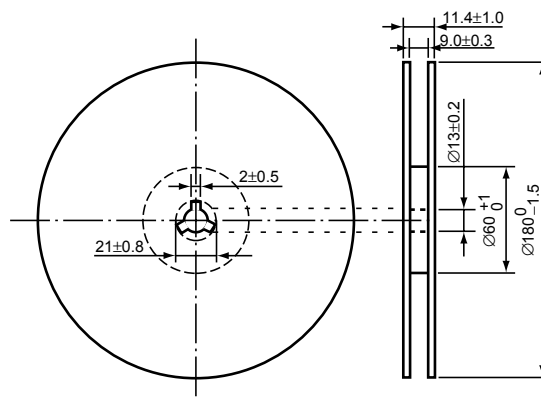

POWER DISSIPATION (SOT-23-5)

This specification is at mounted on board. Power Dissipation (P_D) depends on conditions of mounting on board.

This specification is based on the measurement at the condition below:

(Power Dissipation (SOT-23-5) is substitution of SOT-23-6.)

Measurement Conditions

	Standard Land Pattern
Environment	Mounting on Board (Wind velocity=0m/s)
Board Material	Glass cloth epoxy plactic (Double sided)
Board Dimensions	40mm × 40mm × 1.6mm
Copper Ratio	Top side : Approx. 50% , Back side : Approx. 50%
Through-hole	φ0.5mm × 44pcs

Measurement Result

($T_{opt}=25^{\circ}\text{C}$, $T_{jmax}=125^{\circ}\text{C}$)

	Standard Land Pattern	Free Air
Power Dissipation	420mW	250mW
Thermal Resistance	$\theta_{ja}=(125-25^{\circ}\text{C})/0.42\text{W}=263^{\circ}\text{C/W}$	400 $^{\circ}\text{C/W}$

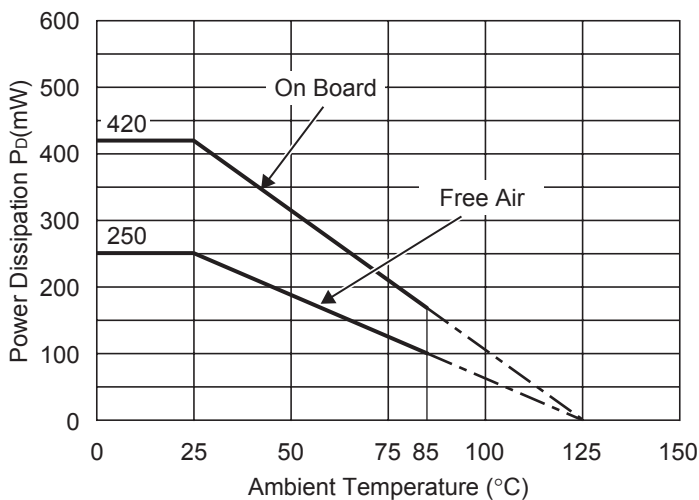

Power Dissipation

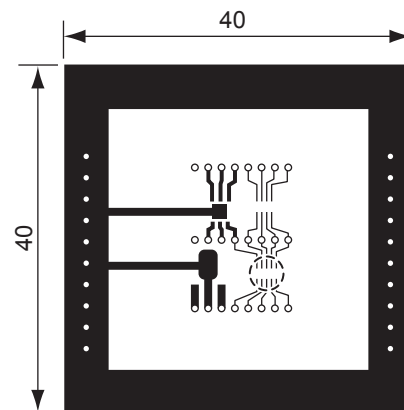

Measurement Board Pattern

○ IC Mount Area Unit : mm

RECOMMENDED LAND PATTERN

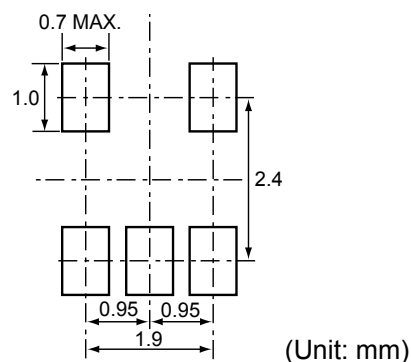

R1131Dxx1x SERIES MARK SPECIFICATION

• SON-6

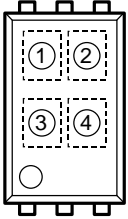

①, ② : Product Code (refer to Part Number vs. Product Code)

③, ④ : Lot Number

• Part Number vs. Product Code

Part Number	Product Code	
	①	②
R1131D081A	F	8
R1131D091A	F	9
R1131D101A	G	0
R1131D111A	G	1
R1131D121A	G	2
R1131D131A	G	3
R1131D141A	G	4
R1131D151A	G	5
R1131D161A	G	6
R1131D171A	G	7
R1131D181A	G	8
R1131D191A	G	9
R1131D201A	H	0
R1131D211A	H	1
R1131D221A	H	2
R1131D231A	H	3
R1131D241A	H	4
R1131D251A	H	5
R1131D261A	H	6
R1131D271A	H	7
R1131D281A	H	8
R1131D291A	H	9
R1131D301A	J	0
R1131D311A	J	1
R1131D321A	J	2
R1131D331A	J	3
R1131D181A5	K	0
R1131D281A5	K	1
R1131D121A5	K	2

Part Number	Product Code	
	①	②
R1131D081B	L	8
R1131D091B	L	9
R1131D101B	M	0
R1131D111B	M	1
R1131D121B	M	2
R1131D131B	M	3
R1131D141B	M	4
R1131D151B	M	5
R1131D161B	M	6
R1131D171B	M	7
R1131D181B	M	8
R1131D191B	M	9
R1131D201B	N	0
R1131D211B	N	1
R1131D221B	N	2
R1131D231B	N	3
R1131D241B	N	4
R1131D251B	N	5
R1131D261B	N	6
R1131D271B	N	7
R1131D281B	N	8
R1131D291B	N	9
R1131D301B	P	0
R1131D311B	P	1
R1131D321B	P	2
R1131D331B	P	3
R1131D181B5	Q	0
R1131D281B5	Q	1
R1131D121B5	Q	2

Part Number	Product Code	
	①	②
R1131D081D	R	8
R1131D091D	R	9
R1131D101D	S	0
R1131D111D	S	1
R1131D121D	S	2
R1131D131D	S	3
R1131D141D	S	4
R1131D151D	S	5
R1131D161D	S	6
R1131D171D	S	7
R1131D181D	S	8
R1131D191D	S	9
R1131D201D	T	0
R1131D211D	T	1
R1131D221D	T	2
R1131D231D	T	3
R1131D241D	T	4
R1131D251D	T	5
R1131D261D	T	6
R1131D271D	T	7
R1131D281D	T	8
R1131D291D	T	9
R1131D301D	U	0
R1131D311D	U	1
R1131D321D	U	2
R1131D331D	U	3
R1131D181D5	V	0
R1131D281D5	V	1
R1131D121D5	V	2

R1131Dxx2 SERIES MARK SPECIFICATION

● HSON-6

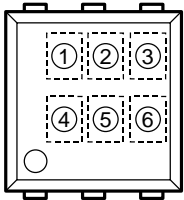

- ① : F (fixed)
- ②, ③ : Setting Voltage } (refer to Part Number vs. Product Code)
- ④ : Type (A, B,D)
- ⑤, ⑥ : Lot Number

● Part Number vs. Product Code

Part Number	Product Code			
	①	②	③	④
R1131D082A	F	0	8	A
R1131D092A	F	0	9	A
R1131D102A	F	1	0	A
R1131D112A	F	1	1	A
R1131D122A	F	1	2	A
R1131D132A	F	1	3	A
R1131D142A	F	1	4	A
R1131D152A	F	1	5	A
R1131D162A	F	1	6	A
R1131D172A	F	1	7	A
R1131D182A	F	1	8	A
R1131D192A	F	1	9	A
R1131D202A	F	2	0	A
R1131D212A	F	2	1	A
R1131D222A	F	2	2	A
R1131D232A	F	2	3	A
R1131D242A	F	2	4	A
R1131D252A	F	2	5	A
R1131D262A	F	2	6	A
R1131D272A	F	2	7	A
R1131D282A	F	2	8	A
R1131D292A	F	2	9	A
R1131D302A	F	3	0	A
R1131D312A	F	3	1	A
R1131D322A	F	3	2	A
R1131D332A	F	3	3	A
R1131D182A5	F	0	0	A
R1131D282A5	F	0	1	A
R1131D122A5	F	0	2	A

Part Number	Product Code			
	①	②	③	④
R1131D082B	F	0	8	B
R1131D092B	F	0	9	B
R1131D102B	F	1	0	B
R1131D112B	F	1	1	B
R1131D122B	F	1	2	B
R1131D132B	F	1	3	B
R1131D142B	F	1	4	B
R1131D152B	F	1	5	B
R1131D162B	F	1	6	B
R1131D172B	F	1	7	B
R1131D182B	F	1	8	B
R1131D192B	F	1	9	B
R1131D202B	F	2	0	B
R1131D212B	F	2	1	B
R1131D222B	F	2	2	B
R1131D232B	F	2	3	B
R1131D242B	F	2	4	B
R1131D252B	F	2	5	B
R1131D262B	F	2	6	B
R1131D272B	F	2	7	B
R1131D282B	F	2	8	B
R1131D292B	F	2	9	B
R1131D302B	F	3	0	B
R1131D312B	F	3	1	B
R1131D322B	F	3	2	B
R1131D332B	F	3	3	B
R1131D182B5	F	0	0	B
R1131D282B5	F	0	1	B
R1131D122B5	F	0	2	B

Part Number	Product Code			
	①	②	③	④
R1131D082D	F	0	8	D
R1131D092D	F	0	9	D
R1131D102D	F	1	0	D
R1131D112D	F	1	1	D
R1131D122D	F	1	2	D
R1131D132D	F	1	3	D
R1131D142D	F	1	4	D
R1131D152D	F	1	5	D
R1131D162D	F	1	6	D
R1131D172D	F	1	7	D
R1131D182D	F	1	8	D
R1131D192D	F	1	9	D
R1131D202D	F	2	0	D
R1131D212D	F	2	1	D
R1131D222D	F	2	2	D
R1131D232D	F	2	3	D
R1131D242D	F	2	4	D
R1131D252D	F	2	5	D
R1131D262D	F	2	6	D
R1131D272D	F	2	7	D
R1131D282D	F	2	8	D
R1131D292D	F	2	9	D
R1131D302D	F	3	0	D
R1131D312D	F	3	1	D
R1131D322D	F	3	2	D
R1131D332D	F	3	3	D
R1131D182D5	F	0	0	D
R1131D282D5	F	0	1	D
R1131D122D5	F	0	2	D

R1131N SERIES MARK SPECIFICATION

• SOT-23-5 (SC-74A)

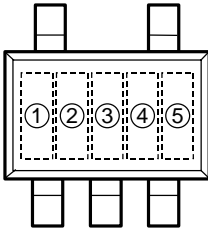

①, ②, ③ : Product Code (refer to Part Number vs. Product Code)

④, ⑤ : Lot Number

• Part Number vs. Product Code

Part Number	Product Code		
	①	②	③
R1131N081A	X	0	8
R1131N091A	X	0	9
R1131N101A	X	1	0
R1131N111A	X	1	1
R1131N121A	X	1	2
R1131N131A	X	1	3
R1131N141A	X	1	4
R1131N151A	X	1	5
R1131N161A	X	1	6
R1131N171A	X	1	7
R1131N181A	X	1	8
R1131N191A	X	1	9
R1131N201A	X	2	0
R1131N211A	X	2	1
R1131N221A	X	2	2
R1131N231A	X	2	3
R1131N241A	X	2	4
R1131N251A	X	2	5
R1131N261A	X	2	6
R1131N271A	X	2	7
R1131N281A	X	2	8
R1131N291A	X	2	9
R1131N301A	X	3	0
R1131N311A	X	3	1
R1131N321A	X	3	2
R1131N331A	X	3	3
R1131N181A5	X	0	0
R1131N281A5	X	0	1
R1131N121A5	X	0	2

Part Number	Product Code		
	①	②	③
R1131N081B	Y	0	8
R1131N091B	Y	0	9
R1131N101B	Y	1	0
R1131N111B	Y	1	1
R1131N121B	Y	1	2
R1131N131B	Y	1	3
R1131N141B	Y	1	4
R1131N151B	Y	1	5
R1131N161B	Y	1	6
R1131N171B	Y	1	7
R1131N181B	Y	1	8
R1131N191B	Y	1	9
R1131N201B	Y	2	0
R1131N211B	Y	2	1
R1131N221B	Y	2	2
R1131N231B	Y	2	3
R1131N241B	Y	2	4
R1131N251B	Y	2	5
R1131N261B	Y	2	6
R1131N271B	Y	2	7
R1131N281B	Y	2	8
R1131N291B	Y	2	9
R1131N301B	Y	3	0
R1131N311B	Y	3	1
R1131N321B	Y	3	2
R1131N331B	Y	3	3
R1131N181B5	Y	0	0
R1131N281B5	Y	0	1
R1131N121B5	Y	0	2

Part Number	Product Code		
	①	②	③
R1131N081D	Z	0	8
R1131N091D	Z	0	9
R1131N101D	Z	1	0
R1131N111D	Z	1	1
R1131N121D	Z	1	2
R1131N131D	Z	1	3
R1131N141D	Z	1	4
R1131N151D	Z	1	5
R1131N161D	Z	1	6
R1131N171D	Z	1	7
R1131N181D	Z	1	8
R1131N191D	Z	1	9
R1131N201D	Z	2	0
R1131N211D	Z	2	1
R1131N221D	Z	2	2
R1131N231D	Z	2	3
R1131N241D	Z	2	4
R1131N251D	Z	2	5
R1131N261D	Z	2	6
R1131N271D	Z	2	7
R1131N281D	Z	2	8
R1131N291D	Z	2	9
R1131N301D	Z	3	0
R1131N311D	Z	3	1
R1131N321D	Z	3	2
R1131N331D	Z	3	3
R1131N181D5	Z	0	0
R1131N281D5	Z	0	1
R1131N121D5	Z	0	2