

Push Switch 4.5mm-travel Push-push Type

SPED2 Series



Smooth and linear operation feeling.

- Detector
- Push**
- Slide
- Rotary
- Encoders
- Power

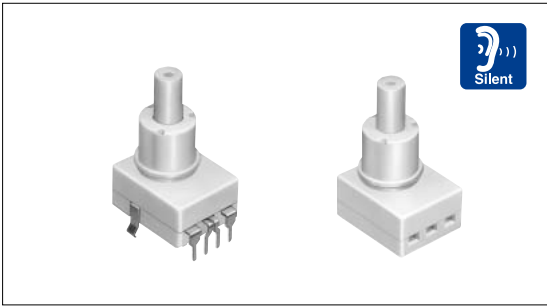

Typical Specifications

Items	Specifications
Ratings	1A 14.5V DC
Contact resistance (Initial performance)	100m max.
Operating force	4.17 ± 0.74N
Operating life(Without load)	30,000cycles
Circuit configuration	2-poles, 1-position
Travel	4.5mm

- Dual-in-line Package Type
- TACT Switch™
- Custom-Products

Product Line

Changeover timing	Travel (mm)	Total travel (mm)	Rating	Mounting method	Poles	Operation	Terminal type	Minimum order unit(pcs.)	Product No.	Drawing No.
Non shorting		4.5		PC board	2	Alternate	For PC board	1,120	SPED220200	1
				Connector				2,000	SPED210200	2

- Horizontal Type
- Vertical Type**

Dimensions









Unit:mm

No.	Style	PC board mounting dimensions (Viewed from the mounting face side)
1		
2		

Notes

1. Factory setting for contact points can be either ① or ②.
2. Please place purchase orders per minimum order unit (integer).

List of Varieties

Series	SPPH4	SPPH1	SPEC	SPED2	SPED3	SPED4	SPED5	SPEF	
Photo									
Travel (mm)	2.2	1.5	2.5					1.5	
Total travel (mm)	3	2.5	3.4	4.5	3.8		2.7		
Number of poles	2				1				
Dimensions (mm)	W	8.5	10	12	14		13.5	9.4	
	D	6.5	10		16.8	18		18.2	9
	H	8.5		12.5	26.7	20.7		6.9	
Operating temperature range	- 10°C to + 60°C		- 40°C to + 85°C						
Rating (max.) (Resistive load)	0.1A 30V DC				1A 14.5V DC				
Rating (min.) (Resistive load)	50μA 3V DC								
Electrical performance	Initial contact resistance	100m max.	20m max.	30m max.	100m max.				
	Insulation resistance	100M min. 500V DC			3M min. 500V DC			3M min. 100VDC	
	Voltage proof	500V AC for 1minute			100V AC for 1minute				
Mechanical performance	Terminal strength	5N for 1minute		3N for 1minute					
	Actuator strength	Operating direction	30N	50N				90N	
Pulling direction		10N	50N					30N	
Durability	Operating life without load	10,000cycles 100m max.	10,000cycles 40m max.	10,000cycles 50m max.	30,000cycles 100m max.				
	Operating life without load Load:as rating								
Environmental performance	Cold	-20 ± 2 for 96h			-40 ± 2 for 96h				
	Dry heat	85 ± 2 for 96h							
	Damp heat	40 ± 2 , 90 to 95%RH for 96h							
Soldering	Manual soldering	350 ± 10 3 ⁺¹ 0s			350 ± 10 3 ± 0.5s	3	350 ± 10 3 ± 0.5s	350 ± 5 3s max.	
	Dip soldering	260 ± 5 5 ± 1s	260 ± 5 10 ± 1s	260 max. 5s max.	260 ± 5 10 ± 1s	3	260 ± 5 10 ± 1s	260 ± 5 10 ± 1s 4	
	Reflow soldering								Please see P.108
Page	98	99	101	102	103		105		

Detector

Push

Slide

Rotary

Encoders

Power

Dual-in-line
Package Type

TACT Switch™

Custom-
Products

Horizontal
Type

Vertical
Type

Push Switches Attached Parts107
 Push Switches Products Caution109

Notes

3. Applicable to SPED220200(PC board type)only.
4. Applicable to SPEF110100 only.