

10GBASE-SR XFP Optical Transceiver

JXP Series



Key Features

- 850 nm VCSEL for up to 300 m reach over MMF
- Positive power supply operation (1.8 V, 3.3 V, 5.0 V)
- Power dissipation 2.0 W max
- Power-down capability to less than 50 mW
- Supports data rates from 9.95 Gb/s to 11.10 Gb/s
- XFI AC-coupled electrical interface
- Digital Diagnostic Monitoring (DDM) support
- Integrated electrical equalization on transceiver transmit side
- Integration Clock and Data Recovery (CDR) for receive and transmit data path
- No reference clock needed for JXP-01SGAA1
- Bail latch for easy removal
- Bit error rate $<10^{-12}$

Applications

- Storage Area Networks (SAN)
- Ethernet switches and applications
- Fibre channel switches and applications
- Local Area Networks (LAN)
- Client/Server environments

Compliance

- IEEE 802.3ae standard
- 10 GFC 1200-MX-SN-I standard
- Class 1 Laser Safety
- UL and TUV certified
- Tested in accordance with Telcordia GR-468

The JXP Series 10 Gb/s 850 nm XFP Transceiver is an integrated fiberoptic transceiver that provides a high-speed serial link at signaling rates from 9.95 Gb/s to 11.10 Gb/s. The module complies with IEEE 802.3ae 10GBASE-SR (Ethernet) and 10 GFC 1200-MX-SN-I (Fibre Channel) standards, as well as with the XFP Transceiver Multisource Agreement (MSA). The 10 Gb/s 850 nm XFP Transceiver is protocol-agnostic and can be used for Ethernet or Fibre Channel systems, thereby lowering customer inventory requirements and costs.

The 10 Gb/s 850 nm XFP Transceiver integrates receive and transmit paths in one package and is designed for reliability and performance. On the transmit side, the 10 Gb/s serial data stream is recovered, retimed, and passed to a laser driver. The laser driver biases and modulates an 850 nm VCSEL, enabling data transmission at distances of up to 300 m over multimode fiber (MMF) through an industry standard LC connector. On the receive side, the 10 Gb/s optical data stream is recovered from a PIN photodetector/transimpedance amplifier, retimed, and passed to an output driver. This module features a hot-pluggable XFI compliant electrical interface.

2

JXP-01SGAA1 Module Block Diagram

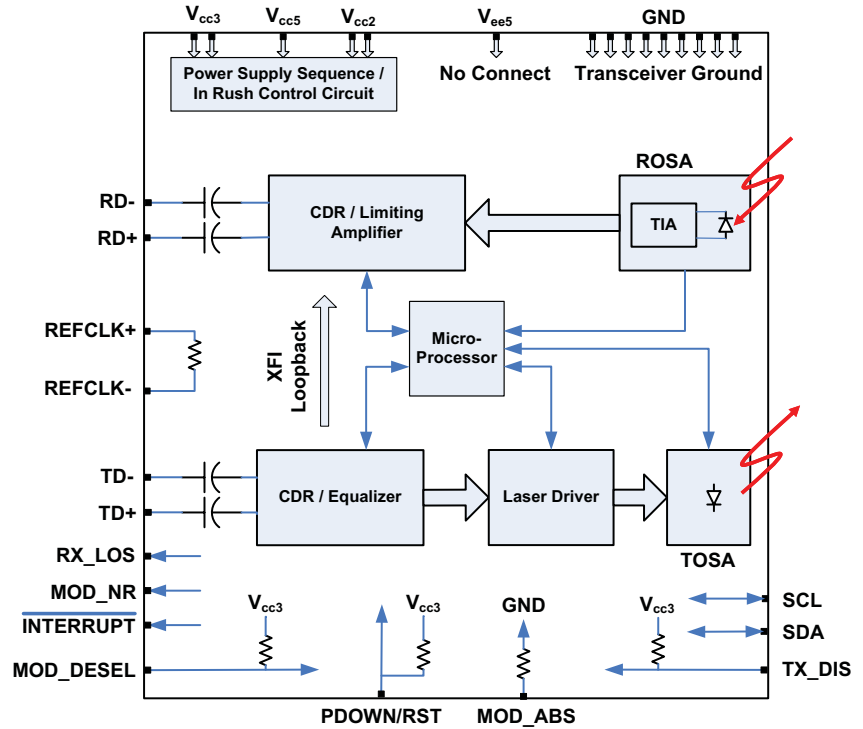

JXP-01SWAA1 Module Block Diagram

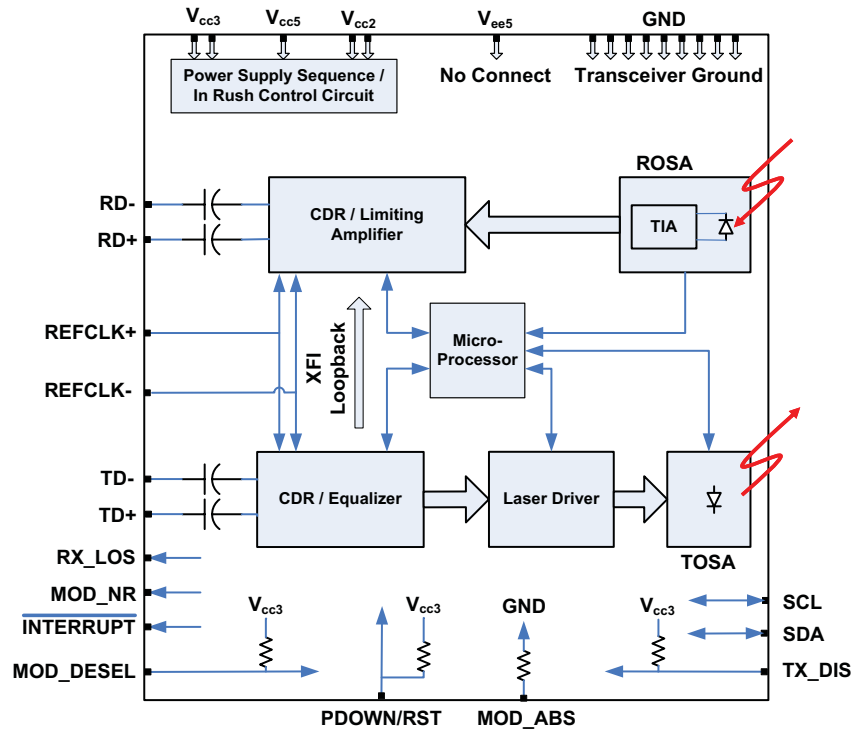

3

Specifications

Parameter		JXP-01SWAA1	JXP-01SGAA1
Electrical Interface			
Transmit signal input differential swing		120/820 mV _{P-P}	120/820 mV _{P-P}
Receive signal input differential swing		340/850 mV _{P-P}	340/850 mV _{P-P}
Control I/O signals		Low voltage TTL (3.3 V)	Low voltage TTL (3.3 V)
External reference clock		Yes	No
Optical			
Wavelength		850 nm	850 nm
Data rate		9.95 to 11.10 Gb/s	9.95 to 11.10 Gb/s
Minimum launch power into fiber (average)		-7.3 dBm	-7.3 dBm
Maximum launch power into fiber (average)		-1.0 dBm	-1.0 dBm
Transmitter and dispersion penalty (TDP)	Maximum	3.9 dB	3.9 dB
Stressed receiver sensitivity (OMA)	Maximum	-7.5 dBm	-7.5 dBm
Maximum bit error rate at minimum receiver sensitivity		<10 ⁻¹²	<10 ⁻¹²
Power			
Transceiver power	Maximum	2.0 W	2.0 W
Voltage		1.8 V, 3.3 V, 5.0 V	1.8 V, 3.3 V, 5.0 V
Voltage tolerance		±5%	±5%
Current	Typical	530 mA (1.8 V), 110 mA (3.3 V), 60 mA (5.0 V)	
Environmental			
Operating temperature, ambient		0 to 55 °C	0 to 55 °C
Operating temperature, case	Maximum	70 °C	70 °C
Operating humidity		8 to 80%	8 to 80%
Storage temperature		-40 to 85 °C	-40 to 85 °C
Mechanical			
Dimensions (W x D x H)		XFP MSA compliant	XFP MSA compliant
Form factor		XFP, LC connector	XFP, LC connector
Digital Diagnostic Monitoring			
Diagnostics		XFP DDM compliant	XFP DDM compliant
Control		XFP DDM compliant	XFP DDM compliant
Serial ID (base and extended)		XFP DDM compliant	XFP DDM compliant
Laser Safety			
US		21 CFR 1040.10 except for deviations pursuant to Laser Notice 50 (2001); UL approved for US and Canada	
International		IEC 60825:Am.2 (2001) and IEC 60950 (CB Scheme)	

Ordering Information

For more information on this or other products and their availability, please contact your local JDSU account manager or JDSU directly at 1-800-498-JDSU (5378) in North America and +800-5378-JDSU worldwide or via e-mail at customer.service@jdsu.com.

Sample: JXP-01SGAA1

Product Code	Description
JXP-01SGAA1	10GBASE-SR XFP Optical Transceiver without External Reference Clock
JXP-01SWAA1	10GBASE-SR XFP Optical Transceiver with External Reference Clock

Telcordia is a registered trademark of Telcordia Technologies Incorporated.

All statements, technical information and recommendations related to the products herein are based upon information believed to be reliable or accurate. However, the accuracy or completeness thereof is not guaranteed, and no responsibility is assumed for any inaccuracies. The user assumes all risks and liability whatsoever in connection with the use of a product or its application. JDSU reserves the right to change at any time without notice the design, specifications, function, fit or form of its products described herein, including withdrawal at any time of a product offered for sale herein. JDSU makes no representations that the products herein are free from any intellectual property claims of others. Please contact JDSU for more information. JDSU and the JDSU logo are trademarks of JDS Uniphase Corporation. Other trademarks are the property of their respective holders. ©2007 JDS Uniphase Corporation. All rights reserved. 10143051 Rev.003 03/07 10GSRXFPTC.DS.CMS.AE