

**SKiiP® 3**

## 2-pack-integrated intelligent Power System

### Power section

**SKiiP 2013GB172-4DL**

Data

### Power section features

- SKiiP technology inside
- Trench IGBTs
- CAL diode technology
- Integrated current sensor
- Integrated temperature sensor
- Integrated heat sink
- IEC 60721-3-3 (humidity) class 3K3/IE32 (SKiiP® 3 System)
- IEC 60068-1 (climate) 40/125/56
- UL recognized file no. E63532

- 1) with assembly of suitable MKP capacitor per terminal
- 8) AC connection busbars must be connected by the user; copper busbars available on request

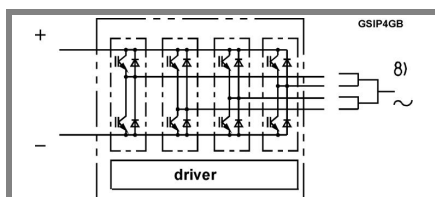

Case S43

Absolute Maximum Ratings		$T_s = 25^\circ\text{C}$ unless otherwise specified	
Symbol	Conditions	Values	Units
<b>IGBT</b>			
$V_{CES}$	Operating DC link voltage	1700	V
$V_{CC}^{1)}$		1200	V
$V_{GES}$		$\pm 20$	V
$I_C$	$T_s = 25 (70)^\circ\text{C}$	2000 (1500)	A
<b>Inverse diode</b>			
$I_F = -I_C$	$T_s = 25 (70)^\circ\text{C}$	1650 (1250)	A
$I_{FSM}$	$T_j = 150^\circ\text{C}$ , $t_p = 10\text{ ms}$ ; sin	13500	A
$I^2t$ (Diode)	Diode, $T_j = 150^\circ\text{C}$ , 10 ms	911	$\text{kA}^2\text{s}$
$T_j, (T_{stg})$		- 40 ... + 150 (125)	$^\circ\text{C}$
$V_{isol}$	rms, AC, 1 min, main terminals to heat sink	4000	V
$I_{AC-terminal}$	per AC terminal, rms, $T_s = 70^\circ\text{C}$ ,	400	A
	$T_{terminal} < 115^\circ\text{C}$		

Characteristics		$T_s = 25^\circ\text{C}$ unless otherwise specified			
Symbol	Conditions	min.	typ.	max.	Units
<b>IGBT</b>					
$V_{CEsat}$	$I_C = 1200\text{ A}$ , $T_j = 25 (125)^\circ\text{C}$ ; measured at terminal		1,9 (2,2)	2,4	V
$V_{CEO}$	$T_j = 25 (125)^\circ\text{C}$ ; at terminal		1 (0,9)	1,2 (1,1)	V
$r_{CE}$	$T_j = 25 (125)^\circ\text{C}$ ; at terminal		0,8 (1)	1 (1,3)	$\text{m}\Omega$
$I_{CES}$	$V_{GE} = 0\text{ V}$ , $V_{CE} = V_{CES}$ , $T_j = 25 (125)^\circ\text{C}$		4,8 (288)		mA
$E_{on} + E_{off}$	$I_C = 1200\text{ A}$ , $V_{CC} = 900\text{ V}$		780		mJ
	$T_j = 125^\circ\text{C}$ , $V_{CC} = 1200\text{ V}$		1150		mJ
$R_{CC+EE}$	terminal chip, $T_j = 25^\circ\text{C}$		0,13		$\text{m}\Omega$
$L_{CE}$	top, bottom		3		nH
$C_{CHC}$	per phase, AC-side		6,8		nF
<b>Inverse diode</b>					
$V_F = V_{EC}$	$I_F = 1200\text{ A}$ , $T_j = 25 (125)^\circ\text{C}$ measured at terminal		2 (1,8)	2,15	V
$V_{TO}$	$T_j = 25 (125)^\circ\text{C}$		1,1 (0,8)	1,2 (0,9)	V
$r_T$	$T_j = 25 (125)^\circ\text{C}$		0,8 (0,8)	0,8 (0,9)	$\text{m}\Omega$
$E_{rr}$	$I_C = 1200\text{ A}$ , $V_{CC} = 900\text{ V}$		144		mJ
	$T_j = 125^\circ\text{C}$ , $V_{CC} = 1200\text{ V}$		171		mJ
<b>Mechanical data</b>					
$M_{dc}$	DC terminals, SI Units	6		8	Nm
$M_{ac}$	AC terminals, SI Units	13		15	Nm
w	SKiiP® 3 System w/o heat sink		3,1		kg
w	heat sink		9,7		kg
<b>Thermal characteristics (PX 16 heat sink with fan SKF16B-230-1); "s" reference to heat sink; "r" reference to built-in temperature sensor (acc.IEC 60747-15)</b>					
$R_{th(j-s)I}$	per IGBT			0,015	K/W
$R_{th(j-s)D}$	per diode			0,029	K/W
$Z_{th}$	$R_i$ (mK/W) (max. values)	tau,(s)			
		1	2	3	4
$Z_{th(j-r)I}$		5,6	6	6,4	0
$Z_{th(j-r)D}$		10	8,4	14,8	14,8
$Z_{th(r-a)}$		3,1	17,3	3,7	0,9
				230	78
					13
					0,4

This technical information specifies semiconductor devices but promises no characteristics. No warranty or guarantee, expressed or implied is made regarding delivery, performance or suitability.

# SKiiP 2013GB172-4DL

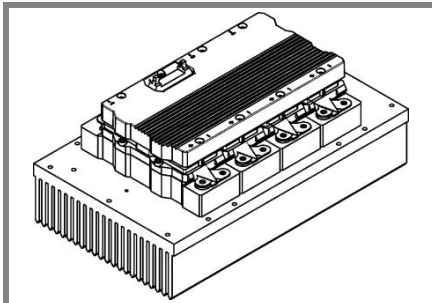

SKiiP® 3

## 2-pack-integrated intelligent Power System

2-pack  
integrated gate driver  
SKiiP 2013GB172-4DL

Data

### Gate driver features

- CMOS compatible inputs
- Wide range power supply
- Integrated circuitry to sense phase current, heat sink temperature and DC-bus voltage (option)
- Short circuit protection
- Over current protection
- Over voltage protection (option)
- Power supply protected against under voltage
- Interlock of top/bottom switch
- Isolation by transformers
- Fibre optic interface (option for GB-types only)
- IEC 60068-1 (climate) 40/85/56
- UL recognized file no. 242581

Absolute Maximum Ratings		$T_a = 25^\circ\text{C}$ unless otherwise specified	
Symbol	Conditions	Values	Units
$V_{S2}$	unstabilized 24 V power supply	30	V
$V_i$	input signal voltage (high)	15 + 0,3	V
$dv/dt$	secondary to primary side	75	kV/ $\mu\text{s}$
$V_{isolIO}$	input / output (AC, rms, 2s)	4000	V
$V_{isolPD}$	partial discharge extinction voltage, rms, $Q_{PD} \leq 10$ pC;	1500	V
$V_{isol12}$	output 1 / output 2 (AC, rms, 2s)	1500	V
$f_{sw}$	switching frequency	7	kHz
$f_{out}$	output frequency for $I_{peak(1)} = I_C$	7	kHz
$T_{op} (T_{stg})$	operating / storage temperature	- 40 ... + 85	$^\circ\text{C}$

Characteristics		$(T_a = 25^\circ\text{C})$			
Symbol	Conditions	min.	typ.	max.	Units
$V_{S2}$	supply voltage non stabilized	13	24	30	V
$I_{S2}$	$V_{S2} = 24$ V	$430 + 45 \cdot f / \text{kHz} + 0,00011 \cdot (I_{AC} / \text{A})^2$			mA
$V_{iT+}$	input threshold voltage (High)			12,3	V
$V_{iT-}$	input threshold voltage (Low)	4,6			V
$R_{IN}$	input resistance		10		k $\Omega$
$C_{IN}$	input capacitance		1		nF
$t_{d(on)IO}$	input-output turn-on propagation time		1,3		$\mu\text{s}$
$t_{d(off)IO}$	input-output turn-off propagation time		1,3		$\mu\text{s}$
$t_{pERRRESET}$	error memory reset time		9		$\mu\text{s}$
$t_{TD}$	top / bottom switch interlock time		3,3		$\mu\text{s}$
$I_{analogOUT}$	max. 5mA; 8 V corresponds to 15 V supply voltage for external components		2000		A
$I_{s1out}$	max. load current			50	mA
$I_{TRIPSC}$	over current trip level ( $I_{analog OUT} = 10$ V)		2500		A
$T_{tp}$	over temperature protection	110		120	$^\circ\text{C}$
$U_{DCTRIP}$	$U_{DC}$ -protection ( $U_{analog OUT} = 9$ V); (option for GB types)		not implemented		V

For electrical and thermal design support please use SEMISEL.  
Access to SEMISEL is via SEMIKRON website <http://www.semikron.com>.

This technical information specifies semiconductor devices but promises no characteristics. No warranty or guarantee, expressed or implied is made regarding delivery, performance or suitability.

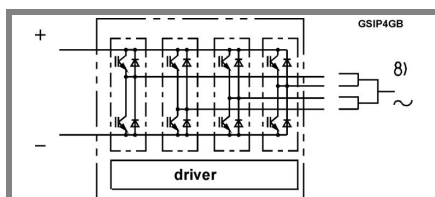

Case S43