

Features

- Typical Isolation: 36 dB (2,000 MHz)
- Typical Insertion Loss: 1.8 dB (2,000 MHz)
- Integral ASIC TTL/CMOS Driver
- Low DC Power Consumption
- 50 Ohm Nominal Impedance
- Tape and Reel Packaging Available
- Test Boards Available
- SOW-24 Package

Description

M/A-COM's SW65-0114 is a GaAs MMIC absorptive SPDT switch with an integral silicon ASIC driver. This device is in a 24-lead plastic package. This switch offers excellent broadband performance and repeatability from DC to 3 GHz, while maintaining low DC power dissipation. The SW65-0114 is ideally suited for wireless infrastructure applications. Also available in ceramic package with improved performance.

Functional Block Diagram

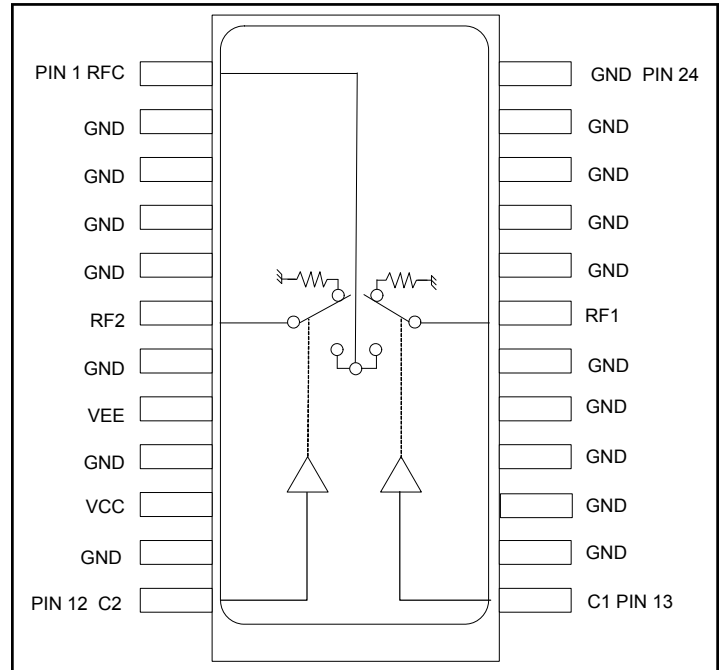

Ordering Information

Part Number	Package
SW65-0114	Bulk Packaging
SW65-0114TR	1000 piece reel
SW65-0114-TB	Sample Test Board

Note: Reference Application Note M513 for reel size information.

Pin Configuration

Pin No.	Function	Pin No.	Function
1	RFC	13	C1
2	GND	14	GND
3	GND	15	GND
4	GND	16	GND
5	GND	17	GND
6	RF2	18	GND
7	GND	19	RF1
8	V _{EE}	20	GND
9	GND	21	GND
10	V _{CC}	22	GND
11	GND	23	GND
12	C2	24	GND

Electrical Specifications: $T_A = 25^\circ\text{C}$, $Z_0 = 50\Omega$

Parameter	Test Conditions	Units	Min	Typ	Max
Insertion Loss	DC - 3.0 GHz	dB	—	1.8	2.2
Isolation (All arms off)	DC - 3.0 GHz	dB	33	36	—
VSWR	DC - 3.0 GHz On	—	—	1.7:1	2.2:1
	Off	—	—	2.1:1	2.2:1
T_{rise} T_{fall} T_{on} T_{off} Transients	10%/90%, 90%/10% ¹	ns	—	15	50
	50% TTL to 90%/10% RF	ns	—	50	150
	In-band (peak to peak)	mV	—	50	150
1 dB Compression	.05 GHz	dBm	—	+20	—
	.5 - 3.0 GHz	dBm	—	+27	—
Input IP_3	Two tone inputs 0.05 GHz	dBm	—	+35	—
	up to +5 dBm 0.5 - 3.0 GHz	dBm	—	+46	—
V_{CC}	—	V	+4.5	+5.0	+5.5
V_{EE}	—	V	-8.0	-5.0	-4.75
V_{IL} V_{IH}	LOW-level input voltage	V	0.0	—	0.8
	HIGH-level input voltage	V	2.0	—	5.0
lin (Input Leakage Current)	$V_{in} = V_{CC}$ or GND	μA	-1.0	—	1.0
I_{CC} (Quiescent Supply Current)	$V_{ctrl} = V_{CC}$ or GND	μA	—	250	400
ΔI_{CC} (Additional Supply Current Per TTL Input Pin)	$V_{CC} = \text{Max}$, $V_{ctrl} = V_{CC} - 2.1 \text{ V}$	mA	—	—	1.0
I_{EE}	V_{EE} min to max, $V_{in} = V_{IL}$ or V_{IH}	mA	-1.0	-0.2	—

1. Decoupling capacitors (.01 μF) are required on the power supply lines.

Absolute Maximum Ratings^{2,3}

Parameter	Absolute Maximum
Max. Input Power 0.05 GHz 0.5 - 3.0 GHz ⁴	+27 dBm +34 dBm
V_{CC}	$-0.5\text{V} \leq V_{CC} \leq +7.0\text{V}$
V_{EE}	$-8.5\text{V} \leq V_{EE} \leq +0.5\text{V}$
$V_{CC} - V_{EE}$	$-0.5\text{V} \leq V_{CC} - V_{EE} \leq 14.5\text{V}$
V_{in} ⁵	$-0.5\text{V} \leq V_{in} \leq V_{CC} + 0.5\text{V}$
Operating Temperature	-40°C to +85°C
Storage Temperature	-65°C to +125°C

- Exceeding any one or combination of these limits may cause permanent damage to this device.
- M/A-COM does not recommend sustained operation near these survivability limits.
- When the RF input is applied to the terminated port, the absolute maximum power is +30 dBm.
- Standard CMOS TTL interface, latch-up will occur if logic signal is applied prior to power supply.

Handling Procedures

Please observe the following precautions to avoid damage:

Static Sensitivity

Gallium Arsenide Integrated Circuits are sensitive to electrostatic discharge (ESD) and can be damaged by static electricity. Proper ESD control techniques should be used when handling these devices.

Truth Table

TTL Control Input		RF Common To:	
C1	C2	RF1	RF2
1	0	On	Off
0	1	Off	On

• North America Tel: 800.366.2266 • Europe Tel: +353.21.244.6400
 • India Tel: +91.80.4155721 • China Tel: +86.21.2407.1588
 Visit www.macomtech.com for additional data sheets and product information.

ADVANCED: Data Sheets contain information regarding a product M/A-COM Technology Solutions is considering for development. Performance is based on target specifications, simulated results, and/or prototype measurements. Commitment to develop is not guaranteed.
PRELIMINARY: Data Sheets contain information regarding a product M/A-COM Technology Solutions has under development. Performance is based on engineering tests. Specifications are typical. Mechanical outline has been fixed. Engineering samples and/or test data may be available. Commitment to produce in volume is not guaranteed.

M/A-COM Technology Solutions Inc. and its affiliates reserve the right to make changes to the product(s) or information contained herein without notice.

Typical Performance Curves

Insertion Loss vs. Frequency

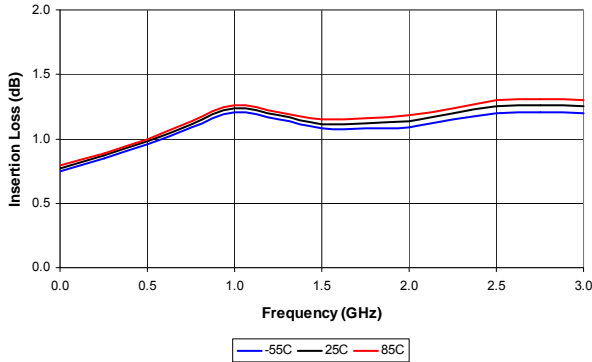

Isolation Loss vs. Frequency

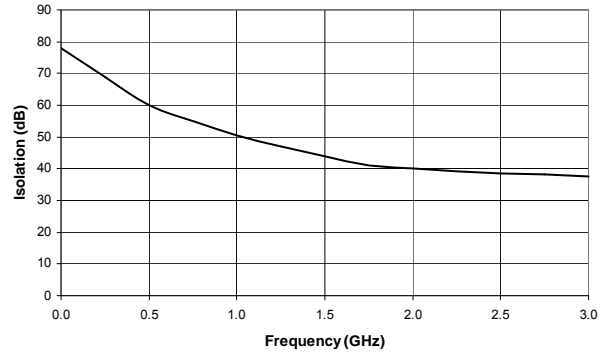

RFC VSWR vs. Frequency

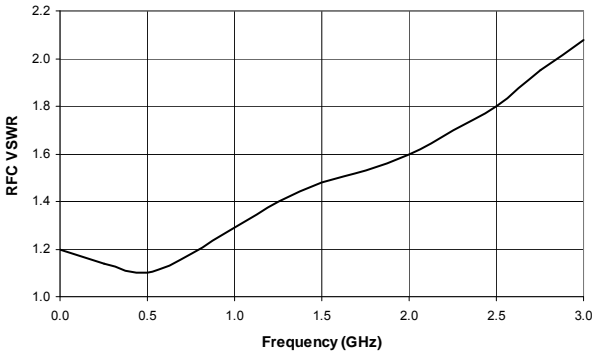

RF1-RF2 VSWR vs. Frequency

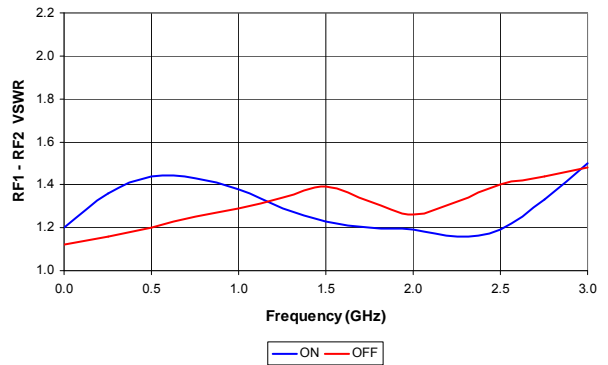

SW65-0114

GaAs SPDT Absorptive Switch with ASIC Driver, DC-3.0 GHz

Rev. V7

SOW-24†

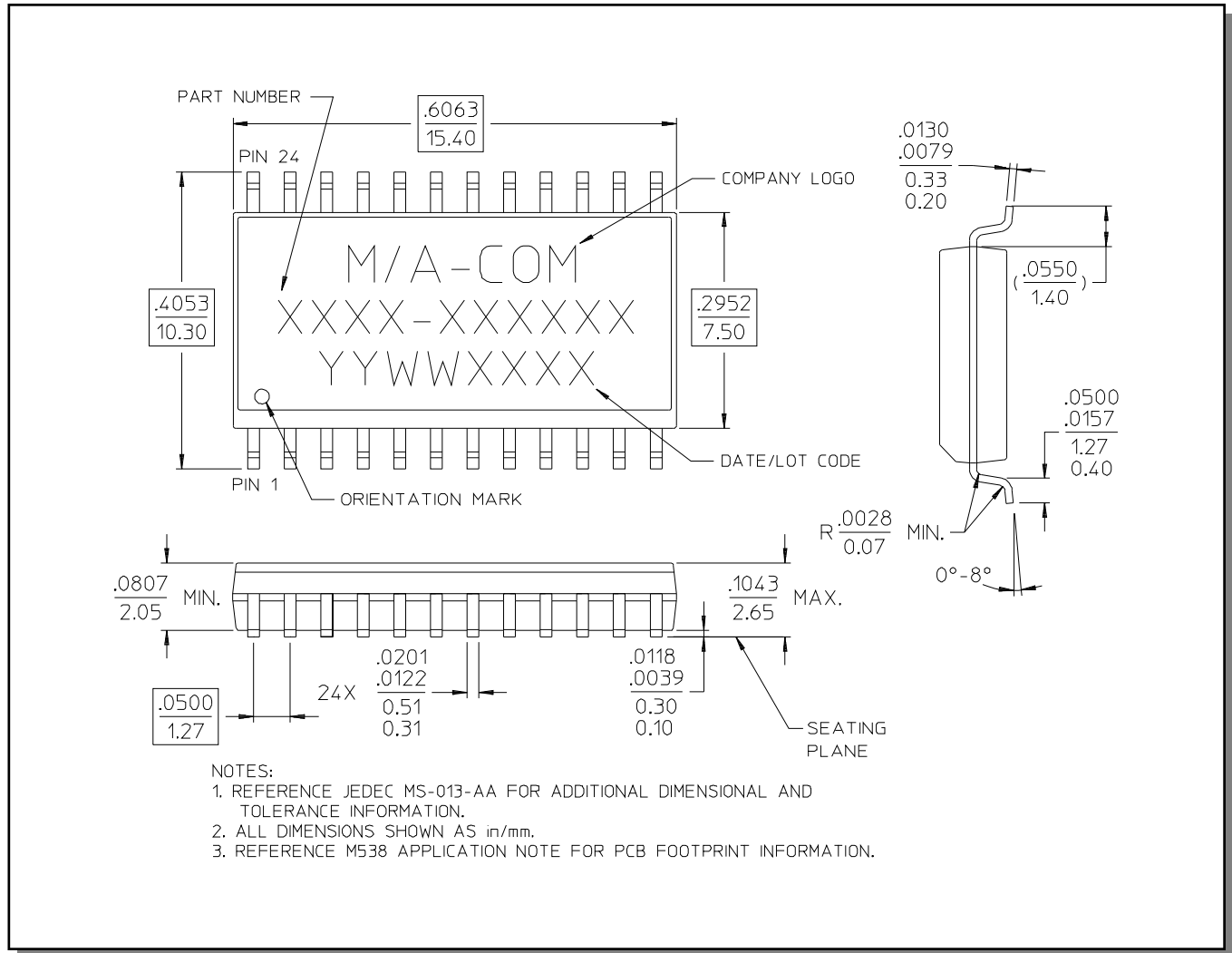

† Reference Application Note M538 for lead-free solder reflow recommendations.