

Description

GM7130 series is designed to provide all the active function for a step-down (buck) switching regulator, and drives a maximum load current as high as 3A line and load regulations. GM7130 is available in fixed output voltages of 3.3V, 5V, 12V and a versatile Adjustable output version.

These regulators are simple to use and require minimum number of external components. The features include internal frequency compensation and a fixed-frequency oscillator.

The GM7130 is high-efficiency replacements for popular three-terminal linear regulators, and is requiring a smaller heat sink or even no need heat sink.

GM7130 performs well with standard inductors from most of manufacturers, and simplifying the design of switch-mode power supplies. External shutdown is included with 80 μ A (typical) standby current. The output switch has cycle-by-cycle current limiting as well as thermal shutdown for full protection under fault conditions.

GM7130 operates at a switching frequency of 52 kHz which allowing smaller size filter components than what would be needed with lower frequency switching regulators.

GM7130 series are available in a standard 5-lead TO-220, TO220B and TO263 packages.

Features

- ◆ 3.3V, 5V, 12V and Adjustable output versions
- ◆ Adjustable version output voltage range 1.23V to 37V
- ◆ V_{OUT} accuracy is up to $\pm 2\%$ under specified input voltage the output load conditions
- ◆ Input voltage range up to 40V
- ◆ Requires only 4 external components with High efficiency
- ◆ TTL shutdown capability, low power standby mode
- ◆ Built-in thermal shutdown, current limit protection
- ◆ Uses standard inductors
- ◆ 52 kHz fixed frequency internal oscillator

Application

Pre-regulator for linear regulators

On-card/board switching regulators

High-efficiency step-down buck regulator

Positive to negative converter (buck-boost)

Typical Application Circuits

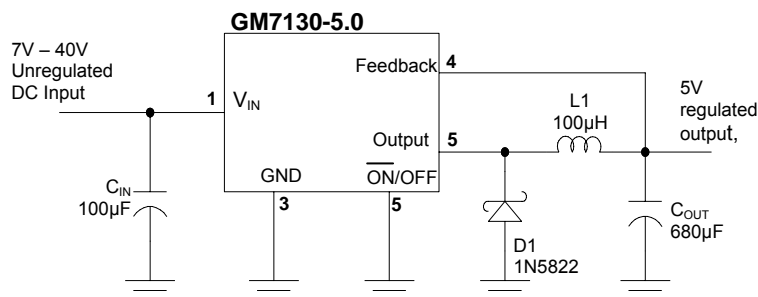

Marking Information and Pin Configurations (Top View)

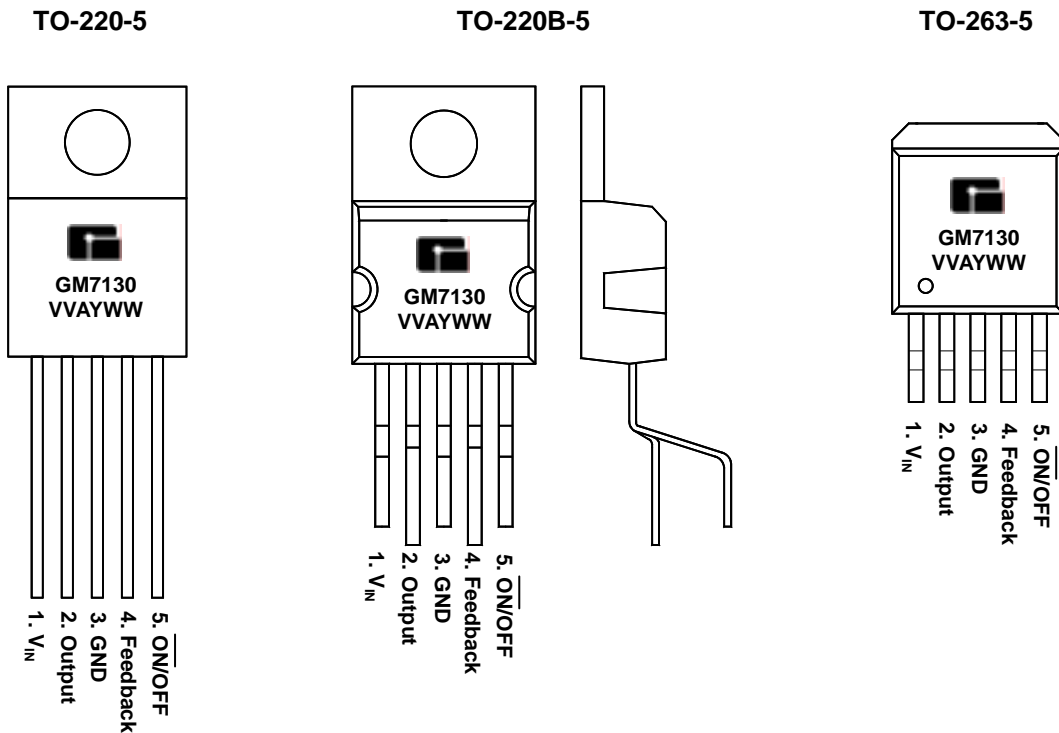

VV: Voltage suffix (15 = 1.5V, 50 = 5.0V...A = Adj)
 A: Assembly / Test site code
 Y: Year
 WW: Week

Ordering Information

Ordering Number	Output Voltage	Package	Shipping
GM7130-ATA5T	Adj	TO-263-5	50 Units / Tube
GM7130-ATA5R		TO-263-5	800 Units / Reel
GM7130-ATB5T		TO-220-5	50 Units / Tube
GM7130-ATB5BT		TO-220-5B	50 Units / Tube
GM7130-3.3TA5T	3.3	TO-263-5	50 Units / Tube
GM7130-3.3A5R		TO-263-5	800 Units / Reel
GM7130-3.3B5T		TO-220-5	50 Units / Tube
GM7130-3.3B5BT		TO-220-5B	50 Units / Tube
GM7130-5.0TA5T	5.0	TO-263-5	50 Units / Tube
GM7130-5.0A5R		TO-263-5	800 Units / Reel
GM7130-5.0B5T		TO-220-5	50 Units / Tube
GM7130-12B5BT		TO-220-5B	50 Units / Tube
GM7130-12TA5T	12	TO-263-5	50 Units / Tube
GM7130-12A5R		TO-263-5	800 Units / Reel
GM7130-12B5T		TO-220-5	50 Units / Tube
GM7130-12B5BT		TO-220-5B	50 Units / Tube

Absolute Maximum Ratings (Note 1)

Rating		Value	Unit	
Maximum Supply Voltage		45	V	
$\overline{\text{ON/OFF}}$ Pin Input Voltage		$-0.3 + V_{\text{IN}} + 0.3$	V	
Feedback Pin Voltage		$-0.3 + V_{\text{IN}} + 0.3$	V	
Output Voltage to Ground (Steady State)		-1.0	V	
Power Dissipation		Internally Limited	-	
Thermal Resistance*	Junction to Ambient, θ_{JA}	TO-220-5	65	°C/W
		TO-263-5	45	
	Junction to Case, θ_{JC}	TO-220-5	2	
		TO-263-5	2	
Storage Temperature Range		- 65 to 150	°C	
Maximum Junction Temperature		+ 150	°C	
Operating Temperature Range		- 40 to 125	°C	
Minimum ESD Rating (Note 2)		2	kV	
Lead Temperature (Soldering, 10 sec)		+ 260	°C	

* θ_{JA} is measured with minimum copper area for TO-220-5 package, and copper area (must connected to ground) of around 0.5 in² for TO-263-5 package.

Block Diagram

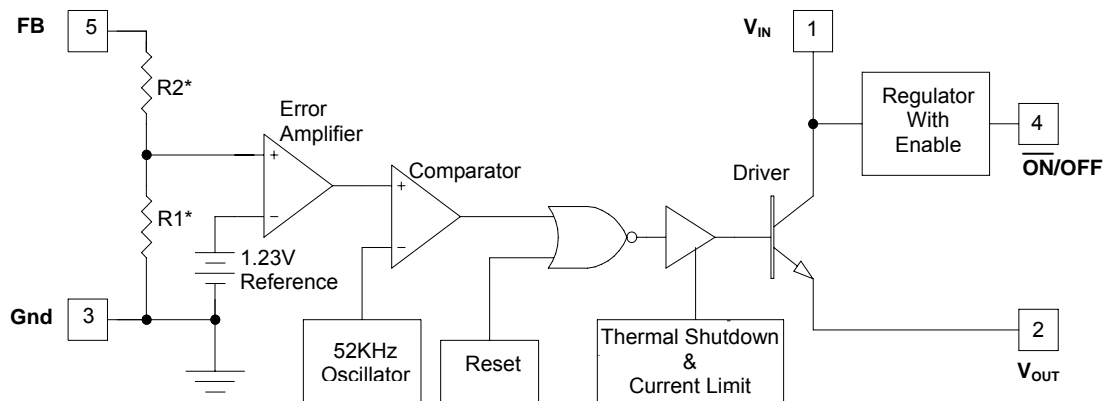

$V_{\text{OUT}} = 3.3\text{V}$, $R_1 = 2.49\text{K}$, $R_2 = 4.18\text{K}$
 $V_{\text{OUT}} = 5.0\text{V}$, $R_1 = 2.49\text{K}$, $R_2 = 7.57\text{K}$
 $V_{\text{OUT}} = \text{ADJ}$, $R_1 = \text{OPEN}$, $R_2 = 0\Omega$

Electrical Characteristics: GM7130-ADJ

(Specifications with standard type face are for $T_j = 25^\circ\text{C}$, and those with bold face type apply over full Operating Temperature range)

Parameter	Condition	Symbol	Min	Typ	Max	Unit
Feedback Voltage	$V_{IN} = 12\text{V}, I_{LOAD} = 0.5\text{A}, V_{OUT} = 5\text{V}$	V_{OUT}	1.217	1.230	1.243	V
	$8.0\text{V} \leq V_{IN} \leq 40\text{V}, 0.5\text{A} \leq I_{LOAD} \leq 3\text{A}, V_{OUT} = 5\text{V}$		1.193		1.267	
			1.180		1.280	
Efficiency	$V_{IN} = 12\text{V}, I_{LOAD} = 3.0\text{A}, V_{OUT} = 5\text{V}$	η		77		%

Electrical Characteristics: GM7130-3.3

(Specifications with standard type face are for $T = 25^\circ\text{C}$, and those with bold face type apply over full Operating Temperature range)

Parameter	Condition	Symbol	Min	Typ	Max	Unit
Output Voltage	$V_{IN} = 12\text{V}, I_{LOAD} = 0.5\text{A}$	V_{OUT}	3.234	3.300	3.366	V
	$6\text{V} \leq V_{IN} \leq 40\text{V}, 0.5\text{A} \leq I_{LOAD} \leq 3\text{A}$		3.168		3.432	
			3.135		3.465	
Efficiency	$V_{IN} = 12\text{V}, I_{LOAD} = 3.0\text{A}$	η		75		%

Electrical Characteristics: GM7130-5.0

(Specifications with standard type face are for $T = 25^\circ\text{C}$, and those with bold face type apply over full Operating Temperature range)

Parameter	Condition	Symbol	Min	Typ	Max	Unit
Output Voltage	$V_{IN} = 12\text{V}, I_{LOAD} = 0.5\text{A}$	V_{OUT}	4.900	5.000	5.100	V
	$8\text{V} \leq V_{IN} \leq 40\text{V}, 0.5\text{A} \leq I_{LOAD} \leq 3\text{A}$		4.800		5.200	
			4.750		5.250	
Efficiency	$V_{IN} = 12\text{V}, I_{LOAD} = 3.0\text{A}$	η		77		%

Electrical Characteristics: GM7130-12

(Specifications with standard type face are for $T = 25^\circ\text{C}$, and those with bold face type apply over full Operating Temperature range)

Parameter	Condition	Symbol	Min	Typ	Max	Unit
Output Voltage	$V_{IN} = 25\text{V}, I_{LOAD} = 0.5\text{A}$	V_{OUT}	11.76	12.00	12.24	V
	$15\text{V} \leq V_{IN} \leq 40\text{V}, 0.5\text{A} \leq I_{LOAD} \leq 3\text{A}$		11.52		12.48	
			11.40		12.60	
Efficiency	$V_{IN} = 15\text{V}, I_{LOAD} = 3.0\text{A}$	η		88		%

Electrical Characteristics: All Output Voltage Versions

(Specifications with standard type face are for $T_J = 25^\circ\text{C}$, and those with bold face type apply over full Operating Temperature range. Unless otherwise specified, $V_{IN} = 12\text{V}$ for 3.3V, 5.0V and Adj version, $V_{IN} = 25\text{V}$ for 12V version, $I_{LOAD} = 500\text{mA}$)

Parameter	Condition	Symbol	Min	Typ	Max	Unit
Feedback Bias Current	$V_{OUT} = 5\text{V}$ (Adjustable Version Only)	I_b	-	50	100	nA
					500	
Oscillator Frequency	(Note 3)	f_o	47	52	58	kHz
			42		63	
Saturation Voltage	$I_{OUT} = 3\text{A}$ (Notes 4, 5)	V_{SAT}	-	1.4	1.8	V
					2.0	
Max Duty Cycle (ON)	(Note 5)	DC	93	98	-	%
Current Limit	Peak Current (Notes 4, 5)	I_{CL}	4.2	5.8	6.9	A
			3.5		7.5	
Output Leakage Current	Output = 0V (Notes 4, 6)	I_L	-	7.5	2	mA
	Output = -1V (Notes 4, 6)				30	
Quiescent Current	(Note 6)	I_Q	-	5	10	mA
Standby Quiescent Current	$\overline{\text{ON/OFF}} = 5\text{V}$ (OFF)	I_{STBY}	-	50	200	μA
$\overline{\text{ON/OFF}}$ Pin Logic Input Level	Low (ON)	V_{IH}	-	1.2	1.0	V
	High (OFF)	V_{IL}	2.2	1.4	-	
			2.4			
$\overline{\text{ON/OFF}}$ Pin Input Current	$V_{LOGIC} = 2.5\text{V}$ (OFF)	I_H		12	30	μA
	$V_{LOGIC} = 0.5\text{V}$ (ON)	I_L		0	10	

Note 1: Stresses greater than those listed under Maximum Ratings may cause permanent damage to the device. This is a stress rating only and functional operation of the device at these or any other conditions above those indicated in the operation is not implied. Exposure to absolute maximum rating conditions for extended periods may affect reliability.

Note 2: The human body model is a 100pF capacitor discharge through a 1.5K Ω resistor into each pin.

Note 3: External components such as the catch diode, inductor, input and output capacitors, and voltage programming resistors can affect switching regulator system performance. Where the GM2576 is used as shown in Figure 1&2 test circuits.

Note 4: No diode, inductor or capacitor connected to output pin.

Note 5: Feedback pin removed from output and connected to 0V to force the output transistor switch ON.

Note 6: Feedback pin removed from output and connected to 12V for the 3.V, 5V and Adj version, to force the output transistor switch OFF.

Test Circuit and Layout Guidelines

Careful layout is important with any switching regulators. Rapidly switching currents associated with wiring inductance generate voltage transients which can cause problems. To minimize inductance and ground loops, the lengths of the leads indicated by heavy lines in Figure 1&2 below should be kept as short as possible. Single point grounding (as indicated or ground plane construction should be used for best results. When using the Adjustable version, place the programming resistors as close as possible to GM2576, to keep the sensitive feedback wiring short.

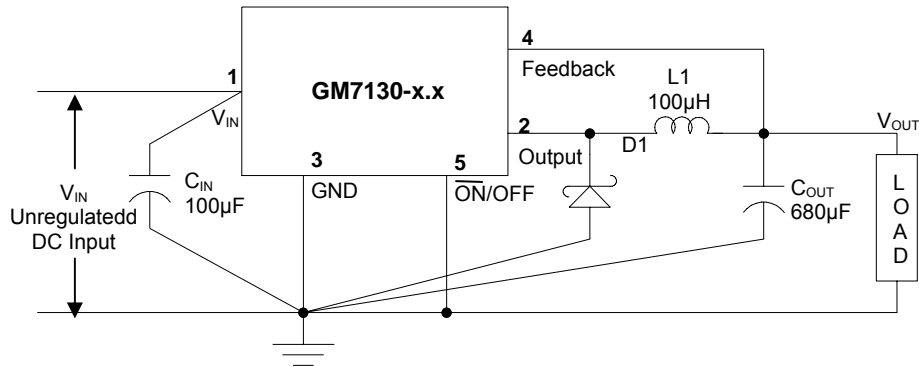

Figure 1 Fixed Output Voltage Versions

$C_{IN} = 100\mu\text{F}$, Aluminum Electrolytic
 $C_{OUT} = 680\mu\text{F}$, 25V, Aluminum Electrolytic
 D1 = Schottky
 L1 = 100µH

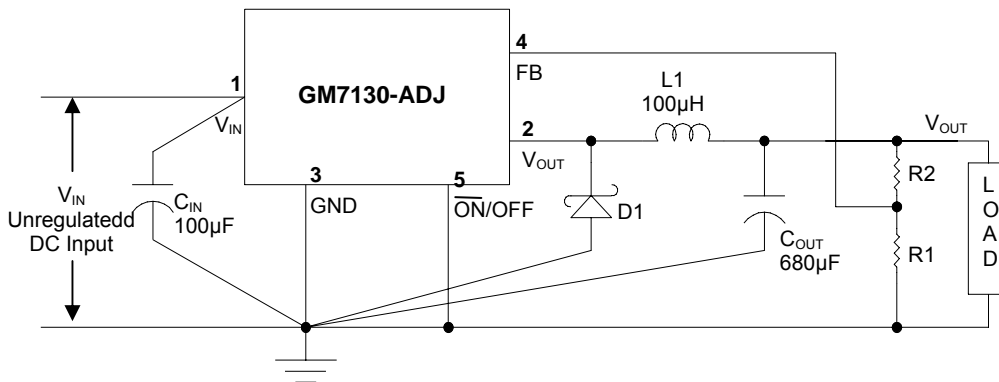

Figure 2 Adjustable Output Voltage Versions

$C_{IN} = 100\mu\text{F}$, Aluminum Electrolytic
 $C_{OUT} = 680\mu\text{F}$, 25V, Aluminum Electrolytic
 D1 = Schottky
 L1 = 100µH

$$V_{OUT} = V_{REF} (1 + R2/R1)$$

where $V_{REF} = 1.23\text{V}$ and R1 is between 1K to 5K

Package Outline Dimensions – TO-263-5

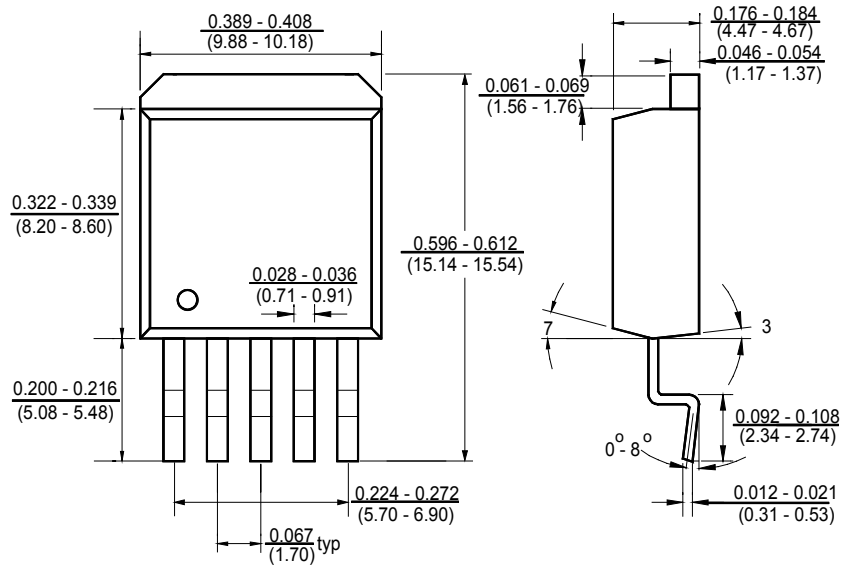

Package Outline Dimensions – TO-220-5

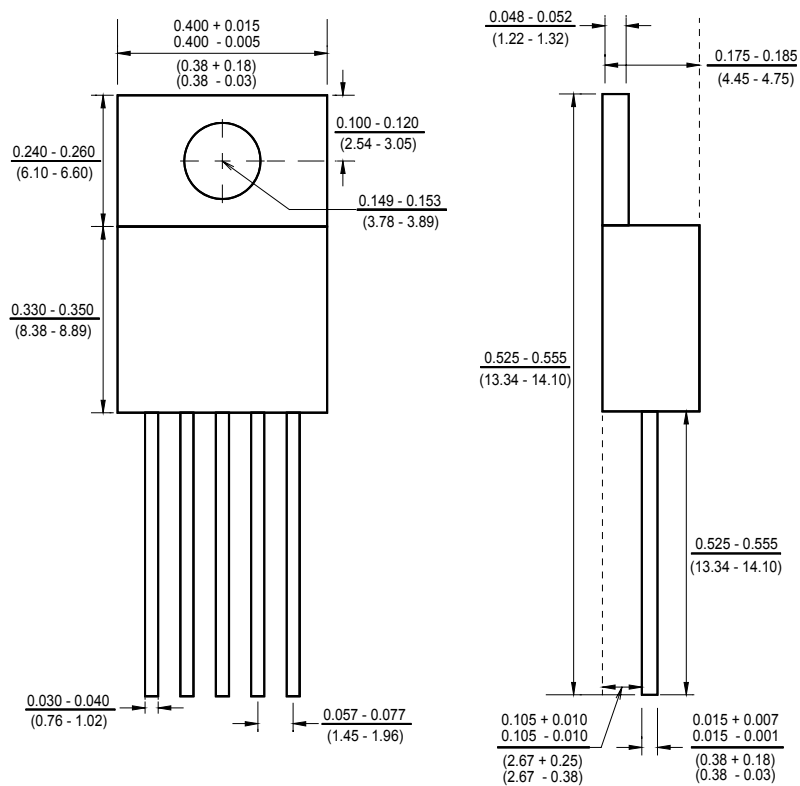

Ordering Number

<u>GM</u>	<u>7130</u>	<u>A</u>	<u>TA5</u>	<u>R</u>
APM Gamma Micro	Circuit Type	Output Voltage A: Adj 3.3 = 3.3V 5.0 = 5.0V 12 = 12.0V	Package Type TA5: TO263-5 TB5: TO-220-5 TB5B: TO-220B-5	Shipping Type R: Taping & Reel T: Tube