

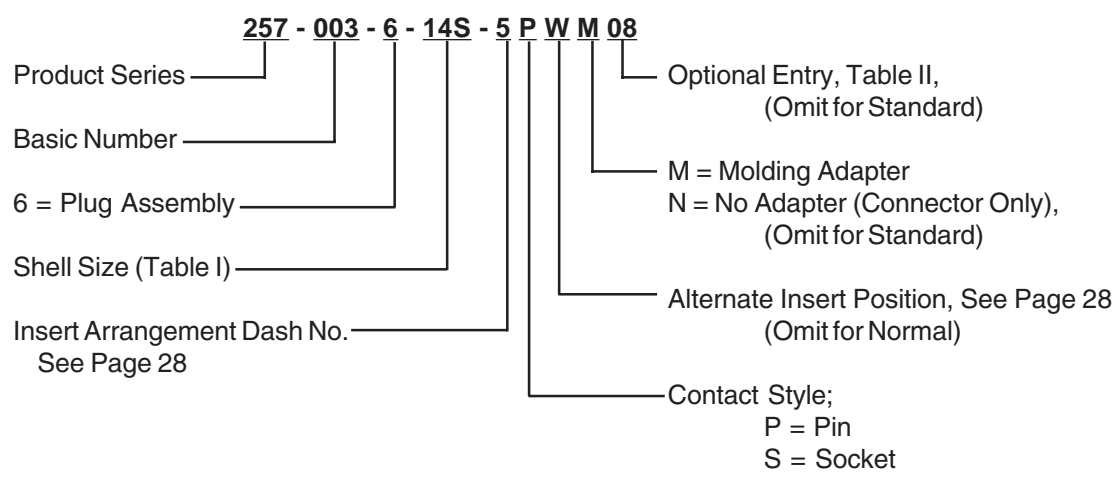

257-003
Connector Plug Assembly
Stainless Steel Harsh Environment

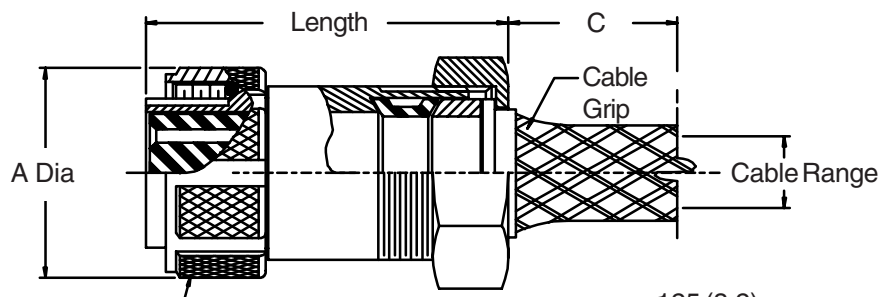

STYLE I



Knurl Style Mfr Option

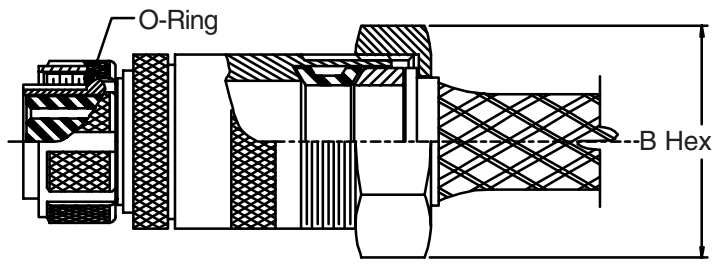

STYLE II

.125 (3.2) Sand Blast

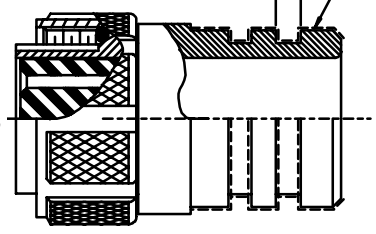

STYLE M
MOLDING ADAPTER
OPTION

257-003
Connector Plug Assembly
Stainless Steel Harsh Environment



TABLE I

Shell Size	A Max	B Flats	Standard Cable Range		Config. Style	Max Cable Entry (Table II)	Length Max
			Min	Max			
10SL	1.031 (26.2)	1.000 (25.4)	.210 (5.3)	.312 (7.9)	I	04	3.000 (76.2)
12	1.125 (28.6)	1.380 (35.1)	.500 (12.7)	.625 (15.9)	II	08	3.000 (76.2)
14S	1.219 (31.0)	1.000 (25.4)	.210 (5.3)	.312 (7.9)	I	10	3.000 (76.2)
18	1.406 (35.7)	1.220 (31.0)	.310 (7.9)	.438 (11.1)	I	12	3.000 (76.2)
20	1.531 (38.9)	1.500 (38.1)	.530 (13.5)	.750 (19.1)	I	14	3.500 (88.9)
24	1.781 (45.2)	1.500 (38.1)	.530 (13.5)	.750 (19.1)	I	16	3.500 (88.9)
28	2.031 (51.6)	1.500 (38.1)	.530 (13.5)	.750 (19.1)	I	16	3.500 (88.9)

TABLE II

Dash No.	C Ref	Cable Range	
		Min	Max
03	5.120 (130.0)	.180 (4.6)	.210 (5.3)
04	5.750 (146.1)	.210 (5.3)	.312 (7.9)
06	7.000 (177.8)	.310 (7.9)	.438 (11.1)
08	7.120 (180.8)	.438 (11.1)	.500 (12.7)
10	7.370 (184.3)	.500 (12.7)	.625 (15.9)
12	9.000 (228.6)	.530 (13.5)	.750 (19.1)
14	8.000 (203.2)	.750 (19.1)	.875 (22.2)
16	9.000 (228.6)	.875 (22.2)	1.000 (25.4)

1. Metric dimensions (mm) are indicated in parentheses.
2. Electrical safety limits must be established by the user. Peak voltages, switching surges, etc., should be used to determine the safety of the application.