

## 8-Bit Constant Current LED Driver

### DESCRIPTION

SD16730 is a special constant current driver for LED display application. The value of constant current can be determined with external resistor. It bases on BICMOS technology and includes an 8-bit shift register. Latch and constant current driver. At the output stage, there are eight regulated current sources which provide 2-80mA constant current for driving LEDs by Bipolar Junction Transistor.

### FEATURES

- \* Output current adjustable through an external resistor
- \* Serial data in/out
- \* 8 constant-current output channels
- \* Output current: 2-80mA
- \* 20MHz clock frequency
- \* Current accuracy (All output ON)

Current accuracy		Output current
Between Bits	Between ICs	
<±3%	<±6%	10 to 60mA

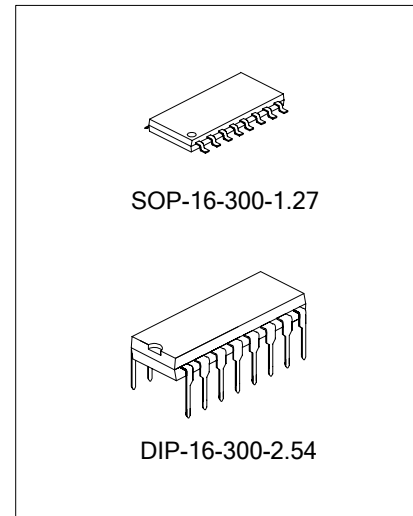

### APPLICATIONS

- \* LED guardrail diode

### ORDERING INFORMATION

Device	Package	Seal
SD16730	DIP-16-300-2.54	SD16730
SD16730S	SOP-16-300-1.27	SD16730S

**BLOCK DIAGRAM**

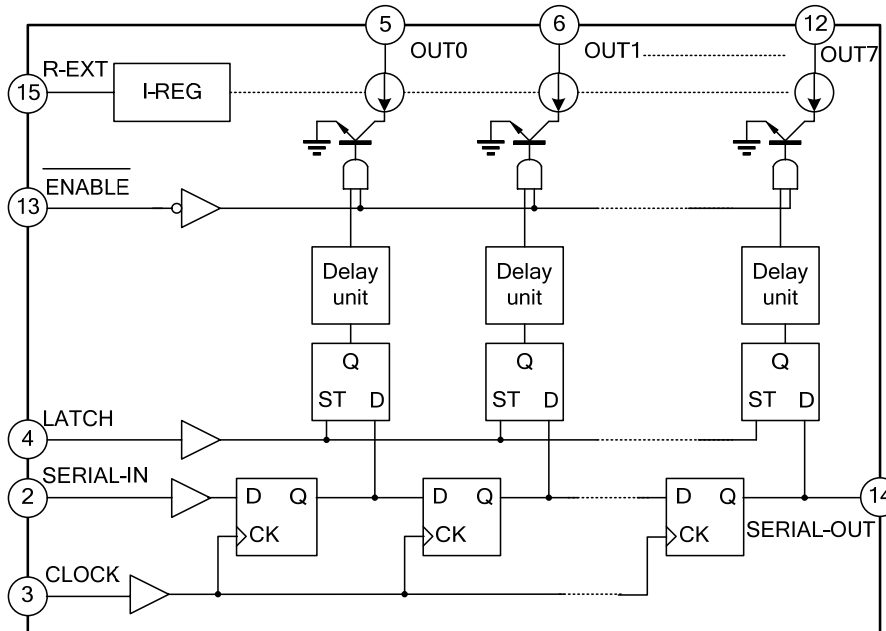

**ABSOLUTE MAXIMUM RATING (Tamb=25°C)**

Characteristics	Symbol	Value	Unit
Supply Voltage	VDD	6	V
Input Voltage	VIN	-0.2~VDD-0.2	V
Output Current	IOUT	90	mA/ch
Output Voltage	VOUT	-0.2~ 17	V
Power Dissipation	PD1	1.25	W
Storage Temperature	Tstg	-55~+150	°C
Operating Temperature	Topr	-40 ~ 85	°C

**RECOMMENDED OPERATE CONDITION**

Characteristics	Symbol	Test conditions	Min.	Typ.	Max.	Unit
Supply Voltage	VDD	-	3.0	-	5.5	V
Output Voltage	VOUT	-	-	0.7	4.0	V
Output Current	IOUT	-	2	-	80	mA/ch
	IOH	SERIAL-OUT	-	-	1	mA
	IOL	SERIAL-OUT	-	-	-1	mA
Input Voltage	VIH	-	0.74VDD	-	VDD+ 0.15	V
Input Voltage	VIL	-	-0.15	-	0.26VDD	V
Clock Frequency	Fclk	Cascade connected	-	-	20	MHz
Setup Time For LATCH	TSU(L)	-	50	-	-	nS

Characteristics	Symbol	Test conditions	Min.	Typ.	Max.	Unit
Hold Time For LATCH	Th(L)		50	-	-	nS
CLOCK Pulse Width	tCLK		25	-	-	nS
ENABLE Pulse Width	tENA	Upper IOUT = 20 mA	175	-	-	nS
		Lower IOUT = 20 mA	130	-	-	nS
Setup Time For CLOCK	Tsu(C)	-	10	-	-	nS
Hold Time For CLOCK	Th(C)	-	10	-	-	nS

**ELECTRICAL CHARACTERISTICS** (Tamb=25°C, VDD=3.0V-5.5V unless otherwise specified)

Characteristics	Symbol	Test conditions	Min.	Typ.	Max.	Unit
Supply Voltage	VDD	-	3.0	-	5.5	V
Output Current	IOUT1	VDD=3.3V VOUT=0.4V REXT=490Ω	31.96	36.20	40.54	mA
	IOUT2	VDD=5.0V VOUT=0.4V REXT=490Ω	31.59	35.90	40.02	mA
	IOUT3	VDD=3.3V VOUT=0.7V REXT=250Ω	63.63	72.30	80.97	mA
	IOUT4	VDD=5.0V VOUT=0.7V REXT=250Ω	62.75	71.30	79.95	mA
Output Leakage Current	Iok	VOUT=15.0V	-	-	1	uA
Output Current (Bit to Bit)	ΔIout1	VOUT>0.4V REXT=490Ω	-	±1	±3	%
	ΔIout2	VOUT>0.4V REXT=250Ω	-	±1	±3	%
Output Voltage (SOUT)	VOH	IOH=-1.0 mA, VDD=3.3 V	3	-	-	V
		IOH=-1.0 mA, VDD=5.0 V	4.7	-	-	V
	VOL	IOL=1.0 mA, VDD=3.3 V	-	-	0.3	V
		IOL=1.0 mA, VDD=5.0 V	-	-	0.3	V
Output Current Regulation	%/VDD	VDD:3.0V-5.0V	-	-1	-5	%
Pull-down Resistor	RIN(down)	-	115	230	460	kΩ
Pull-up Resistor	RIN(up)	-	115	230	460	kΩ
Supply Current OFF	IOFF	Vout=15.0V, OPEN	-	0.1	0.5	mA
		Vout=15.0V,REXT=490Ω	1	3.5	5	mA
		Vout=15.0V,REXT=250Ω	4	6	9	mA
Supply Current ON	ION	VOUT=0.7V,REXT=490Ω	-	5.5	15	mA
		VOUT=0.7V,REXT=250Ω	-	10.5	25	mA
	ION	VOUT=0.7V,Tamb=-40°C, REXT=490Ω	-	-	20	mA
		VOUT=0.7V,Tamb=-40°C, REXT=250Ω	-	-	40	mA
Propagation Delay Time ("L" to "H")	TpLH1	CLK - OUTn, LATCH="H", ENABLE="L"	-	140	300	nS
	TpLH2	LATCH - OUTn, ENABLE="L"	-	140	300	nS
	TpLH3	ENABLE - OUTn, LATCH="H"	-	140	300	nS
	TpLH4	CLK - SERIAL OUT	3	6	-	nS

Characteristics	Symbol	Test conditions	Min.	Typ.	Max.	Unit
Propagation Delay Time ("H" to "L")	T <sub>pHL1</sub>	CLK – OUT <sub>n</sub> , LATCH = "H", ENABLE = "L"	-	170	340	nS
	T <sub>pHL2</sub>	LATCH – OUT <sub>n</sub> , ENABLE = "L"	-	170	340	nS
	T <sub>pHL3</sub>	ENABLE – OUT <sub>n</sub> , LATCH = "H"	-	170	340	nS
	T <sub>pHL4</sub>	CLK – SERIAL OUT	4	7	-	nS
Output Rise Time	t <sub>or</sub>	-	40	85	150	nS
Output Fall Time	t <sub>of</sub>	-	40	70	150	nS
Maximum CLOCK Rise Time	t <sub>r</sub>	-	-	-	5	uS
Maximum CLOCK Fall Time	t <sub>f</sub>	-	-	-	5	uS

## PIN CONFIGURATION

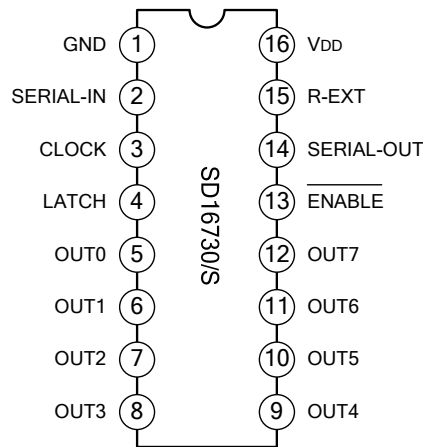

## PIN DESCRIPTIONS

Pin No.	Pin Name	I/O	Description
1	GND	--	Ground terminal
2	SERIAL-IN	I	Input terminal of a data shift register
3	CLOCK	I	Input terminal of a clock shift register
4	LATCH	I	Input terminal of a data strobe
5 ~ 12	OUT <sub>0</sub> ~ OUT <sub>7</sub>	O	Output terminals
13	ENABLE	I	Input terminal of output enable (low active)
14	SERIAL-OUT	O	output terminal of a data shift register
15	R-EXT	I	Input terminal of an external resistor
16	VDD	--	Supply voltage terminal

## FUNCTION DESCRIPTION

In LED display application, SD16730 can maintain the current nearly no variations among different channels or chips. The maximum current variation range is  $\pm 3\%$  between channels and  $\pm 6\%$  between chips.

This device has only one ground pin shared by signal, output sink current, and power ground. It is advisable to pattern the ground layout with minimized inductance so that the switching noise induced by the input signals and the output sink current would not cause chip malfunction. To prevent drivers' outputs from damaging by

overshoot stresses, it is also advisable not to turn off the drivers and scan transistors simultaneously. In order to obtain an ideal constant current output, a suitable output voltage is necessary. Users can get related information about the minimum output voltage from the character table. Even under the same output current condition, the minimum output voltage required for each part is different. The resistor should be placed as close as possible to the R-EXT terminal to avoid the noise influence.

### TIMING DIAGRAM

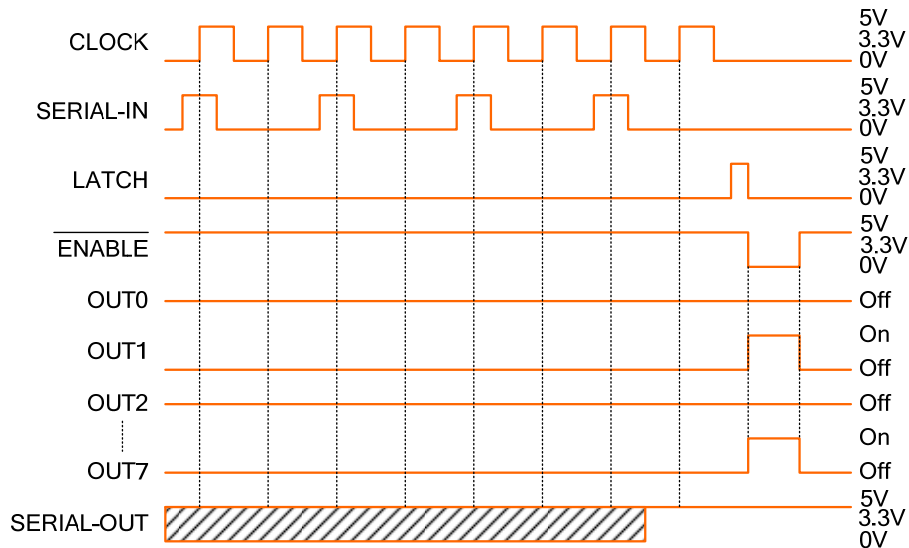

Note: The latches circuit holds data when LATCH terminal goes low voltage.

When LATCH terminal is a high voltage, latch circuit does not hold data, and it passes from the input to the output.

When  $\overline{\text{ENABLE}}$  terminal is a low voltage, output terminals respond to the data, and on and off does.

When  $\overline{\text{ENABLE}}$  terminal is a high voltage, it closes with the output terminal regardless of the data.

**TIMING WAVEFORM**

**1. Clock, serial-in, serial-out**

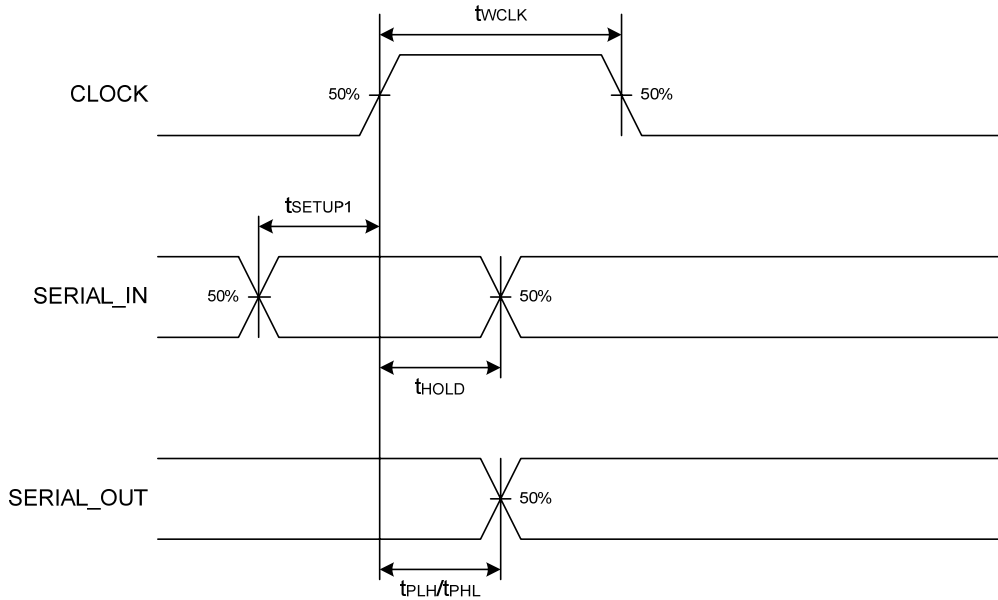

**2. Clock, serial-in, LATCH, ENABLE , OUTn**

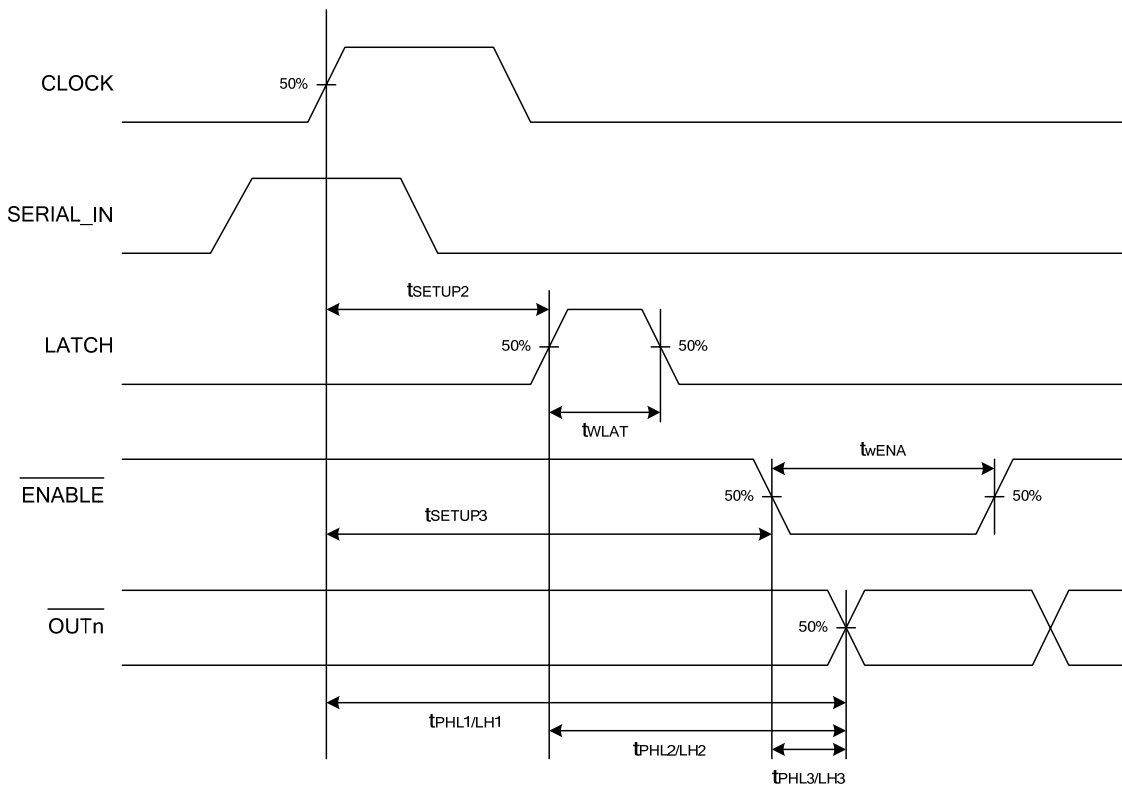

3.  $\overline{\text{OUTn}}$

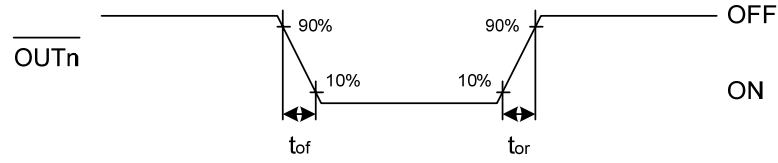

ELECTRICAL CHARACTERISTICS CURVE

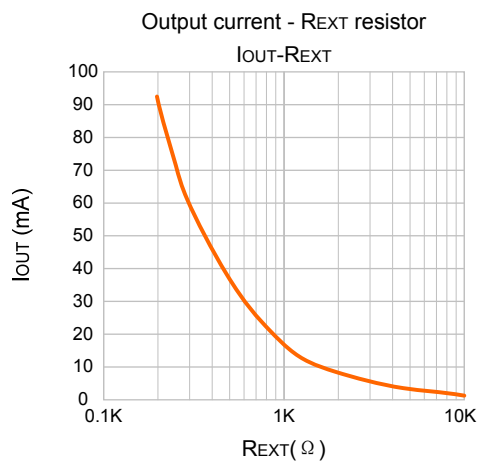

The calculation formula is as follows:

$$I_{OUT} = (V_{R-EXT} / R_{EXT}) \times 16; V_{R-EXT} = 1.185V$$

Where, V<sub>R-EXT</sub> is voltage on R-EXT port, R<sub>EXT</sub> is the external resistance of R-EXT Port.

TEST CIRCUIT

DC CHARACTERISTIC

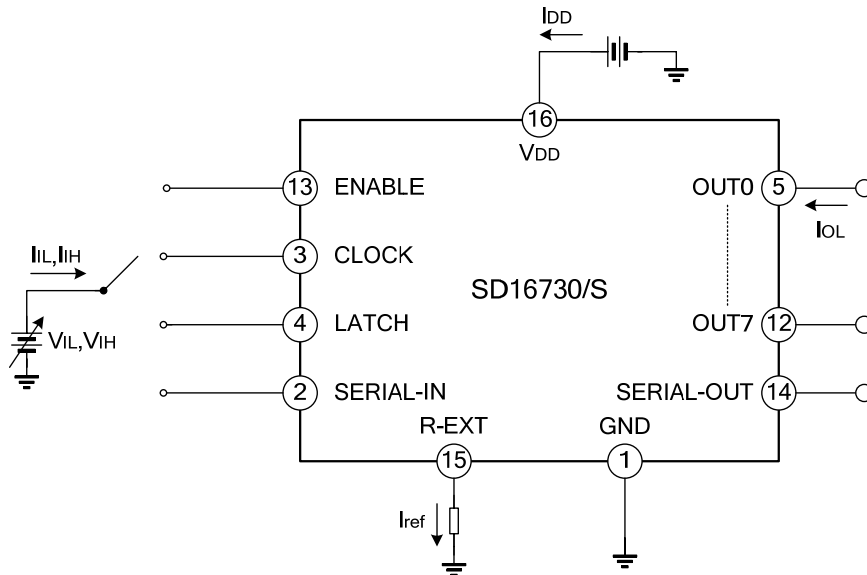

AC CHARACTERISTIC

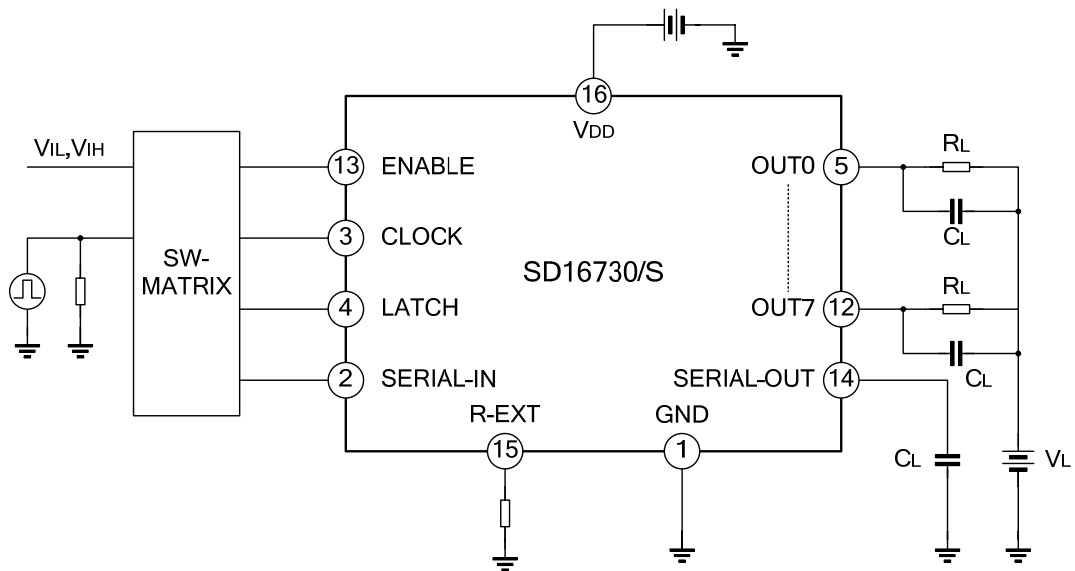



TYPICAL APPLICATION CIRCUIT

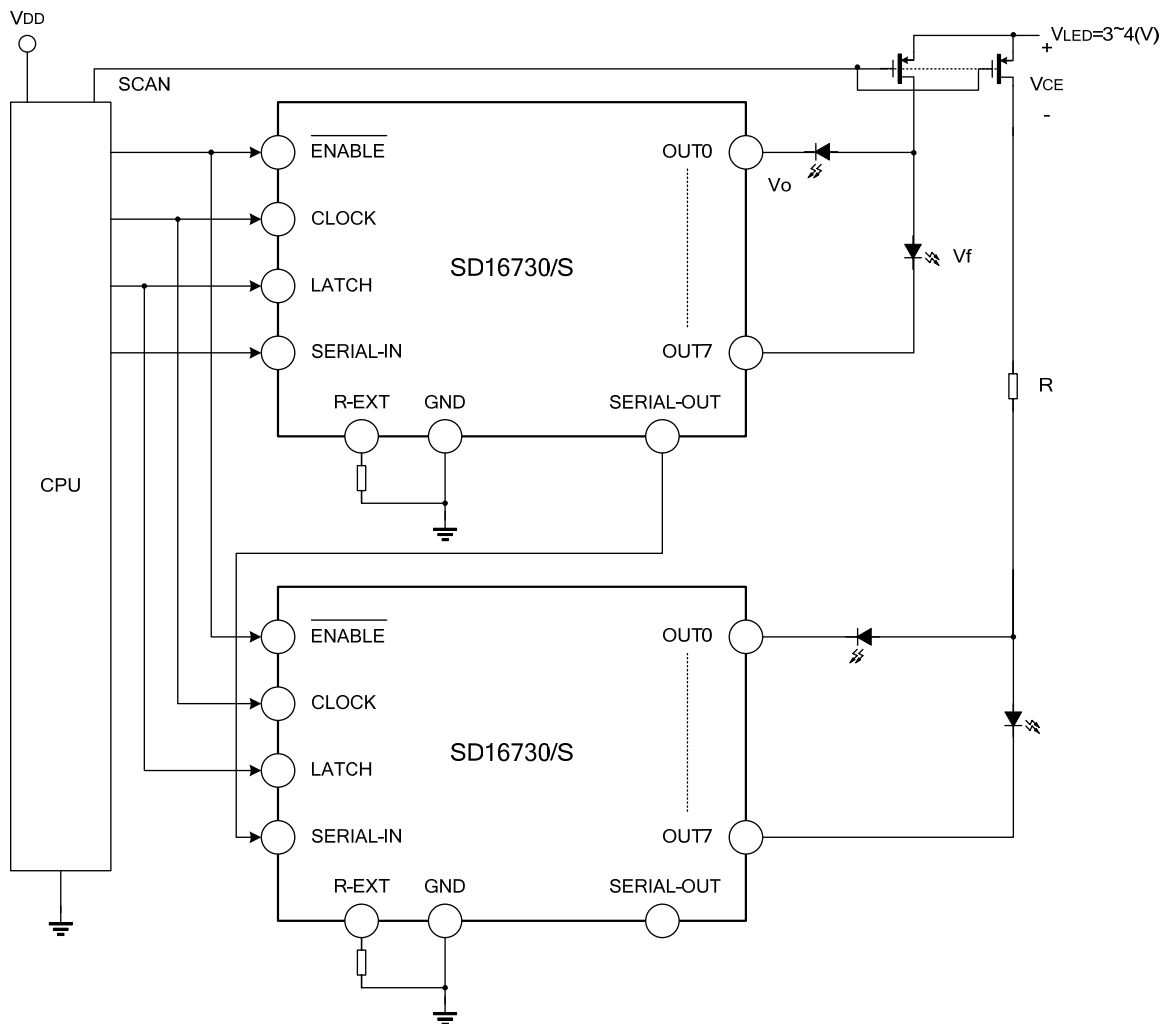

Note: The circuit and parameters are reference only, please set the parameters of the real application circuit based on the real test.

PACKAGE OUTLINE

DIP-16-300-2.54

UNIT: mm

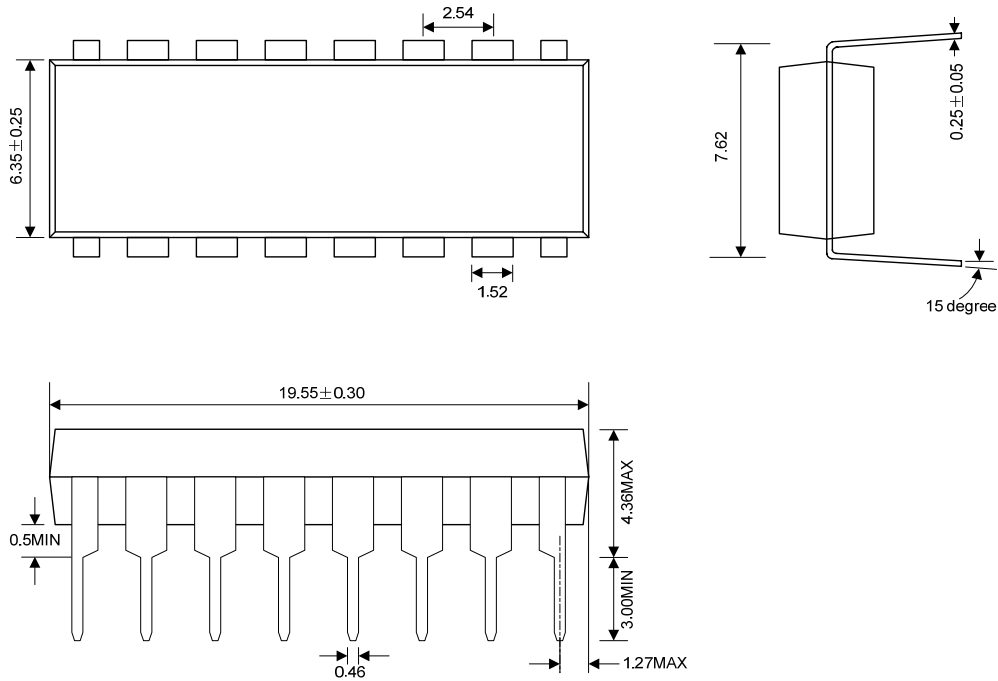

SOP-16-300-1.27

UNIT: mm

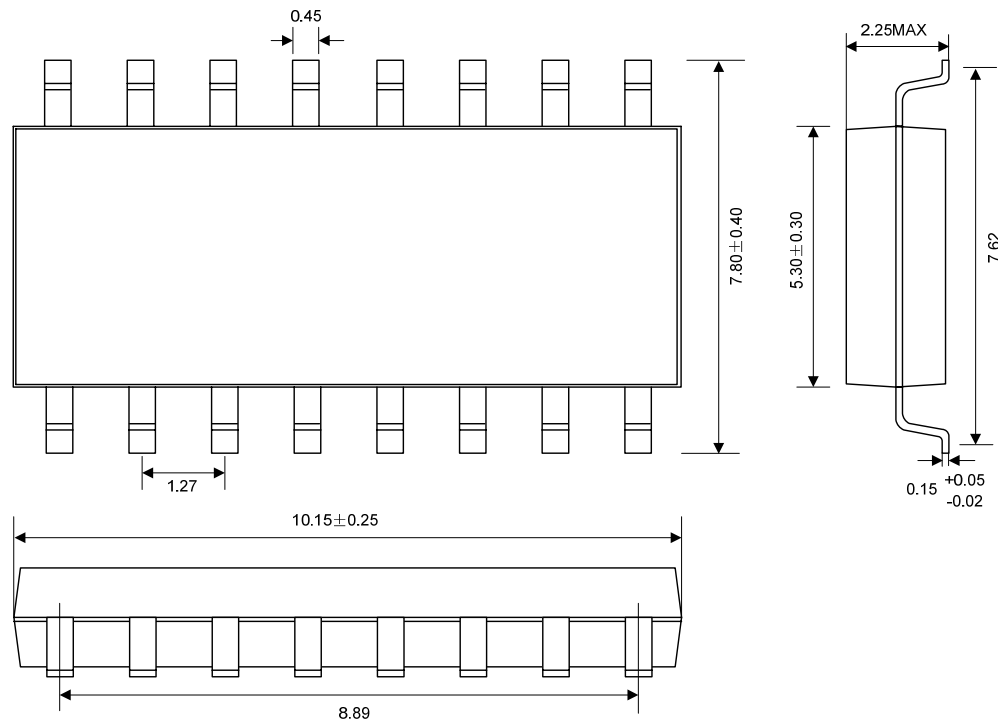



**MOS DEVICES OPERATE NOTES:**

Electrostatic charges may exist in many things. Please take following preventive measures to prevent effectively the MOS electric circuit as a result of the damage which is caused by discharge:

- The operator must put on wrist strap which should be earthed to against electrostatic.
- Equipment cases should be earthed.
- All tools used during assembly, including soldering tools and solder baths, must be earthed.
- MOS devices should be packed in antistatic/conductive containers for transportation.

Note: Silan reserves the right to make changes without notice in this specification for the improvement of the design and performance.  
Silan will supply the best possible product for customers.



Attachment

Revision History

Data	REV	Description	Page
2008.06.23	1.0	Original	
2008.11.16	1.1	Modify the "RECOMMENDED OPERATE CONDITION" and "ELECTRICAL CHARACTERISTICS"	