

Voltage Detector ICs

Bipolar Voltage Detector ICs

BD47□□G series

No.10006ECT05

● Description

The BD47□□G Series is a reset IC that was developed to prevent system errors at transient state when the power of CPU or logic circuit switches ON/OFF or momentary shut down. These ICs consist of three terminals (power supply, GND and reset output) to detect power supply voltages and outputs reset signals of various systems. These ICs are ultra-compact and are realized low current consumption, making them ideal for portable products.

● Features

- 1) Detection voltage range: 0.1-volt step line-up 1.9~4.6V (Typ.)
- 2) High accuracy voltage detection: $\pm 1\%$
- 3) Low current consumption
- 4) Open collector "L" reset output
- 5) Compact SSOP5 package

● Applications

All electronic devices that use microcontrollers and logic circuits

● Selection Guide

Part Number : BD47 □ □ G

↑
①

No.	Specifications	Description
①	Detection Voltage	Example: Voltage range over 1.9V~4.6V in 0.1V increments. 2.9V is marked as "29"

● Lineup

Marking	Detection Voltage	Part Number	Marking	Detection Voltage	Part Number	Marking	Detection Voltage	Part Number
B2	4.6V	BD4746	BR	3.6V	BD4736	BH	2.6V	BD4726
B1	4.5V	BD4745	BQ	3.5V	BD4735	BG	2.5V	BD4725
BZ	4.4V	BD4744	BP	3.4V	BD4734	BF	2.4V	BD4724
BY	4.3V	BD4743	B4	3.3V	BD4733	BE	2.3V	BD4723
BX	4.2V	BD4742	BN	3.2V	BD4732	BD	2.2V	BD4722
BW	4.1V	BD4741	BM	3.1V	BD4731	BC	2.1V	BD4721
BV	4.0V	BD4740	BL	3.0V	BD4730	BB	2.0V	BD4720
BU	3.9V	BD4739	BK	2.9V	BD4729	BA	1.9V	BD4719
BT	3.8V	BD4738	BJ	2.8V	BD4728			
BS	3.7V	BD4737	B3	2.7V	BD4727			

● Absolute maximum ratings (Ta=25°C)

Parameter	Symbol	Limits	Unit
Power Supply Voltage	Vcc-GND	-0.3 ~ +10	V
Output Voltage	Vout	-0.3 ~ +10	V
Power Dissipation	Pd	540	mW
Operating Temperature	Topr	-40 ~ +75	°C
Ambient Storage Temperature	Tstg	-55 ~ +125	°C

*1 When a ROHM standard circuit board (70mm×70mm×1.6mm glass epoxy board) is mounted.

*2 When used at temperatures higher than Ta=25°C, the power is reduced by 5.4mW/°C

● Electrical characteristics (Unless Otherwise Specified Ta=25°C)

Parameter	Symbol	Condition	Limit			Unit
			Min.	Typ.	Max.	
Detection Voltage	Vs	Vcc=H→L RL=4.7kΩ	Vs (T) ×0.99	Vs (T)	Vs (T) ×1.01	V
Temperature Coefficient Of Detection Voltage	Vs/ΔT	RL=4.7kΩ Ta=-20~+75°C Designed Guarantee	-	±0.01	-	%/°C
Detection Hysteresis Voltage	ΔVs	RL=4.7kΩ, Vcc=L→H→L	30	50	100	mV
Transfer Delay Time "H"	tPLH	CL=100pF, RL=4.7kΩ *1	-	20	50	μs
Transfer Delay Time "L"	tPHL	CL=100pF, RL=4.7kΩ *2	-	60	120	μs
Reset Output Voltage "L"	VOL	Vcc=Vs(min.)-0.05V, RL=4.7kΩ	-	0.1	0.4	V
Circuit Current ON	Icc1	Vcc=Vs(min.)-0.05V, RL=∞	-	1.5	3.0	μA
Circuit Current OFF	Icc2	Vcc=Vs(typ.)/0.85V, RL=∞	-	1.6	3.2	μA
Threshold Operating Voltage	VOPL	RL=4.7kΩ, VOL≥0.4V	-	0.65	0.85	V
Output Leak Current	IL	Vcc=VOUT=10V	-	-	0.1	μA
Reset Output Current "L"	IOL	Vo=0.4V, Vcc=Vs(min.)-0.05V	3.0	15.0	-	mA

Vs(T):Standard Detection Voltage (1.9V to 4.6V, 0.1V step)
 RL: Pull-up resistor to be connected between VOUT and power supply.
 CL: Capacitor to be connected between VOUT and GND.
 *1 tPLH: Vcc=(Vs(typ.)-0.4V)→(Vs(typ.)+0.4V)
 *2 tPHL: Vcc=(Vs(typ.)+0.4V)→(Vs(typ.)-0.4V)
 Designed Guarantee.(Outgoing inspection is not done on all products.)

● Block Diagrams

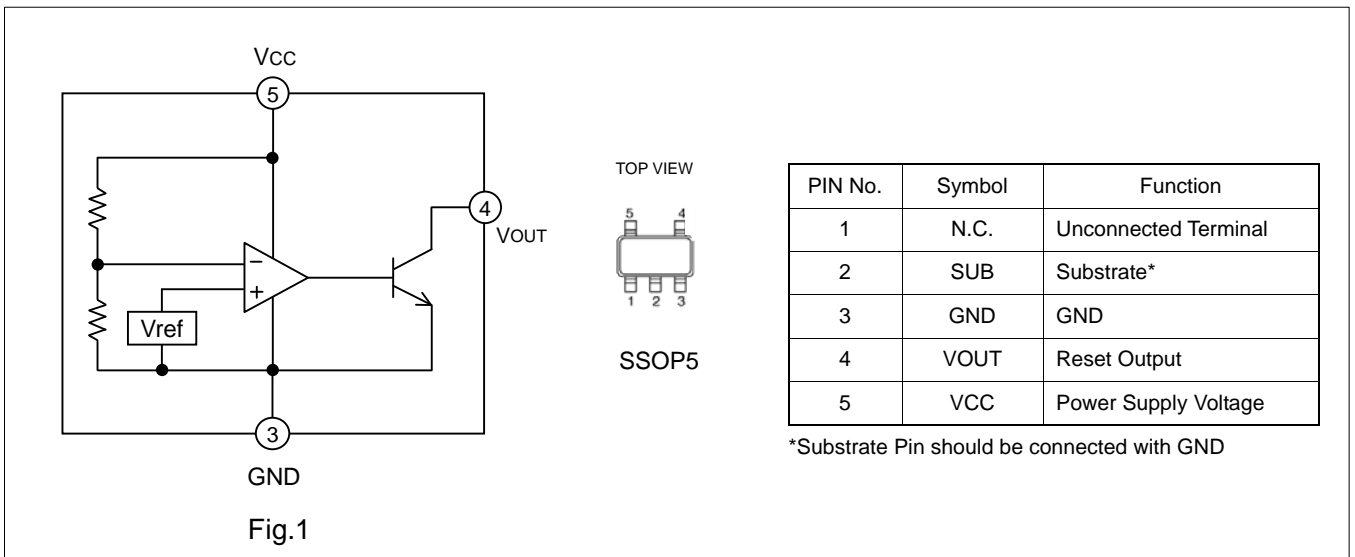

● Reference Data (Unless specified otherwise, Ta=25°C)

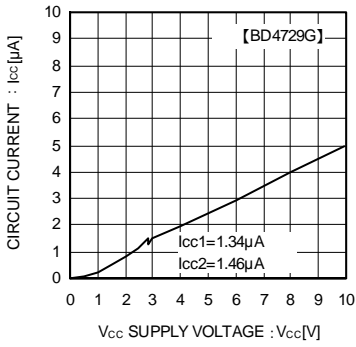

Fig.2 Circuit Current

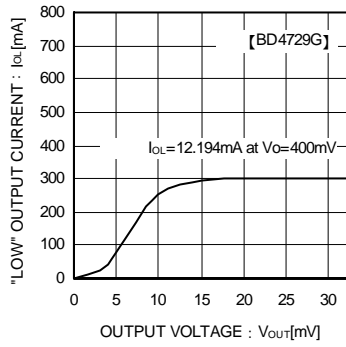

Fig.3 "Low" Output Current

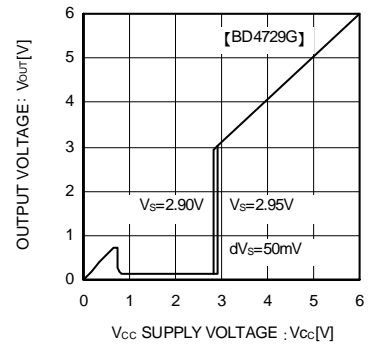

Fig.4 I/O Characteristics

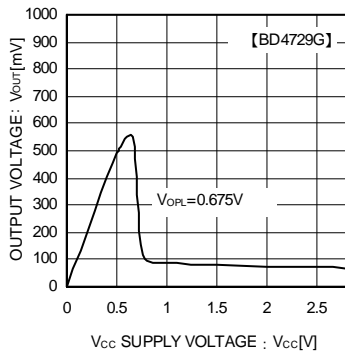

Fig.5 Operating Limit Voltage

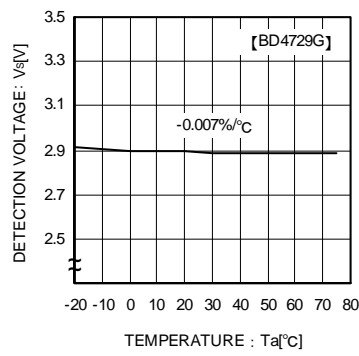

Fig.6 Detection Voltage

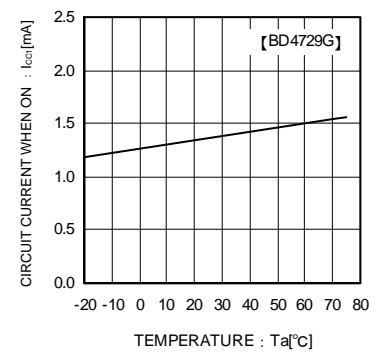

Fig.7 Circuit Current when ON

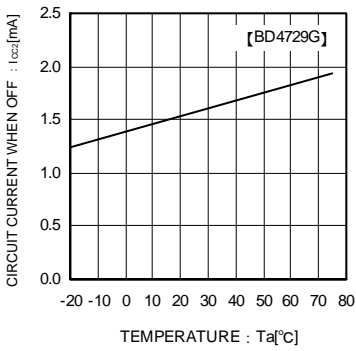

Fig.8 Circuit Current when OFF

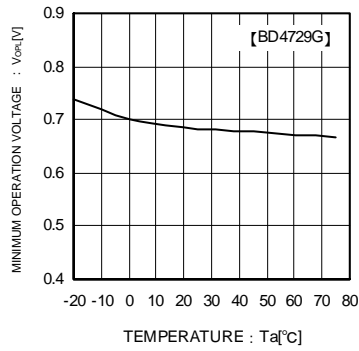

Fig.9 Operating Limit Voltage

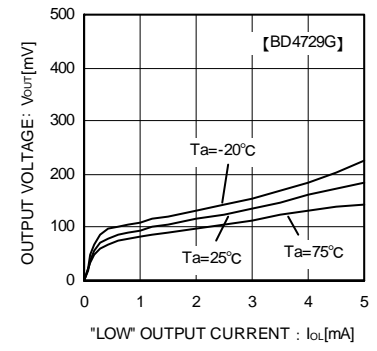

Fig.10 Output Saturation Voltage

● Explanation of Operation

BD47□□G series has the detection voltages and release voltages as threshold voltages and, as the voltages applied to the input reach their respective threshold voltages, the output switches from “High” to “Low” and from “Low” to “High”. The release voltage has a hysteresis that is the detection voltage +50mV (Typ.), preventing chattering in the output. When the input is greater than the release voltage, the output is in a “High” state. When the input is lowered from that state, the output switches to “Low” on the detection voltage. When the input is less than the detection voltage, the output is in a “Low” state. When the input is raised from that state, the output switches to “High” with the release voltage. Additionally, at least 0.85V is required for the circuit to operate fully. When the input falls below the operating limit voltage, the output becomes unsettled.

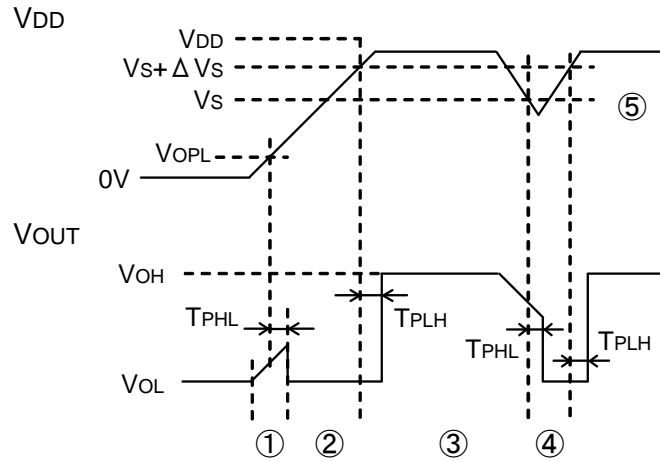

Fig.11 Timing Waveform

- ① When the power supply is turned on, the output is unsettled from after over the operating limit voltage (VOPL) until TPLH. Therefore it is possible that the reset signal is not outputted when the rise time of Vcc is faster than TPLH.
- ② When Vcc is greater than VOPL but less than the reset release voltage (VS + ΔVS), the output voltages will switch to Low.
- ③ If Vcc exceeds the reset release voltage (VS + ΔVS), then VOUT switches from L to H.
- ④ If Vcc drops below the detection voltage (VS) when the power supply is powered down or when there is a power supply fluctuation, VOUT switches to L (with a delay of TPLH).
- ⑤ The potential difference between the detection voltage and the release voltage is known as the hysteresis width (ΔVS). The system is designed such that the output does not flip-flop with power supply fluctuations within this hysteresis width, preventing malfunctions due to noise.

<Precautions>

Please be aware that when there is resistance on the power supply line, the detection voltage varies with voltage drops caused by the IC current consumption.

Please connect a capacitor between VCC and GND when the power supply line has high impedance.

● Circuit Applications

- 1) The following is an example of an application circuit using Reset IC for normal power supply detection. BD47□□G series requires a pull up resistor on the output terminal. The pull up resistor value should be decided. As the application with enough confirmation of power supply level and output current capability. When a capacitor has been inserted into the output terminal to delay the output time or to remove noise, the output will be slower during starting or stopping. Please be careful to select the appropriate pull up resistors, output current and capacitor when inserting a bypass capacitor between input and GND. Please be aware that if an extremely large capacitor is used, the response time will become excessively slow.

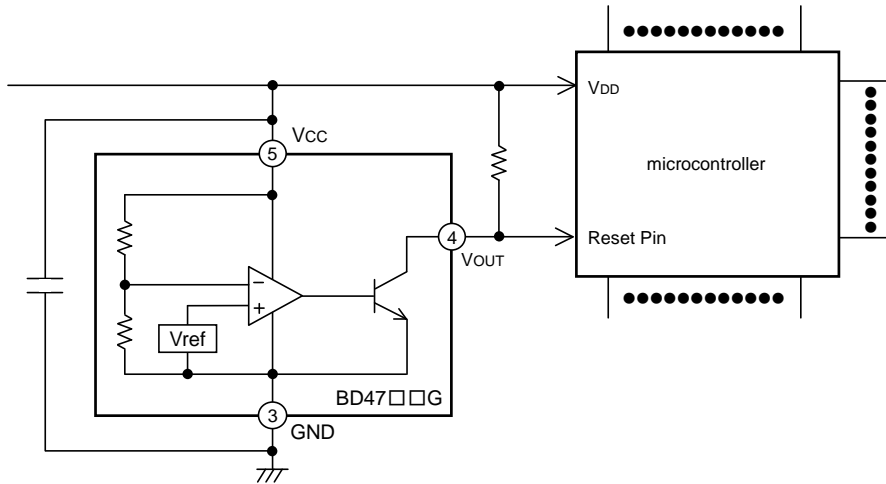

Fig.12

- 2) The following shows an example of adding delay time to a reset signal. It is possible to set the delay time using the capacitor CL and the resistor RL connected to the output terminal as shown below. At VCC start up, CL will be charged by RL. The CL and RL time constants and the threshold voltage of the Reset terminal determine the charge delay time. When VCC is decreased, CL is discharged through the Reset IC. The sum of the respective times plus the delay time of the IC itself becomes the reset signal delay time.

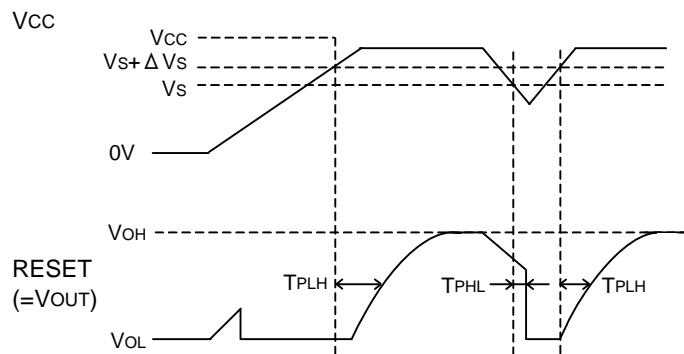
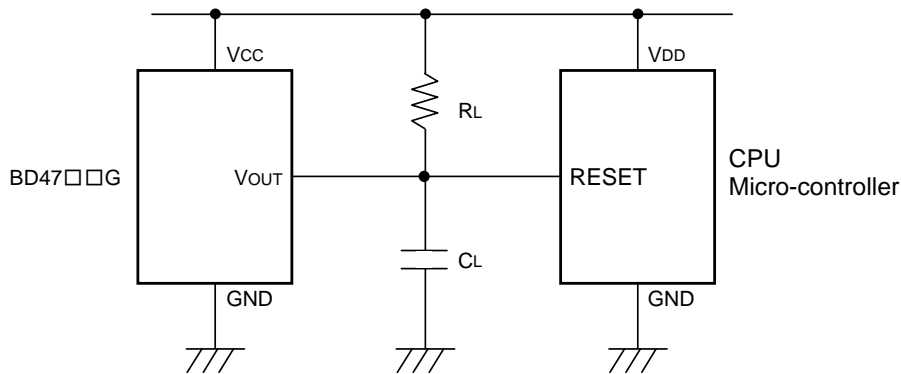
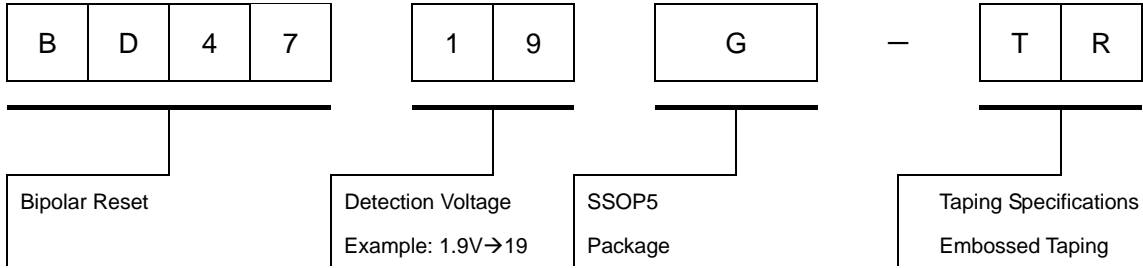

Fig.13

● Operation Notes

1. Absolute maximum range
Absolute Maximum Ratings are those values beyond which the life of a device may be destroyed. We cannot be defined the failure mode, such as short mode or open mode. Therefore a physical security countermeasure, like fuse, is to be given when a specific mode to be beyond absolute maximum ratings is considered.
2. GND potential
GND terminal should be a lowest voltage potential every state. Please make sure all pins, which are over ground even if, include transient feature.
3. Electromagnetic Field
Mal-function may happen when the device is used in the strong electromagnetic field.
4. Bypass Capacitor for Noise Rejection
Please put into the capacitor between VCC pin and GND, to reject noise. If extremely big capacitor is used, transient response might be late. Please confirm sufficiently for the point.
5. Short Circuit between Terminal and Soldering
Don't short-circuit between Output pin and VCC pin, Output pin and GND pin, or VCC pin and GND pin. When soldering the IC on circuit board, please be unusually cautious about the orientation and the position of the IC. When the orientation is mistaken the IC may be destroyed.
6. This IC has extremely high impedance terminals. Small leak current due to the uncleanness of PCB surface might cause unexpected operations. Application values in these conditions should be selected carefully. If the leakage is assumed between the VOUT terminal and the GND terminal, the pull-up resistor should be less than 1/10 of the assumed leak resistance.
7. External parameters
The recommended parameter range for RL is 2kΩ~1MΩ. There are many factors (board layout, etc) that can affect characteristics. Please verify and confirm using practical applications.
8. Power on reset operation
Please note that the power on reset output varies with the Vcc rise up time. Please verify the actual operation.
9. Precautions for board inspection
Connecting low-impedance capacitors to run inspections with the board may produce stress on the IC. Therefore, be certain to use proper discharge procedure before each process of the test operation.
To prevent electrostatic accumulation and discharge in the assembly process, thoroughly ground yourself and any equipment that could sustain ESD damage, and continue observing ESD-prevention procedures in all handling, transfer and storage operations. Before attempting to connect components to the test setup, make certain that the power supply is OFF. Likewise, be sure the power supply is OFF before removing any component connected to the test setup.
10. When the power supply, is turned on because of in certain cases, momentary Rash-current flow into the IC at the logic unsettled, the couple capacitance, GND pattern of width and leading line must be considered.

● Part Number Selection



SSOP5

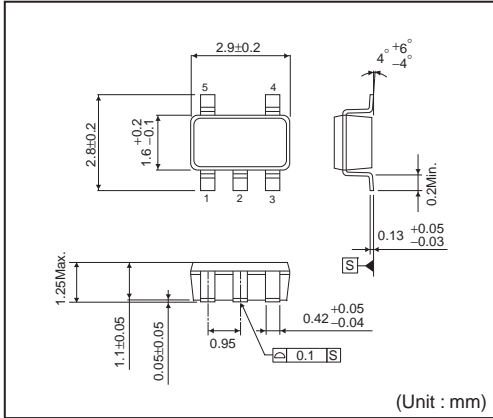

<Tape and Reel information>

Tape	Embossed carrier tape
Quantity	3000pcs
Direction of feed	TR (The direction is the 1pin of product is at the upper right when you hold reel on the left hand and you pull out the tape on the right hand)

* Order quantity needs to be multiple of the minimum quantity.

Notes

No copying or reproduction of this document, in part or in whole, is permitted without the consent of ROHM Co.,Ltd.

The content specified herein is subject to change for improvement without notice.

The content specified herein is for the purpose of introducing ROHM's products (hereinafter "Products"). If you wish to use any such Product, please be sure to refer to the specifications, which can be obtained from ROHM upon request.

Examples of application circuits, circuit constants and any other information contained herein illustrate the standard usage and operations of the Products. The peripheral conditions must be taken into account when designing circuits for mass production.

Great care was taken in ensuring the accuracy of the information specified in this document. However, should you incur any damage arising from any inaccuracy or misprint of such information, ROHM shall bear no responsibility for such damage.

The technical information specified herein is intended only to show the typical functions of and examples of application circuits for the Products. ROHM does not grant you, explicitly or implicitly, any license to use or exercise intellectual property or other rights held by ROHM and other parties. ROHM shall bear no responsibility whatsoever for any dispute arising from the use of such technical information.

The Products specified in this document are intended to be used with general-use electronic equipment or devices (such as audio visual equipment, office-automation equipment, communication devices, electronic appliances and amusement devices).

The Products specified in this document are not designed to be radiation tolerant.

While ROHM always makes efforts to enhance the quality and reliability of its Products, a Product may fail or malfunction for a variety of reasons.

Please be sure to implement in your equipment using the Products safety measures to guard against the possibility of physical injury, fire or any other damage caused in the event of the failure of any Product, such as derating, redundancy, fire control and fail-safe designs. ROHM shall bear no responsibility whatsoever for your use of any Product outside of the prescribed scope or not in accordance with the instruction manual.

The Products are not designed or manufactured to be used with any equipment, device or system which requires an extremely high level of reliability the failure or malfunction of which may result in a direct threat to human life or create a risk of human injury (such as a medical instrument, transportation equipment, aerospace machinery, nuclear-reactor controller, fuel-controller or other safety device). ROHM shall bear no responsibility in any way for use of any of the Products for the above special purposes. If a Product is intended to be used for any such special purpose, please contact a ROHM sales representative before purchasing.

If you intend to export or ship overseas any Product or technology specified herein that may be controlled under the Foreign Exchange and the Foreign Trade Law, you will be required to obtain a license or permit under the Law.



Thank you for your accessing to ROHM product informations.
More detail product informations and catalogs are available, please contact us.

ROHM Customer Support System

<http://www.rohm.com/contact/>