

LCD Panel EMI Reduction IC

Features

- FCC approved method of EMI attenuation.
- Provides up to 15dB of EMI suppression.
- Generates a low EMI spread spectrum clock of the input frequency.
- Input frequency range: 30MHz to 110MHz.
- Optimized for 32.5MHz, 54MHz, 65MHz and 108MHz pixel clock frequencies.
- Internal loop filter minimizes external components and board space.
- Eight selectable high spread ranges up to $\pm 1.9\%$.
- SSON# control pin for spread spectrum enable and disable options.
- Low cycle-to-cycle jitter.
- $3.3V \pm 0.3V$ operating range.
- Low power CMOS design.
- Supports most mobile graphic accelerator and LCD timing controller specifications.
- Available in 8-pin SOIC and TSSOP Packages.

interference (EMI) at the clock source, allowing system wide reduction of EMI of down stream clock and data dependent signals. The P2042A allows significant system cost savings by reducing the number of circuit board layers ferrite beads, shielding and other passive components that are traditionally required to pass EMI regulations.

The P2042A uses the most efficient and optimized modulation profile approved by the FCC and is implemented in a proprietary all digital method.

The P2042A modulates the output of a single PLL in order to "spread" the bandwidth of a synthesized clock, and more importantly, decreases the peak amplitudes of its harmonics. This results in significantly lower system EMI compared to the typical narrow band signal produced by oscillators and most frequency generators. Lowering EMI by increasing a signal's bandwidth is called 'spread spectrum clock generation'.

Product Description

The P2042A is a versatile spread spectrum frequency modulator designed specifically for digital flat panel applications. The P2042A reduces electromagnetic

Applications

The P2042A is targeted towards digital flat panel applications for notebook PCs, palm-size PCs, office automation equipments and LCD monitors.

Block Diagram

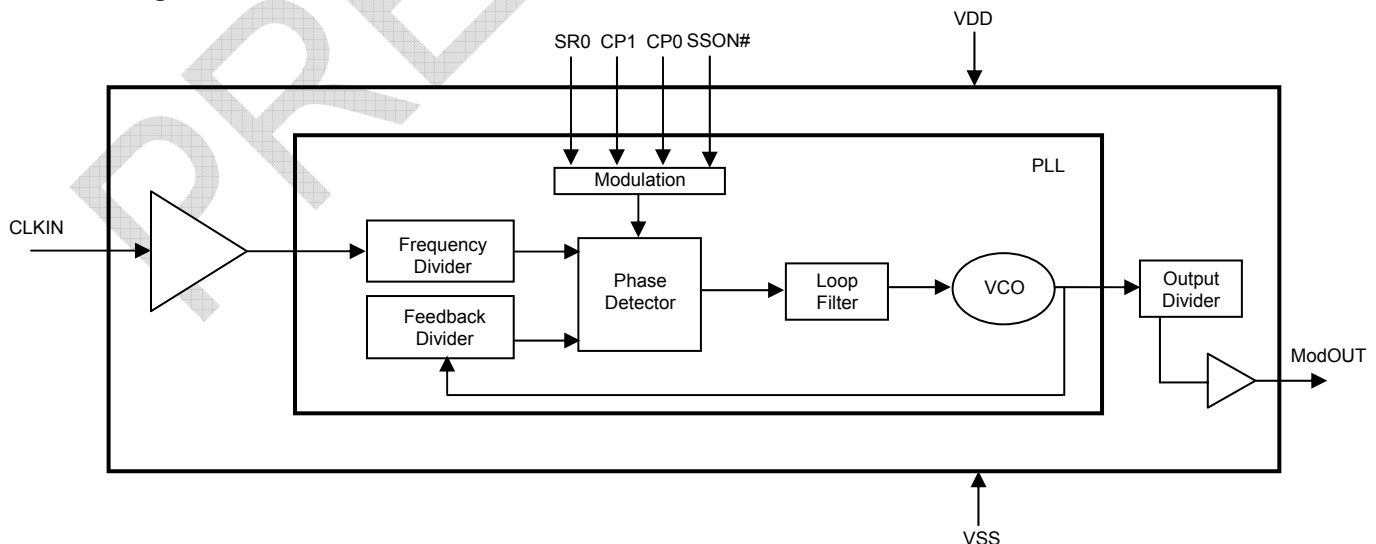

rev 1.4

Pin Configuration

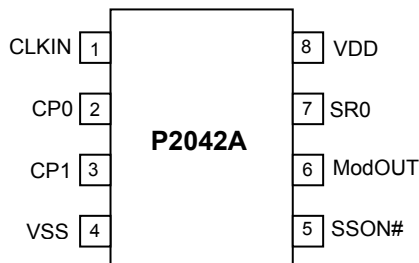

Pin Description

Pin#	Pin Name	Type	Description
1	CLKIN	I	External reference frequency input. Connect to externally generated reference signal.
2	CP0	I	Digital logic input used to select charge pump current. This pin has an internal pull-up resistor. Refer Modulation Selection Table.
3	CP1	I	Digital logic input used to select charge pump current. This pin has an internal pull-up resistor. Refer Modulation Selection Table.
4	VSS	P	Ground to entire chip. Connect to system ground.
5	SSON#	I	Digital logic input used to enable Spread Spectrum function (Active LOW). Spread Spectrum function enabled when LOW, disabled when HIGH. This pin has an internal pull-low resistor.
6	ModOUT	O	Spread spectrum clock output.
7	SR0	I	Digital logic input used to select Spreading Range. This pin has an internal pull-up resistor.
8	VDD	P	Power supply for the entire chip

Modulation Selection

CP0	CP1	SR0	Spreading Range (±%)					Modulation Rate (KHz)
			32.5MHz	54MHz	65MHz	81MHz	108MHz	
0	0	0	0.56	1.05	1.00	0.98	0.80	(FIN /40) * 62.49 KHz
0	0	1	1.94	1.68	1.56	1.48	1.22	
0	1	0	1.36	1.05	1.00	0.92	0.67	
0	1	1	1.92	1.68	1.56	1.48	1.06	
1	0	0	1.24	0.81	0.66	0.40	0.27	
1	0	1	1.91	1.29	1.02	0.74	0.43	
1	1	0	0.91	0.45	0.34	0.05	0.15	
1	1	1	1.47	0.71	0.54	0.36	0.21	

rev 1.4

Spread Spectrum Selection

The *Modulation Selection Table* defines the possible spread spectrum options. The optimal setting should minimize system EMI to the fullest without affecting system performance. The spreading is described as a percentage deviation of the center frequency. (Note: The center frequency is the frequency of the external reference input on CLKIN, pin1).

For example, P2042A is designed for high-resolution, flat panel applications and is able to support an XGA (1024 x 768) flat panel operating at 65MHz (FIN) clock speed. A spreading selection of CP0=0, CP1=1 and SR0=0 provides a percentage deviation of $\pm 1.00\%$ from F_{IN} . This results in the frequency on ModOUT being swept from 65.65 to 64.35MHz at a modulation rate of 101.54KHz. Refer *Modulation Selection Table*. The example in the following illustration is a common EMI reduction method for a notebook LCD panel and has already been implemented by most of the leading OEM and mobile graphic accelerator manufacturers.

Application Schematic for Mobile LCD Graphics Controllers

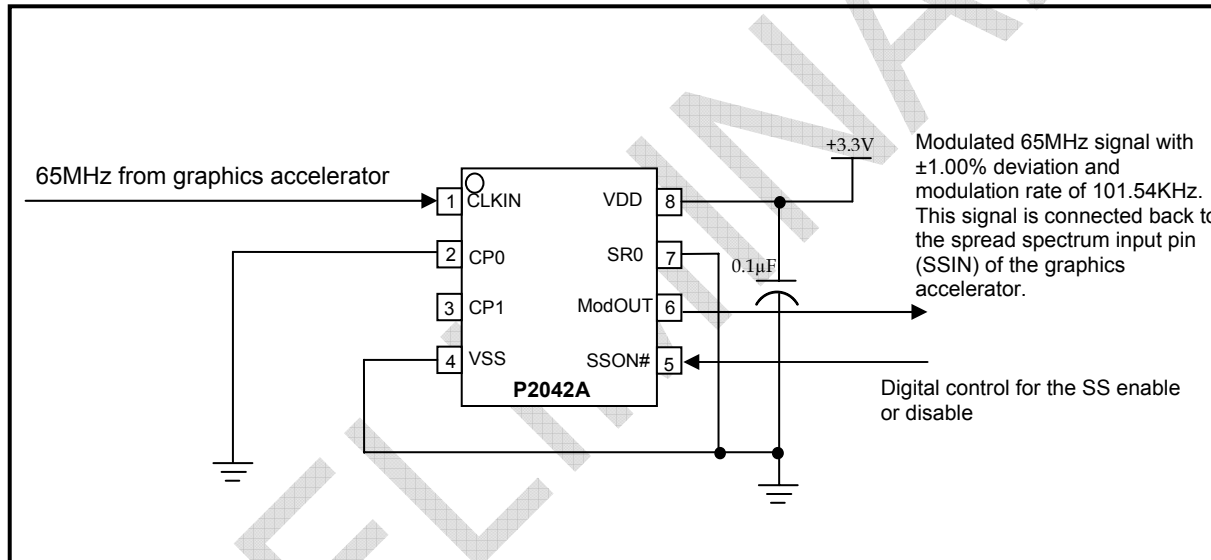

rev 1.4

Absolute Maximum Ratings

Symbol	Parameter	Rating	Unit
VDD, VIN	Voltage on any pin with respect to Ground	-0.5 to +4.6	V
T _{STG}	Storage temperature	-65 to +125	°C
T _A	Operating temperature	-40 to +85	°C
T _s	Max. Soldering Temperature (10 sec)	260	°C
T _J	Junction Temperature	150	°C
T _{DV}	Static Discharge Voltage (As per JEDEC STD22- A114-B)	2	KV

Note: These are stress ratings only and are not implied for functional use. Exposure to absolute maximum ratings for prolonged periods of time may affect device reliability.

DC Electrical Characteristics

Symbol	Parameter	Min	Typ	Max	Unit
V _{IL}	Input low voltage	VSS - 0.3	–	0.8	V
V _{IH}	Input high voltage	2.0	–	VDD + 0.3	V
I _{IL}	Input low current (pull-up resistor on inputs CP0, CP1 and SR0)	–	–	-35	µA
I _{IH}	Input high current (pull-down resistor on input SSON#)	–	–	35	µA
V _{OL}	Output low voltage (V _{DD} = 3.3 V, I _{OL} = 20 mA)	–	–	0.4	V
V _{OH}	Output high voltage (V _{DD} = 3.3 V, I _{OL} = 20 mA)	2.5	–	–	V
I _{DD}	Static supply current standby mode	–	0.6	–	mA
I _{CC}	Dynamic supply current (3.3V and 10pF loading)	9	16	22	mA
V _{DD}	Operating voltage	3.0	3.3	3.6	V
t _{ON}	Power-up time (first locked cycle after power up)	–	0.18	–	mS
Z _{OUT}	Clock output impedance	–	50	–	Ω

AC Electrical Characteristics

Symbol	Parameter	Min	Typ	Max	Unit
f _{IN}	Input frequency	30	65	110	MHz
f _{OUT}	Output frequency	30	65	110	MHz
t _{LH} *	Output rise time (measured at 0.8V to 2.0V)	0.7	0.9	1.1	nS
t _{HL} *	Output fall time (measured at 2.0V to 0.8V)	0.6	0.8	1.0	nS
t _{JC}	Jitter (cycle to cycle)	-	-	360	pS
t _D	Output duty cycle	45	50	55	%

*t_{LH} and t_{HL} are measured into a capacitive load of 15pF

Package Information

8-lead SOIC Package

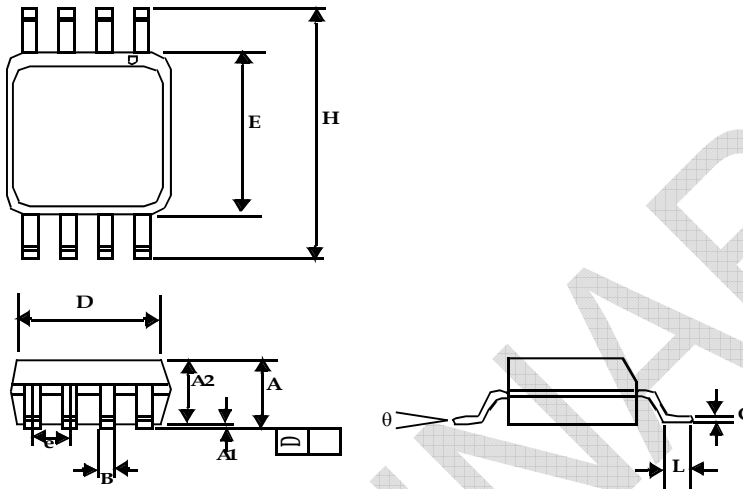

Symbol	Dimensions			
	Inches		Millimeters	
	Min	Max	Min	Max
A1	0.004	0.010	0.10	0.25
A	0.053	0.069	1.35	1.75
A2	0.049	0.059	1.25	1.50
B	0.012	0.020	0.31	0.51
C	0.007	0.010	0.18	0.25
D	0.193 BSC		4.90 BSC	
E	0.154 BSC		3.91 BSC	
e	0.050 BSC		1.27 BSC	
H	0.236 BSC		6.00 BSC	
L	0.016	0.050	0.41	1.27
θ	0°	8°	0°	8°

8-lead TSSOP

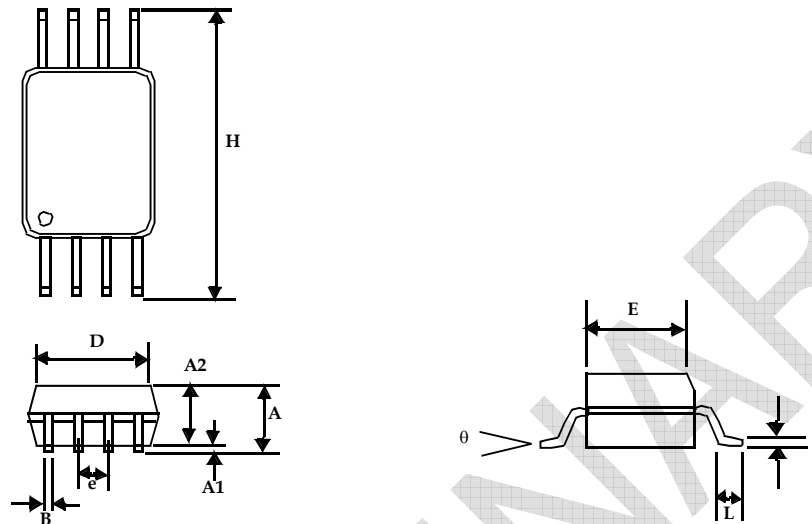

Symbol	Dimensions			
	Inches		Millimeters	
	Min	Max	Min	Max
A		0.043		1.10
A1	0.002	0.006	0.05	0.15
A2	0.033	0.037	0.85	0.95
B	0.008	0.012	0.19	0.30
c	0.004	0.008	0.09	0.20
D	0.114	0.122	2.90	3.10
E	0.169	0.177	4.30	4.50
e	0.026 BSC		0.65 BSC	
H	0.252 BSC		6.40 BSC	
L	0.020	0.028	0.50	0.70
theta	0°	8°	0°	8°

Ordering Information

Part Number	Marking	Package Type	Temperature
P2042AF-08ST	P2042AF	8-Pin SOIC, TUBE, Pb Free	Commercial
P2042AF-08SR	P2042AF	8-Pin SOIC, TAPE & REEL, Pb Free	Commercial
P2042AF-08TT	P2042AF	8-Pin TSSOP, TUBE, Pb Free	Commercial
P2042AF-08TR	P2042AF	8-Pin TSSOP, TAPE & REEL, Pb Free	Commercial
P2042AG-08ST	P2042AG	8-Pin SOIC, TUBE, Green	Commercial
P2042AG-08SR	P2042AG	8-Pin SOIC, TAPE & REEL, Green	Commercial
P2042AG-08TT	P2042AG	8-Pin TSSOP, TUBE, Green	Commercial
P2042AG-08TR	P2042AG	8-Pin TSSOP, TAPE & REEL, Green	Commercial
I2042AF-08ST	I2042AF	8-Pin SOIC, TUBE, Pb Free	Industrial
I2042AF-08SR	I2042AF	8-Pin SOIC, TAPE & REEL, Pb Free	Industrial
I2042AF-08TT	I2042AF	8-Pin TSSOP, TUBE, Pb Free	Industrial
I2042AF-08TR	I2042AF	8-Pin TSSOP, TAPE & REEL, Pb Free	Industrial
I2042AG-08ST	I2042AG	8-Pin SOIC, TUBE, Green	Industrial
I2042AG-08SR	I2042AG	8-Pin SOIC, TAPE & REEL, Green	Industrial
I2042AG-08TT	I2042AG	8-Pin TSSOP, TUBE, Green	Industrial
I2042AG-08TR	I2042AG	8-Pin TSSOP, TAPE & REEL, Green	Industrial

Device Ordering Information

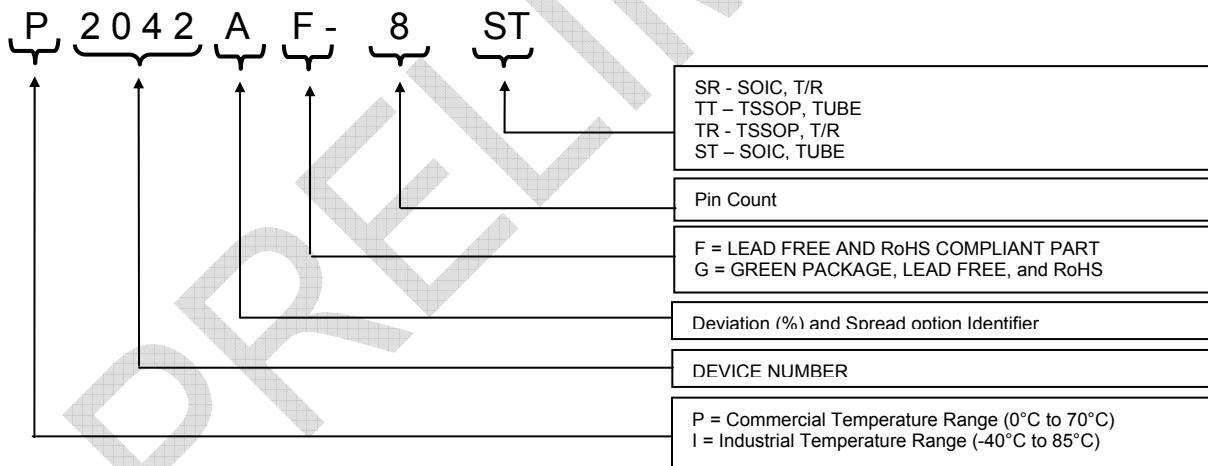

rev 1.4

Licensed under U.S Patent Nos 5,488,627 and 5,631,921



Giving you the edge

PulseCore Semiconductor Corporation
1715 S. Bascom Ave Suite 200
Campbell, CA 95008
Tel: 408-879-9077
Fax: 408-879-9018
www.pulsecoresemi.com

Copyright © PulseCore Semiconductor
All Rights Reserved
Preliminary Information
Part Number: P2042A
Document Version: v1.4

Note: This product utilizes US Patent # 6,646,463 Impedance Emulator Patent issued to PulseCore Semiconductor, dated 11-11-2003

© Copyright 2006 PulseCore Semiconductor Corporation. All rights reserved. Our logo and name are trademarks or registered trademarks of PulseCore Semiconductor. All other brand and product names may be the trademarks of their respective companies. PulseCore reserves the right to make changes to this document and its products at any time without notice. PulseCore assumes no responsibility for any errors that may appear in this document. The data contained herein represents PulseCore's best data and/or estimates at the time of issuance. PulseCore reserves the right to change or correct this data at any time, without notice. If the product described herein is under development, significant changes to these specifications are possible. The information in this product data sheet is intended to be general descriptive information for potential customers and users, and is not intended to operate as, or provide, any guarantee or warranty to any user or customer. PulseCore does not assume any responsibility or liability arising out of the application or use of any product described herein, and disclaims any express or implied warranties related to the sale and/or use of PulseCore products including liability or warranties related to fitness for a particular purpose, merchantability, or infringement of any intellectual property rights, except as express agreed to in PulseCore's Terms and Conditions of Sale (which are available from PulseCore). All sales of PulseCore products are made exclusively according to PulseCore's Terms and Conditions of Sale. The purchase of products from PulseCore does not convey a license under any patent rights, copyrights; mask works rights, trademarks, or any other intellectual property rights of PulseCore or third parties. PulseCore does not authorize its products for use as critical components in life-supporting systems where a malfunction or failure may reasonably be expected to result in significant injury to the user, and the inclusion of PulseCore products in such life-supporting systems implies that the manufacturer assumes all risk of such use and agrees to indemnify PulseCore against all claims arising from such use.