

## 100-041

**Tapered Tubular Metal Braid Nickel/Copper, Silver/Copper or Tin/Copper for Series 72 & 74 Tubing and Series 75 Conduit**

**100-041-06 N 5 A**

Product Series ————

Dash No. (Table I or II) ————

Material ————

N = Nickel/Copper  
S = Silver/Copper  
T = Tin/Copper

A = 36 AWG (Omit for 34 AWG)  
Length in 1 inch increments

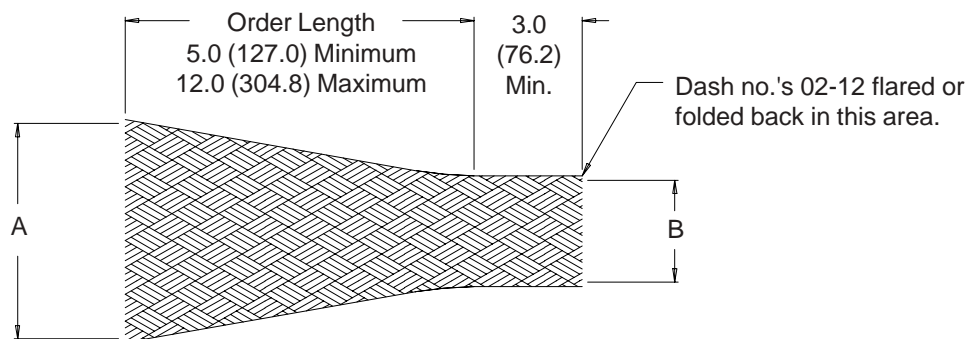

TABLE I				
Dash No.	A		B	
	+ .10 - .00	(2.5) (0.0)	+ .10 - .00	(2.5) (0.0)
01	.30	(7.6)	.15	(3.8)
02	.45	(11.4)	.30	(7.6)
03	.60	(15.2)	.30	(7.6)
04	.75	(19.1)	.30	(7.6)
05	.75	(19.1)	.50	(12.7)
06	1.05	(26.7)	.50	(12.7)
07	1.05	(26.7)	.75	(19.1)
08	1.20	(30.5)	.75	(19.1)
09	1.20	(30.5)	1.00	(25.4)
10	1.50	(38.1)	.75	(19.1)
11	1.50	(38.1)	1.00	(25.4)
12	1.50	(38.1)	1.20	(30.5)
13	.88	(22.4)	.50	(12.7)
14	1.38	(35.1)	.75	(19.1)

Consult with the factory for custom tapered braid configurations.

Metric dimensions (mm) are indicated in parentheses.